



RFH6xx

RFID read/write device (HF) with internal short range antenna

RFH630-1102101S05

SICK
Sensor Intelligence.



Intended use

The RFH630-1102101S05 read/write device is an intelligent SICK-4Dpro sensor from the RFH6xx product family. The special device is used for the automatic, stationary identification of transponders and their management. The special device enables a process reliable reading/writing of the die. The die acts as a HF transponder (ISO15693) with an integrated coil and IC (Integrated Circuit). The transponders are located on moving or stationary objects.

As a compact device, the RFH630-1102101S05 has an integrated antenna. It processes all standard ISO/IEC-15693-compatible transponders on carrier frequency 13.56 MHz. Thanks to its intelligent process logic, it can be used either as a stand-alone solution or as part of a group in a network.

The RFH630-1102101S05 read/write device sends the read results to a higher-level computer for further processing via its host interface. Or it receives commands for transponder management (write, read, etc.) via this interface.

Intended use also includes compliance with all information in this Quickstart.

For simplicity in this document, the RFH630-1102101S05 read/write device is referred to as the "device".

About this document

The purpose of this Quickstart is to allow you to commission the device quickly and easily, and to achieve initial read results with transponders.

The Quickstart describes the commissioning process for an application with **one** device in ambient temperature range 0 °C to +50 °C, based on its default setting. The optional CDB620-001 connection module is used for the industrial-standard signal distribution of the device.

Supplementary and other relevant documents

The *RFH630 technical information* contains more detailed information pertaining to the mechanical and electrical installation for the (part no. 8014957, English version, PDF).

The technical information as well as additional information, such as application examples and downloads of associated documents and associated software, can be found on the SICK product page on the Internet at www.sick.com/RFH6xx.

→ See also "Sources for additional information" on page 5.

Information about configuration can be found in the online help function of the SOPAS ET configuration software.

Operating the device in a fieldbus with line topology

The optional incorporation of the device in fieldbuses is described in the relevant *Operating instructions for the CDF600-2 PROFIBUS DP, CDF600-2 PROFINET, or CDF600 EtherCAT® fieldbus module*. → See "Sources for additional information" on page 5.

Safety information

- This chapter concerns the safety of commissioning personnel as well as operators of the system in which the device is integrated.
- Read this Quickstart carefully before commissioning the device in order to familiarize yourself with the device and its functions. The Quickstart is considered to be a part of the device and must be kept in an accessible location in the immediate vicinity of the device at all times!
- The following requirements must be met if the IP 67 enclosure rating is to be maintained during

operation (otherwise, the device will no longer meet the conditions for any specified enclosure rating):

- The side cover of the microSD card slot must be screwed tight to the device.
- The SICK cables plugged into the M12 connections must be screwed tight.
- Any electrical connections that are not being used must be fitted with protective caps or plugs that are screwed tight (as in the delivery condition).
- Only operate the device without the cover for a short period while inserting or removing the memory card. During this time, protect the device against moisture and dust.
- Opening the screws of the device housing will invalidate any warranty claims against SICK AG. For further warranty provisions, see the General Terms and Conditions of SICK AG, e.g., on the delivery note of the device
- Data integrity:
SICK AG uses standardized data interfaces, such as standard IP technology, in its products. The emphasis here is on the availability of products and their features. SICK AG always assumes that the integrity and confidentiality of the data and rights affected by the use of these products will be ensured by the customer. In all cases, appropriate security measures, such as network separation, firewalls, virus protection, and patch management, must be taken by the customer on the basis of the situation in question.

Commissioning and configuration

Scope of delivery

- RFH630-1102101S05 special device. Electrical connections fitted with protective caps or plugs if necessary. Without connecting cables and brackets.
- Printed Quickstart: English (part no. 8023443), German (part no. 8023442).

Step 1: Mounting and alignment

Equipment required

- At least 2 x M6 screws or 2 x M4 screws for mounting the device on a mounting device (bracket) provided by the customer. Screw length is dependent on the mounting base (wall thickness of the bracket). When using an optional SICK bracket, the screws for mounting the device on the bracket are included in the scope of delivery of the bracket.

Mounting requirements

- The permissible ambient conditions for operating the device must be observed, e.g., ambient temperature, ground potential. → See "Technical data (excerpt)" on page 4 and "Step 2: Electrical installation" on page 2.
- The device must be mounted using all 4 M6 threaded mounting holes (minimum 2) or 2 through holes (both) provided. → See "Device layout" on page 5.
- Stable mounting device with sufficient load-bearing capacity and suitable dimensions for the device. Weight max. 760 g (not including cables). → See "Device layout" on page 5.
- The device should be as free from shock and vibration as possible when mounted.
- To prevent mutual interference with a neighboring device, ensure that there is sufficient distance between the two devices which are being operated simultaneously.

Mounting the device

1. Select a suitable mounting location for the device. The mounting location and position depend on the antenna fields of the device and the transponders used.
2. Optional: Attach mounting kit part no. 2048551 (optional accessory) to the device (see *RFH630 technical information, "Mounting" chapter*). Otherwise, mount the device on the bracket provided by the customer using at least 2 M6 screws. Screw in the M6 screws to max. 6.5 mm into the threaded mounting holes (→ see "Device layout" on page 5).
3. Align the surface of the integrated antenna on the device (front face) and where applicable the external antenna of the transponder to the object. Avoid any large metal surfaces positioned to the front as far as possible.
4. Ensure that no electrically conductive objects, such as metal objects, are positioned between the device/external antenna and the transponder during the read/write process. This would attenuate the generated HF field and thereby reduce the scanning range of the device.

Scanning range of the read/write field on the device

The maximum scanning range for communication between the device and transponder depends on various factors. Primarily, the dimensions of the transponder's antenna positively affects the scanning range. An additional factor for the scanning range is the quality of the transponder, for example, the

antenna gain, the integrated transponder IC, and its associated sensitivity.

Important!

A successful reading/writing can only be guaranteed if the transponder is orientated plan parallel to the antenna and in the middle of the read/write device.



Fig. 1: Optimal alignment of customer specific transponder to the device

CDB620-001 connection module

- Mount the CDB620-001 connection module in the vicinity of the device. If you are using the serial data interfaces (RS-232), we recommend a max. distance of 3 m. Mount the CDB620-001 in such a way that the device remains accessible at all times. See also [CDB620-001 connection module operating instructions](#) (part no. 8012119). → See “Sources for additional information” on page 5.

Step 2: Electrical installation

- **The electrical installation must only be performed by electrically qualified persons.**
- **Standard safety requirements must be met when working in electrical systems.**
- Electrical connections between the device and other devices may only be created or disconnected when there is no power to the system. Otherwise, the devices may be damaged.
- When using connecting or extension cables with an open end, make sure that bare wire ends are not touching (risk of short-circuit when the supply voltage is switched on). Wires must be appropriately insulated from each other.
- Wire cross-sections in the supply cable from the customer's power system must be designed in accordance with the applicable standards. 0.8 A protection at the start of the feeding supply circuit when the device is operated without a connection module using a SICK cable.

- The power supply via a power supply unit must be capable of buffering a brief power failure of 20 ms.
- All circuits connected to the device must be designed as ES1 circuits. The power supply or power supply unit must satisfy ES1 requirements in accordance with the currently applicable EN 62368-1. (ES 1 = electrical source class 1).

NOTE

Risk of damage to the device due to possible short-circuit!

The supply voltage input in the device is designed with internal circuit protection to provide reverse polarity protection. The internal functional earth, which also corresponds to the negative pole of the device has a direct connection to the metal housing of the device due to reasons relating to high frequency.

If the supply voltage has the incorrect polarity, this will not cause any damage provided that the device is not connected (by

- either other cables or
- its housing)

to other peripheral devices that use the same grounding point.

⚠ WARNING

Risk of injury and damage caused by electrical current!

The device is designed to be operated in a system with professional grounding of all connected devices and mounting surfaces to the same ground potential. As a result of equipotential bonding currents between the device and other grounded devices in the system, faulty grounding of the device can have the following consequences:

- Metal housings are vulnerable to dangerous currents
- Malfunction and destruction of devices
- Damage to the cable shields caused by heating, resulting in cable fires.
- Ensure that the ground potential is the same at all grounding points. See the “Electrical installation” chapter in the [RFH630 technical information](#) for measures to eliminate hazards.
- If the cable insulation is damaged, disconnect the power supply immediately and have the damage repaired.

1. Connect the communication interface (e.g., Ethernet) of the device directly to the PC.

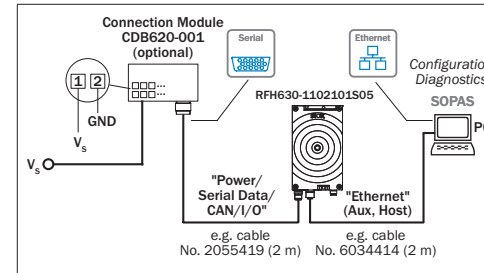

Fig. 2: Electrical connection block diagram of the device for commissioning in the default configuration

2. If an external antenna is being used (e.g., RFA332-2032, part no. 1054399), connect it to the antenna connection on the device.

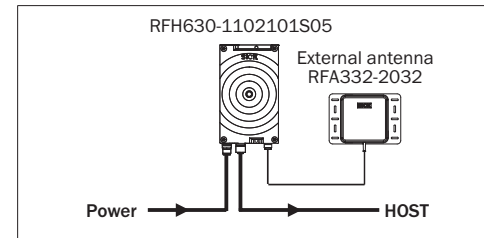

Fig. 3: Device with RFA332-2032 external antenna

3. If necessary, connect a read pulse sensor, such as a photoelectric sensor, to the “IN 1” switching input of the CDB620-001.
4. Supply power to the device. After successful initialization, the “Ready” LED illuminates green.

Step 3: Configuration with PC

The SOPAS ET configuration software is used by default to adjust the device parameters to the application and to the diagnostics in case of error.

a. Installing and starting the SOPAS ET configuration software

1. Download and install the software from the relevant SICK product page on the Internet at www.sick.com/SOPAS_ET:
 - Latest version of the configuration software
 - Current device description file (*.sdd) for the device.
2. For the configuration software, select the “Complete” option as selected by the installation wizard. Administrator rights may be required on the PC to install the software.

3. Start the “SOPAS ET” program option after completing the installation. Path: Start > Programs > SICK > SOPAS ET Engineering Tool > SOPAS.
4. Establish a connection between SOPAS ET and the device via the automatically opened wizard. To do so, select the device under the devices available depending on the connected communication interface, e.g., Ethernet.
5. The following IP address is configured by default on the RFH630-1102101S05:

IP-Address	192 . 168 . 0 . 1
Subnet-Mask	255 . 255 . 255 . 0

Fig. 4: Default IP address

6. SOPAS ET establishes communication with the device and loads the associated device description file for the device. The QUICKSTART tab opens.

b. Identifying a transponder in Quickstart mode

1. Bring one or more standards-compliant HF transponders into the working area of the internal antenna or, where applicable, the external antenna of the device.
2. Click the “Start” button in the QUICKSTART tab in SOPAS ET. SOPAS ET generates read pulses continuously and lists the identified transponders one after the other in the QUICKSTART window.

Quickstart					
Device Type: RFH620-1001201			Device ID: 1		
Nr.	UID	Manufacturer	IC	RSSI	
1	e0-07-80-36-51-e5-36-20	Texas Instruments	Tag-it HF-I plus	5	
2	e0-07-80-36-51-e4-83-25	Texas Instruments	Tag-it HF-I plus	5	
3	e0-08-01-8c-38-46-93-b7	Fujitsu	MB99R118	2	
4	e0-04-01-00-31-aa-9c-f4	KSP Semiconductors	Tricode S11	6	
5	e0-05-a1-20-00-04-78-ab	Infineon	SRF55W01P	6	
6	e0-05-a1-20-00-04-bc-ab	Infineon	SRF55W01P	2	

Not all tags displayed

Don't show this dialog on adding device

Fig. 5: SOPAS ET: Display of six identified transponders in the QUICKSTART window

Important!

The automatic triggering in Quickstart mode is intended for initial commissioning and not for permanent use when operating the device under real conditions.

c. Accessing the data on a transponder

1. In order to access the memory area of a transponder, click the STOP button in QUICKSTART.
2. Highlight the desired transponder (click it with the mouse).
3. Click the TRANSPONDER ACCESS button. The TRANSPONDER USER DATA tab displays the content of the selected transponder.

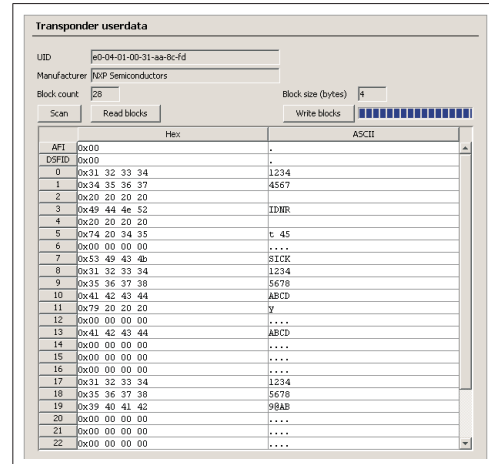

Fig. 6: SOPAS ET: TRANSPONDER USER DATA display window

Important!

The UID (Unique Identifier) of the transponder cannot be changed.

d. Continuing the configuration

1. Under SOPAS ET in the left-hand navigation tree, edit the required tabs for the application using the additional entries under PARAMETERS. These include transponder processing, object trigger control (e.g., via "Sensor 1" switching input), data processing and output, data output interface(s), and the function of the switching inputs and outputs.
2. Test and, if necessary, modify the settings made when operating the system under real conditions.

e. Completing the configuration

- Permanently save the entire configuration once it has been successfully tested:
Parameter set in the device: Click the button.
Configuration file on the PC: Click the button.

Device description

Device layout

➔ See "Device layout" on page 5.

Status indicators

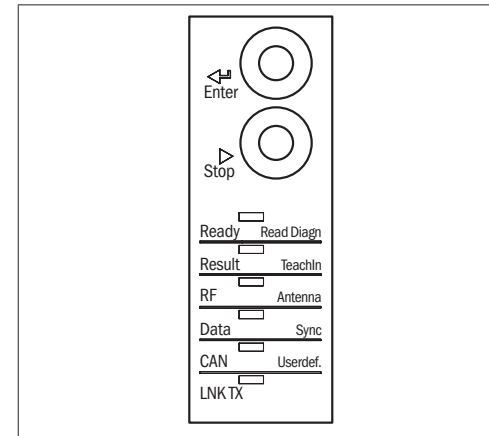

Fig. 7: Optical status indicators

Status indicators on the first display level

Display	LED	Color	Status
Ready	Lights up	Green	Lights up constantly after switching on and completion of successful self-test (device ready)
	Off	-	Goes out when downloading or uploading configuration data from and to the device
	Flashing	Green	PROFINET operation (single port): Flashes cyclically red (long) and green (short) alternately.
	Flashing	Red	Trying to establish a connection to a PLC (controller) or loss of connection during operation
Result	Lights up	Green	Successful read process (good read, 100 ms)
	Lights up	Green	HF field is switched on
RF	Lights up	Green	HF field is switched on

Display	LED	Color	Status
Data	Flashing	Yellow	Data transmission via host interface
CAN	Lights up	Green	CAN interface activated
	Flashing	Green	Data traffic via CAN interface
LNK TX	Flashing	Green	Data traffic via Ethernet interface
	Lights up	Yellow	Physical Ethernet connection

Tab. 1: Status indicators

Overview of interfaces and connection options

➔ See "Overview of interfaces and connection options" on page 3.

Overview of pin assignments

➔ See "Overview of pin assignments" on page 6.

MicroSD memory card (optional accessory)

Function

The device saves its configured parameter values as a parameter set in its internal permanent memory on request. An optional plug-in memory card can be used for additional parameter cloning on an external device. If the card is available, the device also saves the internal parameter set on this. To start cloning, save the parameter set in the device using the SOPAS ET option "Save parameter permanently". It is used, among other things, to conveniently transfer the parameter set to an exchange unit of the same type in the event of an error.

As an alternative to the memory card, you can use the optional CMC600 parameter storage module, which can be used in the optional connection module, e.g., CDB620-001 or CDM420-0001.

If both the memory card and the parameter storage module are available, the device adopts the parameter set from the CMC600 parameter storage module on restarting.

The first time a parameter set is stored, we recommend that an empty memory card is used (if necessary, check and delete the contents of the card on the PC using a card reader).

The memory card is not included with delivery.

Only use types approved by SICK to ensure reliable function of the memory card. See SICK product page

on the Internet at www.sick.com/RFH6xx.

The memory card has no write protection that can be activated.

Inserting the memory card

- To avoid damaging the memory card, make sure there is no power to the device when you insert or remove it.

The card slot can be accessed on the device behind the aluminum cover. ➔ See ⑩, "Device layout" on page 5.

Maintaining the IP 67 enclosure rating: ➔ See "Safety information" on page 1.

1. Turn off the supply voltage to the device.
2. To remove the cover, unscrew both Allen screws (A/F 2).
3. Making sure it is in the correct position (with the contacts pointing to the front and down – see the symbol on the device), insert the memory card into the card slot until it locks into place.
4. Screw the aluminum cover back on.
5. Turn on the supply voltage to the device.

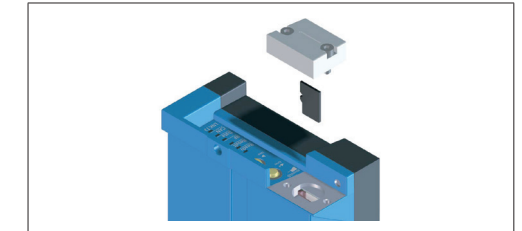

Fig. 8: Inserting the memory card

6. Once it is switched on, the device automatically detects the presence of a memory card and, depending on the card's content, behaves as follows:

- If the card is empty or if it contains a parameter set that cannot be interpreted by the device, the device saves its currently valid internal parameter set to the card and starts with this parameter set.
- If the card contains a parameter set that can be interpreted by the device, the device permanently overwrites the currently valid internal parameter set with this external parameter set. The goal is for the internal parameter set and the parameter set saved externally to always be identical.

NOTE

Risk of data loss or irreparable damage to the memory card!

The device does not signal the respective access to the card used (read/write).

- If the parameter set is saved with the option "Save parameter permanently" in the device using SOPAS ET, do not remove the memory card during the process and do not switch off the supply voltage.

Technical data (excerpt)

Type	RFH630-1102101S05
Product category	ISO/IEC-15693 compatible read/write unit
Carrier frequency	HF (13.56 MHz)
Air interface protocol	ISO/IEC 15693, 18000-3 M1 ("mandatory" and "optional" command set)
Transmitting power	1 W
Scanning range write/read ¹⁾	Internal antenna: max. 10 mm
Transmission rate air interface	26 kBit/s
Typical access times	UID read (64 bit/8 byte): 18 ms 1 block read (32 bit/4 byte): 13 ms 1 Block write (32 bit/4 byte): 16 ms
Host interfaces	RS-232/422 (0.3 kBd ... 115.2 kBd) Ethernet TCP/IP (10/100 MBit/s) EtherNet/IP™ (10/100 MBit/s) PROFINET (single port, 10/100 MBit/s) CANopen (20 ... 1,000 kBd)
Host interfaces (also over external modules)	PROFIBUS via CDF600-2 PROFIBUS PROFINET via CDF600-2 PROFINET Dual Port EtherCAT® via CDF600 EtherCAT®
Aux interfaces (for configuration)	RS-232 (57.6 kBd) Ethernet TCP/IP (10/100 MBit/s)
SICK CAN Sensor Network	Via CAN interface
Switching inputs	2 x IN ($V_{in} = \max. 32 V$, $I_{in} = \max. 5 mA$), opto-decoupled, adjustable debounce time. 2 additional inputs via optional CMC600 module in optional CDB620-001 module

Type	RFH630-1102101S05
Switching outputs	2 x OUT (each $I_{out} \leq 100 mA$), not electrically isolated from the supply voltage, short-circuit protected, temperature protected. 2 additional outputs via optional CMC600 module in optional CDB620-001 module
Optical indicators	6 x status indicators LEDs (Ready, Result, RF, Data, CAN, LNK TX)
Function key	2 x, Read Diagnosis, additional functions can be adjusted via SOPAS ET
Parametric data backup	MicroSD card (optional) or external via optional CMC600 module in optional CDB620-001 connection module
Supply voltage V_s	10V DC ... 30 V DC, ES1 in accordance with currently applicable EN 62368-1
Power consumption	Max. < 6 W (with switching outputs without load)
Electrical connections	1 x male connector, M12, 17-pin, A-coded 1 x female connector, M12, 4-pin, D-coded 1 x female connector, TNC reverse
Housing	Aluminum die cast, plastic (PPS)
Weight	712 g
Safety	EN 62368-1
Enclosure rating	IP 67 (EN 60529:1991-10/A2:2000-02)
Protection class	III, (EN 61140:2011-01)
EMC	EN 301489-3 Receiver Class 2
Shock resistance	EN 60068-2-6:2008-02
Shock resistance	EN 60068-2-27:2009-05
Radio equipment approval	Europe EN 300 330-2 / FCC Part 15
Ambient temperature	Operation: -20 °C ... +50 °C Storage: -25 °C ... +70 °C
Relative humidity	0% ... 95%, non-condensing

1) With RFID transponder in plane parallel alignment to device antenna; depending on dimensions and quality of transponder.

Tab. 2: Technical specifications

For further technical specifications, see the online data sheet on the product page on the Internet at www.sick.com/RFH6xx.

Regulatory notes

Europe: Simplified EU declaration of conformity

SICK AG hereby declares that the RFH630-1102101S05 radio equipment complies with the 2014/53/EU directive. The complete text of the EU declaration of conformity is available at the following web address: www.sick.com/RFH6xx.

FCC approval

The device fulfills Part 15 of the FCC regulations:

The following prerequisites must be met:

- This device may not cause harmful interference, and this device must accept any interference received, including interference that may cause undesired operation.
- Any changes or modifications not expressly approved by the party responsible for compliance could void the user's authority to operate this device.

Operational restrictions

- **USA:** To comply with FCC part 15 rules in the United States, the system must be professionally installed to ensure compliance with the Part 15 certification. It is the responsibility of the operator and professional installer to ensure that only certified systems are deployed in the United States.

The use of the system in any other combination (such as co-located antennas transmitting the same information) is expressly forbidden. This equipment has been tested and found to comply with the limits for a Class A digital device, pursuant to part 15 of the FCC Rules. These limits are designed to provide reasonable protection against harmful interference when the equipment is operated in a commercial environment. This equipment generates, uses, and can radiate radio frequency energy and, if not installed and used in accordance with the instruction manual, may cause harmful interference to radio communications. Operation of this equipment in a residential area is likely to cause harmful interference in which case the user will be required to correct the interference at his own expense. Changes or modifications not expressly approved by the party responsible for compliance could void the user's authority to operate the equipment.

- **USA/Canada:** This device complies with part 15 of the FCC Rules and Industry Canada licence-exempt RSS standard(s) Operation is subject to the following two conditions: (1) This device may not cause harmful interference, and (2) this device must

accept any interference received, including interference that may cause undesired operation.

- **Canada:** This equipment complies with FCC radiation exposure limits set forth for an uncontrolled environment. This equipment should be installed and operated with minimum distance 20 cm between the radiator & your body. This Class A digital apparatus complies with Canadian ICES-003. This radio transmitter has been approved by Industry Canada to operate with the antenna types listed below with the maximum permissible gain and required antenna impedance for each antenna type indicated. Antenna types not included in this list, having a gain greater than the maximum gain indicated for that type, are strictly prohibited for use with this device.
 - Internal antenna:
Maximum permissible antenna gain: 2 dBi
Required impedance: 50 Ohm
 - External antenna RFA332:
Maximum permissible antenna gain: 2 dBi
Required impedance: 50 Ohm
- Under industry Canada regulations, this radio transmitter may only operate using an antenna of a type and maximum (or lesser) gain approved for the transmitter by Industry Canada. To reduce potential radio interference to other users, the antenna type and its gain should be so chosen that the equivalent isotropically radiated power (e.i.r.p.) is not more than that necessary for successful communication.
- **Canada:** This equipment complies with the Industry Canada RSS standards for license-exempt radio devices. Operation is subject to the following two conditions: (1) The device may not cause harmful interference, and (2) the device must accept any interference received, including if this may cause undesired operation. This equipment complies with the IC radiation exposure limits for uncontrolled environments. This equipment should be installed and used with a minimum distance of 20 cm between the radiator and the human body.
- This Class A digital equipment complies with the Canadian standard NMB-003..

Maintenance and care

The device does not contain any components that require maintenance.

Transport and storage

Transport and store the device in the original packaging, with protective plugs and caps fully screwed on. Do not store outdoors. To ensure that any residual moisture present can escape, do not store the device in airtight containers. Do not expose to any aggressive substances. Storage conditions: Dry, dust-free, no direct sunlight, as little vibration as possible, storage temperature $-25\text{ }^{\circ}\text{C}$ to $+70\text{ }^{\circ}\text{C}$, relative humidity max. 95% (non-condensing).

Repairs

Repair work on the device may only be performed by qualified and authorized service personnel from SICK AG.

Disassembly and disposal

Any device which can no longer be used must be disposed of in an environmentally friendly manner in accordance with the respective applicable country-specific waste disposal regulations. The device is electronic waste and must under no circumstances be disposed of with general waste!

Sources for additional information

You can obtain the Quickstart and further documentation online.

- Select your country and language at www.sick.com.
- Enter the device type designation or part number into the search field.
- Select the required device.
- All documentation and other downloadable content relating to the device can be found under Downloads.
The SOPAS ET configuration software can be downloaded under Software.
Documentation for the accessories that can be used can be downloaded under Accessories.

Function blocks for the device

www.sick.com/software

Documents on request

- Overview of the device command language

Support is also available from your sales partner:

www.sick.com/worldwide.

Device layout

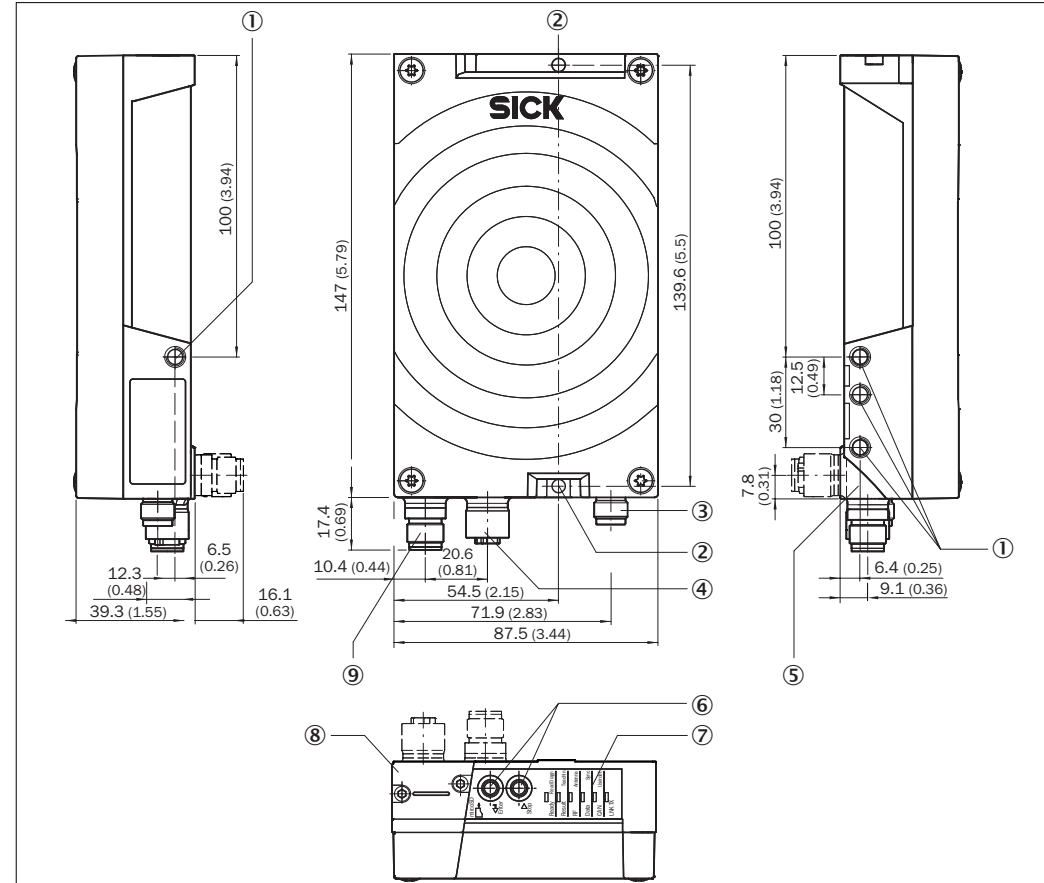
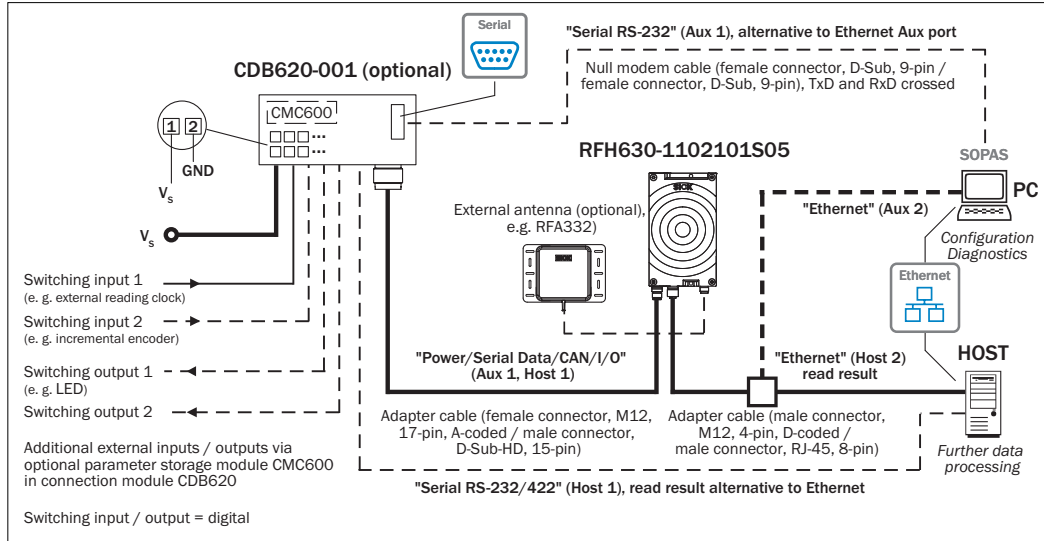

Fig. 9: Dimensions (in mm) and device structure

- ① 4 x M6 threaded mounting holes, 6.5 mm depth
- ② 2 x M5 through holes, 4.5 mm, as an alternative for mounting the device
- ③ Connection for external antenna (female connector, TNC reverse)
- ④ "Ethernet" connection (female connector, M12, 4-pin, D-coded)
- ⑤ Swivel connector
- ⑥ Function keys \blacktriangledown (Step) and \blackleftarrow (Enter)
- ⑦ 6 x RGB LEDs, multi-colored (status indicators)
- ⑧ Slot for microSD memory card, behind screw-mounted cover
- ⑨ "Power/Serial Data/CAN/I/O" connection (male connector, M12, 17-pin, A-coded)

Overview of all interfaces and connection options



Overview of pin assignments

Connection "Ethernet"

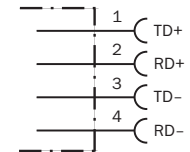
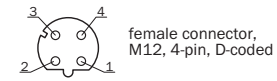

Connection "Power/Serial Data/CAN/I/O"

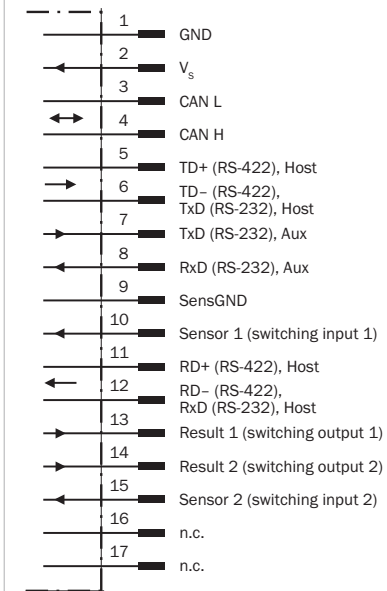
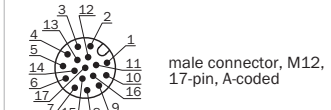



(Blank page)



(Blank page)

8023443/11W0/2018-11-20 • 8M_TM • Printed in Germany • All rights reserved • Subject to change without notice