

# **Annex no. 5**

# **User Manual**

## RFH630



RFID Interrogator (HF)

**SICK**  
Sensor Intelligence.



## Correct use

The RFH630 interrogator is an intelligent sensor for automatic, fixed identification and data feeding of wireless data carriers on moving or stationary objects. The RFH630 is designed as a compact read/write unit with integrated antenna and operates with all standard ISO/IEC15693-compatible transponders in the frequency range 13.56 MHz, either as a standalone device or coupled into a network. The RFH630 uses its host interface to transmit the read results to an overriding computer for further processing or it can receive corresponding commands for editing the data carrier (read, write, etc.).

The purpose of this instruction manual is to allow you to put the RFH630 into operation quickly and easily and to achieve initial read results with transponders. They describe the commissioning process for an application with a **single** RFH630.

The technical information contains more detailed information pertaining to the mechanical and electrical installation for the RFH630. Detailed information about configuration is available in the online help function of the SOPAS ET configuration software.

All information can be accessed on the enclosed data carrier

(DVD) or from the product site on the web ([www.mysick.com/de/RFH6xx](http://www.mysick.com/de/RFH6xx)).

## Safety information

- Read these instructions before commissioning the RFH630 in order to familiarize yourself with the device and its functions.
- Electrical connections between the RFH630 and other devices may only be connected or disconnected when the system is not live. Otherwise the devices may be damaged.
- Wire cross sections of the supply cable from the customer's power system should be designed in accordance with the applicable standards.
- Only use the RFH630 under permissible ambient conditions (e.g. temperature, ground potential) (→ see "Device structure RFH630", page 5).
- Protect the RFH630 against moisture and dust when the cover to the MicroSD card slot is open. The cover on the housing must be secured with screws in order to comply with enclosure rating IP 67 in operation. The same applies for protective caps/plugs on unused electrical connections.
- Do not open the RFH630 housing. If opened, any warranty claims against SICK AG are void.

## Commissioning and configuration

## Step 1: Electrical installation

1. Connect the communication interface of the RFH630 to the PC (e.g. Ethernet).
2. If the external antenna is being used (e.g. RFA332-2032, No. 1054399), connect it to the antenna input on the RFH630-1102101.

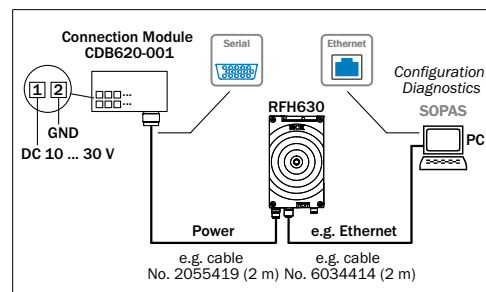

Electrical connection RFH630-1102101

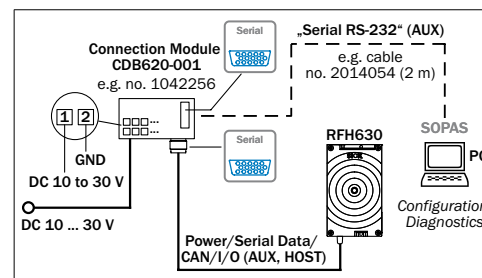

Electrical connection RFH630-100001

## Step 2: Mounting and alignment

1. Fix the mounting kit (optional accessory no. 2048551) to the RFH630.  
(→ see *Technical Information*, "Mounting" chapter). Alternatively, mount the RFH630 with 3 screws type M6 to a bracket supplied by the customer. Screw in the M6 screws to max. 6.5 mm into the mounting thread (→ see "Device description", page 2).
2. Align the surface of the integrated antenna on the RFH630 (front face) and where applicable the external antenna of the data carrier to the object. In doing so, take into consideration the alignment and dimensions of the antenna lobes. Avoid as far as possible any large metal surfaces positioned to the front.
3. Supply power to the RFH630.  
After successful initialization, the "Ready" LED illuminates green.
4. Ensure that no electrically conductive objects are positioned between the RFH630/antenna and the transponder during the read/write process. This would attenuate the generated HF field and thereby reduce the range of the RFH630.

## Scanning range of the read/write field on the RFH630

The maximum scanning range for communication between the RFH630 and transponder depends on various factors. Primarily, the dimensions of the transponder's antenna positively affects the scanning range. An additional factor for the scanning range is the quality of the transponder, for example, the antenna gain, the integrated transponder IC and its associated sensitivity. The specific reading field diagrams are available on the product website ([www.mysick.com](http://www.mysick.com)). The diagrams shown on page 4 depict the associated reading ranges for three different transponders (→ see "Reading field diagrams RFH630", page 4).

## Important

The specified values can only be achieved if the transponder is aligned parallel and evenly to the RFH630 antenna.



Alignment of RFH630 for discs, coins and ISO cards

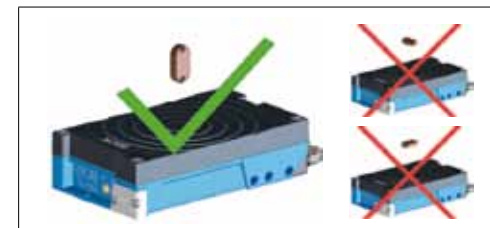

Alignment of RFH630 for on-metal transponders and glass transponders

## Step 3: Configuration to PC

Configuration of the RFH630 to the application as well as diagnostics in the event of malfunctions is undertaken by default with the SOPAS ET configuration software.

## Install and launch the SOPAS ET configuration software

1. Install the software on the PC from the enclosed "Software & Manuals Auto Ident" DVD (alternatively, download and install it from the website "[www.sick.com/software-und-downloads](http://www.sick.com/software-und-downloads)"). In this case, select the "Complete" option as selected by the install wizard. Administrator rights may be required on the PC to install the software.
2. Start the "SOPAS ET" program after completing the installation.  
Path: Start > Programs > SICK > SOPAS ET Engineering Tool > SOPAS.
3. Establish communication between SOPAS ET and RFH630 with the automatically launching wizard. In order to do so, select the available devices in accordance with the connected data interface, e.g. Ethernet on the RFH630.
4. The following IP address is configured by default on the RFH630:



5. SOPAS ET establishes communication with the RFH63x and loads the associated device description file for the RFH63x. The "Quickstart" tab opens automatically.

## Identifying the transponder

1. Bring one or more standards-compliant HF transponders into the working area of the internal antenna or where applicable the external antenna of the RFH630.
2. Click the "Start" button on the QUICKSTART page of the SOPAS ET. SOPAS ET generates an automatic reading cycle and lists the identified transponders one after the other on the QUICKSTART page.

## SOPAS ET Program Window

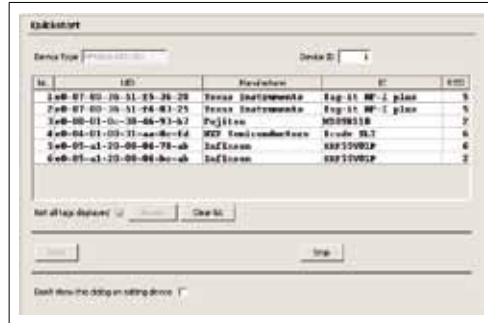

Display of six identified transponders in the QUICKSTART window

The process feedback LED in the center of the RFH630 device cover signifies in the default configuration if an HF field is available and a transponder is detected.

Lamp signal behavior blue LED	Meaning
Lights up with medium intensity	HF field available
High intensity slow flashing	1 transponder in field
High intensity rapid flashing	More than 1 transponder in field

## Accessing the data on a transponder

1. In order to access the memory area of a transponder in the RFH630 database (read/write), click the STOP button in QUICKSTART.
2. Mark the desired transponder (click it with the mouse).
3. Click the TRANSPONDER ACCESS button.  
The TRANSPONDER USER DATA tab displays the content of the selected transponder.

Display window TRANSPONDER USER DATA

## Important

The UID (Unique Identifier) of the transponder cannot be changed.

## Continuing configuration

1. Use the navigation tree in SOPAS ET and with the help of the other entries under parameter, edit the required tabs for the application (among other things, transponder communication, trigger control, data processing and output, data output interface(s) as well as switching inputs and outputs).
2. Test and if necessary modify the settings made when operating the system under real conditions.

## Complete the configuration

- Permanently save the entire configuration:  
Parameter set in RFH630: click the button  
Configuration file on the PC: click the button.

## Description of the device

### Device structure RFH630-1102101

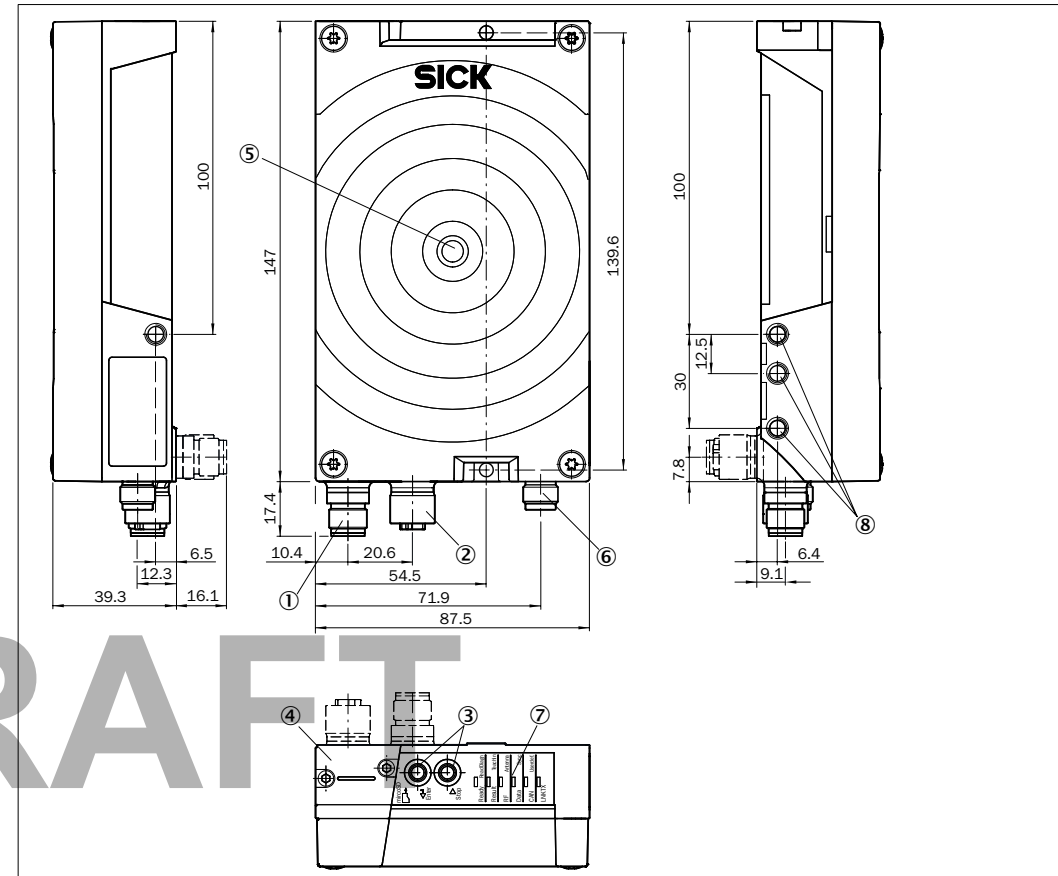

- ① connection "Power / Serial Data / CAN / I/Os" (17-pin M12-plug, A-coded)
- ② "Ethernet" connection (4-pin M12 socket, D coded)
- ③ Function keys (Step) and (Enter)
- ④ Slot for MicroSD card, behind threaded cover
- ⑤ Process Feedback LED
- ⑥ Antenna output (TNC socket)
- ⑦ 6 x status LEDs
- ⑧ Mounting thread M6, 6.5 mm depth

Device structure RFH630-1000001

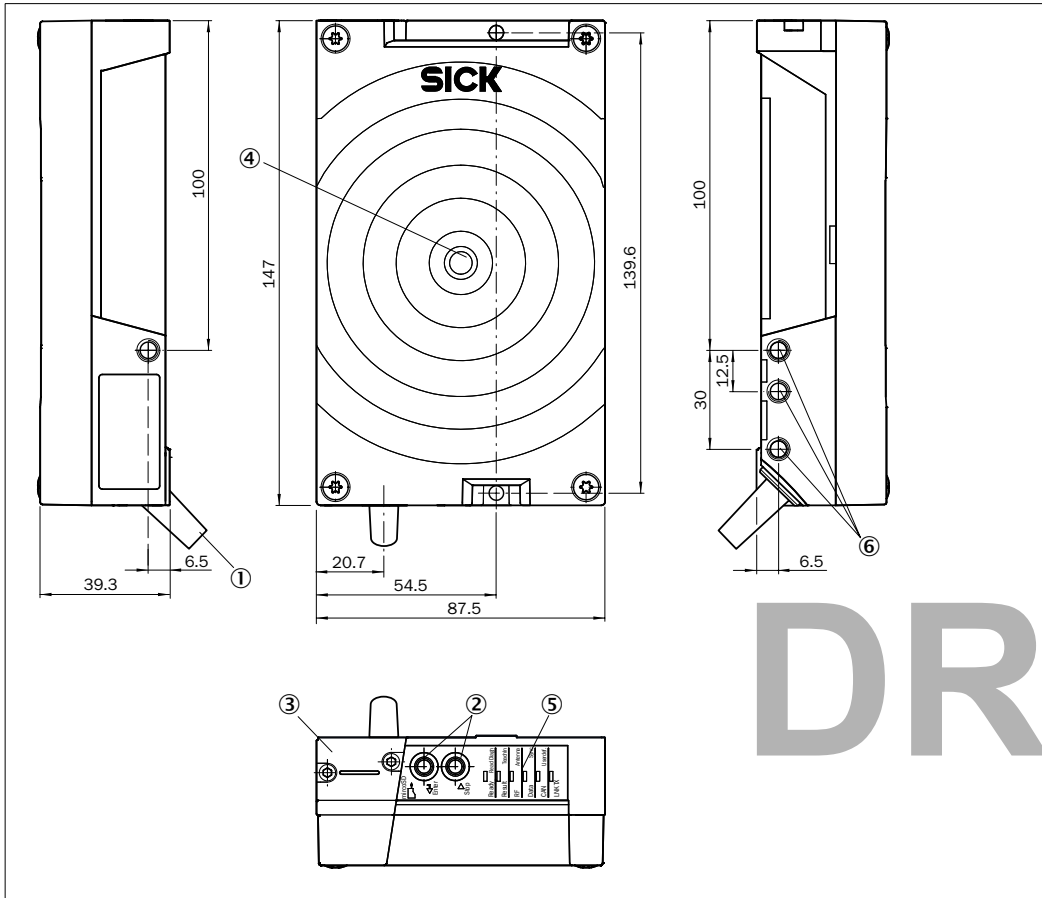

- ① Cable 0.9 m with D-Sub-HD plug (15-pin)
- ② Function keys ▼ (Step) and ◀ (Enter)
- ③ Slot for MicroSD card, behind threaded cover
- ④ Process Feedback LED
- ⑤ 6 x status LEDs
- ⑥ Mounting thread M6, 6.5 mm depth

Status indicators, function keys, functions

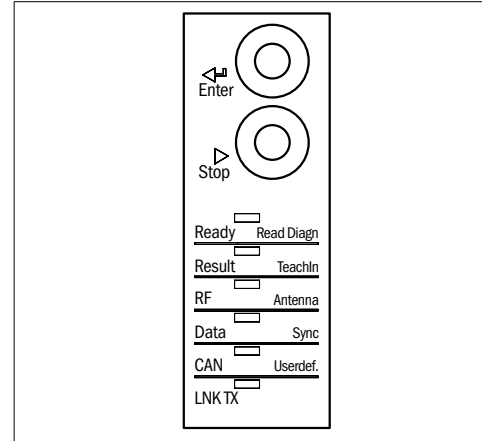

LED status indicators and function keys

Key	Function
▶ (Step)	Select function.
◀ (Enter)	Start or quit function.

Display	LED	Status
Ready	● Green	Lights up constantly after switching on and completion of successful self-test.
	●	Goes out when downloading or uploading configuration data from and to the RFH630
Result	● Green	Successful read process (good read, 100 ms)
RF	● Green	Antenna field activated (dependent on read cycle)
Data	● Green	Data transfer via serial host interface (Rx/D)
	● Yellow	Data transfer via serial host interface (Tx/D)
CAN	● Green	CAN-interface activated
	● Green	Data transfer via CAN interface
LNK TX	● Green	Data transfer via Ethernet interface
	● Yellow	Physical Ethernet connection

● = illuminated; ● = flashes

MicroSD memory card (optional accessory)

Function

An insertable memory card can be used with the RFH630 to store the last modified parameter set (cloning). The memory card is not included in the scope of delivery.

Insert memory card

Only use types approved by SICK to ensure reliable function of the memory card.

The card slot (→ see "Device Description", page 2) can be accessed on the RFH630 behind the aluminum cover.

NOTE

Risk of data loss or irreparable damage to the memory card

- Never remove the memory card during the write process.
- Do not turn off the supply voltage.

## Overview of all interfaces and connection options

### RFH630-1102101

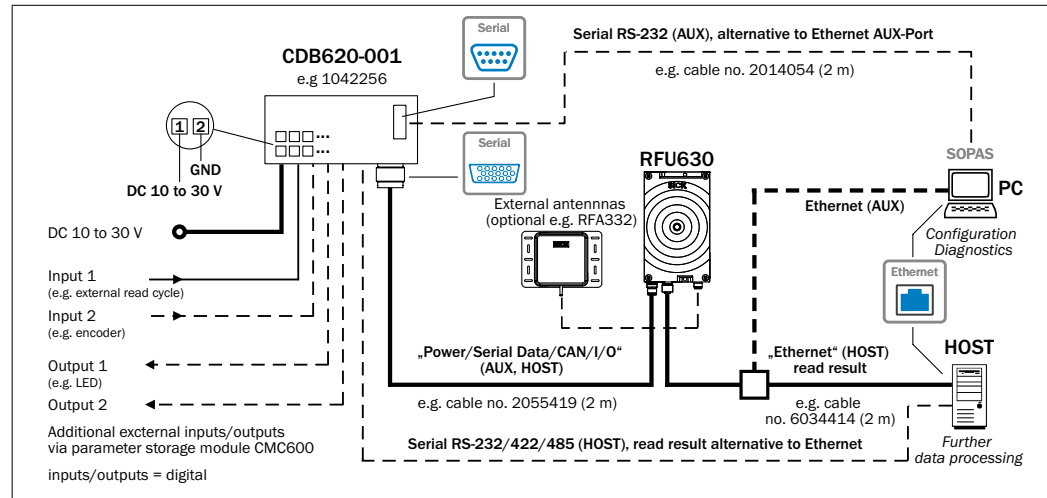

### RFH630-1000001

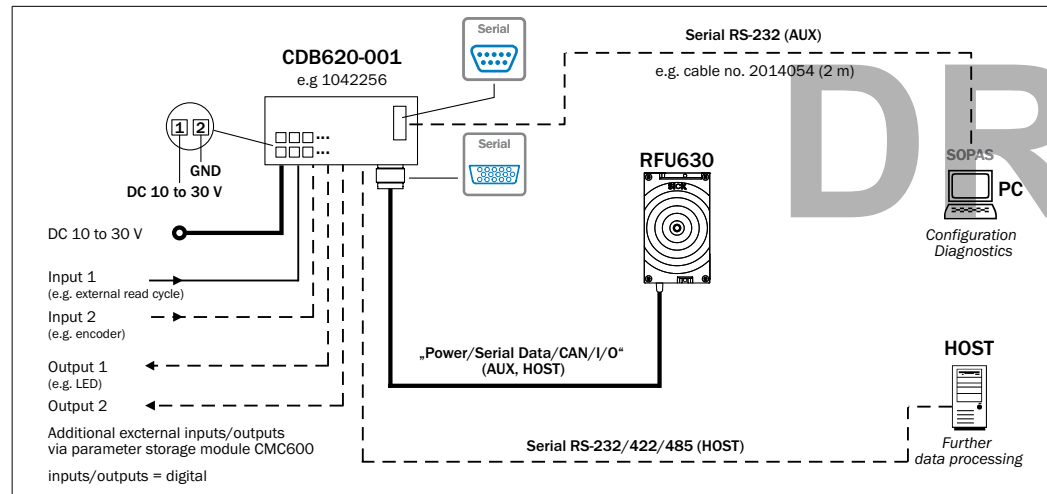

## Overview of pin assignment

### Connection "Power/Serial Data/CAN/I/O"

#### 17-pin plug on RFH630

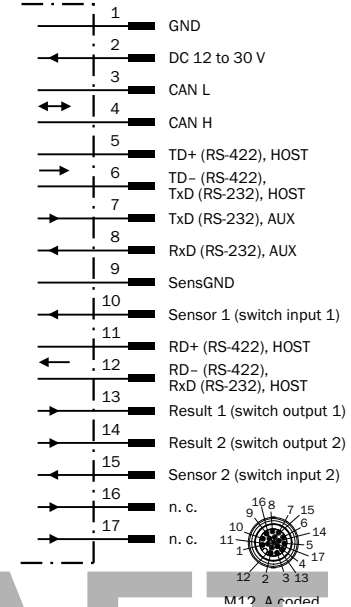

#### 15-pin plug on cable e.g. no. 2055419 (2 m)

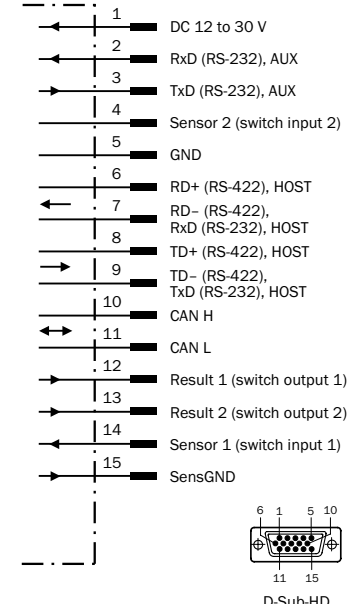

### Ethernet connection

#### 4-pin socket on RFH630

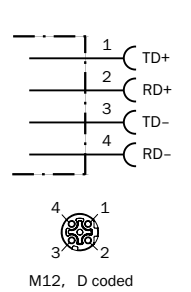

## Reading field diagrams RFH630

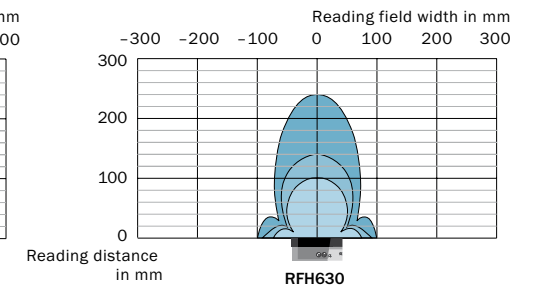
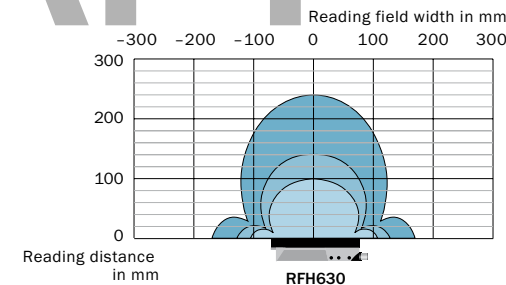

- Coin 16
- Disc 30
- ISO Card

## Technical specifications (excerpt)

Model name	RFH630
Product category	ISO/IEC 15693 Interrogator (read/write unit)
Frequency band	HF (13.56 MHz)
Protocol air interface	ISO/IEC 1569, 18000-3M1 ("mandatory" and "optional" command set)
Transmitting power	1000 mW
Scanning range write/read <sup>1)</sup>	Internal antenna: up to 240 mm External antenna: RFA332: up to 360 mm
Transmission rate air interface	26 kBit/s
Typical access times	UID read (64 bit/8 byte): 18 ms 1 block read (32 bit/4 byte): 13 ms 1 Block write (32 bit/4 byte): 16 ms
Host interfaces (internal)	RFH630-1000001: • RS-232/422/485 (0.3 to 115.2 kBd) • CANopen (20 to 1000 kBd) RFH630-1102101: • RS-232/422/485 (0.3 to 115.2 kBd) • Ethernet TCP/IP (10/100 MBit/s) • Ethernet IP (10/100 MBit/s) • CANopen (20 to 1000 kBd)
Host interfaces (external)	PROFIBUS via CDF600-0100 PROFINET via CDM425 EtherCAT via CDF600-0300
Aux interfaces (for configuration)	RFH630-1000001: • RS-232 (57.6 kBd) RFH630-1102101: • RS-232 (57.6 kBd) • Ethernet TCP/IP (10/100 MBit/s)
SICK CAN Sensor Network	Via CAN interface
Input signal switching devices	2 x IN ( $I_e = \max. 32 \text{ V}$ , $I_e = \max. 5 \text{ mA}$ ), opto-decoupled, debouncing time configurable, 2 additional inputs via module CMC600 in module CDB620
Output signal switching device	2 x OUT (each $I_e = \leq 100 \text{ mA}$ ), not galvanically isolated from the supply voltage, short-circuit protection/temperature protection, 2 additional inputs via module CMC600 in module CDB620
Acoustic indicators	Beeper, function configurable via SOPAS
Optical indicators	1 x LED (Process Feedback) center front, function/color configurable via SOPAS 6 x LEDs for status signaling (Ready, Result, RF, Data, CAN, LNK TX)
Function key	2 x, Read Diagnosis, additional functions configurable via SOPAS
Parametric data backup	MicroSD card (optional) or external via module CMC600 in connection module CDB620-001
Supply voltage	DC 10 ... 30 V, PELV according to EN 61140 (2002-03)
Power consumption	Max. < 6 W (with output signal switching device unloaded and full transmission power)
Electrical connections	RFH630-1102101: • 1 x 17-pin. M12 round plug • 1 x 4-pin. M12 round socket • 1 x TNC RFH630-1000001: • 1 x 15-pin. Cable with D-sub-HD plug
Housing	Cast aluminum, plastic (PPS)

Model name	RFH630
Weight	RFH630-1102101: • 712 g RFH630-1000001: • 756 g
Enclosure rating	IP 67 (EN 60529: 1991-10/A2: 2000-02)
Ambient temperature range	Operation: -20 °C to +50 °C Storage: -25 °C to +70 °C
Relative air humidity	0 to 95%, non-condensing
Vibration resistance	EN 60068-2-6: 2008-02
Shock resistance	EN 60068-2-27: 2009-05
Protection class	III, (EN 61140: 2011-01)
Electrical safety	EN 60950-1: 2006-04/A11: 2009-03
CE-conformity	EN 301 489-3 V1.4.1 Receiver Class 2
Radio equipment type approval	Europe EN 300 330-2 (V1.5.1)/FCC Part 15
1) with RFID ISO card transponder in plane parallel alignment to RFH630 antenna; depending on dimensions and quality of transponder	

For further technical specifications, see the Online data sheet on the product site on the web ([www.mysick.com/de/rfh63x](http://www.mysick.com/de/rfh63x))

## Warnings

### ⚠ WARNING

#### Danger of potential equalization currents

The RFH630 is designed to be operated in a system with proficient grounding of all connected devices and mounting surfaces to the same ground potential. If this condition is not met, potential equalization currents may flow along the cable shields, leading to the following dangers:

- Dangerous contact voltage on the metal housing
- Malfunction or destruction of the RFH630
- Heating of the cables until spontaneous combustion

➤ See the "Electrical installation" chapter in the *Technical information* on the enclosed DVD or on the product site on the web ([www.mysick.com/de/rfh63x](http://www.mysick.com/de/rfh63x)) for measures to eliminate hazards.

## FCC approval

The RFH630 fulfills part 15 of the FCC regulations:

The following prerequisites must be met:

- This device may not cause harmful interference, and
- this device must accept any interference received, including interference that may cause undesired operation.
- Any changes or modifications not expressly approved by the party responsible for compliance could void the user's authority to operate this equipment.

## Items supplied

- RFH630 of the type ordered, equipped with protective caps / plugs on the electrical connections
- "Software & Manuals Auto Ident" DVD (no. 2039442)
- Printed operating instructions in German and English; in other languages as PDF on the DVD if required
- Optionally ordered accessories if applicable

## Maintenance and care

The RFH630 does not contain any components that require maintenance.

## Sources for obtaining additional information

Additional information about the RFH630 and its optional accessories can be found in the following places:

### "Software & Manuals Auto Ident" DVD (no. 2039442)

- RFH630 technical information (supplementary information, e.g. for mounting, electrical installation)
- These operating instructions in German and English
- Configuration software SOPAS ET with integrated online help function
- Ordering information in the product information RFH630
- Product catalog identification solutions
- Publications dealing with the accessories

### Product web page for the RFH630 ([www.mysick.com/de/rfh63x](http://www.mysick.com/de/rfh63x))

- Suitable accessories
- Detailed technical specifications (online data sheet)
- Dimensional drawing and 3D CAD dimension models in various electronic formats
- Product catalog identification solutions
- RFH630 product information
- RFH630 operating instructions in German and English, in other languages if necessary
- EC-Declaration of Conformity
- SOPAS ET configuration software updates
- All publications contained on the aforementioned DVD (via links)

Support is also available from your sales partner: [www.sick.com/worldwide](http://www.sick.com/worldwide).

### Documents on request

- Overview of RFH630 command strings

**Support is also available from your sales partner: [www.sick.com/worldwide](http://www.sick.com/worldwide).**

# DRAFT