

Partial Test Report

20-1-0017102T02a



Deutsche
Akreditierungsstelle
D-PL-12047-01-01
D-PL-12047-01-03
D-PL-12047-01-04

Number of pages:	26	Date of Report:	2021-Mar-16
Testing company:	CETECOM GmbH Im Teelbruch 116 45219 Essen Germany Tel. + 49 (0) 20 54 / 95 19-0 Fax: + 49 (0) 20 54 / 95 19-150	Applicant:	SICK AG
Test Object / Tested Device(s):	UWB Tag, LOCU101-0110		
FCC ID:	WRMLOCU1	IC:	10066A-LOCU1

Testing has been carried out in accordance with:	Title 47 CFR, Chapter I FCC Regulations, Subchapter A §15.247 (DTS) ISED-Regulations RSS-Gen, Issue 5 RSS 247, Issue 2 Deviations, modifications or clarifications (if any) to above mentioned documents are written in each section under "Test method and limit".
---	---

Tested Technology:	2.4 GHz WPAN according to IEEE 802.15.1
---------------------------	--

Test Results:	<input checked="" type="checkbox"/> The EUT complies with the requirements in respect of selected parameters subject to the test. The test results relate only to devices specified in this document
----------------------	--

Signatures:	
	Dipl.-Ing. Ninovic Perez Test Lab Manager Authorization of test report
	Mohamed Ahmed Test manager Responsible of test report

Table of Contents

Table of Annex.....	2
1.1 Disclaimer and Notes.....	3
1.1. Summary of Test Results	4
1.2. Summary of Test Methods	5
2.1 Identification of the Testing Laboratory	6
2.2 General limits for environmental conditions.....	6
2.3 Test Laboratories sub-contracted.....	6
2.4 Organizational Items	6
2.5 Applicant’s details	6
2.6 Manufacturer’s details	6
2.7 EUT: Type, S/N etc. and short descriptions used in this test report	7
2.8 Auxiliary Equipment (AE): Type, S/N etc. and short descriptions.....	7
2.9 Connected cables	7
2.10 Software.....	7
2.11 EUT set-ups	7
2.12 EUT operation modes.....	8
3.1 General Data of Main EUT as Declared by Applicant.....	9
3.2 Detailed Technical data of Main EUT as Declared by Applicant	9
3.3 Modifications on Test sample.....	9
4.1 Duty-Cycle	10
4.2 Peak output power (Sweep)	11
4.3 Radiated field strength emissions below 30 MHz	13
4.4 Radiated field strength emissions 30 MHz – 1 GHz.....	17
4.5 Radiated field strength emissions above 1 GHz	19
4.6 Radiated Band-Edge emissions.....	21
4.7 Results from external laboratory.....	23
4.8 Opinions and interpretations	23
4.9 List of abbreviations	23

Table of Annex			
Annex No.	Contents	Reference Description	Total Pages
Annex 1	Test result diagrams	CETECOM_TR20-1-0017102T02a_A1	19
Annex 2	Internal photographs of EUT	CETECOM_TR20-1-0017102T02a_A2	4
Annex 3	External photographs of EUT	CETECOM_TR20-1-0017102T02a_A3	9
Annex 4	Test set-up photographs	CETECOM_TR20-1-0017102T02a_A4	7
Annex 5	LOCU1xxx HW change description v1.2	CETECOM_TR20-1-0017102T02a-A5	4
The listed attachments are separate documents.			

1 General information

1.1 Disclaimer and Notes

The test results of this test report relate exclusively to the test item specified in this test report as specified in chapter 2.7. CETECOM does not assume responsibility for any conclusions and generalizations drawn from the test results with regard to other specimens or samples of the type of the equipment represented by the test item.

The test report may only be reproduced or published in full. Reproduction or publication of extracts from the report requires the prior written approval of CETECOM.

The testing service provided by CETECOM has been rendered under the current "General Terms and Conditions for CETECOM". CETECOM will not be liable for any loss or damage resulting from false, inaccurate, inappropriate or incomplete product information provided by the customer.

Under no circumstances does the CETECOM test report include any endorsement or warranty regarding the functionality, quality or performance of any other product or service provided.

Under no circumstances does the CETECOM test report include or imply any product or service warranties from CETECOM, including, without limitation, any implied warranties of merchantability, fitness for purpose, or non-infringement, all of which are expressly disclaimed by CETECOM.

All rights and remedies regarding vendor's products and services for which CETECOM has prepared this test report shall be provided by the party offering such products or services and not by CETECOM.

In no case this test report can be considered as a Letter of Approval.

This test report is electronically signed and valid without handwritten signature. For verification of the electronic signatures, the public keys can be requested at the testing laboratory.

The test report must always be reproduced in full; reproduction of an excerpt only is subject to written approval of the testing laboratory. The documentation of the testing performed on the tested devices is archived for 10 years at CETECOM.

Also we refer on special conditions which the applicant should fulfill according §2.927 to §2.948, special focus regarding modification of the equipment and availability of sample equipment for market surveillance tests.

1.1. Summary of Test Results

The EUT integrates a 2.4 GHz WPAN according to IEEE 802.15.1 transmitter. Other implemented wireless technologies were not considered within this test report.

Test case	Reference Clause FCC <input checked="" type="checkbox"/>	Reference Clause ISED <input checked="" type="checkbox"/>	Page	Remark	Result
Duty-Cycle	§15.35(c)	RSS-Gen Issue 5, §8.2	10	--	PASSED
Minimum Emission Bandwidth 6 dB	§15.247 5.2(a)	RSS-247, § 5.2(a) RSS-Gen Issue 5,; § 6.7	--	1	NP
Occupied Channel Bandwidth 99%	2.1049(h)	RSS-Gen Issue 5, § 6.7	--	1	NP
Peak output power (Sweep)	§15.247(b)(3)	RSS-247, § 5.4(d)	11		PASSED
Transmitter Peak output power radiated	§15.247(b)(4)(c)(i)	RSS-247, § 5.4(d)	--	1	NP
Emissions in non-restricted frequency bands	§15.247(d)	RSS-247, § 5.5	--	1	NP
Radiated Band-Edge emissions	§15.205(b) §15.247(d)	RSS-Gen: Issue 5 §8.9, §8.10 RSS-247, § 5.5	21	--	PASSED
Power spectral density	§15.247(e)	RSS-247, § 5.2(b)	--	1	NP
Radiated field strength emissions below 30 MHz	§15.205(a) §15.209(a)	RSS-Gen: Issue 5 §8.9 Table 6	13	--	PASSED
Radiated field strength emissions 30 MHz – 1 GHz	§15.209 §15.247(d)	RSS-Gen: Issue 5 §8.9 Table 5 RSS-247, § 5.5	17	--	PASSED
Radiated field strength emissions above 1 GHz	§15.209(a) §15.247(d)	RSS-Gen: Issue 5: §8.9 Table 5+7 RSS-247, § 5.5	19	--	PASSED
AC-Power Lines Conducted Emissions	§15.207	RSS-Gen Issue 5: § 8.8, Table 4	--	1	NP

PASSED The EUT complies with the essential requirements in the standard.
 FAILED The EUT does not comply with the essential requirements in the standard.
 NP The test was not performed by the CETECOM Laboratory.
 NT Not tested
 N/A Not applicable

Remark:

- 1) for details please refer to modules test report 393-18 with the **FCC ID 2AQ33-DWM1001** and **IC: 23794-DWM1001** issued on 16-Nov-2018.

*The calculation of the measurement uncertainty shows compliance with the "maximum measurement uncertainties" of the tested standard and therefore for result evaluation the stated uncertainties will not be additionally added to the measured results.

1.2. Summary of Test Methods

Test case	Test method
Duty-Cycle	ANSI 63.10:2013, §11.6(b)
Minimum Emission Bandwidth 6 dB	ANSI C63.10:2013, §6.9.2, §11.8
Occupied Channel Bandwidth 99%	ANSI C63.10:2013, §6.9.3
Peak output power (Sweep)	ANSI C63.10:2013, §11.9
Power spectral density	ANSI C63.10:2013, §11.10
Emissions in non-restricted frequency bands	ANSI C63.10:2013, §11.11, §6.10.5
Radiated Band-Edge emissions	ANSI C63.10-2013; "Marker-Delta method", §6.10.5, §11.13
Transmitter Peak output power radiated	Result calculated with measured conducted RF-power value and stated/measured antenna gain for band of interest
Radiated field strength emissions below 30 MHz	ANSI C63.10-2013 §6.3, §6.4
Radiated field strength emissions 30 MHz- 1 GHz	ANSI C63.4-2014 §8.2.3, ANSI C63.10-2013 §6.3, § 6.5
Radiated field strength emissions above 1 GHz	ANSI C63.4-2014 §8.3, ANSI C63.10-2013 §6.3, § 6.6
AC-Power Lines Conducted Emissions	ANSI C63.4-2014 §7, ANSI C63.10-2013 § 6.2

And reference also to Test methods in KDB558074

2 Administrative Data

2.1 Identification of the Testing Laboratory

Company name:	CETECOM GmbH
Address:	Im Teelbruch 116 45219 Essen - Kettwig Germany
Responsible for testing laboratory:	Ninovic Perez
Accreditation scope:	DAkkS Webpage
Test location:	CETECOM GmbH; Im Teelbruch 116; 45219 Essen - Kettwig

2.2 General limits for environmental conditions

Temperature:	22±2 °C
Relative. humidity:	45±15% rH

2.3 Test Laboratories sub-contracted

Company name:	
---------------	--

2.4 Organizational Items

Order No.:	
Responsible test manager:	Mohamed Ahmed
Receipt of EUT:	2020-Jun-18
Date(s) of test:	2020-Dec-22 – 2021-Jan-07
Version of template:	14.4

2.5 Applicant's details

Applicant's name:	SICK AG
Address:	Erwin-Sick-Str. 1 79183 Waldkirch Germany
Contact Person:	Tobias Hofmann
Contact Person's Email:	Tobias.hofmann@sick.de

2.6 Manufacturer's details

Manufacturer's name:	Same as applicant's details
Address:	Same as applicant's details

2.7 EUT: Type, S/N etc. and short descriptions used in this test report

Short description*)	PMT Sample No.	EUT	Type	S/N	HW status	SW status
EUT 01	20-1-00171S26_C01	UWB Tag	LOCU101-0110	2035 0004	v1r3	3.125.7
EUT 02	20-1-00171S38_C01	UWB Tag	LOCU101-0110 (conducted)	2048 0003	v1r3	3.125.7
EUT 03**)	20-1-00171S26_C01	UWB Tag	LOCU101-0110	2035 0004	v1r3 .1	3.125.7

*) EUT short description is used to simplify the identification of the EUT in this test report.

***) The listed additional variants/models are not tested nor object of evaluated of compliance. For further information please see annex 5.

2.8 Auxiliary Equipment (AE): Type, S/N etc. and short descriptions

Short description*)	PMT Sample No.	Auxiliary Equipment	Type	S/N	HW status	SW status
AE 01	20-1-00171S29_C01	Battery	LP-402933-1S-3	N/A	3.7V - 300 mAh	N/A
AE 02	20-1-00171S30_C01	USB-UART Adapter	FTDI LC234X	N/A	N/A	N/A
AE 03	--	Notebook	Dell Latitude CTC522013	DPN:VVF52 A01	Intel core i5	Windows 7

*) AE short description is used to simplify the identification of the auxiliary equipment in this test report.

2.9 Connected cables

Short description*)	PMT Sample No.	Cable type	Connectors	Length
CAB 01	20-1-00171S34_C01	USB Cable	USB to Micro USB	1m
CAB 02	--	Power Supply Cable	--	0.9m
CAB 03	--	Power Supply cable	--	0.06m

*) CAB short description is used to simplify the identification of the connected cables in this test report.

2.10 Software

Short description*)	PMT Sample No.	Software	Type	SW status
SW 01	--	putty	SSH SW	0.74

*) SW short description is used to simplify the identification of the used software in this test report.

2.11 EUT set-ups

set-up no.*)	Combination of EUT and AE	Description
01	EUT 01 + AE 01** + (AE 02 + AE 03 + CAB 01)*** + CAB 02 + CAB 03	Used for Radiated measurements
02	EUT 02 + AE 01** + AE 02 + AE 03 + CAB 01 + CAB 02 + CAB 03	Used for Conducted measurements

*) EUT set-up no. is used to simplify the identification of the EUT set-up in this test report.

***) AE 01 was installed but not connected during the tests due to low battery level, instead CAB 02 + CAB 03 were used.

****) only used for setting the operating mode and were placed outside the test chamber

2.12 EUT operation modes

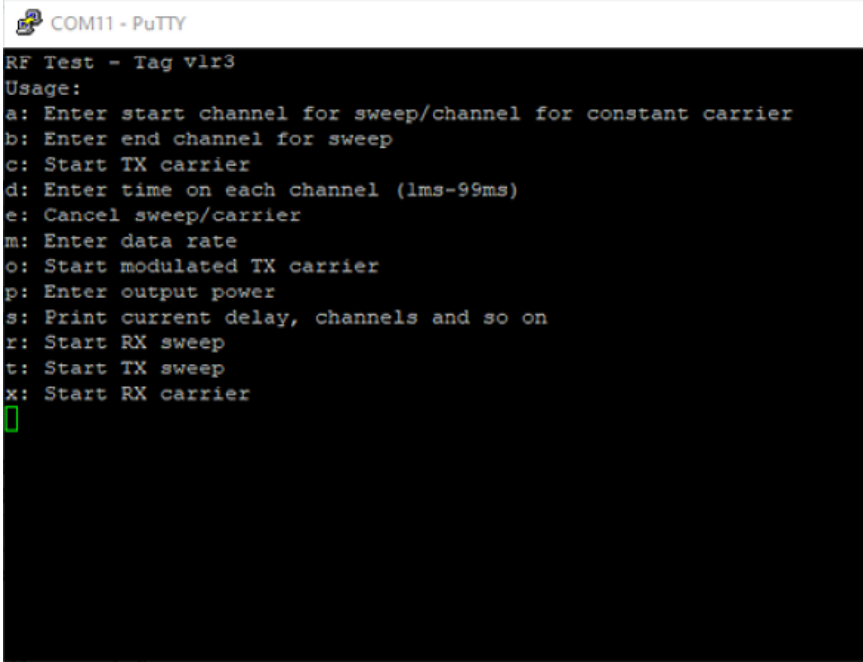
EUT operating mode no. *)	Operating modes	Additional information
op. 1	TX-Mode	<p>With help of terminal client (Putty) TX-mode was set-up via AE 02 and AE 03 We refer to applicants information/papers for details about necessary commands. Settings in SW were: Power = 4 and Datarate = 1 Mbps and Modulated carrier was set.</p>  <pre> COM11 - PuTTY RF Test - Tag v1r3 Usage: a: Enter start channel for sweep/channel for constant carrier b: Enter end channel for sweep c: Start TX carrier d: Enter time on each channel (1ms-99ms) e: Cancel sweep/carrier m: Enter data rate o: Start modulated TX carrier p: Enter output power s: Print current delay, channels and so on r: Start RX sweep t: Start TX sweep x: Start RX carrier </pre>

*) EUT operating mode no. is used to simplify the test report.

3 Equipment under test (EUT)

3.1 General Data of Main EUT as Declared by Applicant

Product name	UWB Tag		
Kind of product	LOCU101-0110		
Firmware	<input type="checkbox"/> for normal use	<input checked="" type="checkbox"/> Special version for test execution	
	<input type="checkbox"/> AC Mains	-	
	<input type="checkbox"/> DC Mains	3.7 V DC via CAB 02 Connector	
	<input checked="" type="checkbox"/> Battery	Lithium Polymer (LiPo)	
Operational conditions	T _{nom} =23 °C	T _{min} =-20 °C	T _{max} =60 °C
EUT sample type	Pre-Production		
Weight	45g		
Size	90.2mmx42.9mmx15.5mm		
Interfaces/Ports	--		
For further details refer Applicants Declaration & following technical documents			
For further details regarding radio parameters, please refer to IEEE15.4.1 Specification			

3.2 Detailed Technical data of Main EUT as Declared by Applicant

Frequency Band	2.4 GHz ISM Band (2400 MHz - 2483.5 MHz)		
Number of Channels (USA/Canada -bands)	40 (37 Hopping + 3 Advertising)		
Nominal Channel Bandwidth	1 MHz		
Type of Modulation Data Rate	<input checked="" type="checkbox"/> GFSK 1 Mbit / s	<input type="checkbox"/> GFSK 2 Mbit / s	
	<input type="checkbox"/> GFSK 500 kbit / s	<input type="checkbox"/> GFSK 125 kbit / s	
Other wireless options	<input type="checkbox"/> UWB (not tested within this test report)		
Max. Conducted Output Power	GFSK 3.2 dBm		
EIRP Power (Calculated EIRP)	GFSK 3.2 dBm + 0.5 dBi = 3.7 dBm		
Antenna Type(s)	Chip antenna		
Antenna Gain(s)	0.5 dBi		
FCC label attached	Yes		
Test firmware / software and storage location	SW 01 was saved on AE 3, and terminal connection could be established to EUT 01 and EUT 02		
For further details refer Applicants Declaration & following technical documents			
Description of Reference Document (supplied by applicant)	Version	Total Pages	
LOCU UWB tag-operating instructions for certification testing issued on 11.09.2020	V1.3	23	
8024844__Quickstart_A4-tag_v2.3	V2.3	3	

3.3 Modifications on Test sample

Additions/deviations or exclusions	AE 01(Battery) was installed but not connected during the tests due to low battery level, instead CAB 02 and CAB 03 were used.
------------------------------------	--

4 Measurements

4.1 Duty-Cycle

Testing method:

The measurement is made according to relevant reference clauses:
(See Tables *Summary of Test Results* and *Summary of Test Methods* on page 5)

The necessary duty-cycle correction factor is determined on nominal conditions on middle channel only. It is assumed that no noticeable changes occur when tested on other channels or climatic conditions.

EUT settings

The EUT was instructed to send with maximum power (if adjustable) according applicants instructions. Different modulation characteristics have been checked, e.g. data rates which EUT can operate.

A special firmware program is used for test purposes. In opposite to normal operating mode a higher duty-cycle is set in order to facilitate the measurements. This is maximized at the extent possible.

The necessary duty-cycle correction factor is determined on nominal conditions on one channel in each operable frequency-band. It is assumed that no noticeable changes occur when tested on other channels or climatic conditions. The Duty-Cycle was constant, means without variations.

Formula to calculate Duty-Cycle:

Duty cycle calculations: $x = \frac{TX_{ON}}{TX_{ON} + TX_{OFF}}$	Duty cycle factor: DC=	Regarding power: $10 * \log(1/x)$ dB
		Regarding field strength: $20 * \log(1/x)$ dB

- The results were corrected in order to evaluate for worst-case result each time when average values are necessary for example average radiated emissions or similar
- No correction necessary: Duty-Cycle > 98%

4.1.1 Measurement Location

Test site	120910 - Radio Laboratory 1 (TS 8997)
------------------	---------------------------------------

4.1.2 Result

Duty-Cycle [%]	Duty-Cycle correction Power [dB]	Duty-Cycle correction Field Strength [dB]
94.798	--	0.46
94.797	--	0.46
94.796	--	0.46
94.796	--	0.46

4.2 Peak output power (Sweep)

4.2.1 Description of the general test setup and methodology, see below example:

The EUT's RF-signal is coupled out by a suitable antenna coupling connector (1). The signal is first attenuated (2) then connected to power meter (3) or spectrum-analyzer (4) for RF-conducted measurements. The specific attenuation loss is determined prior to the measurement within a set-up attenuation measurement. These are then taken into account by correcting the measurement readings.

Schematic:

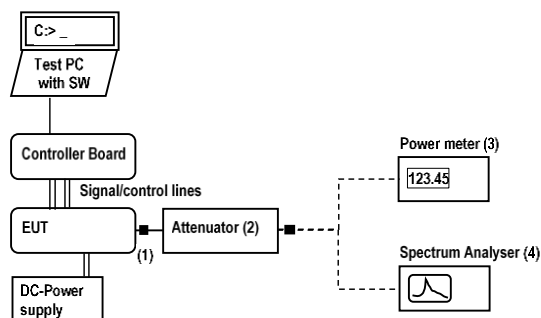

Testing method:

The measurement is made according to relevant reference clauses:
(See Tables *Summary of Test Results* and *Summary of Test Methods* on page 5)

Measurement is made using Rohde & Schwarz TS8997 test system.

Test method	Maximum peak conducted output power(RBW = DTS-bandwidth of the signal)
Remarks	--

The measurement was performed in non-hopping transmission mode with the carrier set to lowest/middle and highest channel.

EUT settings

The EUT was instructed to send with maximum power (if adjustable) according applicants instructions. Different modulation characteristics have been checked, e.g. data rates which EUT can operate

4.2.2 Measurement Location

Test site	120910 - Radio Laboratory 1 (TS 8997)
------------------	---------------------------------------

4.2.3 Limit

Frequency Range [MHz]	Limit [W]	Limit [dBm]	Detector	RBW / VBW [MHz]
2400 - 2483.5	1	30	MaxPeak	3 / 10

4.2.4 Result

Mode	Channel	Frequency [MHz]	Max Peak Power [dBm]	Result
1 MBps PWR4	00	2402.000000	3.1	Passed
1 MBps PWR4	39	2440.000000	3.1	Passed
1 MBps PWR4	41	2442.000000	3.1	Passed
1 MBps PWR4	80	2480.000000	3.2	Passed

Remark: for more information and graphical plot see annex A1 **CETECOM_TR20-1-0017102T02a_A1**

4.3 Radiated field strength emissions below 30 MHz

4.3.1 Description of the general test setup and methodology, see below example:

Evaluating the radiated field emissions are done first by an exploratory emission measurement and a final measurement for most critical frequencies determined.

The loop antenna was placed at 1 m height above ground plane and 3 m measurement distance from set-up for investigations. Because of reduced measurement distance, correction data were applied, as stated in chapter "General Limit - Radiated field strength emissions below 30 MHz". The tests are performed in the semi anechoic room recognized by the regulatory commission.

Schematic:

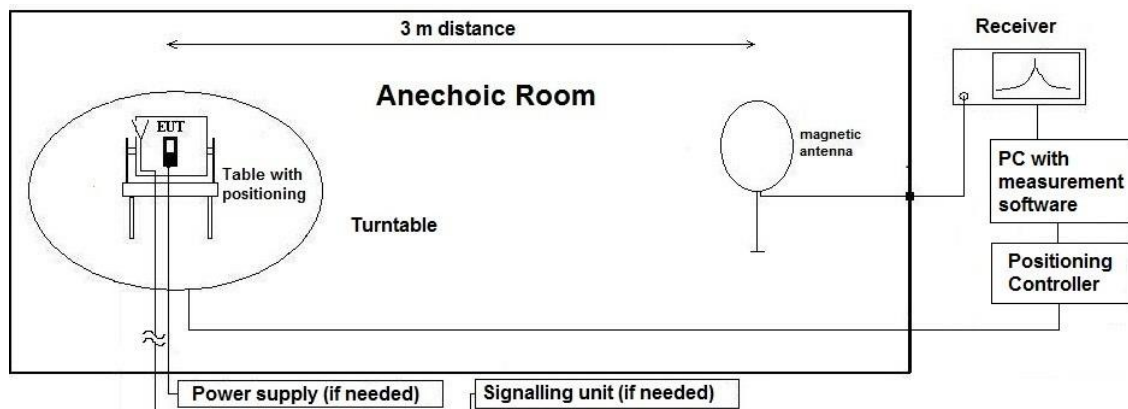

Testing method:

The measurement is made according to relevant reference clauses:
(See *Tables Summary of Test Results* and *Summary of Test Methods* on page 5)

Exploratory, preliminary measurements

The EUT and its associated accessories are placed on a non-conductive position manipulator (tipping device) of 0.8 m height which is placed on the turntable. By rotating the turntable (step 90°, range 0° to 360°) and the EUT itself either on 3-orthogonal axis (portable equipment) or 2-orthogonal axis (defined operational position of EUT), the emission spectrum was recorded.

The loop antenna was moved at least to 2-perpendicular axes (antenna vector in direction of EUT and parallel to EUT) in order to maximize the emissions. The results are documented in a diagram. Critical frequencies (low margin to limit) are saved within a data reduction table for further investigations. If various operating modes are supported, further investigations are made to find the worst-case. Also the interconnection cables and equipment position were varied in order to maximize the emissions.

Final measurement on critical frequencies

Based on the exploratory measurements, the most critical frequencies are re-measured by maintaining the EUT's worst-case operation mode, cable position, etc.

First a frequency zoom around the critical frequency is done to locate the frequency more precisely. After this step, for all identified critical frequencies, the maximum peak was determined.

Following parameters were varied: the turntable angle continuously in the range 0 to 360 degree, the EUT itself either over 3-orthogonal axis (not defined usage position) or 2-orthogonal axis (defined usage position).

On the determined worst-case position, a final measurement with necessary bandwidth and detector according standard has been carried out.

Formula:

$$E_C = E_R + AF + C_L + D_F - G_A$$

$$M = L_T - E_C$$

AF = Antenna factor

C_L = Cable loss

D_F = Distance correction factor (if used)

E_C = Electrical field – corrected value

E_R = Receiver reading

G_A = Gain of pre-amplifier (if used)

L_T = Limit

M = Margin

All units are dB-units, positive margin means value is below limit.

4.3.2 Measurement Location

Test site	120901 - SAC - Radiated Emission <1GHz
------------------	--

Correction factors due to reduced meas. distance (f< 30 MHz):

The used correction factors when the measurement distance is reduced compared to regulatory measurement distance, are calculated according Extrapolation formulas valid for EUT's with maximum dimension of 0.625xLambda. Formula 2+3+4 as presented in ANSI C63.10, Chapter 6.4.4 are used for the calculations of proper extrapolation factors

Frequency -Range	f [kHz/MHz]	Lambda [m]	Far-Field Point [m]	Distance Limit accord. 15.209 [m]	1st Condition (dmeas< Dnear-field)	2'te Condition (Limit distance bigger dnear-field)	Distance Correction accord. Formula
kHz	9.00E+03	33333.33	5305.17	300	fulfilled	not fulfilled	-80.00
	1.00E+04	30000.00	4774.65		fulfilled	not fulfilled	-80.00
	2.00E+04	15000.00	2387.33		fulfilled	not fulfilled	-80.00
	3.00E+04	10000.00	1591.55		fulfilled	not fulfilled	-80.00
	4.00E+04	7500.00	1193.66		fulfilled	not fulfilled	-80.00
	5.00E+04	6000.00	954.93		fulfilled	not fulfilled	-80.00
	6.00E+04	5000.00	795.78		fulfilled	not fulfilled	-80.00
	7.00E+04	4285.71	682.09		fulfilled	not fulfilled	-80.00
	8.00E+04	3750.00	596.83		fulfilled	not fulfilled	-80.00
	9.00E+04	3333.33	530.52		fulfilled	not fulfilled	-80.00
	1.00E+05	3000.00	477.47		fulfilled	not fulfilled	-80.00
	1.25E+05	2400.00	381.97		fulfilled	not fulfilled	-80.00
	2.00E+05	1500.00	238.73		fulfilled	fulfilled	-78.02
	3.00E+05	1000.00	159.16		fulfilled	fulfilled	-74.49
	4.00E+05	750.00	119.37		fulfilled	fulfilled	-72.00
	4.90E+05	612.24	97.44		fulfilled	fulfilled	-70.23
	5.00E+05	600.00	95.49		fulfilled	not fulfilled	-40.00
	6.00E+05	500.00	79.58		fulfilled	not fulfilled	-40.00
	7.00E+05	428.57	68.21		fulfilled	not fulfilled	-40.00
	8.00E+05	375.00	59.68		fulfilled	not fulfilled	-40.00
9.00E+05	333.33	53.05	fulfilled	not fulfilled	-40.00		
MHz	1.00	300.00	47.75	30	fulfilled	not fulfilled	-40.00
	1.59	188.50	30.00		fulfilled	not fulfilled	-40.00
	2.00	150.00	23.87		fulfilled	fulfilled	-38.02
	3.00	100.00	15.92		fulfilled	fulfilled	-34.49
	4.00	75.00	11.94		fulfilled	fulfilled	-32.00
	5.00	60.00	9.55		fulfilled	fulfilled	-30.06
	6.00	50.00	7.96		fulfilled	fulfilled	-28.47
	7.00	42.86	6.82		fulfilled	fulfilled	-27.13
	8.00	37.50	5.97		fulfilled	fulfilled	-25.97
	9.00	33.33	5.31		fulfilled	fulfilled	-24.95
	10.00	30.00	4.77		fulfilled	fulfilled	-24.04
	10.60	28.30	4.50		fulfilled	fulfilled	-23.53
	11.00	27.27	4.34		fulfilled	fulfilled	-23.21
	12.00	25.00	3.98		fulfilled	fulfilled	-22.45
	13.56	22.12	3.52		fulfilled	fulfilled	-21.39
	15.00	20.00	3.18		fulfilled	fulfilled	-20.51
	15.92	18.85	3.00		fulfilled	fulfilled	-20.00
	17.00	17.65	2.81		not fulfilled	fulfilled	-20.00
	18.00	16.67	2.65		not fulfilled	fulfilled	-20.00
	20.00	15.00	2.39		not fulfilled	fulfilled	-20.00
	21.00	14.29	2.27		not fulfilled	fulfilled	-20.00
	23.00	13.04	2.08		not fulfilled	fulfilled	-20.00
	25.00	12.00	1.91		not fulfilled	fulfilled	-20.00
	27.00	11.11	1.77		not fulfilled	fulfilled	-20.00
	29.00	10.34	1.65		not fulfilled	fulfilled	-20.00
	30.00	10.00	1.59		not fulfilled	fulfilled	-20.00

4.3.3 Limit

Radiated emissions limits, (3 meters)					
Frequency Range [MHz]	Limit [$\mu\text{V}/\text{m}$]	Limit [$\text{dB}\mu\text{V}/\text{m}$] *	Distance [m]	Detector	RBW [kHz]
0.009 – 0.09	2400 / f [kHz]	67.6 – 20Log(f) (kHz)	300	Pk & Avg	0.2
0.09 – 0.11	2400 / f [kHz]	67.6 – 20Log(f) (kHz)	300	Quasi peak	0.2
0.11 – 0.15	2400 / f [kHz]	67.6 – 20Log(f) (kHz)	300	Pk & Avg	0.2
0.15 – 0.49	2400 / f [kHz]	67.6 – 20Log(f) (kHz)	300	Pk & Avg	9
0.49 – 1.705	24000 / f [kHz]	87.6 – 20Log(f) (kHz)	30	Quasi peak	9
1.705 - 30	30	29.5	30	Quasi peak	9

*Remark: In Canada same limits apply, just unit reference is different

4.3.4 Result

Diagram	Channel	Mode	Maximum Level [$\text{dB}\mu\text{V}/\text{m}$] Frequency Range 0.009 – 30 MHz	Result
2.01a	80	1Mbps PWR4 Channel high EUT Standing	No remarkable peaks within 20 dB margin found	Passed
2.01b	80	1Mbps PWR4 Channel high EUT Laying	No remarkable peaks within 20 dB margin found	Passed

Remark: for more information and graphical plot see annex A1 **CETECOM_TR20-1-0017102T02a_A1**

4.4 Radiated field strength emissions 30 MHz – 1 GHz

4.4.1 Description of the general test setup and methodology, see below example:

Evaluating the emissions have to be done first by an exploratory emissions measurement and a final measurement for most critical frequencies. The tests are performed in a CISPR 16-1-4:2010 compliant semi anechoic room (SAR) and fully anechoic room (FAR) recognized by the regulatory commission. The measurement distance was set to 3 meter for frequencies up to 18 GHz and 2 meter above 18 GHz. A logarithmic periodic antenna is used for the frequency range 30 MHz to 1 GHz. Horn antennas are used for frequency range 1 GHz to 40 GHz. The EUT is aligned within 3 dB beam width of the measurement antenna with three orthogonal axis measurements on the EUT.

Schematic:

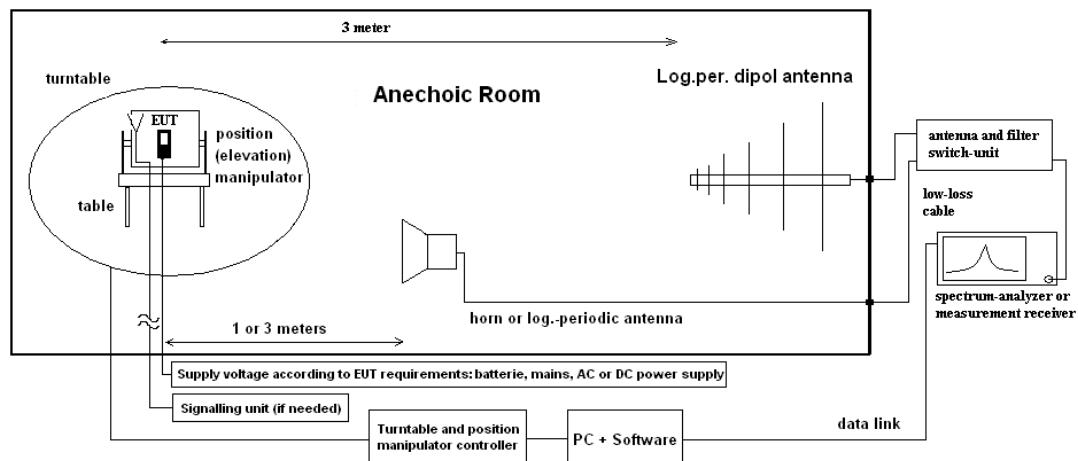

Testing method:

The measurement is made according to relevant reference clauses:

(See Tables *Summary of Test Results* and *Summary of Test Methods* on page 5)

Exploratory, preliminary measurements

The EUT and its associated accessories are placed on a non-conductive position manipulator (tipping device) of 0.8 m height which is placed on the turntable. By rotating the turntable (range 0° to 360°, step 90°) and the EUT itself either on 3-orthogonal axis (portable equipment) or 2-orthogonal axis (defined operational position of EUT) the emission spectrum and its characteristics was recorded with an EMI-receiver, broadband antenna and software.

Measurement antenna: horizontal and vertical, heights: 1,0 m and 1,82 m as worst-case determined by an exploratory emission measurements. The results are documented in a diagram. Critical frequencies (low margin to limit) are saved within a table for further investigations. If various operating modes are supported, further investigations are made to find the worst-case of them. Also the interconnection cables and equipment position were varied in order to maximize the emissions.

Final measurement on critical frequencies

Based on the exploratory measurements, the most critical frequencies are re-measured by maintaining the EUT's worst-case operation mode, cable position, etc. either on 10m OATS or 3m semi-anechoic room.

First a frequency zoom around the critical frequency is done to locate the frequency more precisely. After this step, for all identified critical frequencies, the maximum peak was determined.

Following parameters were varied: the turntable angle continuously in the range 0 to 360 degree, the EUT itself either over 3-orthogonal axis (not defined usage position) or 2-orthogonal axis (defined usage position). The measurement antenna height between 1 m and 4 m.

On the determined worst-case position, a final measurement with necessary bandwidth and detector according standard has been carried out

Formula:

$$E_C = E_R + AF + C_L + D_F - G_A \quad (1)$$

$$M = L_T - E_C \quad (2)$$

- AF = Antenna factor
- C_L = Cable loss
- D_F = Distance correction factor (if used)
- E_C = Electrical field – corrected value
- E_R = Receiver reading
- G_A = Gain of pre-amplifier (if used)
- L_T = Limit
- M = Margin

All units are dB-units, positive margin means value is below limit.

4.4.2 Measurement Location

Test site	120901 - SAC - Radiated Emission <1GHz
-----------	--

4.4.3 Limit

Radiated emissions limits, (3 meters)				
Frequency Range [MHz]	Limit [µV/m]	Limit [dBµV/m]	Detector	RBW / VBW [kHz]
30 - 88	100	40.0	Quasi peak	100 / 300
88 - 216	150	43.5	Quasi peak	100 / 300
216 - 960	200	46.0	Quasi peak	100 / 300
960 - 1000	500	54.0	Quasi peak	100 / 300

4.4.4 Result

Diagram	Channel	Mode	Maximum Level [dBµV/m] Frequency Range 30 – 1000 MHz	Result
3.01a	High	1MBps PWR4 Channel high EUT Standing	No remarkable peaks within 20 dB margin found	Passed
3.01b	High	1MBps PWR4 Channel high EUT Laying	No remarkable peaks within 20 dB margin found	Passed

Remark: for more information and graphical plot see annex A1 **CETECOM_TR20-1-0017102T02a_A1**

4.5 Radiated field strength emissions above 1 GHz

4.5.1 Description of the general test setup and methodology, see below example:

Evaluating the emissions have to be done first by an exploratory emissions measurement and a final measurement for most critical frequencies. The tests are performed in a CISPR 18-1-4:2010 compliant fully anechoic room (FAR) recognized by the regulatory commission. The measurement distance was set to 3 meter for frequencies up to 18 GHz and 2 meter above 18 GHz. A logarithmic periodic antenna is used for the frequency range 30 MHz to 1 GHz. Horn antennas are used for frequency range 1 GHz to 40 GHz. The EUT is aligned within 3 dB beam width of the measurement antenna with three orthogonal axis measurements on the EUT.

Schematic:

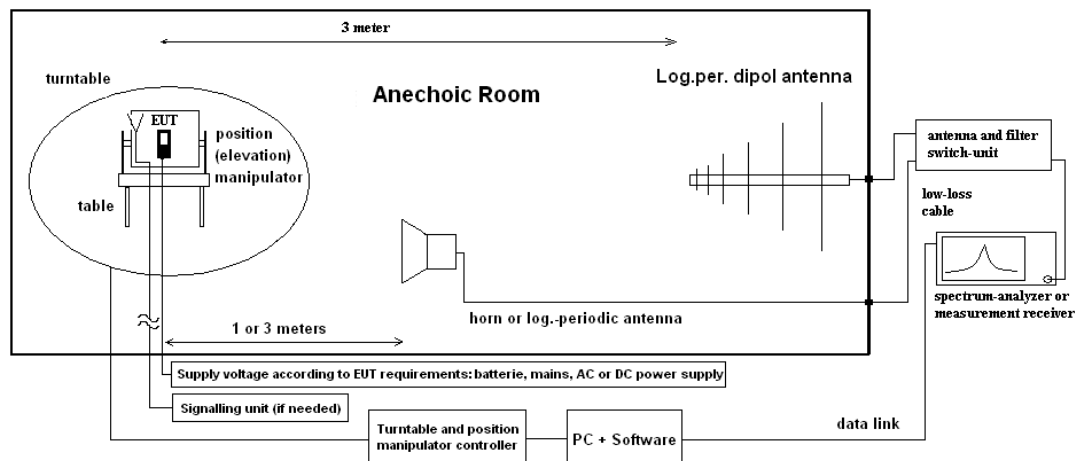

Testing method:

The measurement is made according to relevant reference clauses:
(See Tables *Summary of Test Results* and *Summary of Test Methods* on page 5)

Exploratory, preliminary measurements

The EUT and its associated accessories are placed on a non-conductive position manipulator (tipping device) of 1.55 m height which is placed on the turntable. By rotating the turntable (range 0° to 360°, step 15°) and the EUT itself either on 3-orthogonal axis (portable equipment) or 2-orthogonal axis (defined operational position of EUT) the emission spectrum and its characteristics was recorded with an EMI-receiver, broadband antenna and software.

The measurements are performed in horizontal and vertical polarization of the measurement antennas. The results are documented in a diagram. Critical frequencies (low margin to limit) are saved within a table for further investigations. If various operating modes are supported, further investigations are made to find the worst-case of them. Also the interconnection cables and equipment position were varied in order to maximize the emissions.

Final measurement on critical frequencies

Based on the exploratory measurements, the most critical frequencies are re-measured by maintaining the EUT's worst-case operation mode, cable position, etc.

First a frequency zoom around the critical frequency is done to locate the frequency more precisely. After this step, for all identified critical frequencies, the maximum peak was determined.

Following parameters were varied: the turntable angle continuously in the range 0 to 360 degree, the EUT itself over 3-orthogonal axis and the height for EUT with large dimensions or three axis scan for portable/small equipment.

On the determined worst-case position, a final measurement with necessary bandwidth and detector according standard has been carried out.

Formula:

$$E_C = E_R + A_F + C_L + D_F - G_A \quad (1)$$

$$M = L_T - E_C \quad (2)$$

E_C = Electrical field – corrected value

E_R = Receiver reading

M = Margin

L_T = Limit

A_F = Antenna factor

C_L = Cable loss

D_F = Distance correction factor (if used)

G_A = Gain of pre-amplifier (if used)

All units are dB-units, positive margin means value is below limit.

4.5.2 Measurement Location

Test site 1 – 18 GHz	120904 - FAC1 - Radiated Emissions
Test site 18 – 26.5 GHz	120904 - FAC1 - Radiated Emissions

4.5.3 Limit

Radiated emissions limits, (3 meters)				
Frequency Range [MHz]	Limit [μ V/m]	Limit [dB μ V/m]	Detector	RBW / VBW [kHz]
Above 1000	500	54	Average	1000 / 3000
Above 1000	5000	74	Peak	1000 / 3000

4.5.4 Result

Diagram	Channel	Mode	Maximum Level [dB μ V/m] Frequency Range 1 – 18 GHz	Result
4.01a	High	1Mbps PWR4 Channel high	47.67@ 7440 MHz *)	Passed

Remark: for more information and graphical plot see annex A1 **CETECOM_TR20-1-0017102T02a_A1**

*) including Duty cycle correction Factor

Diagram	Channel	Mode	Maximum Level [dB μ V/m] Frequency Range 18 – 26.5 GHz	Result
4.01b	High	1Mbps PWR4 Channel high	47.88 @25053.090 MHz **)	Passed

Remark: for more information and graphical plot see annex A1 **CETECOM_TR20-1-0017102T02a_A1**

**) no correction necessary, Noise level

4.6 Radiated Band-Edge emissions

4.6.1 Description of the general test setup and methodology, see below example:

Schematic:

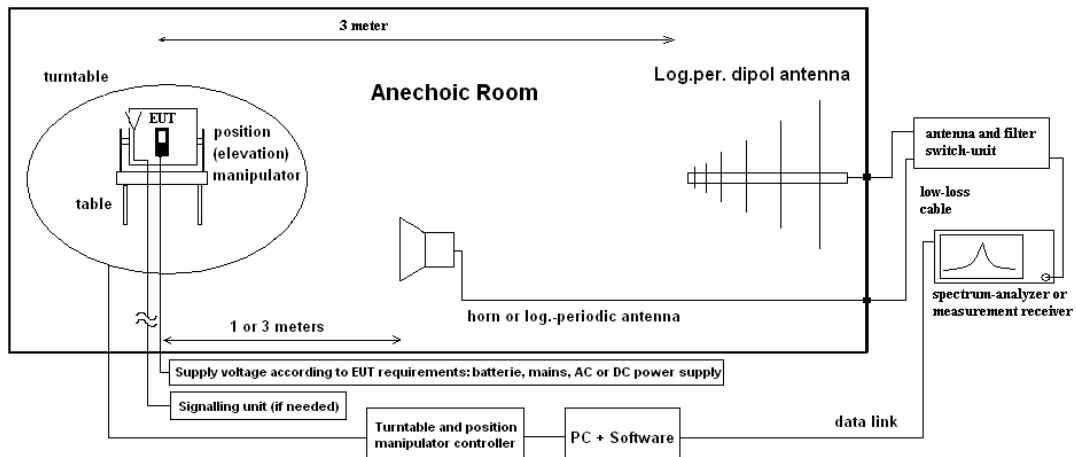

Testing method:

The measurement is made according to relevant reference clauses:
(See Tables *Summary of Test Results* and *Summary of Test Methods* on page 5)

For uncritical results where a measurement resolution bandwidth of 1MHz can clearly show the compliance without influencing the results, a field strength measurement was performed to show compliance.

For critical results a Marker-Delta marker method was used for showing compliance to restricted bands.
The method consists of three independent steps:

1. Step: Prior to the measurement the fundamental radiated In-Band field strength was performed. The determined value is used as reference value.
2. Step: Second step consist of finding the relative attenuation between the fundamental emission and the maximum local out-of-band emission (within 2 MHz range around the band edge either on the band-edge directly or some modulation product if the level is greater than that on the band-edge) when measured with lower resolution bandwidth.
3. .Step: The delta value recorded in step 2 will be subtracted from value recorded in step 1, thus giving the required field strength at the band-edge. This value must fulfil the requirements for radiated spurious emissions in restricted bands in FCC §15.205 with the general limits of FCC §15.209

The EUT was instructed to send with maximum power (if adjustable) according to applicants instructions.

4.6.2 Measurement Location

Test site	120904 - FAC1 - Radiated Emissions
-----------	------------------------------------

4.6.3 Limit

Frequency Range [MHz]	Pk Limit [dBc]	Avg Limit [dBc]	Avg Limit [dB μ V/m]	Pk Limit [dB μ V/m]	Detector	RBW / VBW [kHz]
Below 2390	-	-	54	74	Average / Peak	100 / 300
Above 2483.5	-	-	54	74	Average / Peak	1000 / 3000
2390 - 2400	-20	-	-	-	Peak	100 / 300
2390 - 2400	-	-30	-	-	Average	100 / 300

4.6.4 Result

Non-restricted bands near-by

Diagram	Channel	Mode	Peak [dBc]	Average [dBc]	Result
9.01	Low	1MBps PWR4 Channel low	34.80	39.17	PASSED

Remark: for more information and graphical plot see annex A1 [CETECOM_TR20-1-0017102T02a_A1](#)

Restricted bands near-by

Diagram	Channel	Mode	Peak [dB μ V/m]	Average *1) [dB μ V/m]	Result
9.02	High	1MBps PWR4 Channel high	57.55	46.89	PASSED

Remark1: Average value corrected with Duty Cycle - Factor

Remark2: for more information and graphical plot see annex A1 [CETECOM_TR20-1-0017102T02a_A1](#)

4.7 Results from external laboratory

None

-

4.8 Opinions and interpretations

None

-

4.9 List of abbreviations

None

-

5 Equipment lists

ID	Description	Manufacturer	SerNo	Cal due date
	120901 - SAC - Radiated Emission <1GHz			2025-Jul-21
20574	Biconilog Hybrid Antenna BTA-L	Frankonia GmbH	980026L	2022-May-03
20487	CETECOM Semi Anechoic Chamber < 1GHz	ETS-Lindgren GmbH	-	2025-Jul-15
20620	EMI Test Receiver ESU26	Rohde & Schwarz Messgerätebau GmbH	100362	2021-May-13
20482	filter matrix Filter matrix SAR 1	CETECOM GmbH	-	
25038	Loop Antenna HFH2-Z2	Rohde & Schwarz Messgerätebau GmbH	879824/13	2022-Apr-07
20885	Power Supply EA3632A	Agilent Technologies Deutschland GmbH	75305850	
	120904 - FAC1 - Radiated Emissions			
20341	Digital Multimeter Fluke 112	Fluke Deutschland GmbH	81650455	2022-May-25
20720	EMC32 [FAC]	Rohde & Schwarz Messgerätebau GmbH	V10.xx	
20489	EMI Test Receiver ESU40	Rohde & Schwarz Messgerätebau GmbH	1000-30	2021-May-13
20254	High Pass Filter 5HC 2600/12750-1.5KK (GSM1800/1900/DECT)	Trilithic	23042	
20868	High Pass Filter AFH-07000	AtlanTecRF	16071300004	
20291	High Pass Filter WHJ 2200-4EE (GSM 850/900)	Wainwright Instruments GmbH	14	
20020	Horn Antenna 3115 (Subst 1)	EMCO Elektronik GmbH	9107-3699	2021-Jul-19
20302	Horn Antenna BBHA9170 (Meas 1)	Schwarzbeck Mess-Elektronik OHG	155	2023-Apr-15
20549	Log.Per-Antenna HL025	Rohde & Schwarz Messgerätebau GmbH	1000060	2021-Jul-31
20700	PC ctc662012 [FAC]	Dell Inc.		
20611	Power Supply E3632A	Agilent Technologies Deutschland GmbH	KR 75305854	
20338	Pre-Amplifier 100MHz - 26GHz JS4-00102600-38-5P	Miteq Inc.	838697	

ID	Description	Manufacturer	SerNo	Cal due date
20484	Pre-Amplifier 2,5GHz - 18GHz AMF-5D-02501800-25-10P	Miteq Inc.	1244554	
20287	Pre-Amplifier 25MHz - 4GHz AMF-2D-100M4G-35-10P	Miteq Inc.	379418	
20690	Spectrum Analyzer FSU	Rohde & Schwarz Messgerätebau GmbH	100302/026	2021-May-23
20439	UltraLog-Antenna HL 562	Rohde & Schwarz Messgerätebau GmbH	100248	2023-Mar-10
120910 - Radio Laboratory 1 (TS 8997)				
20904	Climatic Chamber ClimeEvent C/1000/70a/5	Weiss Umwelttechnik GmbH	58226223240010	2021-May-09
20871	NRP-Z81	Rohde & Schwarz Messgerätebau GmbH	104631	2021-Mar-24
20872	NRX Power Meter	Rohde & Schwarz Messgerätebau GmbH	101831	2022-Jan-28
20805	Open Switch and control Platform OSP B157WX 40GHz 8Port Switch	Rohde & Schwarz Messgerätebau GmbH	101264	2021-May-13
20691	Open Switch and control Platform OSP120	Rohde & Schwarz Messgerätebau GmbH	101056	2021-May-13
20866	Signal Analyzer FSV3030	Rohde & Schwarz Messgerätebau GmbH	101247	2021-Sep-09
20687	Signal Generator SMF 100A	Rohde & Schwarz Messgerätebau GmbH	102073	2021-Feb-07
20559	Vector Signal Generator SMU200A	Rohde & Schwarz Messgerätebau GmbH	103736	2021-May-22
20873	WTS-80 Schirmbox	CETECOM GmbH	P3101	

6 Measurement Uncertainty valid for conducted/radiated measurements

The reported uncertainties are calculated based on the standard uncertainty multiplied with the appropriate coverage factor k , such that a confidence level of approximately 95% is achieved. For uncertainty determination, each component used in the concrete measurement set-up was taken in account and its contribution to the overall uncertainty according its statistical distribution calculated.

RF-Measurement	Reference	Frequency range	Calculated uncertainty based on a confidence level of 95%						Remarks
Conducted emissions (U_{CISPR})	-	9 kHz - 150 kHz	4.0 dB						-
		150 kHz - 30 MHz	3.6 dB						
Power Output radiated	-	30 MHz - 4 GHz	3.17 dB						Substitution method
Power Output conducted	-	Set-up No.	Cel-C1	Cel-C2	BT1	W1	W2	--	-
		9 kHz - 12.75 GHz	N/A	0.60	0.7	0.25	N/A	--	
		12.75 GHz - 26.5 GHz	N/A	0.82	--	N/A	N/A	--	
Conducted emissions on RF-port	-	9 kHz - 2.8 GHz	0.70	N/A	0.70	N/A	0.69	--	N/A - not applicable
		2.8 GHz - 12.75 GHz	1.48	N/A	1.51	N/A	1.43	--	
		12.75 GHz - 18 GHz	1.81	N/A	1.83	N/A	1.77	--	
		18 GHz - 26.5 GHz	1.83	N/A	1.85	N/A	1.79	--	
Occupied bandwidth	-	9 kHz - 4 GHz	0.1272 ppm (Delta Marker)						Frequency error
			1.0 dB						Power
Emission bandwidth	-	9 kHz - 4 GHz	0.1272 ppm (Delta Marker)						Frequency error
			See above: 0.70 dB						Power
Frequency stability	-	9 kHz - 20 GHz	0.0636 ppm						-
Radiated emissions Enclosure	-	150 kHz - 30 MHz	5.01dB						Magnetic field strength
		30 MHz - 1 GHz	5.83 dB						Electrical Field strength
		1 GHz - 18 GHz	4.91 dB						
		18-26.5 GHz	5.06 dB						

7 Versions of test reports (change history)

Version	Applied changes	Date of release
--	Initial release	2021-Mar-16
--	--	--
--	--	--

End Of Test Report