

Global EMC Inc. Labs EMC & RF Test Report

As per

RSS 210 Issue 8:2010

&

FCC Part 15 Subpart C:2014

Unlicensed Intentional Radiators

on the

WEM01



Min Xie
Project Engineer
11 Gordon Collins Dr,
Gormley, ON, L0H 1G0 Canada
Ph: (905) 883-8189

Testing produced for



See Appendix A for full customer & EUT details.





Client	Ecobee Inc	
Product	WEM01	
Standard(s)	RSS 210 Issue 8:2010 / FCC Part 15 Subpart C 15:2014	

Table of Contents

Table of Contents	2
Report Scope	3
Summary	4
Test Results Summary	5
Justifications, Descriptions, or Deviations.....	6
Applicable Standards, Specifications and Methods.....	7
Sample calculation(s).....	8
Document Revision Status.....	8
Definitions and Acronyms	9
Testing Facility	10
Calibrations and Accreditations.....	10
Testing Environmental Conditions and Dates	11
Detailed Test Results Section	12
6dB Bandwidth of Digitally Modulated Systems – 15.247	13
Maximum Peak Envelope Conducted Power - DM.....	27
Antenna Spurious Conducted Emissions (-20 dBc Requirement) – 15.247.....	31
Radiated Emissions – 15.247	44
Test Equipment List.....	92
Power Spectral Density – 15.247 DM	93
Maximum Permissible Exposure – 15.247	103
Power Line Conducted Emissions	104
Appendix A – EUT Summary.....	110
Appendix B – EUT and Test Setup Photographs.....	113

Client	Ecobee Inc	
Product	WEM01	
Standard(s)	RSS 210 Issue 8:2010 / FCC Part 15 Subpart C 15:2014	

Report Scope

This report addresses the EMC verification testing and test results of Ecobee Inc's WEM01, herein referred to as EUT (Equipment Under Test) performed at Global EMC Labs.

The EUT was tested for compliance against the following standards:

RSS 210 Issue 8:2010
FCC Part 15 Subpart C 15:2014

Test procedures, results, justifications, and engineering considerations, if any, follow later in this report.

The results contained in this report relate only to the item(s) tested.

This report does not imply product endorsement by A2LA or any other accreditation agency, any government, or Global EMC Inc.

Opinions/interpretations expressed in this report, if any, are outside the scope of Global EMC Inc accreditation. Any opinions expressed do not necessarily reflect the opinions of Global EMC Inc, unless otherwise stated.

Client	Ecobee Inc	
Product	WEM01	
Standard(s)	RSS 210 Issue 8:2010 / FCC Part 15 Subpart C 15:2014	

Summary

The results contained in this report relate only to the item(s) tested.

EUT FCC Certification #, FCC ID:	WR9WEM01
EUT Industry Canada Certification #, IC:	7981A-WEM01
EUT Passed all tests performed.	Yes (see test results summary)
Tests conducted by	Min Xie

Client	Ecobee Inc	
Product	WEM01	
Standard(s)	RSS 210 Issue 8:2010 / FCC Part 15 Subpart C 15:2014	

Test Results Summary

Standard/Method	Description	Class/Limit	Result
FCC 15.203	Antenna Requirement	Unique	Pass See Justification
FCC 15.205 RSS 210 (Table 1)	Restricted Bands for intentional operation	QuasiPeak Average	Pass
FCC 15.207	Power line conducted emissions	QuasiPeak Average	Pass
FCC 15.209 RSS-210 (Table 2)	Spurious Radiated emissions	QuasiPeak Average	Pass
FCC 15.247(a)2 RSS-210 A8.2(a)	6 dB Bandwidth	> 500 kHz	Pass
FCC 15.247(b)2 RSS-210 A8.4(4)	Max output power	< 1 Watt	Pass
FCC 15.247(b)(4) RSS-210 A8.4(5)	Antenna Gain	< 6 dBi	Pass See Justifications
FCC 15.247(d) RSS-210 A8.5	Antenna conducted spurious	< 20 dBc	Pass
FCC 15.247(e) RSS-210 A8.2(b)	Spectral Density	< 8 dBm (3 kHz BW)	Pass
FCC 15.247(i) IC Safety code 6	Maximum Permissible Exposure	> 20 cm separation.	Pass See justification and calculations
Overall Result			PASS

All tests were performed by Min Xie.

If the product as tested or otherwise complies with the specification, the EUT is deemed to comply with the requirement and is deemed a 'PASS' grade. If not 'FAIL' grade will be issued. Note that 'PASS' / 'FAIL' grade is independent of any measurement uncertainties. A 'PASS' / 'FAIL' grade within measurement uncertainty is marked with a '*'.

Client	Ecobee Inc	
Product	WEM01	
Standard(s)	RSS 210 Issue 8:2010 / FCC Part 15 Subpart C 15:2014	

Justifications, Descriptions, or Deviations

The following justifications for tests not performed or deviations from the above listed specifications apply:

For the Antenna requirement specified in FCC 15.203 (RSS 210 section 5.5), the unit uses a permanently connected SMD antenna (2.1 dBi gain – Antenova Rufa 2.4 GHz SMD Antenna) which is less than 6 dBi gain.

For the Restricted Bands of operation, the EUT is designed to only operate between 2400 – 2483.5 MHz band.

For maximum permissible exposure, this device operates at less than 1 Watt at 2400 – 2483.5 MHz and is designed to operate greater than 20 cm from any personnel during normal operation. No testing is required, however worst case calculated exposure compliance follows later in this report.

The EUT is not a hybrid system and FCC 15.247 (f) does not apply to it. However the 15.247 (d) requirement of power density were met and are detailed later in this test report.

For the scope of this test report the EUT was mounted in three orthogonal axes to maximize emissions. Worst case results are presented.

For antenna port conducted emissions, a thin coax pigtail with SMA connection was soldered at the antenna input and the chip antenna was removed.

Client	Ecobee Inc	
Product	WEM01	
Standard(s)	RSS 210 Issue 8:2010 / FCC Part 15 Subpart C 15:2014	

Applicable Standards, Specifications and Methods

- ANSI C63.4:2009 - Methods of Measurement of Radio-Noise Emissions from Low-Voltage Electrical and Electronic Equipment in the Range of 9 kHz to 40 GHz
- ANSI C63.10:2009 - American national standard for testing unlicensed wireless devices
- CFR 47 FCC 15 - Code of Federal Regulations – Radio Frequency Devices
- CISPR 22:2008 - Information technology equipment – Radio disturbance characteristics – Limits and methods of measurement
- FCC KDB 558074:June 5, 2014
- FCC KDB 558074 Digital Transmission Systems, measurements and procedures
- ICES-003:2012 - Digital Apparatus - Spectrum Management and Telecommunications Policy Interference-Causing Equipment Standard
- ISO 17025:2005 - General Requirements for the competence of testing and calibration laboratories
- RSS-GEN General Requirements and Information for the Certification of Radio Apparatus
- RSS 210:2010 - Issue 8: Spectrum Management and Telecommunications Policy. Radio Standards Specification Low Power License-Exempt Radiocommunication Devices

Client	Ecobee Inc	
Product	WEM01	
Standard(s)	RSS 210 Issue 8:2010 / FCC Part 15 Subpart C 15:2014	

Sample calculation(s)

Margin = limit – (received signal + antenna factor + cable loss – pre-amp gain)

Margin = 50.5dBuV/m – (50dBuV + 10dB + 2.5dB – 20dB)

Margin = 8.5 dB

Document Revision Status

Revision 1 - October 22, 2014
Initial release

Client	Ecobee Inc	
Product	WEM01	
Standard(s)	RSS 210 Issue 8:2010 / FCC Part 15 Subpart C 15:2014	

Definitions and Acronyms

The following definitions and acronyms are applicable in this report.
See also ANSI C63.14.

AE – Auxillary Equipment.

BW – Bandwidth. Unless otherwise stated, this is refers to the 6 dB bandwidth.

EMC – Electro-Magnetic Compatibility

EMI – Electro-Magnetic Immunity

EUT – Equipment Under Test

ITE – Information Technology Equipment with a primary function(s) of entry, storage, display, retrieval, transmission, processing, switching, or control, of data.

LISN – Line impedance stabilization network

NCR – No Calibration Required

RF – Radio Frequency

Client	Ecobee Inc	
Product	WEM01	
Standard(s)	RSS 210 Issue 8:2010 / FCC Part 15 Subpart C 15:2014	

Testing Facility

Testing for EMC on the EUT was carried out at Global EMC labs in Toronto, Ontario, Canada. The testing lab consists of a 3m semi-anechoic chamber calibrated to be able to allow measurements on an EUT with a maximum width or length of up to 2m and height up to 3m. The chamber is equipped with a turn table that is capable of testing devices up to 3300lb in weight. This facility is capable of testing products that are rated for 120 Vac and 240Vac single phase, or 208 Vac 3 phase input. DC capability is also available. The chamber is equipped with an antenna mast that controls polarization and height from the control room adjoining the shielded chamber. Radiated emissions measurements are performed using a Bilog, and Horn antenna where applicable. Conducted emissions, unless otherwise stated, are performed using a LISN.

Calibrations and Accreditations

The 3m semi-anechoic chamber is registered with Federal Communications Commission (FCC, 377448), Industry Canada (IC, 6844A-3) and VCCI (R-4023, G-506, T-1246, and C-4498). This semi-anechoic chamber complies with the requirements of EN55016-2-3:2006, section 7.5 and the site attenuation requirements of EN55016-1-4. This chamber was additionally calibrated for Normalized Site Attenuation (NSA) using test procedures outlined in ANSI C63.4 “Methods of Measurement of Radio-Noise Emissions from Low-Voltage Electrical and Electronic Equipment in the Range of 9 kHz to 40 GHz”. The chamber is lined with ferrite tiles and absorption cones to minimize any undesired reflections. The NSA data is kept on file at Global EMC. For radiated susceptibility testing, a 16 point field calibration has been performed on the chamber. The field uniformity data is kept on file at Global EMC. Global EMC Inc is accredited to ISO 17025 by A2LA with Testing Certificate #2555.01. The laboratories current scope of accreditation listing can be found as listed on the A2LA website. All measuring equipment is calibrated on an annual or bi-annual basis as listed for each respective test.

Client	Ecobee Inc	
Product	WEM01	
Standard(s)	RSS 210 Issue 8:2010 / FCC Part 15 Subpart C 15:2014	

Testing Environmental Conditions and Dates

Following were the environmental conditions in the facility during time of testing –

Date	Test	Init.	Temperature (°C)	Humidity (%)	Pressure (kPa)
2014/10/2 to 22	All	MX	20-24°C	39 - 50%	96 -102kPa

Client	Ecobee Inc	
Product	WEM01	
Standard(s)	RSS 210 Issue 8:2010 / FCC Part 15 Subpart C 15:2014	

Detailed Test Results Section

Client	Ecobee Inc	
Product	WEM01	
Standard(s)	RSS 210 Issue 8:2010 / FCC Part 15 Subpart C 15:2014	

6dB Bandwidth of Digitally Modulated Systems – 15.247

Purpose

The purpose of this test is to ensure that the bandwidth occupied exceeds a stated minimum. This helps ensure the utilization of the frequency allocation is sufficiently wide. This also helps prevent corruption of data by ensuring adequate data separation to distinguish the reception of the intended information.

Limits and Methods

The Limit is as specified in FCC Part 15 and RSS 210.

Systems using digital modulation techniques may operate in the 902 - 928 MHz, 2400 - 2483.5 MHz, and 5725 - 5850 MHz bands. The minimum 6 dB bandwidth shall be at least 500 kHz. This should be measured with a 100 kHz RBW and a 300 kHz VBW.

The method is given in Section 8.1 of FCC KDB 558074: June 5 2014

Results

The EUT passed. The minimum measured 6 dB BW was:

B-Mode	10.2 MHz
G-Mode	16.7 MHz
N-Mode	16.7 MHz

And the minimum measured 20 dB BW was:

B-Mode	16.1 MHz
G-Mode	18.8 MHz
N-Mode	19.6 MHz

Client	Ecobee Inc	
Product	WEM01	
Standard(s)	RSS 210 Issue 8:2010 / FCC Part 15 Subpart C 15:2014	

Graph(s)

The graphs showed below shows the OBW during the operation of the device. This is measured by a max hold on the spectrum analyzer and the highest resolution bandwidth that is sufficiently low to exhibit the 6 dB bandwidth of a channel during operation of the EUT. This measurement is a peak measurement. Max hold is performed for a duration of not less than 1 minute.

B-Protocol, Hi Channel

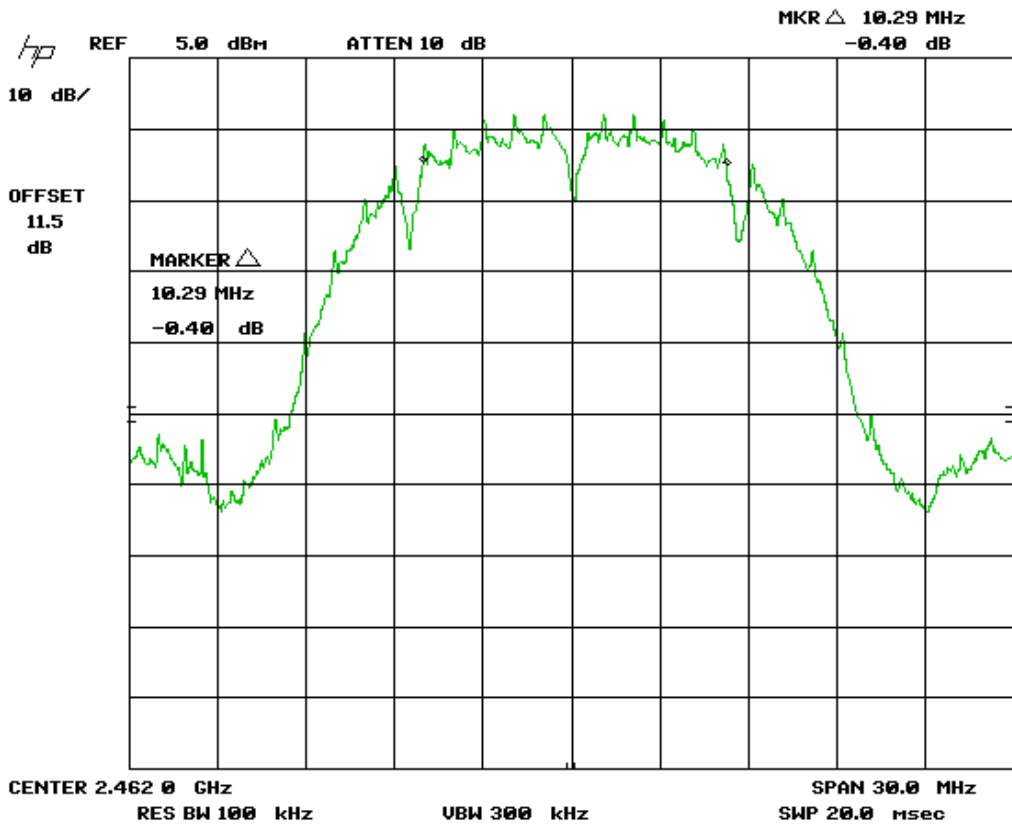

6 dB BW = 10.29 MHz
 20 dB BW = 16.29 MHz

Client	Ecobee Inc	
Product	WEM01	
Standard(s)	RSS 210 Issue 8:2010 / FCC Part 15 Subpart C 15:2014	

B-Protocol, Mid Channel

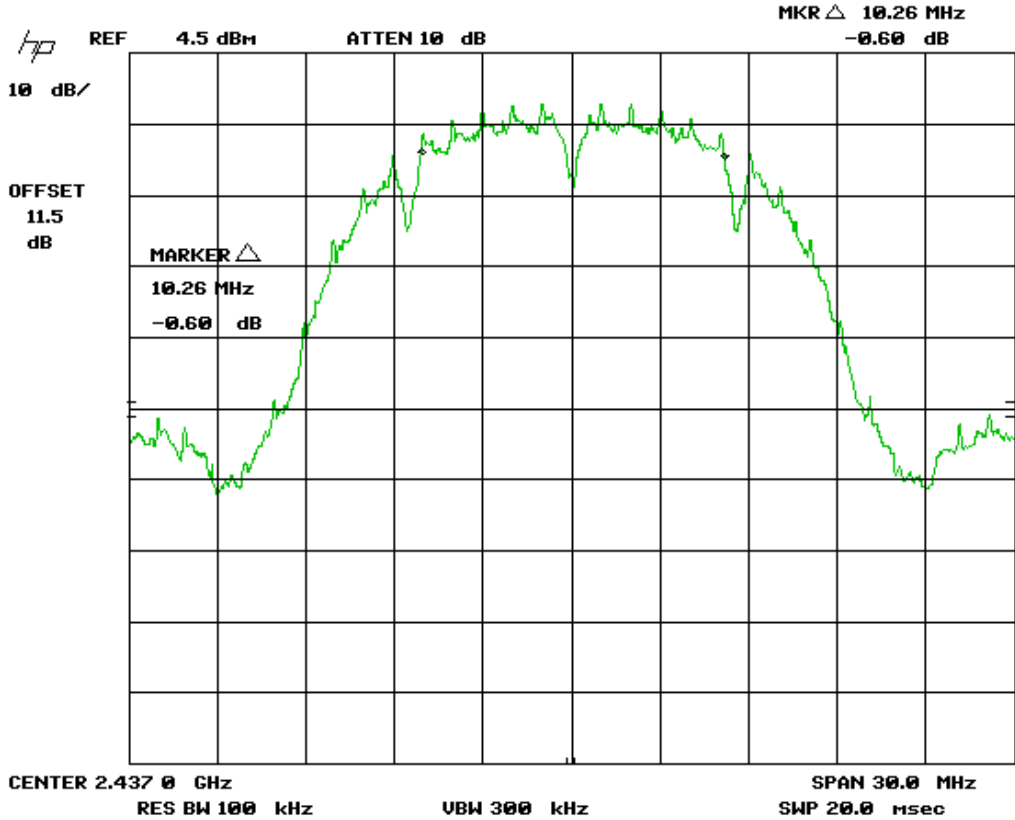

6 dB BW = 10.26 MHz
 20 dB BW = 16.29 MHz

Client	Ecobee Inc	
Product	WEM01	
Standard(s)	RSS 210 Issue 8:2010 / FCC Part 15 Subpart C 15:2014	

B-Protocol, Low Channel

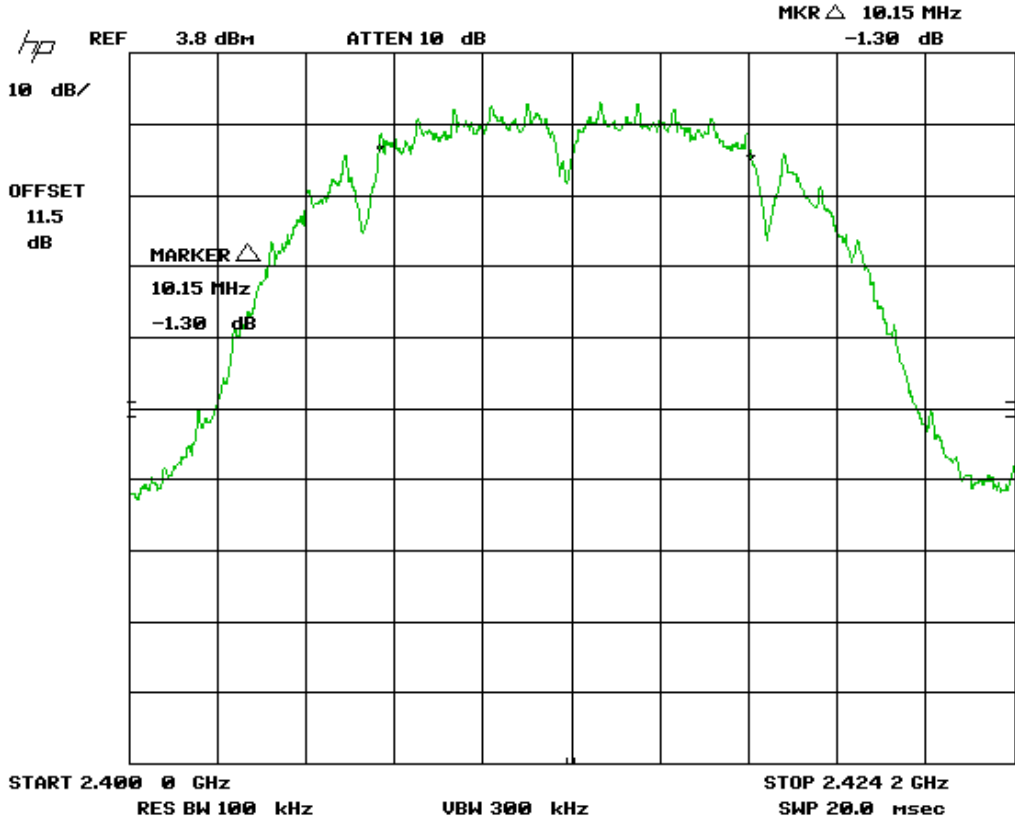

6 dB BW = 10.15 MHz

Client	Ecobee Inc	
Product	WEM01	
Standard(s)	RSS 210 Issue 8:2010 / FCC Part 15 Subpart C 15:2014	

B-Protocol, Low Channel

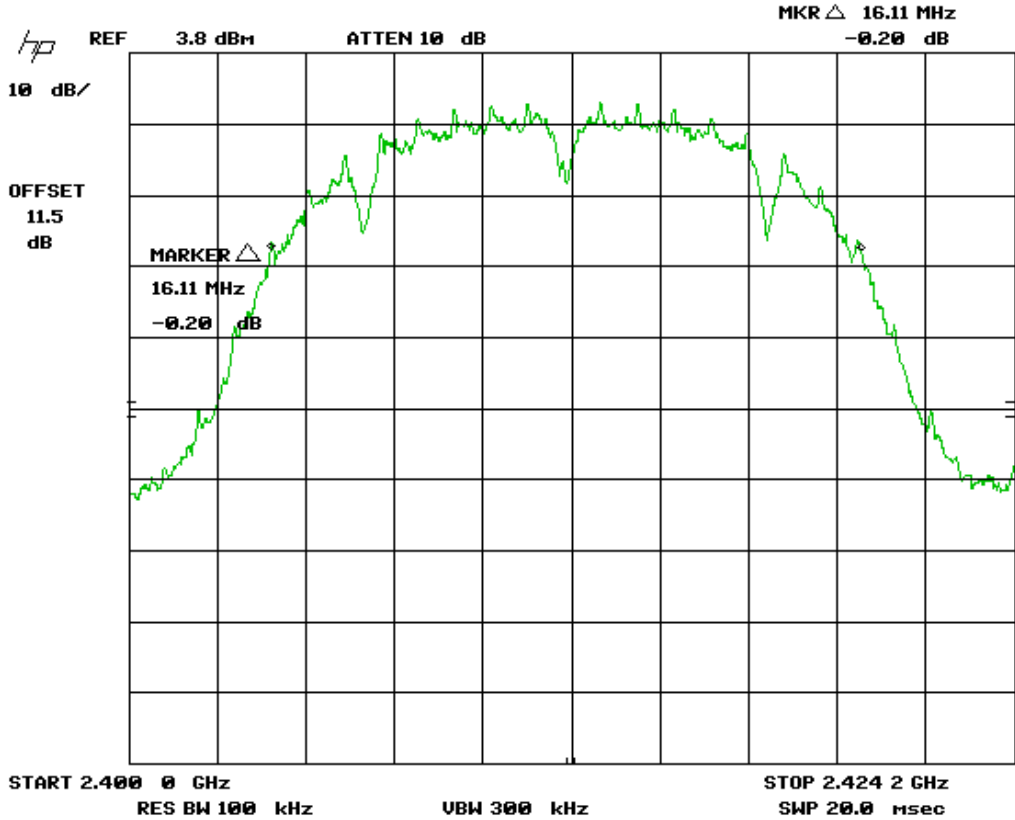

20 dB BW = 16.11 MHz

Client	Ecobee Inc	
Product	WEM01	
Standard(s)	RSS 210 Issue 8:2010 / FCC Part 15 Subpart C 15:2014	

G-Protocol, Hi Channel

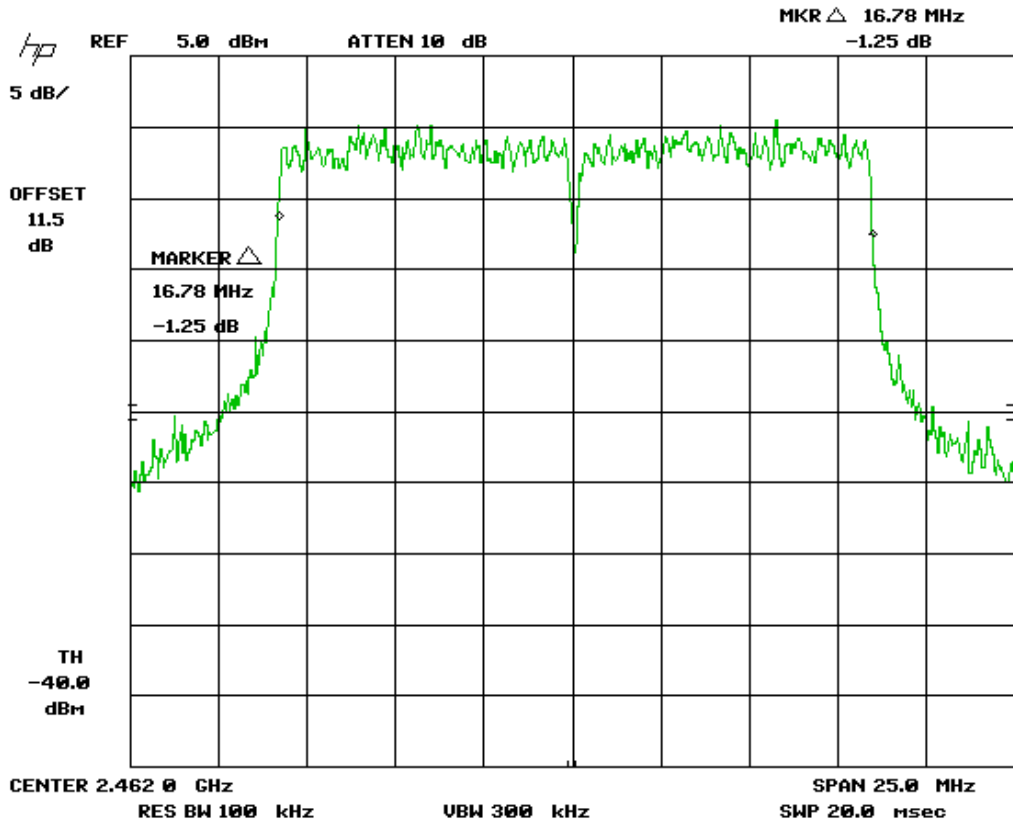

6 dB BW = 16.78 MHz
 20 dB BW = 19.60 MHz

Client	Ecobee Inc	
Product	WEM01	
Standard(s)	RSS 210 Issue 8:2010 / FCC Part 15 Subpart C 15:2014	

G-Protocol, Mid Channel

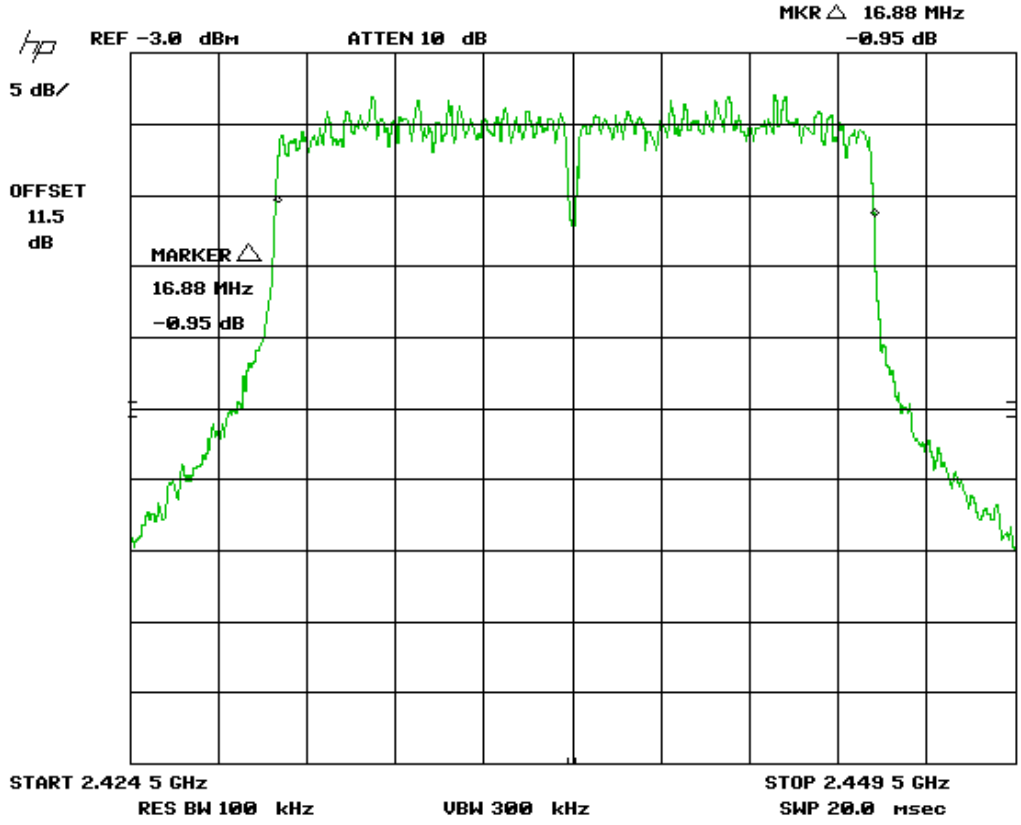

6 dB BW = 16.88 MHz

Client	Ecobee Inc	
Product	WEM01	
Standard(s)	RSS 210 Issue 8:2010 / FCC Part 15 Subpart C 15:2014	

G-Protocol, Mid Channel

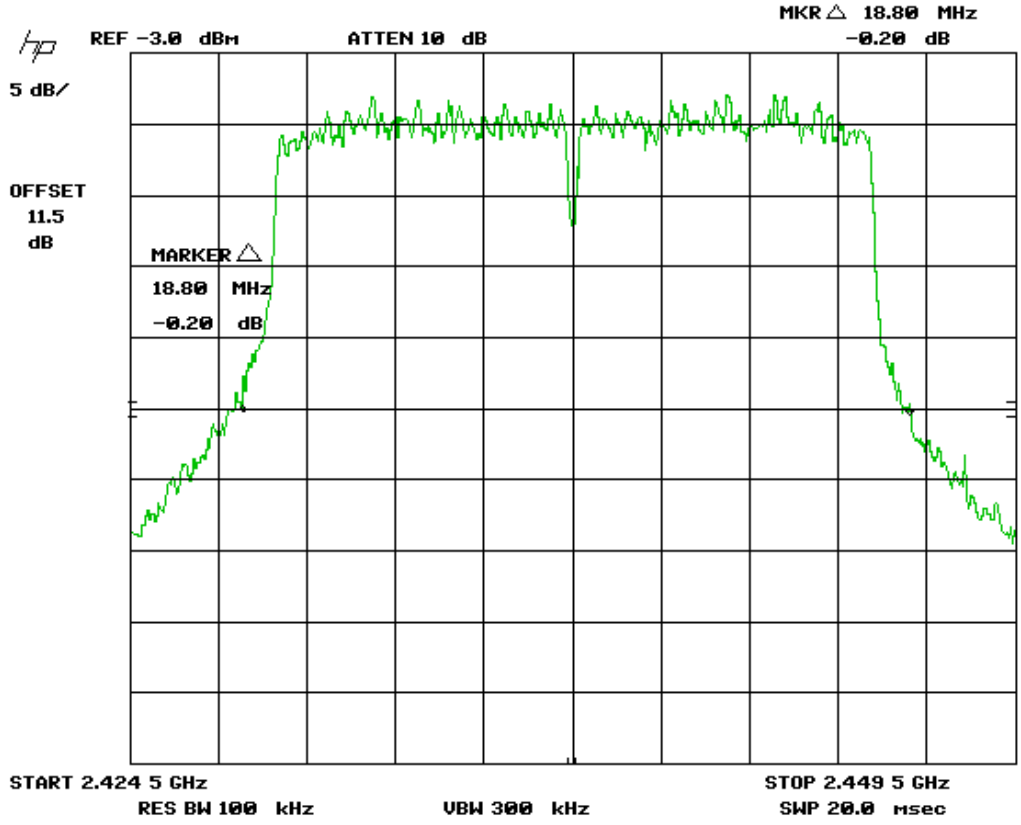

20 dB BW = 18.80 MHz

Client	Ecobee Inc	
Product	WEM01	
Standard(s)	RSS 210 Issue 8:2010 / FCC Part 15 Subpart C 15:2014	

G-Protocol, Low Channel

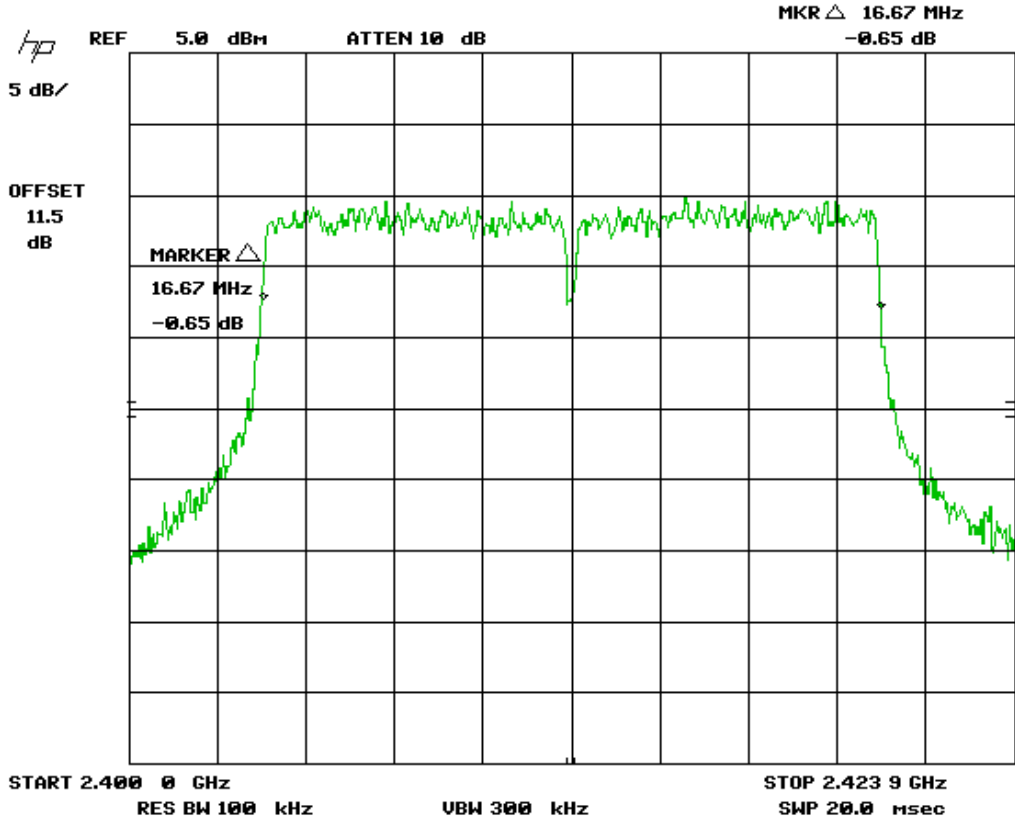

6 dB BW = 16.67 MHz
 20 dB BW = 19.88 MHz

Client	Ecobee Inc	
Product	WEM01	
Standard(s)	RSS 210 Issue 8:2010 / FCC Part 15 Subpart C 15:2014	

N-Protocol, Hi Channel

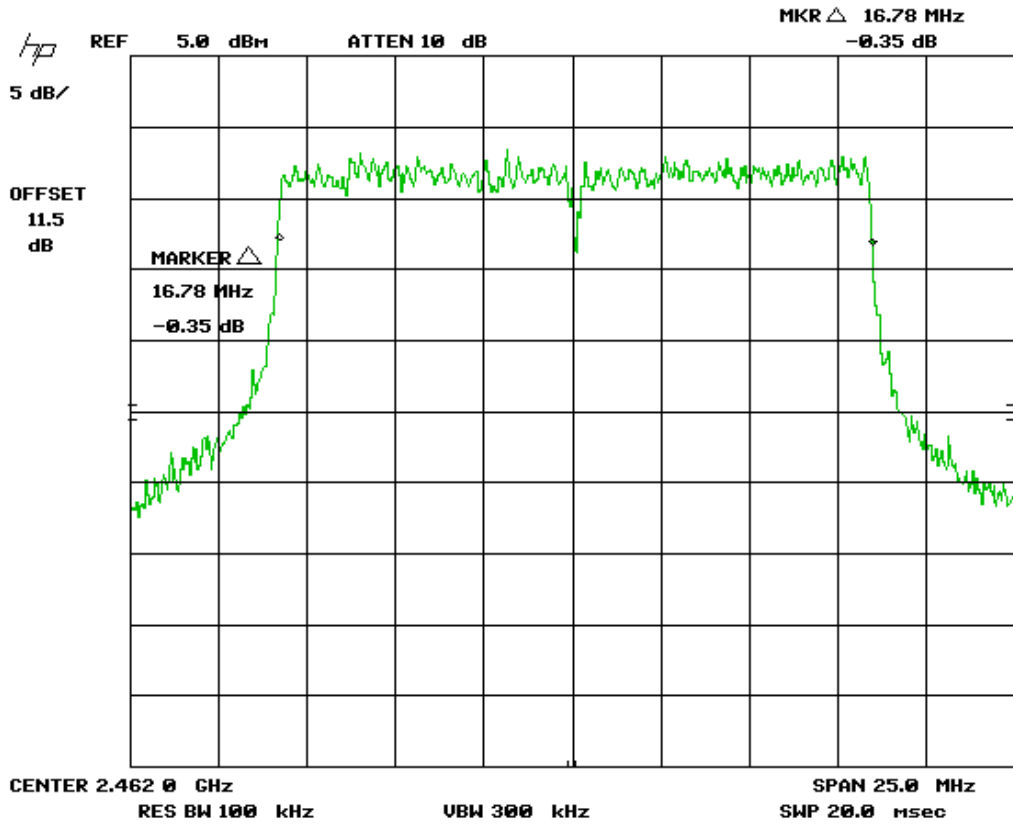

6 dB BW = 16.78 MHz
 20 dB BW = 19.68 MHz

Client	Ecobee Inc	
Product	WEM01	
Standard(s)	RSS 210 Issue 8:2010 / FCC Part 15 Subpart C 15:2014	

N-Protocol, Mid Channel

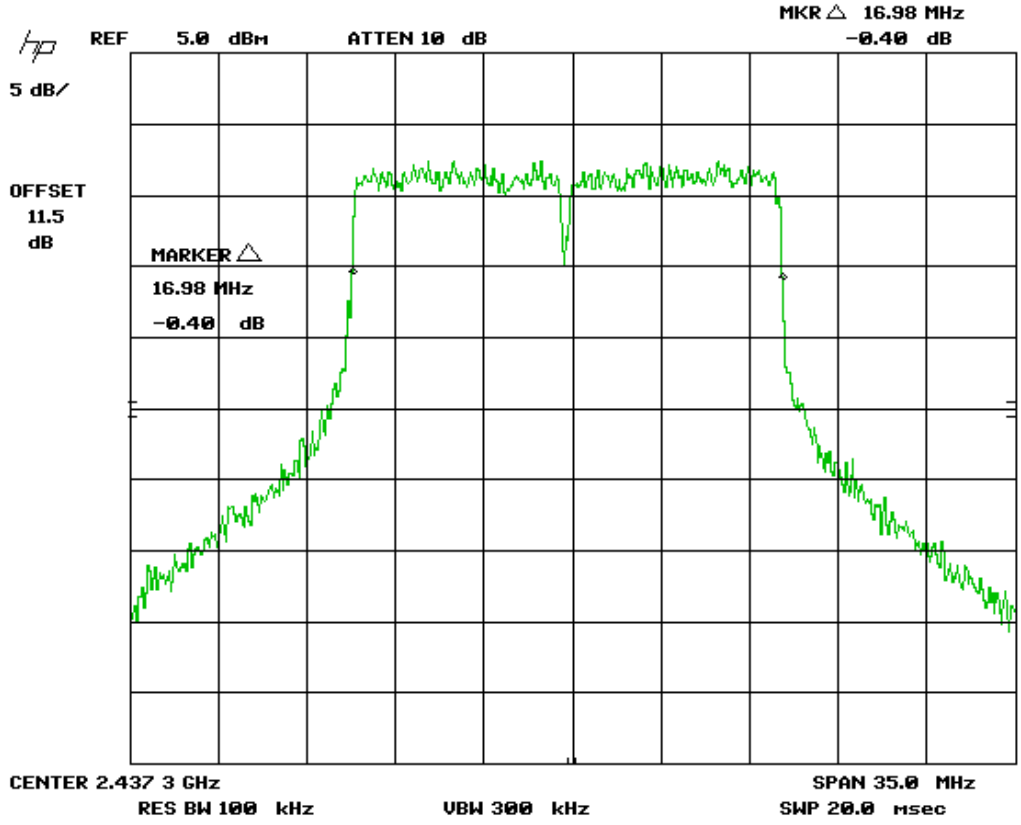

6 dB BW = 16.98 MHz
 20 dB BW = 20.13 MHz

Client	Ecobee Inc	
Product	WEM01	
Standard(s)	RSS 210 Issue 8:2010 / FCC Part 15 Subpart C 15:2014	

N-Protocol, Low Channel

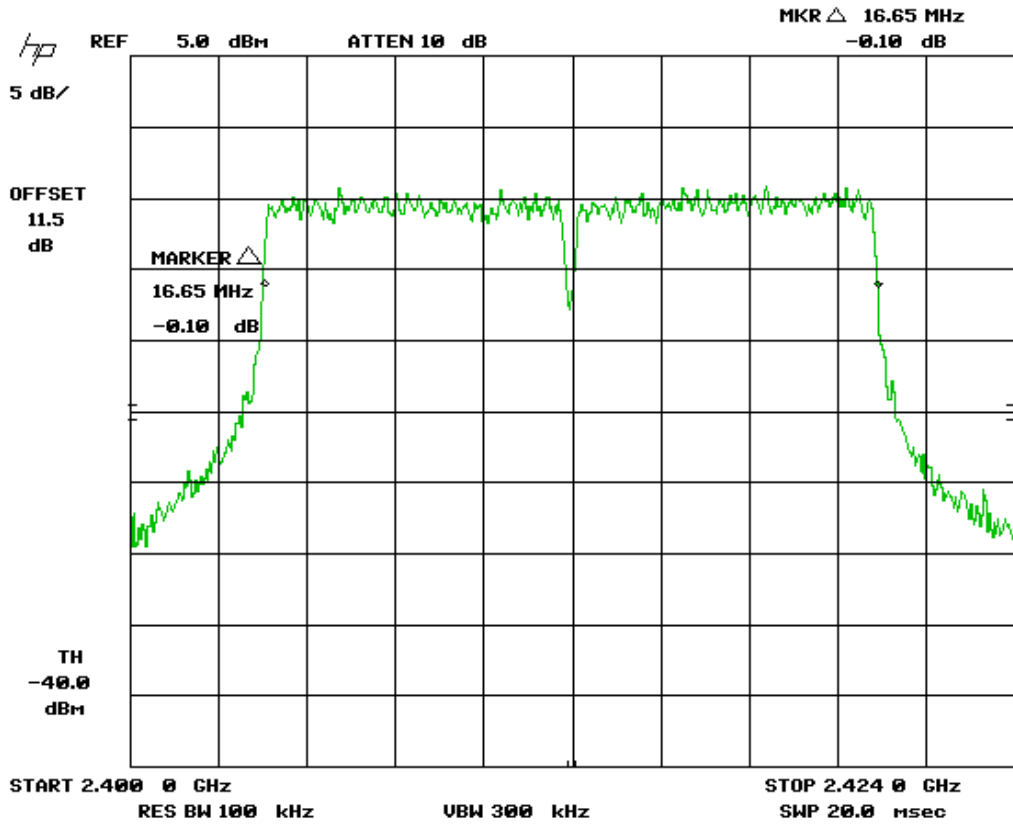

6 dB BW = 16.65 MHz

Client	Ecobee Inc	
Product	WEM01	
Standard(s)	RSS 210 Issue 8:2010 / FCC Part 15 Subpart C 15:2014	

N-Protocol, Low Channel

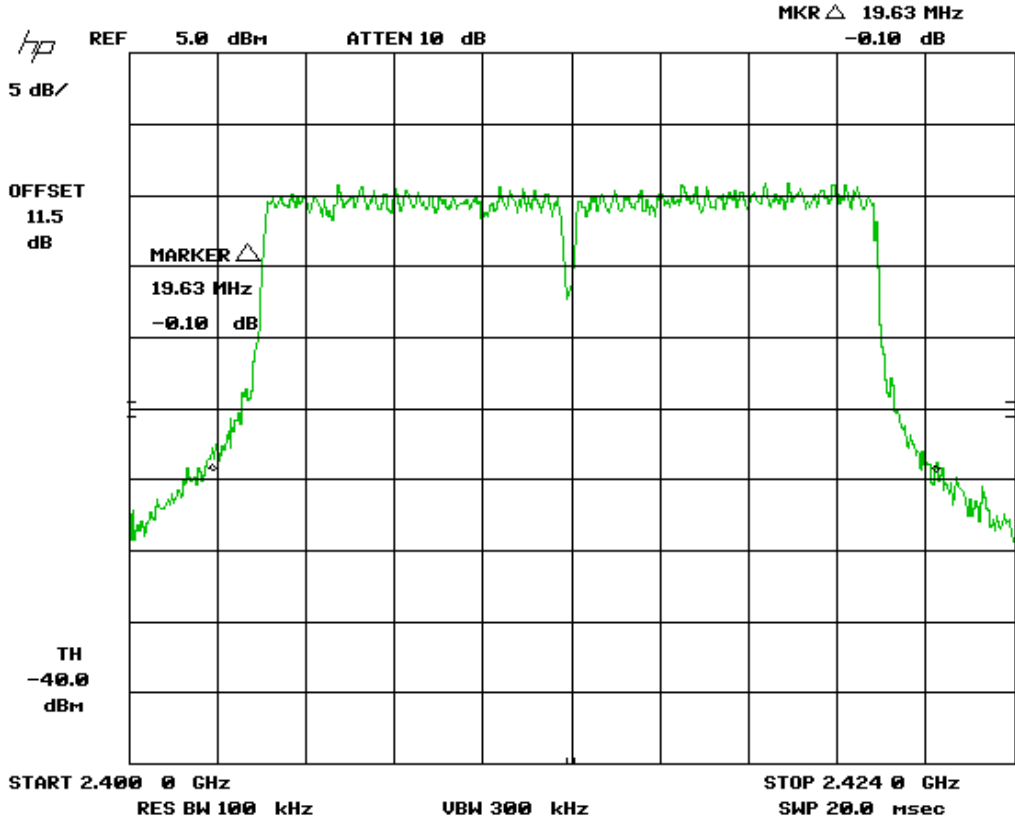

20 dB BW = 19.63 MHz

Note: See 'Appendix B – EUT & Test Setup Photographs' for photos showing the test set-up.

Client	Ecobee Inc	
Product	WEM01	
Standard(s)	RSS 210 Issue 8:2010 / FCC Part 15 Subpart C 15:2014	

Test Equipment List

Equipment	Model No.	Manufacturer	Last calibration date	Next calibration due date	Asset #
Spectrum Analyzer	8566B	HP	Oct 2, 2013	Oct 2, 2015	GEMC 190
Quasi Peak Adapter	85650A	HP	Oct 1, 2013	Oct 1, 2015	GEMC 191
Attenuator 10 dB	8493B	Agilent	NCR	NCR	GEMC133
RF Cable 1m	LMR-400-1M-50OHM-MN-MN	LexTec	NCR	NCR	GEMC 29

This report module is based on GEMC template "FCC – Power Line Conducted Emissions Class B_Rev1"

Client	Ecobee Inc	
Product	WEM01	
Standard(s)	RSS 210 Issue 8:2010 / FCC Part 15 Subpart C 15:2014	

Maximum Peak Envelope Conducted Power - DM

Purpose

The purpose of this test is to ensure that the maximum power conducted to the radiating element does not exceed the limits specified. This ensures that if the end-user replaces the antenna, that the maximum power does not exceed an amount which may create an excessive power level.

Limits and Methods

The limits are defined in FCC Part 15.247(b) and RSS 210.

For systems using digital modulation in the 902-928 MHz, 2400-2483.5 MHz, and 5725-5850 MHz bands, the peak limit is 1 watt.

The method is given in Section 9.1.2 of FCC KDB 558074: June 5, 2014.

Results

The EUT passed. The power of the EUT was set to transmit at maximum power. Three Channels 1, 6, and 11 were measured for each Protocol. The following tables show the peak powers measured

B Protocol						
Channel	Frequency (MHz)	Power (dBm) (raw)	Attenuator (dB)	Cable loss (dB)	Power (dBm)	Power (mW)
Lo Channel (1)	2412	-3.43	10	1.5	8.07	6.41
Mid Channel (6)	2437	-2.16	10	1.5	9.34	8.59
Hi Channel (11)	2462	-2.48	10	1.5	9.02	7.98

G Protocol						
Channel	Frequency (MHz)	Power (dBm) (raw)	Attenuator (dB)	Cable loss (dB)	Power (dBm)	Power (mW)
Lo Channel (1)	2412	3.75	10	1.5	15.25	33.49
Mid Channel (6)	2437	3.79	10	1.5	15.29	33.81
Hi Channel (11)	2462	4.30	10	1.5	15.80	38.02

Client	Ecobee Inc	
Product	WEM01	
Standard(s)	RSS 210 Issue 8:2010 / FCC Part 15 Subpart C 15:2014	

N Protocol						
Channel	Frequency (MHz)	Power (dBm) (raw)	Attenuator (dB)	Cable loss (dB)	Power (dBm)	Power (mW)
Lo Channel (1)	2412	3.08	10	1.5	14.58	28.71
Mid Channel (6)	2437	5.73	10	1.5	17.23	52.84
Hi Channel (11)	2462	5.35	10	1.5	16.85	48.42

Readings

The photos shown below shows the peak power output of the device during the antenna conducted measurement during transmit operation of the EUT.

Tests were conducted using a power meter.



Figure 1: Power reading of B Protocol, Mid channel - photo

Client	Ecobee Inc	
Product	WEM01	
Standard(s)	RSS 210 Issue 8:2010 / FCC Part 15 Subpart C 15:2014	



Figure 2: Power reading of G Protocol, High channel – photo

Client	Ecobee Inc	
Product	WEM01	
Standard(s)	RSS 210 Issue 8:2010 / FCC Part 15 Subpart C 15:2014	



Figure 3: Power reading of N Protocol, Mid channel – photo

Note: See ‘Appendix B – EUT & Test Setup Photographs’ for photos showing the test set-up.

Test Equipment List

Equipment	Model No.	Manufacturer	Last calibration date	Next calibration due date	Asset #
Power Head	PH 2000	AR	Feb 7, 2013	Feb 7, 2015	GEMC 15
Power meter	PM 2002	AR	Feb 7, 2013	Feb 7, 2015	GEMC 16
RF Cable 1m	LMR-400-1M-50OHM-MN-MN	LexTec	NCR	NCR	GEMC 29

This report module is based on GEMC template “FCC – Power Line Conducted Emissions Class B_Rev1”

Client	Ecobee Inc	
Product	WEM01	
Standard(s)	RSS 210 Issue 8:2010 / FCC Part 15 Subpart C 15:2014	

Antenna Spurious Conducted Emissions (-20 dBc Requirement) – 15.247

Purpose

The purpose of this test is to ensure that the maximum power conducted to the radiating element at frequencies outside of the authorized spectrum does not exceed the limits specified. This ensures that the only the intended signal is delivered to the radiating element.

Limits and Methods

The limits are defined in 15.247(d). In any 100 kHz band, the peak spurious harmonics emissions must be at least 20 dB below the fundamental. Spurious Conducted emissions are to be evaluated up to the 10th harmonic. This -20 dBc requirement also applies at the ‘band edge’ or 2.4 GHz and 2.4835 GHz.

The method is given in Section 11 of FCC KDB 558074:June 5, 2014.

Results

The EUT passed the limits. B, G and N protocols are measured; low, middle and high channels were measured for each Protocol. The worst case was presented as a graph for the spectrum. The -20 dBc requirement is shown for the lower band edge at 2.4 GHz in the low band. The -20 dBc requirement is also shown for the higher band edge at 2.4835 GHz in the high band.

Client	Ecobee Inc	
Product	WEM01	
Standard(s)	RSS 210 Issue 8:2010 / FCC Part 15 Subpart C 15:2014	

Graph(s)

The graphs shown below shows the peak power output of the device during the antenna conducted measurement during transmit operation of the EUT.

B Protocol, Hi Channel 9 kHz – 2.5 GHz

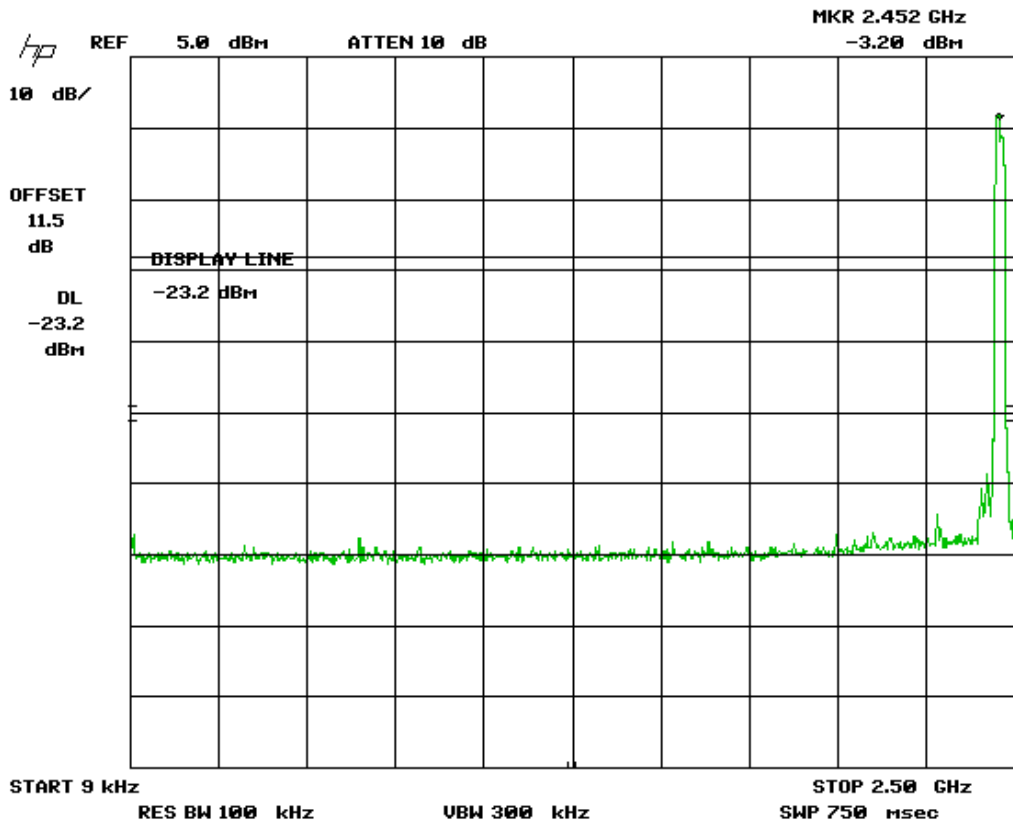

Client	Ecobee Inc	
Product	WEM01	
Standard(s)	RSS 210 Issue 8:2010 / FCC Part 15 Subpart C 15:2014	

B Protocol, Hi Channel 2.4 GHz – 24 GHz

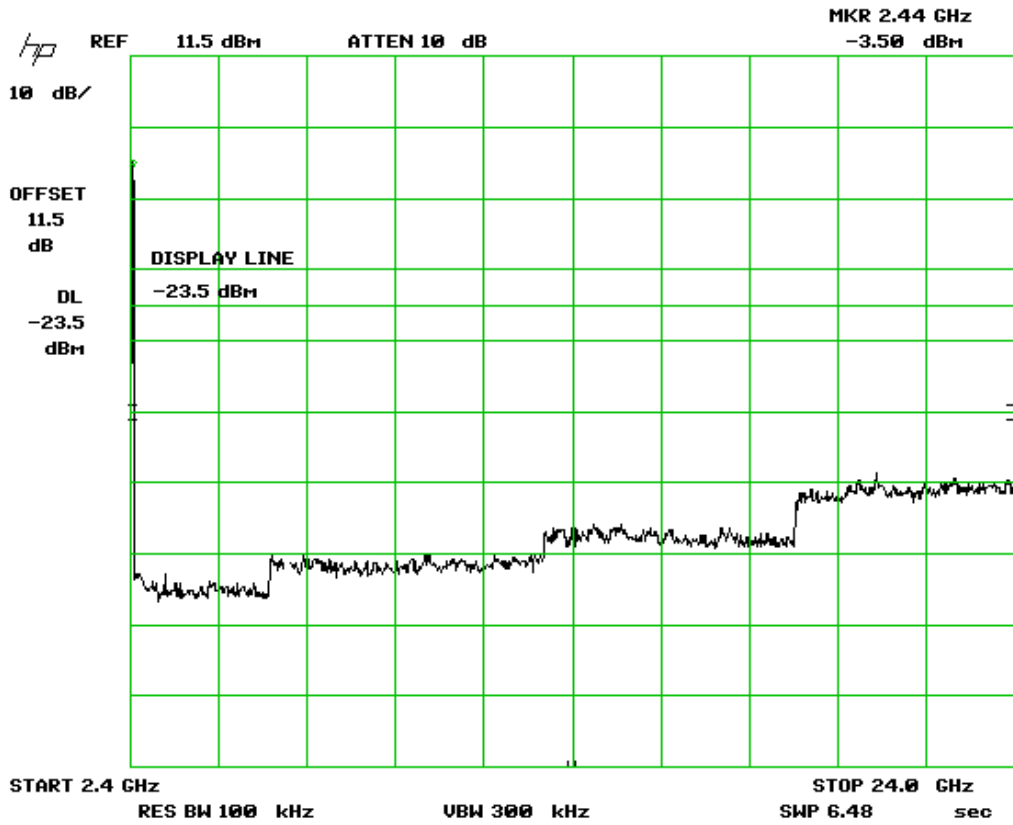

Client	Ecobee Inc	
Product	WEM01	
Standard(s)	RSS 210 Issue 8:2010 / FCC Part 15 Subpart C 15:2014	

B Protocol, Hi Channel – 2483.5 Band Edge

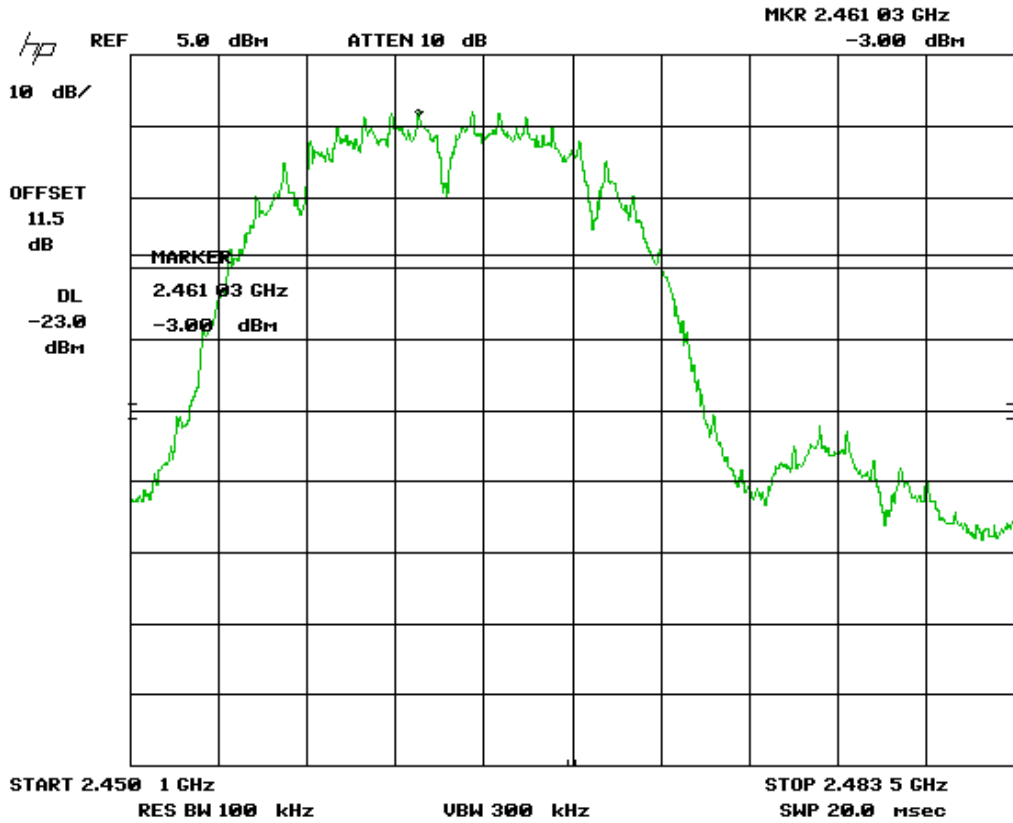

Client	Ecobee Inc	
Product	WEM01	
Standard(s)	RSS 210 Issue 8:2010 / FCC Part 15 Subpart C 15:2014	

B Protocol, Low Channel – 2400 MHz Band edge

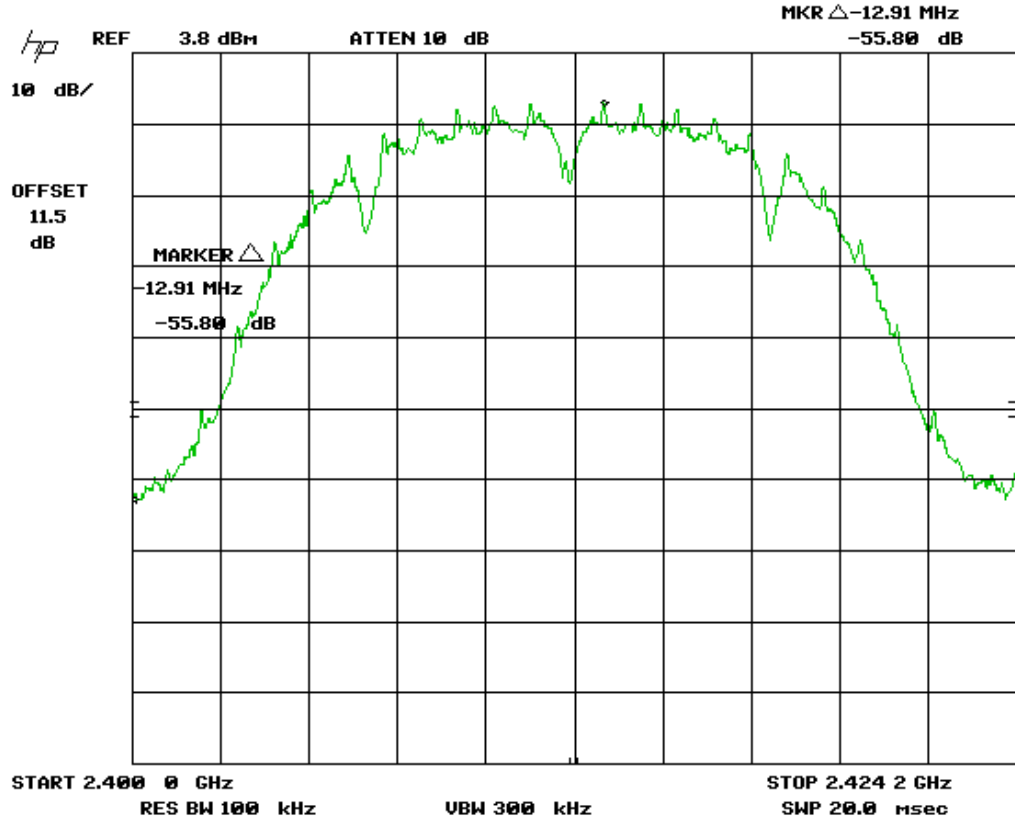

Client	Ecobee Inc	
Product	WEM01	
Standard(s)	RSS 210 Issue 8:2010 / FCC Part 15 Subpart C 15:2014	

G Protocol, Hi Channel 9 kHz – 2.5 GHz

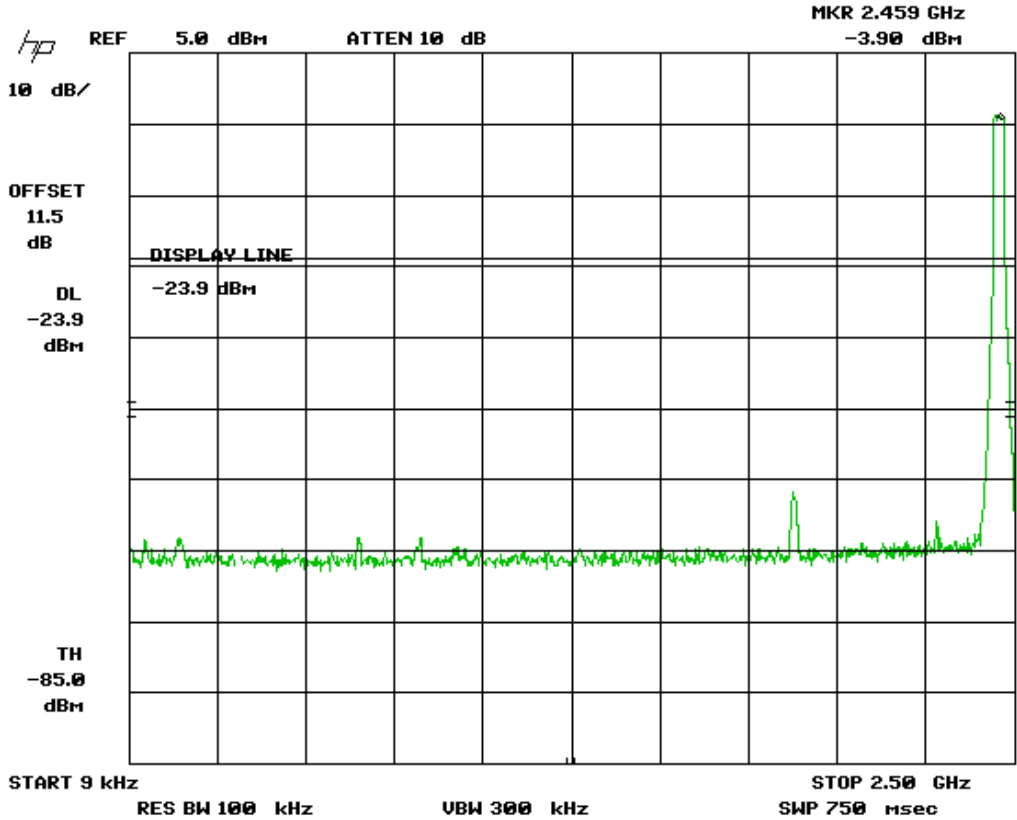

Client	Ecobee Inc	
Product	WEM01	
Standard(s)	RSS 210 Issue 8:2010 / FCC Part 15 Subpart C 15:2014	

G Protocol, Hi Channel 2.4 GHz – 24 GHz

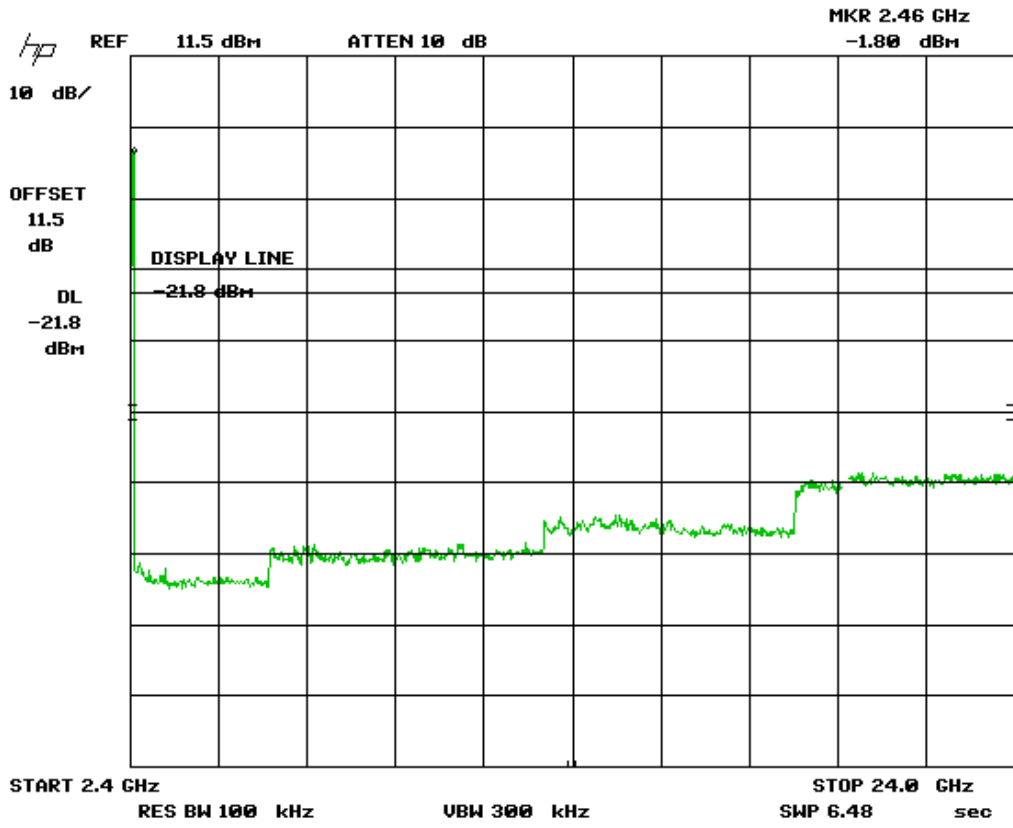

Client	Ecobee Inc	
Product	WEM01	
Standard(s)	RSS 210 Issue 8:2010 / FCC Part 15 Subpart C 15:2014	

G Protocol, Hi Channel – 2483.5 Band edge

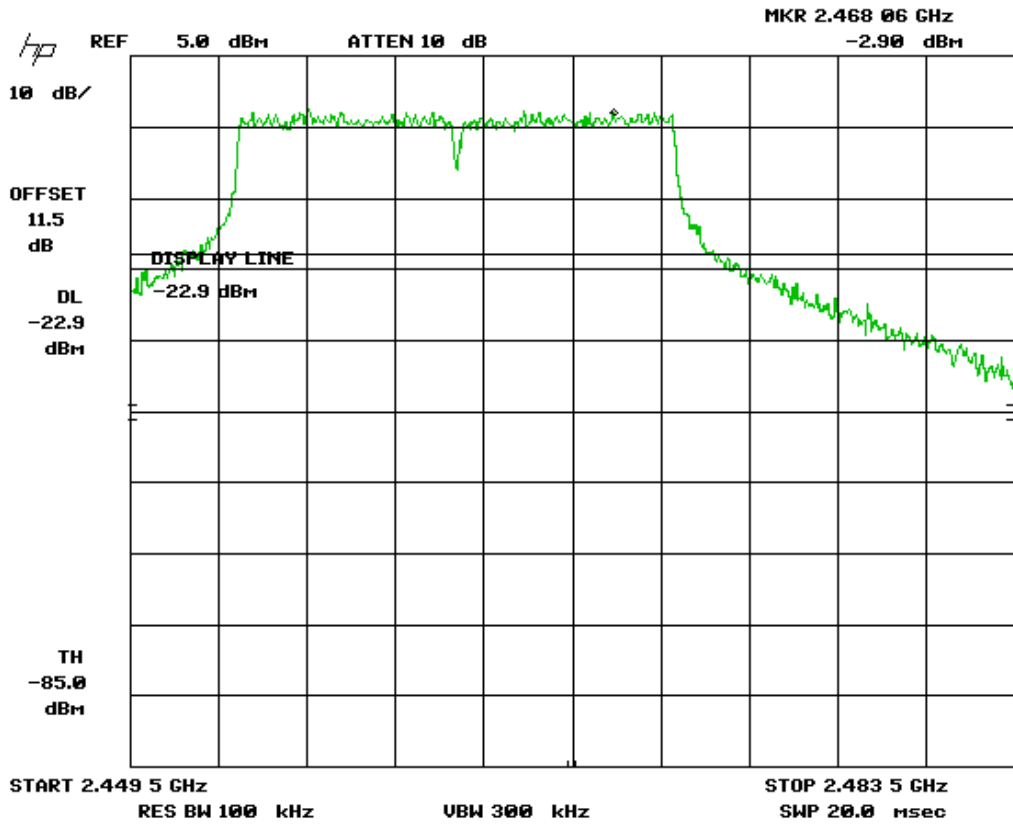

Client	Ecobee Inc	
Product	WEM01	
Standard(s)	RSS 210 Issue 8:2010 / FCC Part 15 Subpart C 15:2014	

G Protocol, Low Channel – 2400 Band edge

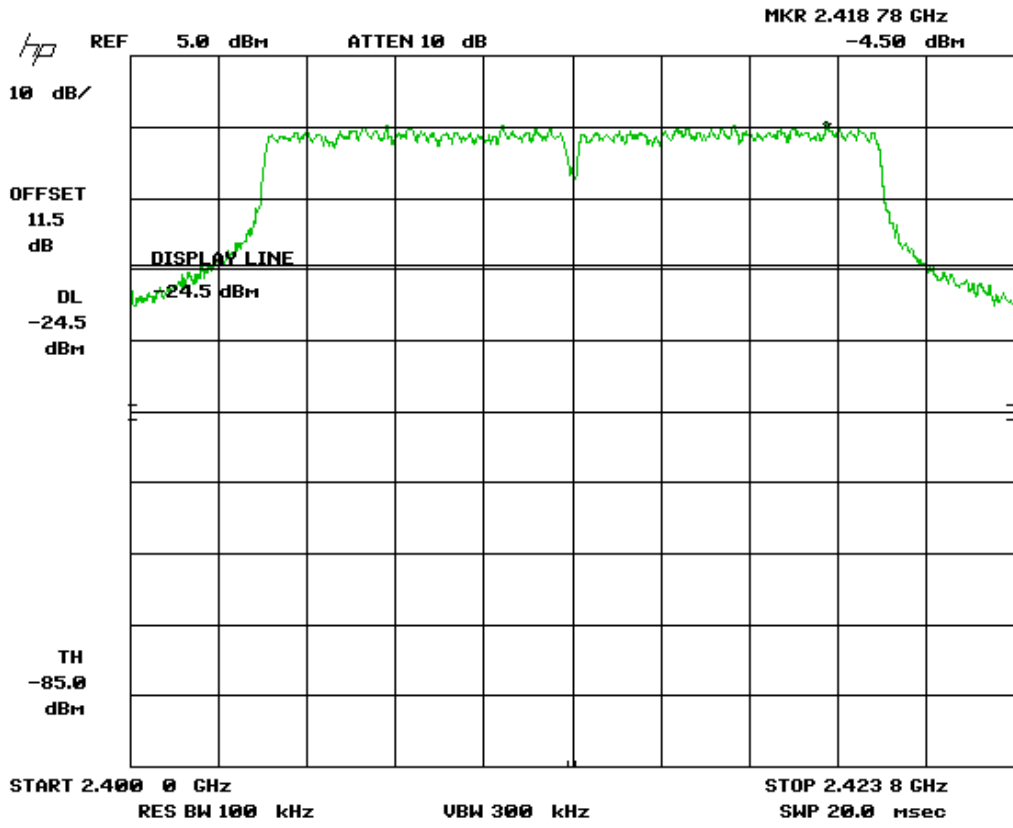

Client	Ecobee Inc	
Product	WEM01	
Standard(s)	RSS 210 Issue 8:2010 / FCC Part 15 Subpart C 15:2014	

N Protocol, Hi Channel 9 kHz – 2.5 GHz

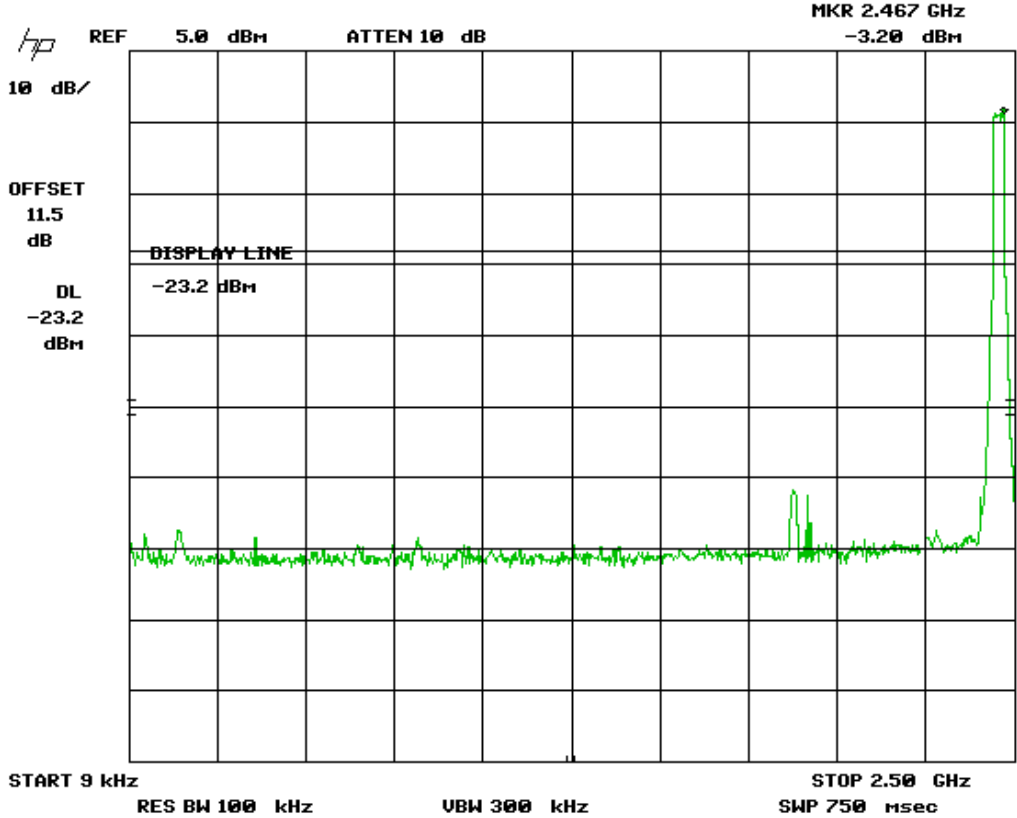

Client	Ecobee Inc	
Product	WEM01	
Standard(s)	RSS 210 Issue 8:2010 / FCC Part 15 Subpart C 15:2014	

N Protocol, Hi Channel 2.4 GHz – 24 GHz

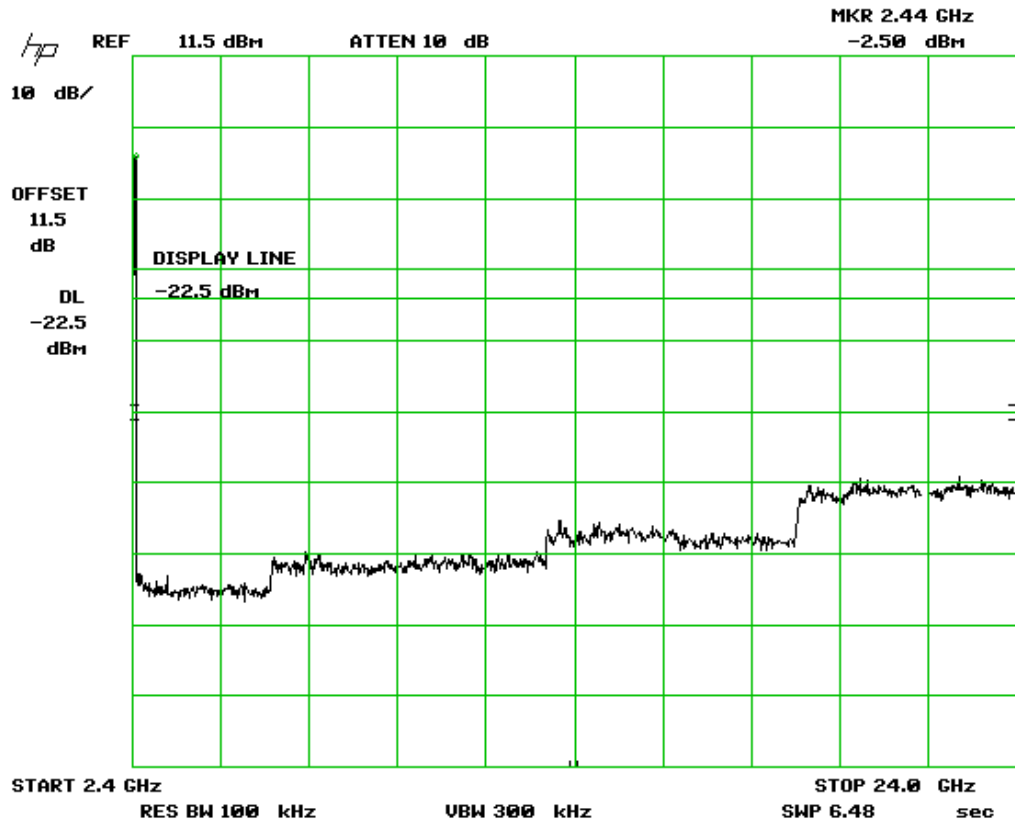

Client	Ecobee Inc	
Product	WEM01	
Standard(s)	RSS 210 Issue 8:2010 / FCC Part 15 Subpart C 15:2014	

N Protocol, Hi Channel – 2483.5 Band edge

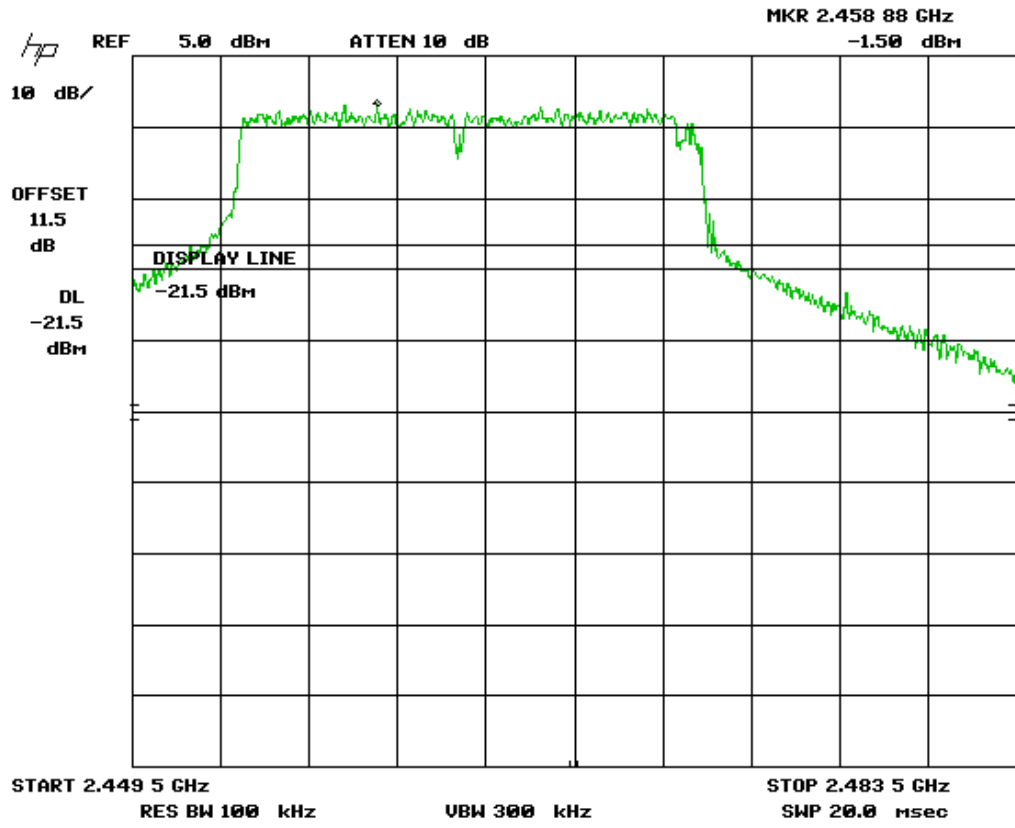

Client	Ecobee Inc	
Product	WEM01	
Standard(s)	RSS 210 Issue 8:2010 / FCC Part 15 Subpart C 15:2014	

N Protocol, Low Channel – 2400 Band edge

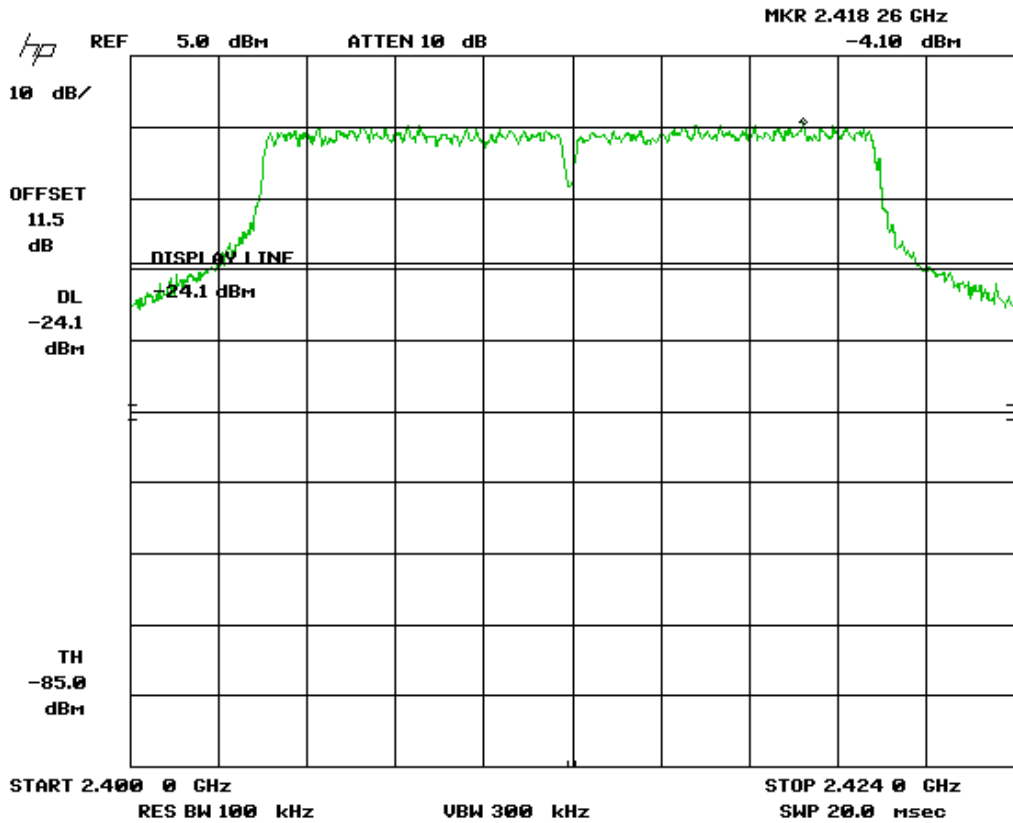

Note: See ‘Appendix B – EUT & Test Setup Photographs’ for photos showing the test set-up.

Test Equipment List

Equipment	Model No.	Manufacturer	Last calibration date	Next calibration due date	Asset #
Spectrum Analyzer	8566B	HP	Oct 2, 2013	Oct 2, 2015	GEMC 190
Quasi Peak Adapter	85650A	HP	Oct 1, 2013	Oct 1, 2015	GEMC 191
Attenuator 10 dB	8493B	Agilent	NCR	NCR	GEMC133
RF Cable 1m	LMR-400-1M-50OHM-MN-MN	LexTec	NCR	NCR	GEMC 29

This report module is based on GEMC template “FCC – Power Line Conducted Emissions Class B_Rev1”

Client	Ecobee Inc	
Product	WEM01	
Standard(s)	RSS 210 Issue 8:2010 / FCC Part 15 Subpart C 15:2014	

Radiated Emissions – 15.247

Purpose

The purpose of this test is to ensure that the RF energy unintentionally emitted from the EUT does not exceed the limits listed below as defined in the applicable test standard, as measured from a receiving antenna. This helps protect broadcast radio services such as television, FM radio, pagers, cellular telephones, emergency services, and so on, from unwanted interference.

Limit and Method

The method is given in Section 12.1 of FCC KDB 558074: June 5, 2014

The limits are as defined in FCC Part 15, Section 15.209:

The limits, as defined in 15.247(d) for unintentional radiated emissions apply for those emissions that fall in the restricted bands, as defined in Section 15.205(a). These emissions must comply with the radiated emission limits specified in Section 15.209(a).

All unintentional emissions must also meet the ‘Spurious Conducted Emissions’ requirements of -20 dBc or greater. See also ‘Spurious Conducted Emissions’ for further details.

0.009 MHz – 0.490 MHz, 2400/F(kHz) uV/m at 300 m¹
0.490 MHz – 1.705 MHz, 24000/F(kHz) uV/m at 30 m¹
1.705 MHz – 30 MHz, 30 uV/m at 30 m¹
30 MHz – 88 MHz, 100 uV/m (40.0 dBuV/m¹) at 3 m
88 MHz – 216 MHz, 150 uV/m (43.5 dBuV/m¹) at 3 m
216 MHz – 960 MHz, 200 uV/m (46.0 dBuV/m¹) at 3 m
Above 960 MHz, 500 uV/m (54.0 dBuV/m¹) at 3 m
Above 1000 MHz, 500 uV/m (54 dBuV/m²) at 3m
Above 1000 MHz, 500 uV/m (74 dBuV/m³) at 3m

¹Limit is with Quasi Peak detector with bandwidths as defined in CISPR-16-1-1

²Limit is with 1 MHz measurement bandwidth and using an Average detector

³Limit is with 1 MHz measurement bandwidth and using a Peak detector

Client	Ecobee Inc	
Product	WEM01	
Standard(s)	RSS 210 Issue 8:2010 / FCC Part 15 Subpart C 15:2014	

Typical Radiated Emissions Setup

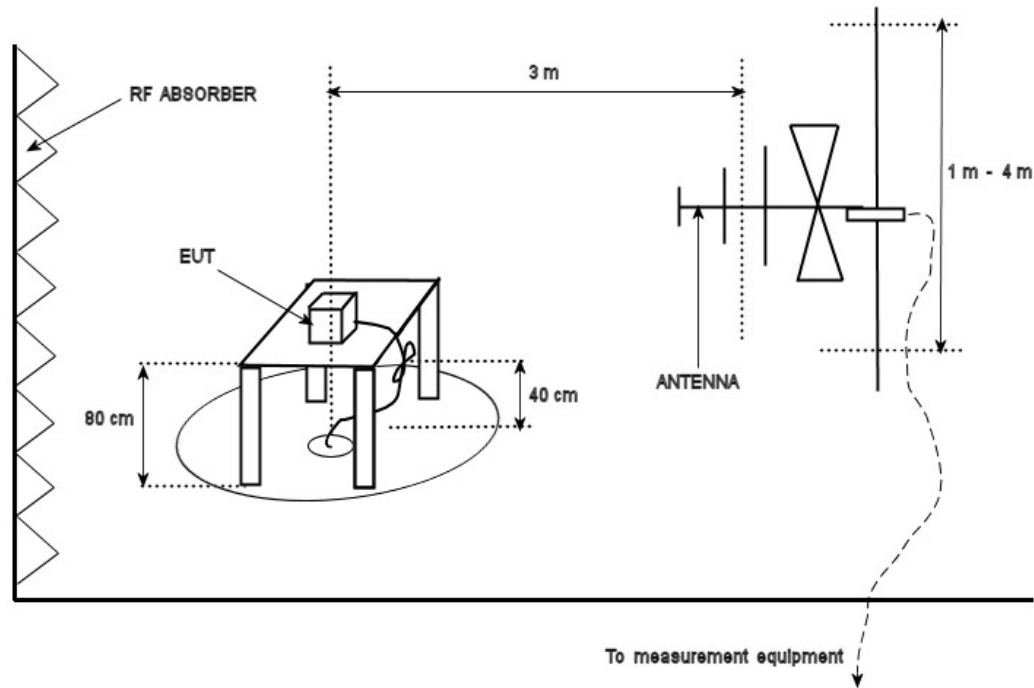

Measurement Uncertainty

The expanded measurement uncertainty is calculated in accordance with CISPR 16-4-2 and is +/-4.4 dB with a 'k=2' coverage factor and a 95% confidence level.

Preliminary Graphs

Note the graphs shown below are for graphical illustration only. For final measurements with the appropriate detector, please refer to the final measurement table where applicable. The graph shown below is a maximized peak measurement graph, measured with a resolution bandwidth greater than the final required detector and over a full 0-360 rotation. This peaking process is done as a worst case measurement. This process enables the detection of frequencies of concern for final measurement, and provides considerable time savings.

In accordance with FCC Part 15, Subpart A, Section 15.33, the device was scanned to the 10th harmonic (a minimum of a 24.835 GHz).

Devices scanned may be scanned at alternate test distances, and in accordance with FCC Part 15, Subpart A, Section 15.31, an extrapolation factor of 20 dB/decade was used above

Client	Ecobee Inc	
Product	WEM01	
Standard(s)	RSS 210 Issue 8:2010 / FCC Part 15 Subpart C 15:2014	

30 MHz and 40 dB/decade below 30 MHz. For example for 1 meter measurements, an extrapolation factor 9.5 dB from 20 Log (1m / 3m) is applied.

B, G and N protocols were measured. For each protocol, low, middle and high channels were measured, each in three orthogonal axes were checked; however the worst case graphs are presented.

Band edge measure graphs were shown for illustrations purpose. See final measurement section for all measurements.

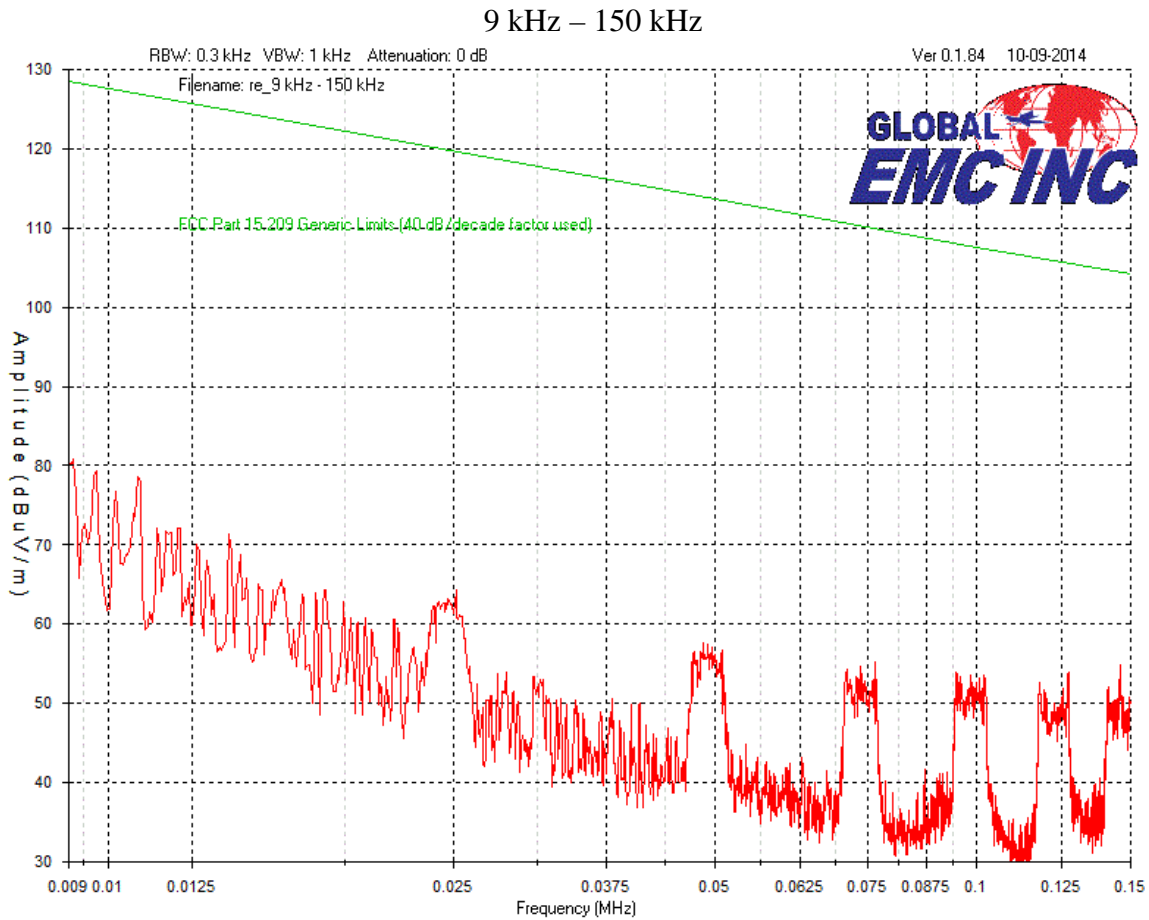

Client	Ecobee Inc	
Product	WEM01	
Standard(s)	RSS 210 Issue 8:2010 / FCC Part 15 Subpart C 15:2014	

150 kHz – 30 MHz

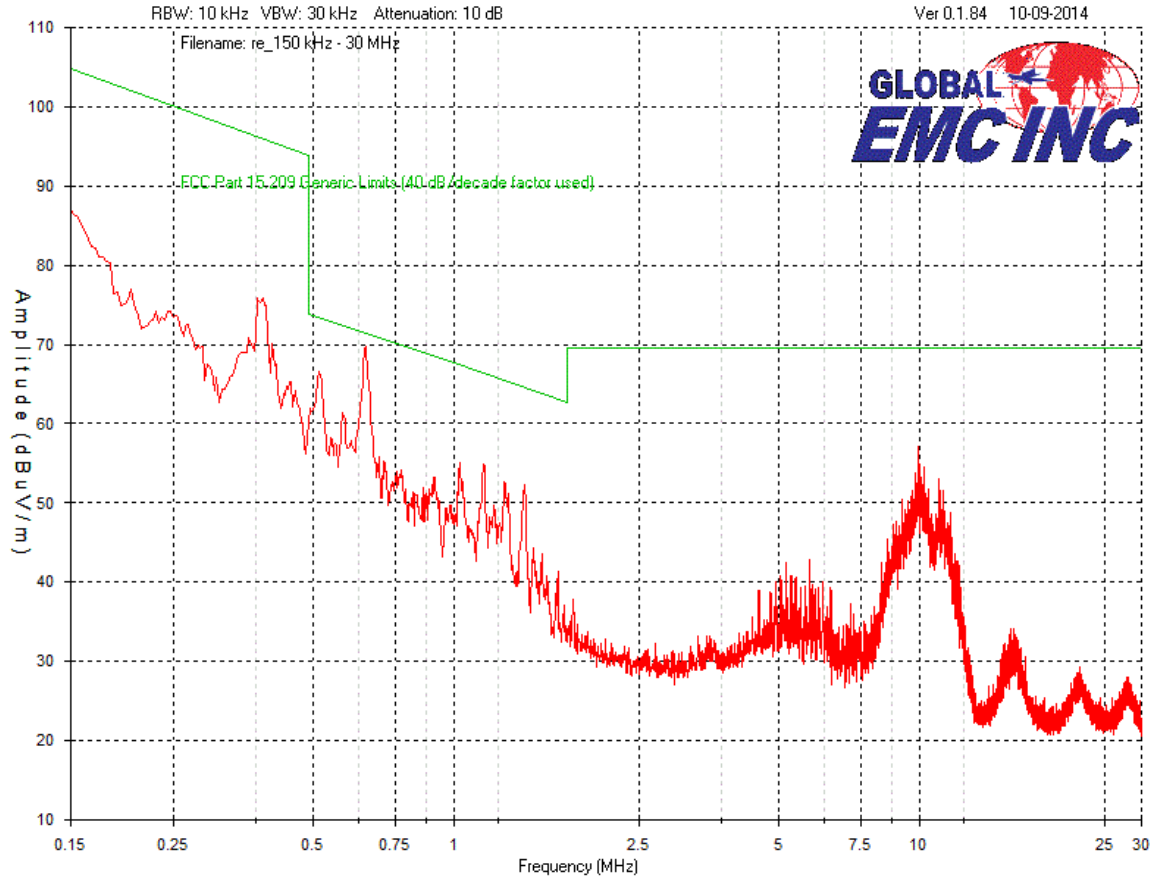

Client	Ecobee Inc	
Product	WEM01	
Standard(s)	RSS 210 Issue 8:2010 / FCC Part 15 Subpart C 15:2014	

**Mid Channel - 30 MHz – 1 GHz
Vertical – Peak Emission Graph**

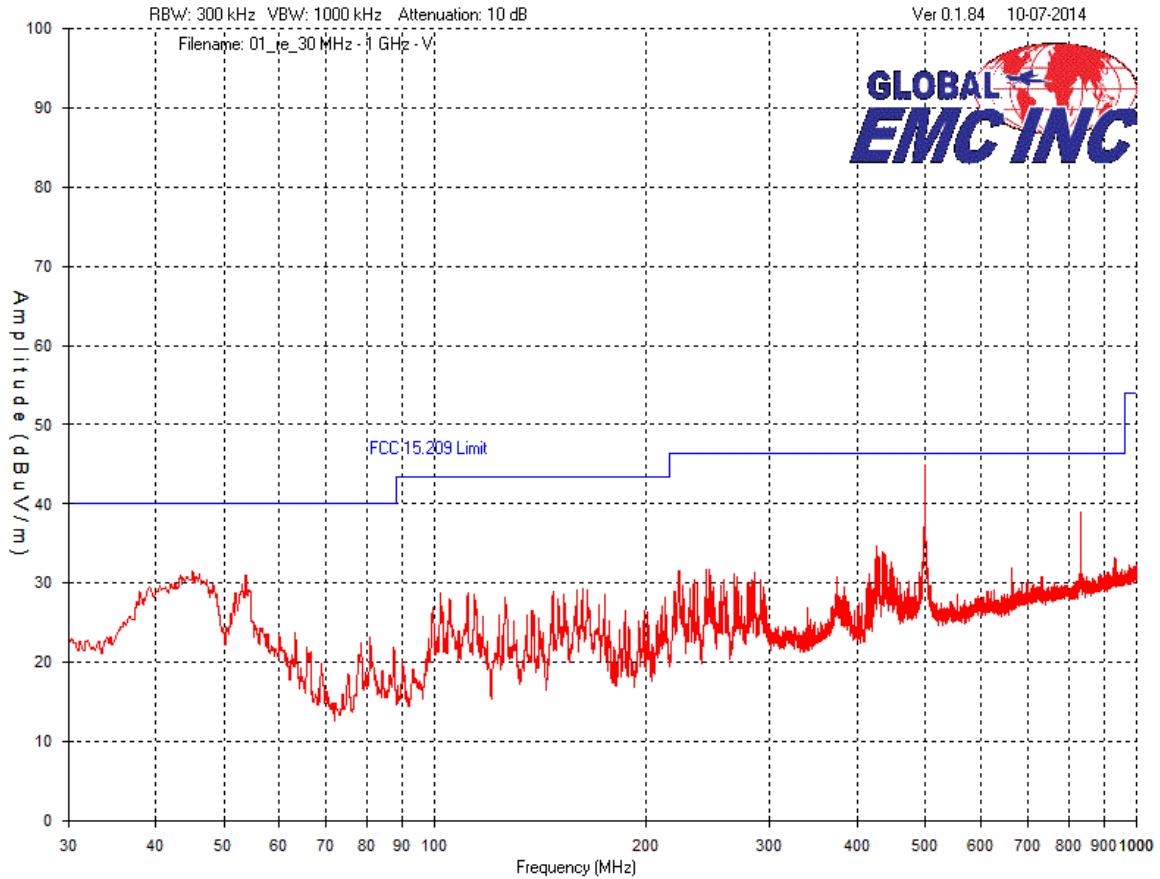

Note: See Final Measurements and Results section on page 84 for measurements and explanations.

Client	Ecobee Inc	
Product	WEM01	
Standard(s)	RSS 210 Issue 8:2010 / FCC Part 15 Subpart C 15:2014	

**Mid Channel – 30 MHz – 1 GHz
Horizontal - Peak Emission Graph**

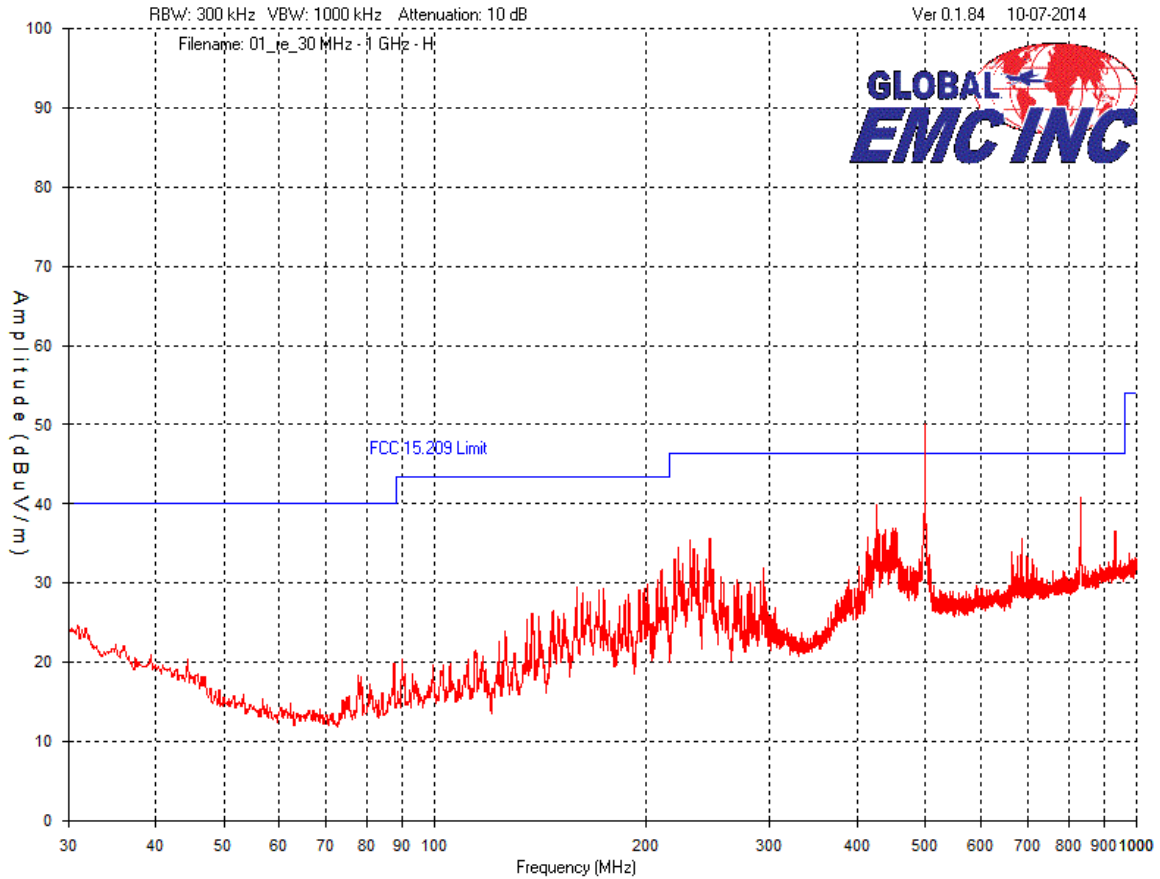

Note: See Final Measurements and Results section on page 84 for measurements and explanations.

Client	Ecobee Inc	
Product	WEM01	
Standard(s)	RSS 210 Issue 8:2010 / FCC Part 15 Subpart C 15:2014	

Mid Channel – 1 GHz – 2 GHz
Vertical - Peak Emission Graph

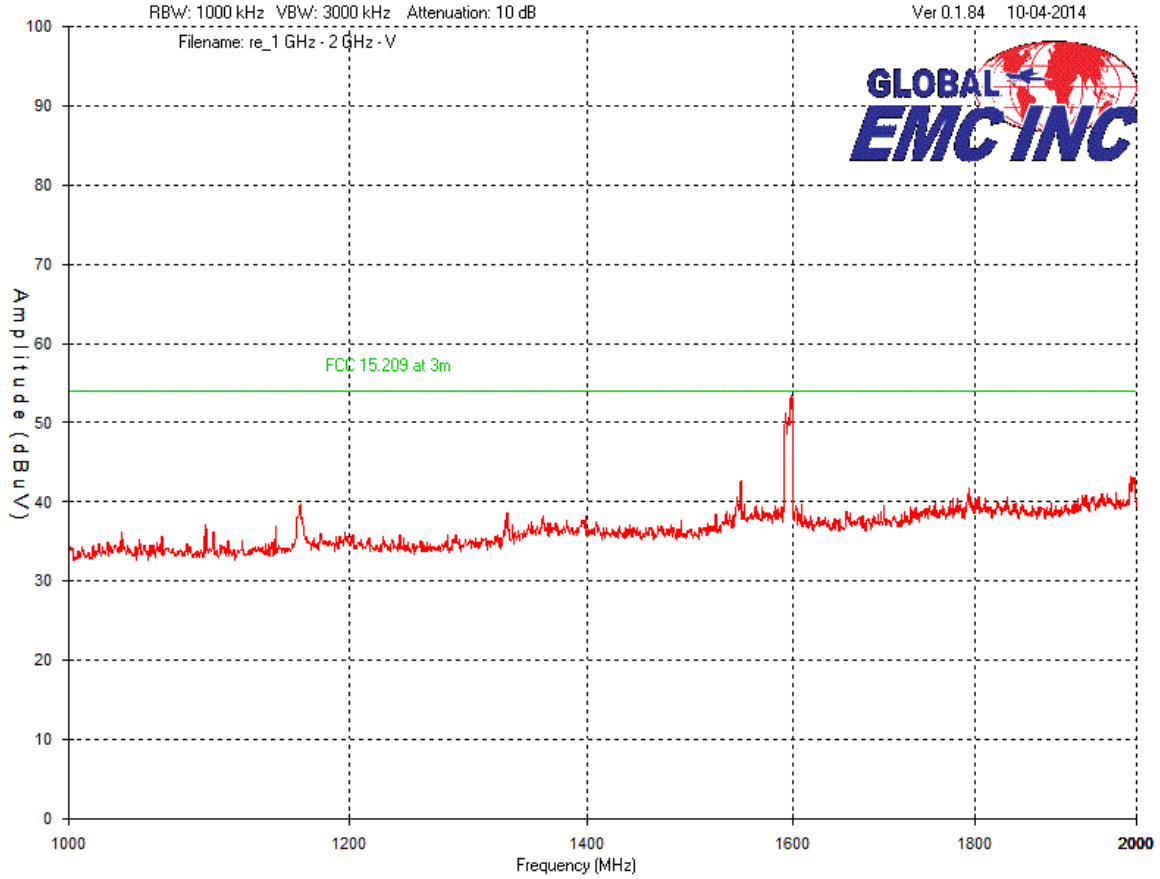

Client	Ecobee Inc	
Product	WEM01	
Standard(s)	RSS 210 Issue 8:2010 / FCC Part 15 Subpart C 15:2014	

Mid Channel – 1 GHz – 2 GHz
Horizontal - Peak Emission Graph

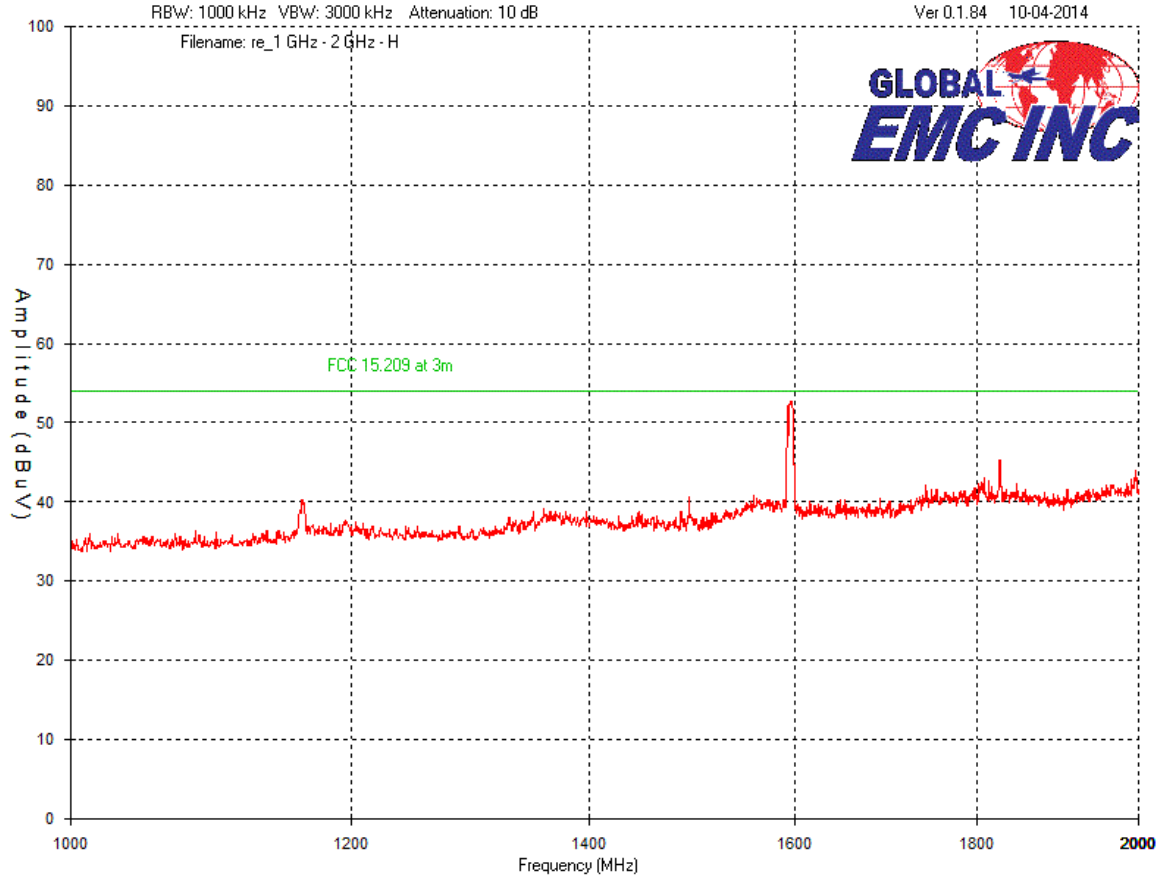

Client	Ecobee Inc	
Product	WEM01	
Standard(s)	RSS 210 Issue 8:2010 / FCC Part 15 Subpart C 15:2014	

Mid Channel – 2 GHz – 10 GHz
Horizontal - Peak Emission Graph

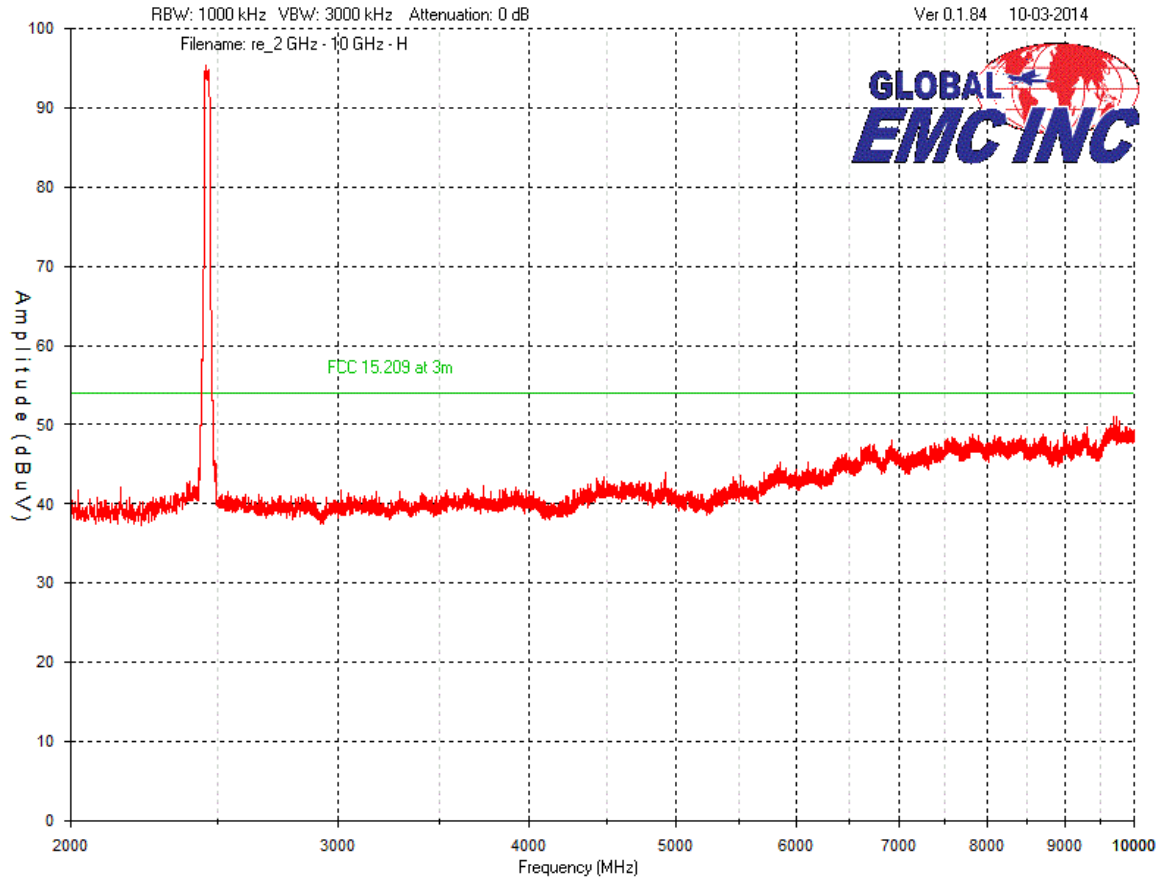

Note: See Final Measurements and Results section starting on page 84 for measurements.

Client	Ecobee Inc	
Product	WEM01	
Standard(s)	RSS 210 Issue 8:2010 / FCC Part 15 Subpart C 15:2014	

Mid Channel – 2 GHz – 10 GHz
Vertical - Peak Emission Graph

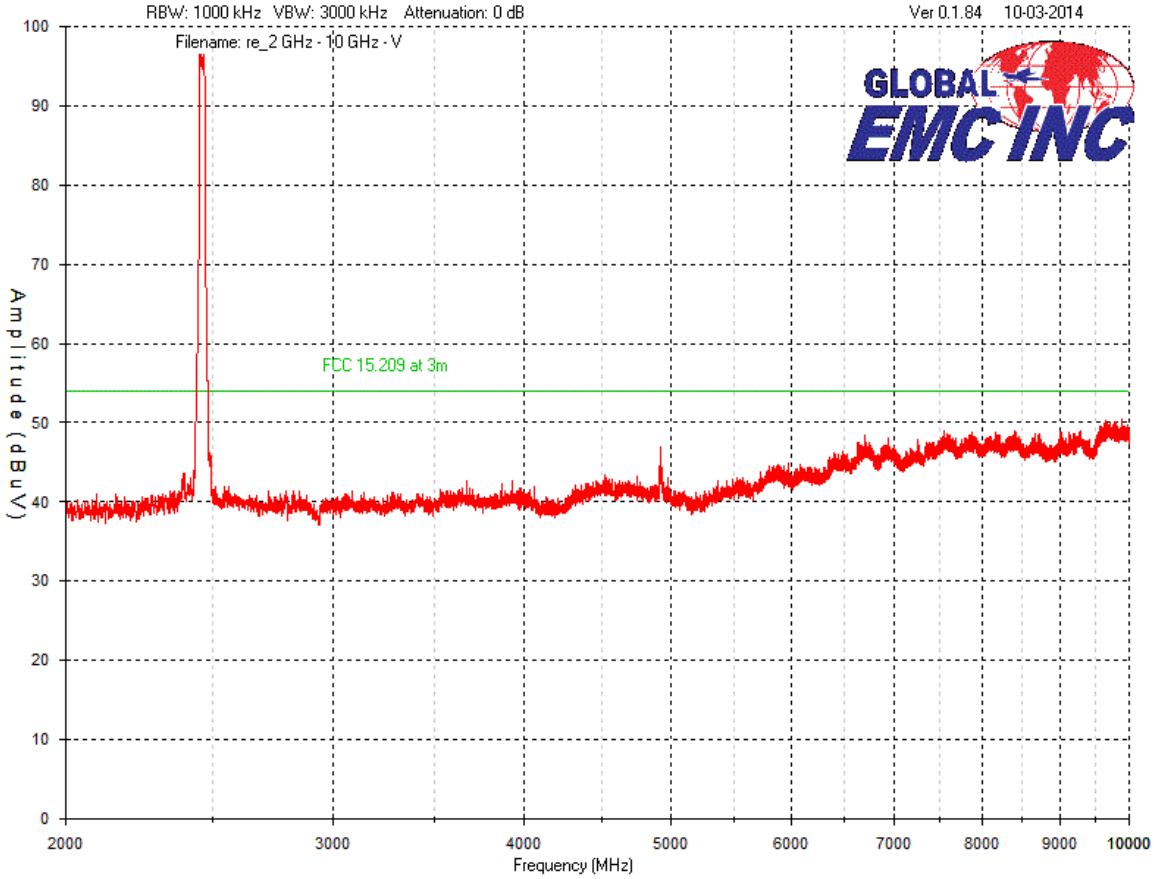

Client	Ecobee Inc	
Product	WEM01	
Standard(s)	RSS 210 Issue 8:2010 / FCC Part 15 Subpart C 15:2014	

Mid Channel – 10 GHz – 18 GHz
Horizontal - Peak Emission Graph

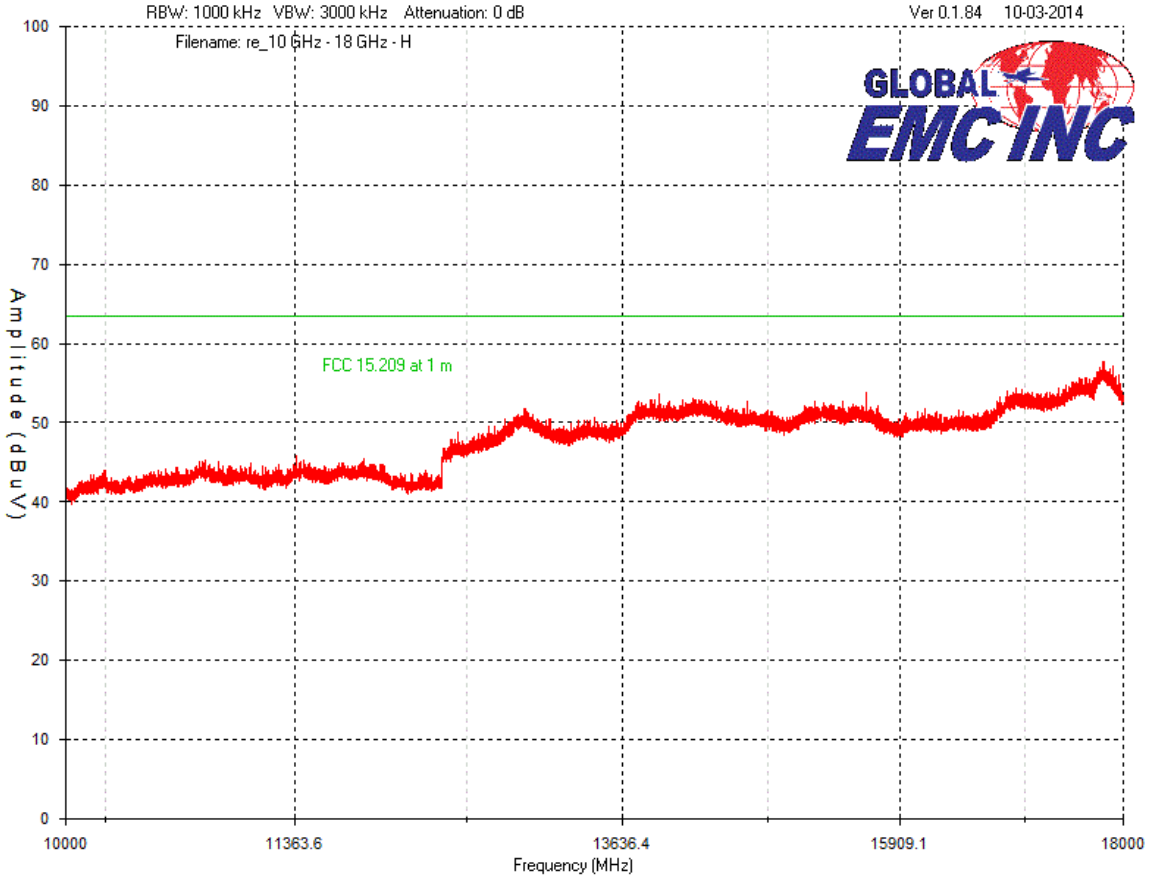

Note: See Final Measurements and Results section starting on page 84 for details.

Client	Ecobee Inc	
Product	WEM01	
Standard(s)	RSS 210 Issue 8:2010 / FCC Part 15 Subpart C 15:2014	

**Mid Channel – 6 GHz – 18 GHz
Vertical - Peak Emission Graph**

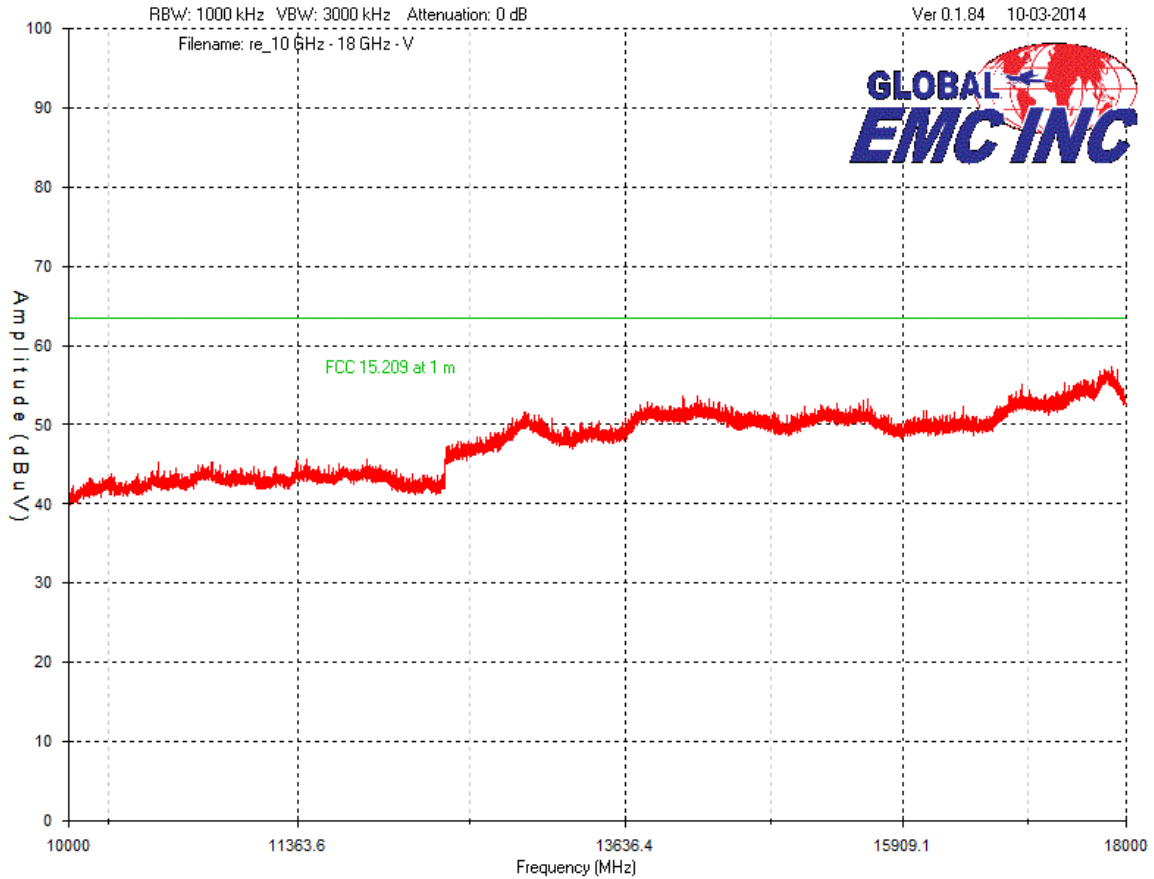

Note: See Final Measurements and Results section starting on page 84 for details.

Client	Ecobee Inc	
Product	WEM01	
Standard(s)	RSS 210 Issue 8:2010 / FCC Part 15 Subpart C 15:2014	

Mid Channel – 18 GHz – 26 GHz
Horizontal - Peak Emission Graph

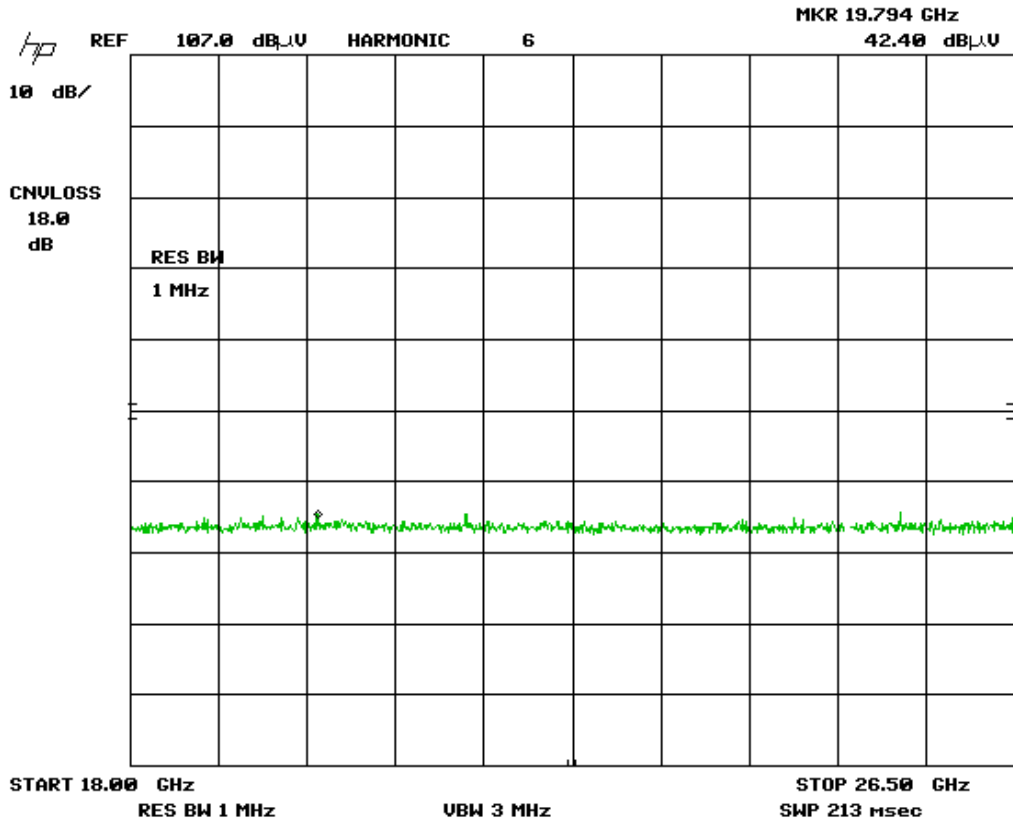

Plot was taken at 1 meter distances. All emission shown were instrument noise floor of measurement instrument. No emissions were found in this frequency range.

Client	Ecobee Inc	
Product	WEM01	
Standard(s)	RSS 210 Issue 8:2010 / FCC Part 15 Subpart C 15:2014	

Mid Channel – 18 GHz – 26 GHz
Vertical - Peak Emission Graph

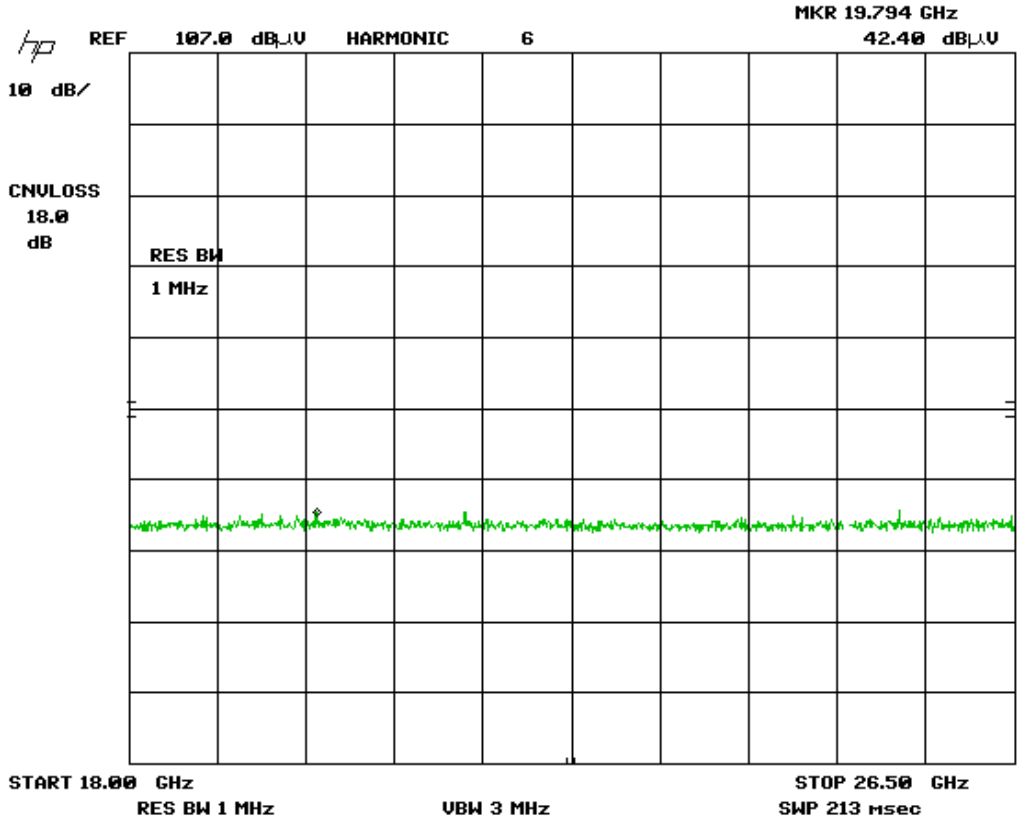

Plot was taken at 1 meter distances. All emission shown were instrument noise floor of measurement instrument. No emissions were found in this frequency range.

Client	Ecobee Inc	
Product	WEM01	
Standard(s)	RSS 210 Issue 8:2010 / FCC Part 15 Subpart C 15:2014	

B Protocol, Band Edge – Low Channel
Vertical - Peak Emission

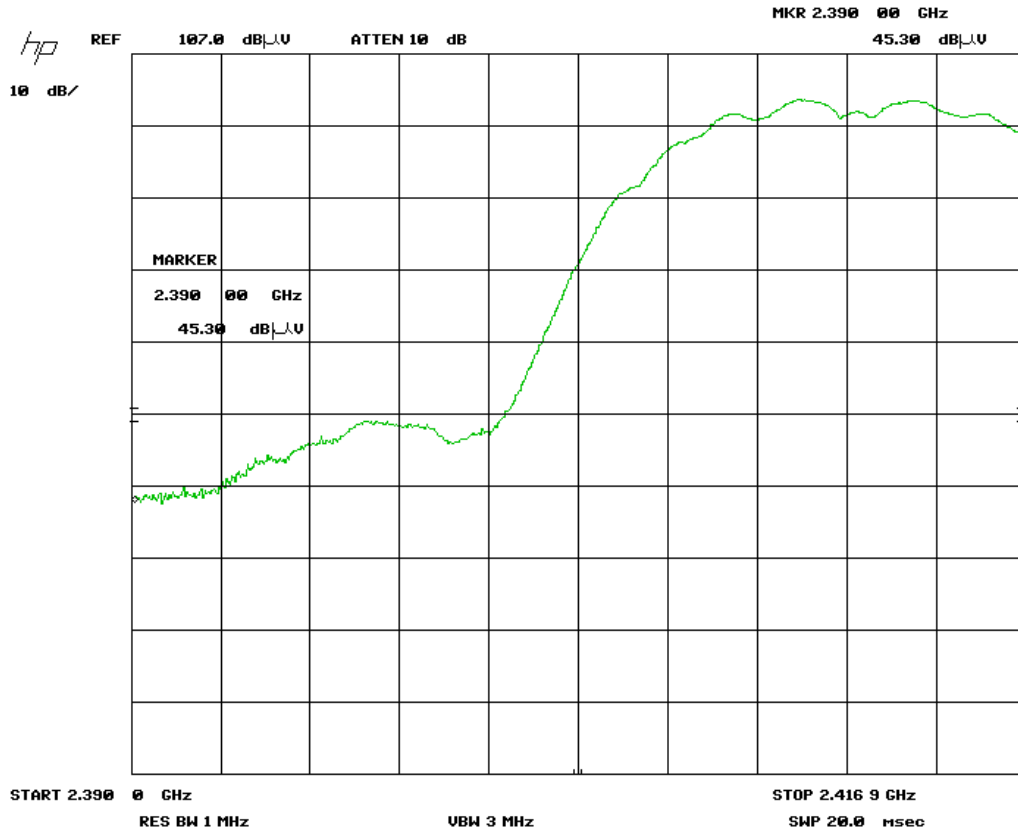

Note: Bandedge plots were taken with 3 m measurements distance. The marker shows the raw value; see Final Measurements and Results section for corrected values.

Client	Ecobee Inc	
Product	WEM01	
Standard(s)	RSS 210 Issue 8:2010 / FCC Part 15 Subpart C 15:2014	

B Protocol, Band Edge – Low Channel
Horizontal - Peak Emission

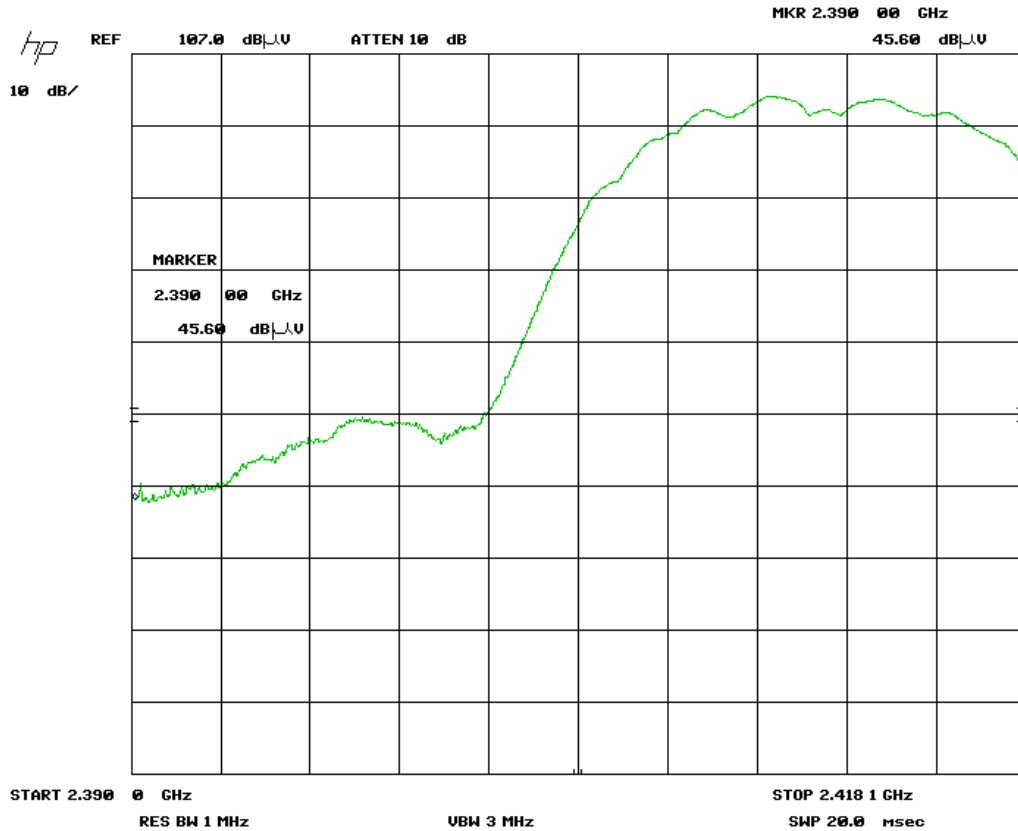

Note: Bandedge plots were taken with 3 m measurements distance. The marker shows the raw value; see Final Measurements and Results section for corrected values.

Client	Ecobee Inc	
Product	WEM01	
Standard(s)	RSS 210 Issue 8:2010 / FCC Part 15 Subpart C 15:2014	

B Protocol, Band Edge – Low Channel
Vertical – Average Emission

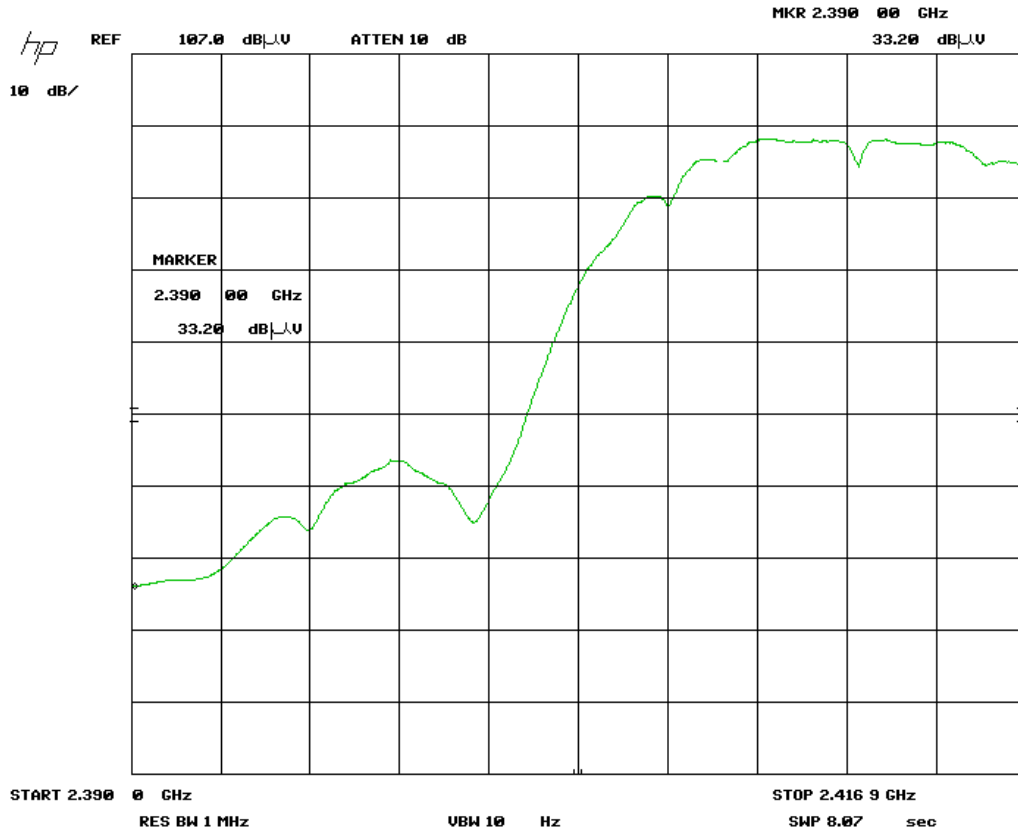

Note: Bandedge plots were taken with 3 m measurements distance. The marker shows the raw value; see Final Measurements and Results section for corrected values.

Client	Ecobee Inc	
Product	WEM01	
Standard(s)	RSS 210 Issue 8:2010 / FCC Part 15 Subpart C 15:2014	

B Protocol, Band Edge – Low Channel
Horizontal - Average Emission

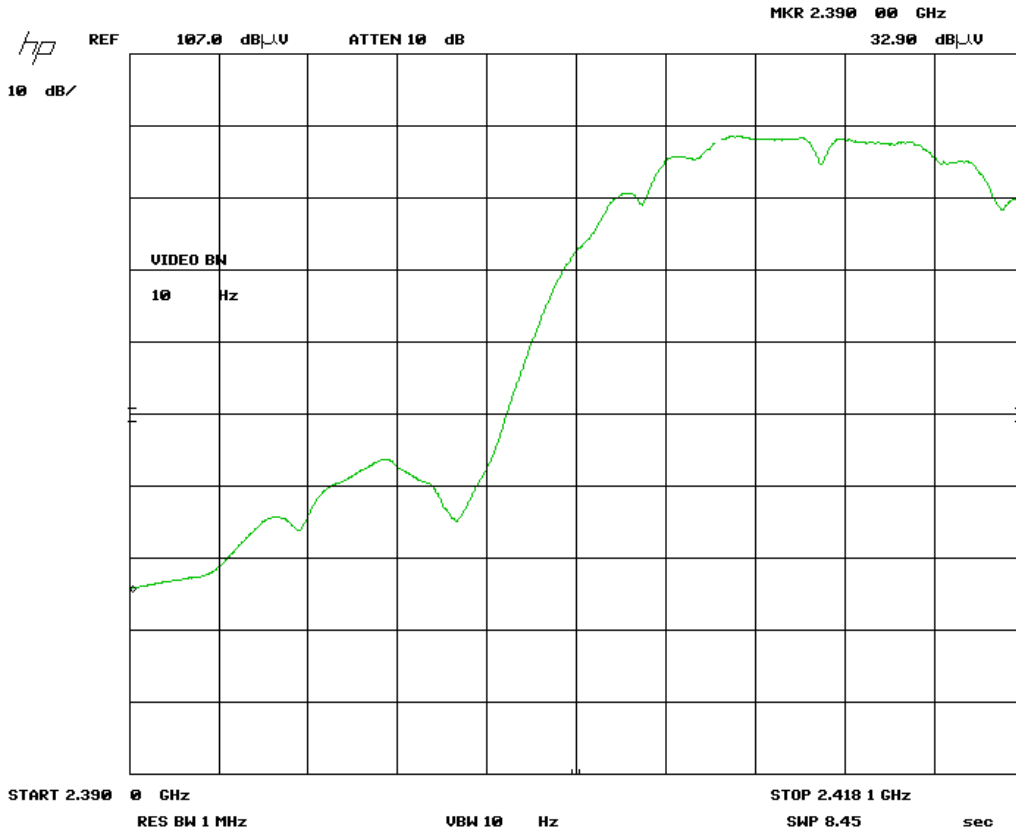

Note: Bandedge plots were taken with 3 m measurements distance. The marker shows the raw value; see Final Measurements and Results section for corrected values.

Client	Ecobee Inc	
Product	WEM01	
Standard(s)	RSS 210 Issue 8:2010 / FCC Part 15 Subpart C 15:2014	

B Protocol, Band Edge – Hi Channel
Vertical - Peak Emission

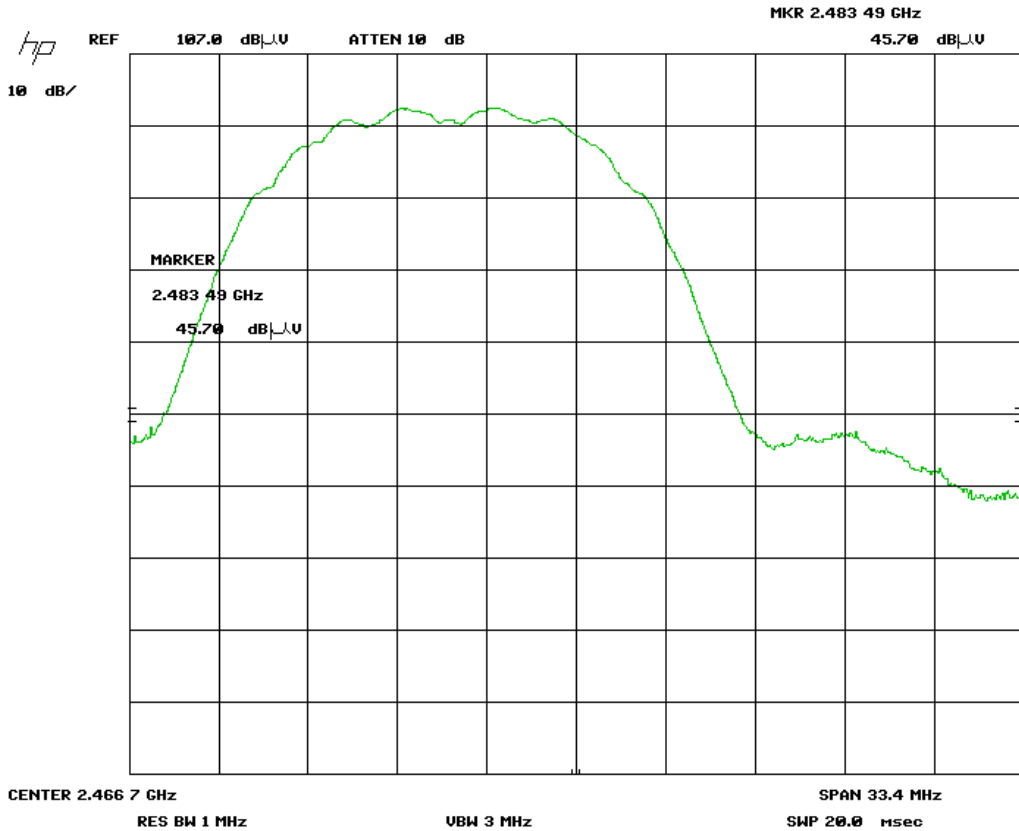

Note: Bandedge plots were taken with 3 m measurements distance. The marker shows the raw value; see Final Measurements and Results section for corrected values.

Client	Ecobee Inc	
Product	WEM01	
Standard(s)	RSS 210 Issue 8:2010 / FCC Part 15 Subpart C 15:2014	

**B Protocol, Band Edge – Hi Channel
Horizontal - Peak Emission**

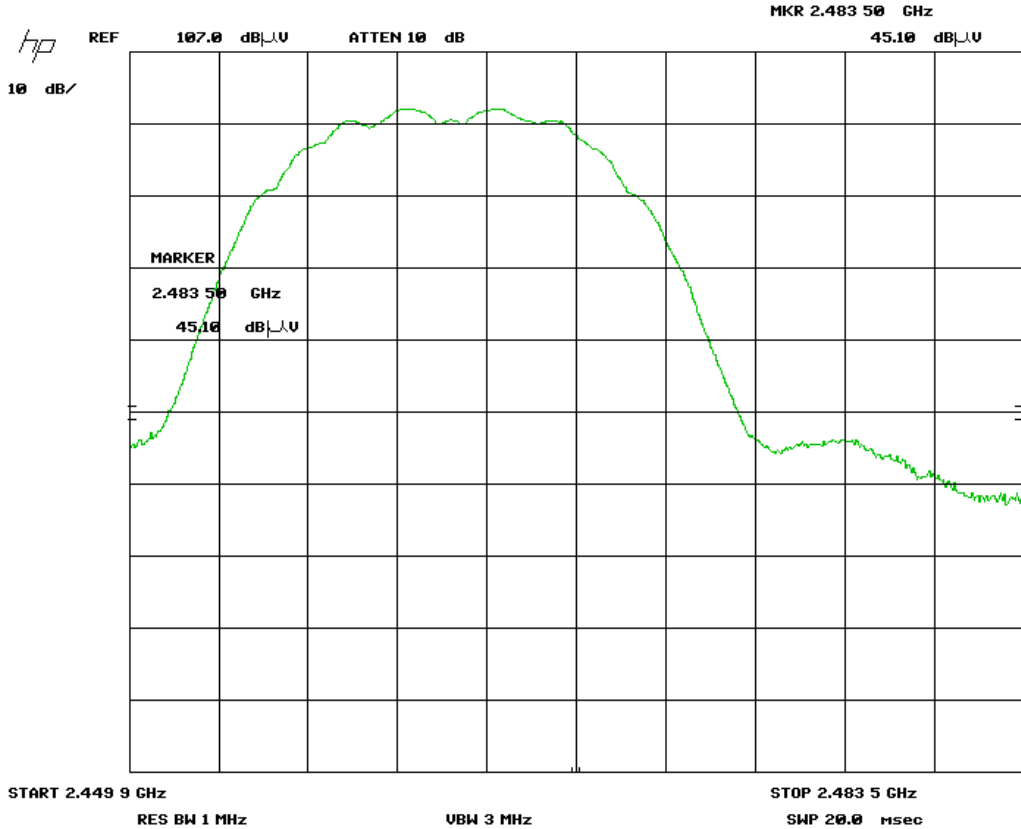

Note: Bandedge plots were taken with 3 m measurements distance. The marker shows the raw value; see Final Measurements and Results section for corrected values.

Client	Ecobee Inc	
Product	WEM01	
Standard(s)	RSS 210 Issue 8:2010 / FCC Part 15 Subpart C 15:2014	

**B Protocol, Band Edge – Hi Channel
Vertical - Average Emission**

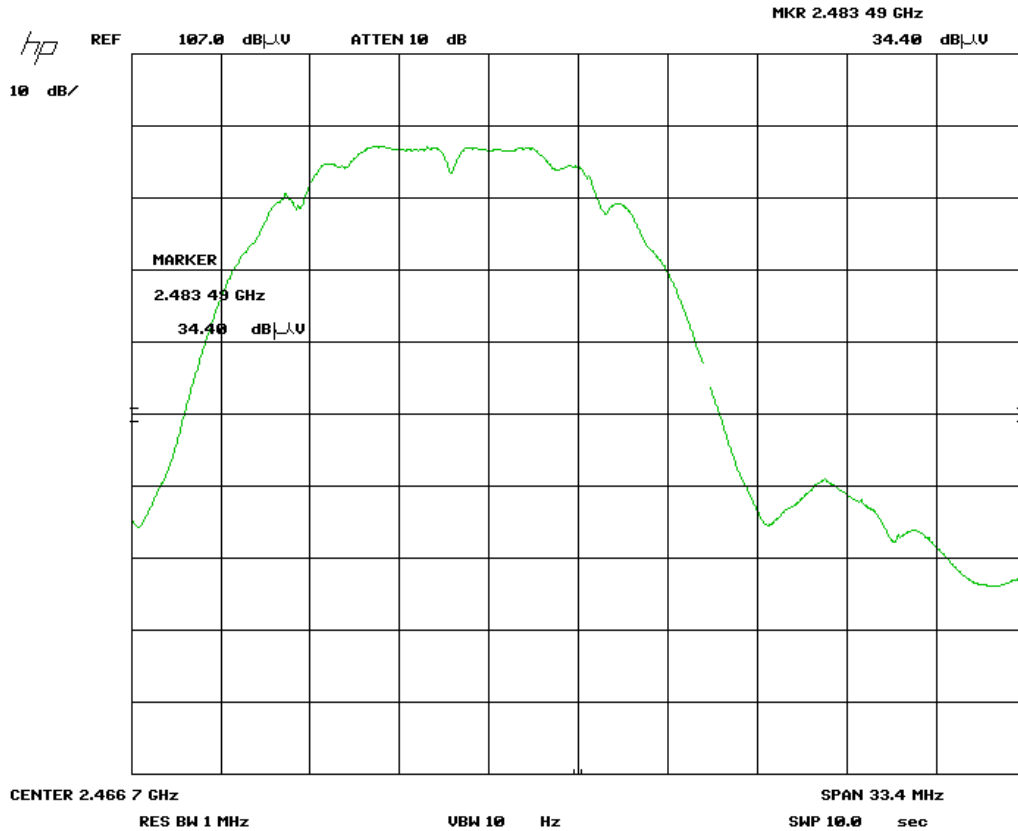

Note: Bandedge plots were taken with 3 m measurements distance. The marker shows the raw value; see Final Measurements and Results section for corrected values.

Client	Ecobee Inc	
Product	WEM01	
Standard(s)	RSS 210 Issue 8:2010 / FCC Part 15 Subpart C 15:2014	

**B Protocol, Band Edge – Hi Channel
Horizontal - Average Emission**

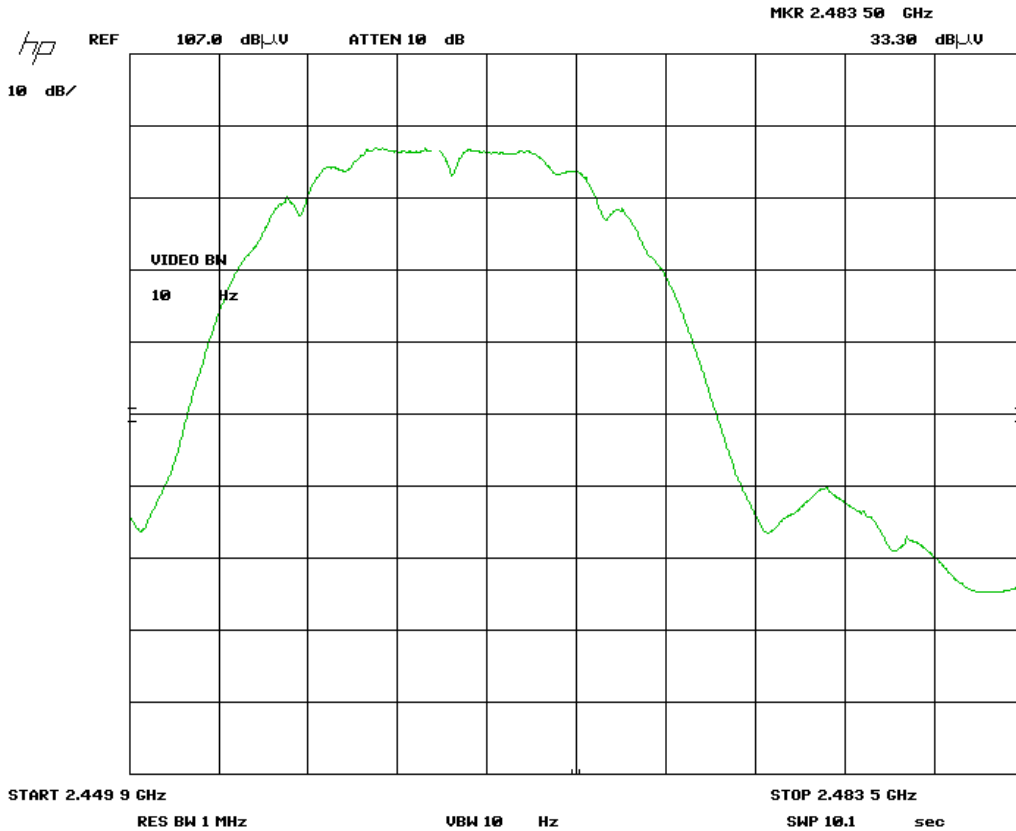

Note: Bandedge plots were taken with 3 m measurements distance. The marker shows the raw value; see Final Measurements and Results section for corrected values.

Client	Ecobee Inc	
Product	WEM01	
Standard(s)	RSS 210 Issue 8:2010 / FCC Part 15 Subpart C 15:2014	

G Protocol, Band Edge – Low Channel
Vertical - Peak Emission

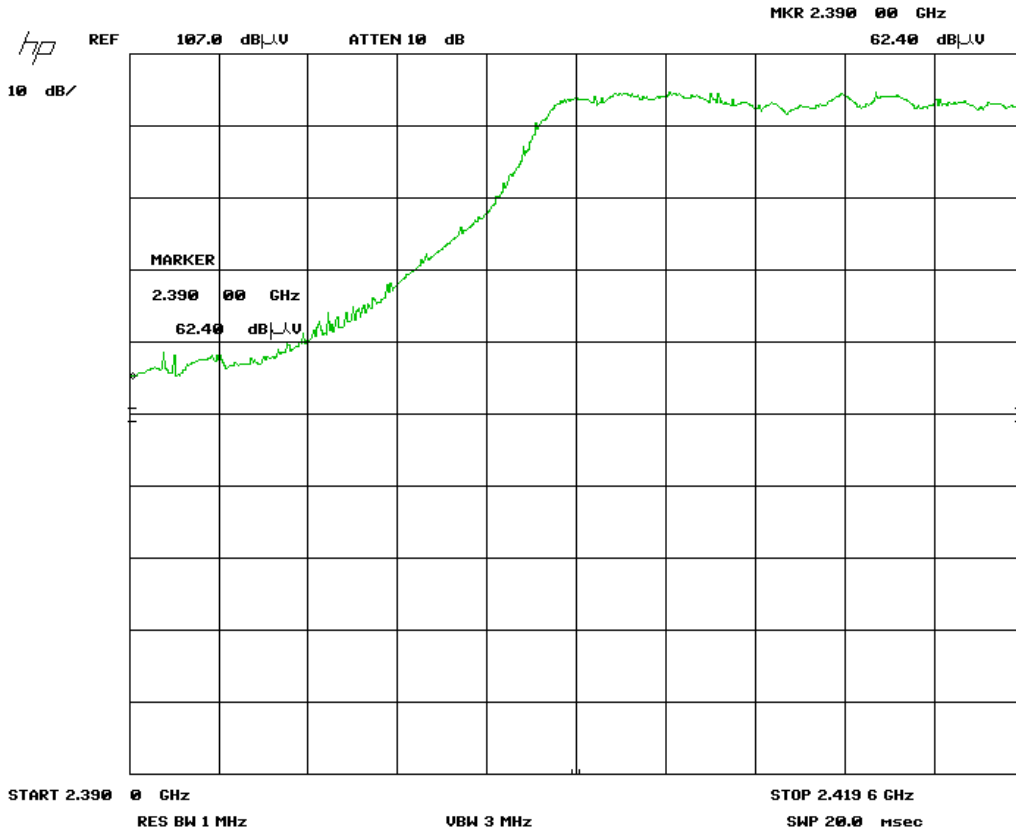

Note: Bandedge plots were taken with 3 m measurements distance. The marker shows the raw value; see Final Measurements and Results section for corrected values.

Client	Ecobee Inc	
Product	WEM01	
Standard(s)	RSS 210 Issue 8:2010 / FCC Part 15 Subpart C 15:2014	

G Protocol, Band Edge – Low Channel
Horizontal - Peak Emission

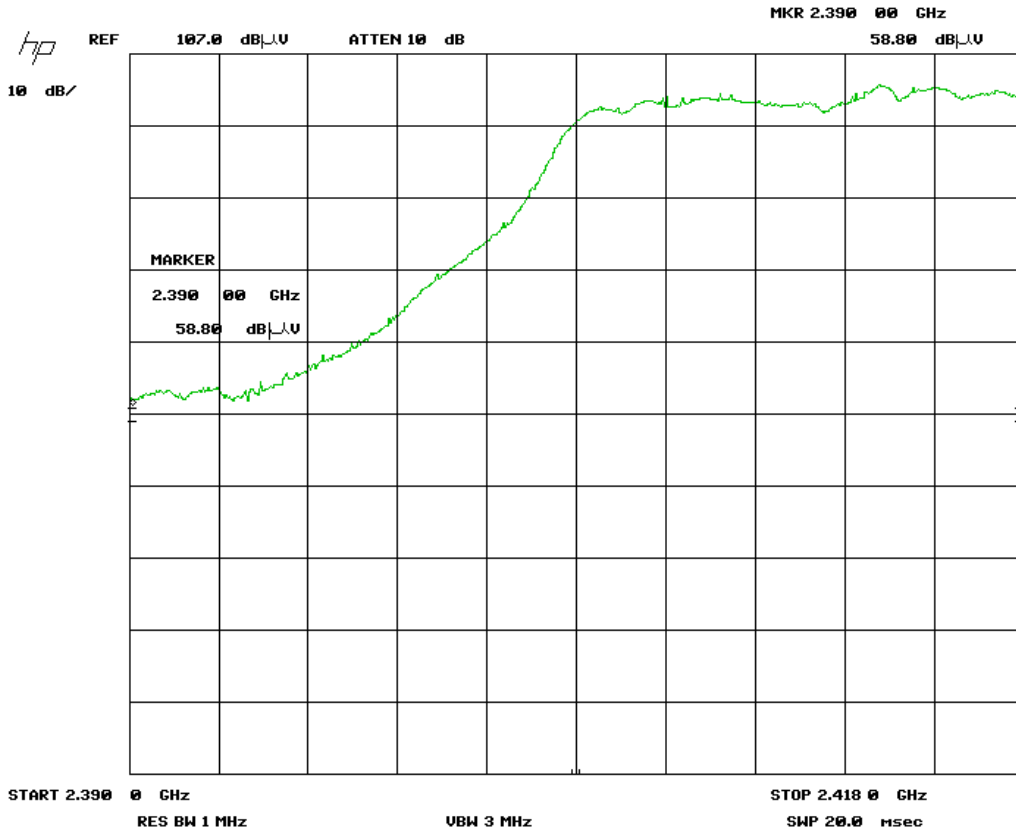

Note: Bandedge plots were taken with 3 m measurements distance. The marker shows the raw value; see Final Measurements and Results section for corrected values.

Client	Ecobee Inc	
Product	WEM01	
Standard(s)	RSS 210 Issue 8:2010 / FCC Part 15 Subpart C 15:2014	

G Protocol, Band Edge – Low Channel
Vertical – Average Emission

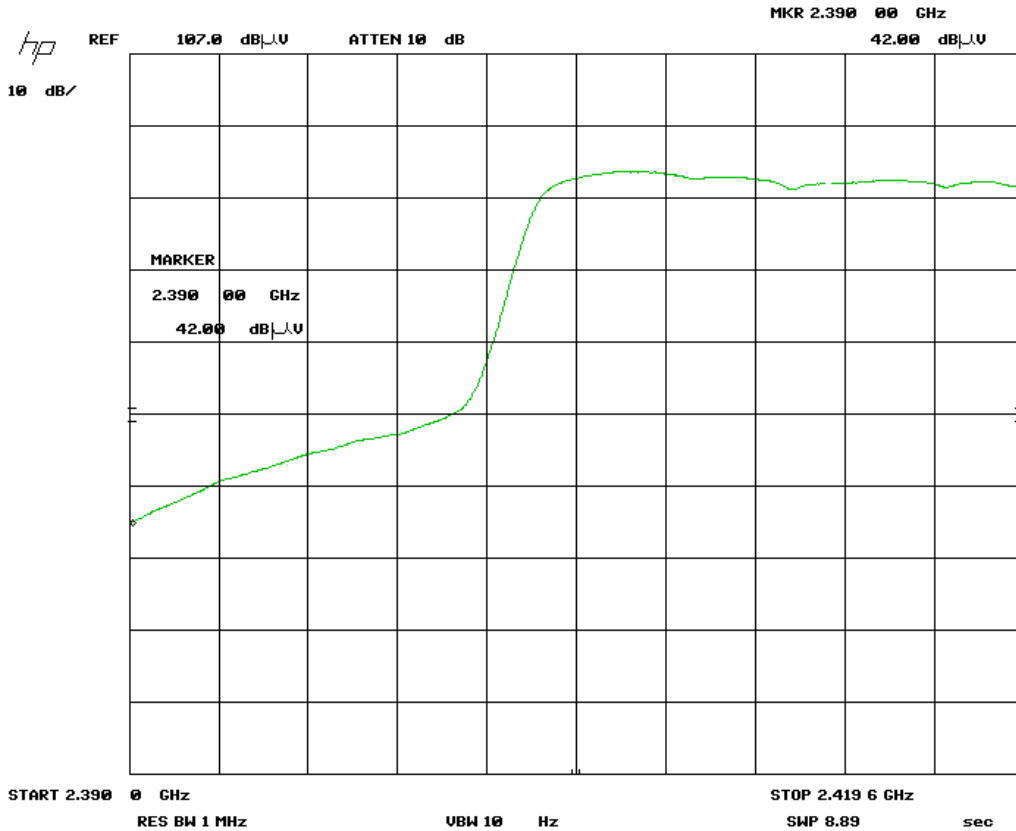

Note: Bandedge plots were taken with 3 m measurements distance. The marker shows the raw value; see Final Measurements and Results section for corrected values.

Client	Ecobee Inc	
Product	WEM01	
Standard(s)	RSS 210 Issue 8:2010 / FCC Part 15 Subpart C 15:2014	

G Protocol, Band Edge – Low Channel
Horizontal - Average Emission

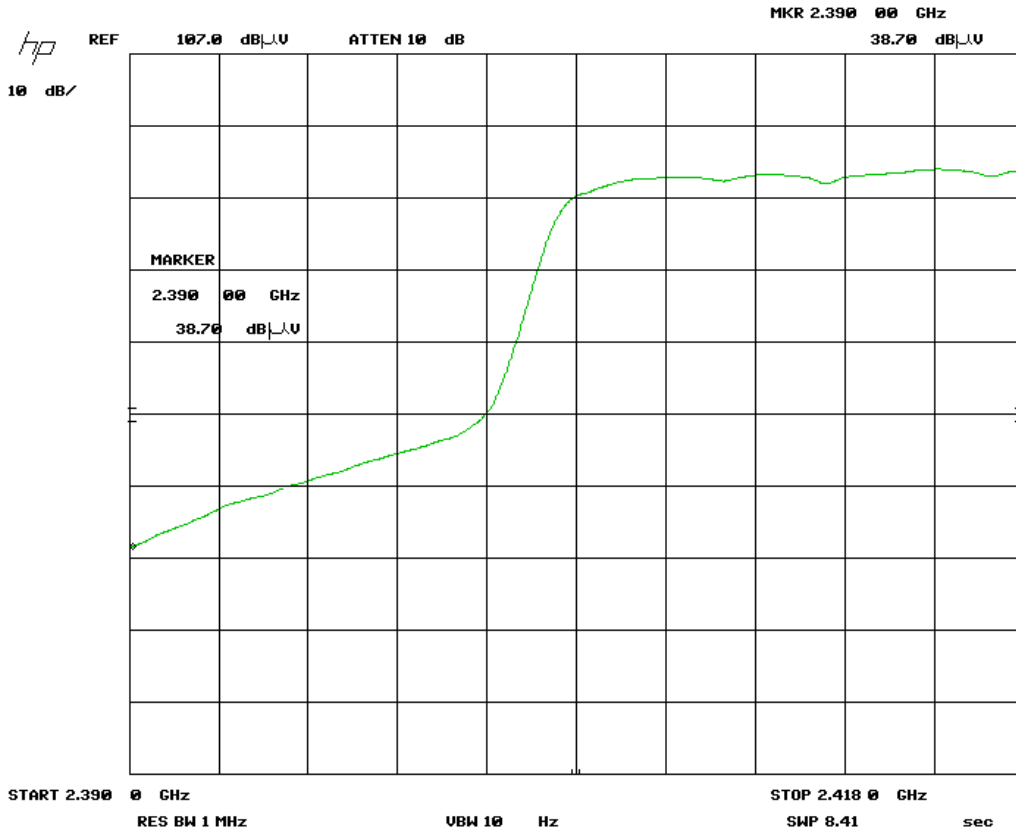

Note: Bandedge plots were taken with 3 m measurements distance. The marker shows the raw value; see Final Measurements and Results section for corrected values.

Client	Ecobee Inc	
Product	WEM01	
Standard(s)	RSS 210 Issue 8:2010 / FCC Part 15 Subpart C 15:2014	

**G Protocol, Band Edge – Hi Channel
Vertical - Peak Emission**

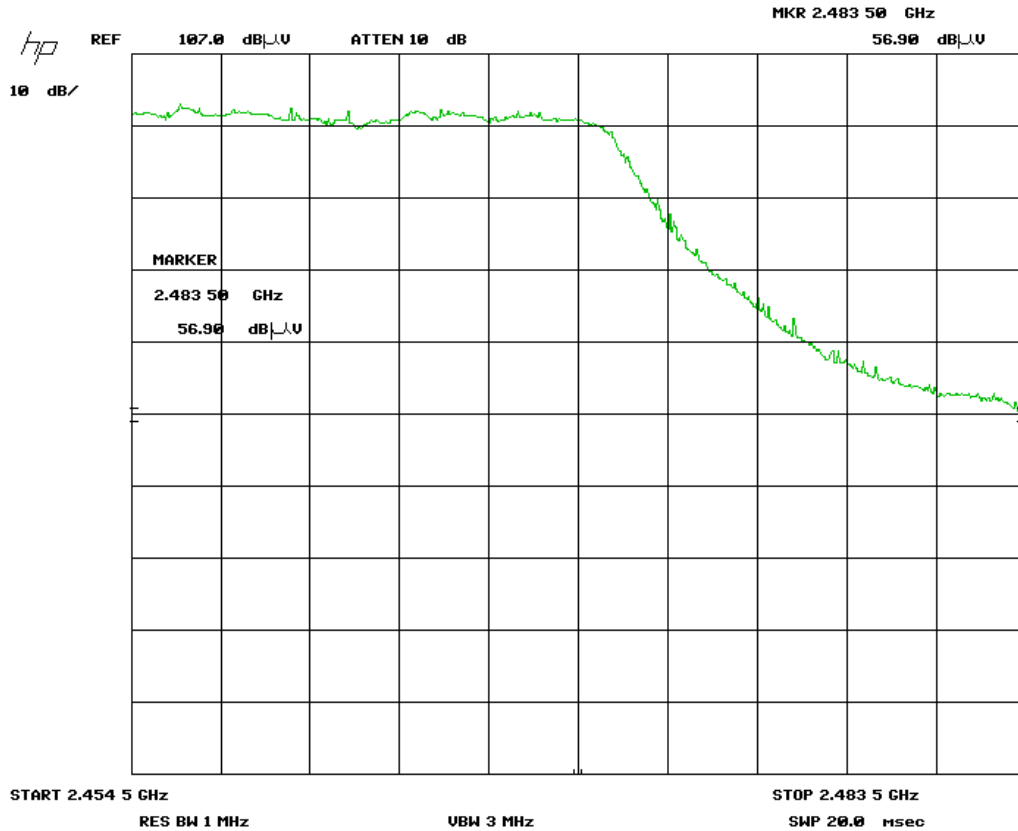

Note: Bandedge plots were taken with 3 m measurements distance. The marker shows the raw value; see Final Measurements and Results section for corrected values.

Client	Ecobee Inc	
Product	WEM01	
Standard(s)	RSS 210 Issue 8:2010 / FCC Part 15 Subpart C 15:2014	

G Protocol, Band Edge – Hi Channel
Horizontal - Peak Emission

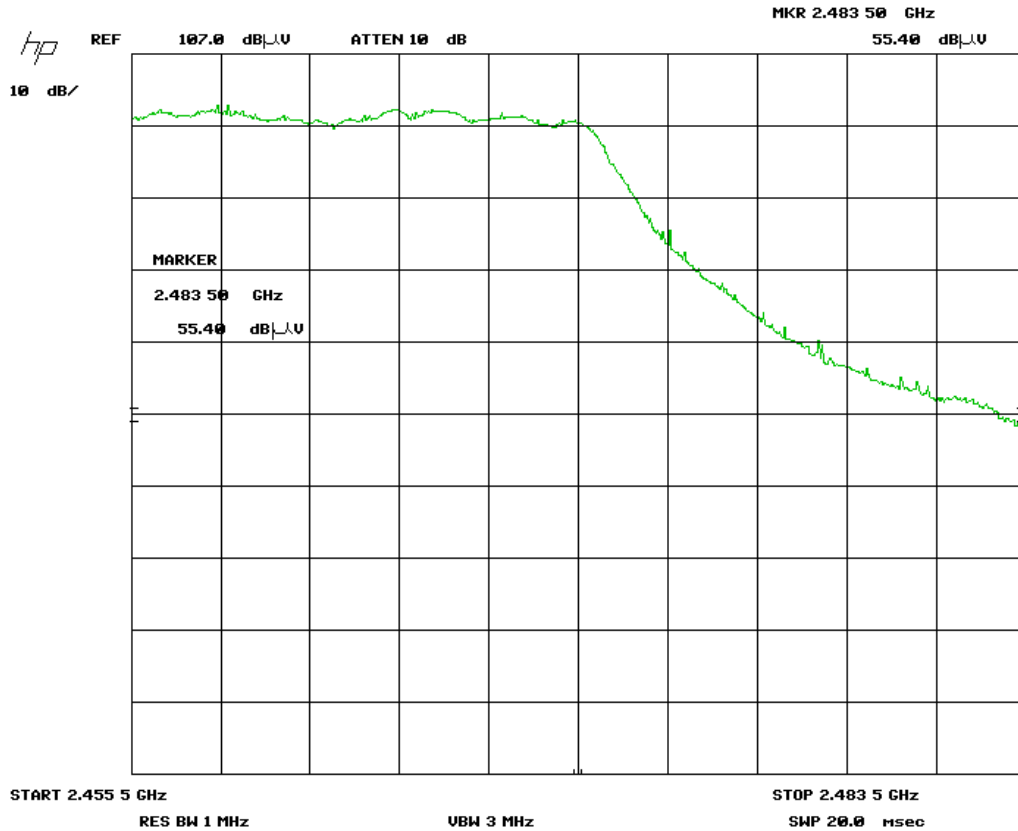

Note: Bandedge plots were taken with 3 m measurements distance. The marker shows the raw value; see Final Measurements and Results section for corrected values.

Client	Ecobee Inc	
Product	WEM01	
Standard(s)	RSS 210 Issue 8:2010 / FCC Part 15 Subpart C 15:2014	

G Protocol, Band Edge – Hi Channel
Vertical - Average Emission

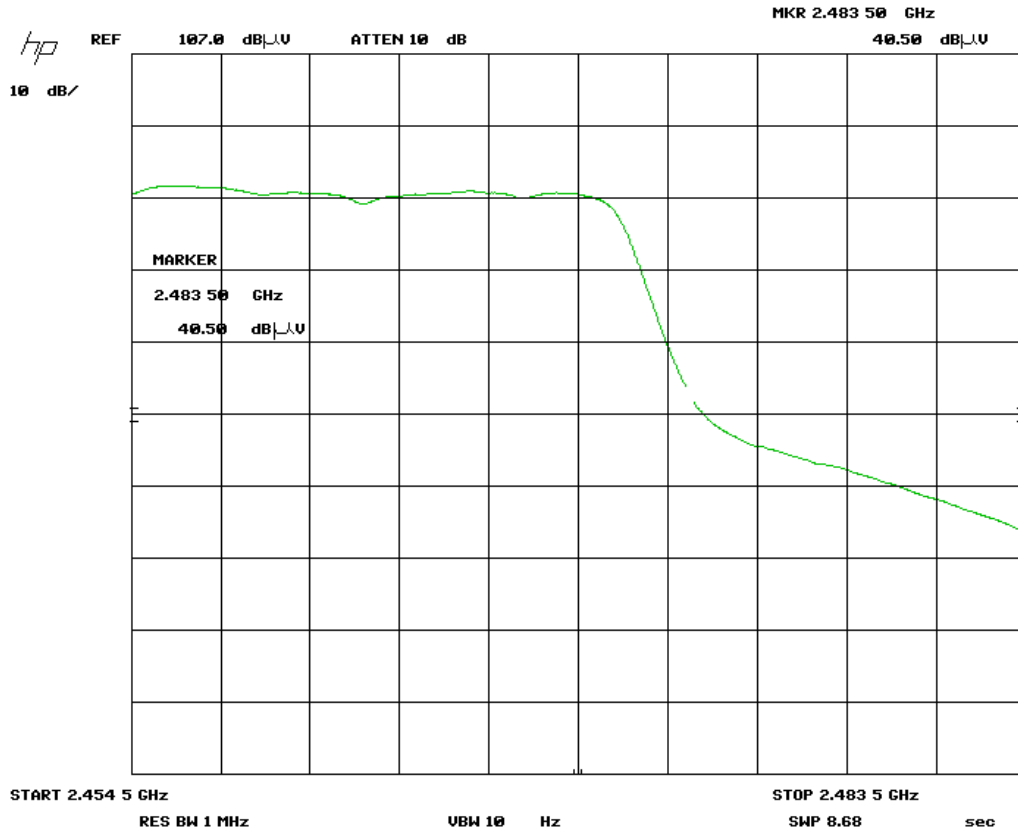

Note: Bandedge plots were taken with 3 m measurements distance. The marker shows the raw value; see Final Measurements and Results section for corrected values.

Client	Ecobee Inc	
Product	WEM01	
Standard(s)	RSS 210 Issue 8:2010 / FCC Part 15 Subpart C 15:2014	

**G Protocol, Band Edge – Hi Channel
Horizontal - Average Emission**

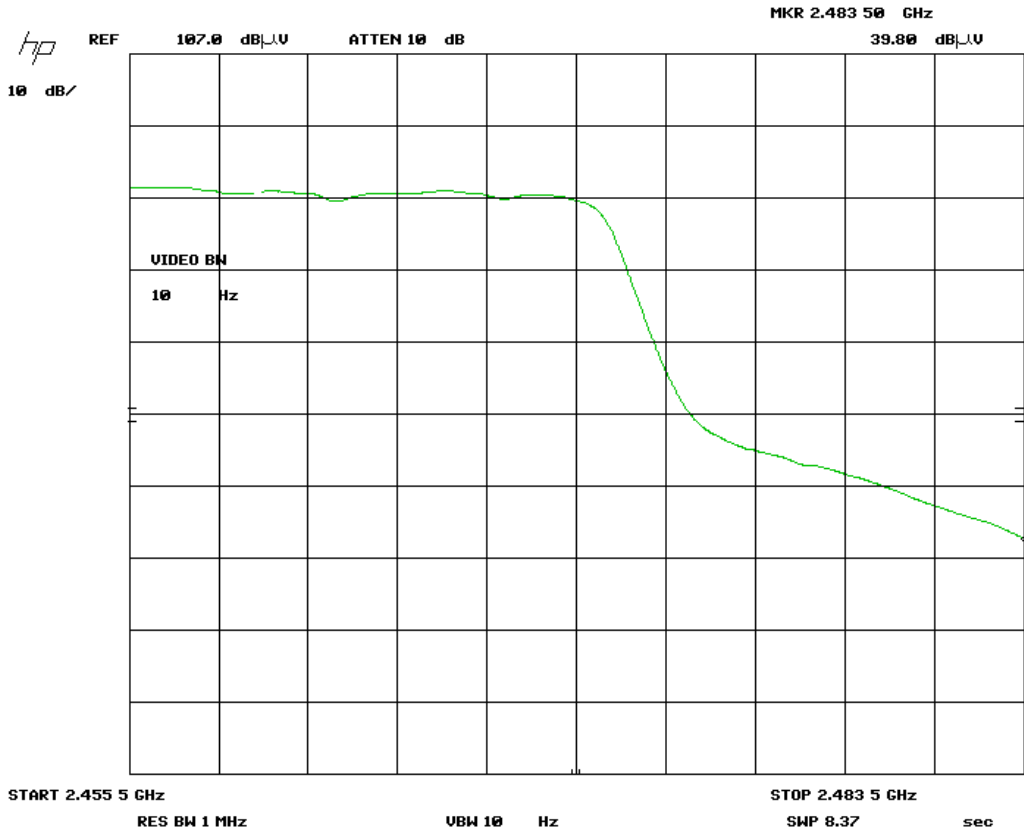

Note: Bandedge plots were taken with 3 m measurements distance. The marker shows the raw value; see Final Measurements and Results section for corrected values.

Client	Ecobee Inc	
Product	WEM01	
Standard(s)	RSS 210 Issue 8:2010 / FCC Part 15 Subpart C 15:2014	

N Protocol, Band Edge – Low Channel
Vertical - Peak Emission

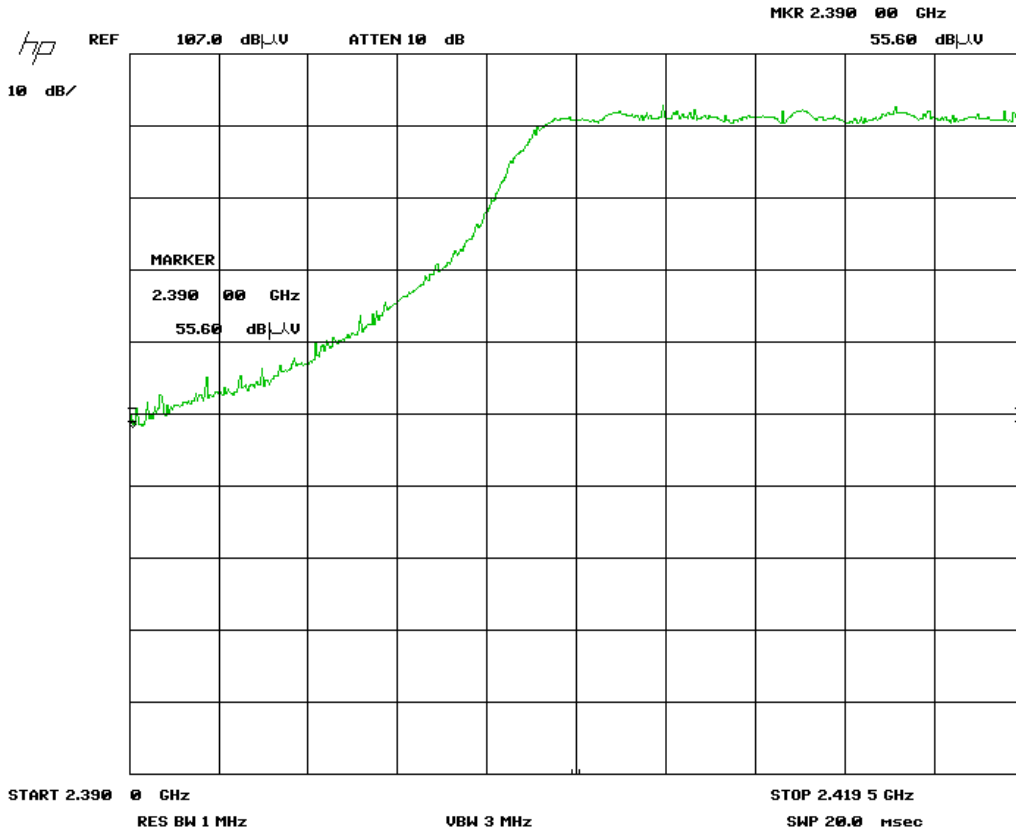

Note: Bandedge plots were taken with 3 m measurements distance. The marker shows the raw value; see Final Measurements and Results section for corrected values.

Client	Ecobee Inc	
Product	WEM01	
Standard(s)	RSS 210 Issue 8:2010 / FCC Part 15 Subpart C 15:2014	

N Protocol, Band Edge – Low Channel
Horizontal - Peak Emission

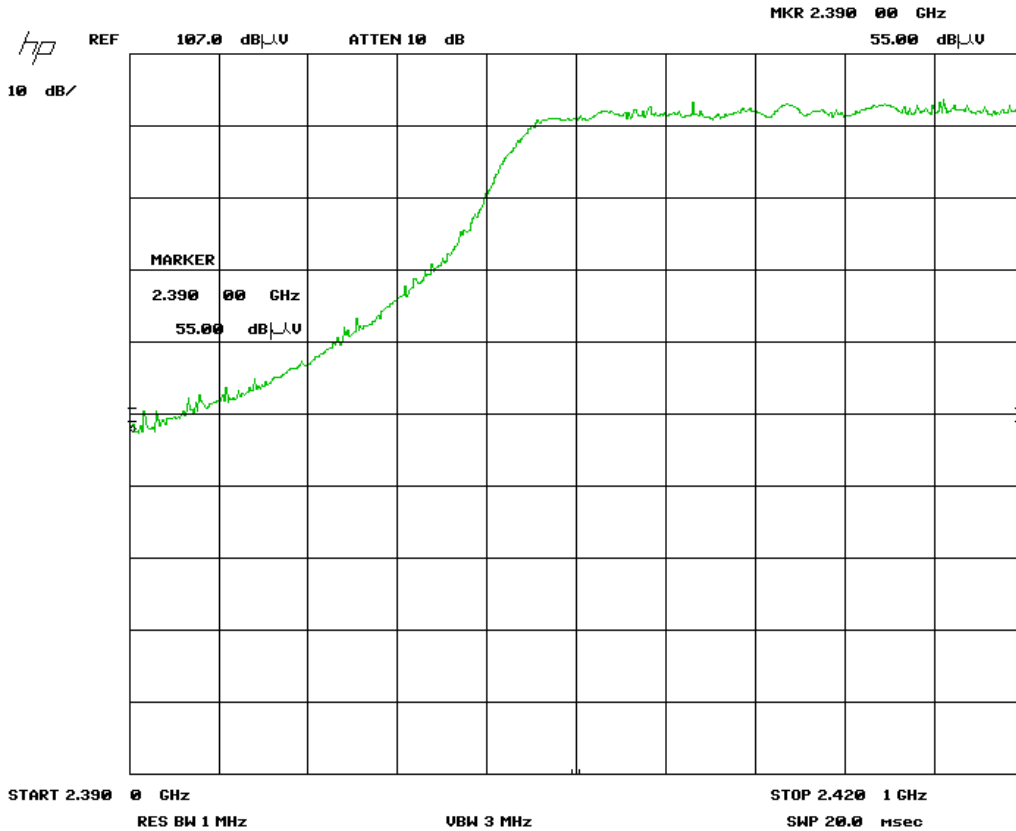

Note: Bandedge plots were taken with 3 m measurements distance. The marker shows the raw value; see Final Measurements and Results section for corrected values.

Client	Ecobee Inc	
Product	WEM01	
Standard(s)	RSS 210 Issue 8:2010 / FCC Part 15 Subpart C 15:2014	

N Protocol, Band Edge – Low Channel
Vertical – Average Emission

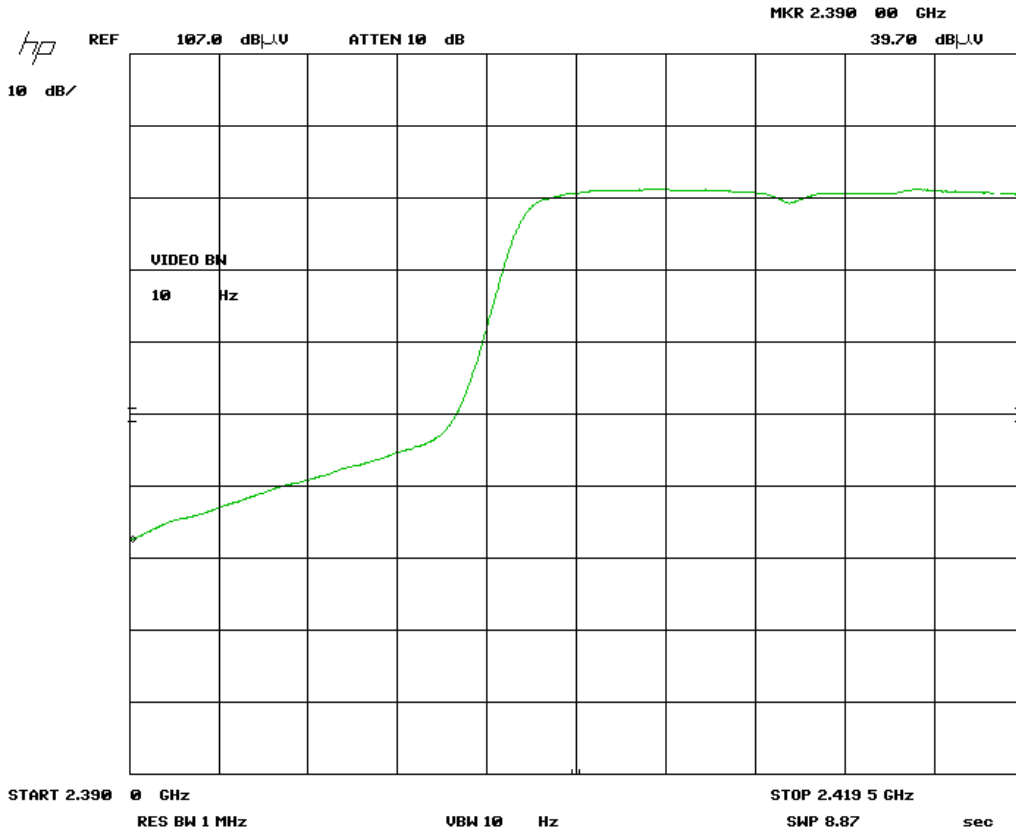

Note: Bandedge plots were taken with 3 m measurements distance. The marker shows the raw value; see Final Measurements and Results section for corrected values.

Client	Ecobee Inc	
Product	WEM01	
Standard(s)	RSS 210 Issue 8:2010 / FCC Part 15 Subpart C 15:2014	

N Protocol, Band Edge – Low Channel
Horizontal - Average Emission

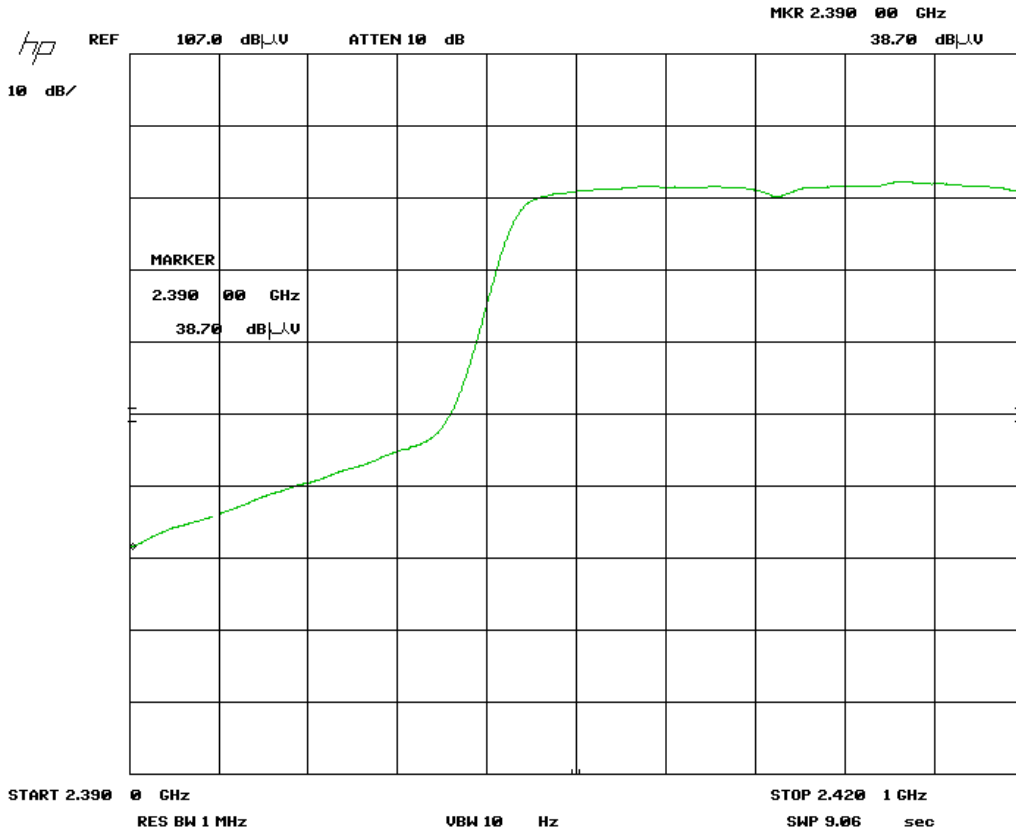

Note: Bandedge plots were taken with 3 m measurements distance. The marker shows the raw value; see Final Measurements and Results section for corrected values.

Client	Ecobee Inc	
Product	WEM01	
Standard(s)	RSS 210 Issue 8:2010 / FCC Part 15 Subpart C 15:2014	

N Protocol, Band Edge – Hi Channel
Vertical - Peak Emission

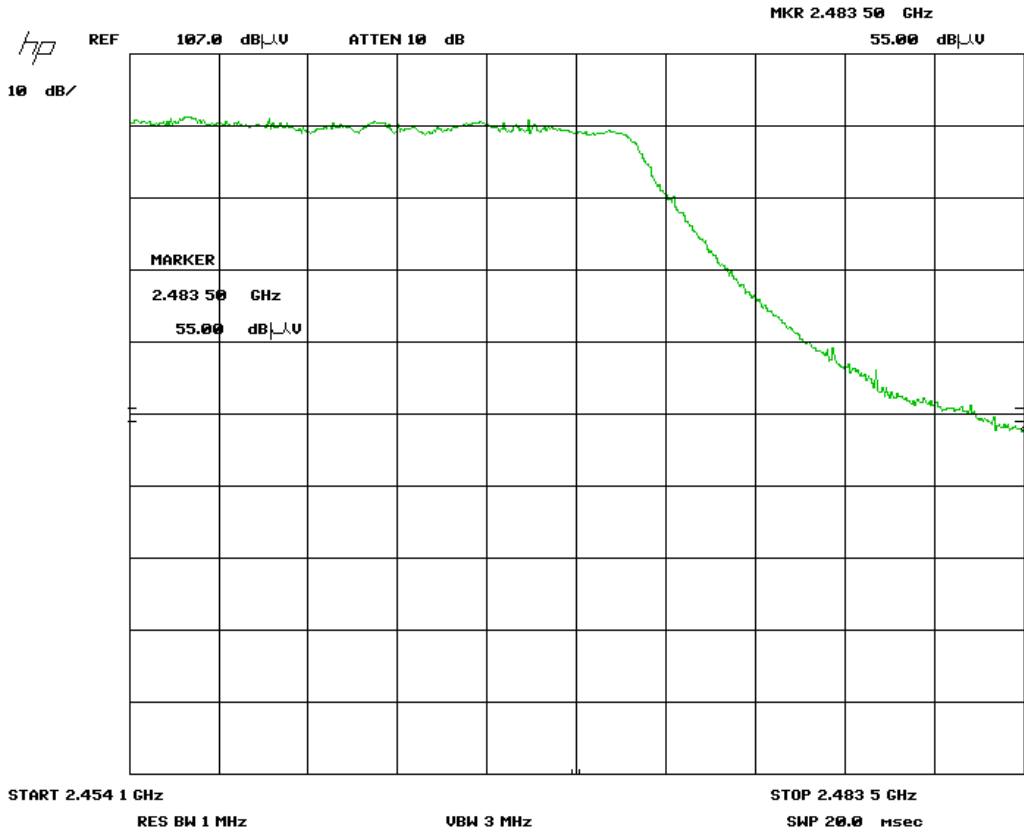

Note: Bandedge plots were taken with 3 m measurements distance. The marker shows the raw value; see Final Measurements and Results section for corrected values.

Client	Ecobee Inc	
Product	WEM01	
Standard(s)	RSS 210 Issue 8:2010 / FCC Part 15 Subpart C 15:2014	

N Protocol, Band Edge – Hi Channel
Horizontal - Peak Emission

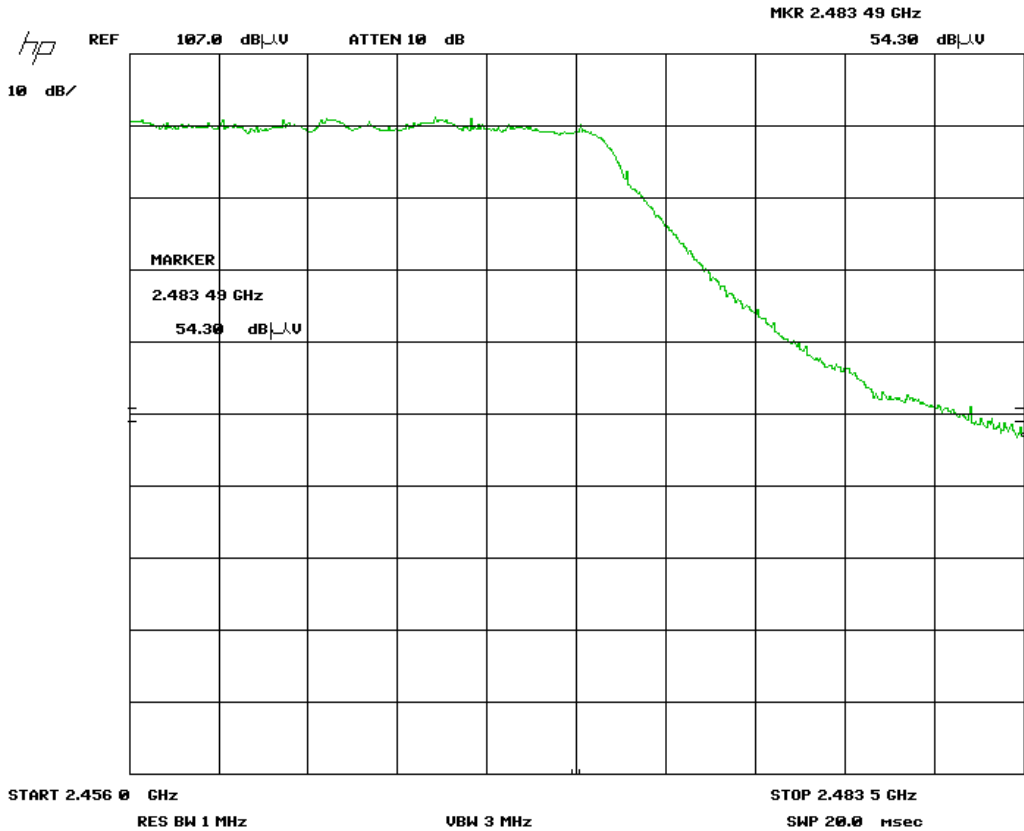

Note: Bandedge plots were taken with 3 m measurements distance. The marker shows the raw value; see Final Measurements and Results section for corrected values.

Client	Ecobee Inc	
Product	WEM01	
Standard(s)	RSS 210 Issue 8:2010 / FCC Part 15 Subpart C 15:2014	

N Protocol, Band Edge – Hi Channel
Vertical - Average Emission

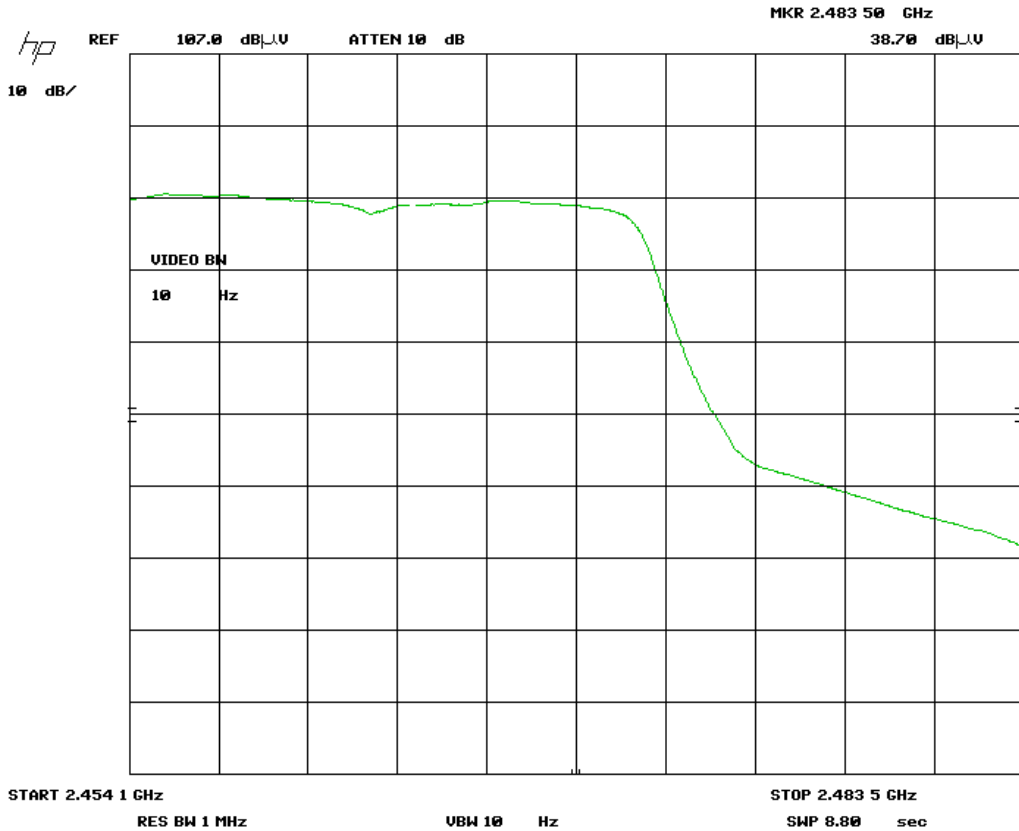

Note: Bandedge plots were taken with 3 m measurements distance. The marker shows the raw value; see Final Measurements and Results section for corrected values.

Client	Ecobee Inc	
Product	WEM01	
Standard(s)	RSS 210 Issue 8:2010 / FCC Part 15 Subpart C 15:2014	

N Protocol, Band Edge – Hi Channel
Horizontal - Average Emission

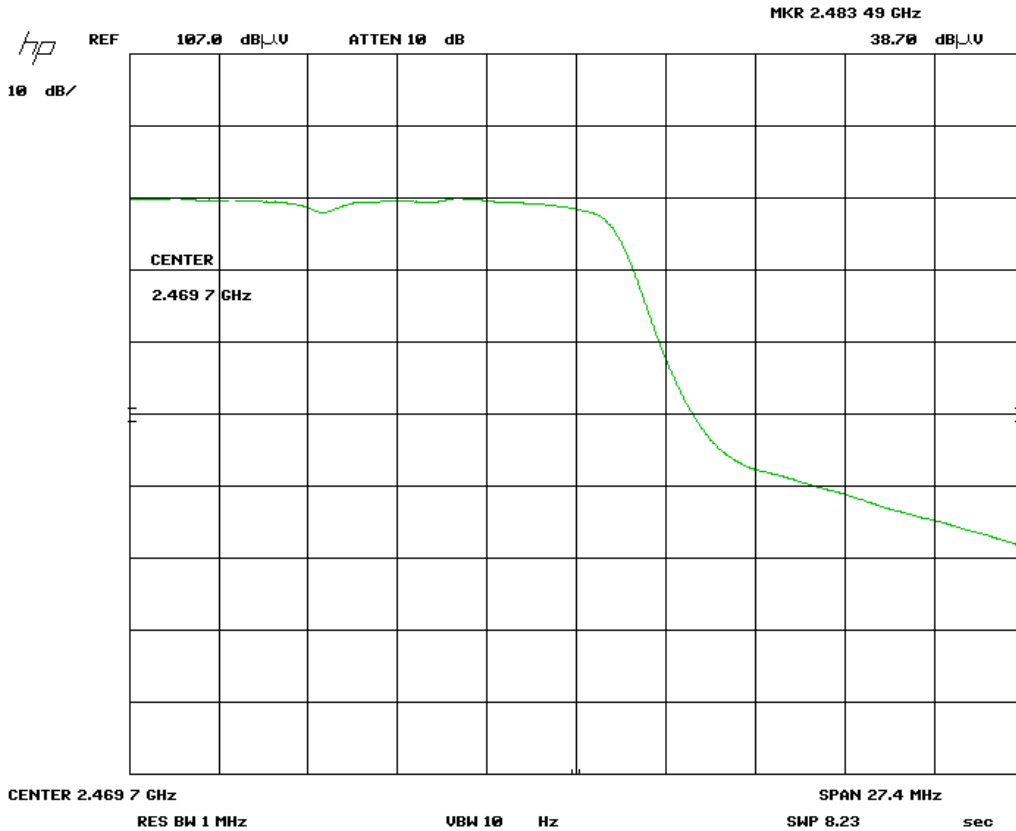

Note: Bandedge plots were taken with 3 m measurements distance. The marker shows the raw value; see Final Measurements and Results section for corrected values.

Client	Ecobee Inc	
Product	WEM01	
Standard(s)	RSS 210 Issue 8:2010 / FCC Part 15 Subpart C 15:2014	

Final Measurements and Results

The EUT passed the limits. B, G and N Protocols are measured; and for each Protocol, Low, middle and high bands were measured.

In accordance with 15.247(d), only frequencies exceeding the 15.209 limit that occur within the bands listed in 15.205, need to be verified with a final detector.

For frequency shown on the peak graphs and not listed in 15.205, measurements were taken for reference.

The measurements were maximized by rotating the turn table over a full 0-360 rotation and the antenna height was varied from 1 m to 4 m.

Loop Antenna							
Frequency (MHz)	Detector	Raw (dBuV)	Factors	Level (dBuV)	Limit (dB)	Margin (dB)	Pass/Fail
0.6475	QP	43.1	20.4	63.5	71.4	7.9	Pass
Vertical Emission Table							
498.704	QP	44.4	-9.6	34.8	46.4	11.6	Pass
1598.67	AVG	38.6	-5.6	33	54	21	Pass
Horizontal Emission Table							
498.704	QP	46.6	-9.1	37.5	46.4	8.9	Pass
1597	AVG	37.7	-4.1	33.6	54	20.4	Pass

Client	Ecobee Inc	
Product	WEM01	
Standard(s)	RSS 210 Issue 8:2010 / FCC Part 15 Subpart C 15:2014	

B-Protocol												
Test Frequency (MHz)	Detection mode	Antenna polarity (Horz/Vert)	Raw signal dB(µV)	Antenna factor dB	Cable			Pre-Amp Gain dB	Received signal dB(µV/m)	Emission limit dB(µV/m)	Margin dB(µV)	Result
					loss dB + ecor	Attenuator dB	Presel					
Low Channel (1) - Z axis (Flat)												
2412	Peak	Horz	100.5	30.8	5.4	0.0	35.8	100.9				PASS
2412	Avg	Horz	95.1	30.8	5.4	0.0	35.8	95.5				PASS
2412	Peak	Vert	98.4	30.8	5.4	0.0	35.8	98.8				PASS
2412	Avg	Vert	93.0	30.8	5.4	0.0	35.8	93.4				PASS
2390	Peak	Horz	43.8	30.8	5.4	0.0	35.8	44.2	74.0	29.8		PASS
2390	Avg	Horz	31.7	30.8	5.4	0.0	35.8	32.1	54.0	21.9		PASS
2390	Peak	Vert	43.9	30.8	5.4	0.0	35.8	44.3	74.0	29.7		PASS
2390	Avg	Vert	32.2	30.8	5.4	0.0	35.8	32.6	54.0	21.4		PASS
Low Channel (1) - X axis (Horizontal)												
2412	Peak	Horz	92.6	30.8	5.4	0.0	35.8	93.0				PASS
2412	Avg	Horz	87.0	30.8	5.4	0.0	35.8	87.4				PASS
2412	Peak	Vert	96.6	30.8	5.4	0.0	35.8	97.0				PASS
2412	Avg	Vert	91.4	30.8	5.4	0.0	35.8	91.8				PASS
2390	Peak	Horz	42.1	30.8	5.4	0.0	35.8	42.5	74.0	31.5		PASS
2390	Avg	Horz	30.3	30.8	5.4	0.0	35.8	30.7	54.0	23.3		PASS
2390	Peak	Vert	43.9	30.8	5.4	0.0	35.8	44.3	74.0	29.7		PASS
2390	Avg	Vert	31.7	30.8	5.4	0.0	35.8	32.1	54.0	21.9		PASS
Low Channel (1) - Y axis (Vertical)												
2412	Peak	Horz	101.2	30.8	5.4	0.0	35.8	101.6				PASS
2412	Avg	Horz	95.6	30.8	5.4	0.0	35.8	96.0				PASS
2412	Peak	Vert	101.0	30.8	5.4	0.0	35.8	101.4				PASS
2412	Avg	Vert	95.4	30.8	5.4	0.0	35.8	95.8				PASS
2390	Peak	Horz	45.6	30.8	5.4	0.0	35.8	46.0	74.0	28.0		PASS
2390	Avg	Horz	32.9	30.8	5.4	0.0	35.8	33.3	54.0	20.7		PASS
2390	Peak	Vert	45.3	30.8	5.4	0.0	35.8	45.7	74.0	28.3		PASS
2390	Avg	Vert	33.2	30.8	5.4	0.0	35.8	33.6	54.0	20.4		PASS
4824	Peak	Horz	48.6	30.6	7.7	0.0	35.2	51.7	74.0	22.3		PASS
4824	Avg	Horz	43.1	30.6	7.7	0.0	35.2	46.2	54.0	7.8		PASS
4824	Peak	Vert	48.0	30.6	7.7	0.0	35.2	51.1	74.0	22.9		PASS
4824	Avg	Vert	42.7	30.6	7.7	0.0	35.2	45.8	54.0	8.2		PASS
7236	Peak	Horz	46.6	33.5	9.6	0.0	35.6	54.1	74.0	19.9		PASS
7236	Avg	Horz	33.4	33.5	9.6	0.0	35.6	40.9	54.0	13.1		PASS
7236	Peak	Vert	46.0	33.5	9.6	0.0	35.6	53.5	74.0	20.5		PASS
7236	Avg	Vert	33.3	33.5	9.6	0.0	35.6	40.8	54.0	13.2		PASS
9648	Peak	Horz	46.9	38.6	9.6	0.0	36.1	59.0	74.0	15.0		PASS
9648	Avg	Horz	33.5	38.6	9.6	0.0	36.1	45.6	54.0	8.4		PASS
9648	Peak	Vert	47.3	38.6	9.6	0.0	36.1	59.4	74.0	14.6		PASS
9648	Avg	Vert	33.5	38.6	9.6	0.0	36.1	45.6	54.0	8.4		PASS

Client	Ecobee Inc	
Product	WEM01	
Standard(s)	RSS 210 Issue 8:2010 / FCC Part 15 Subpart C 15:2014	

B-Protocol											
Test Frequency (MHz)	Detection mode	Antenna polarity (Horz/Vert)	Raw signal dB(µV)	Antenna factor dB	Cable			Received signal dB(µV/m)	Emission limit dB(µV/m)	Margin dB(µV)	Result
					loss dB + Preselector	Attenuator dB	Pre-Amp Gain dB				
Mid Channel (6) - Z axis (Flat)											
2437	Peak	Horz	98.2	30.8	5.4	0.0	35.8	98.6			PASS
2437	Avg	Horz	93.2	30.8	5.4	0.0	35.8	93.6			PASS
2437	Peak	Vert	97.8	30.8	5.4	0.0	35.8	98.2			PASS
2437	Avg	Vert	92.5	30.8	5.4	0.0	35.8	92.9			PASS
Mid Channel (6) - X axis (Horizontal)											
2437	Peak	Horz	93.2	30.8	5.4	0.0	35.8	93.6			PASS
2437	Avg	Horz	87.8	30.8	5.4	0.0	35.8	88.2			PASS
2437	Peak	Vert	97.4	30.8	5.4	0.0	35.8	97.8			PASS
2437	Avg	Vert	92.1	30.8	5.4	0.0	35.8	92.5			PASS
Mid Channel (6) - Y axis (Vertical)											
2437	Peak	Horz	99.5	30.8	5.4	0.0	35.8	99.9			PASS
2437	Avg	Horz	94.4	30.8	5.4	0.0	35.8	94.8			PASS
2437	Peak	Vert	101.4	30.8	5.4	0.0	35.8	101.8			PASS
2437	Avg	Vert	96.0	30.8	5.4	0.0	35.8	96.4			PASS
4874	Peak	Horz	47.9	30.6	7.7	0.0	35.2	51.0	74.0	23.0	PASS
4874	Avg	Horz	41.3	30.6	7.7	0.0	35.2	44.4	54.0	9.6	PASS
4874	Peak	Vert	50.1	30.6	7.7	0.0	35.2	53.2	74.0	20.8	PASS
4874	Avg	Vert	45.5	30.6	7.7	0.0	35.2	48.6	54.0	5.4	PASS
7311	Peak	Vert	46.8	33.5	9.6	0.0	35.6	54.3	74.0	19.7	PASS
7311	Avg	Vert	33.4	33.5	9.6	0.0	35.6	40.9	54.0	13.1	PASS
7311	Peak	Horz	46.0	33.5	9.6	0.0	35.6	53.5	74.0	20.5	PASS
7311	Avg	Horz	32.6	33.5	9.6	0.0	35.6	40.1	54.0	13.9	PASS
9748	Peak	Horz	46.2	38.6	9.6	0.0	36.1	58.3	74.0	15.7	PASS
9748	Avg	Horz	32.8	38.6	9.6	0.0	36.1	44.9	54.0	9.1	PASS
9748	Peak	Vert	46.1	38.6	9.6	0.0	36.1	58.2	74.0	15.8	PASS
9748	Avg	Vert	32.9	38.6	9.6	0.0	36.1	45.0	54.0	9.0	PASS

Client	Ecobee Inc	
Product	WEM01	
Standard(s)	RSS 210 Issue 8:2010 / FCC Part 15 Subpart C 15:2014	

B-Protocol											
Test Frequency (MHz)	Detection mode	Antenna polarity (Horz/Vert)	Raw signal dB(µV)	Antenna factor dB	Cable		Pre-Amp Gain dB	Received signal dB(µV/m)	Emission limit dB(µV/m)	Margin dB(µV)	Result
					loss dB + ecor	Attenuator dB					
High Channel (11) - Z axis (Flat)											
2462	Peak	Horz	98.6	30.8	5.4	0.0	35.8	99.0			PASS
2462	Avg	Horz	93.4	30.8	5.4	0.0	35.8	93.8			PASS
2462	Peak	Vert	95.2	30.8	5.4	0.0	35.8	95.6			PASS
2462	Avg	Vert	90.0	30.8	5.4	0.0	35.8	90.4			PASS
2483.5	Peak	Horz	44.9	30.8	5.4	0.0	35.8	45.3	74.0	28.7	PASS
2483.5	Avg	Horz	33.7	30.8	5.4	0.0	35.8	34.1	54.0	19.9	PASS
2483.5	Peak	Vert	44.2	30.8	5.4	0.0	35.8	44.6	74.0	29.4	PASS
2483.5	Avg	Vert	31.7	30.8	5.4	0.0	35.8	32.1	54.0	21.9	PASS
High Channel (11) - X axis (Horizontal)											
2462	Peak	Horz	89.8	30.8	5.4	0.0	35.8	90.2			PASS
2462	Avg	Horz	84.9	30.8	5.4	0.0	35.8	85.3			PASS
2462	Peak	Vert	97.6	30.8	5.4	0.0	35.8	98.0			PASS
2462	Avg	Vert	92.5	30.8	5.4	0.0	35.8	92.9			PASS
2483.5	Peak	Horz	42.8	30.8	5.4	0.0	35.8	43.2	74.0	30.8	PASS
2483.5	Avg	Horz	30.4	30.8	5.4	0.0	35.8	30.8	54.0	23.2	PASS
2483.5	Peak	Vert	44.5	30.8	5.4	0.0	35.8	44.9	74.0	29.1	PASS
2483.5	Avg	Vert	32.8	30.8	5.4	0.0	35.8	33.2	54.0	20.8	PASS
High Channel (11) - Y axis (Vertical)											
2462	Peak	Horz	99.4	30.8	5.4	0.0	35.8	99.8			PASS
2462	Avg	Horz	94.2	30.8	5.4	0.0	35.8	94.6			PASS
2462	Peak	Vert	99.5	30.8	5.4	0.0	35.8	99.9			PASS
2462	Avg	Vert	94.3	30.8	5.4	0.0	35.8	94.7			PASS
2483.5	Peak	Horz	45.1	30.8	5.4	0.0	35.8	45.5	74.0	28.5	PASS
2483.5	Avg	Horz	33.3	30.8	5.4	0.0	35.8	33.7	54.0	20.3	PASS
2483.5	Peak	Vert	45.5	30.8	5.4	0.0	35.8	45.9	74.0	28.1	PASS
2483.5	Avg	Vert	34.4	30.8	5.4	0.0	35.8	34.8	54.0	19.2	PASS
4924	Peak	Horz	45.0	33.5	7.7	0.0	35.2	51.0	74.0	23.0	PASS
4924	Avg	Horz	36.1	33.5	7.7	0.0	35.2	42.1	54.0	11.9	PASS
4924	Peak	Vert	45.9	33.5	7.7	0.0	35.2	51.9	74.0	22.1	PASS
4924	Avg	Vert	37.9	33.5	7.7	0.0	35.2	43.9	54.0	10.1	PASS
7386	Peak	Vert	46.6	38.6	9.6	0.0	35.6	59.2	74.0	14.8	PASS
7386	Avg	Vert	31.9	38.6	9.6	0.0	35.6	44.5	54.0	9.5	PASS
7386	Peak	Horz	45.9	38.6	9.6	0.0	35.6	58.5	74.0	15.5	PASS
7386	Avg	Horz	32.0	38.6	9.6	0.0	35.6	44.6	54.0	9.4	PASS
9848	Peak	Horz	46.0	40.1	9.6	0.0	36.1	59.6	74.0	14.4	PASS
9848	Avg	Horz	32.9	40.1	9.6	0.0	36.1	46.5	54.0	7.5	PASS
9848	Peak	Vert	47.2	40.1	9.6	0.0	36.1	60.8	74.0	13.2	PASS
9848	Avg	Vert	32.9	40.1	9.6	0.0	36.1	46.5	54.0	7.5	PASS

Client	Ecobee Inc	
Product	WEM01	
Standard(s)	RSS 210 Issue 8:2010 / FCC Part 15 Subpart C 15:2014	

G-Protocol												
Test Frequency (MHz)	Detection mode	Antenna polarity (Horz/Vert)	Raw signal dB(µV)	Antenna factor dB	Cable			Pre-Amp Gain dB	Received signal dB(µV/m)	Emission limit dB(µV/m)	Margin dB(µV)	Result
					loss dB + ecor	Attenuator dB	Presel					
Low Channel (1) - Z axis (Flat)												
2412	Peak	Horz	101.6	30.8	5.4	0.0	35.8	102.0				PASS
2412	Avg	Horz	89.7	30.8	5.4	0.0	35.8	90.1				PASS
2412	Peak	Vert	99.3	30.8	5.4	0.0	35.8	99.7				PASS
2412	Avg	Vert	87.6	30.8	5.4	0.0	35.8	88.0				PASS
2390	Peak	Horz	58.7	30.8	5.4	0.0	35.8	59.1	74.0	14.9		PASS
2390	Avg	Horz	40.5	30.8	5.4	0.0	35.8	40.9	54.0	13.1		PASS
2390	Peak	Vert	56.9	30.8	5.4	0.0	35.8	57.3	74.0	16.7		PASS
2390	Avg	Vert	38.7	30.8	5.4	0.0	35.8	39.1	54.0	14.9		PASS
Low Channel (1) - X axis (Horizontal)												
2412	Peak	Horz	95.1	30.8	5.4	0.0	35.8	95.5				PASS
2412	Avg	Horz	83.3	30.8	5.4	0.0	35.8	83.7				PASS
2412	Peak	Vert	99.5	30.8	5.4	0.0	35.8	99.9				PASS
2412	Avg	Vert	88.2	30.8	5.4	0.0	35.8	88.6				PASS
2390	Peak	Horz	51.1	30.8	5.4	0.0	35.8	51.5	74.0	22.5		PASS
2390	Avg	Horz	34.1	30.8	5.4	0.0	35.8	34.5	54.0	19.5		PASS
2390	Peak	Vert	58.8	30.8	5.4	0.0	35.8	59.2	74.0	14.8		PASS
2390	Avg	Vert	39.0	30.8	5.4	0.0	35.8	39.4	54.0	14.6		PASS
Low Channel (1) - Y axis (Vertical)												
2412	Peak	Horz	104.0	30.8	5.4	0.0	35.8	104.4				PASS
2412	Avg	Horz	90.8	30.8	5.4	0.0	35.8	91.2				PASS
2412	Peak	Vert	102.1	30.8	5.4	0.0	35.8	102.5				PASS
2412	Avg	Vert	90.7	30.8	5.4	0.0	35.8	91.1				PASS
2390	Peak	Horz	58.8	30.8	5.4	0.0	35.8	59.2	74.0	14.8		PASS
2390	Avg	Horz	38.7	30.8	5.4	0.0	35.8	39.1	54.0	14.9		PASS
2390	Peak	Vert	62.4	30.8	5.4	0.0	35.8	62.8	74.0	11.2		PASS
2390	Avg	Vert	42.0	30.8	5.4	0.0	35.8	42.4	54.0	11.6		PASS
4824	Peak	Horz	48.9	30.6	7.7	0.0	35.2	52.0	74.0	22.0		PASS
4824	Avg	Horz	33.8	30.6	7.7	0.0	35.2	36.9	54.0	17.1		PASS
4824	Peak	Vert	47.5	30.6	7.7	0.0	35.2	50.6	74.0	23.4		PASS
4824	Avg	Vert	32.4	30.6	7.7	0.0	35.2	35.5	54.0	18.5		PASS
7236	Peak	Horz	46.2	33.5	9.6	0.0	35.6	53.7	74.0	20.3		PASS
7236	Avg	Horz	32.8	33.5	9.6	0.0	35.6	40.3	54.0	13.7		PASS
7236	Peak	Vert	46.7	33.5	9.6	0.0	35.6	54.2	74.0	19.8		PASS
7236	Avg	Vert	32.7	33.5	9.6	0.0	35.6	40.2	54.0	13.8		PASS
9648	Peak	Horz	47.4	38.6	9.6	0.0	36.1	59.5	74.0	14.5		PASS
9648	Avg	Horz	33.5	38.6	9.6	0.0	36.1	45.6	54.0	8.4		PASS
9648	Peak	Vert	47.5	38.6	9.6	0.0	36.1	59.6	74.0	14.4		PASS
9648	Avg	Vert	33.6	38.6	9.6	0.0	36.1	45.7	54.0	8.3		PASS

Client	Ecobee Inc	
Product	WEM01	
Standard(s)	RSS 210 Issue 8:2010 / FCC Part 15 Subpart C 15:2014	

G-Protocol												
Test Frequency (MHz)	Detection mode	Antenna polarity (Horz/Vert)	Raw signal dB(µV)	Antenna factor dB	Cable			Pre-Amp Gain dB	Received signal dB(µV/m)	Emission limit dB(µV/m)	Margin dB(µV)	Result
					loss dB + Preselector	Attenuator dB	Attenuator dB					
Mid Channel (6) - Z axis (Flat)												
2437	Peak	Horz	101.2	30.8	5.4	0.0	35.8	101.6				PASS
2437	Avg	Horz	89.5	30.8	5.4	0.0	35.8	89.9				PASS
2437	Peak	Vert	98.9	30.8	5.4	0.0	35.8	99.3				PASS
2437	Avg	Vert	87.6	30.8	5.4	0.0	35.8	88.0				PASS
Mid Channel (6) - X axis (Horizontal)												
2437	Peak	Horz	97.2	30.8	5.4	0.0	35.8	97.6				PASS
2437	Avg	Horz	85.9	30.8	5.4	0.0	35.8	86.3				PASS
2437	Peak	Vert	99.7	30.8	5.4	0.0	35.8	100.1				PASS
2437	Avg	Vert	88.1	30.8	5.4	0.0	35.8	88.5				PASS
Mid Channel (6) - Y axis (Vertical)												
2437	Peak	Horz	104.3	30.8	5.4	0.0	35.8	104.7				PASS
2437	Avg	Horz	92.1	30.8	5.4	0.0	35.8	92.5				PASS
2437	Peak	Vert	103.6	30.8	5.4	0.0	35.8	104.0				PASS
2437	Avg	Vert	91.5	30.8	5.4	0.0	35.8	91.9				PASS
4874	Peak	Horz	52.2	30.6	7.7	0.0	35.2	55.3	74.0	18.7		PASS
4874	Avg	Horz	36.7	30.6	7.7	0.0	35.2	39.8	54.0	14.2		PASS
4874	Peak	Vert	50.8	30.6	7.7	0.0	35.2	53.9	74.0	20.1		PASS
4874	Avg	Vert	35.3	30.6	7.7	0.0	35.2	38.4	54.0	15.6		PASS
7311	Peak	Vert	47.1	33.5	9.6	0.0	35.6	54.6	74.0	19.4		PASS
7311	Avg	Vert	32.9	33.5	9.6	0.0	35.6	40.4	54.0	13.6		PASS
7311	Peak	Horz	46.3	33.5	9.6	0.0	35.6	53.8	74.0	20.2		PASS
7311	Avg	Horz	33.0	33.5	9.6	0.0	35.6	40.5	54.0	13.5		PASS
9748	Peak	Horz	46.6	38.6	9.6	0.0	36.1	58.7	74.0	15.3		PASS
9748	Avg	Horz	33.0	38.6	9.6	0.0	36.1	45.1	54.0	8.9		PASS
9748	Peak	Vert	47.0	38.6	9.6	0.0	36.1	59.1	74.0	14.9		PASS
9748	Avg	Vert	33.1	38.6	9.6	0.0	36.1	45.2	54.0	8.8		PASS

Client	Ecobee Inc	
Product	WEM01	
Standard(s)	RSS 210 Issue 8:2010 / FCC Part 15 Subpart C 15:2014	

h

G-Protocol											
Test Frequency (MHz)	Detection mode	Antenna polarity (Horz/Vert)	Raw signal dB(µV)	Antenna factor dB	Cable loss dB + Preselector	Attenuator dB	Pre-Amp Gain dB	Received signal dB(µV/m)	Emission limit dB(µV/m)	Margin dB(µV)	Result
High Channel (11) - Z axis (Flat)											
2462	Peak	Horz	101.3	30.8	5.4	0.0	35.8	101.7			PASS
2462	Avg	Horz	88.9	30.8	5.4	0.0	35.8	89.3			PASS
2462	Peak	Vert	97.5	30.8	5.4	0.0	35.8	97.9			PASS
2462	Avg	Vert	85.6	30.8	5.4	0.0	35.8	86.0			PASS
2483.5	Peak	Horz	58.8	30.8	5.4	0.0	35.8	59.2	74.0	14.8	PASS
2483.5	Avg	Horz	42.3	30.8	5.4	0.0	35.8	42.7	54.0	11.3	PASS
2483.5	Peak	Vert	52.4	30.8	5.4	0.0	35.8	52.8	74.0	21.2	PASS
2483.5	Avg	Vert	36.9	30.8	5.4	0.0	35.8	37.3	54.0	16.7	PASS
High Channel (11) - X axis (Horizontal)											
2462	Peak	Horz	98.3	30.8	5.4	0.0	35.8	98.7			PASS
2462	Avg	Horz	84.6	30.8	5.4	0.0	35.8	85.0			PASS
2462	Peak	Vert	100.3	30.8	5.4	0.0	35.8	100.7			PASS
2462	Avg	Vert	88.8	30.8	5.4	0.0	35.8	89.2			PASS
2483.5	Peak	Horz	53.8	30.8	5.4	0.0	35.8	54.2	74.0	19.8	PASS
2483.5	Avg	Horz	38.9	30.8	5.4	0.0	35.8	39.3	54.0	14.7	PASS
2483.5	Peak	Vert	56.2	30.8	5.4	0.0	35.8	56.6	74.0	17.4	PASS
2483.5	Avg	Vert	40.5	30.8	5.4	0.0	35.8	40.9	54.0	13.1	PASS
High Channel (11) - Y axis (Vertical)											
2462	Peak	Horz	99.9	30.8	5.4	0.0	35.8	100.3			PASS
2462	Avg	Horz	88.6	30.8	5.4	0.0	35.8	89.0			PASS
2462	Peak	Vert	101.0	30.8	5.4	0.0	35.8	101.4			PASS
2462	Avg	Vert	88.8	30.8	5.4	0.0	35.8	89.2			PASS
2483.5	Peak	Horz	55.4	30.8	5.4	0.0	35.8	55.8	74.0	18.2	PASS
2483.5	Avg	Horz	39.8	30.8	5.4	0.0	35.8	40.2	54.0	13.8	PASS
2483.5	Peak	Vert	56.9	30.8	5.4	0.0	35.8	57.3	74.0	16.7	PASS
2483.5	Avg	Vert	40.5	30.8	5.4	0.0	35.8	40.9	54.0	13.1	PASS
4924	Peak	Horz	46.1	33.5	7.7	0.0	35.2	52.1	74.0	21.9	PASS
4924	Avg	Horz	31.8	33.5	5.4	0.0	35.2	35.5	54.0	18.5	PASS
4924	Peak	Vert	45.9	33.5	5.4	0.0	35.2	49.6	74.0	24.4	PASS
4924	Avg	Vert	31.3	33.5	5.4	0.0	35.2	35.0	54.0	19.0	PASS
7386	Peak	Vert	45.9	38.6	9.6	0.0	35.6	58.5	74.0	15.5	PASS
7386	Avg	Vert	32.2	38.6	9.6	0.0	35.6	44.8	54.0	9.2	PASS
7386	Peak	Horz	46.2	38.6	9.6	0.0	35.6	58.8	74.0	15.2	PASS
7386	Avg	Horz	32.4	38.6	9.6	0.0	35.6	45.0	54.0	9.0	PASS
9848	Peak	Horz	46.8	40.1	9.6	0.0	36.1	60.4	74.0	13.6	PASS
9848	Avg	Horz	33.1	40.1	9.6	0.0	36.1	46.7	54.0	7.3	PASS
9848	Peak	Vert	46.5	40.1	9.6	0.0	36.1	60.1	74.0	13.9	PASS
9848	Avg	Vert	32.9	40.1	9.6	0.0	36.1	46.5	54.0	7.5	PASS

Client	Ecobee Inc	
Product	WEM01	
Standard(s)	RSS 210 Issue 8:2010 / FCC Part 15 Subpart C 15:2014	

N-Protocol												
Test Frequency (MHz)	Detection mode	Antenna polarity (Horz/Vert)	Raw signal dB(µV)	Antenna factor dB	Cable			Pre-Amp Gain dB	Received signal dB(µV/m)	Emission limit dB(µV/m)	Margin dB(µV)	Result
					loss dB + ecor	Attenuator dB	Presel					
Low Channel (1) - Z axis (Flat)												
2412	Peak	Horz	98.3	30.8	5.4	0.0	35.8	98.7				PASS
2412	Avg	Horz	86.9	30.8	5.4	0.0	35.8	87.3				PASS
2412	Peak	Vert	97.8	30.8	5.4	0.0	35.8	98.2				PASS
2412	Avg	Vert	85.9	30.8	5.4	0.0	35.8	86.3				PASS
2390	Peak	Horz	53.3	30.8	5.4	0.0	35.8	53.7	74.0	20.3		PASS
2390	Avg	Horz	37.6	30.8	5.4	0.0	35.8	38.0	54.0	16.0		PASS
2390	Peak	Vert	52.1	30.8	5.4	0.0	35.8	52.5	74.0	21.5		PASS
2390	Avg	Vert	36.9	30.8	5.4	0.0	35.8	37.3	54.0	16.7		PASS
Low Channel (1) - X axis (Horizontal)												
2412	Peak	Horz	95.5	30.8	5.4	0.0	35.8	95.9				PASS
2412	Avg	Horz	84.1	30.8	5.4	0.0	35.8	84.5				PASS
2412	Peak	Vert	96.7	30.8	5.4	0.0	35.8	97.1				PASS
2412	Avg	Vert	85.7	30.8	5.4	0.0	35.8	86.1				PASS
2390	Peak	Horz	49.5	30.8	5.4	0.0	35.8	49.9	74.0	24.1		PASS
2390	Avg	Horz	35.1	30.8	5.4	0.0	35.8	35.5	54.0	18.5		PASS
2390	Peak	Vert	51.2	30.8	5.4	0.0	35.8	51.6	74.0	22.4		PASS
2390	Avg	Vert	36.0	30.8	5.4	0.0	35.8	36.4	54.0	17.6		PASS
Low Channel (1) - Y axis (Vertical)												
2412	Peak	Horz	100.3	30.8	5.4	0.0	35.8	100.7				PASS
2412	Avg	Horz	89.4	30.8	5.4	0.0	35.8	89.8				PASS
2412	Peak	Vert	99.8	30.8	5.4	0.0	35.8	100.2				PASS
2412	Avg	Vert	88.4	30.8	5.4	0.0	35.8	88.8				PASS
2390	Peak	Horz	55.0	30.8	5.4	0.0	35.8	55.4	74.0	18.6		PASS
2390	Avg	Horz	38.7	30.8	5.4	0.0	35.8	39.1	54.0	14.9		PASS
2390	Peak	Vert	55.6	30.8	5.4	0.0	35.8	56.0	74.0	18.0		PASS
2390	Avg	Vert	39.7	30.8	5.4	0.0	35.8	40.1	54.0	13.9		PASS
4824	Peak	Horz	46.1	30.6	7.7	0.0	35.2	49.2	74.0	24.8		PASS
4824	Avg	Horz	31.4	30.6	7.7	0.0	35.2	34.5	54.0	19.5		PASS
4824	Peak	Vert	44.1	30.6	7.7	0.0	35.2	47.2	74.0	26.8		PASS
4824	Avg	Vert	30.7	30.6	7.7	0.0	35.2	33.8	54.0	20.2		PASS
7236	Peak	Horz	45.8	33.5	9.6	0.0	35.6	53.3	74.0	20.7		PASS
7236	Avg	Horz	32.0	33.5	9.6	0.0	35.6	39.5	54.0	14.5		PASS
7236	Peak	Vert	46.4	33.5	9.6	0.0	35.6	53.9	74.0	20.1		PASS
7236	Avg	Vert	32.7	33.5	9.6	0.0	35.6	40.2	54.0	13.8		PASS
9648	Peak	Horz	47.8	38.6	9.6	0.0	36.1	59.9	74.0	14.1		PASS
9648	Avg	Horz	33.7	38.6	9.6	0.0	36.1	45.8	54.0	8.2		PASS
9648	Peak	Vert	47.5	38.6	9.6	0.0	36.1	59.6	74.0	14.4		PASS
9648	Avg	Vert	33.8	38.6	9.6	0.0	36.1	45.9	54.0	8.1		PASS

Client	Ecobee Inc	
Product	WEM01	
Standard(s)	RSS 210 Issue 8:2010 / FCC Part 15 Subpart C 15:2014	

N-Protocol											
Test Frequency (MHz)	Detection mode	Antenna polarity (Horz/Vert)	Raw signal dB(µV)	Antenna factor dB	Cable			Received signal dB(µV/m)	Emission limit dB(µV/m)	Margin dB(µV)	Result
					loss dB + Preselector	Attenuator dB	Pre-Amp Gain dB				
Mid Channel (6) - Z axis (Flat)											
2437	Peak	Horz	100.6	30.8	5.4	0.0	35.8	101.0			PASS
2437	Avg	Horz	89.1	30.8	5.4	0.0	35.8	89.5			PASS
2437	Peak	Vert	94.4	30.8	5.4	0.0	35.8	94.8			PASS
2437	Avg	Vert	83.3	30.8	5.4	0.0	35.8	83.7			PASS
Mid Channel (6) - X axis (Horizontal)											
2437	Peak	Horz	95.6	30.8	5.4	0.0	35.8	96.0			PASS
2437	Avg	Horz	84.5	30.8	5.4	0.0	35.8	84.9			PASS
2437	Peak	Vert	94.8	30.8	5.4	0.0	35.8	95.2			PASS
2437	Avg	Vert	84.2	30.8	5.4	0.0	35.8	84.6			PASS
Mid Channel (6) - Y axis (Vertical)											
2437	Peak	Horz	97.0	30.8	5.4	0.0	35.8	97.4			PASS
2437	Avg	Horz	86.2	30.8	5.4	0.0	35.8	86.6			PASS
2437	Peak	Vert	99.2	30.8	5.4	0.0	35.8	99.6			PASS
2437	Avg	Vert	88.5	30.8	5.4	0.0	35.8	88.9			PASS
4874	Peak	Horz	42.8	30.6	7.7	0.0	35.2	45.9	74.0	28.1	PASS
4874	Avg	Horz	29.0	30.6	7.7	0.0	35.2	32.1	54.0	21.9	PASS
4874	Peak	Vert	46.1	30.6	7.7	0.0	35.2	49.2	74.0	24.8	PASS
4874	Avg	Vert	30.9	30.6	7.7	0.0	35.2	34.0	54.0	20.0	PASS
7311	Peak	Vert	46.5	33.5	9.6	0.0	35.6	54.0	74.0	20.0	PASS
7311	Avg	Vert	32.5	33.5	9.6	0.0	35.6	40.0	54.0	14.0	PASS
7311	Peak	Horz	45.9	33.5	9.6	0.0	35.6	53.4	74.0	20.6	PASS
7311	Avg	Horz	32.4	33.5	9.6	0.0	35.6	39.9	54.0	14.1	PASS
9748	Peak	Horz	48.0	38.6	9.6	0.0	36.1	60.1	74.0	13.9	PASS
9748	Avg	Horz	33.2	38.6	9.6	0.0	36.1	45.3	54.0	8.7	PASS
9748	Peak	Vert	46.8	38.6	9.6	0.0	36.1	58.9	74.0	15.1	PASS
9748	Avg	Vert	33.3	38.6	9.6	0.0	36.1	45.4	54.0	8.6	PASS

Client	Ecobee Inc	
Product	WEM01	
Standard(s)	RSS 210 Issue 8:2010 / FCC Part 15 Subpart C 15:2014	

N-Protocol												
Test Frequency (MHz)	Detection mode	Antenna polarity (Horz/Vert)	Raw signal dB(µV)	Antenna factor dB	Cable			Pre-Amp Gain dB	Received signal dB(µV/m)	Emission limit dB(µV/m)	Margin dB(µV)	Result
					loss dB + ecor	Attenuator dB	Attenuator dB					
High Channel (11) - Z axis (Flat)												
2462	Peak	Horz	96.9	30.8	5.4	0.0	35.8	97.3				PASS
2462	Avg	Horz	85.8	30.8	5.4	0.0	35.8	86.2				PASS
2462	Peak	Vert	93.6	30.8	5.4	0.0	35.8	94.0				PASS
2462	Avg	Vert	82.7	30.8	5.4	0.0	35.8	83.1				PASS
2483.5	Peak	Horz	54.2	30.8	5.4	0.0	35.8	54.6	74.0	19.4		PASS
2483.5	Avg	Horz	36.9	30.8	5.4	0.0	35.8	37.3	54.0	16.7		PASS
2483.5	Peak	Vert	48.7	30.8	5.4	0.0	35.8	49.1	74.0	24.9		PASS
2483.5	Avg	Vert	34.9	30.8	5.4	0.0	35.8	35.3	54.0	18.7		PASS
High Channel (11) - X axis (Horizontal)												
2462	Peak	Horz	91.7	30.8	5.4	0.0	35.8	92.1				PASS
2462	Avg	Horz	80.1	30.8	5.4	0.0	35.8	80.5				PASS
2462	Peak	Vert	94.9	30.8	5.4	0.0	35.8	95.3				PASS
2462	Avg	Vert	82.6	30.8	5.4	0.0	35.8	83.0				PASS
2483.5	Peak	Horz	47.2	30.8	5.4	0.0	35.8	47.6	74.0	26.4		PASS
2483.5	Avg	Horz	33.2	30.8	5.4	0.0	35.8	33.6	54.0	20.4		PASS
2483.5	Peak	Vert	54.7	30.8	5.4	0.0	35.8	55.1	74.0	18.9		PASS
2483.5	Avg	Vert	37.0	30.8	5.4	0.0	35.8	37.4	54.0	16.6		PASS
High Channel (11) - Y axis (Vertical)												
2462	Peak	Horz	99.2	30.8	5.4	0.0	35.8	99.6				PASS
2462	Avg	Horz	87.1	30.8	5.4	0.0	35.8	87.5				PASS
2462	Peak	Vert	98.5	30.8	5.4	0.0	35.8	98.9				PASS
2462	Avg	Vert	87.4	30.8	5.4	0.0	35.8	87.8				PASS
2483.5	Peak	Horz	54.3	30.8	5.4	0.0	35.8	54.7	74.0	19.3		PASS
2483.5	Avg	Horz	38.7	30.8	5.4	0.0	35.8	39.1	54.0	14.9		PASS
2483.5	Peak	Vert	55.0	30.8	5.4	0.0	35.8	55.4	74.0	18.6		PASS
2483.5	Avg	Vert	38.7	30.8	5.4	0.0	35.8	39.1	54.0	14.9		PASS
4924	Peak	Horz	43.7	33.5	7.7	0.0	35.2	49.7	74.0	24.3		PASS
4924	Avg	Horz	30.2	33.5	5.4	0.0	35.2	33.9	54.0	20.1		PASS
4924	Peak	Vert	44.5	33.5	5.4	0.0	35.2	48.2	74.0	25.8		PASS
4924	Avg	Vert	30.7	33.5	5.4	0.0	35.2	34.4	54.0	19.6		PASS
7386	Peak	Vert	46.3	38.6	9.6	0.0	35.6	58.9	74.0	15.1		PASS
7386	Avg	Vert	32.2	38.6	9.6	0.0	35.6	44.8	54.0	9.2		PASS
7386	Peak	Horz	46.4	38.6	9.6	0.0	35.6	59.0	74.0	15.0		PASS
7386	Avg	Horz	32.0	38.6	9.6	0.0	35.6	44.6	54.0	9.4		PASS
9848	Peak	Horz	46.8	40.1	9.6	0.0	36.1	60.4	74.0	13.6		PASS
9848	Avg	Horz	32.8	40.1	9.6	0.0	36.1	46.4	54.0	7.6		PASS
9848	Peak	Vert	46.7	40.1	9.6	0.0	36.1	60.3	74.0	13.7		PASS
9848	Avg	Vert	32.6	40.1	9.6	0.0	36.1	46.2	54.0	7.8		PASS

Client	Ecobee Inc	
Product	WEM01	
Standard(s)	RSS 210 Issue 8:2010 / FCC Part 15 Subpart C 15:2014	

Test Equipment List

Equipment	Model No.	Manufacturer	Last calibration date	Next calibration due date	Asset #
Spectrum Analyzer	8566B	HP	Oct 2, 2013	Oct 2, 2015	GEMC 190
Quasi Peak Adapter	85650A	HP	Oct 1, 2013	Oct 1, 2015	GEMC 191
Loop Antenna	EM 6871	Electro-Metrics	Feb 5, 2013	Feb 5, 2015	GEMC 70
Loop Antenna	EM 6872	Electro-Metrics	Feb 5, 2013	Feb 5, 2015	GEMC 71
BiLog Antenna	3142-C	ETS	Feb 4, 2013	Feb 4, 2015	GEMC 137
Attenuator 10 dB	8493B	Agilent	NCR	NCR	GEMC 133
4GHZ-12GHZ High Pass filter	11SH10-4000/T12000-0/0	K & L Microwave	NCR	NCR	GEMC 119
Chase Preamp 9kHz - 2 GHz	CPA9231A	Chase	Sept 9, 2014	Sept 9, 2016	GEMC 6403
Q-Par 1.5-18 GHz Horn	6878/24	Q-par	Sept 10, 2014	Sept 10, 2016	GEMC 6365
Horn Antenna 18 GHz - 26.5 GHz	SAS-572	A.H. Systems	Sept 9, 2014	Sept 9, 2016	GEMC 6371
18.0-26.5 GHz Harmonic Mixer	11970K	HP	Jan 28, 2014	Jan 28, 2016	GEMC 158
1-26G pre-amp	HP 8449B	HP	Sept 9, 2014	Sept 9, 2016	GEMC 6351
RF Cable 7m	LMR-400-7M-50OHM-MN-MN	LexTec	NCR	NCR	GEMC 28
RF Cable 1m	LMR-400-1M-50OHM-MN-MN	LexTec	NCR	NCR	GEMC 29
RF Cable 0.5M	LMR-400-0.5M-50OHM-MN-MN	LexTec	NCR	NCR	GEMC 31

This report module is based on GEMC template "FCC - 15.209 - Radiated Emissions_Rev1.doc"

Client	Ecobee Inc	
Product	WEM01	
Standard(s)	RSS 210 Issue 8:2010 / FCC Part 15 Subpart C 15:2014	

Power Spectral Density – 15.247 DM

Purpose

The purpose of this test is to ensure that the maximum power spectral density to the radiating element does not exceed the limits specified. This ensures that the modulation is significantly wide enough, or low enough in power that it will allow for co-operation of other wireless devices operating within this frequency allocation.

Limits and Methods

The limits are defined in 15.247(e).

For digitally modulated systems, the power spectral density conducted from the intentional radiator to the antenna shall not be greater than 8 dBm in any 3 kHz band during any time interval of continuous transmission.

The method is given in Section 10.2 of FCC KDB 558074: June 5, 2014.

Results

The EUT passed. Low, medium, and high band was tested. The worst case value for each protocol were measured with a 3 kHz resolution bandwidth.

B-Mode	-15.9 dBm/3 kHz
G-Mode	-13.5 dBm/3 kHz
N-Mode	-13.1 dBm/3 kHz

Graph(s)

The graphs shown below show the power spectral density of the device during the conducted measurement operation of the EUT. Low, middle, and high channel was investigated in each mode, with the worst case being presented.

Client	Ecobee Inc	
Product	WEM01	
Standard(s)	RSS 210 Issue 8:2010 / FCC Part 15 Subpart C 15:2014	

B Protocol, High Channel

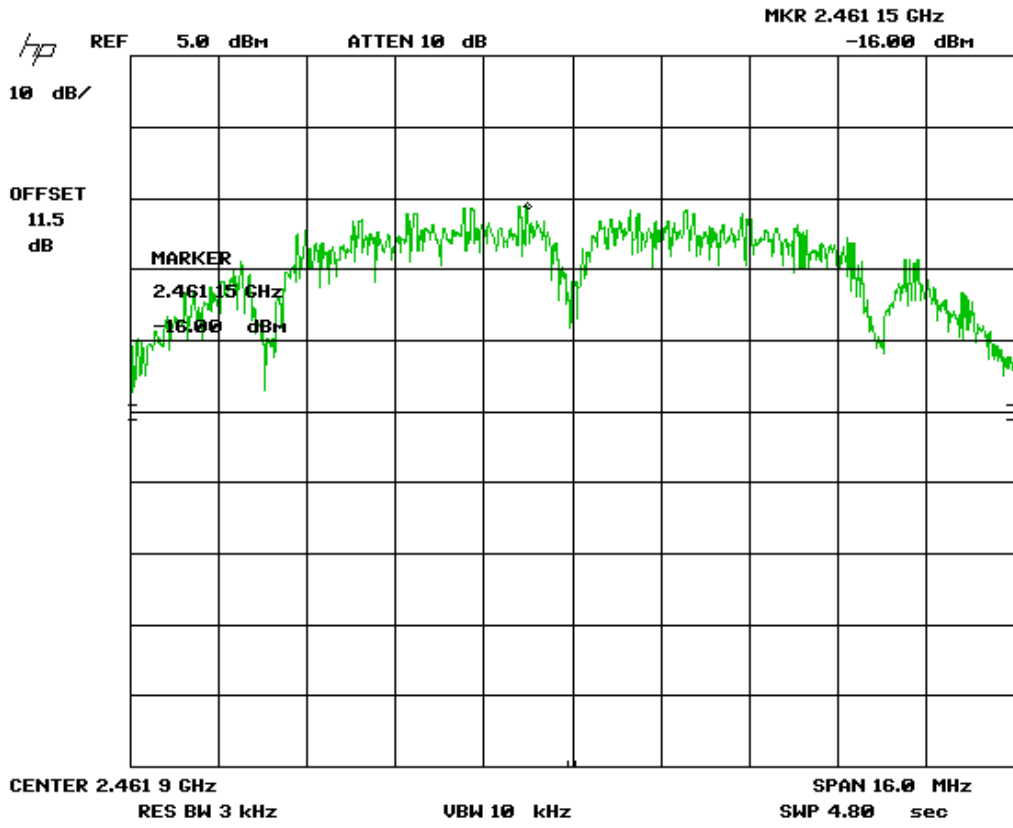

Client	Ecobee Inc	
Product	WEM01	
Standard(s)	RSS 210 Issue 8:2010 / FCC Part 15 Subpart C 15:2014	

B Protocol, Mid Channel

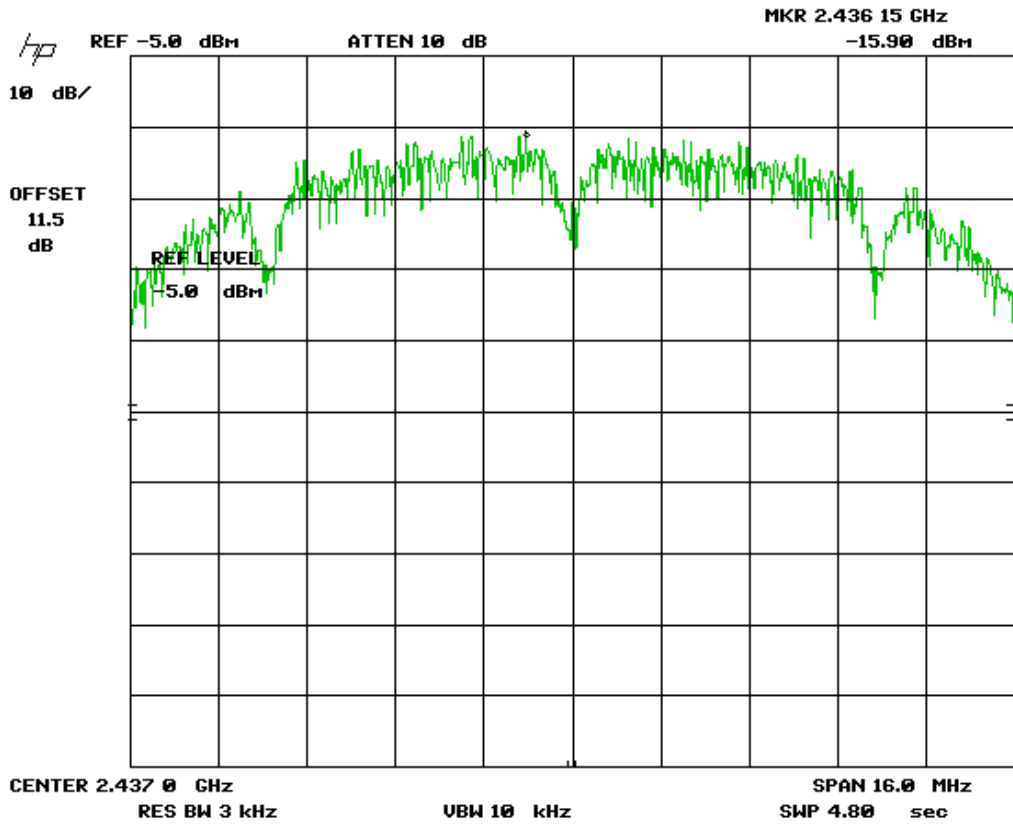

Client	Ecobee Inc	
Product	WEM01	
Standard(s)	RSS 210 Issue 8:2010 / FCC Part 15 Subpart C 15:2014	

B Protocol, Low Channel

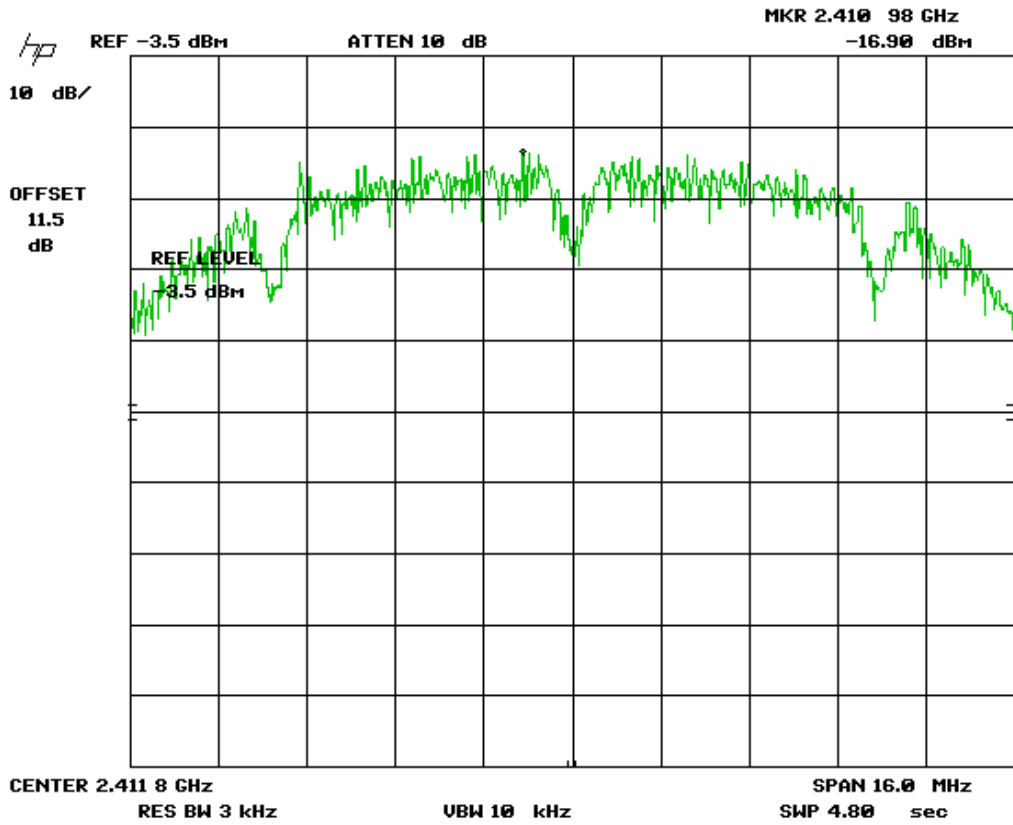

Client	Ecobee Inc	
Product	WEM01	
Standard(s)	RSS 210 Issue 8:2010 / FCC Part 15 Subpart C 15:2014	

G Protocol, High Channel

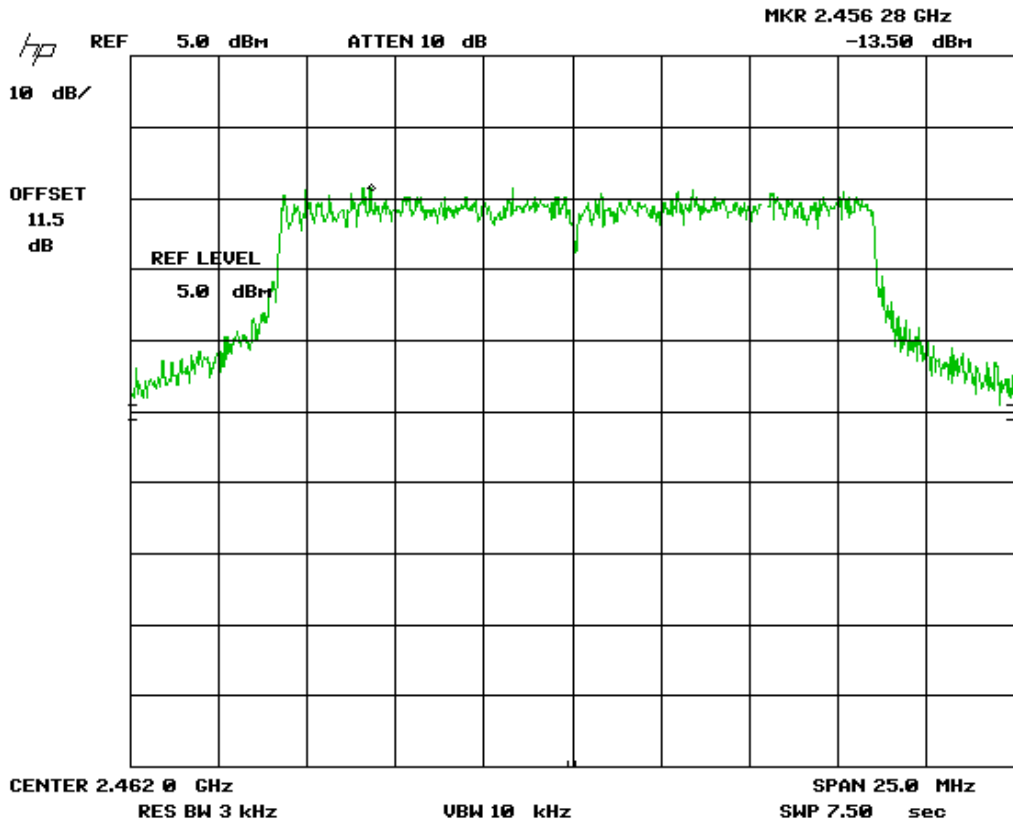

Client	Ecobee Inc	
Product	WEM01	
Standard(s)	RSS 210 Issue 8:2010 / FCC Part 15 Subpart C 15:2014	

G Protocol, Mid Channel

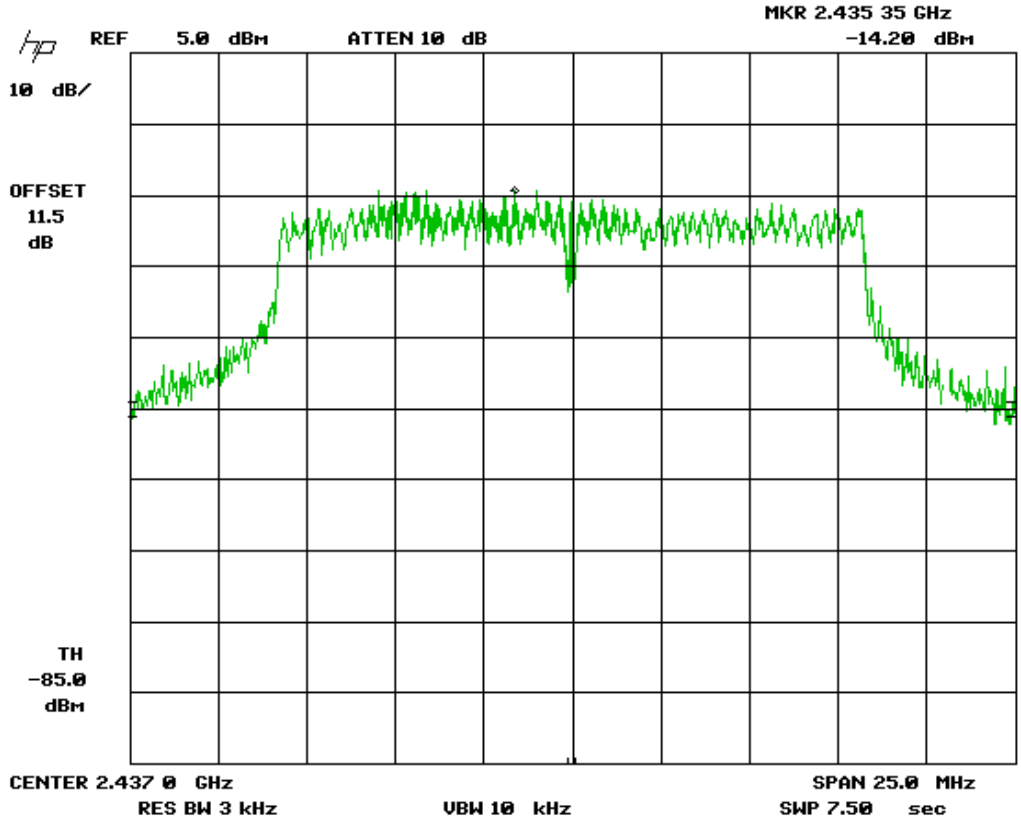

Client	Ecobee Inc	
Product	WEM01	
Standard(s)	RSS 210 Issue 8:2010 / FCC Part 15 Subpart C 15:2014	

G Protocol, Low Channel

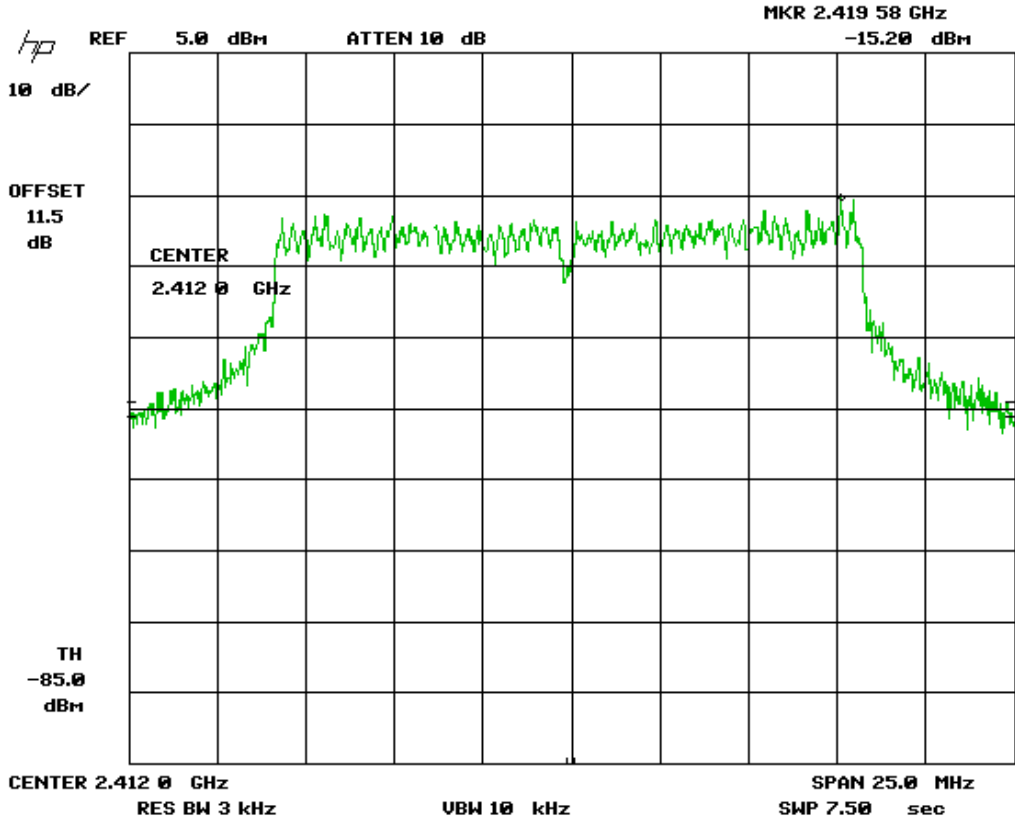

Client	Ecobee Inc	
Product	WEM01	
Standard(s)	RSS 210 Issue 8:2010 / FCC Part 15 Subpart C 15:2014	

N Protocol, High Channel

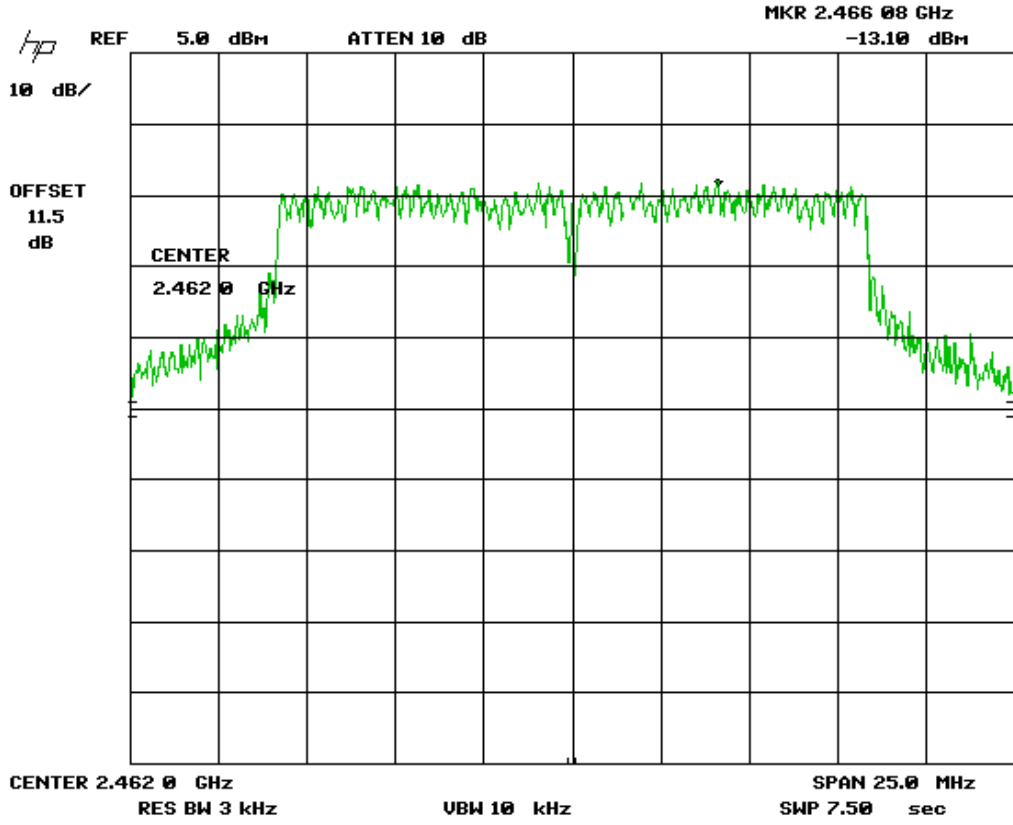

Client	Ecobee Inc	
Product	WEM01	
Standard(s)	RSS 210 Issue 8:2010 / FCC Part 15 Subpart C 15:2014	

N Protocol, Mid Channel

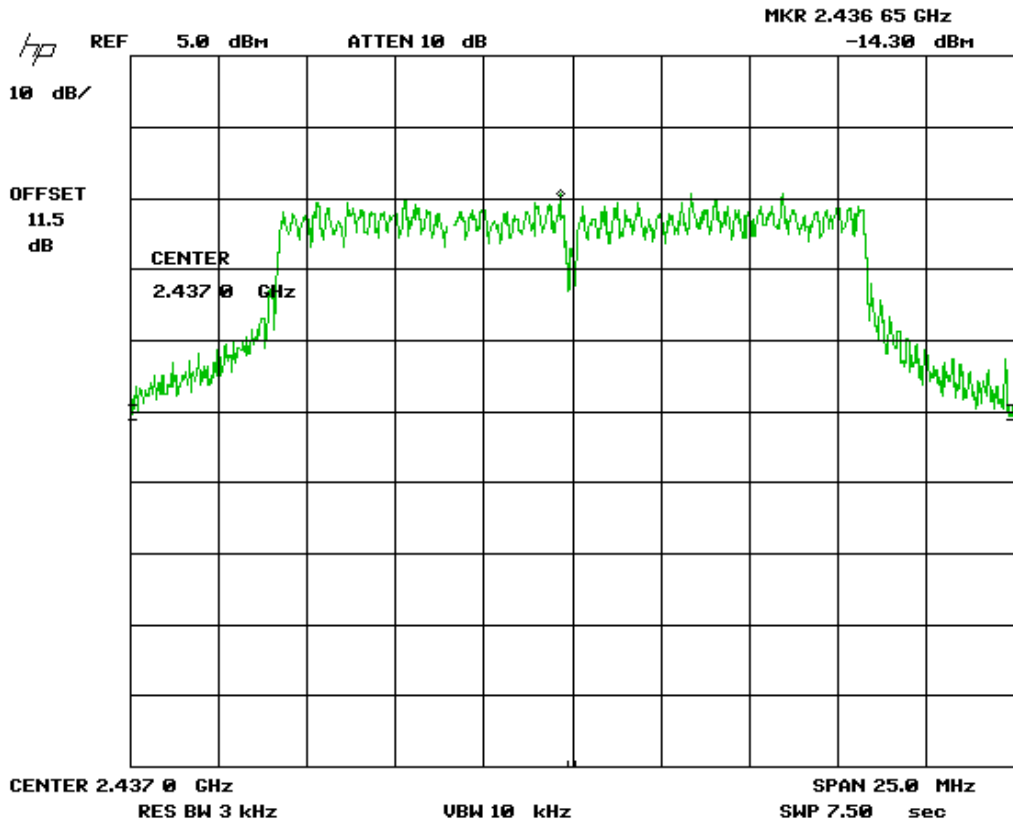

Client	Ecobee Inc	
Product	WEM01	
Standard(s)	RSS 210 Issue 8:2010 / FCC Part 15 Subpart C 15:2014	

N Protocol, Low Channel

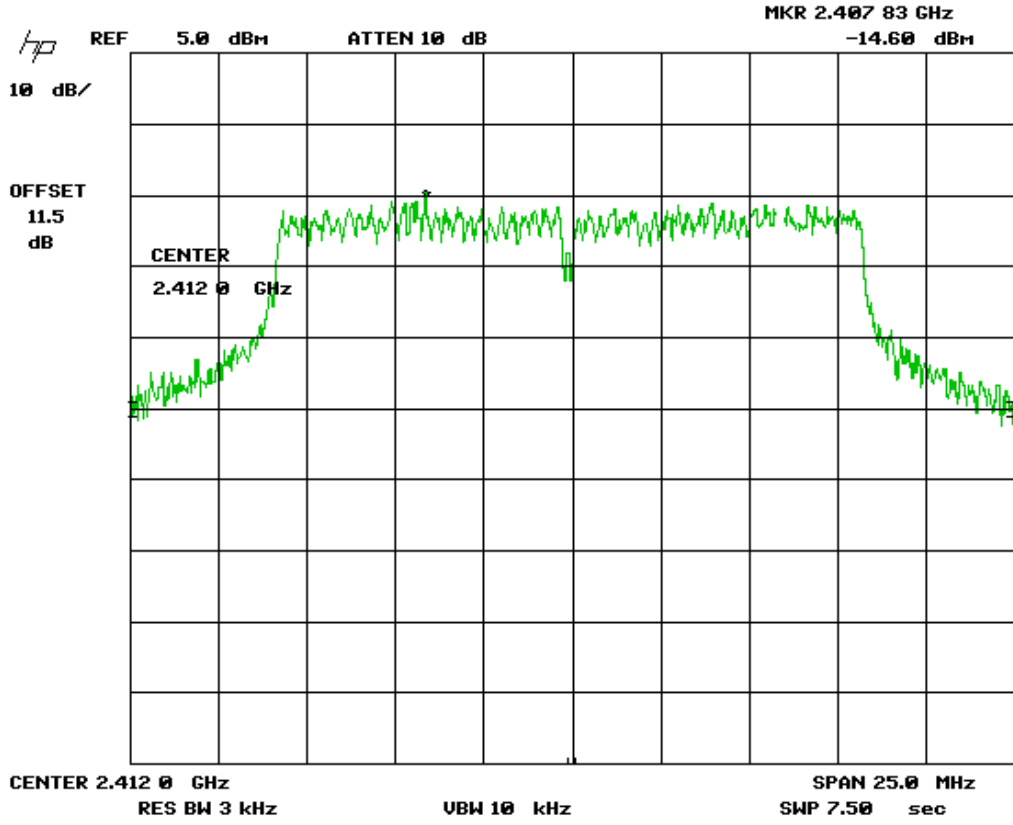

Note: See ‘Appendix B – EUT & Test Setup Photographs’ for photos showing the test set-up.

Test Equipment List

Equipment	Model No.	Manufacturer	Last calibration date	Next calibration due date	Asset #
Spectrum Analyzer	8566B	HP	Oct 2, 2013	Oct 2, 2015	GEMC 190
Quasi Peak Adapter	85650A	HP	Oct 1, 2013	Oct 1, 2015	GEMC 191
Attenuator 10 dB	8493B	Agilent	NCR	NCR	GEMC133
RF Cable 1m	LMR-400-1M-50OHM-MN-MN	LexTec	NCR	NCR	GEMC 29

This report module is based on GEMC template “FCC – Power Line Conducted Emissions Class B_Rev1”

Client	Ecobee Inc	
Product	WEM01	
Standard(s)	RSS 210 Issue 8:2010 / FCC Part 15 Subpart C 15:2014	

Maximum Permissible Exposure – 15.247

Purpose

The purpose of this test is to ensure that the RF energy intentionally transmitted, in terms of power density emitted from the EUT at a stated operating distance does not exceed the limits listed below as defined in the applicable test standard, as calculated based upon readings obtained during testing. This helps protect human exposure to excessive RF fields.

Limit(s) and Method

The limits, as defined in FCC 15.247(i) and FCC 1.1310 Table 1 (B) limits for general public exposure was applied. The limit for the frequency range of 1.5 GHz to 100 GHz was applied to the 15.247 device. This is a limit of 1.0 mW/cm². The distance used for calculations was 20 cm, as this is the minimum distance an operator will be from the EUT during normal operation, as stated by the manufacturer.

Results

The EUT passed the requirements. The worst case calculated power density was 0.017 mW/cm², this is significantly under the 1.0 mW/cm² requirement.

Calculations

Method 1 (conducted power)

Internal antenna

$$P_d = (P_t * G) / (4 * \pi * R^2)$$

Where $P_t = 17.23$ dBm or 52.84 mW as per Peak power conducted output

Where $G = 2.1$ dBi, or numerically 1.62

Where $R = 20$ cm

$$P_d = (52.84 \text{ mW} * 1.62) / (4 * \pi * 20\text{cm}^2)$$

$$P_d = 85.60 \text{ mW} / 5026 \text{ cm}^2$$

$$P_d = 0.017 \text{ mW/cm}^2$$

Client	Ecobee Inc	
Product	WEM01	
Standard(s)	RSS 210 Issue 8:2010 / FCC Part 15 Subpart C 15:2014	

Power Line Conducted Emissions

Purpose

The purpose of this test is to ensure that the RF energy unintentionally emitted from the EUT's power line does not exceed the limits listed below as defined in the applicable test standard, as measured from a LISN. This helps protect lower frequency radio services such as AM radio, shortwave radio, amateur radio operators, maritime radio, CB radio, and so on, from unwanted interference.

Limits & Method

The limits are as defined in 47 CFR FCC Part 15 Section 15.207

Method is as defined in ANSI C64.10:2009

Average Limits		QuasiPeak Limits	
150 kHz – 500 kHz	56 to 46 dBuV	150 kHz – 500 kHz	66 to 56 dBuV
500 kHz – 5 MHz	46 dBuV	500 kHz – 5 MHz	56 dBuV
5 MHz – 30 MHz	50 dBuV	500 kHz – 30 MHz	60 dBuV

The limit decreases linearly with the logarithm of the frequency in the range 0.15 MHz to 0.50 MHz.

Note: If the Peak or Quasi Peak detector measurements do not exceed the Average limits, then the EUT is deemed to have passed the requirements.

Both limits are applicable, and each is specified as being measured with a 9 kHz measurement bandwidth.

Client	Ecobee Inc	
Product	WEM01	
Standard(s)	RSS 210 Issue 8:2010 / FCC Part 15 Subpart C 15:2014	

Typical Setup Diagram

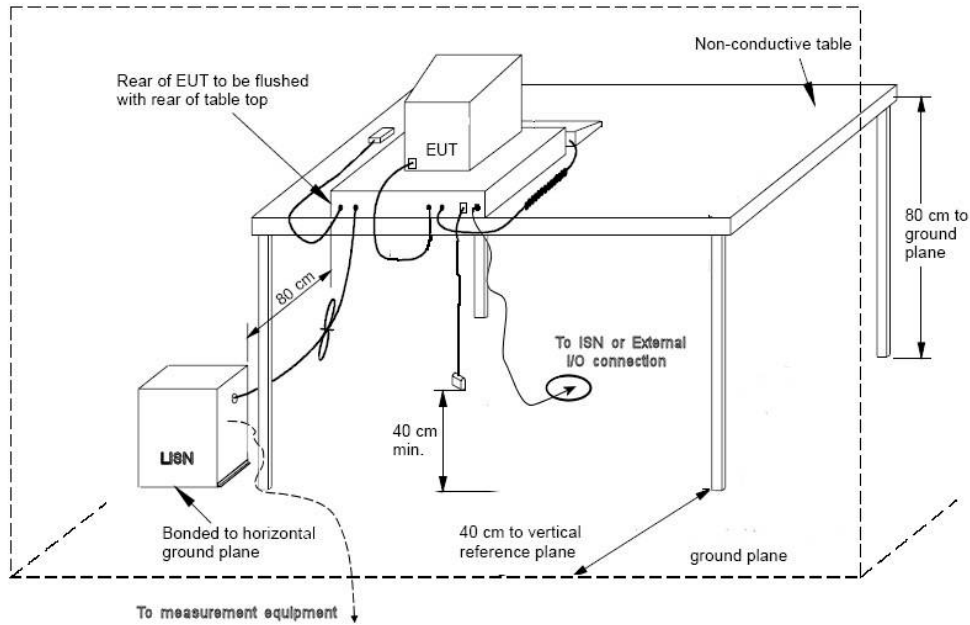

Measurement Uncertainty

The expanded measurement uncertainty is calculated in accordance with CISPR 16-4-2 and is ± 3.6 dB with a 'k=2' coverage factor and a 95% confidence level.

Preliminary Graphs

Note the graphs shown below are for graphical illustration only. For final measurements with the appropriate detector where applicable, please refer to the table. The graph shown below is a peak measurement graph, measured with a resolution bandwidth greater than or equal to the final required detector. These graphs are performed as a worst case measurement to enable the detection of frequencies of concern and for considerable time savings.

Power line conducted emissions were performed with the transmitter transmitting at 100% duty cycle.

Client	Ecobee Inc	
Product	WEM01	
Standard(s)	RSS 210 Issue 8:2010 / FCC Part 15 Subpart C 15:2014	

L1(Line) – 120Vac 60Hz

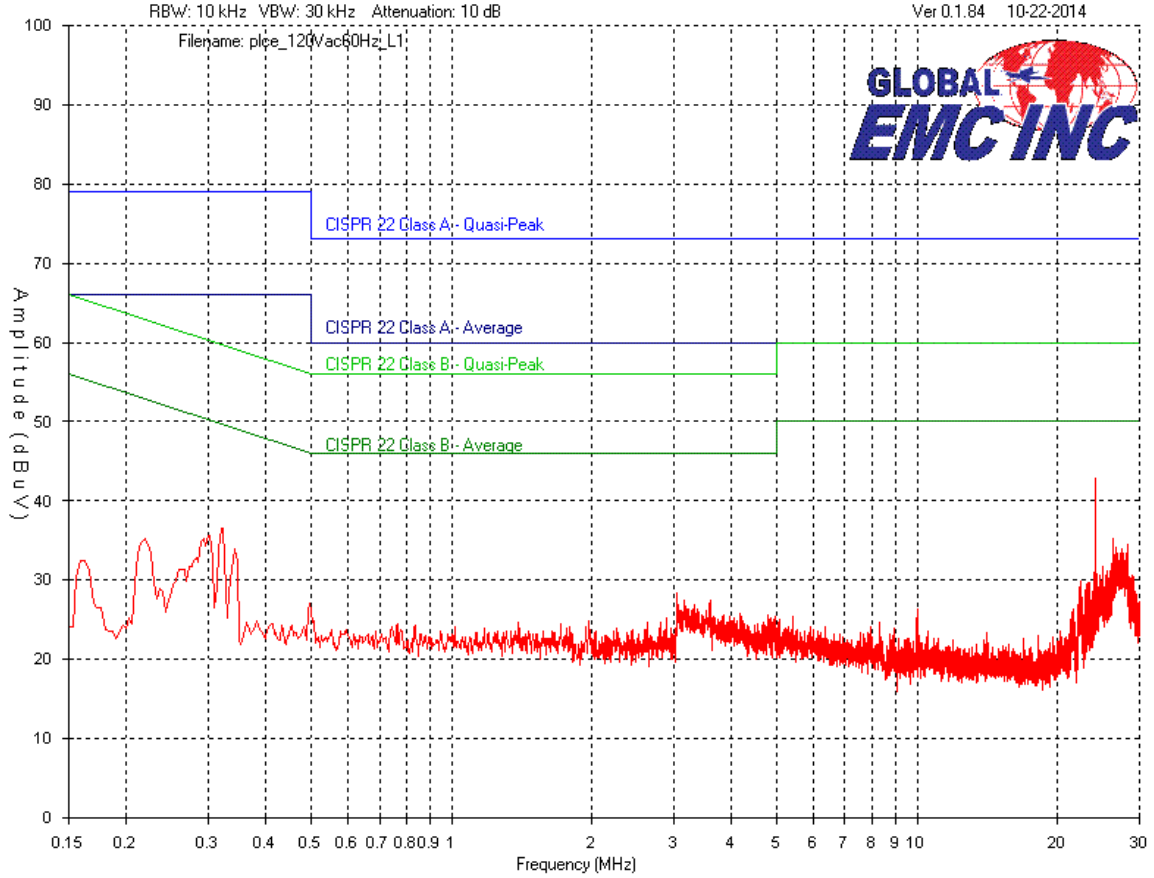

Client	Ecobee Inc	
Product	WEM01	
Standard(s)	RSS 210 Issue 8:2010 / FCC Part 15 Subpart C 15:2014	

L2 (Neutral) – 120Vac 60Hz

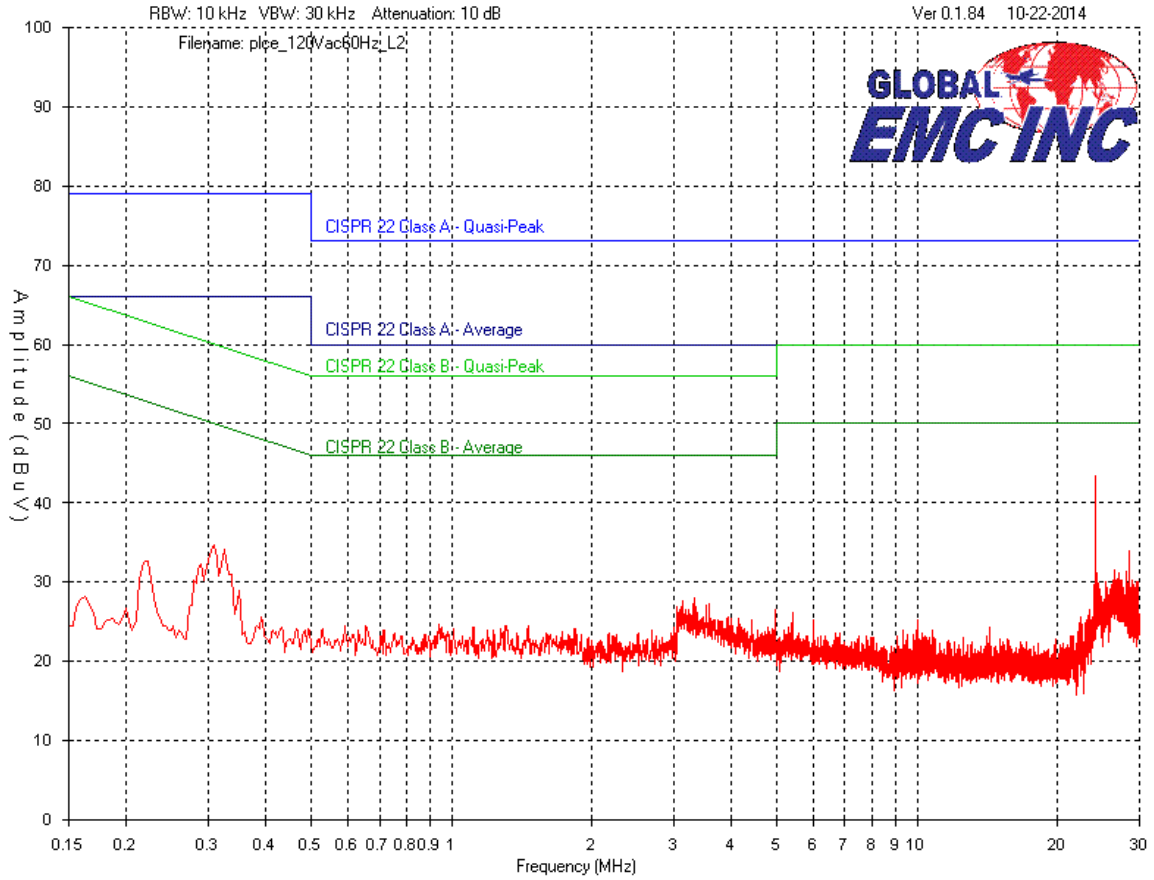

Client	Ecobee Inc	
Product	WEM01	
Standard(s)	RSS 210 Issue 8:2010 / FCC Part 15 Subpart C 15:2014	

Final Measurements

Product Category		Class B					
Product		WEM01					
Supply		120 VAC 60 Hz					
Line Emission Table							
Frequency (MHz)	Detector	Raw (dBuV)	Factors	Level (dBuV)	Limit (dB)	Margin (dB)	Pass/Fail
24.244	Peak	32.5	10.4	42.9	50	7.1	Pass
0.3228	Peak	26.4	10.2	36.6	49.6	13	Pass
0.2996	Peak	25.5	10.2	35.7	50.3	14.6	Pass
26.3144	Peak	24.8	10.4	35.2	50	14.8	Pass
0.3428	Peak	23.8	10.2	34	49.1	15.1	Pass
28.2951	Peak	24.2	10.5	34.7	50	15.3	Pass
Neutral Emission Table							
24.244	Peak	33.1	10.4	43.5	50	6.5	Pass
0.3095	Peak	24.5	10.2	34.7	50	15.3	Pass
28.6474	Peak	23.5	10.5	34	50	16	Pass
3.3171	Peak	17.8	10.2	28	46	18	Pass
26.6235	Peak	21.2	10.5	31.7	50	18.3	Pass
28.2087	Peak	20.9	10.5	31.4	50	18.6	Pass

Notes:

1. No peak emissions exceeded power line conducted emission average limits; therefore, the unit was deemed to meet power line conducted emission requirements base on peak emissions.
2. Power line conducted emissions was performed on the 120 Vac to 24 Vac step-down transformer.
3. See 'Appendix B – EUT & Test Setup Photographs' for photos showing the test set-up for the highest line conducted emission

Client	Ecobee Inc	
Product	WEM01	
Standard(s)	RSS 210 Issue 8:2010 / FCC Part 15 Subpart C 15:2014	

Test Equipment List

Equipment	Model No.	Manufacturer	Last calibration date	Next calibration due date	Asset #
Spectrum Analyzer	ESL 6	Rohde & Schwarz	Nov 15, 2013	Nov 15, 2015	GEMC 160
LISN	FCC-LISN-50/250-16-2-01	FCC	Feb 06, 2013	Feb 06, 2015	GEMC 65
RF Cable 7m	LMR-400-7M-50OHM-MN-MN	LexTec	NCR	NCR	GEMC 28

This report module is based on GEMC template "FCC -- Power Line Conducted Emissions Class B_Rev1"

Client	Ecobee Inc	
Product	WEM01	
Standard(s)	RSS 210 Issue 8:2010 / FCC Part 15 Subpart C 15:2014	

Appendix A – EUT Summary

Client	Ecobee Inc	
Product	WEM01	
Standard(s)	RSS 210 Issue 8:2010 / FCC Part 15 Subpart C 15:2014	

For further details for filing purposes, refer to filing package.

General EUT Description

Client	
Organization	Ecobee Inc 477 Richmond Street West, Ste 210 Toronto, ON, Canada M5R 3E7
Contact	Kashif Ahmed
Phone	416 987 1048
Email	kashif@ecobee.com
EUT Details	
EUT Name (for report title)	WEM01
EUT Model / SN (if known)	WEM01
FCC ID	WR9WEM01
Industry Canada #	7981A-WEM01
Equipment category	Wireless thermostat
EUT is powered using	AC
Input voltage range(s) (V)	24 Vac
Frequency range(s) (Hz)	60 Hz
Rated input current (A)	2 A
Number of power supplies in EUT	1
Transmits RF energy? (describe)	Yes
Basic EUT functionality description	Smart thermostat

Note the EUT is considered to have been received the date of the commencement of the first test, unless otherwise stated. For a close-up picture of the EUT, see ‘Appendix B – EUT & Test Setup Photographs’.

Client	Ecobee Inc	
Product	WEM01	
Standard(s)	RSS 210 Issue 8:2010 / FCC Part 15 Subpart C 15:2014	

EUT Configuration

Please see Appendix B for a picture of the unit running in normal conditions.

- Wireless were configured to transmit at 100% duty cycle

Operational Setup

These devices are required to be attached to the EUT for its normal operation.

- A debug board was connected to the EUT.

Client	Ecobee Inc	
Product	WEM01	
Standard(s)	RSS 210 Issue 8:2010 / FCC Part 15 Subpart C 15:2014	

Appendix B – EUT and Test Setup Photographs

Client	Ecobee Inc	
Product	WEM01	
Standard(s)	RSS 210 Issue 8:2010 / FCC Part 15 Subpart C 15:2014	



Figure 4: Radiated emission setup – photo 1

Client	Ecobee Inc	
Product	WEM01	
Standard(s)	RSS 210 Issue 8:2010 / FCC Part 15 Subpart C 15:2014	



Figure 5: Radiated emission setup – photo 2



Client	Ecobee Inc	
Product	WEM01	
Standard(s)	RSS 210 Issue 8:2010 / FCC Part 15 Subpart C 15:2014	



Figure 6: Radiated emission setup – photo 3

Client	Ecobee Inc	
Product	WEM01	
Standard(s)	RSS 210 Issue 8:2010 / FCC Part 15 Subpart C 15:2014	

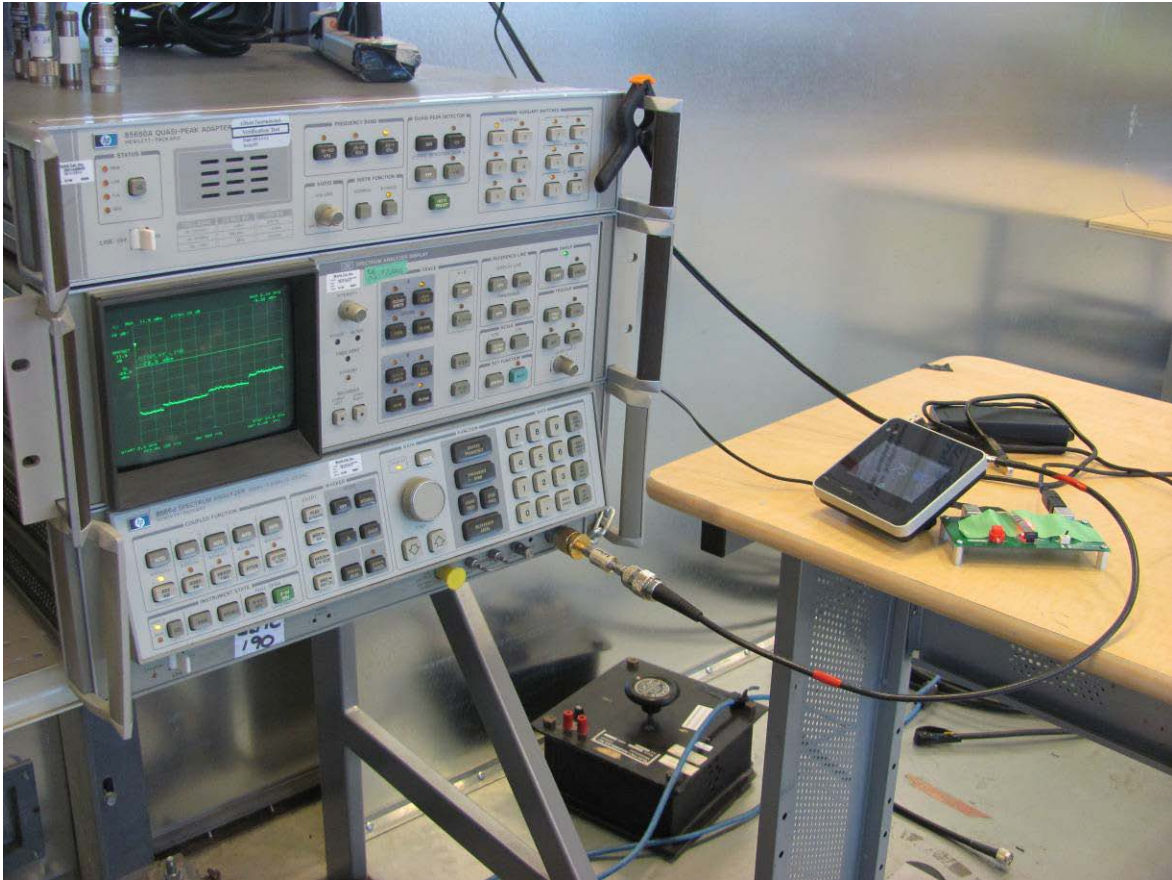



Figure 7: Antenna port conducted emission setup – photo

Client	Ecobee Inc	
Product	WEM01	
Standard(s)	RSS 210 Issue 8:2010 / FCC Part 15 Subpart C 15:2014	

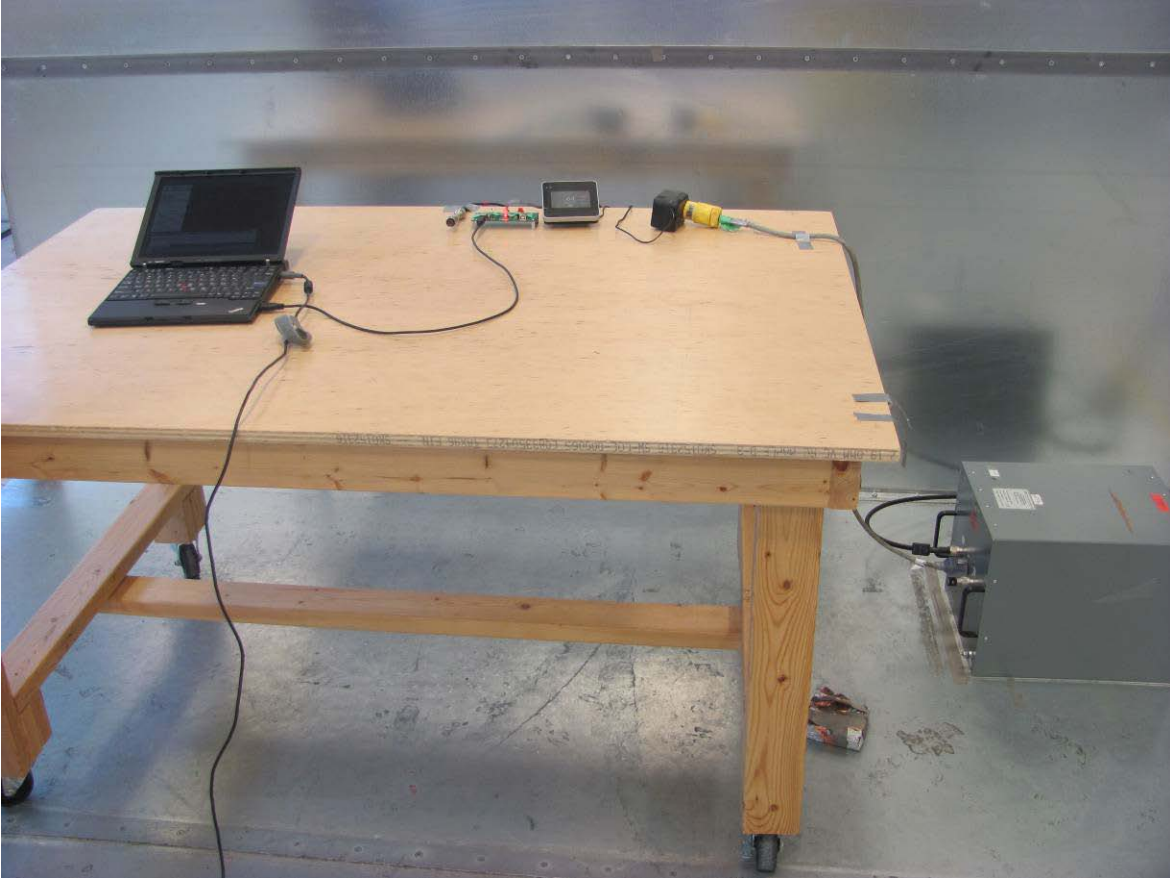



Figure 8: Power line conducted emission setup – photo 1

Client	Ecobee Inc	
Product	WEM01	
Standard(s)	RSS 210 Issue 8:2010 / FCC Part 15 Subpart C 15:2014	

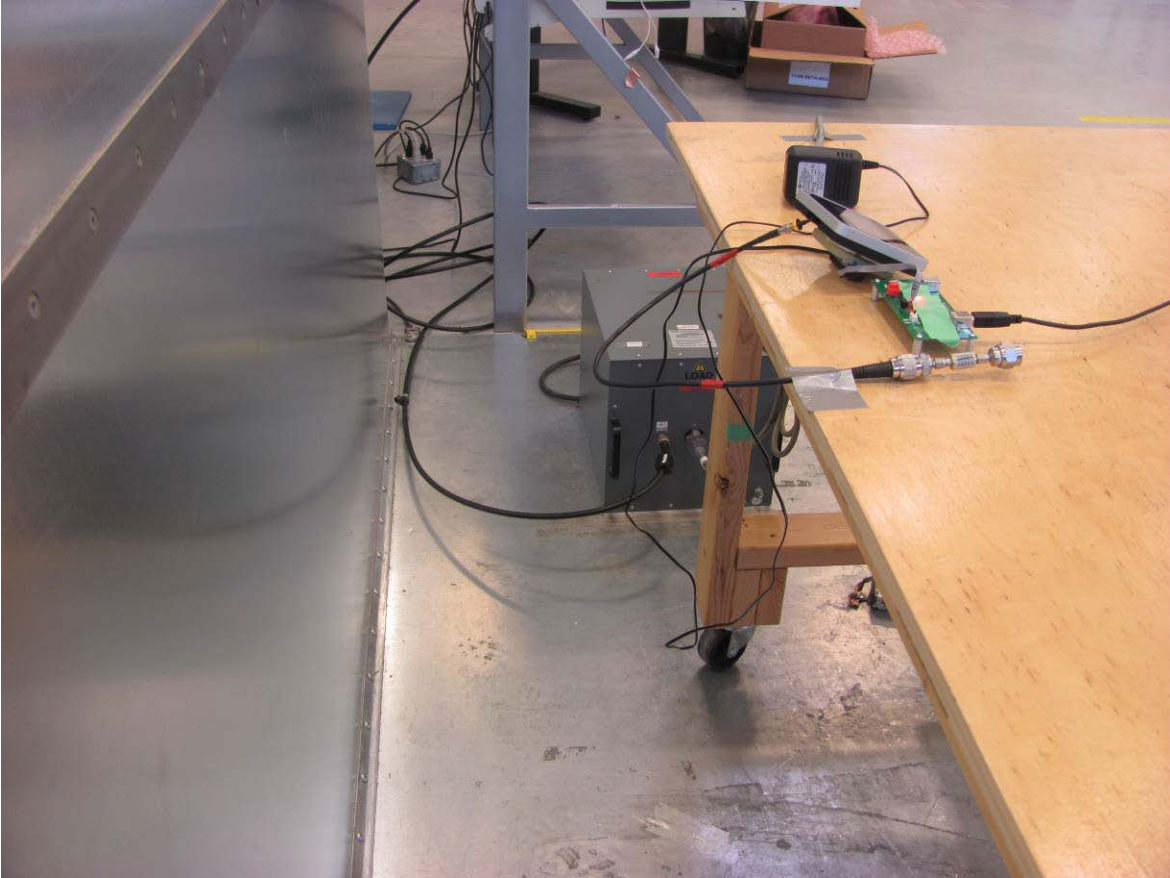

Figure 9: Power line conducted emission setup – photo 2