

TUV SUD Canada / Global EMC Inc. Labs

EMC & RF Test Report

As per

RSS 247 Issue 1:2015

&

FCC Part 15 Subpart C: 2016

Unlicensed Intentional Radiators

on the

Athena RS Gen 2

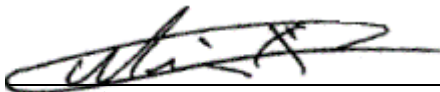

Min Xie
Project Engineer
11 Gordon Collins Dr,
Gormley, ON, L0H 1G0 Canada
Ph: (905) 883-8189

Testing produced for



See Appendix A for full customer & EUT details.





Client	Ecobee Inc	
Product	Athena RS Gen 2	
Standard(s)	RSS 247: 2015 / FCC Part 15 Subpart C 15:2016	

Table of Contents

Table of Contents	2
Report Scope	3
Summary	4
Test Results Summary	5
Justifications, Descriptions, or Deviations.....	6
Applicable Standards, Specifications and Methods.....	7
Sample calculation(s).....	8
Document Revision Status	8
Definitions and Acronyms	9
Testing Facility	10
Calibrations and Accreditations.....	10
Testing Environmental Conditions and Dates	11
Detailed Test Results Section	12
Channel Carrier Bandwidth	13
Carrier Frequency Separation	17
Number of Hopping Frequencies.....	21
Time of Occupancy.....	27
Maximum Peak Envelope Conducted Power - FHSS.....	32
Antenna Spurious Conducted Emissions (-20 dBc Requirement) – 15.247	35
Radiated Emissions – 15.247	40
RF Exposure.....	52
Appendix A – EUT Summary.....	54
Appendix B – EUT and Test Setup Photographs.....	57

Client	Ecobee Inc	
Product	Athena RS Gen 2	
Standard(s)	RSS 247: 2015 / FCC Part 15 Subpart C 15:2016	

Report Scope

This report addresses the EMC verification testing and test results of Ecobee Inc's Athena RS, herein referred to as EUT (Equipment Under Test) performed at TUV SUD Canada / Global EMC Labs.

The EUT was tested for compliance against the following standards:

RSS 247 Issue 1: 2015
FCC Part 15 Subpart C 15:2016

Test procedures, results, justifications, and engineering considerations, if any, follow later in this report.

The results contained in this report relate only to the item(s) tested.

This report does not imply product endorsement by A2LA or any other accreditation agency, any government, or TUV SUD Canada / Global EMC Inc.

Opinions/interpretations expressed in this report, if any, are outside the scope of TUV SUD Canada / Global EMC Inc accreditation. Any opinions expressed do not necessarily reflect the opinions of TUV SUD Canada / Global EMC Inc, unless otherwise stated.

Client	Ecobee Inc	
Product	Athena RS Gen 2	
Standard(s)	RSS 247: 2015 / FCC Part 15 Subpart C 15:2016	

Summary

The results contained in this report relate only to the item(s) tested.

EUT FCC Certification #, FCC ID:	WR9EBRSE4
EUT Industry Canada Certification #, IC:	7981A- EBRSE4
EUT Passed all tests performed.	Yes (see test results summary)
Tests conducted by	Min Xie

Client	Ecobee Inc	
Product	Athena RS Gen 2	
Standard(s)	RSS 247: 2015 / FCC Part 15 Subpart C 15:2016	

Test Results Summary

Standard/Method	Description	Class/Limit	Result
FCC 15.203	Antenna Requirement	Unique	Pass See Justification
FCC 15.205 RSS GEN Table 6	Restricted Bands for intentional operation	None within chart	Pass See description
FCC 15.207 RSS GEN Table 3	Power line conducted emissions	QuasiPeak Average	N/A See Justification
FCC 15.209 RSS GEN Table 4	Radiated emissions	QuasiPeak Average	Pass
FCC 15.247(a)(1) RSS 247 5.1 (2)	Channel Separation	> 25 kHz or 20 dB BW	Pass
FCC 15.247(a)(1)(i) RSS 247 5.1 (3)	Number of channels	> 50	Pass
FCC 15.247(a)(1)(i) RSS 247 5.1 (3)	Time of occupancy	< 0.4 sec in 20 sec period	Pass
FCC 15.247(b) RSS 247 5.4(1)	Max output power	< 1 Watt	Pass
FCC 15.247(b)(4) RSS 247 5.4 (3)	Antenna Gain	< 6 dBi	Pass See Justification
FCC 15.247(d) RSS 247 5.5	Antenna conducted spurious	> 20 dBc	Pass
FCC 15.247(h) RSS GEN 247 5.1	FHSS Intelligence	No coordination	Pass See Justification
FCC 15.247(i) RSS-102	Maximum Permissible Exposure	> 20 cm separation.	Pass See justification and calculations
Overall Result			PASS

All tests were performed by Min Xie.

If the product as tested or otherwise complies with the specification, the EUT is deemed to comply with the requirement and is deemed a 'PASS' grade. If not 'FAIL' grade will be issued. Note that 'PASS' / 'FAIL' grade is independent of any measurement uncertainties. A 'PASS' / 'FAIL' grade within measurement uncertainty is marked with a '*'.

Client	Ecobee Inc	
Product	Athena RS Gen 2	
Standard(s)	RSS 247: 2015 / FCC Part 15 Subpart C 15:2016	

Justifications, Descriptions, or Deviations

The following justifications for tests not performed or deviations from the above listed specifications apply:

For the Antenna requirement specified in FCC 15.203 (RSS 210 section 5.5), the unit uses a 900 MHz SMD antenna with 2 dBi peak gain.

For the Restricted Bands of operation, the EUT is designed to only operate between 902 – 928 MHz.

For 15.207 power line conducted emissions, the EUT is a battery powered device; thus, this requirement is not applicable.

The unit was tested with a new batteries during all tests.

For maximum permissible exposure is designed to operate greater than 20 cm from any personnel during normal operation. No testing is required, however worst case calculated exposure compliance follows later in this report.

For the scope of this test report the EUT was mounted in three orthogonal axes to maximize emissions. Worst case results are presented.

The EUT have two data rates. The higher rate uses a larger frequency deviation which results in a larger bandwidth. 20 dB bandwidth was tested for both data rates. The larger 20 dB bandwidth were applied to rules section that depends on it.

The higher data rate have one less channel compared to the lower data rate version. Band edges data were shown for both data rates.

The EUT does not coordination transmission with any other FHSs to avoid simultaneous occupation of hopping frequencies.

Client	Ecobee Inc	
Product	Athena RS Gen 2	
Standard(s)	RSS 247: 2015 / FCC Part 15 Subpart C 15:2016	

Applicable Standards, Specifications and Methods

ANSI C63.4:2014	Methods of Measurement of Radio-Noise Emissions from Low-Voltage Electrical and Electronic Equipment in the Range of 9 kHz to 40 GHz
ANSI C63.10:2013	American national standard for testing unlicensed wireless devices
CFR 47 FCC 15	Code of Federal Regulations – Radio Frequency Devices
CISPR 22:2008	Information technology equipment – Radio disturbance characteristics – Limits and methods of measurement
FCC KDB 558074	FCC KDB 558074 Digital Transmission Systems, measurements and procedures
ICES-003:2012	Digital Apparatus - Spectrum Management and Telecommunications Policy Interference-Causing Equipment Standard
ISO 17025:2005	General Requirements for the competence of testing and calibration laboratories
RSS-GEN Issue 4	General Requirements and Information for the Certification of Radio Apparatus
RSS-247 Issue 1	Digital Transmission Systems (DTSs), Frequency Hopping Systems (FHSs) and License-Exempt Local Area Network (LE-LAN) Devices
RSS 102 Issue 5	Radio Frequency (RF) Exposure Compliance of Radiocommunication Apparatus (All Frequency Bands)

Client	Ecobee Inc	
Product	Athena RS Gen 2	
Standard(s)	RSS 247: 2015 / FCC Part 15 Subpart C 15:2016	

Sample calculation(s)

Margin = limit – (received signal + antenna factor + cable loss – pre-amp gain)

Margin = 50.5dBuV/m – (50dBuV + 10dB + 2.5dB – 20dB)

Margin = 8.5 dB

Document Revision Status

Revision 1 - April 20, 2016
Initial release

Client	Ecobee Inc	
Product	Athena RS Gen 2	
Standard(s)	RSS 247: 2015 / FCC Part 15 Subpart C 15:2016	

Definitions and Acronyms

The following definitions and acronyms are applicable in this report.
See also ANSI C63.14.

AE – Auxillary Equipment.

BW – Bandwidth. Unless otherwise stated, this is refers to the 6 dB bandwidth.

EMC – Electro-Magnetic Compatibility

EMI – Electro-Magnetic Immunity

EUT – Equipment Under Test

ITE – Information Technology Equipment with a primary function(s) of entry, storage, display, retrieval, transmission, processing, switching, or control, of data.

LISN – Line impedance stabilization network

NCR – No Calibration Required

RF – Radio Frequency

Client	Ecobee Inc	
Product	Athena RS Gen 2	
Standard(s)	RSS 247: 2015 / FCC Part 15 Subpart C 15:2016	

Testing Facility

Testing for EMC on the EUT was carried out at TUV SUD Canada / Global EMC labs in Toronto, Ontario, Canada. The testing lab consists of a 3m semi-anechoic chamber calibrated to be able to allow measurements on an EUT with a maximum width or length of up to 2m and height up to 3m. The chamber is equipped with a turn table that is capable of testing devices up to 3300lb in weight. This facility is capable of testing products that are rated for 120 Vac and 240Vac single phase, or 208 Vac 3 phase input. DC capability is also available. The chamber is equipped with an antenna mast that controls polarization and height from the control room adjoining the shielded chamber. Radiated emissions measurements are performed using a Bilog, and Horn antenna where applicable. Conducted emissions, unless otherwise stated, are performed using a LISN.

Calibrations and Accreditations

The 3m semi-anechoic chamber is registered with Federal Communications Commission (FCC, 377448), Industry Canada (IC, 6844A-3) and VCCI (R-4023, G-506, T-1246, and C-4498). This semi-anechoic chamber complies with the requirements of EN55016-2-3:2006, section 7.5 and the site attenuation requirements of EN55016-1-4. This chamber was additionally calibrated for Normalized Site Attenuation (NSA) using test procedures outlined in ANSI C63.4 “Methods of Measurement of Radio-Noise Emissions from Low-Voltage Electrical and Electronic Equipment in the Range of 9 kHz to 40 GHz”. The chamber is lined with ferrite tiles and absorption cones to minimize any undesired reflections. The NSA data is kept on file at TUV SUD Canada / Global EMC. For radiated susceptibility testing, a 16 point field calibration has been performed on the chamber. The field uniformity data is kept on file at TUV SUD Canada / Global EMC. TUV SUD Canada / Global EMC Inc is accredited to ISO 17025 by A2LA with Testing Certificate #2555.01. The laboratories current scope of accreditation listing can be found as listed on the A2LA website. All measuring equipment is calibrated on an annual or bi-annual basis as listed for each respective test.

Client	Ecobee Inc	
Product	Athena RS Gen 2	
Standard(s)	RSS 247: 2015 / FCC Part 15 Subpart C 15:2016	

Testing Environmental Conditions and Dates

Following were the environmental conditions in the facility during time of testing –

Date	Test	Init.	Temperature (°C)	Humidity (%)	Pressure (kPa)
2016/3/24	RE	MX	20-24°C	35 – 41%	98 -103kPa
2016/4/1	Antenna Conducted	MX	20-24°C	35 – 41%	98 -103kPa

Client	Ecobee Inc	
Product	Athena RS Gen 2	
Standard(s)	RSS 247: 2015 / FCC Part 15 Subpart C 15:2016	

Detailed Test Results Section

Client	Ecobee Inc	
Product	Athena RS Gen 2	
Standard(s)	RSS 247: 2015 / FCC Part 15 Subpart C 15:2016	

Channel Carrier Bandwidth

Purpose

The purpose of this test is to allow for results that is used to help establish other limits. Although there is not specific limit for this requirement, the derived limits dependant on this information helps allow for other spread spectrum devices to co-exist in the same frequency spectrum.. This also helps prevent corruption of data by ensuring adequate channel separation to distinguish the reception of the intended information.

Limits and Methods

The limits are as defined in 47 CFR FCC Part 15 Section 15.247(a)(1). The test method is a defined in ANSI C63.10.

The maximum allowed 20 dB bandwidth for frequency hopping system operating in the 902 to 928 MHz band is 500 kHz.

Results

The EUT passed. The largest 20 dB BW measured was 132.2 kHz.

38.4 kbps		
Channel	Frequency (MHz)	20 dB Bandwidth (kHz)
Low Channel	902.5	79.8
Mid Channel	915.1	78.5
High Channel	927.7	78.5

500 kbps		
Channel	Frequency (MHz)	20 dB Bandwidth (kHz)
Low Channel	902.5	125.0
Mid Channel	915.1	132.2
High Channel	927.4	127.4

Client	Ecobee Inc	
Product	Athena RS Gen 2	
Standard(s)	RSS 247: 2015 / FCC Part 15 Subpart C 15:2016	

Graph(s)

The graphs shown below shows the channel spacing during the operation of the device. This is measured by a max hold on the spectrum analyzer and the highest resolution bandwidth that is sufficiently low to exhibit the 20 dB bandwidth of a channel during operation of the EUT. This measurement is a peak measurement. Max hold is performed for a duration of not less then 1 minute.

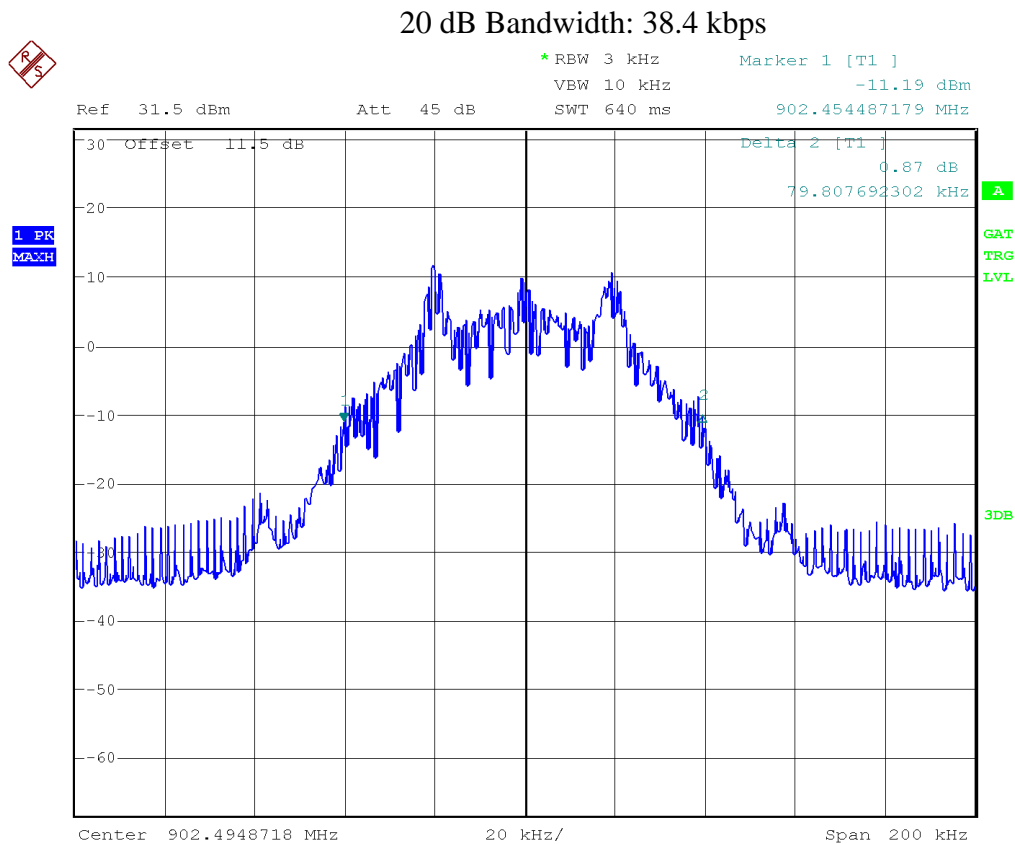

Date: 31.MAR.2016 18:09:41

Client	Ecobee Inc	
Product	Athena RS Gen 2	
Standard(s)	RSS 247: 2015 / FCC Part 15 Subpart C 15:2016	

20 dB Bandwidth: 500 kbps

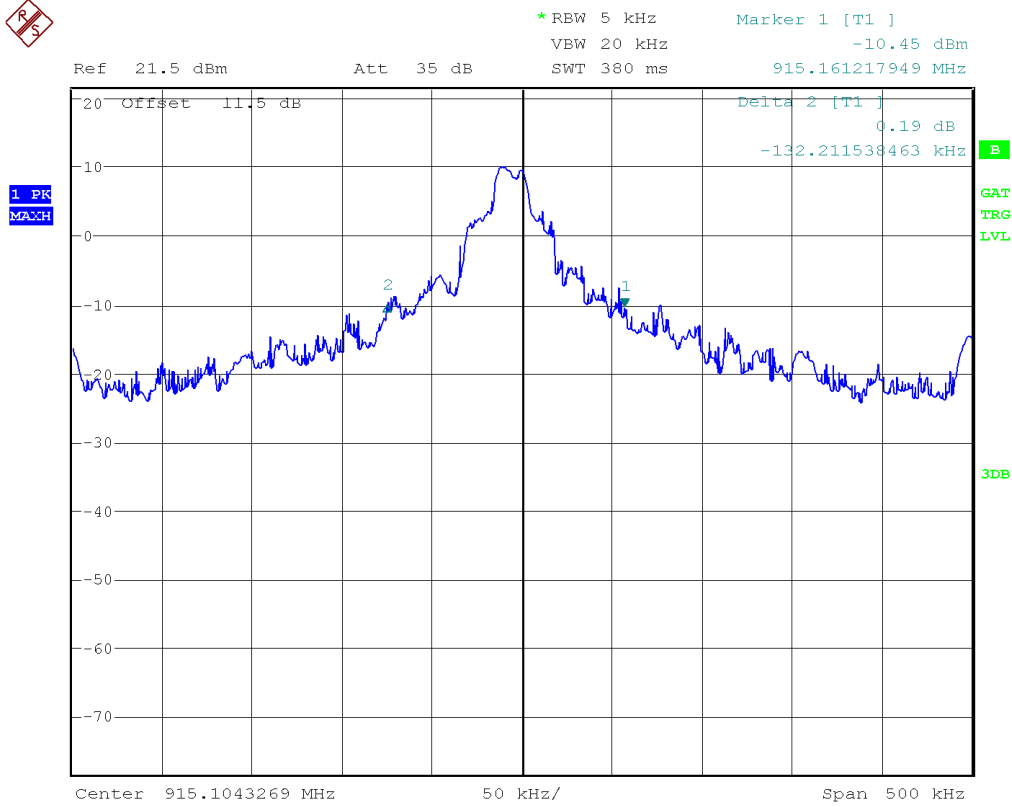

Date: 5.APR.2016 13:53:41

Note: See 'Appendix B – EUT & Test Setup Photographs' for photos showing the test set-up.

Client	Ecobee Inc	
Product	Athena RS Gen 2	
Standard(s)	RSS 247: 2015 / FCC Part 15 Subpart C 15:2016	

Test Equipment List

Equipment	Model No.	Manufacturer	Last calibration date	Next calibration due date	Asset #
Spectrum Analyzer	FSU	Rohde & Schwarz	Jan 19, 2015	Jan 19, 2017	GEMC 198
Attenuator 10 dB	8493B	Agilent	Feb 11, 2016	Feb 11, 2017	GEMC133

This report module is based on GEMC template "FCC – Power Line Conducted Emissions Class B_Rev1"

Client	Ecobee Inc	
Product	Athena RS Gen 2	
Standard(s)	RSS 247: 2015 / FCC Part 15 Subpart C 15:2016	

Carrier Frequency Separation

Purpose

The purpose of this test is to ensure that the RF energy of frequency hopping systems is sufficiently spread over a spectrum and that the radio energy is not overly dense. This limit helps allow for other spread spectrum devices to co-exist in the same frequency spectrum. This also helps prevent corruption of data by ensuring adequate channel separation to distinguish the reception of the intended information.

Limits and method

The limits are as defined in 47 CFR FCC Part 15 Section 15.247(a)(1). The test method is a defined in ANSI C63.10.

	902 to 928 MHz	2400 to 2483.5 MHz	5275 to 5850 MHz
No conditions	25 kHz or 20 dB BW ¹	25 kHz or 20 dB BW ¹	25 kHz or 20 dB BW ¹
< 125 mW	--	25 kHz or 2/3 of 20 dB BW ¹	--

Note 1: The greater of the 20 dB BW or 25 kHz. The maximum 20 dB BW of the system was measured to be 132.2 kHz, so a limit of 132.2 kHz applies.

Results

The EUT passed the requirements of channel carrier spacing exceeding the measured 20 dB BW of the EUT. The 20 dB BW previously measured was 132.2 kHz, and the device had a minimum channel spacing of 346.2 kHz.

Client	Ecobee Inc	
Product	Athena RS Gen 2	
Standard(s)	RSS 247: 2015 / FCC Part 15 Subpart C 15:2016	

Graph(s)

The graphs shown below shows the channel spacing during the operation of the device. This is measured by a max hold on the spectrum analyzer and the highest resolution bandwidth that is sufficiently low to exhibit the channel spacing of the signal being measured. This measurement is a peak measurement. Max hold is performed for a duration of not less than 1 minute, as the device is stepping through its hopping table.

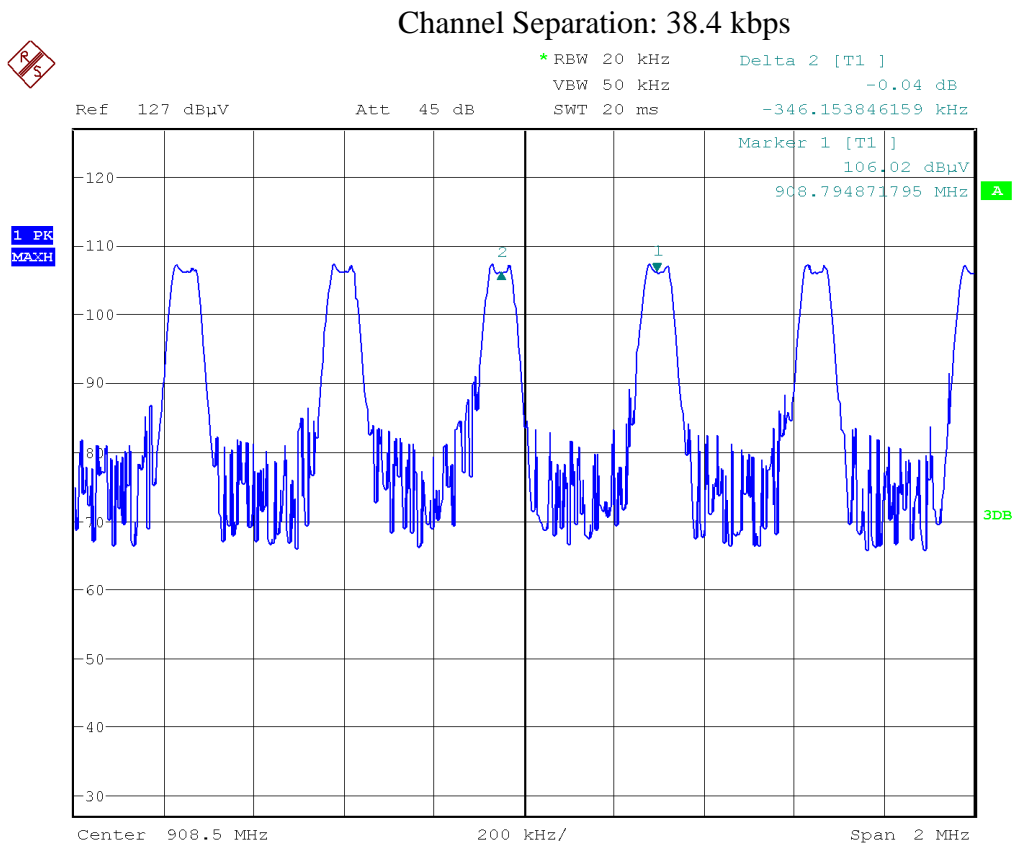

Date: 31.MAR.2016 16:27:14

Client	Ecobee Inc	
Product	Athena RS Gen 2	
Standard(s)	RSS 247: 2015 / FCC Part 15 Subpart C 15:2016	

Channel Separation: 500 kbps

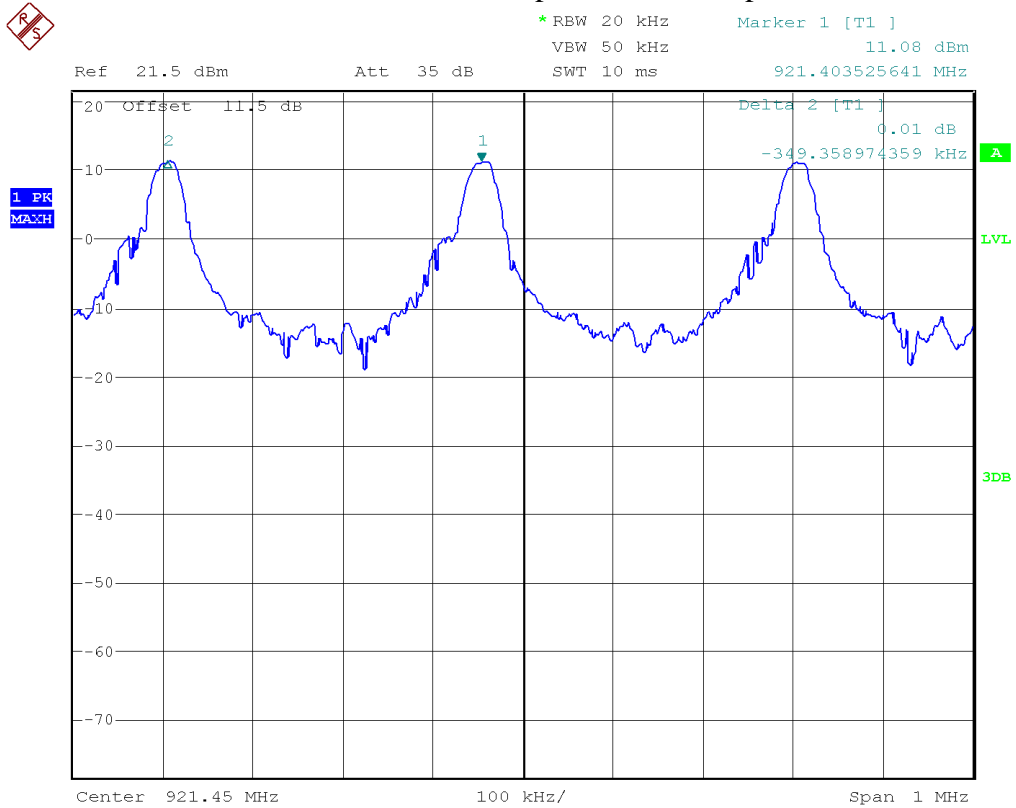

Date: 1.APR.2016 19:24:17

Note: See 'Appendix B – EUT & Test Setup Photographs' for photos showing the test set-up.

Client	Ecobee Inc	
Product	Athena RS Gen 2	
Standard(s)	RSS 247: 2015 / FCC Part 15 Subpart C 15:2016	

Test Equipment List

Equipment	Model No.	Manufacturer	Last calibration date	Next calibration due date	Asset #
Spectrum Analyzer	FSU	Rohde & Schwarz	Jan 19, 2015	Jan 19, 2017	GEMC 198
Attenuator 10 dB	8493B	Agilent	Feb 11, 2016	Feb 11, 2017	GEMC133

This report module is based on GEMC template "FCC – Power Line Conducted Emissions Class B_Rev1"

Client	Ecobee Inc	
Product	Athena RS Gen 2	
Standard(s)	RSS 247: 2015 / FCC Part 15 Subpart C 15:2016	

Number of Hopping Frequencies

Purpose

The purpose of this test is to ensure that the RF energy of frequency hopping systems is sufficiently spread over a spectrum and that the radio energy is not overly dense. This limit helps allow for other spread spectrum devices to co-exist in the same frequency spectrum. This also helps prevent corruption of data by ensuring adequate channel separation to distinguish the reception of the intended information.

Limits and method

The limits are as defined in 47 CFR FCC Part 15 Section 15.247(a)(1). The test method is a defined in ANSI C63.10.

	902 to 928 MHz	2400 to 2483.5 MHz	5275 to 5850 MHz
No conditions	≥ 50 channels	≥ 15 channels	≥ 75 channels
20 dB BW exceeds 250 kHz	≥ 25 channels	≥ 15 channels	≥ 75 channels

Results

The EUT passed the requirements of the number of channels. The number of channels the device occupies is 72 channels for 38.4 kbps and 71 channels for 500 kbps data rate in the allocation band of 902 to 928 MHz.

Client	Ecobee Inc	
Product	Athena RS Gen 2	
Standard(s)	RSS 247: 2015 / FCC Part 15 Subpart C 15:2016	

Graph(s)

The graphs shown below shows the number of occupied channels during the operation of the device. This is measured by a max hold on the spectrum analyzer and the highest resolution bandwidth that is sufficiently low to exhibit the channel spacing of the signal being measured. This measurement is a peak measurement. Max hold is performed for a duration of not less than 10 minutes, or as sufficient to capture the channels occupied.

Graph 1 of 2 (36 channels): 38.4 kbps data rate

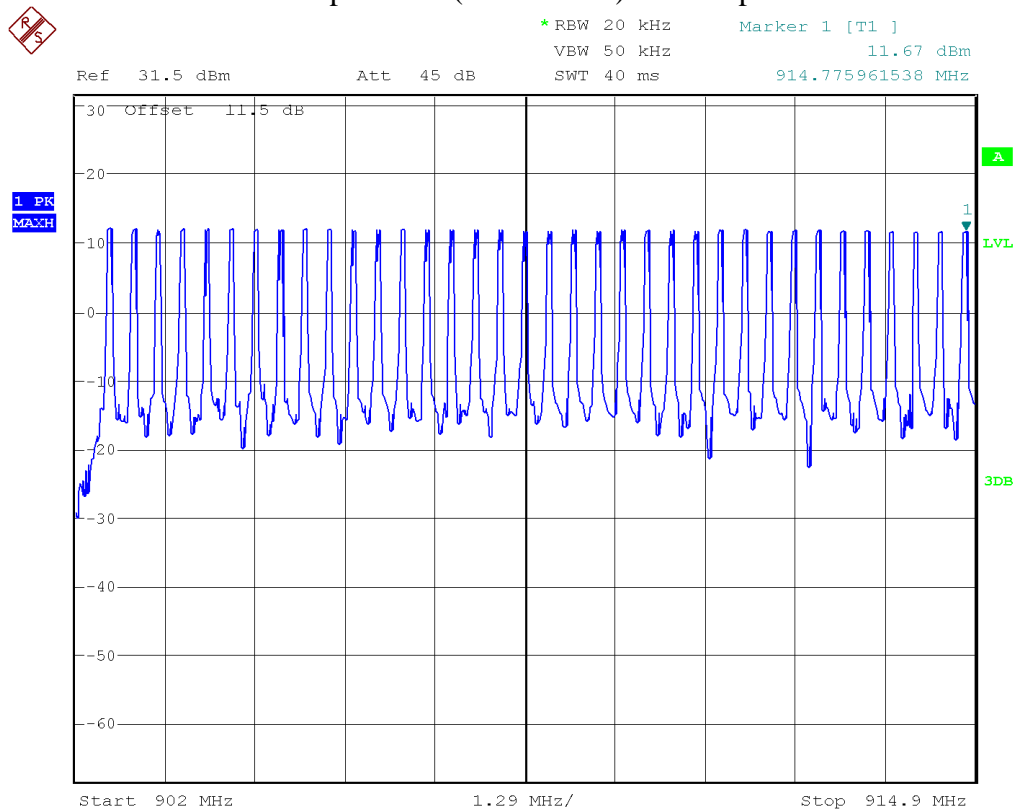

Date: 31.MAR.2016 16:05:59

Client	Ecobee Inc	
Product	Athena RS Gen 2	
Standard(s)	RSS 247: 2015 / FCC Part 15 Subpart C 15:2016	

Graph 2 of 2 (36 channels): 38.4 kbps

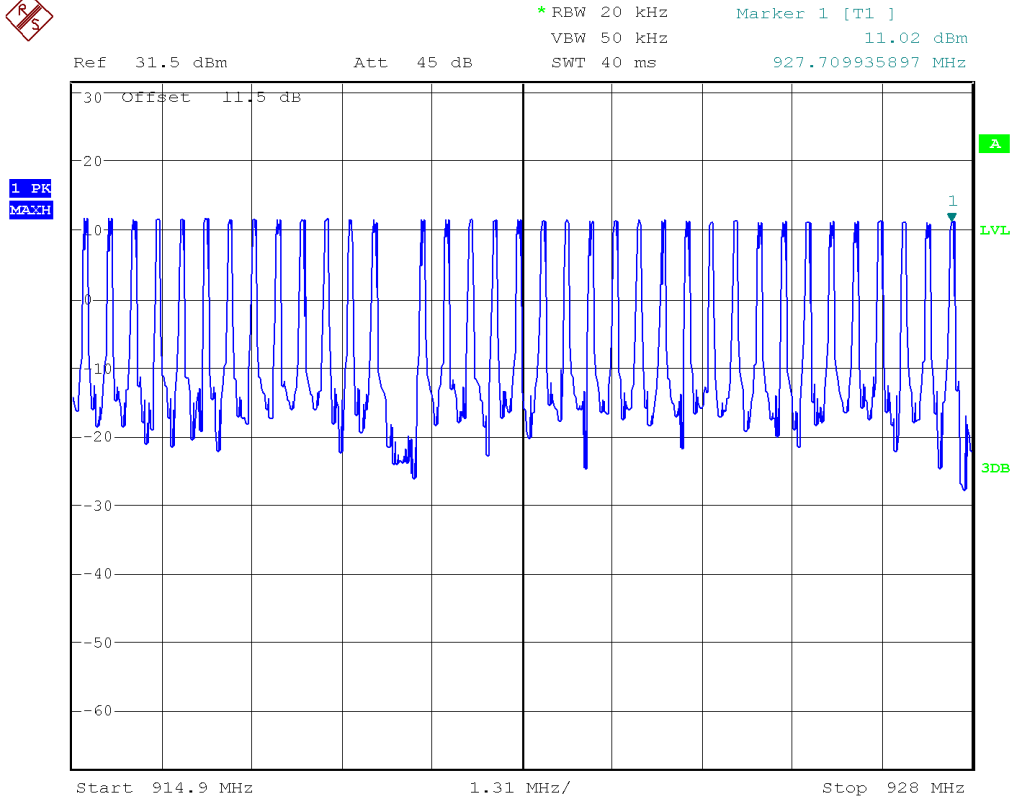

Date: 31.MAR.2016 16:14:53

Client	Ecobee Inc	
Product	Athena RS Gen 2	
Standard(s)	RSS 247: 2015 / FCC Part 15 Subpart C 15:2016	

Graph 1 of 2 (36 channels): 500 kpbs

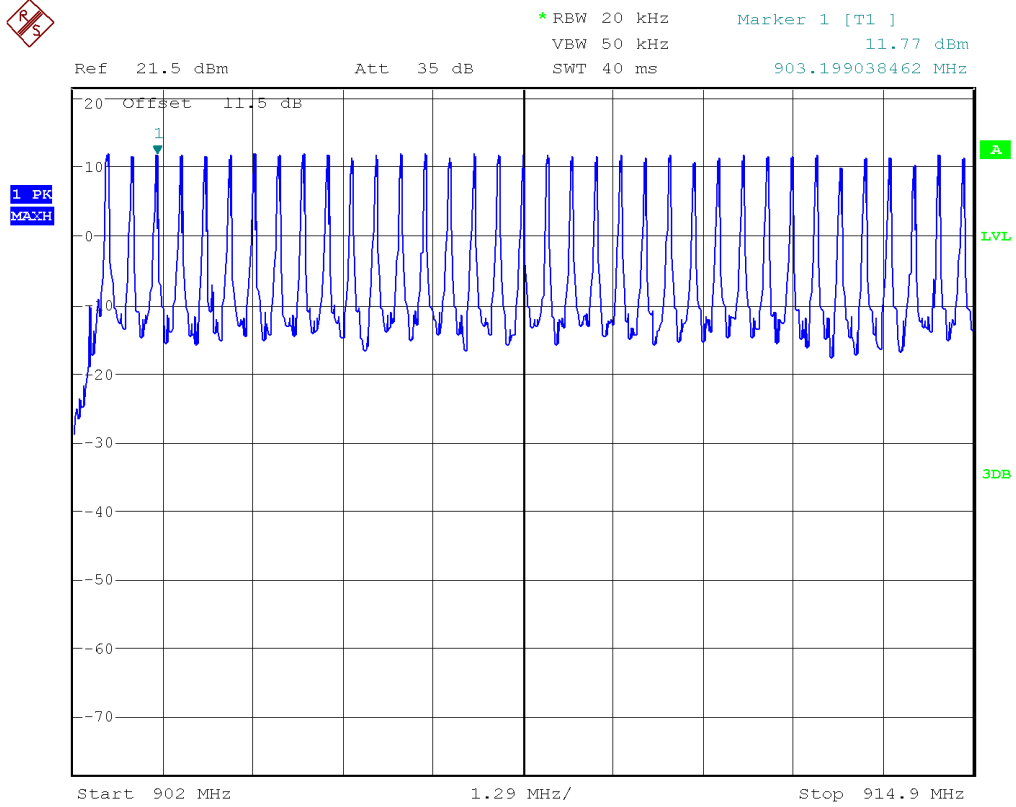

Date: 2.APR.2016 12:09:52

Client	Ecobee Inc	
Product	Athena RS Gen 2	
Standard(s)	RSS 247: 2015 / FCC Part 15 Subpart C 15:2016	

Graph 2 of 2 (35 more channels)

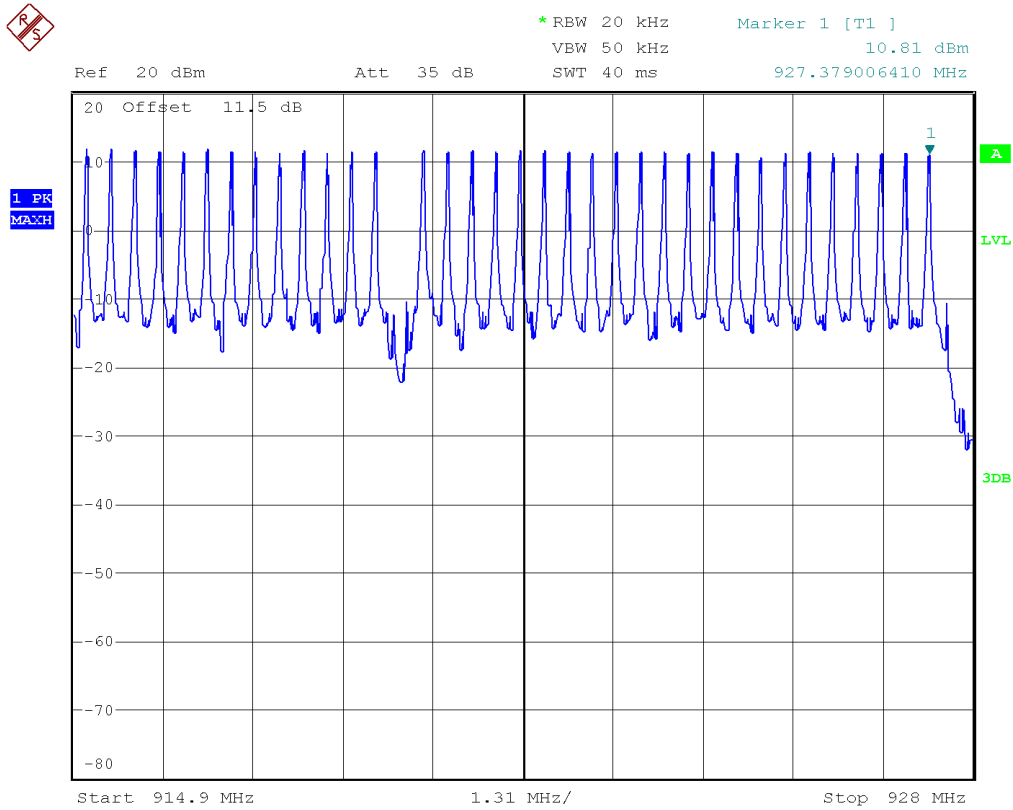

Date: 18.APR.2016 19:52:32

Note: See 'Appendix B – EUT & Test Setup Photographs' for photos showing the test set-up.

Client	Ecobee Inc	
Product	Athena RS Gen 2	
Standard(s)	RSS 247: 2015 / FCC Part 15 Subpart C 15:2016	

Test Equipment List

Equipment	Model No.	Manufacturer	Last calibration date	Next calibration due date	Asset #
Spectrum Analyzer	FSU	Rohde & Schwarz	Jan 19, 2015	Jan 19, 2017	GEMC 198
Attenuator 10 dB	8493B	Agilent	Feb 11, 2016	Feb 11, 2017	GEMC133

This report module is based on GEMC template "FCC – Power Line Conducted Emissions Class B_Rev1"

Client	Ecobee Inc	
Product	Athena RS Gen 2	
Standard(s)	RSS 247: 2015 / FCC Part 15 Subpart C 15:2016	

Time of Occupancy

Purpose

The purpose of this test is to ensure that the RF energy of frequency hopping systems is hopping at a minimum defined rate. This helps ensure sufficient time off to enable other frequency hopping devices to co-operate within this allocated band.

Limits and Methods

For 902 to 928 MHz systems, the limits are as defined in 47 CFR FCC Part 15 Section 15.247(a)(1)(i).

For frequency hopping systems operating in the 902-928 MHz band: if the 20 dB bandwidth of the hopping channel is less than 250 kHz, the system shall use at least 50 hopping frequencies and the average time of occupancy on any frequency shall not be greater than 0.4 seconds within a 20 second period; if the 20 dB bandwidth of the hopping channel is 250 kHz or greater, the system shall use at least 25 hopping frequencies and the average time of occupancy on any frequency shall not be greater than 0.4 seconds within a 10 second period. The maximum allowed 20 dB bandwidth of the hopping channel is 500 kHz.

The 20 dB bandwidth of the system is <250 kHz and have more than 50 channels; therefore the average time of occupancy on any frequency shall not be greater than 0.4 seconds within a 20 second period.

The test method is a defined in ANSI C63.10.

Results

The EUT passed the requirements. The maximum average time of occupancy is 0.25 seconds.

The transmit time for 38.4 kbps is 2.54 ms and for 500 kbps is 0.19 ms.

The analyzer sweep time is 400 ms.

There are 2 hops on the spectrum analyzer for 38.4 kbps and 3 hops for 500 kbps.

Number of hops in 20 s = (number of hops on spectrum analyzer) × (period specified in the requirements / analyzer sweep time)

Client	Ecobee Inc	
Product	Athena RS Gen 2	
Standard(s)	RSS 247: 2015 / FCC Part 15 Subpart C 15:2016	

Number of hops in 20 s (38.4 kbps) = $2 \times (20000/400) = 100$ hops

Number of hops in 20 s (500 kbps) = $3 \times (20000/400) = 150$ hops

Average time of occupancy (38.4 kbps) = $100 \times 2.54 \text{ ms} = 254 \text{ ms}$

Average time of occupancy (500 kbps) = $150 \times 0.19 \text{ ms} = 28.5 \text{ ms}$

Graph(s)

Transmit time per hop: 38.4 kbps

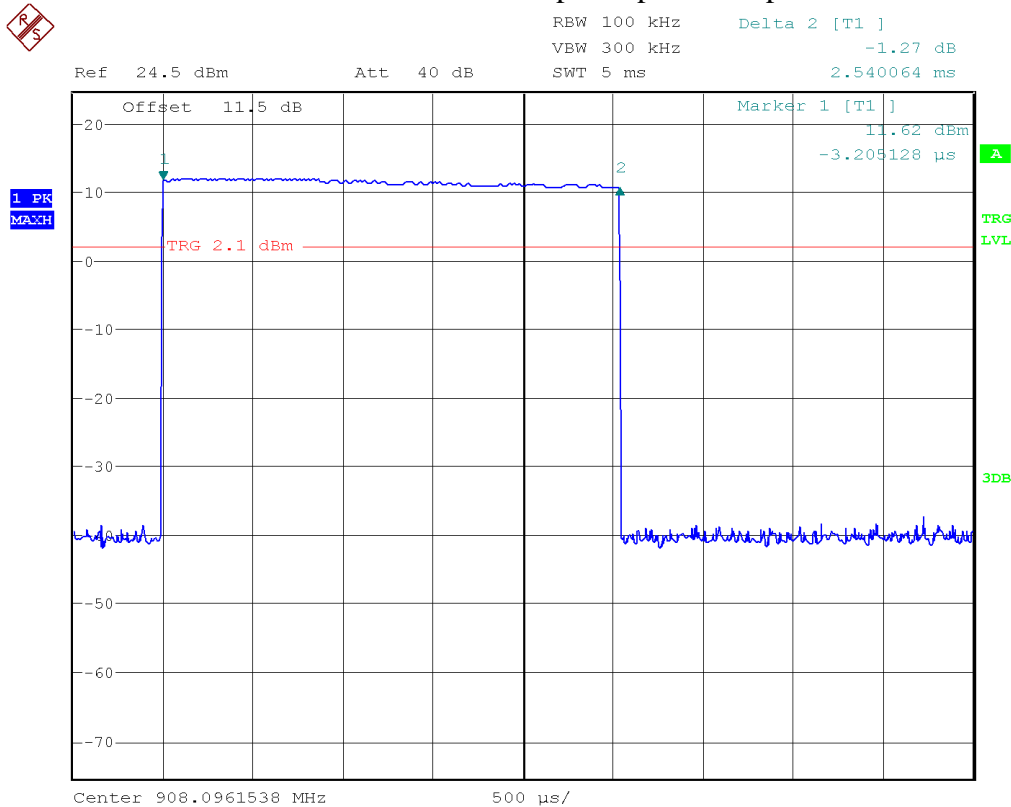

Date: 31.MAR.2016 16:42:10

Client	Ecobee Inc	
Product	Athena RS Gen 2	
Standard(s)	RSS 247: 2015 / FCC Part 15 Subpart C 15:2016	

Repetition Rate: 38.4 kbps

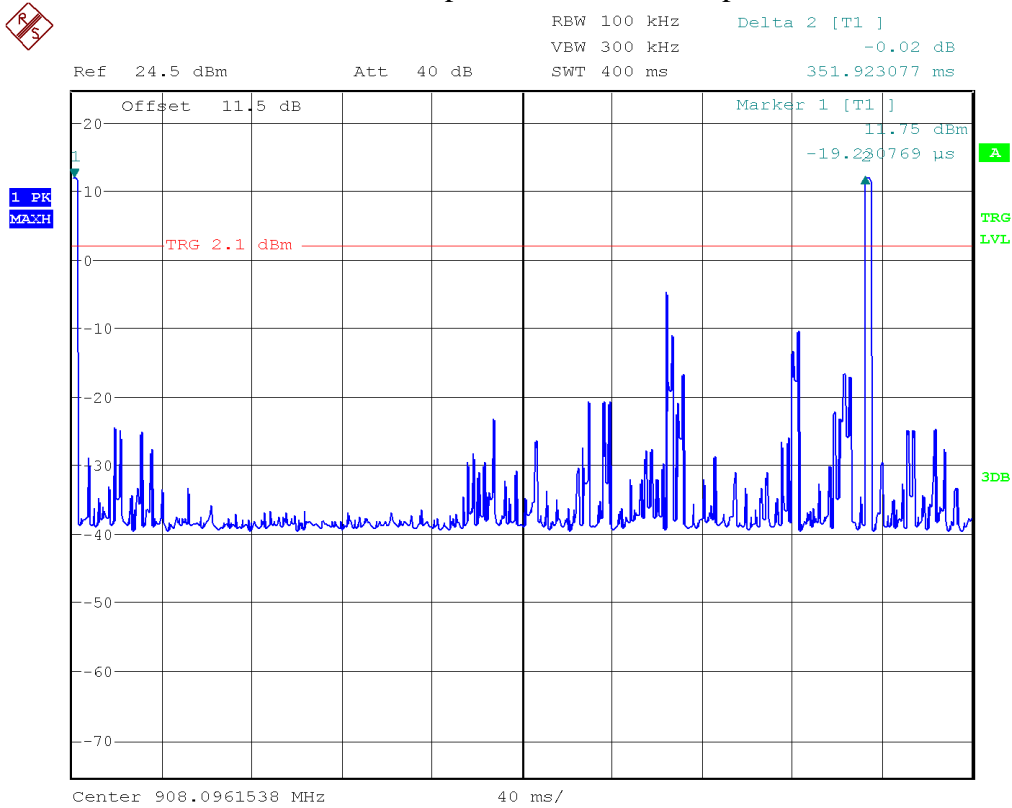

Date: 31.MAR.2016 16:39:47

Client	Ecobee Inc	
Product	Athena RS Gen 2	
Standard(s)	RSS 247: 2015 / FCC Part 15 Subpart C 15:2016	

Transmit time per hop: 500 kbps

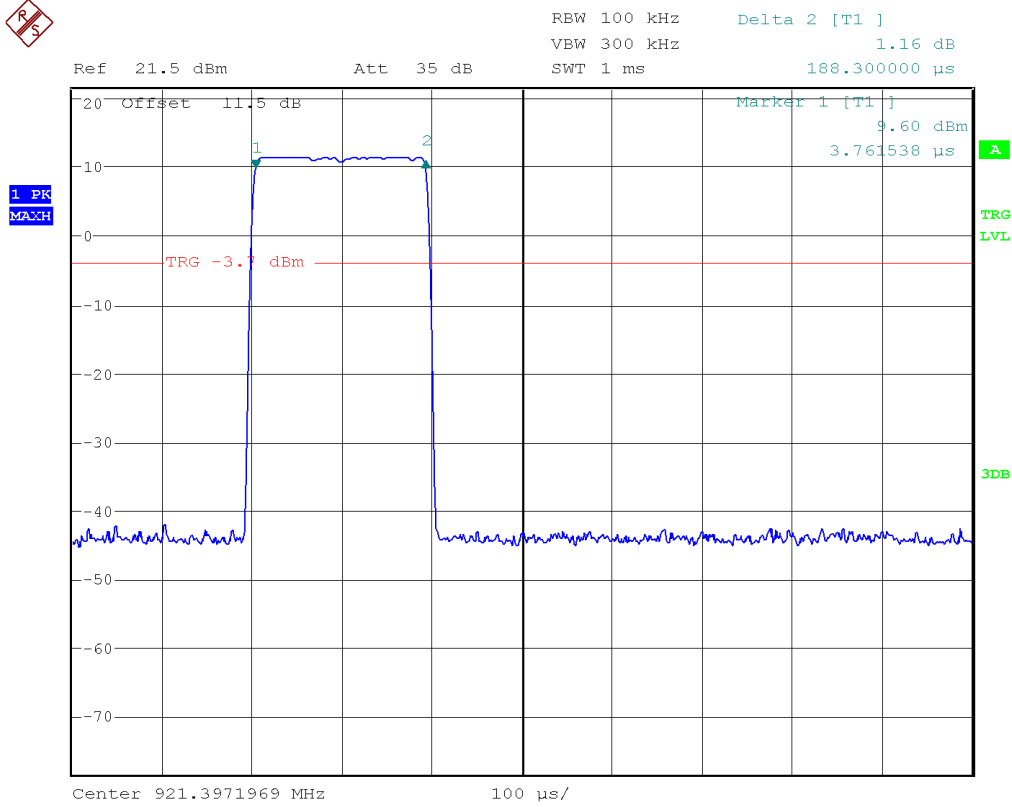

Date: 5.APR.2016 12:16:51

Client	Ecobee Inc	
Product	Athena RS Gen 2	
Standard(s)	RSS 247: 2015 / FCC Part 15 Subpart C 15:2016	

Repetition Rate: 500 kbps

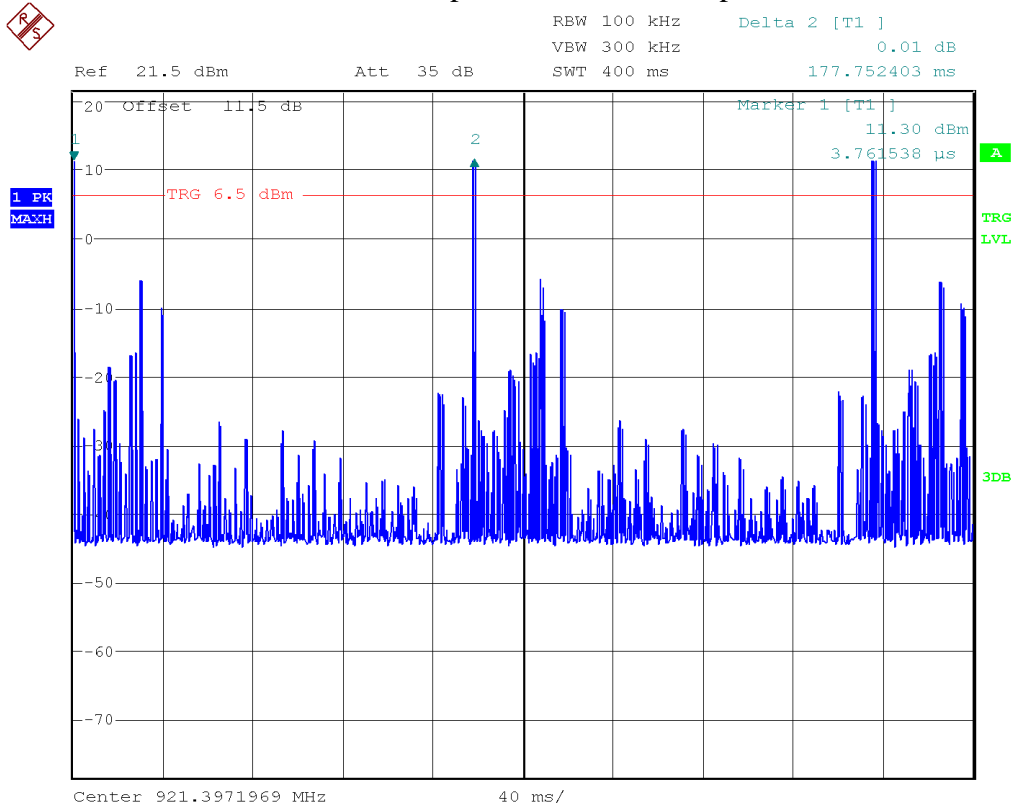

Date: 5.APR.2016 12:20:48

Note: See 'Appendix B – EUT & Test Setup Photographs' for photos showing the test set-up.

Test Equipment List

Equipment	Model No.	Manufacturer	Last calibration date	Next calibration due date	Asset #
Spectrum Analyzer	FSU	Rohde & Schwarz	Jan 19, 2015	Jan 19, 2017	GEMC 198
Attenuator 10 dB	8493B	Agilent	Feb 11, 2016	Feb 11, 2017	GEMC133

This report module is based on GEMC template "FCC – Power Line Conducted Emissions Class B_Rev1"

Client	Ecobee Inc	
Product	Athena RS Gen 2	
Standard(s)	RSS 247: 2015 / FCC Part 15 Subpart C 15:2016	

Maximum Peak Envelope Conducted Power - FHSS

Purpose

The purpose of this test is to ensure that the maximum power conducted to the radiating element does not exceed the limits specified.

Limits and methods

The limits are defined in 15.247(b).

For frequency hopping systems operating in the 902-928 MHz band: 1 watt for systems employing at least 50 hopping channels; and, 0.25 watts for systems employing less than 50 hopping channels, but at least 25 hopping channels, as permitted under paragraph (a)(1)(i) of this section.

The test method is a defined in ANSI C63.10.

Results

The EUT passed. The peak power measured was 12.16 dBm (16.44 mW).

38.4 kbps data rate			
Channel	Frequency (MHz)	Peak Power (dBm)	Peak Power (mW)
Low Channel	902.5	12.16	16.44
Mid Channel	915.1	11.74	14.93
High Channel	927.7	11.3	13.49

500 kbps data rate			
Channel	Frequency (MHz)	Peak Power (dBm)	Peak Power (mW)
Low Channel	902.5	12.14	16.37
Mid Channel	915.1	11.83	15.24
High Channel	927.4	11.44	13.93

Client	Ecobee Inc	
Product	Athena RS Gen 2	
Standard(s)	RSS 247: 2015 / FCC Part 15 Subpart C 15:2016	

Measurement(s)

The graph below shows the peak power output of the device during the antenna conducted measurement during transmit operation of the EUT.

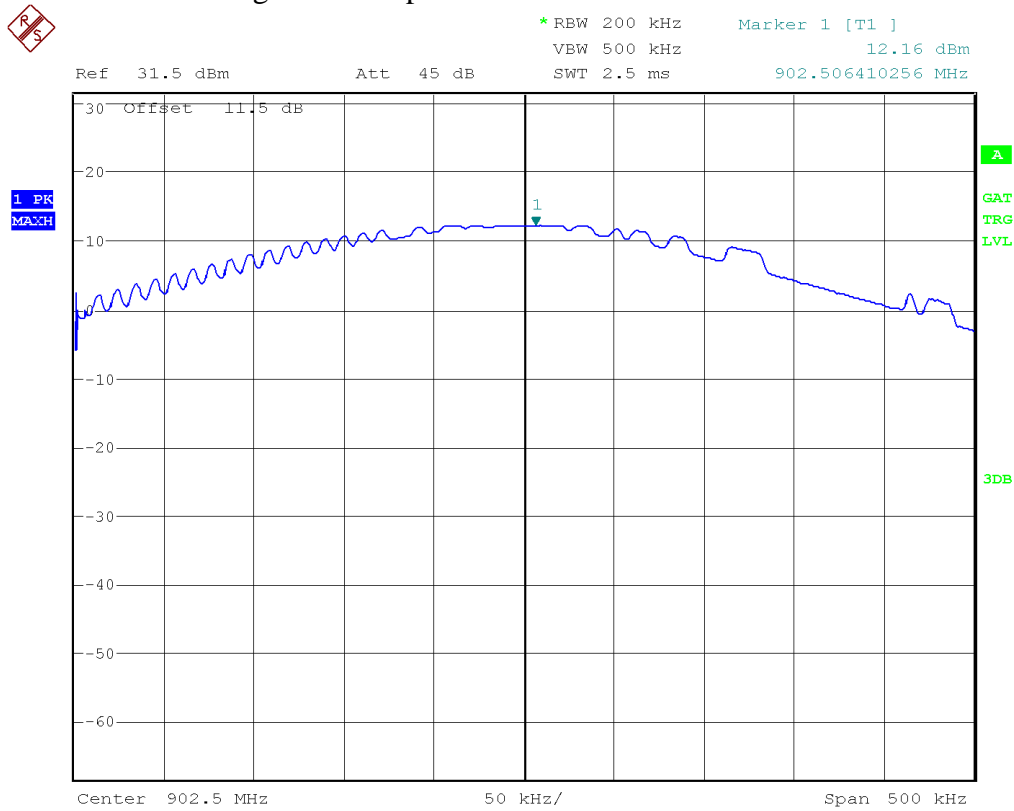

Date: 31.MAR.2016 18:07:35

Note: See 'Appendix B – EUT & Test Setup Photographs' for photos showing the test set-up.

Client	Ecobee Inc	
Product	Athena RS Gen 2	
Standard(s)	RSS 247: 2015 / FCC Part 15 Subpart C 15:2016	

Test Equipment List

Equipment	Model No.	Manufacturer	Last calibration date	Next calibration due date	Asset #
Spectrum Analyzer	FSU	Rohde & Schwarz	Jan 19, 2015	Jan 19, 2017	GEMC 198
Attenuator 10 dB	8493B	Agilent	Feb 11, 2016	Feb 11, 2017	GEMC133

This report module is based on GEMC template "FCC – Power Line Conducted Emissions Class B_Rev1"

Client	Ecobee Inc	
Product	Athena RS Gen 2	
Standard(s)	RSS 247: 2015 / FCC Part 15 Subpart C 15:2016	

Antenna Spurious Conducted Emissions (-20 dBc Requirement) – 15.247

Purpose

The purpose of this test is to ensure that the maximum power conducted to the radiating element at frequencies outside of the authorized spectrum does not exceed the limits specified. This ensures that the only the intended signal is delivered to the radiating element.

Limits and Methods

The limits are defined in 15.247(d). In any 100 kHz band, the peak spurious harmonics emissions must be at least 20 dB below the fundamental. Spurious Conducted emissions are to be evaluated up to the 10th harmonic. This -20 dBc requirement also applies at the ‘band edge’

The method is given in and ANSI C63.10

Results

The EUT passed the limits. Low, middle and high channels were measured. The worst case was presented as a graph for the spectrum.

The EUT have two data rates. The higher rate uses a larger frequency deviation which results in a larger bandwidth. The higher data rate have one less channel compared to the lower data rate version. Band edge measurements were shown for both data rates. The -20 dBc requirement is shown for the lower band edge at 902 MHz in the low band. The -20 dBc requirement is also shown for the higher band edge at 928 MHz in the high band.

Client	Ecobee Inc	
Product	Athena RS Gen 2	
Standard(s)	RSS 247: 2015 / FCC Part 15 Subpart C 15:2016	

Graph(s)

The graphs shown below shows the peak power output of the device during the antenna conducted measurement during transmit operation of the EUT.

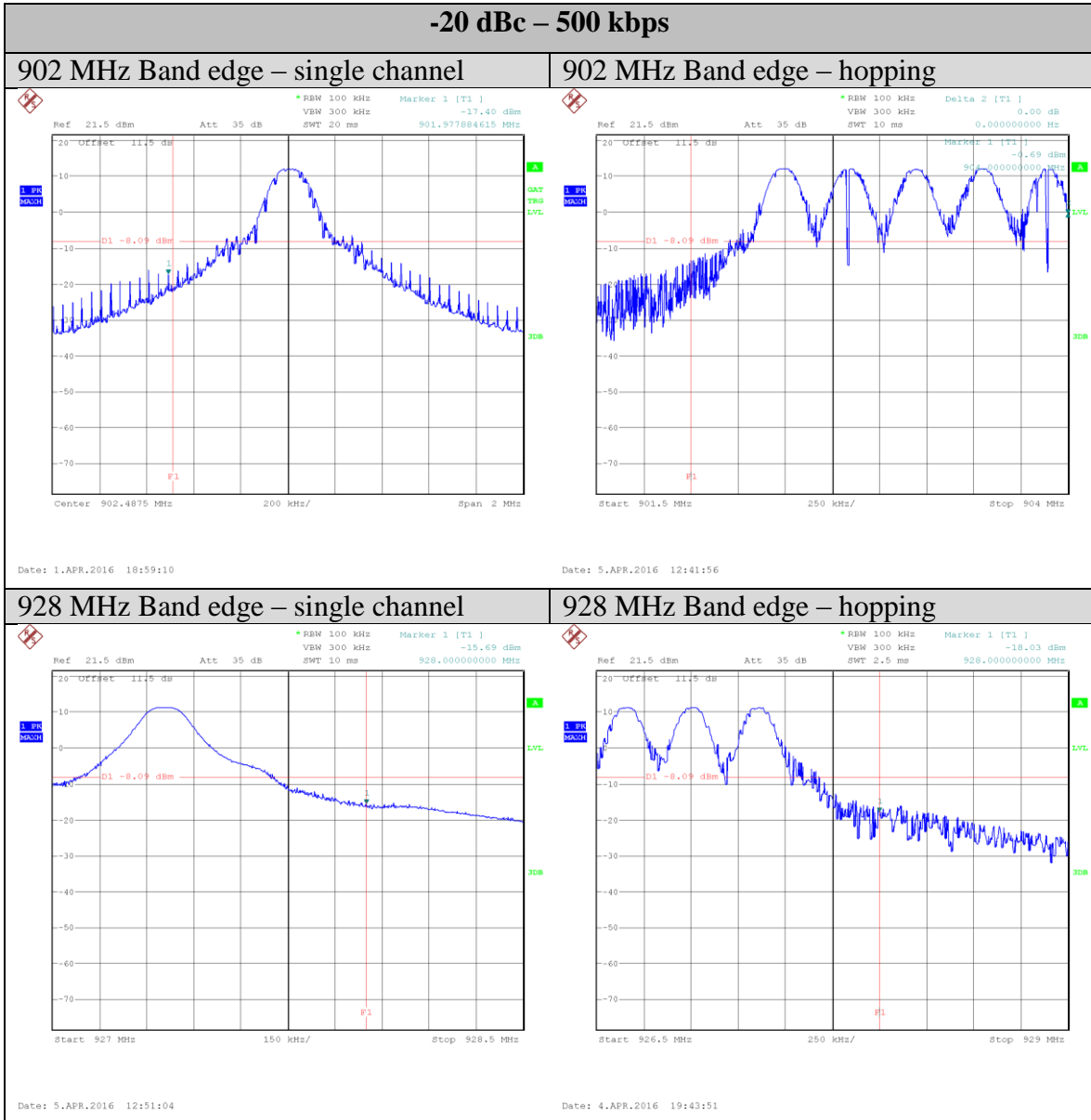

Client	Ecobee Inc	
Product	Athena RS Gen 2	
Standard(s)	RSS 247: 2015 / FCC Part 15 Subpart C 15:2016	

-20 dBc – 38.4 kbps

902 MHz Band edge – single channel	902 MHz Band edge – hopping
---	------------------------------------

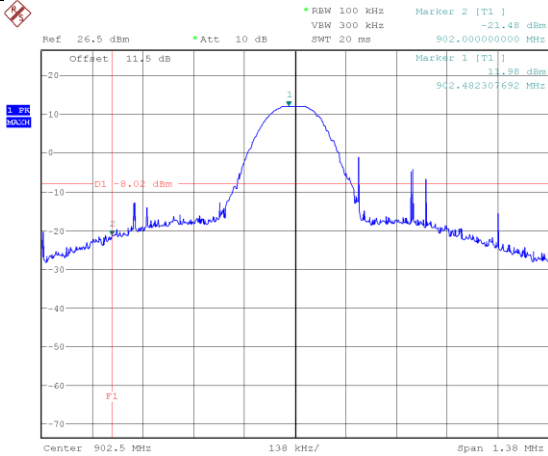

Date: 31.MAR.2016 18:20:16

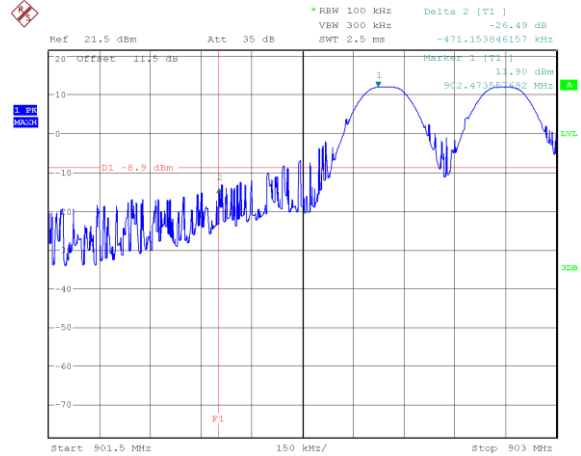

Date: 31.MAR.2016 16:56:18

928 MHz Band edge – single channel	928 MHz Band edge – hopping
---	------------------------------------

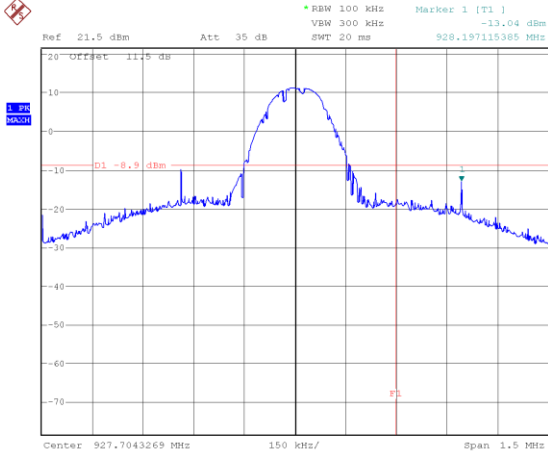

Date: 31.MAR.2016 17:17:58

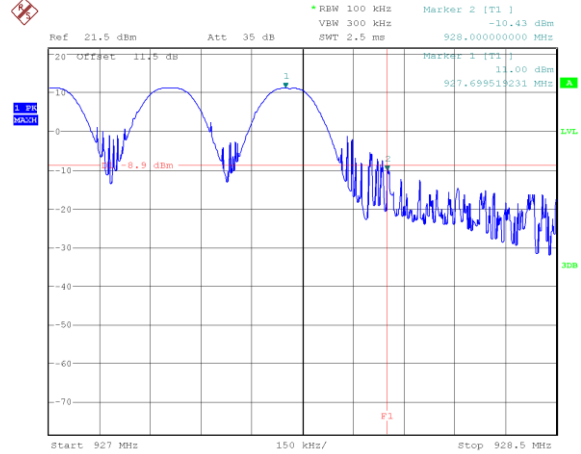

Date: 31.MAR.2016 16:59:15

Client	Ecobee Inc	
Product	Athena RS Gen 2	
Standard(s)	RSS 247: 2015 / FCC Part 15 Subpart C 15:2016	

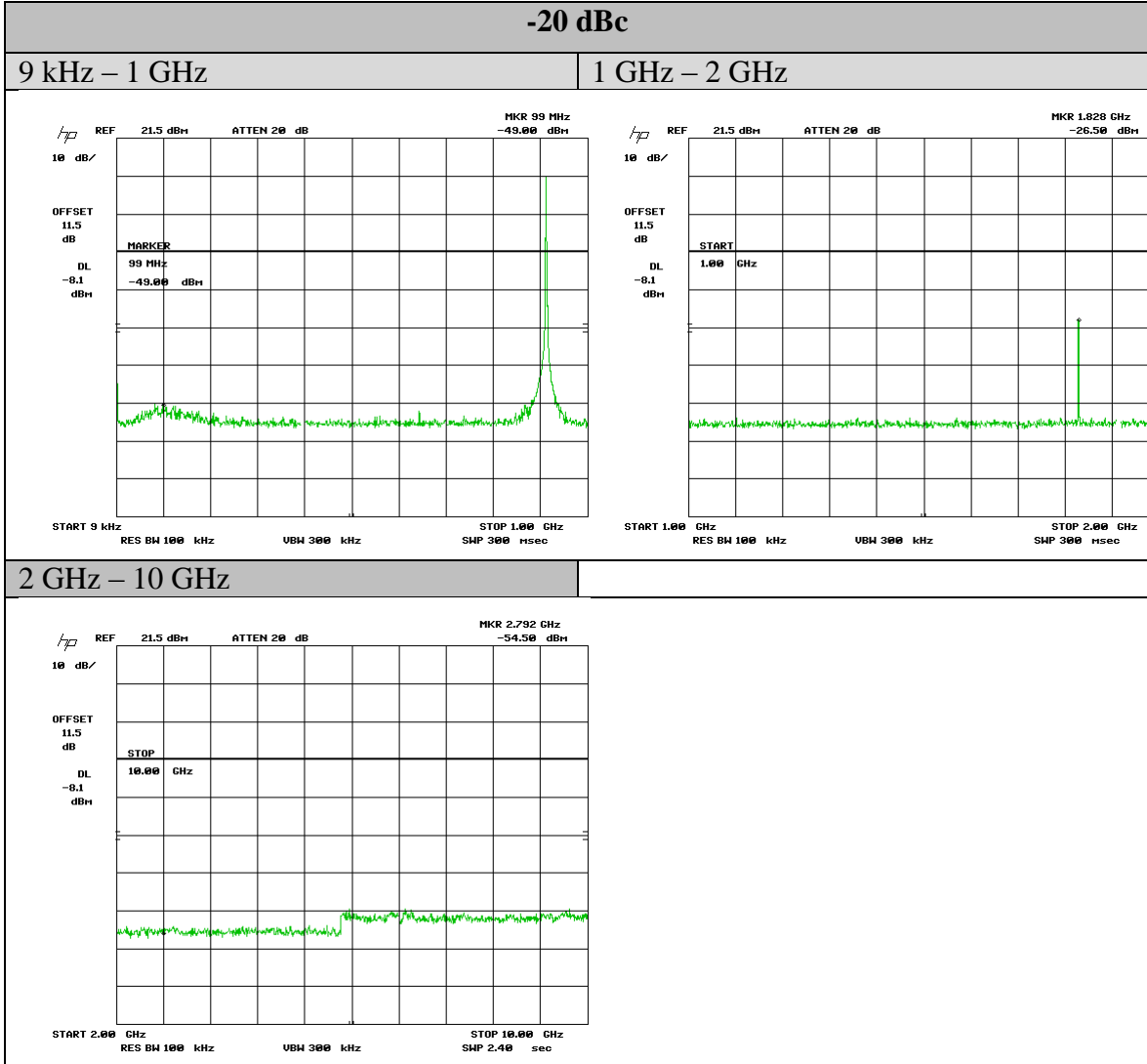

Note: See ‘Appendix B – EUT & Test Setup Photographs’ for photos showing the test set-up.

Client	Ecobee Inc	
Product	Athena RS Gen 2	
Standard(s)	RSS 247: 2015 / FCC Part 15 Subpart C 15:2016	

Test Equipment List

Equipment	Model No.	Manufacturer	Last calibration / Verification date	Next calibration/ Verification due date	Asset #
Spectrum Analyzer	8566B	HP	Nov 27, 2015	Nov 27, 2017	GEMC 190
Quasi Peak Adapter	85650A	HP	Nov 27, 2015	Nov 27, 2017	GEMC 191
Spectrum Analyzer	FSU	Rohde & Schwarz	Jan 19, 2015	Jan 19, 2017	GEMC 198
Attenuator 10 dB	8493B	Agilent	Feb-11, 2016	Feb-11, 2017	GEMC133

This report module is based on GEMC template "FCC – Power Line Conducted Emissions Class B_Rev1"

Client	Ecobee Inc	
Product	Athena RS Gen 2	
Standard(s)	RSS 247: 2015 / FCC Part 15 Subpart C 15:2016	

Radiated Emissions – 15.247

Purpose

The purpose of this test is to ensure that the RF energy unintentionally emitted from the EUT does not exceed the limits listed below as defined in the applicable test standard, as measured from a receiving antenna. This helps protect broadcast radio services such as television, FM radio, pagers, cellular telephones, emergency services, and so on, from unwanted interference.

Limit and Method

The method is given in Section 12.1 of FCC KDB 558074 and ANSI C 63.10

The limits are as defined in FCC Part 15, Section 15.209:

The limits, as defined in 15.247(d) for unintentional radiated emissions apply for those emissions that fall in the restricted bands, as defined in Section 15.205(a). These emissions must comply with the radiated emission limits specified in Section 15.209(a).

All unintentional emissions must also meet the ‘Spurious Conducted Emissions’ requirements of -20 dBc or greater. See also ‘Spurious Conducted Emissions’ for further details.

0.009 MHz – 0.490 MHz, 2400/F (kHz) uV/m at 300 m¹

0.490 MHz – 1.705 MHz, 24000/F (kHz) uV/m at 30 m¹

1.705 MHz – 30 MHz, 30 uV/m at 30 m¹

30 MHz – 88 MHz, 100 uV/m (40.0 dBuV/m¹) at 3 m

88 MHz – 216 MHz, 150 uV/m (43.5 dBuV/m¹) at 3 m

216 MHz – 960 MHz, 200 uV/m (46.0 dBuV/m¹) at 3 m

Above 960 MHz, 500 uV/m (54.0 dBuV/m¹) at 3 m

Above 1000 MHz, 500 uV/m (54 dBuV/m²) at 3m

Above 1000 MHz, 500 uV/m (74 dBuV/m³) at 3m

¹Limit is with Quasi Peak detector with bandwidths as defined in CISPR-16-1-1

²Limit is with 1 MHz measurement bandwidth and using an Average detector

³Limit is with 1 MHz measurement bandwidth and using a Peak detector

Client	Ecobee Inc	
Product	Athena RS Gen 2	
Standard(s)	RSS 247: 2015 / FCC Part 15 Subpart C 15:2016	

Typical Radiated Emissions Setup

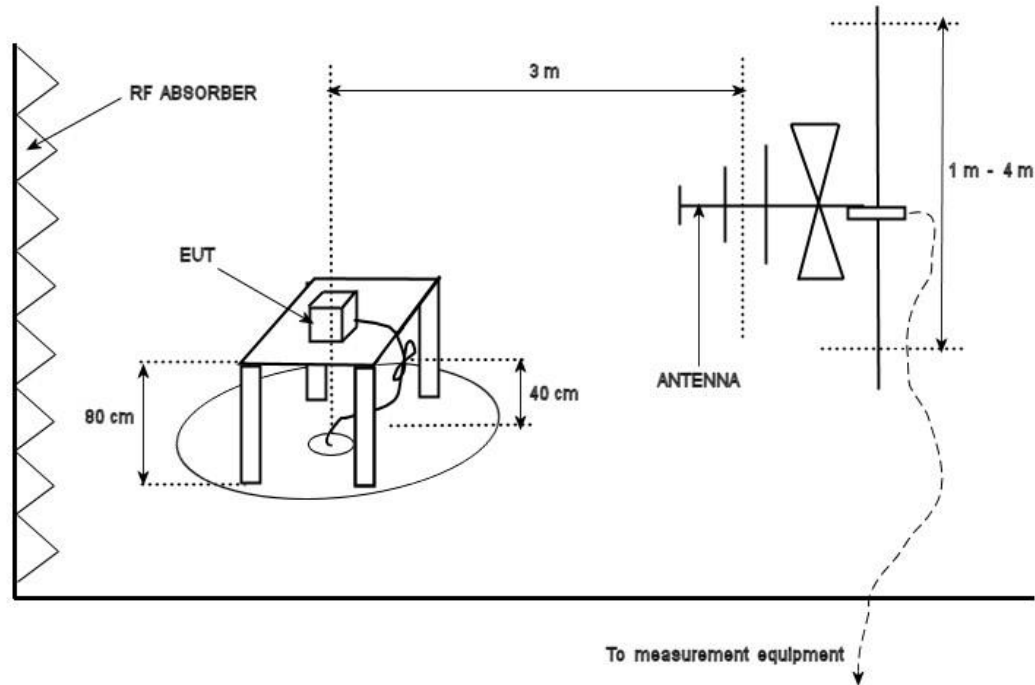

Measurement Uncertainty

The expanded measurement uncertainty is calculated in accordance with CISPR 16-4-2 and is +/-4.4 dB with a 'k=2' coverage factor and a 95% confidence level.

Preliminary Graphs

Note the graphs shown below are for graphical illustration only. For final measurements with the appropriate detector, please refer to the final measurement table where applicable. The graph shown below is a maximized peak measurement graph, measured with a resolution bandwidth greater than the final required detector and over a full 0-360 rotation. This peaking process is done as a worst case measurement. This process enables the detection of frequencies of concern for final measurement, and provides considerable time savings.

In accordance with FCC Part 15, Subpart A, Section 15.33, the device was scanned to the 10th harmonic (a minimum of a 24.835 GHz).

Client	Ecobee Inc	
Product	Athena RS Gen 2	
Standard(s)	RSS 247: 2015 / FCC Part 15 Subpart C 15:2016	

Devices scanned may be scanned at alternate test distances, and in accordance with FCC Part 15, Subpart A, Section 15.31, an extrapolation factor of 20 dB/decade was used above 30 MHz and 40 dB/decade below 30 MHz. For example for 1 meter measurements, an extrapolation factor 9.5 dB from 20 Log (1m / 3m) is applied.

Low, middle and high channels were measured, each in three orthogonal axes were checked; however the worst case graphs are presented.

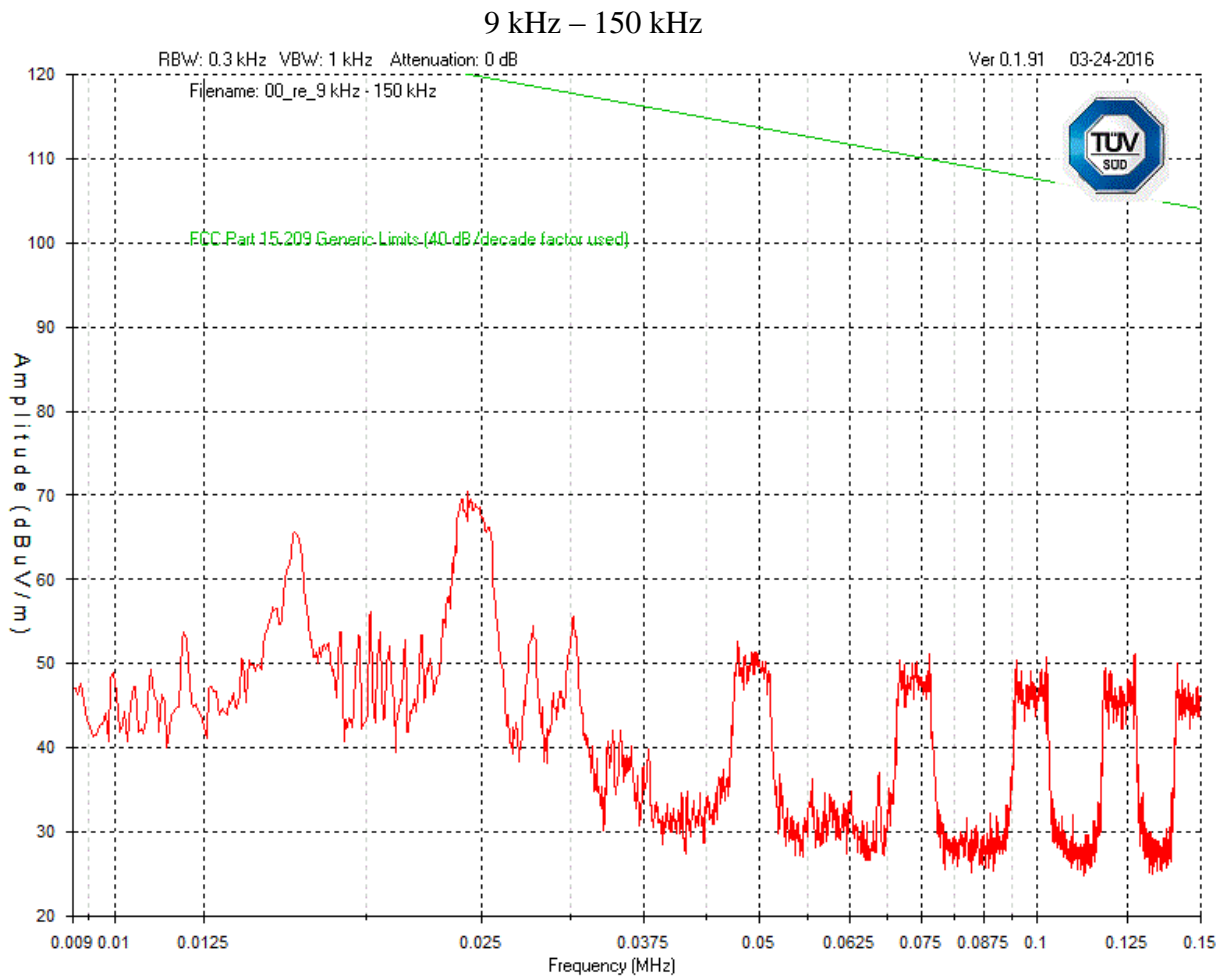

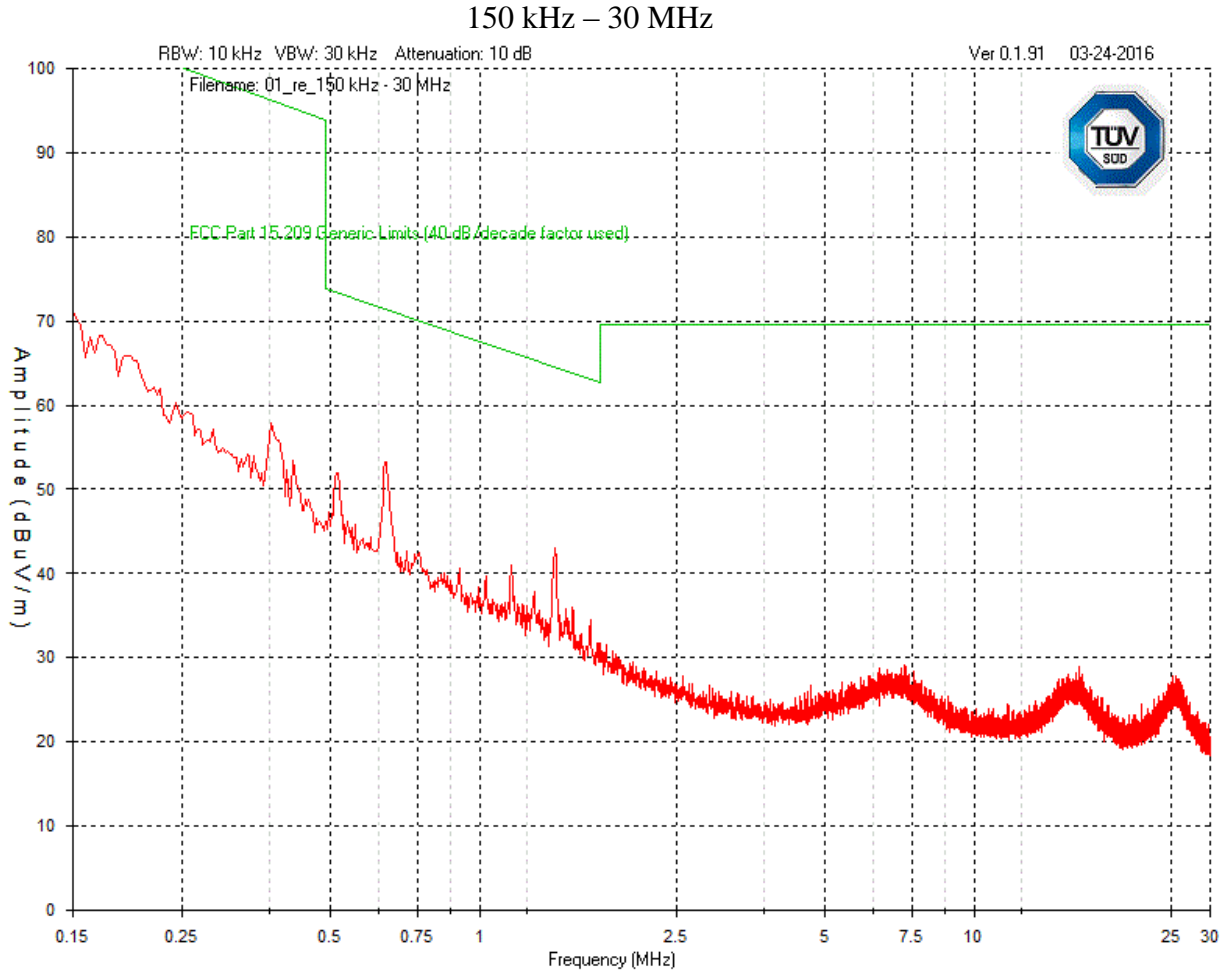

Client	Ecobee Inc	
Product	Athena RS Gen 2	
Standard(s)	RSS 247: 2015 / FCC Part 15 Subpart C 15:2016	

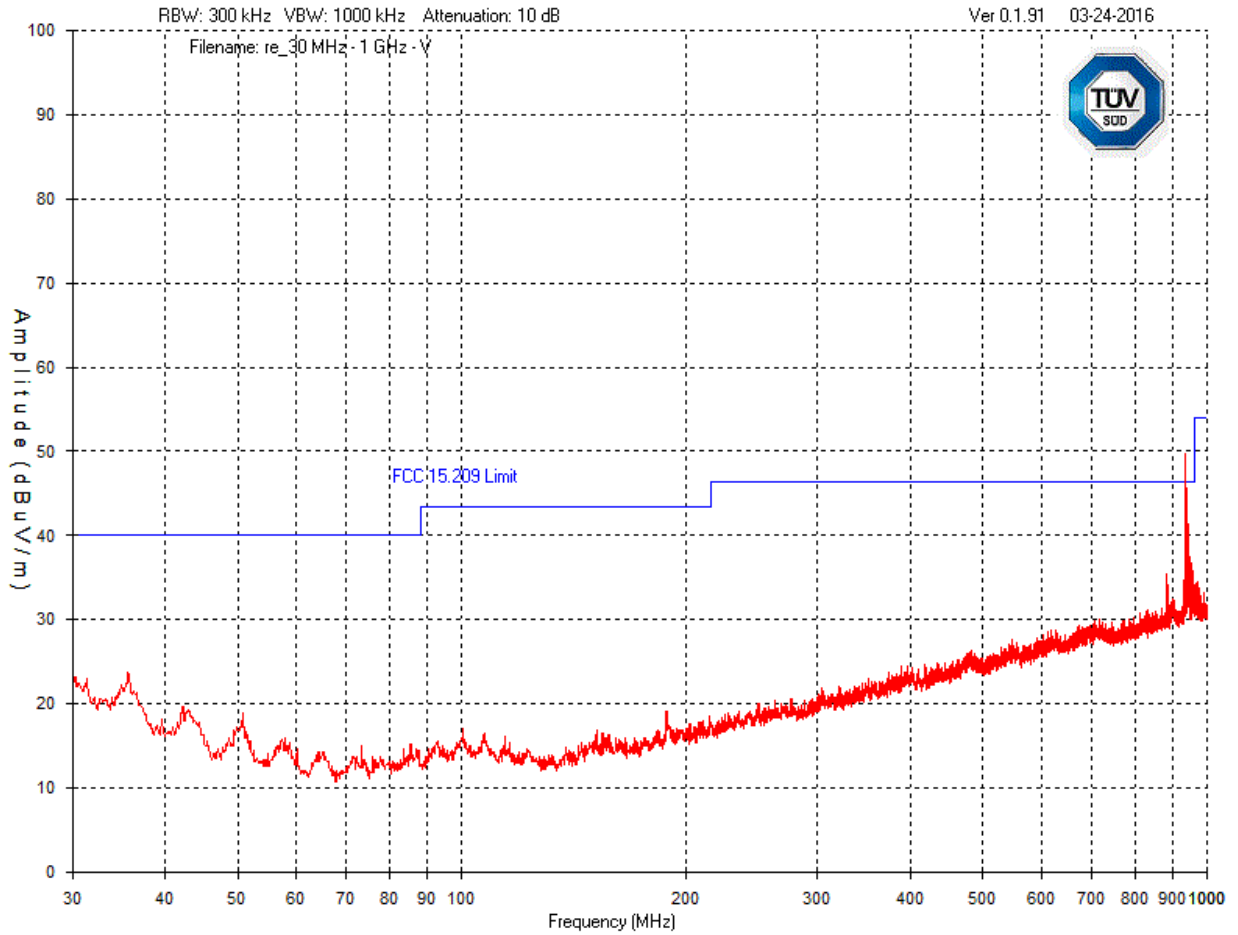

Client	Ecobee Inc	
Product	Athena RS Gen 2	
Standard(s)	RSS 247: 2015 / FCC Part 15 Subpart C 15:2016	

Mid Channel - 30 MHz – 1 GHz
Vertical – Peak Emission Graph



Client	Ecobee Inc	
Product	Athena RS Gen 2	
Standard(s)	RSS 247: 2015 / FCC Part 15 Subpart C 15:2016	

Mid Channel – 30 MHz – 1 GHz
Horizontal - Peak Emission Graph

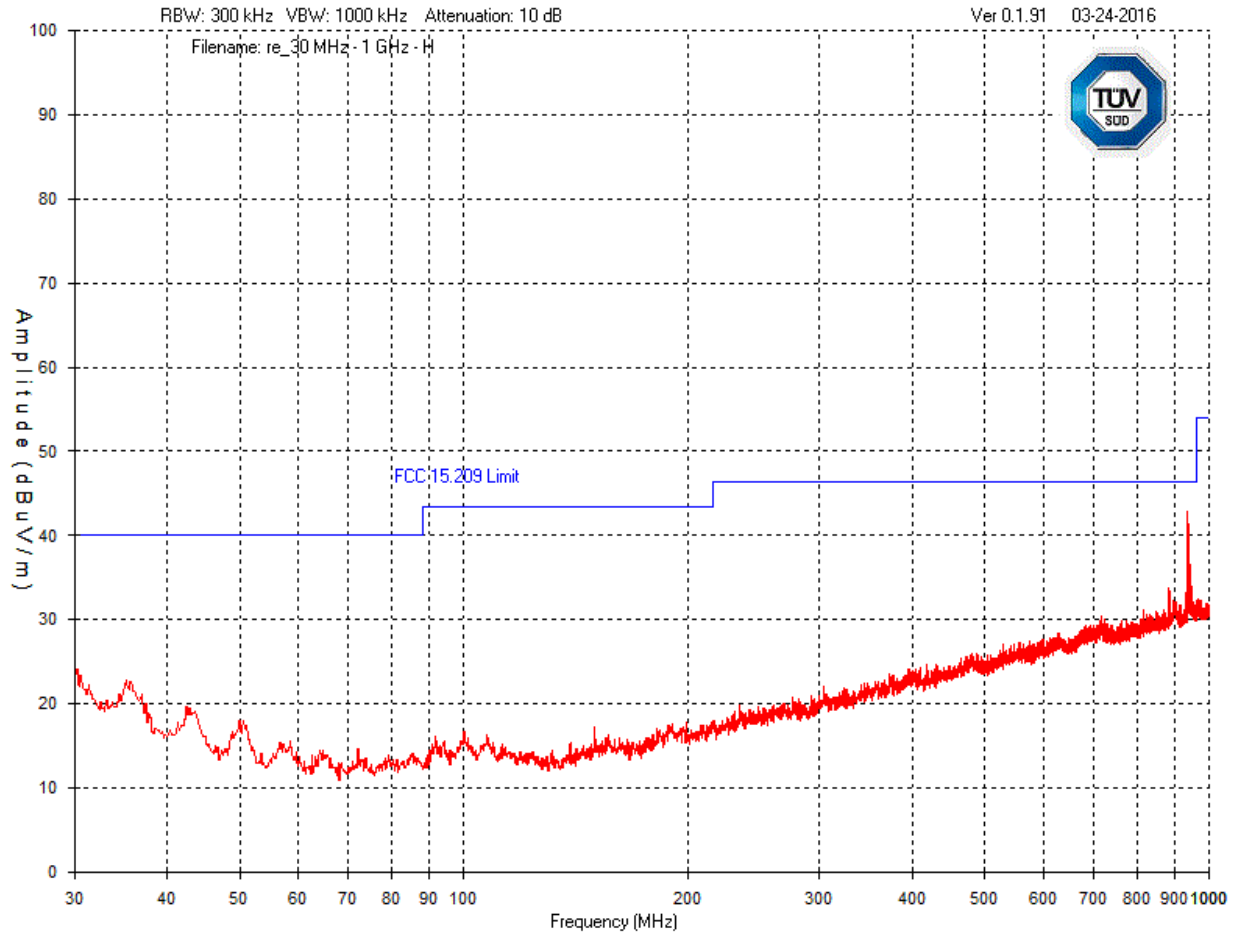

Client	Ecobee Inc	
Product	Athena RS Gen 2	
Standard(s)	RSS 247: 2015 / FCC Part 15 Subpart C 15:2016	

Mid Channel – 1 GHz – 2 GHz
Vertical - Peak Emission Graph

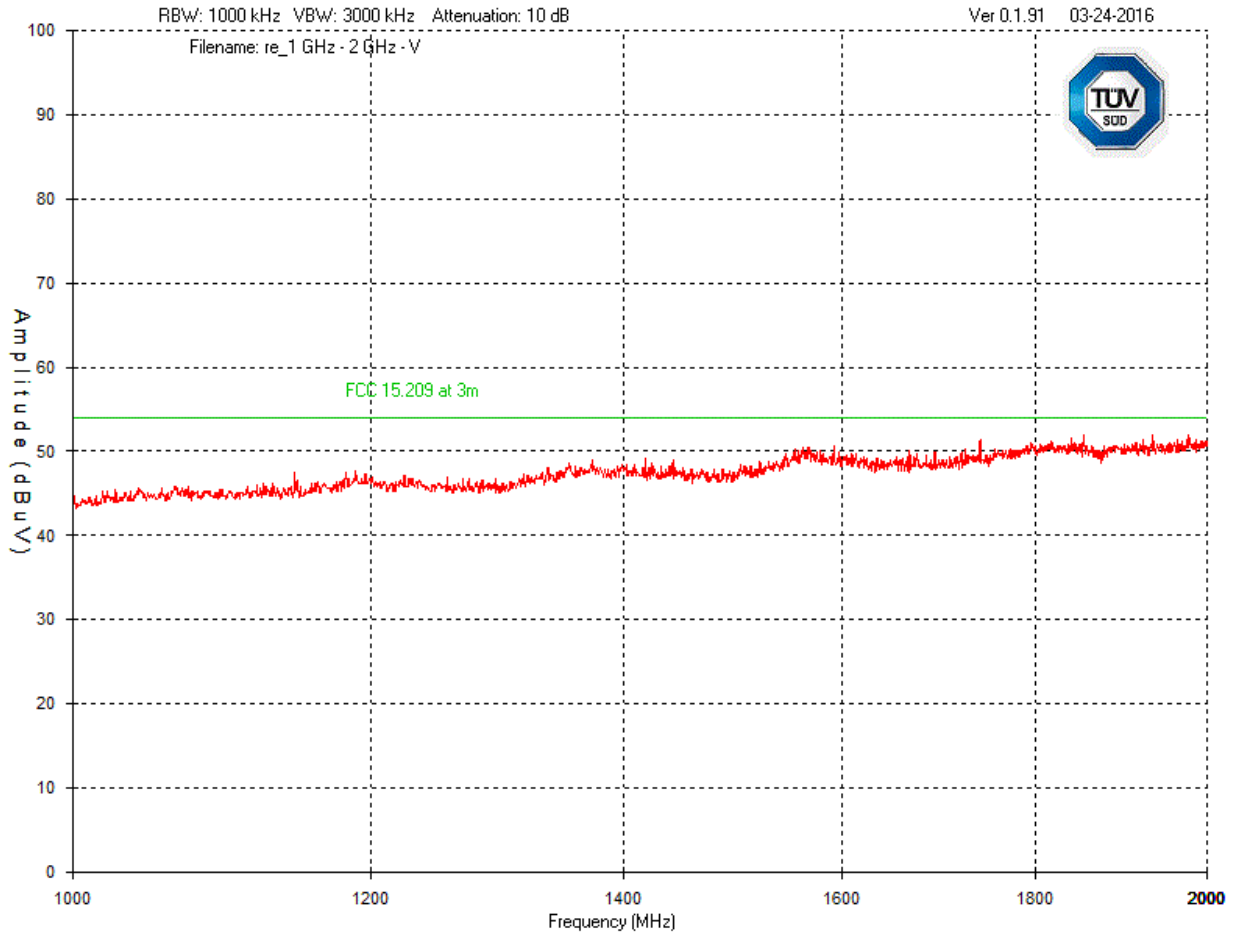

Client	Ecobee Inc	
Product	Athena RS Gen 2	
Standard(s)	RSS 247: 2015 / FCC Part 15 Subpart C 15:2016	

**Mid Channel – 1 GHz – 2 GHz
Horizontal - Peak Emission Graph**

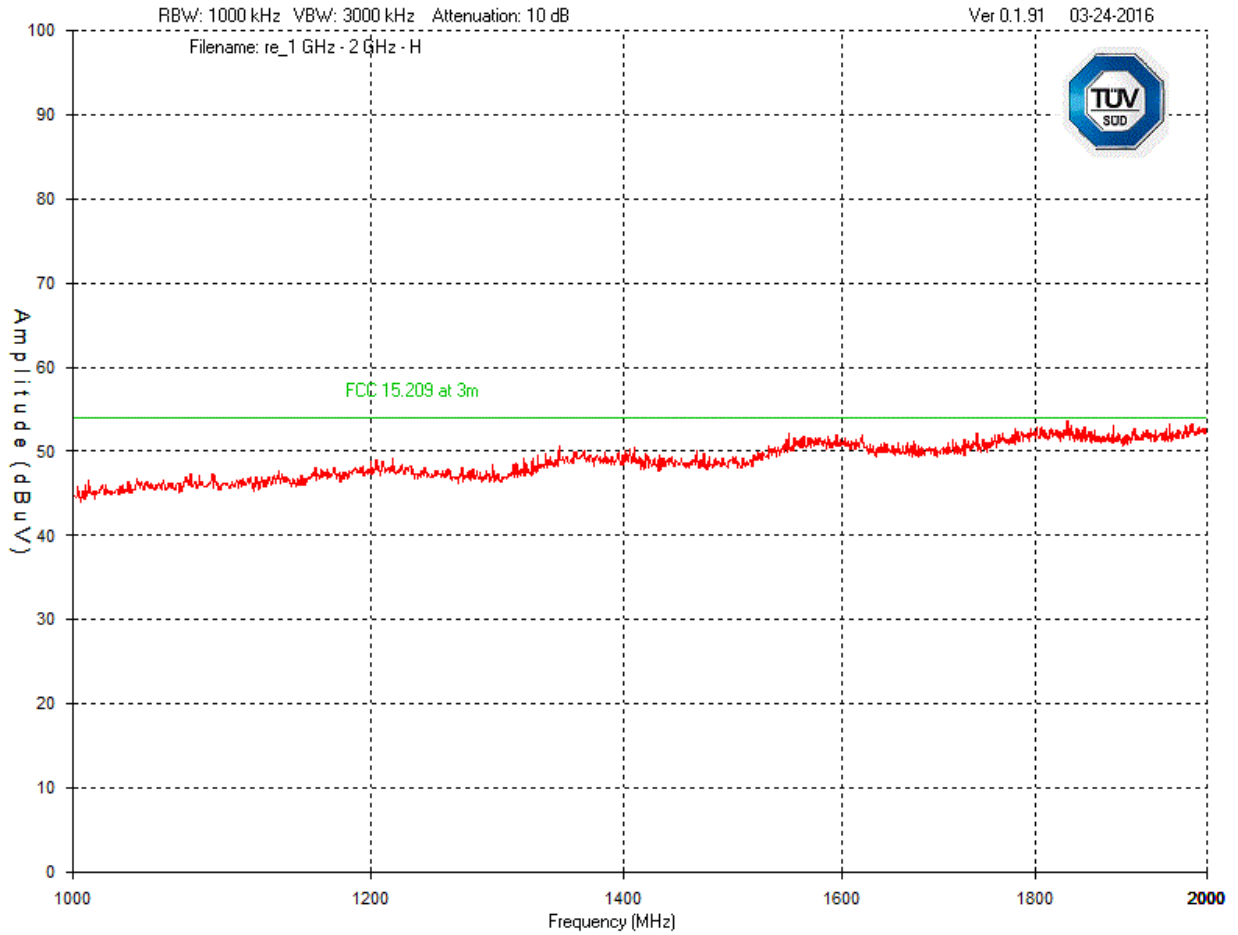

Client	Ecobee Inc	
Product	Athena RS Gen 2	
Standard(s)	RSS 247: 2015 / FCC Part 15 Subpart C 15:2016	

Mid Channel – 2 GHz – 10 GHz
Vertical - Peak Emission Graph

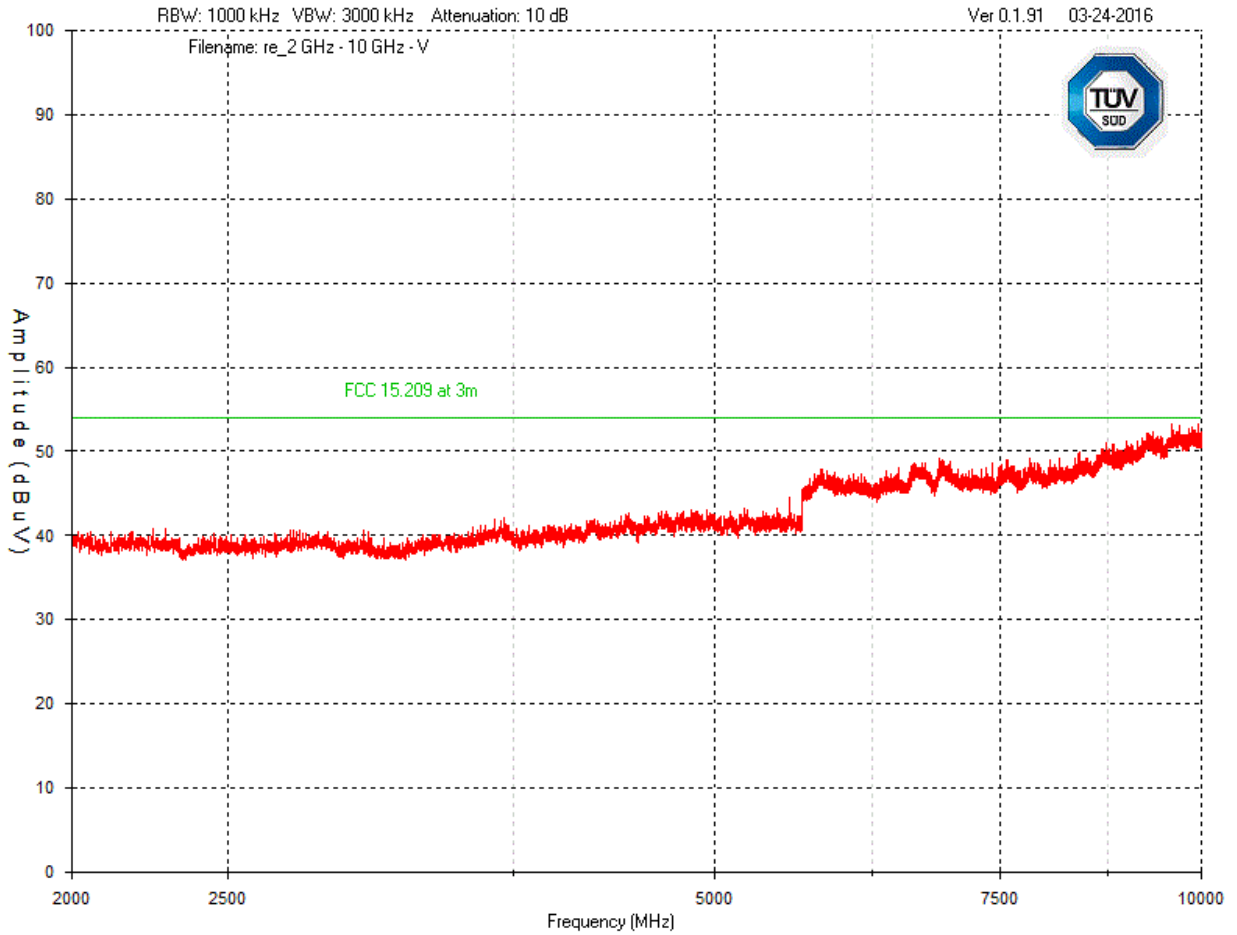

Note: See Final Measurements and Results section starting on page 50 for measurements.

Client	Ecobee Inc	
Product	Athena RS Gen 2	
Standard(s)	RSS 247: 2015 / FCC Part 15 Subpart C 15:2016	

Mid Channel – 2 GHz – 10 GHz
Horizontal - Peak Emission Graph

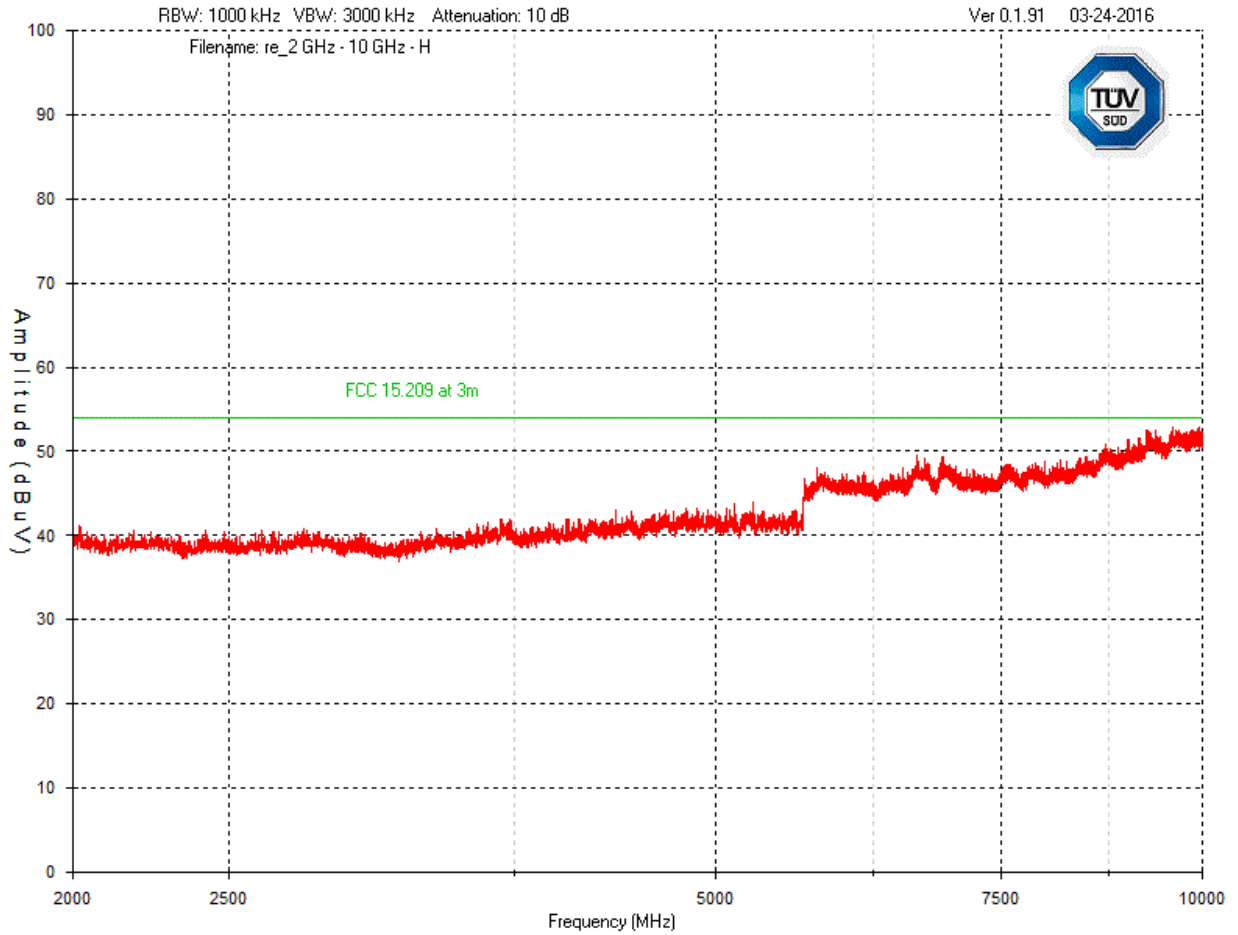

Note: See Final Measurements and Results section starting on page 50 for measurements.

Client	Ecobee Inc	
Product	Athena RS Gen 2	
Standard(s)	RSS 247: 2015 / FCC Part 15 Subpart C 15:2016	

Final Measurements and Results

The EUT passed the limits. Low, middle and high bands were measured.

In accordance with 15.247(d), only frequencies exceeding the 15.209 limit that occur within the bands listed in 15.205, need to be verified with a final detector. Emission outside the restricted bands were measured for information purpose.

The measurements were maximized by rotating the turn table over a full 0-360 rotation and the antenna height was varied from 1 m to 4 m.

Product Category	Class B						
Product	RS Gen 2						
Supply	Battery						
Vertical Emission Table							
Frequency (MHz)	Detector	Raw (dBuV)	Correction Factors (dB)	Level (dBuV/m)	Limit (dBuV/m)	Margin (dB)	Pass/Fail
934.525	QP	35.6	-4.4	31.2	46.4	15.2	Pass
937.144	QP	34.2	-4.4	29.8	46.4	16.6	Pass
1976.33	Peak	45.8	6.1	51.9	54.0	2.1	Pass
1854	Peak	46.4	5.5	51.9	54.0	2.1	Pass
1592.33	Peak	46.5	4.1	50.6	54.0	3.4	Pass
9941.67	AVG	39.5	4.9	44.4	54.0	9.6	Pass
Horizontal Emission Table							
935.01	PEAK	47.2	-4.4	42.8	46.4	3.6	Pass
936.174	PEAK	45.7	-4.4	41.3	46.4	5.1	Pass
1836	AVG,	39.5	7.5	47.0	54.0	7.0	Pass
9941.67	AVG	39.3	4.9	44.2	54.0	9.8	Pass

Client	Ecobee Inc	
Product	Athena RS Gen 2	
Standard(s)	RSS 247: 2015 / FCC Part 15 Subpart C 15:2016	

Test Equipment List

Equipment	Model No.	Manufacturer	Last calibration / Verification date	Next calibration/ Verification due date	Asset #
Spectrum Analyzer	8566B	HP	Nov 27, 2015	Nov 27, 2017	GEMC 190
Quasi Peak Adapter	85650A	HP	Nov 27, 2015	Nov 27, 2017	GEMC 191
Loop Antenna	EM 6871	Electro-Metrics	Feb 3, 2015	Feb 5, 2017	GEMC 70
Loop Antenna	EM 6872	Electro-Metrics	Feb 3, 2015	Feb 5, 2017	GEMC 71
BiLog Antenna	3142-C	ETS	Sept 8, 2014	Sept 8, 2016	GEMC 8
Attenuator 10 dB	8493B	Agilent	Feb 11, 2016	Feb 11, 2017	GEMC 133
Band Reject Filter	BRC50722	Micro-Tronics	NCR	NCR	GEMC 186
Chase Preamp 9kHz - 2 GHz	CPA9231A	Chase	Sept 9, 2014	Sept 9, 2016	GEMC 6403
Q-Par Horn Antenna (2 to 18 GHz)	WBH218HN	Q-par	Feb 12, 2016	Feb 12, 2018	GEMC 6375
1-26G pre-amp	HP 8449B	HP	Sept 9, 2014	Sept 9, 2016	GEMC 6351
RF Cable 7m	LMR-400-7M-50OHM-MN-MN	LexTec	Feb 1, 2016	Feb 1, 2017	GEMC 28
RF Cable 1m	LMR-400-1M-50OHM-MN-MN	LexTec	Feb 1, 2016	Feb 1, 2017	GEMC 29
RF Cable 0.5M	LMR-400-0.5M-50OHM-MN-MN	LexTec	Feb 1, 2016	Feb 1, 2017	GEMC 31

This report module is based on GEMC template "FCC - 15.209 - Radiated Emissions_Rev1.doc"

Client	Ecobee Inc	
Product	Athena RS Gen 2	
Standard(s)	RSS 247: 2015 / FCC Part 15 Subpart C 15:2016	

RF Exposure

Purpose

The purpose of this test is to ensure that the RF energy intentionally transmitted, in terms of power density emitted from the EUT at a stated operating distance does not exceed the limits listed below as defined in the applicable test standard, as calculated based upon readings obtained during testing. This helps protect human exposure to excessive RF fields.

Limit(s) and Method

The limits, as defined FCC 1.1310 Table 1 (B) limits for general public exposure was applied. The limits for the frequency ranges 300 MHz to 1.5 GHz and 1.5 GHz to 100 GHz was applied. The limits are $f/1500$ mW/cm² and 1.0 mW/cm² respectively.

As per FCC KDB 447498, Clause 4.3.1 b), the 1-g SAR exclusion threshold for 200 mm test distance is 1060 mW (see below for calculations).

For RSS 102 the RF exposure exemption limit for a 902 MHz transmitter is $1.31 \times 10^{-2} f^{0.6834}$ W which is 1.37 W.

The distance used for calculations was 20 cm, as this is the minimum distance an operator will be from the EUT during normal operation, as stated by the manufacturer.

Results

The EUT meets the requirements.

For FCC, the worst case calculated power density was 0.005 mW/cm², this is significantly under the 0.6 mW/cm² requirement.

For FCC SAR exemption, the maximum power the device transmits is 12.16 mW which is less than 1060 mW; therefore, the EUT meets SAR testing exclusion requirements.

For RSS 102, the E.I.R.P of the EUT is 12.16 dBm + 2 dBi = 14.16 dBm (0.026 W) which is significantly less than the 1.37 W exemption limit.

Client	Ecobee Inc	
Product	Athena RS Gen 2	
Standard(s)	RSS 247: 2015 / FCC Part 15 Subpart C 15:2016	

Calculations – Power Density

Method 1 (conducted power)

Internal antenna

$$P_d = (P_t * G) / (4 * \pi * R^2)$$

Where $P_t = 12.16$ dBm or 16.44 mW as per Peak power conducted output

Where $G = 2$ dBi, or numerically 1.58

Where $R = 20$ cm

$$P_d = (16.44 \text{ mW} * 1.58) / (4 * \pi * 20\text{cm}^2)$$

$$P_d = 25.97 \text{ mW} / 5026 \text{ cm}^2$$

$$P_d = 0.005 \text{ mW/cm}^2$$

Calculations – SAR Exclusion Limit

According to FCC KDB 447498, Clause 4.3.1 a) the exclusion power for up to 50 mm is

$$\text{Power @ 50 mm} = (3 * \text{distance}) / \sqrt{f(\text{GHz})}$$

$$\text{Power @ 50 mm} = (3 * 50) / \sqrt{0.902}$$

$$\text{Power @ 50 mm} = 158 \text{ mW}$$

According to FCC KDB 447498, Clause 4.3.1 b), the test exclusion power for above 50 mm is

$$\text{Power @ 50 mm} + (\text{dist} - 50 \text{ mm}) \times \left(\frac{f(\text{MHz})}{150} \right)$$

The exclusion power for 200 mm is therefore

$$158 \text{ mW} + ((200 \text{ mm} - 50 \text{ mm}) * (902 \text{ MHz} / 150)) = 1060 \text{ mW}$$

Client	Ecobee Inc	
Product	Athena RS Gen 2	
Standard(s)	RSS 247: 2015 / FCC Part 15 Subpart C 15:2016	

Appendix A – EUT Summary

Client	Ecobee Inc	
Product	Athena RS Gen 2	
Standard(s)	RSS 247: 2015 / FCC Part 15 Subpart C 15:2016	

For further details for filing purposes, refer to filing package.

General EUT Description

Client	
Organization	Ecobee Inc 250 University Avenue, Suite 400 Toronto, ON M5H 3E5
Contact	Kashif Ahmed
Phone	416 987 1048
Email	kashif@ecobee.com
EUT Details	
EUT Name (for report title)	Athena RS
EUT Model / SN (if known)	
FCC ID	WR9EBRSE4
Industry Canada #	7981A- EBRSE4
Equipment category	Wireless temperature and room occupancy sensor
EUT is powered using	Battery
Input voltage range(s) (V)	3.3 VDC
Transmits RF energy? (describe)	Yes
Basic EUT functionality description	Ecobee 3 temperature sensor

Note the EUT is considered to have been received the date of the commencement of the first test, unless otherwise stated. For a close-up picture of the EUT, see ‘Appendix B – EUT & Test Setup Photographs’.

Client	Ecobee Inc	
Product	Athena RS Gen 2	
Standard(s)	RSS 247: 2015 / FCC Part 15 Subpart C 15:2016	

EUT Configuration

Please see Appendix B for a picture of the unit running in normal conditions.

- Wireless were configured to transmit at maximum possible duty cycle
- The 15.247 902 – 928 MHz transmitter were configure with the following settings:

Operational Setup

These devices are required to be attached to the EUT for its normal operation.

- Non

Client	Ecobee Inc	
Product	Athena RS Gen 2	
Standard(s)	RSS 247: 2015 / FCC Part 15 Subpart C 15:2016	

Appendix B – EUT and Test Setup Photographs

Client	Ecobee Inc	
Product	Athena RS Gen 2	
Standard(s)	RSS 247: 2015 / FCC Part 15 Subpart C 15:2016	

Note: These photos are for information purposes only. Also refer to PDF files that are separate from this test report.

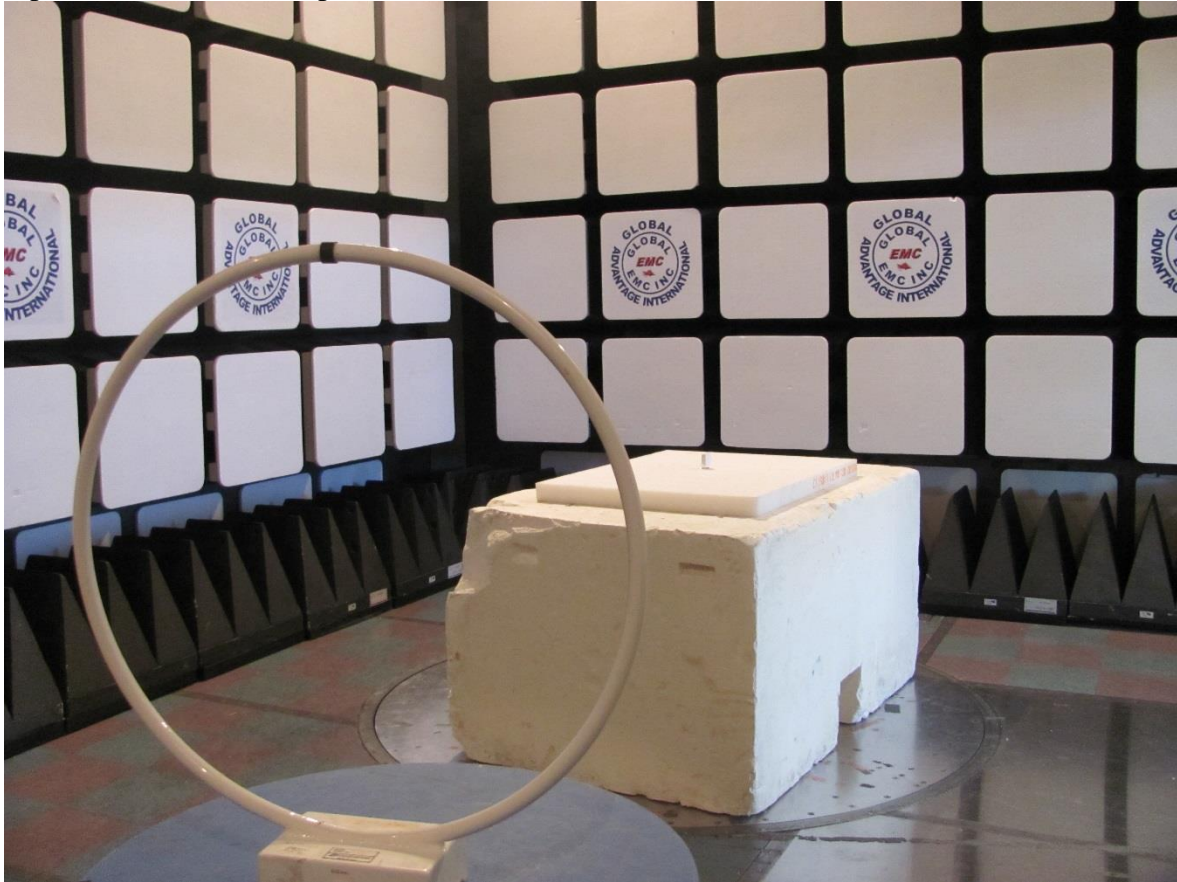

Illustration 1: Radiated emission setup – photo 1

Client	Ecobee Inc	
Product	Athena RS Gen 2	
Standard(s)	RSS 247: 2015 / FCC Part 15 Subpart C 15:2016	



Illustration 2: Radiated emission setup - photo 2

Client	Ecobee Inc	
Product	Athena RS Gen 2	
Standard(s)	RSS 247: 2015 / FCC Part 15 Subpart C 15:2016	

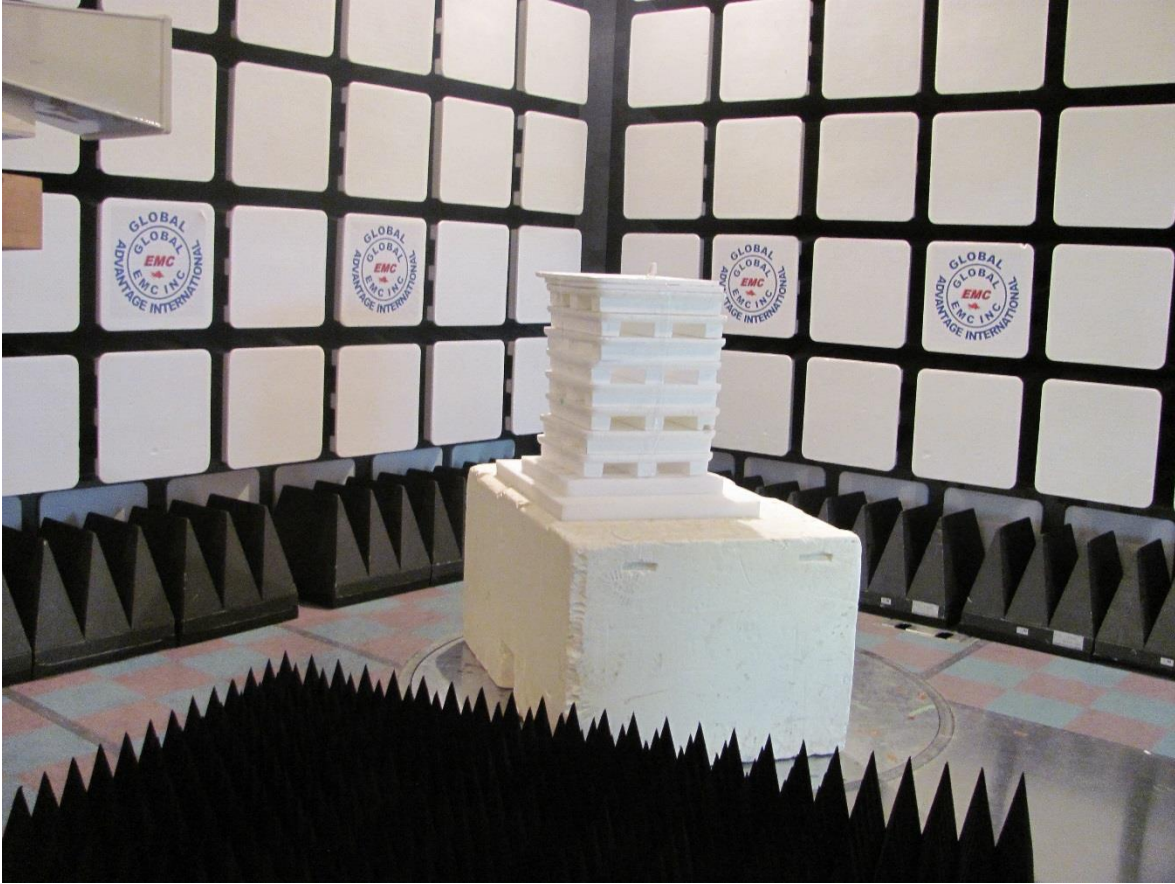

Illustration 3: Radiated setup - photo 3

Client	Ecobee Inc	
Product	Athena RS Gen 2	
Standard(s)	RSS 247: 2015 / FCC Part 15 Subpart C 15:2016	



Illustration 4: Antenna conducted setup - photo