



Canada

EMC & RF Test Report

As per

RSS-247 Issue 2:2017 & FCC Part 15 Subpart 15.247:2015

Unlicensed Intentional Radiators

on the

ECB401

Issued by:

TÜV SÜD Canada Inc.
11 Gordon Collins Dr,
Gormley, ON, L0H 1G0
Canada
Ph: (905) 883-7255

Testing produced for



See Appendix A for full client & EUT details.

Min Xie,
Senior EMC Project
Engineer



Registration #
6844A-3



Testing Laboratory
Certificate #2955.02



R-4023, G-506
C-4498, T-1246



Registration #
CA6844



| | | |
|-------------|---|---|
| Client | Ecobee Inc. |  |
| Product | ECB401 | |
| Standard(s) | RSS 247 Issue 2:2017 FCC Part 15 Subpart 15.247:2015 | |

Table of Contents

| | |
|---|----|
| Table of Contents | 2 |
| Report Scope | 3 |
| Summary | 4 |
| Test Results Summary | 5 |
| Notes, Justifications, or Deviations | 6 |
| Sample Calculation(s) | 6 |
| Applicable Standards, Specifications and Methods | 7 |
| Document Revision Status | 8 |
| Definitions and Acronyms | 9 |
| Testing Facility | 10 |
| Calibrations and Accreditations | 10 |
| Testing Environmental Conditions and Dates | 11 |
| Detailed Test Results Section | 12 |
| Channel Carrier Bandwidth | 13 |
| Carrier Frequency Separation | 16 |
| Number of Hopping Frequencies | 19 |
| Time of Occupancy | 22 |
| Maximum Peak Envelope Conducted Power - FHSS | 26 |
| Antenna Spurious Conducted Emissions (-20 dBc Requirement) – 15.247 | 29 |
| Radiated Emissions – 15.247 | 32 |
| Power Line Conducted Emissions | 44 |
| Appendix A – EUT Summary | 49 |

| | | |
|-------------|---|---|
| Client | Ecobee Inc. |  |
| Product | ECB401 | |
| Standard(s) | RSS 247 Issue 2:2017 FCC Part 15 Subpart 15.247:2015 | |

Report Scope

This report addresses the EMC verification testing and test results of the **Ecobee Inc.'s ECB401**, and is herein referred to as EUT (Equipment Under Test). The EUT was tested for compliance against the following standards:

RSS-247 Issue 2:2015

FCC Part 15 Subpart C 15.247:2015

Test procedures, results, justifications, and engineering considerations, if any, follow later in this report.

The results contained in this report relate only to the item(s) tested.

This report does not imply product endorsement by any government, accreditation agency, or TÜV SÜD Canada Inc.

Opinions or interpretations expressed in this report, if any, are outside the scope of TÜV SÜD Canada Inc. accreditations. Any opinions expressed do not necessarily reflect the opinions of TÜV SÜD Canada Inc., unless otherwise stated.

| | | |
|-------------|---|---|
| Client | Ecobee Inc. |  |
| Product | ECB401 | |
| Standard(s) | RSS 247 Issue 2:2017 FCC Part 15 Subpart 15.247:2015 | |

Summary

The results contained in this report relate only to the item(s) tested.

| | |
|--------------------------------------|-------------------|
| EUT: | ECB401 |
| FCC Certification #, FCC ID: | WR9116151212151 |
| Industry Canada Certification #, IC: | 7981A-11615121215 |
| EUT passed all tests performed | Yes |
| Tests conducted by | Min Xie |

For testing dates, see "Testing Environmental Conditions and Dates".

| | | |
|-------------|---|---|
| Client | Ecobee Inc. |  |
| Product | ECB401 | |
| Standard(s) | RSS 247 Issue 2:2017 FCC Part 15 Subpart 15.247:2015 | |

Test Results Summary

| Standard/Method | Description | Class/Limit | Result |
|--|--|-------------------------------|--|
| FCC 15.203 | Antenna Requirement | Unique | Pass See Justification |
| FCC 15.205 RSS GEN Table 6 | Restricted Bands for intentional operation | None within band | Pass See description |
| FCC 15.207 RSS GEN Table 3 | Power line conducted emissions | QuasiPeak Average | N/A See Justification |
| FCC 15.209 RSS GEN Table 4 | Radiated emissions | QuasiPeak Average | Pass |
| FCC 15.247(a)(1) RSS 247 5.1 (2) | Channel Separation | > 25 kHz or 20 dB BW | Pass |
| FCC 15.247(a)(1)(i) RSS 247 5.1 (3) | Number of channels | > 50 | Pass |
| FCC 15.247(a)(1)(i) RSS 247 5.1 (3) | Time of occupancy | < 0.4 sec in 20 sec period | Pass |
| FCC 15.247(b) RSS 247 5.4(1) | Max output power | < 1 Watt | Pass |
| FCC 15.247(b)(4) RSS 247 5.4 (3) | Antenna Gain | < 6 dBi | Pass See Justification |
| FCC 15.247(d) RSS 247 5.5 | Antenna conducted spurious | > 20 dBc | Pass |
| FCC 15.247(h) RSS GEN 247 5.1 | FHSS Intelligence | No coordination | Pass See Justification |
| FCC 15.247(i) RSS-102 | Maximum Permissible Exposure | > 20 cm separation. | Pass See justification and calculations |
| Overall Result | | | PASS |

If the product as tested or otherwise complies with the specification, the EUT is deemed to comply with the requirement and is deemed a 'PASS' grade. If not 'FAIL' grade will be issued. Note that 'PASS' / 'FAIL' grade is independent of any measurement uncertainties. A 'PASS' / 'FAIL' grade within measurement uncertainty is marked with a '*'.

| | | |
|-------------|---|---|
| Client | Ecobee Inc. |  |
| Product | ECB401 | |
| Standard(s) | RSS 247 Issue 2:2017 FCC Part 15 Subpart 15.247:2015 | |

Notes, Justifications, or Deviations

The following notes, justifications for tests not performed or deviations from the above listed specifications apply:

For the Antenna requirement specified in FCC 15.203 (RSS-247 section 5.5), the unit uses a 1.5 dBi PCB antenna which is less than 6 dBi gain.

For the Restricted Bands of operation, the EUT is designed to only operate between 902 – 928 MHz.

The EUT is not a hybrid system and FCC 15.247 (f) does not apply to it.

For maximum permissible exposure is designed to operate greater than 20 cm from any personnel during normal operation. No testing is required, however worst case calculated exposure compliance follows later in this report.

The EUT does not coordination transmission with any other FHSS to avoid simultaneous occupation of hopping frequencies.

The EUT contains a 902 – 928 MHz FHSS transmitter and a 2400 – 2483.5 MHz DTS transmitter. The Firmware guarantees simultaneous will not occur. Antenna co-location testing is therefore not applicable.

For maximum permissible exposure, this device operates at less than 1 Watt at 902 - 928 MHz and is designed to operate greater than 20 cm from any personnel during normal operation. No testing is required, however worst case calculated exposure compliance was shown in the RF Exposure exhibits.

Sample Calculation(s)

Radiated Emission Test

Margin = Limit – (Received Signal + Antenna Factor + Cable Loss – Pre-Amp Gain)

Margin = 50.5dB μ V/m – (50dB μ V + 10dB + 2.5dB – 20dB)

Margin = 8.0 dB (pass)

Power Line Conducted Emission Test

Margin = Limit – (Received Signal + Attenuation Factor + Cable Loss + LISN Factor)

Margin = 73.0dB μ V – (50dB μ V + 10dB + 2.5dB + 0.5dB)

Margin = 10.0 dB (pass)

| | | |
|-------------|---|---|
| Client | Ecobee Inc. |  |
| Product | ECB401 | |
| Standard(s) | RSS 247 Issue 2:2017 FCC Part 15 Subpart 15.247:2015 | |

Applicable Standards, Specifications and Methods

| | |
|------------------------------|---|
| ANSI C63.4:2014 | Methods of Measurement of Radio-Noise Emissions from Low-Voltage Electrical and Electronic Equipment in the Range of 9 kHz to 40 GHz |
| ANSI C63.10:2013 | American National Standard For Testing Unlicensed Wireless Devices |
| CFR 47 FCC 15 Subpart C:2015 | Code of Federal Regulations – Radio Frequency Devices, Intentional Radiators |
| CISPR 22:2008 | Information Technology Equipment - Radio Disturbance Characteristics - Limits and Methods of Measurement |
| ICES-003 Issue 6 2016 | Digital Apparatus - Spectrum Management and Telecommunications Policy Interference-Causing Equipment Standard |
| RSS-GEN Issue 4 2014 | General Requirements and Information for the Certification of Radio Apparatus |
| RSS-247 Issue 2:2017 | Issue 2: Digital Transmission Systems (DTSs), Frequency Hopping Systems (FHSs) and Licence-Exempt Local Area Network (LE-LAN) Devices |
| RSS 102 Issue 5 2015 | Radio Frequency (RF) Exposure Compliance of Radiocommunication Apparatus (All Frequency Bands) |
| FCC KDB 447498 v06 | RF Exposure Procedures And Equipment Authorization Policies For Mobile And Portable Devices |
| ISO 17025:2005 | General Requirements for the Competence of Testing and Calibration Laboratories |

| | | |
|-------------|---|---|
| Client | Ecobee Inc. |  Canada |
| Product | ECB401 | |
| Standard(s) | RSS 247 Issue 2:2017 FCC Part 15 Subpart 15.247:2015 | |

Document Revision Status

Revision 1 - Mar 23, 2017
Initial Release

| | | |
|-------------|---|---|
| Client | Ecobee Inc. |  |
| Product | ECB401 | |
| Standard(s) | RSS 247 Issue 2:2017 FCC Part 15 Subpart 15.247:2015 | |

Definitions and Acronyms

The following definitions and acronyms are applicable in this report.
See also ANSI C63.14.

AE – Auxiliary Equipment. A digital accessory that feeds data into or receives data from another device (host) that in turn, controls its operation.

BW – Bandwidth. Unless otherwise stated, this refers to the 6 dB bandwidth.

EMC – Electro-Magnetic Compatibility. The ability of an equipment or system to function satisfactorily in its electromagnetic environment without introducing intolerable electromagnetic disturbances to anything in that environment.

EMI – Electro-Magnetic Immunity. The ability to maintain a specified performance when the equipment is subjected to disturbance (unwanted) signals of specified levels.

EUT – Equipment Under Test. A device or system being evaluated for compliance that is representative of a product to be marketed.

ITE – Information Technology Equipment with a primary function(s) of entry, storage, display, retrieval, transmission, processing, switching, or control, of data.

LISN – Line Impedance Stabilization Network

NCR – No Calibration Required

RF – Radio Frequency

| | | |
|-------------|---|---|
| Client | Ecobee Inc. |  |
| Product | ECB401 | |
| Standard(s) | RSS 247 Issue 2:2017 FCC Part 15 Subpart 15.247:2015 | |

Testing Facility

Testing for EMC on the EUT was carried out at TÜV SÜD Canada labs near Toronto, Ontario. The testing lab consists of a 3m semi-anechoic chamber calibrated to be able to allow measurements on an EUT that has a maximum width or length of up to 2m and a height of up to 3m. The chamber is equipped with a turntable that is capable of testing devices up to 3300lb in weight. This facility is capable of testing products that are rated for 120Vac and 240Vac single phase, or devices that are rated for a 208Vac 3 phase input. DC capability is also available for testing. The chamber is equipped with a mast that controls the polarization and height of the antenna. Control of the mast occurs in the control room adjoining the shielded chamber. Radiated emission measurements are performed using a BiLog antenna and a Horn antenna where applicable. Conducted emissions, unless otherwise stated, are performed using a LISN and using the Vertical Ground plane if applicable.

Calibrations and Accreditations

The 3m semi-anechoic chamber is registered with Federal Communications Commission (FCC, CA6844), Industry Canada (IC, 6844A-3) and Voluntary Control Council for Interference (VCCI, R-4023, G-506, C-4498, and T-1246). This chamber was calibrated for Normalized Site Attenuation (NSA) using test procedures outlined in ANSI C63.4 "Methods of Measurement of Radio-Noise Emissions from Low-Voltage Electrical and Electronic Equipment in the Range of 9 kHz to 40 GHz". The chamber is lined with ferrite tiles and absorption cones to minimize any undesired reflections. The NSA data is kept on file at TÜV SÜD Canada. For radiated susceptibility testing, a 16 point field calibration has been performed on the chamber. The field uniformity data is kept on file at TÜV SÜD Canada. TÜV SÜD Canada Inc is accredited to ISO 17025 by A2LA with Testing Certificate #2555.01. The laboratory's current scope of accreditation listing can be found as listed on the A2LA website. All measuring equipment is calibrated on an annual or bi-annual basis as listed for each respective test.

| | | |
|-------------|---|---|
| Client | Ecobee Inc. |  |
| Product | ECB401 | |
| Standard(s) | RSS 247 Issue 2:2017 FCC Part 15 Subpart 15.247:2015 | |

Testing Environmental Conditions and Dates

Following environmental conditions were recorded in the facility during time of testing

| Date | Test | Initials | Temperature (°C) | Humidity (%) | Pressure (kPa) |
|--------------|--------------------------------|-----------------|-------------------------|---------------------|-----------------------|
| 2017/2/14,15 | Radiated Emissions | MX | 20 – 24 | 40 – 51 | 98.0 – 102.0 |
| 2017/2/27 | Antenna Conducted Emissions | MX | 20 – 24 | 40 – 51 | 98.0 – 102.0 |
| 2017/3/2 | Power Line Conducted Emissions | MX | 20 – 24 | 40 – 51 | 98.0 – 102.0 |

| | | |
|-------------|---|---|
| Client | Ecobee Inc. |  Canada |
| Product | ECB401 | |
| Standard(s) | RSS 247 Issue 2:2017 FCC Part 15 Subpart 15.247:2015 | |

Detailed Test Results Section

| | | |
|-------------|---|---|
| Client | Ecobee Inc. |  |
| Product | ECB401 | |
| Standard(s) | RSS 247 Issue 2:2017 FCC Part 15 Subpart 15.247:2015 | |

Channel Carrier Bandwidth

Purpose

The purpose of this test is to allow for results that is used to help establish other limits. Although there is not specific limit for this requirement, the derived limits dependant on this information helps allow for other spread spectrum devices to co-exist in the same frequency spectrum.. This also helps prevent corruption of data by ensuring adequate channel separation to distinguish the reception of the intended information.

Limits and Methods

The limits are as defined in 47 CFR FCC Part 15 Section 15.247(a)(1). The test method is a defined in ANSI C63.10.

The maximum allowed 20 dB bandwidth for frequency hopping system operating in the 902 to 928 MHz band is 500 kHz.

Results

The EUT passed. The maximum 20 dB BW measured was 91.67 kHz.

| Channel | Frequency (MHz) | 20 dB Bandwidth (kHz) | Limit (kHz) | Pass/Fail |
|---------|-----------------|-----------------------|-------------|-----------|
| 0 | 902.8 | 91.67 | <500 | Pass |
| 35 | 915.1 | 91.67 | <500 | Pass |
| 71 | 927.7 | 91.03 | <500 | Pass |

| | | |
|-------------|---|---|
| Client | Ecobee Inc. |  |
| Product | ECB401 | |
| Standard(s) | RSS 247 Issue 2:2017 FCC Part 15 Subpart 15.247:2015 | |

Graph(s)

The graphs shown below shows the 20 dB bandwidth during the operation of the device. This is measured by a max hold on the spectrum analyzer and the highest resolution bandwidth that is sufficiently low to exhibit the 20 dB bandwidth of a channel during operation of the EUT. This measurement is a peak measurement. Max hold is performed for a duration of not less than 1 minute.

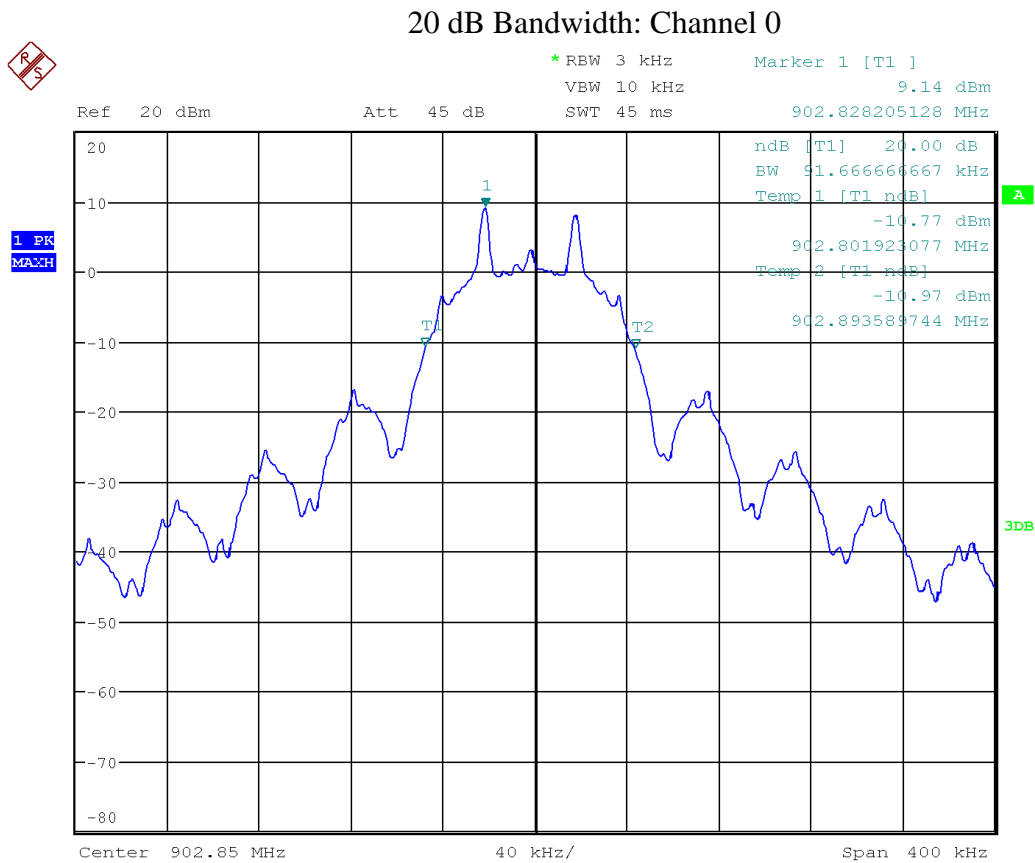

Date: 27.FEB.2016 14:28:35

Note: See ‘Appendix B – EUT & Test Setup Photographs’ for photos showing the test set-up.

| | | |
|-------------|---|---|
| Client | Ecobee Inc. |  |
| Product | ECB401 | |
| Standard(s) | RSS 247 Issue 2:2017 FCC Part 15 Subpart 15.247:2015 | |

Test Equipment List

| Equipment | Model No. | Manufacturer | Last calibration / Verification date | Next calibration/ Verification due date | Asset # |
|---------------------------|-------------|------------------------|--------------------------------------|---|----------|
| 26.5GHz Spectrum Analyzer | FSU26 | Rohde & Schwarz | Feb-15, 2017 | Feb-15, 2019 | GEMC 232 |
| 10 dB attenuator | 605-10-1F18 | Meca Electronics, Inc. | Feb-15, 2017 | Feb-15, 2018 | GEMC225 |

This report module is based on GEMC template "FCC – Power Line Conducted Emissions Class B_Rev1"

| | | |
|-------------|---|---|
| Client | Ecobee Inc. |  |
| Product | ECB401 | |
| Standard(s) | RSS 247 Issue 2:2017 FCC Part 15 Subpart 15.247:2015 | |

Carrier Frequency Separation

Purpose

The purpose of this test is to ensure that the RF energy of frequency hopping systems is sufficiently spread over a spectrum and that the radio energy is not overly dense. This limit helps allow for other spread spectrum devices to co-exist in the same frequency spectrum. This also helps prevent corruption of data by ensuring adequate channel separation to distinguish the reception of the intended information.

Limits and method

The limits are as defined in 47 CFR FCC Part 15 Section 15.247(a)(1). The test method is a defined in ANSI C63.10.

| | 902 to 928 MHz | 2400 to 2483.5 MHz | 5275 to 5850 MHz |
|---------------|---------------------------------|--|---------------------------------|
| No conditions | 25 kHz or 20 dB BW ¹ | 25 kHz or 20 dB BW ¹ | 25 kHz or 20 dB BW ¹ |
| < 125 mW | -- | 25 kHz or 2/3 of 20 dB BW ¹ | -- |

Note 1: The minimum channel separation is given by the greater of 25 kHz or 20 dB BW for unconditional operation. The 20 dB BW of the system was measured to be 91.67 kHz, so a channel separation limit of 91.67 kHz applies.

Results

The EUT passed the requirements of channel carrier spacing exceeding the measured 20 dB BW of the EUT. The 20 dB BW previously measured was 91.67 kHz, and the device had a minimum channel spacing of 346.15 kHz.

| | | |
|-------------|---|---|
| Client | Ecobee Inc. |  Canada |
| Product | ECB401 | |
| Standard(s) | RSS 247 Issue 2:2017 FCC Part 15 Subpart 15.247:2015 | |

Graph(s)

The graphs shown below shows the channel spacing during the operation of the device. This is measured by a max hold on the spectrum analyzer and the highest resolution bandwidth that is sufficiently low to exhibit the channel spacing of the signal being measured. This measurement is a peak measurement. Max hold is performed for a duration of not less than 1 minute, as the device is stepping through its hopping table.

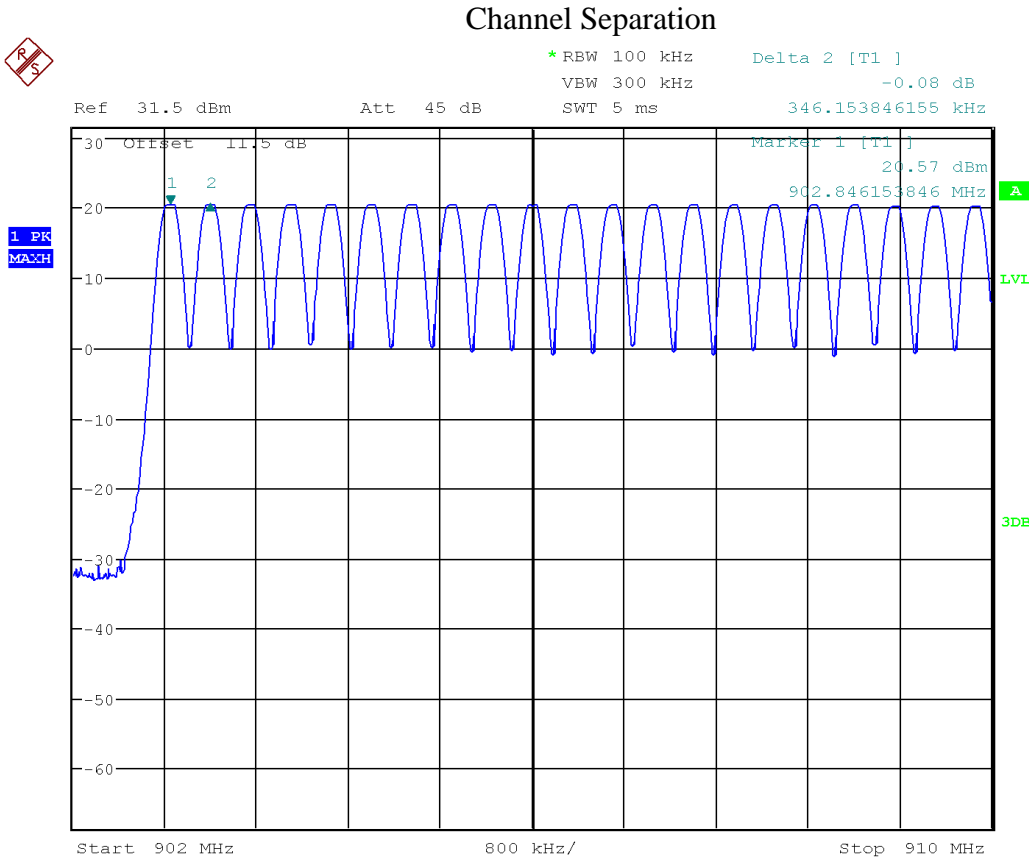

Date: 27.FEB.2016 16:38:04

Note: See 'Appendix B – EUT & Test Setup Photographs' for photos showing the test set-up.

© TÜV SÜD Canada Inc. This test report shall not be reproduced except in full, without written approval of TÜV SÜD Canada Inc

| | | |
|-------------|---|---|
| Client | Ecobee Inc. |  |
| Product | ECB401 | |
| Standard(s) | RSS 247 Issue 2:2017 FCC Part 15 Subpart 15.247:2015 | |

Test Equipment List

| Equipment | Model No. | Manufacturer | Last calibration / Verification date | Next calibration/ Verification due date | Asset # |
|---------------------------|-------------|------------------------|--------------------------------------|---|----------|
| 26.5GHz Spectrum Analyzer | FSU26 | Rohde & Schwarz | Feb-15, 2017 | Feb-15, 2019 | GEMC 232 |
| 10 dB attenuator | 605-10-1F18 | Meca Electronics, Inc. | Feb-15, 2017 | Feb-15, 2018 | GEMC225 |

This report module is based on GEMC template "FCC – Power Line Conducted Emissions Class B_Rev1"

| | | |
|-------------|---|---|
| Client | Ecobee Inc. |  |
| Product | ECB401 | |
| Standard(s) | RSS 247 Issue 2:2017 FCC Part 15 Subpart 15.247:2015 | |

Number of Hopping Frequencies

Purpose

The purpose of this test is to ensure that the RF energy of frequency hopping systems is sufficiently spread over a spectrum and that the radio energy is not overly dense. This limit helps allow for other spread spectrum devices to co-exist in the same frequency spectrum. This also helps prevent corruption of data by ensuring adequate channel separation to distinguish the reception of the intended information.

Limits and method

The limits are as defined in 47 CFR FCC Part 15 Section 15.247(a)(1). The test method is a defined in ANSI C63.10.

| | | | |
|--------------------------|----------------|--------------------|------------------|
| | 902 to 928 MHz | 2400 to 2483.5 MHz | 5275 to 5850 MHz |
| No conditions | ≥ 50 channels | ≥ 15 channels | ≥ 75 channels |
| 20 dB BW exceeds 250 kHz | ≥ 25 channels | ≥ 15 channels | ≥ 75 channels |

Results

The EUT passed the requirements of the number of channels. The number of channels the device occupies is 72 channels in the allocation band of 902 to 928 MHz.

| | | |
|-------------|---|---|
| Client | Ecobee Inc. |  Canada |
| Product | ECB401 | |
| Standard(s) | RSS 247 Issue 2:2017 FCC Part 15 Subpart 15.247:2015 | |

Graph(s)

The graphs shown below shows the number of occupied channels during the operation of the device. This is measured by a max hold on the spectrum analyzer and the highest resolution bandwidth that is sufficiently low to exhibit the channel spacing of the signal being measured. This measurement is a peak measurement. Max hold is performed for a duration of not less than 10 minutes, or as sufficient to capture the channels occupied.

Graph 1 of 2 (38 channels)

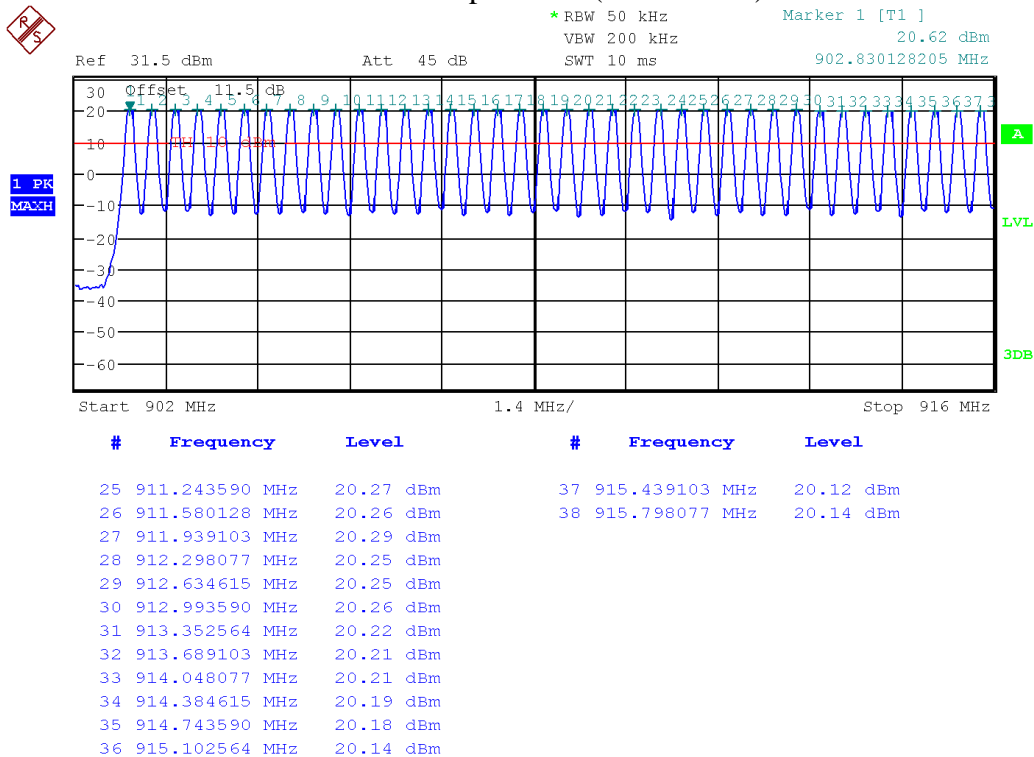

Date: 27.FEB.2016 16:53:59

| | | |
|-------------|---|---|
| Client | Ecobee Inc. |  |
| Product | ECB401 | |
| Standard(s) | RSS 247 Issue 2:2017 FCC Part 15 Subpart 15.247:2015 | |

Graph 2 of 2 (34 channels)

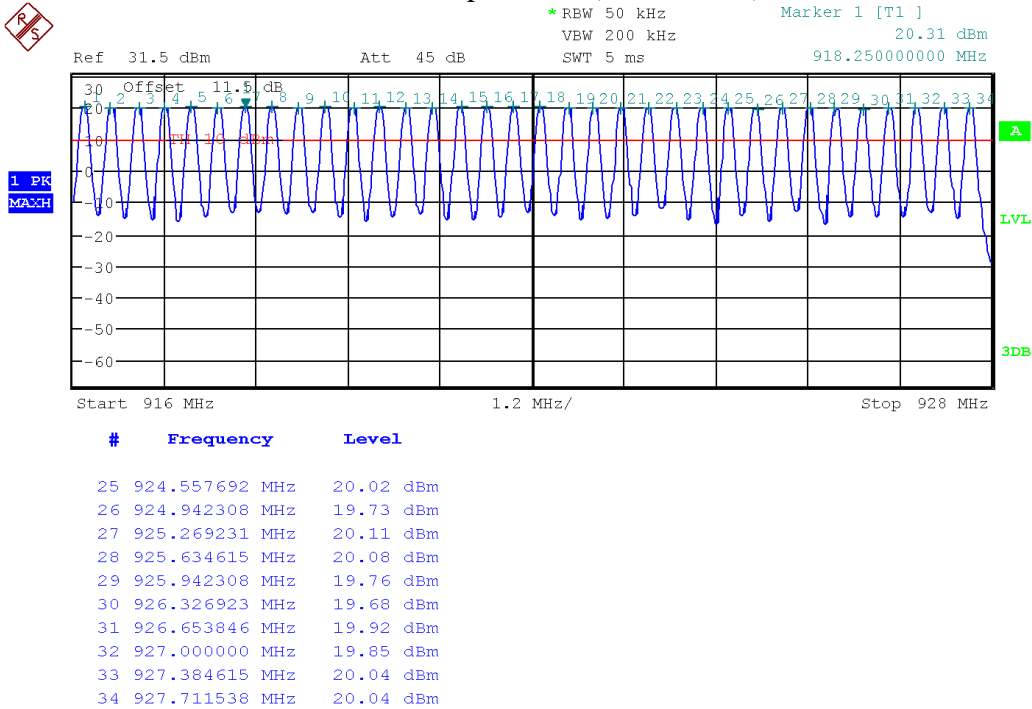

Date: 27.FEB.2016 16:57:06

Note: See ‘Appendix B – EUT & Test Setup Photographs’ for photos showing the test set-up.

Test Equipment List

| Equipment | Model No. | Manufacturer | Last calibration / Verification date | Next calibration/ Verification due date | Asset # |
|---------------------------|-------------|------------------------|--------------------------------------|---|----------|
| 26.5GHz Spectrum Analyzer | FSU26 | Rohde & Schwarz | Feb-15, 2017 | Feb-15, 2019 | GEMC 232 |
| 10 dB attenuator | 605-10-1F18 | Meca Electronics, Inc. | Feb-15, 2017 | Feb-15, 2018 | GEMC225 |

This report module is based on GEMC template “FCC – Power Line Conducted Emissions Class B_Rev1”

| | | |
|-------------|---|---|
| Client | Ecobee Inc. |  |
| Product | ECB401 | |
| Standard(s) | RSS 247 Issue 2:2017 FCC Part 15 Subpart 15.247:2015 | |

Time of Occupancy

Purpose

The purpose of this test is to ensure that the RF energy of frequency hopping systems is hopping at a minimum defined rate. This helps ensure sufficient time off to enable other frequency hopping devices to co-operate within this allocated band.

Limits

For 902 to 928 MHz systems, the limits are as defined in 47 CFR FCC Part 15 Section 15.247(a)(1)(i).

For frequency hopping systems operating in the 902-928 MHz band: if the 20 dB bandwidth of the hopping channel is less than 250 kHz, the system shall use at least 50 hopping frequencies and the average time of occupancy on any frequency shall not be greater than 0.4 seconds within a 20 second period; if the 20 dB bandwidth of the hopping channel is 250 kHz or greater, the system shall use at least 25 hopping frequencies and the average time of occupancy on any frequency shall not be greater than 0.4 seconds within a 10 second period. The maximum allowed 20 dB bandwidth of the hopping channel is 500 kHz.

The 20 dB bandwidth of the system is <250 kHz and have more than 50 channels; therefore the average time of occupancy on any frequency shall not be greater than 0.4 seconds within a 20 second period.

Results

The EUT passed the requirements. The maximum average time of occupancy is 0.2 seconds.

The EUT cycles through its pseudo-random generated list of hopping frequencies. There are 72 channels occupied in total. The average transmit time is 5.08 ms per channel and each channel is repeated every 711.54 ms.

The analyzer sweep time is 1000 ms.

There are 2 hops on the spectrum analyzer.

Number of hops in 20 s = (number of hops on spectrum analyzer) × (period specified in the requirements / analyzer sweep time)

Number of hops in 20 s = 2 × (20000/1000) = 40

| | | |
|-------------|---|---|
| Client | Ecobee Inc. |  |
| Product | ECB401 | |
| Standard(s) | RSS 247 Issue 2:2017 FCC Part 15 Subpart 15.247:2015 | |

Average time of occupancy = $40 \times 5.08 \text{ ms} = 203.2 \text{ ms}$

Graph(s)

Transmit time per hop

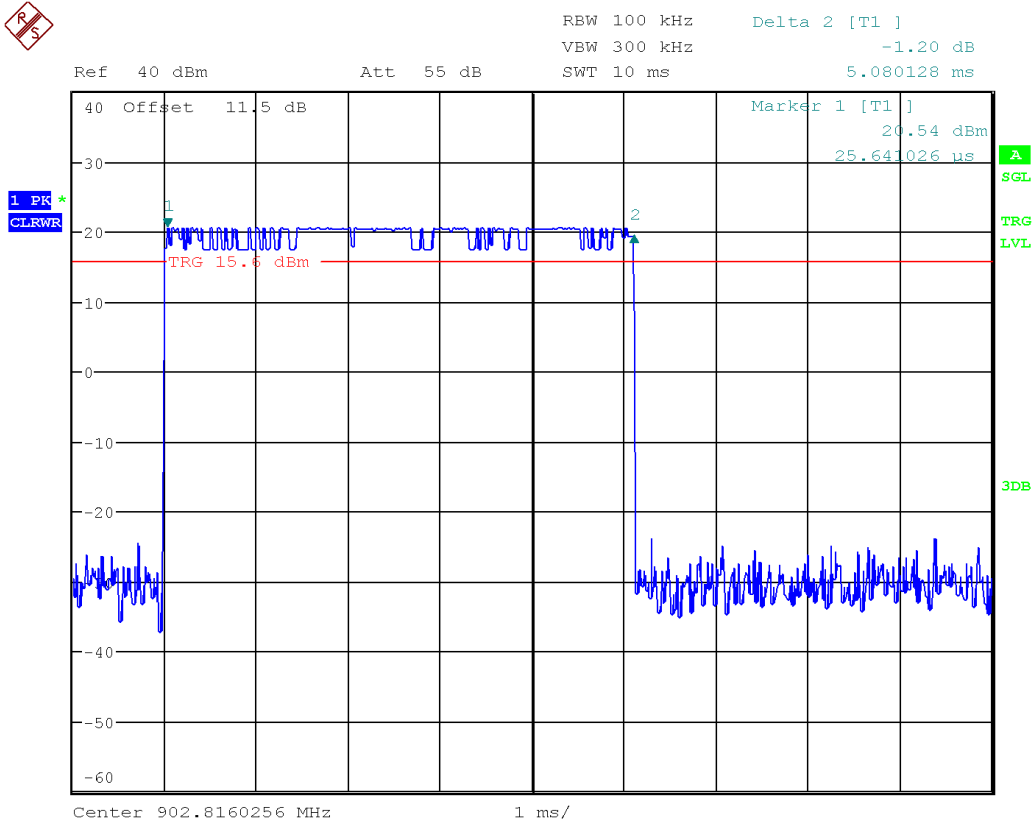

Date: 29.FEB.2016 10:32:58

| | | |
|-------------|---|---|
| Client | Ecobee Inc. |  |
| Product | ECB401 | |
| Standard(s) | RSS 247 Issue 2:2017 FCC Part 15 Subpart 15.247:2015 | |

Repetition Rate

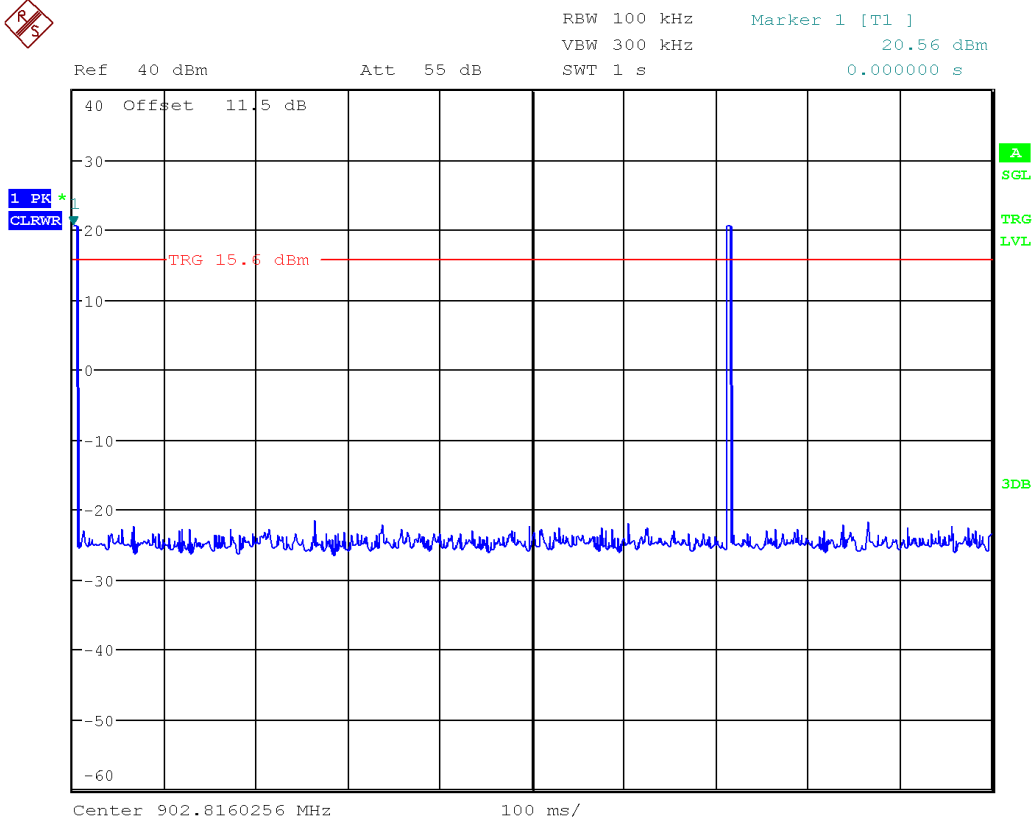

Date: 29.FEB.2016 10:36:19

Note: See 'Appendix B – EUT & Test Setup Photographs' for photos showing the test set-up.

© TÜV SÜD Canada Inc. This test report shall not be reproduced except in full, without written approval of TÜV SÜD Canada Inc

| | | |
|-------------|---|---|
| Client | Ecobee Inc. |  Canada |
| Product | ECB401 | |
| Standard(s) | RSS 247 Issue 2:2017 FCC Part 15 Subpart 15.247:2015 | |

Test Equipment List

| Equipment | Model No. | Manufacturer | Last calibration / Verification date | Next calibration/ Verification due date | Asset # |
|---------------------------|-------------|------------------------|--------------------------------------|---|----------|
| 26.5GHz Spectrum Analyzer | FSU26 | Rohde & Schwarz | Feb-15, 2017 | Feb-15, 2019 | GEMC 232 |
| 10 dB attenuator | 605-10-1F18 | Meca Electronics, Inc. | Feb-15, 2017 | Feb-15, 2018 | GEMC225 |

This report module is based on GEMC template "FCC – Power Line Conducted Emissions Class B_Rev1"

| | | |
|-------------|---|---|
| Client | Ecobee Inc. |  |
| Product | ECB401 | |
| Standard(s) | RSS 247 Issue 2:2017 FCC Part 15 Subpart 15.247:2015 | |

Maximum Peak Envelope Conducted Power - FHSS

Purpose

The purpose of this test is to ensure that the maximum power conducted to the radiating element does not exceed the limits specified.

Limits and methods

The limits are defined in 15.247(b).

For frequency hopping systems operating in the 902-928 MHz band: 1 watt for systems employing at least 50 hopping channels; and, 0.25 watts for systems employing less than 50 hopping channels, but at least 25 hopping channels, as permitted under paragraph (a)(1)(i) of this section.

The test method is a defined in ANSI C63.10.

Results

The EUT passed. The peak power measured was 20.69 dBm (117.22 mW).

| Channel | Frequency (MHz) | Power (dBm) | Power (mW) | Limit (mW) | Pass/Fail |
|---------|-----------------|-------------|------------|------------|-----------|
| 0 | 902.8 | 20.69 | 117.22 | 1000 | Pass |
| 35 | 915.1 | 20.24 | 105.68 | 1000 | Pass |
| 71 | 927.7 | 19.71 | 93.54 | 1000 | Pass |

| | | |
|-------------|---|---|
| Client | Ecobee Inc. |  |
| Product | ECB401 | |
| Standard(s) | RSS 247 Issue 2:2017 FCC Part 15 Subpart 15.247:2015 | |

Measurement(s)

The graphs shown below shows the peak power output of the device during the antenna conducted measurement during transmit operation of the EUT.

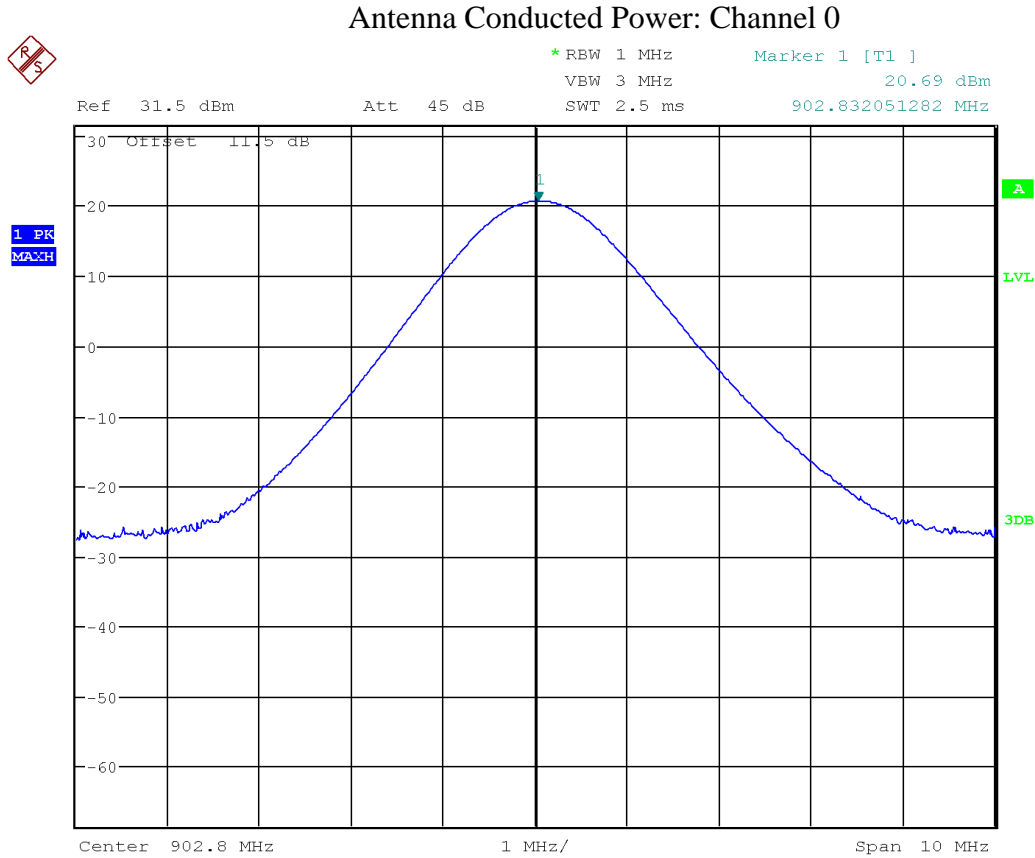

Date: 27.FEB.2016 18:01:12

Note: See 'Appendix B – EUT & Test Setup Photographs' for photos showing the test set-up.

| | | |
|-------------|---|---|
| Client | Ecobee Inc. |  Canada |
| Product | ECB401 | |
| Standard(s) | RSS 247 Issue 2:2017 FCC Part 15 Subpart 15.247:2015 | |

Test Equipment List

| Equipment | Model No. | Manufacturer | Last calibration / Verification date | Next calibration/ Verification due date | Asset # |
|---------------------------|-------------|------------------------|--------------------------------------|---|----------|
| 26.5GHz Spectrum Analyzer | FSU26 | Rohde & Schwarz | Feb-15, 2017 | Feb-15, 2019 | GEMC 232 |
| 10 dB attenuator | 605-10-1F18 | Meca Electronics, Inc. | Feb-15, 2017 | Feb-15, 2018 | GEMC225 |

This report module is based on GEMC template "FCC – Power Line Conducted Emissions Class B_Rev1"

| | | |
|-------------|---|---|
| Client | Ecobee Inc. |  |
| Product | ECB401 | |
| Standard(s) | RSS 247 Issue 2:2017 FCC Part 15 Subpart 15.247:2015 | |

Antenna Spurious Conducted Emissions (-20 dBc Requirement) – 15.247

Purpose

The purpose of this test is to ensure that the maximum power conducted to the radiating element at frequencies outside of the authorized spectrum does not exceed the limits specified. This ensures that the only the intended signal is delivered to the radiating element.

Limits and Methods

The limits are defined in 15.247(d). In any 100 kHz band, the peak spurious harmonics emissions must be at least 20 dB below the fundamental. Spurious Conducted emissions are to be evaluated up to the 10th harmonic. This -20 dBc requirement also applies at the ‘band edge’. Band edge testing shall be performed with the EUT in hopping and in single channel modes.

The method is given in and ANSI C63.10

Results

The EUT passed the limits. Low, middle and high channels were measured. The worst case was presented as a graph for the spectrum. The -20 dBc requirement is shown for the lower band edge at 902 MHz in the low band. The -20 dBc requirement is also shown for the higher band edge at 928 MHz in the high band.

| | | |
|-------------|---|---|
| Client | Ecobee Inc. |  |
| Product | ECB401 | |
| Standard(s) | RSS 247 Issue 2:2017 FCC Part 15 Subpart 15.247:2015 | |

Graph(s)

The graphs shown below shows the peak power output of the device during the antenna conducted measurement during transmit operation of the EUT.

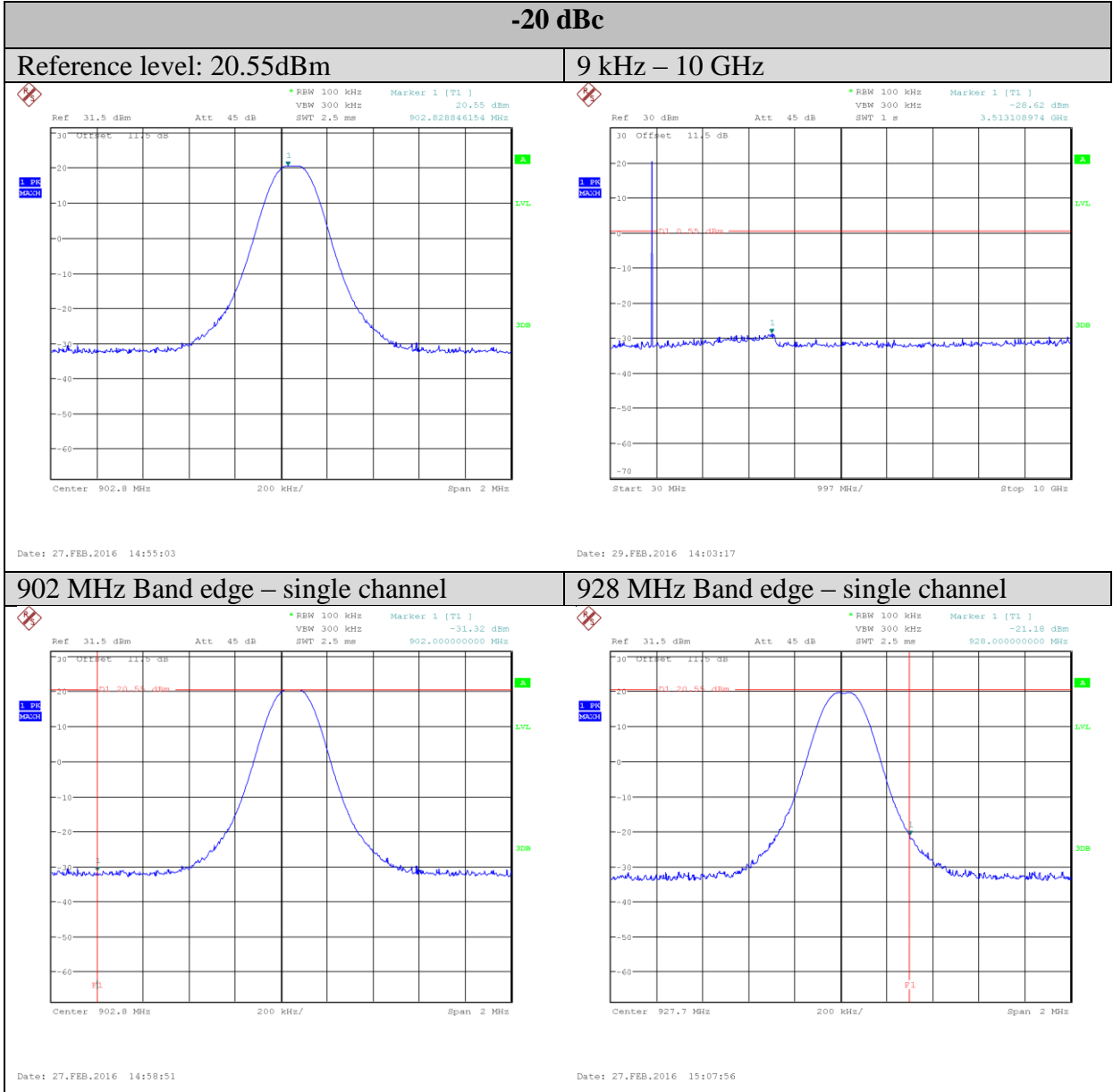

| | | |
|-------------|---|---|
| Client | Ecobee Inc. |  |
| Product | ECB401 | |
| Standard(s) | RSS 247 Issue 2:2017 FCC Part 15 Subpart 15.247:2015 | |

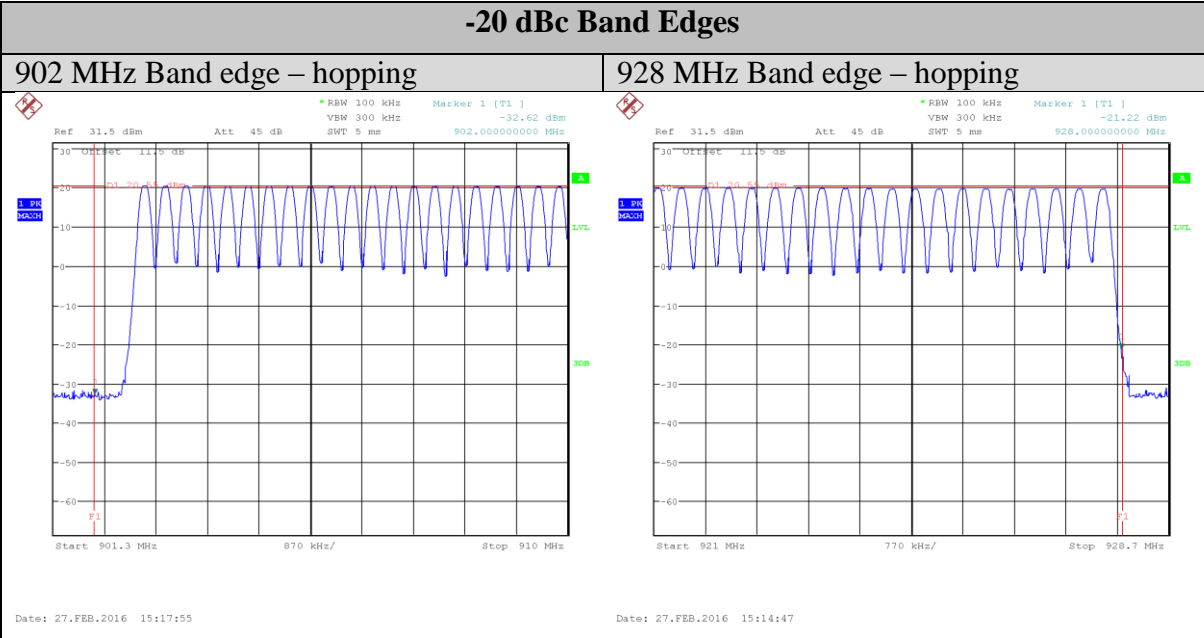

Note: See ‘Appendix B – EUT & Test Setup Photographs’ for photos showing the test set-up.

Test Equipment List

| Equipment | Model No. | Manufacturer | Last calibration / Verification date | Next calibration/ Verification due date | Asset # |
|---------------------------|-------------|------------------------|--------------------------------------|---|----------|
| 26.5GHz Spectrum Analyzer | FSU26 | Rohde & Schwarz | Feb-15, 2017 | Feb-15, 2019 | GEMC 232 |
| 10 dB attenuator | 605-10-1F18 | Meca Electronics, Inc. | Feb-15, 2017 | Feb-15, 2018 | GEMC225 |

This report module is based on GEMC template “FCC – Power Line Conducted Emissions Class B_Rev1”

| | | |
|-------------|---|---|
| Client | Ecobee Inc. |  |
| Product | ECB401 | |
| Standard(s) | RSS 247 Issue 2:2017 FCC Part 15 Subpart 15.247:2015 | |

Radiated Emissions – 15.247

Purpose

The purpose of this test is to ensure that the RF energy unintentionally emitted from the EUT does not exceed the limits listed below as defined in the applicable test standard, as measured from a receiving antenna. This helps protect broadcast radio services such as television, FM radio, pagers, cellular telephones, emergency services, and so on, from unwanted interference.

Limit and Method

The method is given in Section 12.1 of FCC KDB 558074 and ANSI C 63.10
The limits are as defined in FCC Part 15, Section 15.209:

The limits, as defined in 15.247(d) for unintentional radiated emissions apply for those emissions that fall in the restricted bands, as defined in Section 15.205(a). These emissions must comply with the radiated emission limits specified in Section 15.209(a).

All unintentional emissions must also meet the ‘Spurious Conducted Emissions’ requirements of -20 dBc or greater. See also ‘Spurious Conducted Emissions’ for further details.

0.009 MHz – 0.490 MHz, 2400/F (kHz) uV/m at 300 m¹
0.490 MHz – 1.705 MHz, 24000/F (kHz) uV/m at 30 m¹
1.705 MHz – 30 MHz, 30 uV/m at 30 m¹
30 MHz – 88 MHz, 100 uV/m (40.0 dBuV/m¹) at 3 m
88 MHz – 216 MHz, 150 uV/m (43.5 dBuV/m¹) at 3 m
216 MHz – 960 MHz, 200 uV/m (46.0 dBuV/m¹) at 3 m
Above 960 MHz, 500 uV/m (54.0 dBuV/m¹) at 3 m
Above 1000 MHz, 500 uV/m (54 dBuV/m²) at 3m
Above 1000 MHz, 500 uV/m (74 dBuV/m³) at 3m

¹Limit is with Quasi Peak detector with bandwidths as defined in CISPR-16-1-1

²Limit is with 1 MHz measurement bandwidth and using an Average detector

³Limit is with 1 MHz measurement bandwidth and using a Peak detector

| | | |
|-------------|---|---|
| Client | Ecobee Inc. |  |
| Product | ECB401 | |
| Standard(s) | RSS 247 Issue 2:2017 FCC Part 15 Subpart 15.247:2015 | |

Typical Radiated Emissions Setup

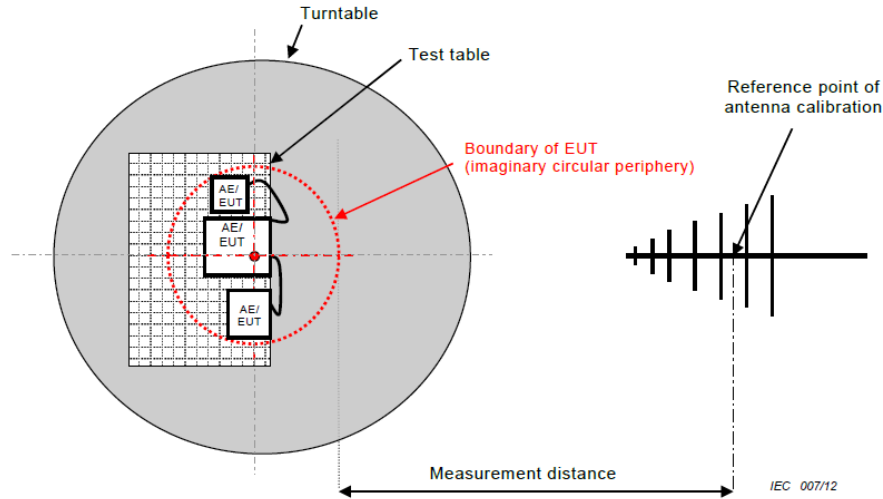

Measurement Uncertainty

The expanded measurement uncertainty is calculated in accordance with CISPR 16-4-2 and is +/-4.4 dB with a 'k=2' coverage factor and a 95% confidence level.

Preliminary Graphs

Note the graphs shown below are for graphical illustration only. For final measurements with the appropriate detector, please refer to the final measurement table where applicable. The graph shown below is a maximized peak measurement graph, measured with a resolution bandwidth greater than the final required detector and over a full 0-360 rotation. This peaking process is done as a worst case measurement. This process enables the detection of frequencies of concern for final measurement, and provides considerable time savings.

In accordance with FCC Part 15, Subpart A, Section 15.33, the device was scanned to the 10th harmonic.

Devices scanned may be scanned at alternate test distances, and in accordance with FCC Part 15, Subpart A, Section 15.31, an extrapolation factor of 20 dB/decade was used above 30 MHz and 40 dB/decade below 30 MHz. For example for 1 meter measurements, an extrapolation factor 9.5 dB from 20 Log (1m / 3m) is applied.

Low, middle and high channels were measured, each in three orthogonal axes were checked; however the worst case graphs are presented.

| | | |
|-------------|---|---|
| Client | Ecobee Inc. |  |
| Product | ECB401 | |
| Standard(s) | RSS 247 Issue 2:2017 FCC Part 15 Subpart 15.247:2015 | |

Band edge measure graphs were shown for illustrations purpose. See final measurement section for all measurements.

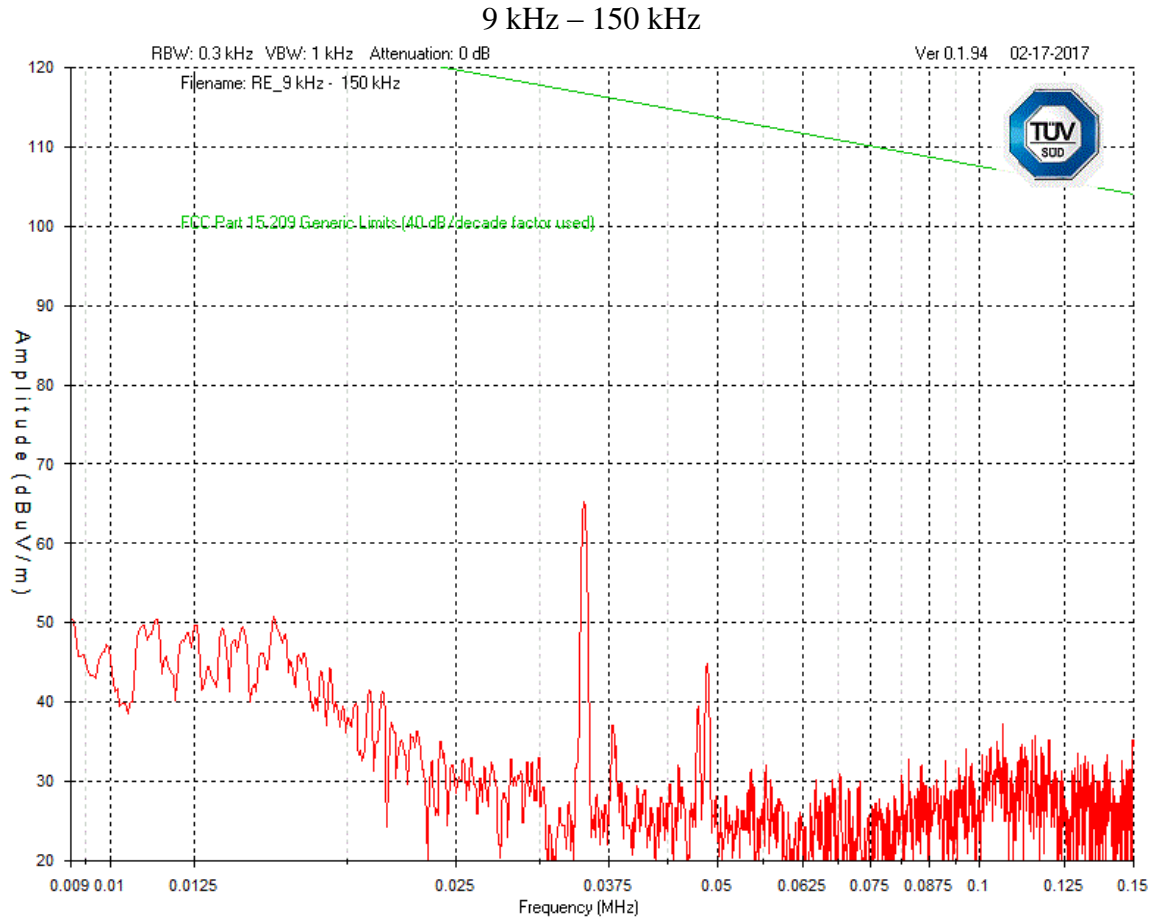

| | | |
|-------------|---|---|
| Client | Ecobee Inc. |  |
| Product | ECB401 | |
| Standard(s) | RSS 247 Issue 2:2017 FCC Part 15 Subpart 15.247:2015 | |

150 kHz – 30 MHz

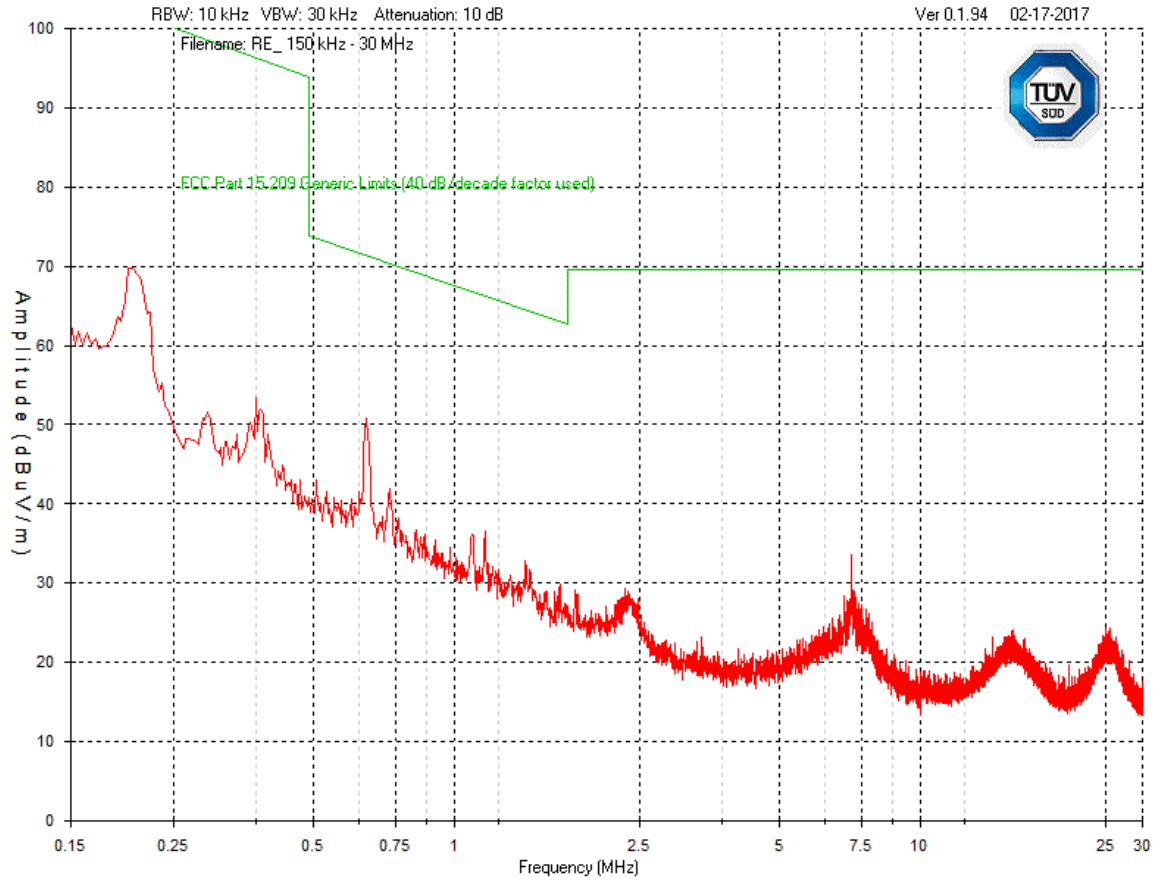

| | | |
|-------------|---|---|
| Client | Ecobee Inc. |  |
| Product | ECB401 | |
| Standard(s) | RSS 247 Issue 2:2017 FCC Part 15 Subpart 15.247:2015 | |

**Mid Channel - 30 MHz – 1 GHz
Vertical – Peak Emission Graph**

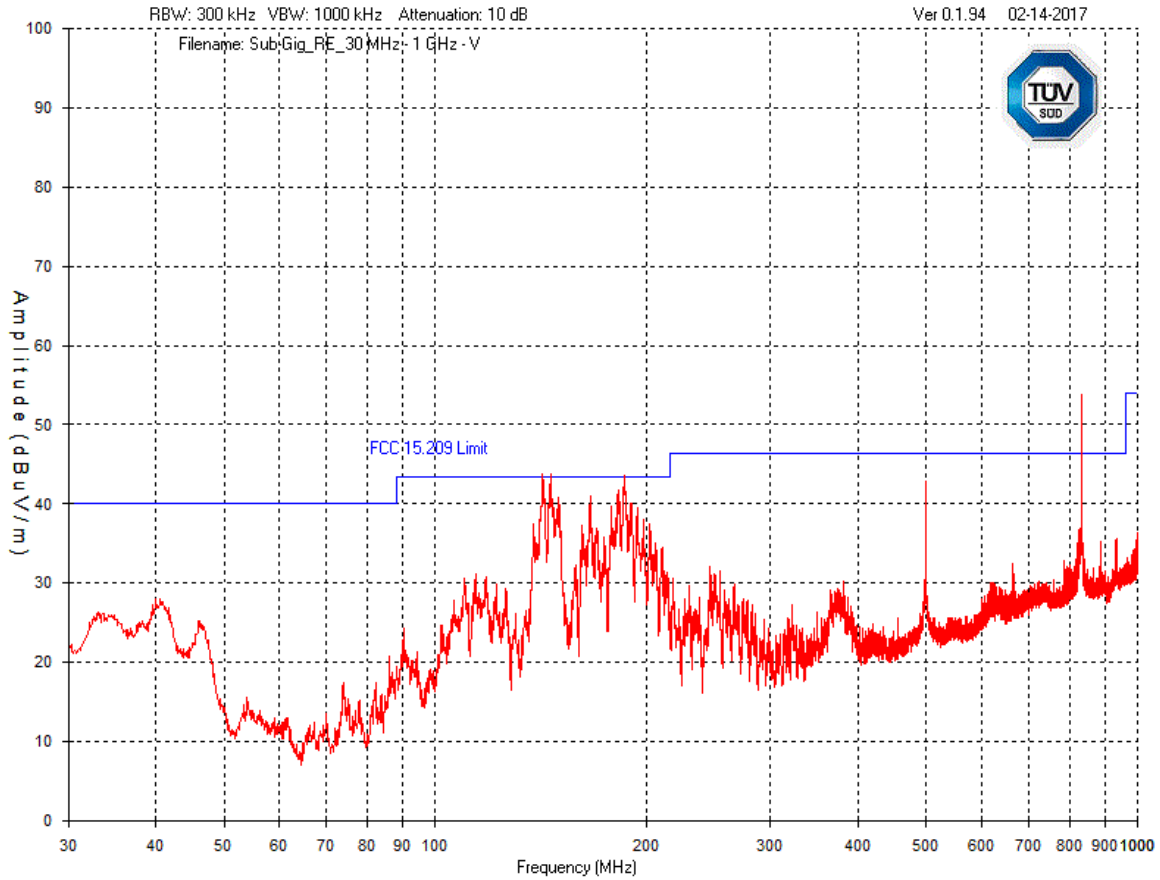

| | | |
|-------------|---|---|
| Client | Ecobee Inc. |  |
| Product | ECB401 | |
| Standard(s) | RSS 247 Issue 2:2017 FCC Part 15 Subpart 15.247:2015 | |

**Mid Channel – 30 MHz – 1 GHz
Horizontal - Peak Emission Graph**

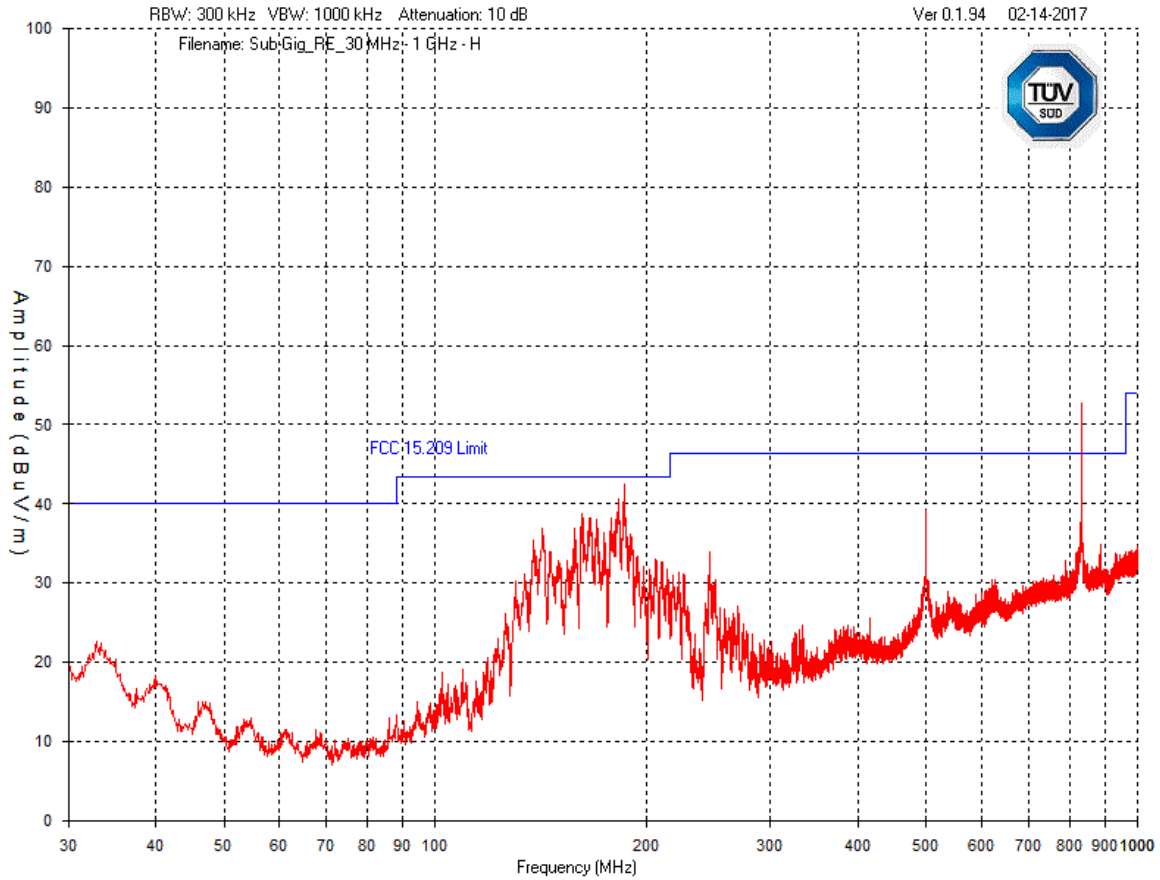

| | | |
|-------------|---|---|
| Client | Ecobee Inc. |  |
| Product | ECB401 | |
| Standard(s) | RSS 247 Issue 2:2017 FCC Part 15 Subpart 15.247:2015 | |

**Mid Channel – 1 GHz – 2 GHz
Vertical - Peak Emission Graph**

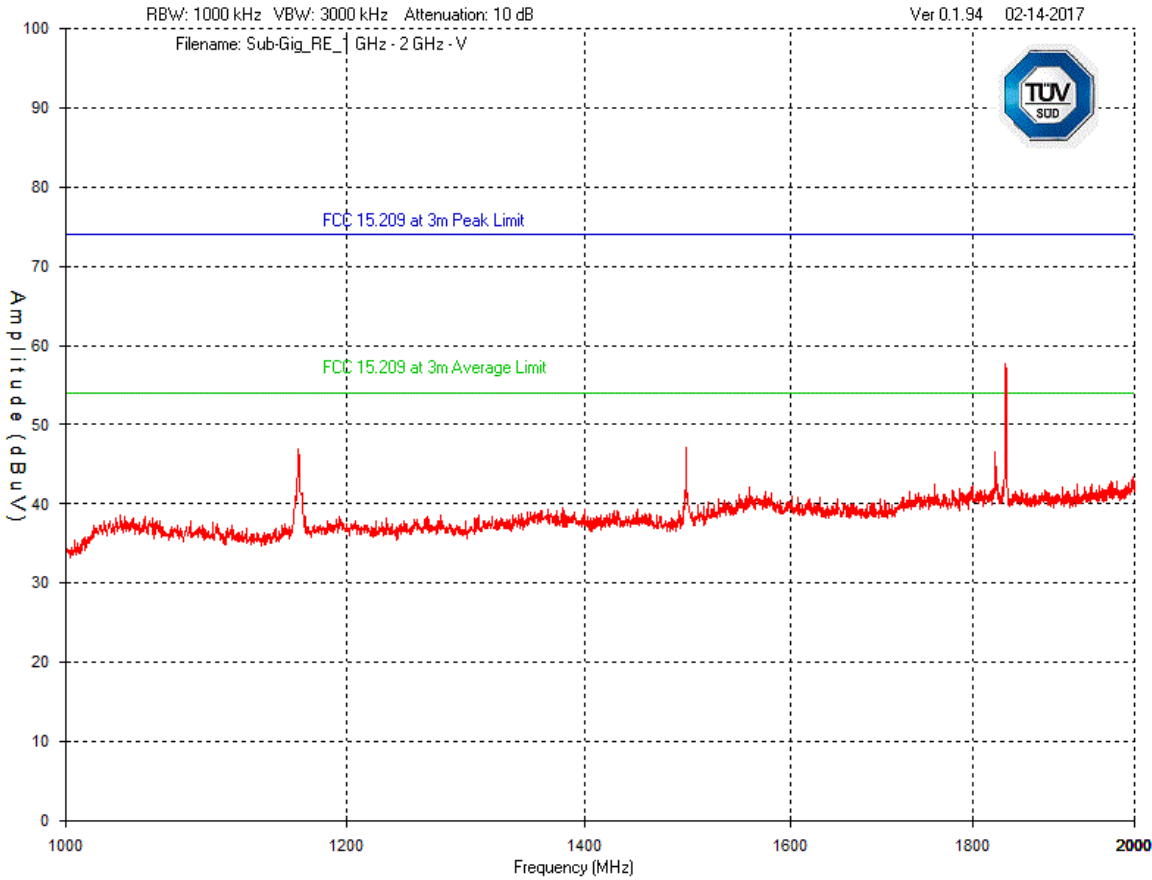

Note: See Final Measurements and Results section starting on page 42 for measurements.

| | | |
|-------------|---|---|
| Client | Ecobee Inc. |  |
| Product | ECB401 | |
| Standard(s) | RSS 247 Issue 2:2017 FCC Part 15 Subpart 15.247:2015 | |

**Mid Channel – 1 GHz – 2 GHz
Horizontal - Peak Emission Graph**

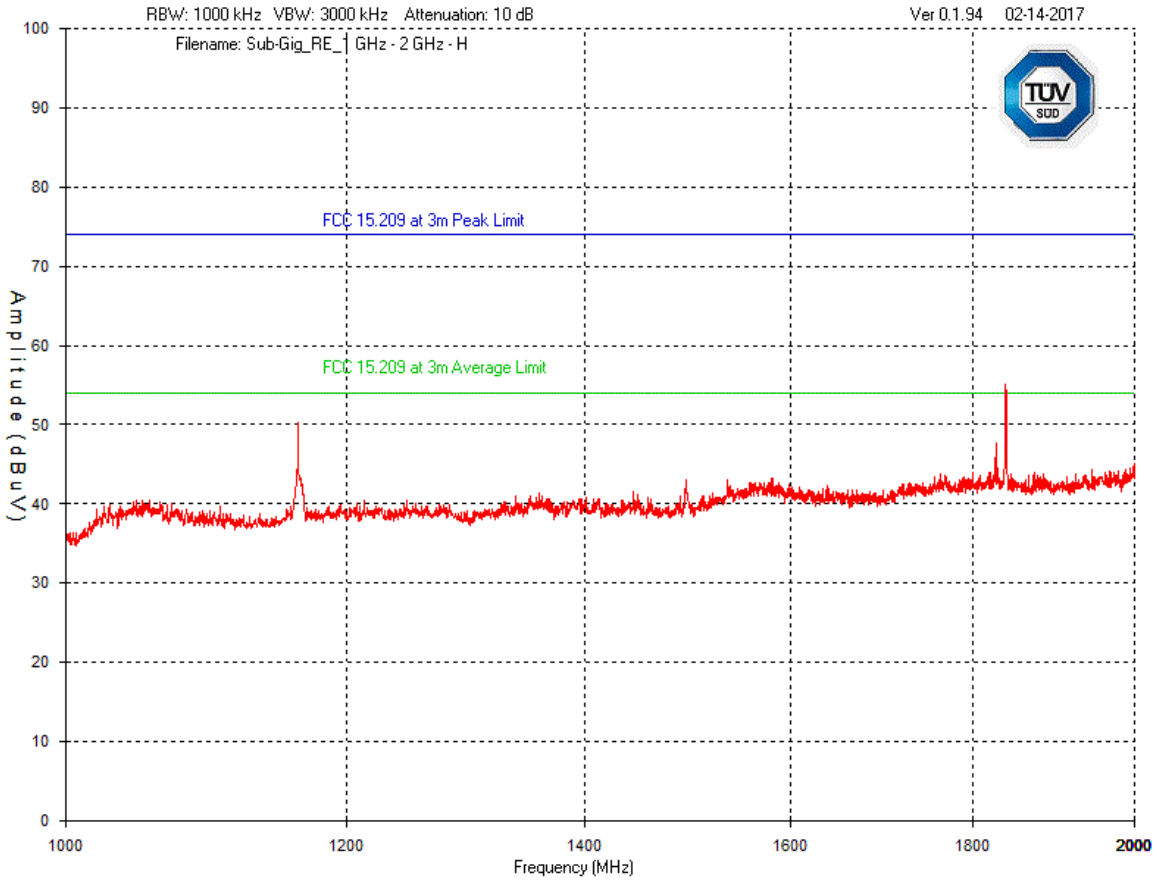

Note: See Final Measurements and Results section starting on page 42 for measurements.

| | | |
|-------------|---|---|
| Client | Ecobee Inc. |  |
| Product | ECB401 | |
| Standard(s) | RSS 247 Issue 2:2017 FCC Part 15 Subpart 15.247:2015 | |

**Mid Channel – 2 GHz – 10 GHz
Vertical - Peak Emission Graph**

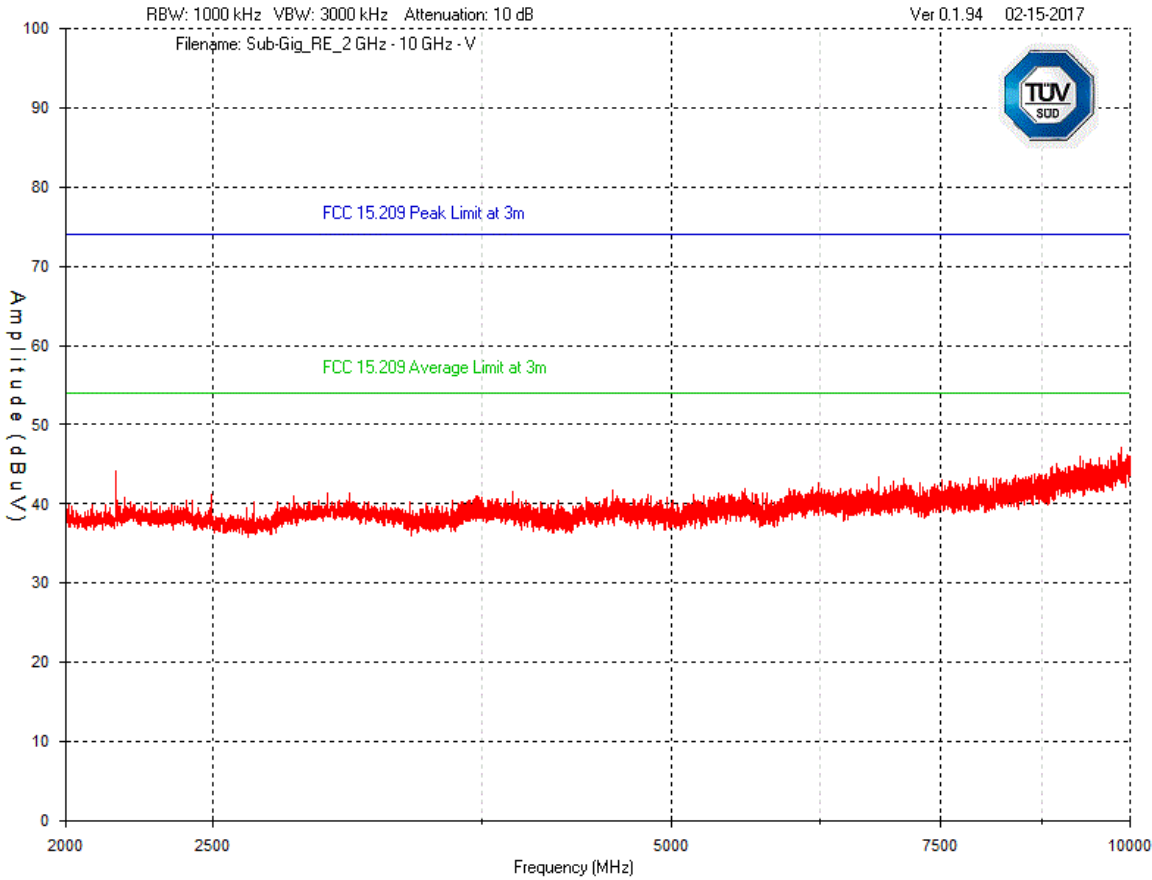

Note: See Final Measurements and Results section starting on page 42 for measurements.

| | | |
|-------------|---|---|
| Client | Ecobee Inc. |  |
| Product | ECB401 | |
| Standard(s) | RSS 247 Issue 2:2017 FCC Part 15 Subpart 15.247:2015 | |

**Mid Channel – 2 GHz – 10 GHz
Horizontal - Peak Emission Graph**

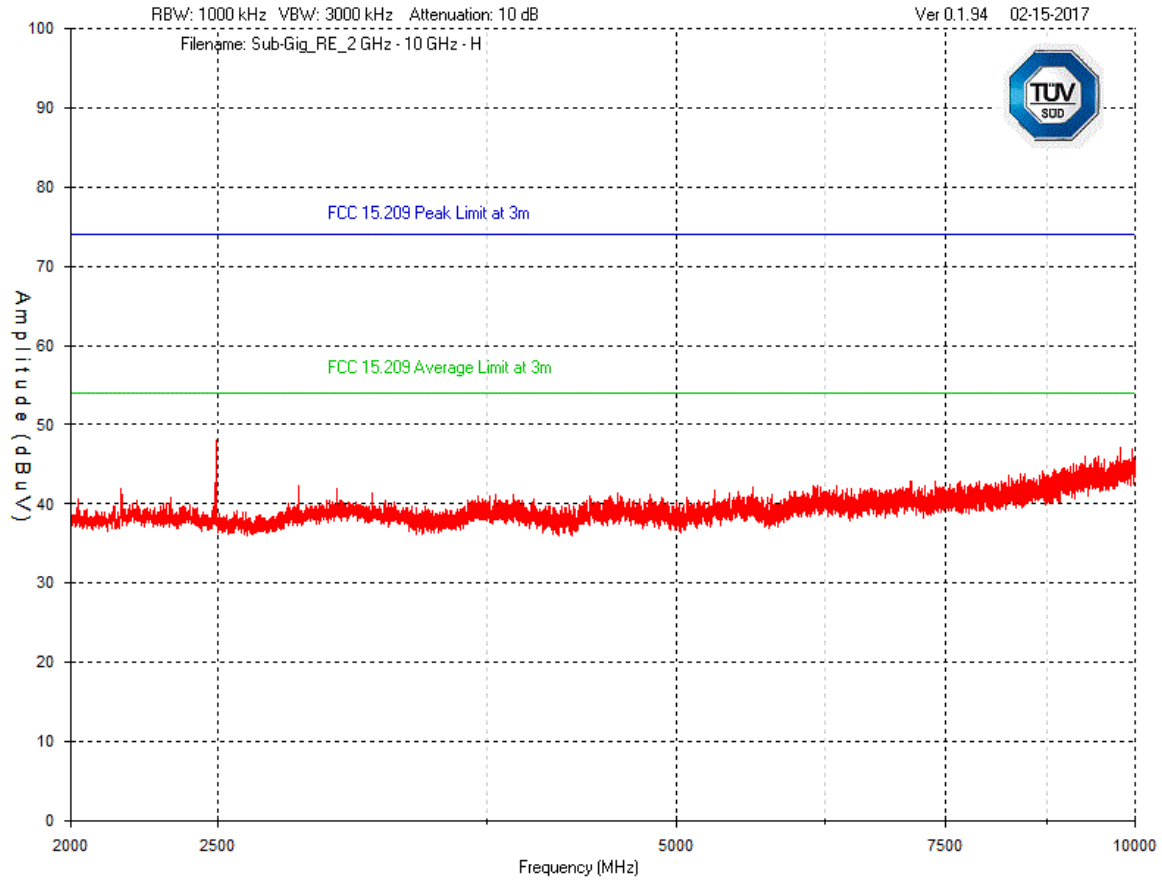

Note: See Final Measurements and Results section starting on page 42 for measurements.

| | | |
|-------------|---|---|
| Client | Ecobee Inc. |  |
| Product | ECB401 | |
| Standard(s) | RSS 247 Issue 2:2017 FCC Part 15 Subpart 15.247:2015 | |

Final Measurements and Results

The EUT passed the limits. Low, middle and high bands were measured.

In accordance with 15.247(d), only frequencies exceeding the 15.209 limit that occur within the bands listed in 15.205, need to be verified with a final detector. Emission outside the restricted bands were measured for information purpose.

The measurements were maximized by rotating the turn table over a full 0-360 rotation and the antenna height was varied from 1 m to 4 m.

| Product Category | | Class A | | | | | |
|---------------------------|----------|---------------|-------------------------|----------------|----------------|-------------|-----------|
| Product | | Ecobee3 Lite | | | | | |
| Supply | | 120 Vac 60 Hz | | | | | |
| Vertical Emission Table | | | | | | | |
| Frequency (MHz) | Detector | Raw (dBuV) | Correction Factors (dB) | Level (dBuV/m) | Limit (dBuV/m) | Margin (dB) | Pass/Fail |
| 830.929 | QP | 46.8 | -5.5 | 41.3 | 46.4 | 5.1 | Pass |
| 146.109 | QP | 61.9 | -23.9 | 38.0 | 43.5 | 5.5 | Pass |
| 141.938 | QP | 60.5 | -24.1 | 36.4 | 43.5 | 7.1 | Pass |
| 185.879 | QP | 62.6 | -22.2 | 40.4 | 43.5 | 3.1 | Pass |
| 831.22 | QP | 38.2 | -5.5 | 32.7 | 46.4 | 13.7 | Pass |
| 181.999 | QP | 60.2 | -22.6 | 37.6 | 43.5 | 5.9 | Pass |
| 165.994 | QP | 59.5 | -22.6 | 36.9 | 43.5 | 6.6 | Pass |
| 498.704 | QP | 40.7 | -14.3 | 26.4 | 46.4 | 20.0 | Pass |
| 1839.67 | AVG | 35.0 | -3.2 | 31.8 | 54.0 | 22.2 | Pass* |
| Horizontal Emission Table | | | | | | | |
| 831.026 | QP | 39.7 | -4.3 | 35.4 | 46.4 | 11.0 | Pass |
| 186.073 | QP | 55.8 | -22.1 | 33.7 | 43.5 | 9.8 | Pass |
| 181.999 | QP | 56.4 | -22.7 | 33.7 | 43.5 | 9.8 | Pass |
| 162.017 | QP | 55.7 | -23.4 | 32.3 | 43.5 | 11.2 | Pass |
| 166.188 | QP | 55.7 | -23.5 | 32.2 | 43.5 | 11.3 | Pass |
| 1839.33 | AVG, | 30.7 | -1.5 | 29.2 | 54.0 | 24.8 | Pass* |
| 1163 | AVG, | 36.7 | -7.3 | 29.4 | 54.0 | 24.6 | Pass |

| | | |
|-------------|---|---|
| Client | Ecobee Inc. |  |
| Product | ECB401 | |
| Standard(s) | RSS 247 Issue 2:2017 FCC Part 15 Subpart 15.247:2015 | |

*This is the 2nd harmonic of the transmitter. The Average emission was derived from adding duty cycle correction factor of -25.9 dB to the peak. The transmitter have an ON time of 5.08 ms in a 100 ms period.

Test Equipment List

| Equipment | Model No. | Manufacturer | Last Calibration Date | Next Calibration Date | Asset # |
|-----------------------------------|--------------------------------|--------------------|-----------------------|-----------------------|-----------|
| Spectrum Analyzer | ESU 40 | Rohde & Schwarz | Jan. 6, 2016 | Jan. 6, 2018 | GEMC 233 |
| Loop Antenna | EM 6871 | Electro-Metrics | Feb 13, 2017 | Feb 13, 2019 | GEMC 70 |
| Loop Antenna | EM 6872 | Electro-Metrics | Feb 13, 2017 | Feb 13, 2019 | GEMC 71 |
| BiLog Antenna | HLP-3003C | TDK RF Solutions | Oct. 12, 2016 | Oct. 12, 2018 | GEMC 231 |
| Horn Antenna 2 – 18 GHz | WBH218HN | Q-par | Feb. 12, 2016 | Feb. 12, 2018 | GEMC 6375 |
| Horn Antenna 18 GHz - 26.5 GHz | SAS-572 | A.H. Systems | Oct 11, 2016 | Oct 11, 2018 | GEMC 6371 |
| Pre-Amp 9 kHz – 1 GHz | CPA9231A | Chase | Oct 12, 2016 | Oct 12, 2018 | GEMC 6403 |
| Pre-Amp 1 – 26.5 GHz | HP 8449B | HP | Nov. 27, 2015 | Nov. 27, 2017 | GEMC 189 |
| Band Reject Filter | BRC50722 | Micro-Tronics | Apr 9, 2016 | Apr 9, 2017 | GEMC 186 |
| High pass filter | 5IH30-1078 | K & L Microwave | Apr 9, 2016 | Apr 9, 2017 | GEMC 118 |
| RF Cable 7m | LMR-400-7M- 50Ω-MN-MN | LexTec | Feb 13, 2017 | Feb 13, 2018 | GEMC 28 |
| RF Cable 10m | LMR-400-10M- 50Ω-MN-MN | LexTec | Feb 13, 2017 | Feb 13, 2018 | GEMC 27 |
| RF Cable 0.5m | LMR-400- 0.5M-50Ω-MN- MN | LexTec | Feb 13, 2017 | Feb 13, 2018 | GEMC 31 |
| RF Cable 1m | LMR-400-1M- 50OHM-MN-MN | LexTec | Feb 13, 2017 | Feb 13, 2018 | GEMC 29 |
| Emissions Software | 0.1.94 | Global EMC | NCR | NCR | GEMC 58 |

This report module is based on template "FCC - 15.209 - Radiated Emissions_Rev1.doc"

| | | |
|-------------|---|---|
| Client | Ecobee Inc. |  |
| Product | ECB401 | |
| Standard(s) | RSS 247 Issue 2:2017 FCC Part 15 Subpart 15.247:2015 | |

Power Line Conducted Emissions

Purpose

The purpose of this test is to ensure that the RF energy unintentionally emitted from the EUT's power line does not exceed the limits listed below as defined in the applicable test standard and measured from a LISN. This helps protect lower frequency radio services such as AM radio, shortwave radio, amateur radio, maritime radio, CB radio, and so on, from unwanted interference.

Limits & Method

The method is as defined in ANSI C63.10. The limits are as defined in FCC Part 15 Section 15.207 and RSS-GEN:

| Average Limits | | Quasi-Peak Limits | |
|-----------------------|----------------------|--------------------------|----------------------|
| 150 kHz – 500 kHz | 56 to 46* dB μ V | 150 kHz – 500 kHz | 66 to 56* dB μ V |
| 500 kHz – 5 MHz | 46 dB μ V | 500 kHz – 5 MHz | 56 dB μ V |
| 5 MHz – 30 MHz | 50 dB μ V | 5 MHz – 30 MHz | 60 dB μ V |

* Decreases linearly with the logarithm of the frequency

Both Quasi-Peak and Average limits are applicable and each is specified as being measured with a resolution bandwidth of 9 kHz. For Quasi-Peak, a video bandwidth at least three times greater than the resolution bandwidth is used.

If the Peak or Quasi-Peak detector measurements do not exceed the Average limits, then the EUT is deemed to have passed the requirements.

| | | |
|-------------|---|---|
| Client | Ecobee Inc. |  Canada |
| Product | ECB401 | |
| Standard(s) | RSS 247 Issue 2:2017 FCC Part 15 Subpart 15.247:2015 | |

Typical Setup Diagram

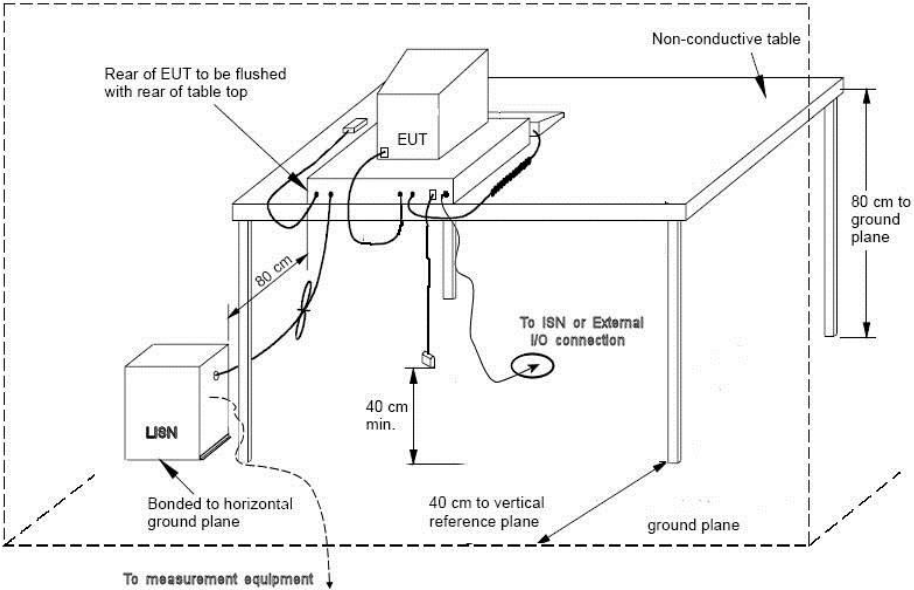

Measurement Uncertainty

The expanded measurement uncertainty is calculated in accordance with CISPR 16-4-2 and is $\pm 2.91\text{dB}$ with a 'k=2' coverage factor and a 95% confidence level.

Preliminary Graphs

The graphs shown below are maximized peak measurement graphs measured with a resolution bandwidth greater than or equal to the final required detector. This peaking process is done as a worst case measurement and enables the detection of frequencies of concern for final measurement. For final measurements with the appropriate detector, where applicable, please refer to the tables under Final Measurements.

© TÜV SÜD Canada Inc. This test report shall not be reproduced except in full, without written approval of TÜV SÜD Canada Inc

| | | |
|-------------|---|---|
| Client | Ecobee Inc. |  |
| Product | ECB401 | |
| Standard(s) | RSS 247 Issue 2:2017 FCC Part 15 Subpart 15.247:2015 | |

Line (L1) – 120Vac 60Hz

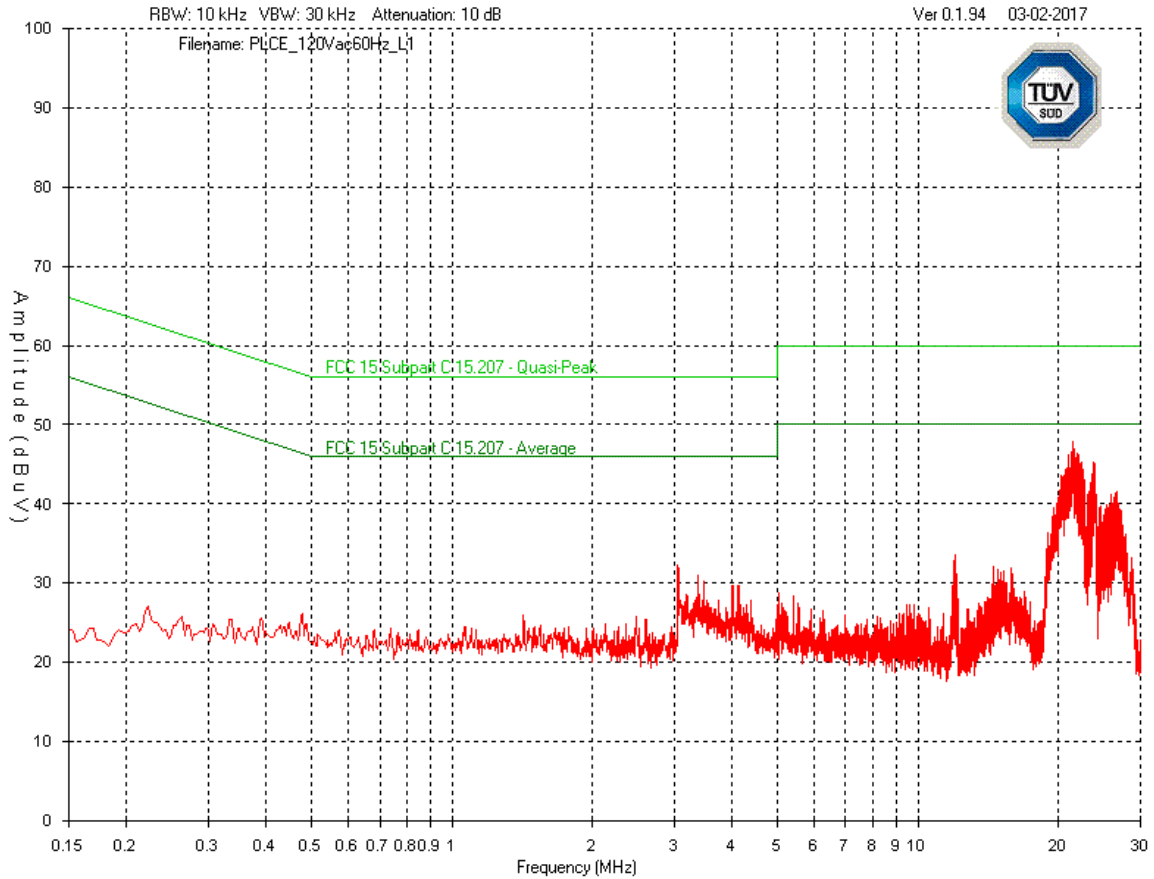

| | | |
|-------------|---|---|
| Client | Ecobee Inc. |  |
| Product | ECB401 | |
| Standard(s) | RSS 247 Issue 2:2017 FCC Part 15 Subpart 15.247:2015 | |

Neutral (L2) – 120Vac 60Hz

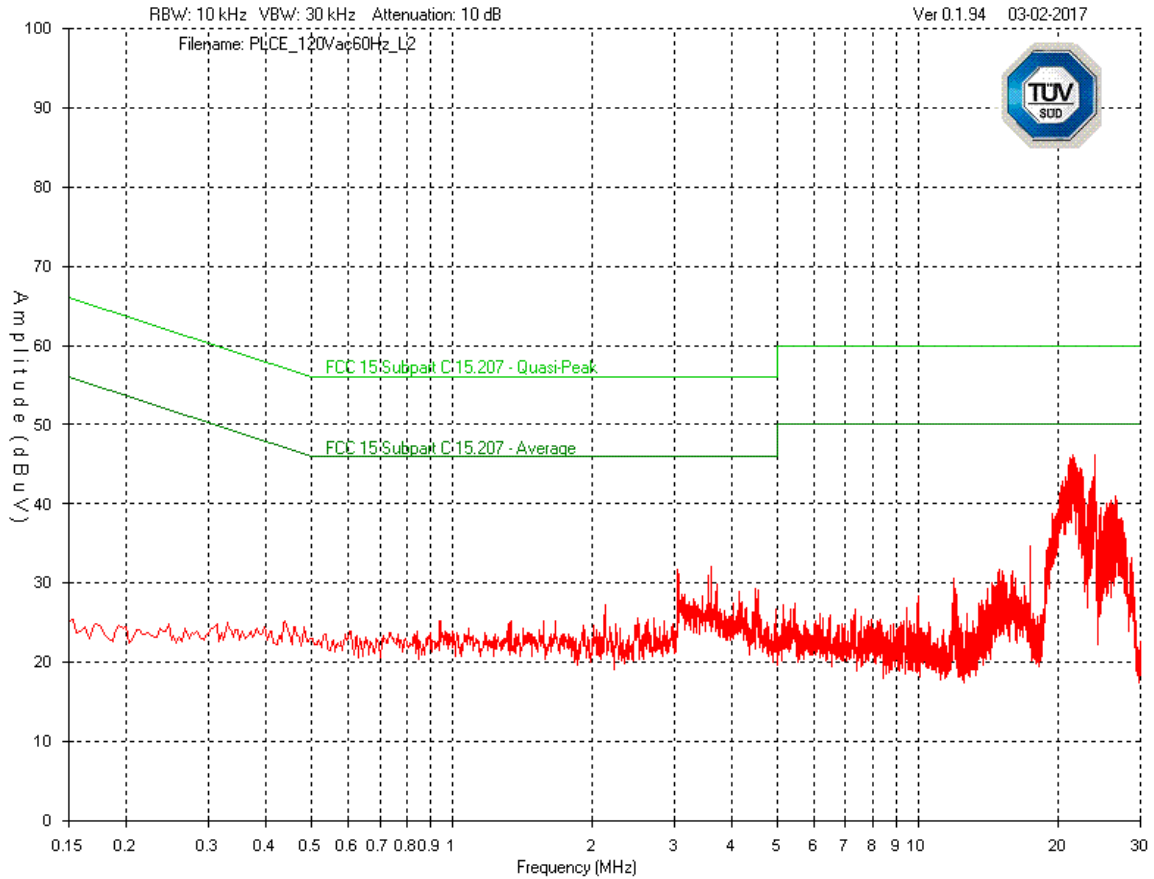

| | | |
|-------------|---|---|
| Client | Ecobee Inc. |  |
| Product | ECB401 | |
| Standard(s) | RSS 247 Issue 2:2017 FCC Part 15 Subpart 15.247:2015 | |

Final Measurements

All peak emission were below the average limit thus the EUT was deemed to meet power line conducted emission limits based on peak emission.

See 'Appendix B – EUT, Peripherals and Test Setup Photos' for photos showing the test set-up for the highest line conducted emission

Test Equipment List

| Equipment | Model No. | Manufacturer | Last Calibration Date | Next Calibration Date | Asset # |
|--------------------|-------------------------|-----------------|-----------------------|-----------------------|----------|
| Spectrum Analyzer | ESL 6 | Rohde & Schwarz | Nov. 25, 2015 | Nov. 25, 2017 | GEMC 160 |
| LISN | FCC-LISN-50/250-16-2-01 | FCC | Feb 1, 2017 | Feb 1, 2019 | GEMC 65 |
| RF Cable 7m | LMR-400-7M-50Ω-MN-MN | LexTec | NCR | NCR | GEMC 28 |
| 10dB Attenuator | FP-50-10 | Trilithic | NCR | NCR | GEMC 42 |
| Emissions Software | 0.1.94 | TUV SUD Canada | NCR | NCR | GEMC 58 |

This report module is based on report template 'FCC_ICES003_CE_Rev1'

| | | |
|-------------|---|---|
| Client | Ecobee Inc. |  Canada |
| Product | ECB401 | |
| Standard(s) | RSS 247 Issue 2:2017 FCC Part 15 Subpart 15.247:2015 | |

Appendix A – EUT Summary

| | | |
|-------------|---|---|
| Client | Ecobee Inc. |  |
| Product | ECB401 | |
| Standard(s) | RSS 247 Issue 2:2017 FCC Part 15 Subpart 15.247:2015 | |

For further details for filing purposes, refer to filing package.

General EUT Description

| Client | |
|--------------------------------|--|
| Organization / Address | Ecobee Inc 250 University Avenue, Suite 400 Toronto, ON M5H 3E5 |
| Contact | Kashif Ahmed |
| Phone | 416 987 1048 |
| Email | kashif@ecobee.com |
| EUT Details | |
| EUT Name | ECB401 |
| FCC ID | WR9116151212151 |
| Industry Canada # | 7981A-11615121215 |
| Equipment Category | Low power wireless thermostat |
| Basic EUT Functionality | EUT is a smart thermostat that have a 2400 – 2483.5 MHz DTS (802.11 b/g/n) transmitter and a 902 – 928 MHz FHSS transmitter. |
| Input Voltage and Frequency | 24 Vac 60 Hz |
| Rated Input Current | 2 A |
| Connectors available on EUT | 1 (terminals for HVAC control) |
| Peripherals Required for Test | None |
| Release type | Final |
| Intentional Radiator Frequency | 2400 – 2483.5 MHz for 802.11 b/g/n DTS 902 – 928 MHz FHSS |
| EUT Configuration | Wireless configured to transmit continuously at 100% duty cycle |

Note the EUT is considered to have been received the date of the commencement of the first test, unless otherwise stated. For a close-up picture of the EUT, see ‘Appendix B – EUT and Test Setup Photos’.

| | | |
|-------------|---|---|
| Client | Ecobee Inc. |  |
| Product | ECB401 | |
| Standard(s) | RSS 247 Issue 2:2017 FCC Part 15 Subpart 15.247:2015 | |

EUT Configuration

Please see Appendix B for a picture of the unit running in normal conditions.

- Wireless were configured to transmit at maximum possible duty cycle
- The 15.247 902 – 928 MHz transmitter were configure with the following settings:
 - A special test firmware were installed on the EUT to control hopping through its pseudo random sequence with the command o1.
 - c# to transmit on single channels.

Operational Setup

These devices are required to be attached to the EUT for its normal operation.

- A debug board was connected to the EUT to issue test commands.