

EMC Test Report

Application for Grant of Equipment Authorization

Industry Canada RSS-Gen Issue 4 / RSS 210 Issue 8 FCC Part 15 Subpart C

Model: R2Lite FH915 Radio

IC CERTIFICATION #: 6050B-R2LITEFH915
FCC ID: WR4-R2LITEFH915

APPLICANT: Topcon Positioning Systems
7400 National Dr.
Livermore, CA 94550

TEST SITE(S): National Technical Systems - Silicon Valley
41039 Boyce Road.
Fremont, CA. 94538-2435

IC SITE REGISTRATION #: 2845B-5, 2845B-7

REPORT DATE: November 12, 2015

REISSUE DATE: August 12, 2016

FINAL TEST DATES: May 5, 6, July 9, 15, September 8, 9, 14 and
November 3, 2015

TOTAL NUMBER OF PAGES: 47

PROGRAM MGR /
TECHNICAL REVIEWER:

QUALITY ASSURANCE DELEGATE /
FINAL REPORT PREPARER:



Deniz Demirci
Senior Wireless / EMC Engineer



David Guidotti
Senior Technical Writer



National Technical Systems - Silicon Valley is accredited by the A2LA, certificate number 0214.26, to perform the test(s) listed in this report, except where noted otherwise. This report and the information contained herein represent the results of testing test articles identified and selected by the client performed to specifications and/or procedures selected by the client. National Technical Systems (NTS) makes no representations, expressed or implied, that such testing is adequate (or inadequate) to demonstrate efficiency, performance, reliability, or any other characteristic of the articles being tested, or similar products. This report should not be relied upon as an endorsement or certification by NTS of the equipment tested, nor does it represent any statement whatsoever as to its merchantability or fitness of the test article, or similar products, for a particular purpose. This report shall not be reproduced except in full

REVISION HISTORY

Rev#	Date	Comments	Modified By
-	November 12, 2015	First release	-
1	March 22, 2016	Antenna gain information updated.	Deniz Demirci
2	March 29, 2016	EUT description is updated.	Deniz Demirci
3	August 12, 2016	EUT description is updated as battery operated device and removed Conducted emissions data.	Deniz Demirci

TABLE OF CONTENTS

REVISION HISTORY	2
TABLE OF CONTENTS	3
SCOPE	4
OBJECTIVE	5
STATEMENT OF COMPLIANCE	5
DEVIATIONS FROM THE STANDARDS	6
TEST RESULTS SUMMARY	7
FREQUENCY HOPPING SPREAD SPECTRUM (902 – 928 MHZ, 50 CHANNELS OR MORE)	7
GENERAL REQUIREMENTS APPLICABLE TO ALL BANDS	7
MEASUREMENT UNCERTAINTIES	8
EQUIPMENT UNDER TEST (EUT) DETAILS	9
GENERAL.....	9
ANTENNA SYSTEM	9
ENCLOSURE	9
MODIFICATIONS	9
SUPPORT EQUIPMENT	9
EUT INTERFACE PORTS	10
EUT OPERATION	10
TEST SITE	11
GENERAL INFORMATION	11
RADIATED EMISSIONS CONSIDERATIONS	11
MEASUREMENT INSTRUMENTATION	12
RECEIVER SYSTEM	12
INSTRUMENT CONTROL COMPUTER	12
FILTERS/ATTENUATORS	13
ANTENNAS.....	13
ANTENNA MAST AND EQUIPMENT TURNTABLE	13
INSTRUMENT CALIBRATION.....	13
TEST PROCEDURES	14
EUT AND CABLE PLACEMENT	14
RADIATED EMISSIONS	15
CONDUCTED EMISSIONS FROM ANTENNA PORT	17
BANDWIDTH MEASUREMENTS	17
SPECIFICATION LIMITS AND SAMPLE CALCULATIONS	18
GENERAL TRANSMITTER RADIATED EMISSIONS SPECIFICATION LIMITS	19
RECEIVER RADIATED SPURIOUS EMISSIONS SPECIFICATION LIMITS	19
OUTPUT POWER LIMITS – FHSS SYSTEMS	19
TRANSMIT MODE SPURIOUS RADIATED EMISSIONS LIMITS – FHSS AND DTS SYSTEMS	20
SAMPLE CALCULATIONS - RADIATED EMISSIONS	20
APPENDIX A TEST EQUIPMENT CALIBRATION DATA	21
APPENDIX B TEST DATA	23
END OF REPORT	47

SCOPE

An electromagnetic emissions test has been performed on the Topcon Positioning Systems model R2Lite FH915 Radio, pursuant to the following rules:

Subpart C of Part 15 of FCC Rules (CFR 47), Intentional Radiators

RSS-Gen Issue 4 “General Requirements for Compliance of Radio Apparatus”

RSS-247 Issue 1 “Digital Transmission Systems (DTSS), Frequency Hopping Systems (FHSs) and Licence-Exempt Local Area Network (LE-LAN) Devices”

Conducted and radiated emissions data has been collected, reduced, and analyzed within this report in accordance with measurement guidelines set forth in the following reference standards and as outlined in National Technical Systems - Silicon Valley test procedures:

ANSI C63.10-2013

FHSS test procedure DA 00-0705A1

The intentional radiator above has been tested in a simulated typical installation to demonstrate compliance with the relevant Industry Canada performance and procedural standards.

Final system data was gathered in a mode that tended to maximize emissions by varying orientation of EUT, orientation of power and I/O cabling, antenna search height, and antenna polarization.

Every practical effort was made to perform an impartial test using appropriate test equipment of known calibration. All pertinent factors have been applied to reach the determination of compliance.

OBJECTIVE

The primary objective of the manufacturer is compliance with the regulations outlined in the previous section.

Prior to marketing in the USA, all unlicensed transmitters and transceivers require certification. Receive-only devices operating between 30 MHz and 960 MHz are subject to either certification or a manufacturer's declaration of conformity, with all other receive-only devices exempt from the technical requirements.

Prior to marketing in Canada, Class I transmitters, receivers and transceivers require certification. Class II devices are required to meet the appropriate technical requirements but are exempt from certification requirements.

Certification is a procedure where the manufacturer submits test data and technical information to a certification body and receives a certificate or grant of equipment authorization upon successful completion of the certification body's review of the submitted documents. Once the equipment authorization has been obtained, the label indicating compliance must be attached to all identical units, which are subsequently manufactured.

Maintenance of compliance is the responsibility of the manufacturer. Any modification of the product which may result in increased emissions should be checked to ensure compliance has been maintained (i.e., printed circuit board layout changes, different line filter, different power supply, harnessing or I/O cable changes, etc.).

Testing was performed only on model R2Lite FH915 Radio.

STATEMENT OF COMPLIANCE

The tested sample of Topcon Positioning Systems model R2Lite FH915 Radio complied with the requirements of the following regulations:

Industry Canada RSS-Gen Issue 4

RSS-247 Issue 1 "Digital Transmission Systems (DTSs), Frequency Hopping Systems (FHSs) and Licence-Exempt Local Area Network (LE-LAN) Devices"

FCC Part 15 Subpart C

Maintenance of compliance is the responsibility of the manufacturer. Any modifications to the product should be assessed to determine their potential impact on the compliance status of the device with respect to the standards detailed in this test report.

The test results recorded herein are based on a single type test of Topcon Positioning Systems model R2Lite FH915 Radio and therefore apply only to the tested sample. The sample was selected and prepared by Ferdinand Riodique of Topcon Positioning Systems.

DEVIATIONS FROM THE STANDARDS

No deviations were made from the published requirements listed in the scope of this report.

TEST RESULTS SUMMARY
FREQUENCY HOPPING SPREAD SPECTRUM (902 – 928 MHz, 50 channels or more)

FCC Rule Part	RSS Rule Part	Description	Measured Value / Comments	Limit / Requirement	Result
15.247 (a) (1)	RSS 247 5.1. (3)	20 dB Bandwidth	155 kHz	Channel spacing > 20dB bandwidth / 25kHz	Complies
		Channel Separation	200 kHz		Complies
15.247 (a) (1) (i)	RSS 247 5.1. (3)	Number of Channels	128	50 or more	Complies
15.247 (a) (1) (i)	RSS 247 5.1. (3)	Channel Dwell Time	172 ms per 20 s	<0.4 second within a 20 second period	Complies
15.247 (a) (1)	RSS 247 5.1. (3)	Channel Utilization	All channels are used equally - refer to the operational description for full explanation	All channels shall, on average, be used equally	Complies
15.247 (b) (3)	RSS 247 5.4. (1)	Output Power	29.8 dBm (0.955 W) EIRP = 2.399 W <small>Note 1</small>	1 Watt, EIRP < 4 Watts	Complies
15.247 (c)	RSS 247 5.5.	Antenna Port Spurious Emissions 30 MHz – 9.28 GHz	All spurious emissions < -20 dBc	< -20 dBc	Complies
15.247 (c) 15.209	RSS 247 5.5	Radiated Spurious Emissions 30 MHz – 9.28 GHz	50.7 dBμV/m @ 7421.1 MHz (-3.3 dB)	15.207 in restricted bands, all others < -20 dBc	Complies
-	-	Receiver bandwidth	-	Not required for 902 – 928 FHSS	-
Note 1: EIRP calculated using antenna gain of 4 dBi for the highest EIRP system.					

GENERAL REQUIREMENTS APPLICABLE TO ALL BANDS

FCC Rule Part	RSS Rule part	Description	Measured Value / Comments	Limit / Requirement	Result (margin)
15.203	-	RF Connector	Reverse TNC	Unique or integral antenna required	Complies
15.207	RSS GEN Table 3	AC Conducted Emissions	N/A	N/A – Battery operated	N/A
15.109	-	Receiver spurious emissions	28.8 dBμV/m @ 800.00 MHz	Refer to page 19	Complies (- 17.2 dB)
15.247 (b) (5) 15.407 (f)	RSS 102	RF Exposure Requirements	Refer to MPE calculations in separate exhibit, RSS 102 declaration and User Manual statements.	Refer to OET 65, FCC Part 1 and RSS 102	Complies
-	RSS GEN 8.3	User Manual	-	Statement for products with detachable antenna	Complies
-	RSP 100 RSS GEN 6.6	Occupied Bandwidth	155 kHz (20 dB)	Information only	N/A

MEASUREMENT UNCERTAINTIES

ISO/IEC 17025 requires that an estimate of the measurement uncertainties associated with the emissions test results be included in the report. The measurement uncertainties given below are based on a 95% confidence level and were calculated in accordance with UKAS document LAB 34.

Measurement Type	Measurement Unit	Frequency Range	Expanded Uncertainty
RF power, conducted (power meter)	dBm	25 to 7000 MHz	± 0.52 dB
RF power, conducted (Spectrum analyzer)	dBm	25 to 7000 MHz	± 0.7 dB
Conducted emission of transmitter	dBm	25 to 26500 MHz	± 0.7 dB
Conducted emission of receiver	dBm	25 to 26500 MHz	± 0.7 dB
Radiated emission (substitution method)	dBm	25 to 26500 MHz	± 2.5 dB
Radiated emission (field strength)	dB μ V/m	25 to 1000 MHz	± 3.6 dB
		1000 to 40000 MHz	± 6.0 dB

EQUIPMENT UNDER TEST (EUT) DETAILS**GENERAL**

The Topcon Positioning Systems model R2Lite FH915 Radio is a 1 W frequency hopping spread spectrum transceiver module with Tx/Rx frequency range from 902 MHz to 928 MHz. The host unit for the EUT will be internally battery powered.

The sample was received on May 5, 2015 and tested on May 5, 6, July 9, 15, September 8, 9, 14 and November 3, 2015. The EUT consisted of the following component(s):

Company	Model	Description	Serial Number	FCC ID
Topcon	R2Lite FH915	915 MHz FHSS Transceiver Module	F006216100001	FCC ID: WR4-R2LITEFH915 IC: 6050B-R2LITEFH915

ANTENNA SYSTEM

Monopole with reverse TNC connector, 4.0 dBi

ENCLOSURE

The EUT is a Radio module. The module is primarily constructed with aluminum RF shield. It measures approximately 46 mm wide by 80 mm deep by 12 mm high.

MODIFICATIONS

No modifications were made to the EUT during the time the product was at NTS Silicon Valley.

SUPPORT EQUIPMENT

The following equipment was used as support equipment for testing:

Company	Model	Description	Serial Number	FCC ID
Topcon	NA	Test fixture	NA	-
Topcon	NA	3.7 VDC Lithium ion battery pack (2 cells)	NA	-

No remote support equipment was used during testing.

EUT INTERFACE PORTS

The I/O cabling configuration during testing was as follows:

Port		Cable(s)		
From	To	Description	Shielded/Unshielded	Length(m)
Antenna	Antenna	Coax	Shielded	0.1
DC power	Battery pack	2 wire	Unshielded	0.1

EUT OPERATION

During emissions testing the 915 MHz FHSS radio was configured to transmit at rated power with frequencies and modulations indicated in each run.

TEST SITE**GENERAL INFORMATION**

Final test measurements were taken at the test sites listed below. Pursuant to section 2.948 of the FCC's Rules and section 3.3 of RSP-100, construction, calibration, and equipment data has been filed with the Commission and with industry Canada.

Site	Designation / Registration Numbers		Location
	FCC	Canada	
Chamber 5	US0027	2845B-5	41039 Boyce Road Fremont, CA 94538-2435
Chamber 7	US0027	2845B-7	

ANSI C63.4 recommends that ambient noise at the test site be at least 6 dB below the allowable limits. Ambient levels are below this requirement. The test site(s) contain separate areas for radiated and conducted emissions testing. Considerable engineering effort has been expended to ensure that the facilities conform to all pertinent requirements of ANSI C63.4.

RADIATED EMISSIONS CONSIDERATIONS

The FCC has determined that radiation measurements made in a shielded enclosure are not suitable for determining levels of radiated emissions. Radiated measurements are performed in a semi-anechoic chamber. The test sites are maintained free of conductive objects within the CISPR defined elliptical area incorporated in ANSI C63.4 guidelines and meet the Normalized Site Attenuation (NSA) requirements of ANSI C63.4.

MEASUREMENT INSTRUMENTATION

RECEIVER SYSTEM

An EMI receiver as specified in CISPR 16-1-1 is used for emissions measurements. The receivers used can measure over the frequency range of 9 kHz up to 2000 MHz. These receivers allow both ease of measurement and high accuracy to be achieved. The receivers have Peak, Average, and CISPR (Quasi-peak) detectors built into their design so no external adapters are necessary. The receiver automatically sets the required bandwidth for the CISPR detector used during measurements. If the repetition frequency of the signal being measured is below 20Hz, peak measurements are made in lieu of Quasi-Peak measurements.

For measurements above the frequency range of the receivers, a spectrum analyzer is utilized because it provides visibility of the entire spectrum along with the precision and versatility required to support engineering analysis. Average measurements above 1000 MHz are performed on the spectrum analyzer using the linear-average method with a resolution bandwidth of 1 MHz and a video bandwidth of 10 Hz, unless the signal is pulsed in which case the average (or video) bandwidth of the measuring instrument is reduced to onset of pulse desensitization and then increased.

INSTRUMENT CONTROL COMPUTER

The receivers utilize either a Rohde & Schwarz EZM Spectrum Monitor/Controller or contain an internal Spectrum Monitor/Controller to view and convert the receiver measurements to the field strength at an antenna or voltage developed at the LISN measurement port, which is then compared directly with the appropriate specification limit. This provides faster, more accurate readings by performing the conversions described under Sample Calculations within the Test Procedures section of this report. Results are printed in a graphic and/or tabular format, as appropriate. A personal computer is used to record all measurements made with the receivers. The software used for radiated and conducted emissions measurements is NTS EMI Test Software (rev 2.10)

The Spectrum Monitor provides a visual display of the signal being measured. In addition, the controller or a personal computer run automated data collection programs which control the receivers. This provides added accuracy since all site correction factors, such as cable loss and antenna factors are added automatically.

FILTERS/ATTENUATORS

External filters and precision attenuators are often connected between the receiving antenna or LISN and the receiver. This eliminates saturation effects and non-linear operation due to high amplitude transient events.

ANTENNAS

A loop antenna is used below 30 MHz. For the measurement range 30 MHz to 1000 MHz either a combination of a biconical antenna and a log periodic or a bi-log antenna is used. Above 1000 MHz, horn antennas are used. The antenna calibration factors to convert the received voltage to an electric field strength are included with appropriate cable loss and amplifier gain factors to determine an overall site factor, which is then programmed into the test receivers or incorporated into the test software.

ANTENNA MAST AND EQUIPMENT TURNTABLE

The antennas used to measure the radiated electric field strength are mounted on a non-conductive antenna mast equipped with a motor-drive to vary the antenna height. Measurements below 30 MHz are made with the loop antenna at a fixed height of 1m above the ground plane.

ANSI C63.10 specifies that the test height above ground for table mounted devices shall be 0.8 m below 1 GHz measurements and 1.5 m above 1 GHz measurements. During radiated measurements, the EUT is positioned on a motorized turntable in conformance with this requirement.

INSTRUMENT CALIBRATION

All test equipment is regularly checked to ensure that performance is maintained in accordance with the manufacturer's specifications. All antennas are calibrated at regular intervals with respect to tuned half-wave dipoles. An exhibit of this report contains the list of test equipment used and calibration information.

TEST PROCEDURES**EUT AND CABLE PLACEMENT**

The regulations require that interconnecting cables be connected to the available ports of the unit and that the placement of the unit and the attached cables simulate the worst case orientation that can be expected from a typical installation, so far as practicable. To this end, the position of the unit and associated cabling is varied within the guidelines of ANSI C63.10, and the worst-case orientation is used for final measurements.

RADIATED EMISSIONS

A preliminary scan of the radiated emissions is performed in which all significant EUT frequencies are identified with the system in a nominal configuration. At least two scans are performed, one scan for each antenna polarization (horizontal and vertical; loop parallel and perpendicular to the EUT). During the preliminary scans, the EUT is rotated through 360°, the antenna height is varied (for measurements above 30 MHz) and cable positions are varied to determine the highest emission relative to the limit. Preliminary scans may be performed in a fully anechoic chamber for the purposes of identifying the frequencies of the highest emissions from the EUT.

A speaker is provided in the receiver to aid in discriminating between EUT and ambient emissions. Other methods used during the preliminary scan for EUT emissions involve scanning with near field magnetic loops, monitoring I/O cables with RF current clamps, and cycling power to the EUT.

Final maximization is a phase in which the highest amplitude emissions identified in the spectral search are viewed while the EUT azimuth angle is varied from 0 to 360 degrees relative to the receiving antenna. The azimuth, which results in the highest emission is then maintained while varying the antenna height from one to four meters (for measurements above 30 MHz, measurements below 30 MHz are made with the loop antenna at a fixed height of 1m). The result is the identification of the highest amplitude for each of the highest peaks. Each recorded level is corrected in the receiver using appropriate factors for cables, connectors, antennas, and preamplifier gain.

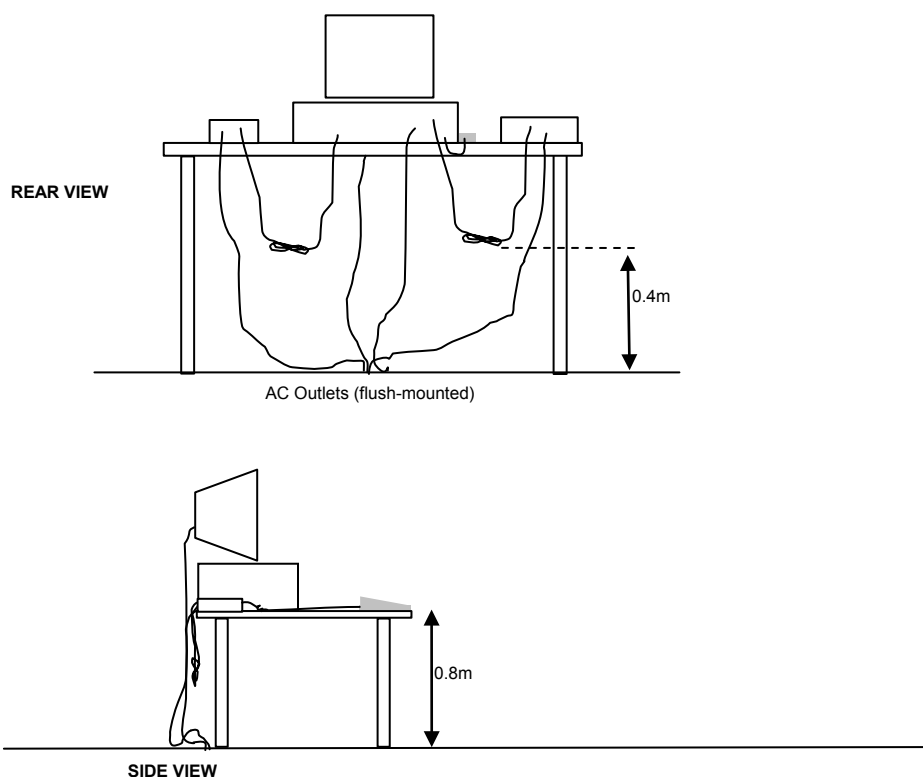

Typical Test Configuration for Radiated Field Strength Measurements

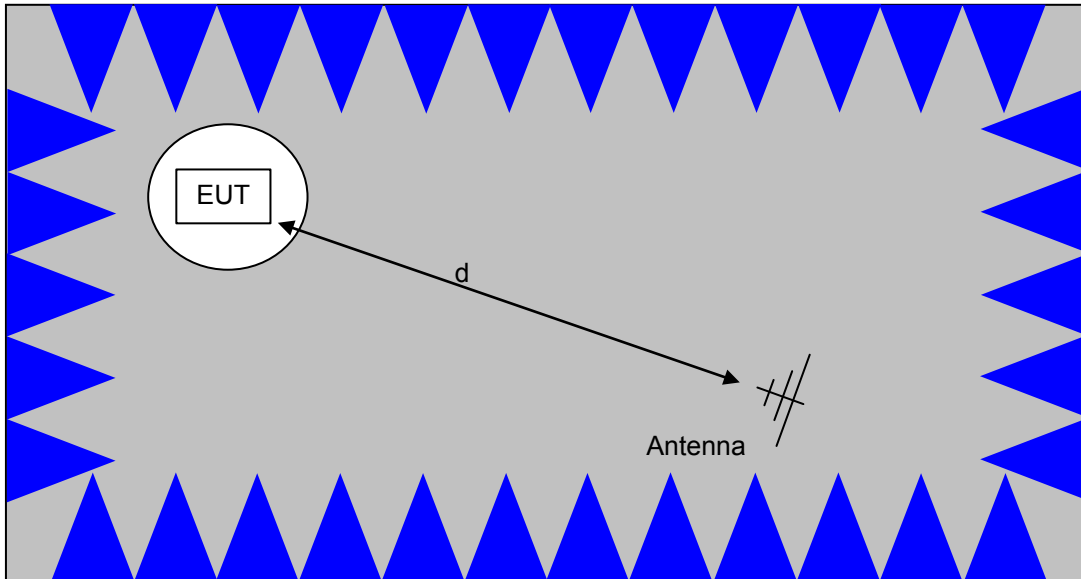

The anechoic materials on the walls and ceiling ensure compliance with the normalized site attenuation requirements of CISPR 16 / CISPR 22 / ANSI C63.4 for an alternate test site at the measurement distances used.

Floor-standing equipment is placed on the floor with insulating supports between the unit and the ground plane.

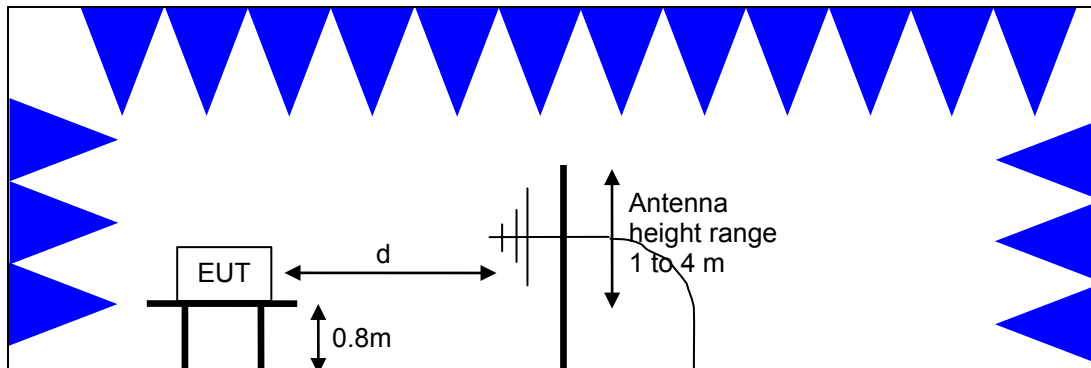

Test Configuration for Radiated Field Strength Measurements
Semi-Anechoic Chamber, Plan and Side Views

CONDUCTED EMISSIONS FROM ANTENNA PORT

Direct measurements of power, bandwidth and power spectral density are performed, where possible, with the antenna port of the EUT connected to either the power meter or spectrum analyzer via a suitable attenuator and/or filter. These are used to ensure that the front end of the measurement instrument is not overloaded by the fundamental transmission.

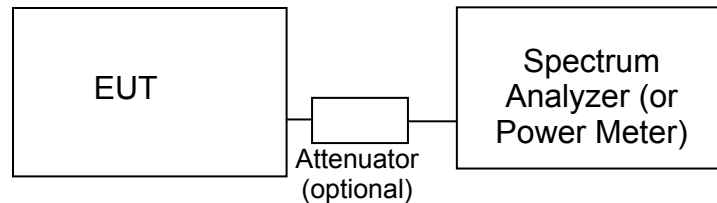
Test Configuration for Antenna Port Measurements

Measurement bandwidths (video and resolution) are set in accordance with the relevant standards and NTS Silicon Valley's test procedures for the type of radio being tested. When power measurements are made using a resolution bandwidth less than the signal bandwidth the power is calculated by summing the power across the signal bandwidth using either the analyzer channel power function or by capturing the trace data and calculating the power using software. In both cases the summed power is corrected to account for the equivalent noise bandwidth (ENBW) of the resolution bandwidth used.

If power averaging is used (typically for certain digital modulation techniques), the EUT is configured to transmit continuously. Power averaging is performed using either the built-in function of the analyzer or, if the analyzer does not feature power averaging, using external software. In both cases the average power is calculated over a number of sweeps (typically 100). When the EUT cannot be configured to continuously transmit then either the analyzer is configured to perform a gated sweep to ensure that the power is averaged over periods that the device is transmitting or power averaging is disabled and a max-hold feature is used.

If a power meter is used to make output power measurements the sensor head type (peak or average) is stated in the test data table.

BANDWIDTH MEASUREMENTS

The 6 dB, 20 dB, 26 dB and/or 99% signal bandwidth are measured using the bandwidths recommended by ANSI C63.10 and RSS GEN.

SPECIFICATION LIMITS AND SAMPLE CALCULATIONS

The limits for conducted emissions are given in units of microvolts, and the limits for radiated emissions are given in units of microvolts per meter at a specified test distance. Data is measured in the logarithmic form of decibels relative to one microvolt, or dB microvolts ($\text{dB}\mu\text{V}$). For radiated emissions, the measured data is converted to the field strength at the antenna in dB microvolts per meter ($\text{dB}\mu\text{V}/\text{m}$). The results are then converted to the linear forms of μV and $\mu\text{V}/\text{m}$ for comparison to published specifications.

For reference, converting the specification limits from linear to decibel form is accomplished by taking the base ten logarithm, then multiplying by 20. These limits in both linear and logarithmic form are as follows:

GENERAL TRANSMITTER RADIATED EMISSIONS SPECIFICATION LIMITS

The table below shows the limits for the spurious emissions from transmitters that fall in restricted bands¹ (with the exception of transmitters operating under FCC Part 15 Subpart D and RSS Gen, the limits for all emissions from a low power device operating under the general rules of RSS 247 and FCC Part 15 Subpart C section 15.209.

Frequency Range (MHz)	Limit ($\mu\text{V}/\text{m}$)	Limit ($\text{dB}\mu\text{V}/\text{m}$ @ 3m)
0.009-0.490	$2400/F_{\text{KHz}}$ @ 300m	$67.6-20*\log_{10}(F_{\text{KHz}})$ @ 300m
0.490-1.705	$24000/F_{\text{KHz}}$ @ 30m	$87.6-20*\log_{10}(F_{\text{KHz}})$ @ 30m
1.705 to 30	30 @ 30m	29.5 @ 30m
30 to 88	100 @ 3m	40 @ 3m
88 to 216	150 @ 3m	43.5 @ 3m
216 to 960	200 @ 3m	46.0 @ 3m
Above 960	500 @ 3m	54.0 @ 3m

RECEIVER RADIATED SPURIOUS EMISSIONS SPECIFICATION LIMITS

The table below shows the limits for the spurious emissions from receivers as detailed in FCC Part 15.109. Note that receivers operating outside of the frequency range 30 MHz – 960 MHz are exempt from the requirements of 15.109.

Frequency Range (MHz)	Limit ($\mu\text{V}/\text{m}$ @ 3m)	Limit ($\text{dB}\mu\text{V}/\text{m}$ @ 3m)
30 to 88	100	40
88 to 216	150	43.5
216 to 960	200	46.0
Above 960	500	54.0

OUTPUT POWER LIMITS – FHSS SYSTEMS

The table below shows the limits for output power based on the number of channels available for the hopping system.

Operating Frequency (MHz)	Number of Channels	Output Power
902 – 928	≥ 50	1 Watt (30 dBm)
902 – 928	25 to 49	0.25 Watts (24 dBm)
2400 – 2483.5	≥ 75	1 Watt (30 dBm)
2400 – 2483.5	< 75	0.125 Watts (21 dBm)
5725 – 5850	75	1 Watt (30 dBm)

¹ The restricted bands are detailed in FCC 15.203, RSS 210 Table 1 and RSS 310 Table 2

TRANSMIT MODE SPURIOUS RADIATED EMISSIONS LIMITS – FHSS and DTS SYSTEMS

The limits for unwanted (spurious) emissions from the transmitter falling in the restricted bands are those specified in the general limits sections of FCC Part 15 and RSS Gen. All other unwanted (spurious) emissions shall be at least 20 dB below the level of the highest in-band signal level (30 dB if the power is measured using the sample detector/power averaging method).

SAMPLE CALCULATIONS - RADIATED EMISSIONS

Receiver readings are compared directly to the specification limit (decibel form). The receiver internally corrects for cable loss, preamplifier gain, and antenna factor. The calculations are in the reverse direction of the actual signal flow, thus cable loss is added and the amplifier gain is subtracted. The Antenna Factor converts the voltage at the antenna coaxial connector to the field strength at the antenna elements.

A distance factor, when used for electric field measurements above 30MHz, is calculated by using the following formula:

$$F_d = 20 * \text{LOG}_{10} (D_m/D_s)$$

where:

$$F_d = \text{Distance Factor in dB}$$

$$D_m = \text{Measurement Distance in meters}$$

$$D_s = \text{Specification Distance in meters}$$

For electric field measurements below 30MHz the extrapolation factor is either determined by making measurements at multiple distances or a theoretical value is calculated using the formula:

$$F_d = 40 * \text{LOG}_{10} (D_m/D_s)$$

Measurement Distance is the distance at which the measurements were taken and Specification Distance is the distance at which the specification limits are based. The antenna factor converts the voltage at the antenna coaxial connector to the field strength at the antenna elements.

The margin of a given emission peak relative to the limit is calculated as follows:

$$R_c = R_r + F_d$$

and

$$M = R_c - L_s$$

where:

$$R_r = \text{Receiver Reading in dB}\mu\text{V/m}$$

$$F_d = \text{Distance Factor in dB}$$

$$R_c = \text{Corrected Reading in dB}\mu\text{V/m}$$

$$L_s = \text{Specification Limit in dB}\mu\text{V/m}$$

$$M = \text{Margin in dB Relative to Spec}$$

Appendix A Test Equipment Calibration Data

<u>Manufacturer</u>	<u>Description</u>	<u>Model</u>	<u>Asset #</u>	<u>Calibrated</u>	<u>Cal Due</u>
Radiated Emissions, 30 - 1,000 MHz, 05-May-15					
Rohde & Schwarz	EMI Test Receiver, 20 Hz-7 GHz	ESIB7	1630	6/21/2014	6/21/2015
Sunol Sciences	Biconilog, 30-3000 MHz	JB3	2237	8/29/2014	8/29/2016
Com-Power	Preamplifier, 1-1000 MHz	PAM-103	2885	10/22/2014	10/22/2015
Radio Antenna Port (Power and Spurious Emissions), 06-May-15					
Agilent Technologies	PSA, Spectrum Analyzer, (installed options, 111, 115, 123, 1DS, B7J, HXY,	E4446A	2139	4/8/2015	4/8/2016
Radiated Spurious Emissions, 30 - 9300 MHz, 09-Jul-15					
Rohde & Schwarz	EMI Test Receiver, 20 Hz-7 GHz	ESIB7	1538	12/20/2014	12/20/2015
Sunol Sciences	Biconilog, 30-3000 MHz	JB3	2197	2/13/2014	2/13/2016
Hewlett Packard	9KHz-1300MHz pre-amp	8447F	2777	3/4/2015	3/5/2016
Radiated Spurious Emissions, 30 - 9,300 MHz, 15-Jul-15					
EMCO	Antenna, Horn, 1-18 GHz	3115	786	12/20/2013	12/20/2015
Rohde & Schwarz	EMI Test Receiver, 20 Hz-7 GHz	ESIB7	1756	6/20/2015	6/20/2016
Hewlett Packard	High Pass filter, 1.5 GHz (Purple System)	P/N 84300-80037	1769	11/14/2014	11/14/2015
Hewlett Packard	Microwave Preamplifier, 1-26.5GHz	8449B	2199	2/20/2015	2/20/2016
Hewlett Packard	SpecAn 9 kHz - 40 GHz, (SA40) Purple	8564E (84125C)	2415	3/7/2015	3/7/2016
Radiated Emissions, 1.2 - 9 GHz, 08-Sep-15					
Hewlett Packard	Microwave Preamplifier, 1-26.5GHz	8449B	785	10/31/2014	10/31/2015
Hewlett Packard	SpecAn 9 kHz - 40 GHz, FT (SA40) Blue	8564E (84125C)	1393	5/2/2015	5/2/2016
EMCO	Antenna, Horn, 1-18 GHz	3115	1561	6/27/2014	6/27/2016
Hewlett Packard	High Pass filter, 1.5 GHz (Purple System)	P/N 84300-80037	1769	11/14/2014	11/14/2015
Radiated Emissions, 30 - 9300 MHz, 09-Sep-15					
EMCO	Antenna, Biconilog Transmitting	3143	180		N/A
Hewlett Packard	Microwave Preamplifier, 1-26.5GHz	8449B	785	10/31/2014	10/31/2015
Hewlett Packard	SpecAn 9 kHz - 40 GHz, FT (SA40) Blue	8564E (84125C)	1393	5/2/2015	5/2/2016
Sunol Sciences	Biconilog, 30-3000 MHz	JB3	1548	9/17/2014	9/17/2016
EMCO	Antenna, Horn, 1-18 GHz	3115	1561	6/27/2014	6/27/2016
Hewlett Packard	High Pass filter, 1.5 GHz (Purple System)	P/N 84300-80037	1769	11/14/2014	11/14/2015
Com-Power	Preamplifier, 30-1000 MHz	PA-103A	2359	12/22/2014	12/22/2015
Rohde & Schwarz	EMI Test Receiver, 20 Hz-40 GHz	ESIB40 (1088.7490.40)	2493	1/23/2015	1/23/2016
Radiated Spurious Emissions, 30 - 1,000 MHz, 14-Sep-15					
Sunol Sciences	Biconilog, 30-3000 MHz	JB3	1548	9/17/2014	9/17/2016



<u>Manufacturer</u>	<u>Description</u>	<u>Model</u>	<u>Asset #</u>	<u>Calibrated</u>	<u>Cal Due</u>
Com-Power	Preamplifier, 30-1000 MHz	PA-103A	2359	12/22/2014	12/22/2015
Rohde & Schwarz	EMI Test Receiver, 20 Hz-40 GHz	ESIB40 (1088.7490.40)	2493	1/23/2015	1/23/2016
Radiated Spurious Emissions, 30 - 9,300 MHz, 03-Nov-15					
NTS	NTS EMI Software (rev 2.10)	N/A	0		N/A
K&L	Tunable band reject filter	3 TNF-800/1000	0		N/A
Hewlett Packard	Microwave Preamplifier, 1-26.5GHz	8449B	870	2/20/2015	2/20/2016
Hewlett Packard	SpecAn 30 Hz -40 GHz, SV (SA40) Red	8564E (84125C)	1148	10/17/2015	10/17/2016
Rohde & Schwarz	EMI Test Receiver, 20 Hz-7 GHz	ESIB7	1538	12/20/2014	12/20/2015
Sunol Sciences	Biconilog, 30-3000 MHz	JB3	1549	6/2/2015	6/2/2017
EMCO	Antenna, Horn, 1-18 GHz	3115	1561	6/27/2014	6/27/2016
Hewlett Packard	9KHz-1300MHz pre-amp	8447F	2777	3/4/2015	3/5/2016
Hewlett Packard	High Pass filter, 1.5 GHz (Blu System)	P/N 84300-80037 (84125C)	1389	5/14/2015	5/14/2016

Appendix B Test Data

T99815 Pages 24 – 46



EMC Test Data

Client:	Topcon Positioning Systems	Job Number:	JD99757
Model:	R2Lite-FH915	T-Log Number:	T99815
		Account Manager:	Deepa Shetty
Contact:	Ferdinand Riodique		-
Emissions Standard(s):	FCC Part 15.247, RSS-247 and AS/NZS 4268	Class:	B
Immunity Standard(s):	-	Environment:	-

EMC Test Data

For The

Topcon Positioning Systems

Model

R2Lite-FH915

Date of Last Test: 11/5/2015



EMC Test Data

Client: Topcon Positioning Systems	Job Number: JD99757
Model: R2Lite-FH915	T-Log Number: T99815
	Project Manager: Deepa Shetty
Contact: Ferdinand Riodique	Project Coordinator: -
Standard: FCC Part 15.247, RSS-247 and AS/NZS 4268	Class: N/A

FCC 15.247 FHSS - Power, Bandwidth and Spurious Emissions

Test Specific Details

Objective: The objective of this test session is to perform final qualification testing of the EUT with respect to the specification listed above.

Date of Test: 11/3/2015	Config. Used: 1
Test Engineer: John Caizzi	Config Change: none
Test Location: Fremont Chamber #7	EUT Voltage: 3.7 VDC battery

General Test Configuration

The EUT and all local support equipment were located on the turntable for radiated spurious emissions testing.

For radiated emissions testing the measurement antenna was located 3 meters from the EUT.

Ambient Conditions:

Temperature:	22 °C
Rel. Humidity:	35 %

Summary of Results

Run #	Test Performed	Limit	Pass / Fail	Result / Margin
1	30 - 9300 MHz, Transmitter Radiated Spurious Emissions	FCC Part 15.209 / 15.247(c)	Pass	50.7 dBµV/m @ 7421.1 MHz (-3.3 dB)

Modifications Made During Testing:

No modifications were made to the EUT during testing

Deviations From The Standard

No deviations were made from the requirements of the standard.

Client: Topcon Positioning Systems	Job Number: JD99757
Model: R2Lite-FH915	T-Log Number: T99815
Contact: Ferdinand Riodique	Project Manager: Deepa Shetty
Standard: FCC Part 15.247, RSS-247 and AS/NZS 4268	Project Coordinator: -
	Class: N/A

Run #1: Transmitter Radiated Spurious Emissions, 30 - 9300 MHz.

Run #1a: Low Channel @ 902.2 MHz

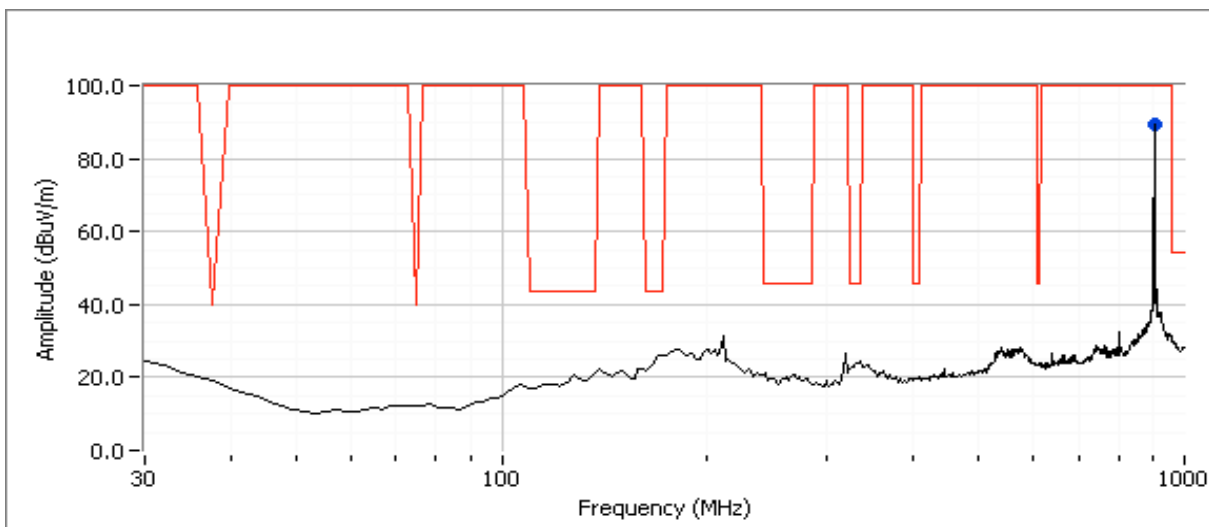

Note: The narrow band tunable band reject filter K&L 3 TNF-800/1000 was used and tuned to suppress fundamental signal.

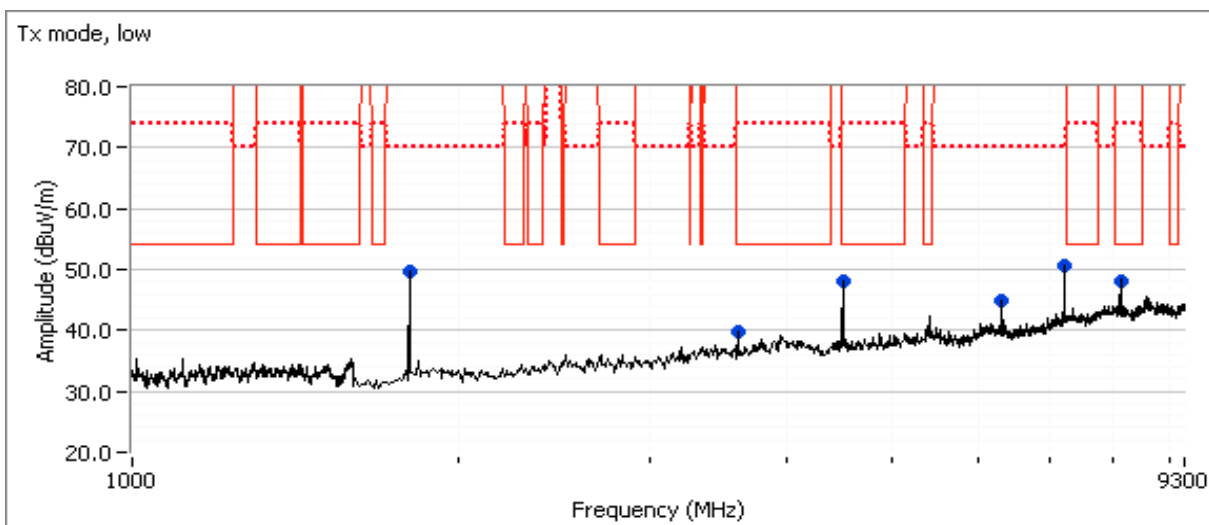



EMC Test Data

Client:	Topcon Positioning Systems	Job Number:	JD99757
Model:	R2Lite-FH915	T-Log Number:	T99815
Contact:	Ferdinand Riodique	Project Manager:	Deepa Shetty
Standard:	FCC Part 15.247, RSS-247 and AS/NZS 4268	Project Coordinator:	-
		Class:	N/A

Other Spurious Emissions

Frequency MHz	Level dB μ V/m	Pol v/h	15.209 / 15.247		Detector Pk/QP/Avg	Azimuth degrees	Height meters	Comments
			Limit	Margin				
3609.000	38.9	V	54.0	-15.1	AVG	262	1.26	
3609.010	46.1	V	74.0	-27.9	PK	262	1.26	
4511.200	48.2	V	54.0	-5.8	AVG	61	2.07	
4511.310	51.9	V	74.0	-22.1	PK	61	2.07	
8120.050	45.5	V	54.0	-8.5	AVG	110	2.46	
8119.600	52.7	V	74.0	-21.3	PK	110	2.46	
1798.000	49.8	H	-	-	Peak	246	1.00	To be measured conducted.
6313.500	44.8	V	-	-	Peak	46	2.50	To be measured conducted.
7215.500	50.6	V	-	-	Peak	40	2.50	To be measured conducted.

Note 1:	For emissions in restricted bands, the limit of 15.209 was used. All other emissions were measured conducted.
Note 2:	Preliminary testing showed that flat-on-the-table orientation was worse case. Final measurements performed with this orientation.

Client: Topcon Positioning Systems	Job Number: JD99757
Model: R2Lite-FH915	T-Log Number: T99815
Contact: Ferdinand Riodique	Project Manager: Deepa Shetty
Standard: FCC Part 15.247, RSS-247 and AS/NZS 4268	Project Coordinator: -
	Class: N/A

Run #1b: Center Channel @ 915 MHz

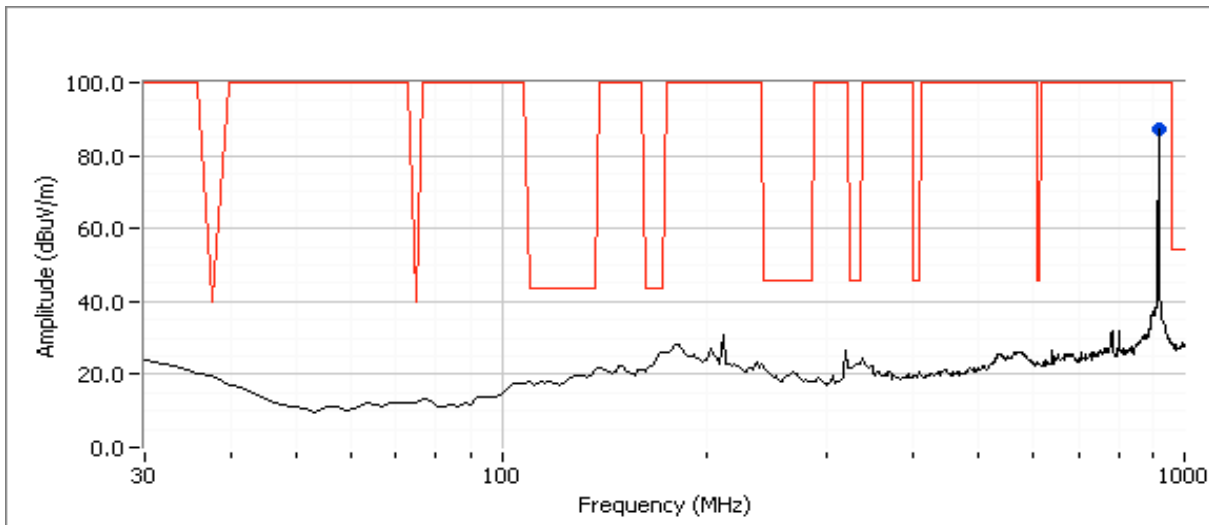

Note: The narrow band tunable band reject filter K&L 3 TNF-800/1000 was used and tuned to suppress fundamental signal.

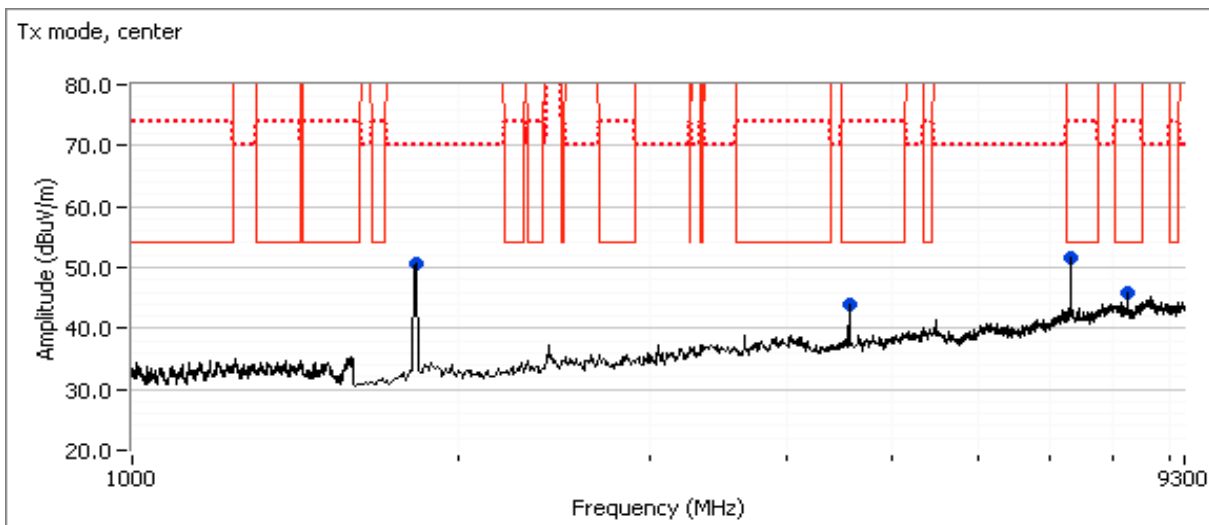



EMC Test Data

Client:	Topcon Positioning Systems	Job Number:	JD99757
Model:	R2Lite-FH915	T-Log Number:	T99815
Contact:	Ferdinand Riodique	Project Manager:	Deepa Shetty
Standard:	FCC Part 15.247, RSS-247 and AS/NZS 4268	Project Coordinator:	-
		Class:	N/A

Frequency MHz	Level dB μ V/m	Pol v/h	15.209 / 15.247		Detector Pk/QP/Avg	Azimuth degrees	Height meters	Comments
			Limit	Margin				
8235.330	42.7	V	54.0	-11.3	AVG	4	1.97	
8235.650	51.0	V	74.0	-23.0	PK	4	1.97	
4575.150	41.1	V	54.0	-12.9	AVG	29	1.99	
4575.120	47.4	V	74.0	-26.6	PK	29	1.99	
7320.320	50.0	V	54.0	-4.0	AVG	35	2.06	
7319.650	54.4	V	74.0	-19.6	PK	35	2.06	
1827.330	50.5	H	-	-	Peak	236	1.50	To be measured conducted.

Note 1:	For emissions in restricted bands, the limit of 15.209 was used. All other emissions were measured conducted.
Note 2:	Preliminary testing showed that flat-on-the-table orientation was worse case. Final measurements performed with this orientation.

Client: Topcon Positioning Systems	Job Number: JD99757
Model: R2Lite-FH915	T-Log Number: T99815
Contact: Ferdinand Riodique	Project Manager: Deepa Shetty
Standard: FCC Part 15.247, RSS-247 and AS/NZS 4268	Project Coordinator: -
	Class: N/A

Run #1c: High Channel @ 927.6 MHz

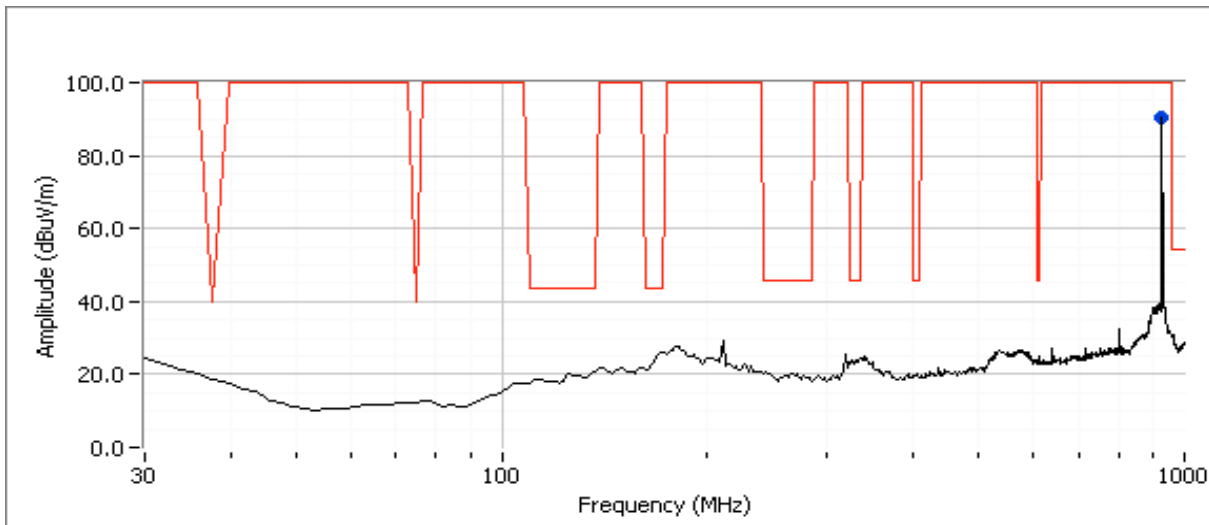

Note: The narrow band tunable band reject filter K&L 3 TNF-800/1000 was used and tuned to suppress fundamental signal.

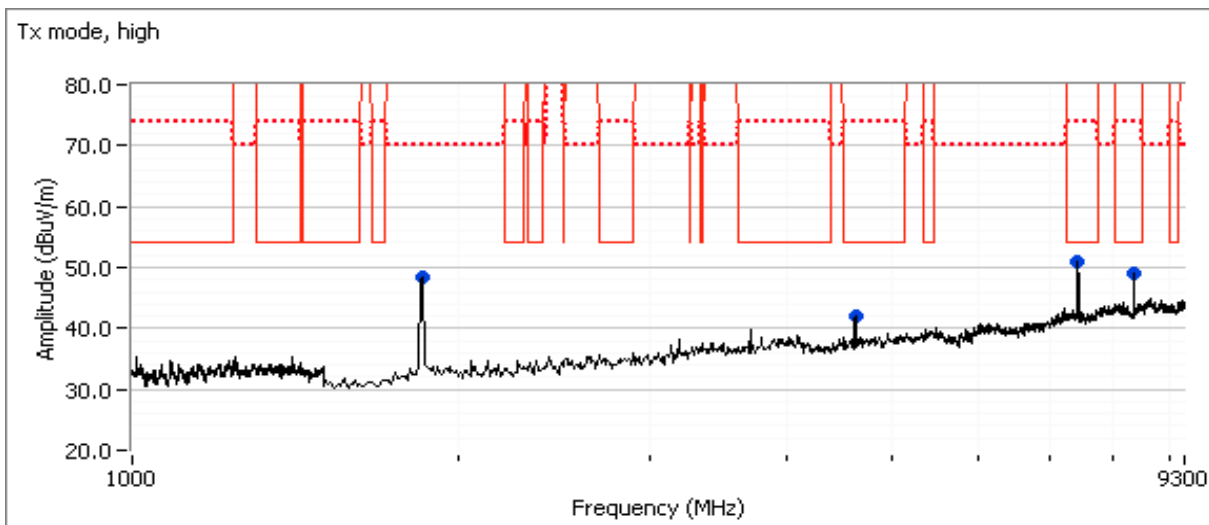

Client: Topcon Positioning Systems	Job Number: JD99757
Model: R2Lite-FH915	T-Log Number: T99815
	Project Manager: Deepa Shetty
Contact: Ferdinand Riodique	Project Coordinator: -
Standard: FCC Part 15.247, RSS-247 and AS/NZS 4268	Class: N/A

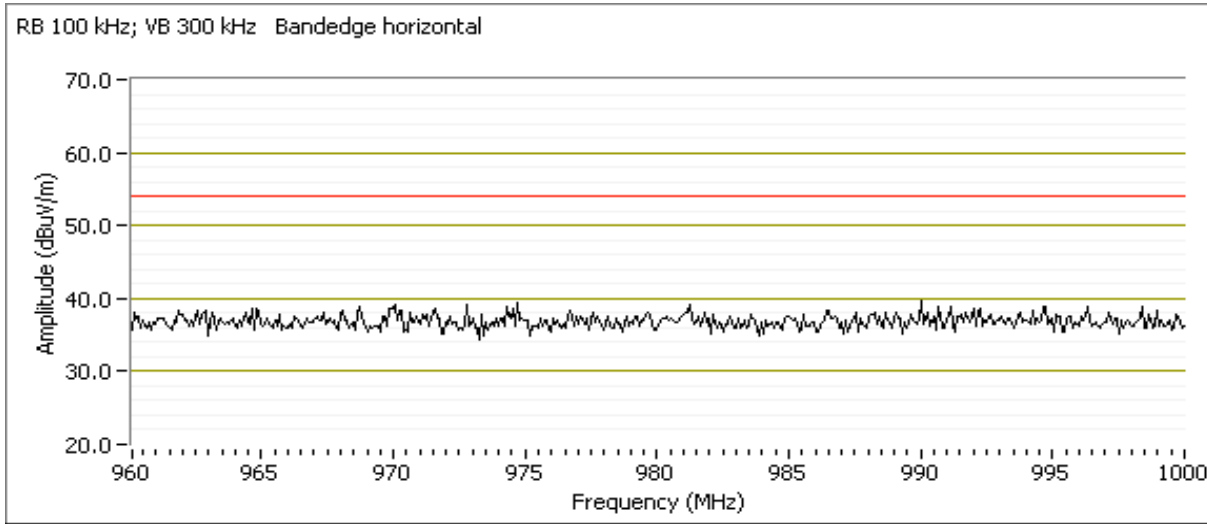

Other Spurious Emissions

Frequency MHz	Level dB μ V/m	Pol v/h	15.209 / 15.247		Detector Pk/QP/Avg	Azimuth degrees	Height meters	Comments
			Limit	Margin				
1852.500	48.4	H	-	-	Peak	224	1.5	To be measured conducted.
4638.120	39.0	V	54.0	-15.0	AVG	31	2.07	
4638.630	46.4	V	74.0	-27.6	PK	31	2.07	
7421.070	50.7	V	54.0	-3.3	AVG	38	2.45	
7420.570	54.8	V	74.0	-19.2	PK	38	2.45	
8348.800	49.7	V	54.0	-4.3	AVG	314	1.99	
8348.000	54.7	V	74.0	-19.3	PK	314	1.99	
988.566	39.9	V	54.0	-14.1	Pk	360	1.00	RB 100 kHz; VB: 300 kHz. Note 2.
970.495	40.1	H	54.0	-13.9	Pk	33	1.47	RB 100 kHz; VB: 300 kHz. Note 2.

Note 1: For emissions in restricted bands, the limit of 15.209 was used. All other emissions were measured conducted.

Note 2: Peak detector vs QP limit.

Note 3: Preliminary testing showed that flat-on-the-table orientation was worse case. Final measurements performed with this orientation.



EMC Test Data

Client: Topcon Positioning Systems	Job Number: JD99757
Model: R2Lite-FH915	T-Log Number: T99815
	Project Manager: Deepa Shetty
Contact: Ferdinand Riodique	Project Coordinator: -
Standard: FCC Part 15.247, RSS-247 and AS/NZS 4268	Class: N/A

FCC 15.247 FHSS - Power, Bandwidth and Spurious Emissions

Test Specific Details

Objective: The objective of this test session is to perform final qualification testing of the EUT with respect to the specification listed above.

Date of Test: 9/9/15 & 9/14/15	Config. Used: 1
Test Engineer: John Caizzi	Config Change: none
Test Location: Fremont Chamber #5	EUT Voltage: Internal battery

General Test Configuration

The EUT and all local support equipment were located on the turntable for radiated spurious emissions testing.

For radiated emissions testing the measurement antenna was located 3 meters from the EUT.

Ambient Conditions:

Temperature: 30 °C
Rel. Humidity: 33 %

Summary of Results

Run #	Test Performed	Limit	Pass / Fail	Result / Margin
2	30 - 2800 MHz, Receiver Radiated Spurious Emissions	FCC Part 15.109	Pass	28.8 dBµV/m @ 800.00 MHz (-17.2 dB)

Modifications Made During Testing:

No modifications were made to the EUT during testing

Deviations From The Standard

No deviations were made from the requirements of the standard.



EMC Test Data

Client: Topcon Positioning Systems	Job Number: JD99757
Model: R2Lite-FH915	T-Log Number: T99815
	Project Manager: Deepa Shetty
Contact: Ferdinand Riodique	Project Coordinator: -
Standard: FCC Part 15.247, RSS-247 and AS/NZS 4268	Class: N/A

Run #2: Receiver Radiated Spurious Emissions, 30 - 2800 MHz.

Run #2a: Low Channel @ 902.2 MHz

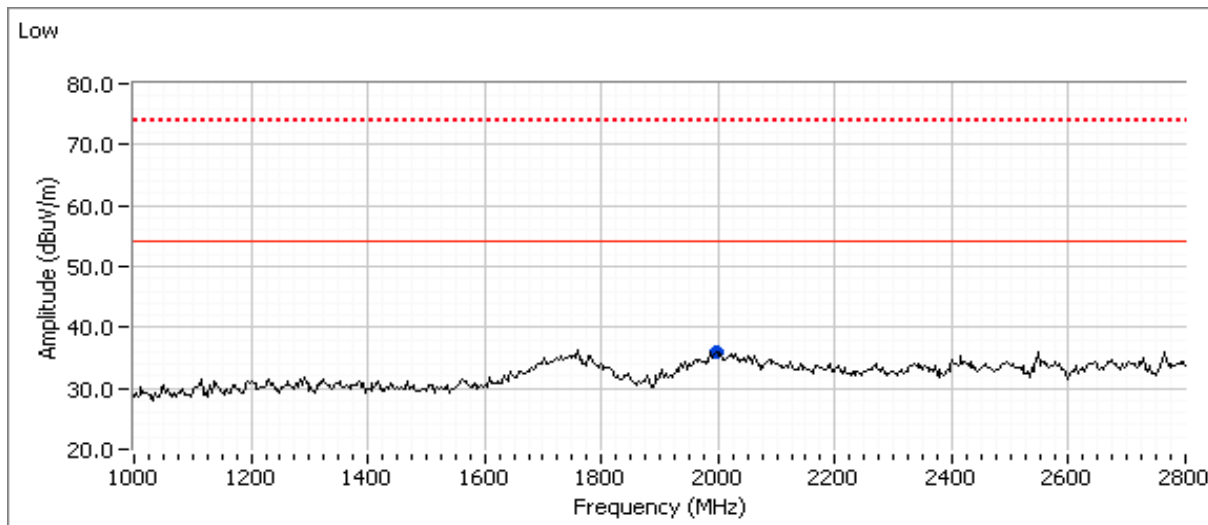
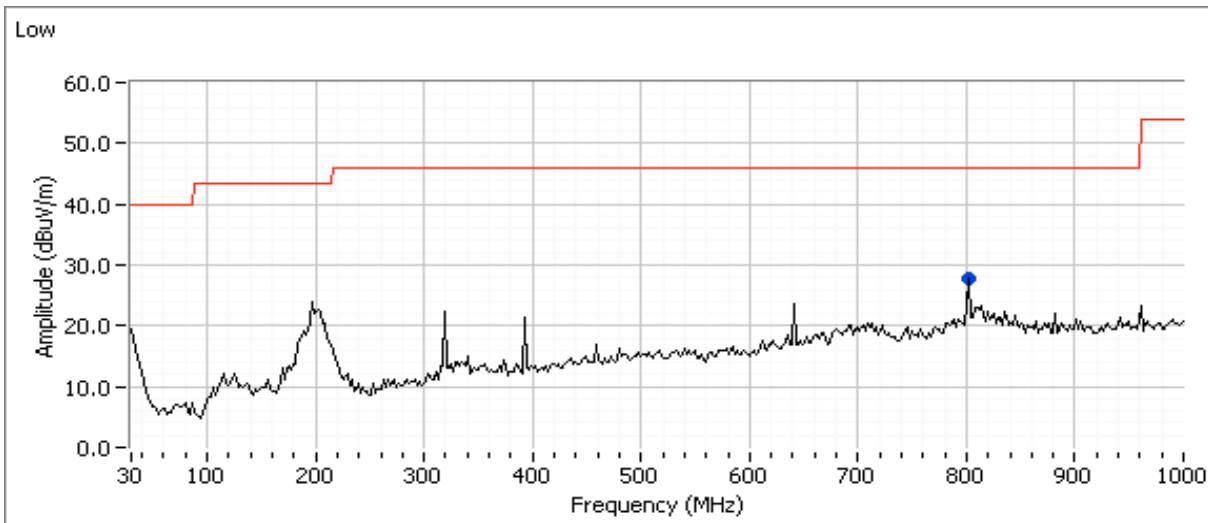

Frequency MHz	Level dB μ V/m	Pol v/h	FCC 15.109		Detector Pk/QP/Avg	Azimuth degrees	Height meters	Comments
			Limit	Margin				
800.003	27.9	H	46.0	-18.1	Peak	325	2.0	
800.003	28.8	H	46.0	-17.2	QP	335	2.00	
1996.000	36.0	H	54.0	-18.0	Peak	107	1.0	



EMC Test Data

Client: Topcon Positioning Systems	Job Number: JD99757
Model: R2Lite-FH915	T-Log Number: T99815
Contact: Ferdinand Riodique	Project Manager: Deepa Shetty
Standard: FCC Part 15.247, RSS-247 and AS/NZS 4268	Project Coordinator: -
	Class: N/A

Run #2b: Center Channel @ 915 MHz

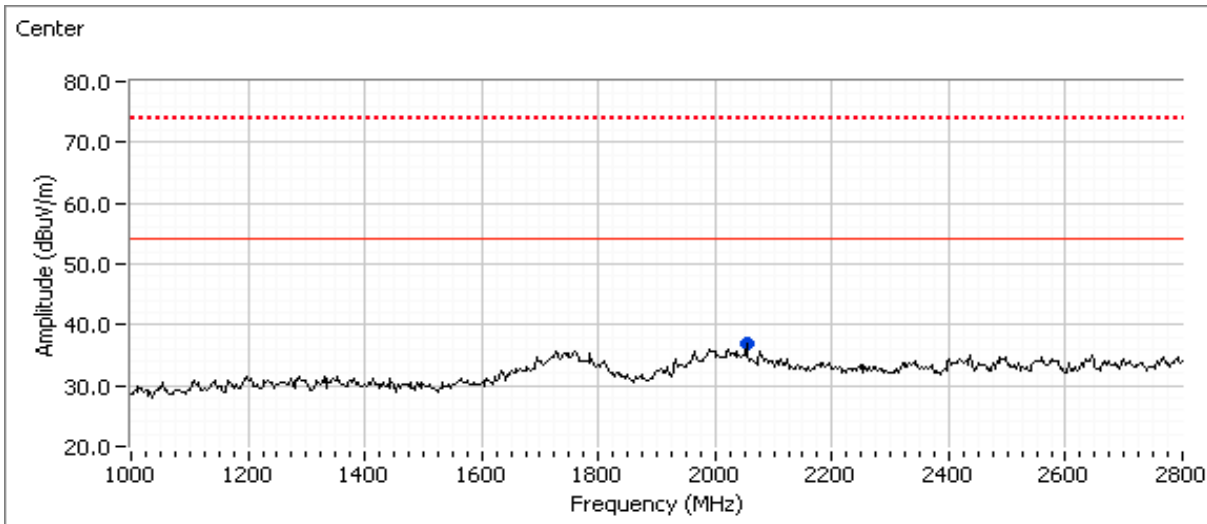
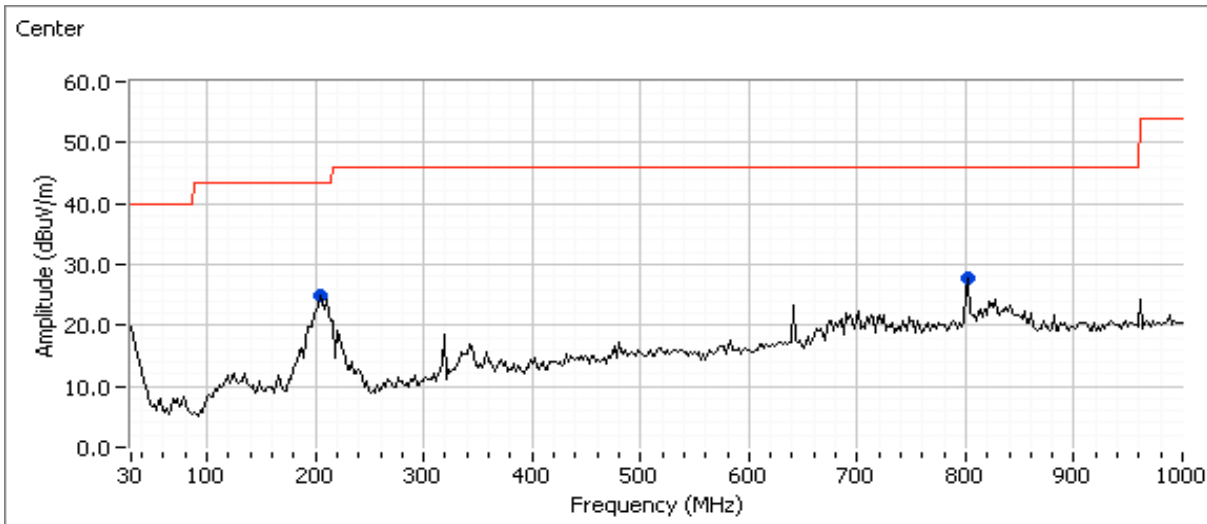

Frequency MHz	Level dB μ V/m	Pol v/h	FCC 15.109		Detector Pk/QP/Avg	Azimuth degrees	Height meters	Comments
			Limit	Margin				
207.969	24.8	H	43.5	-18.7	Peak	283	1.5	
207.969	23.9	H	43.5	-19.6	QP	277	1.72	
800.003	27.9	H	46.0	-18.1	Peak	56	1.0	
800.003	28.4	H	46.0	-17.6	QP	60	1.00	
2053.000	36.8	V	54.0	-17.2	Peak	225	2.0	



EMC Test Data

Client: Topcon Positioning Systems	Job Number: JD99757
Model: R2Lite-FH915	T-Log Number: T99815
Contact: Ferdinand Riodique	Project Manager: Deepa Shetty
Standard: FCC Part 15.247, RSS-247 and AS/NZS 4268	Project Coordinator: -
	Class: N/A

Run #2c: High Channel @ 927.6 MHz

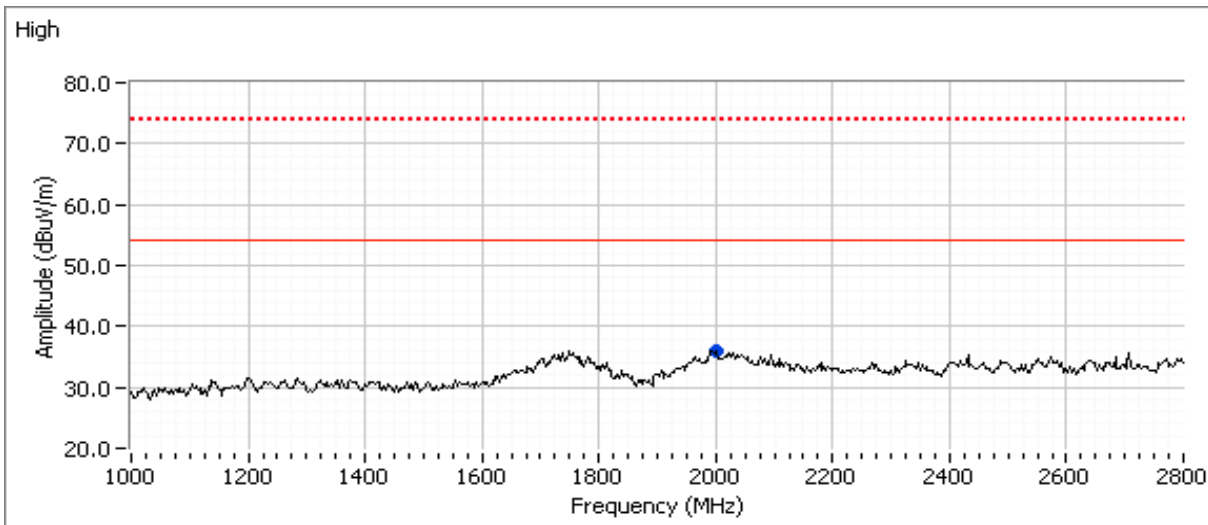
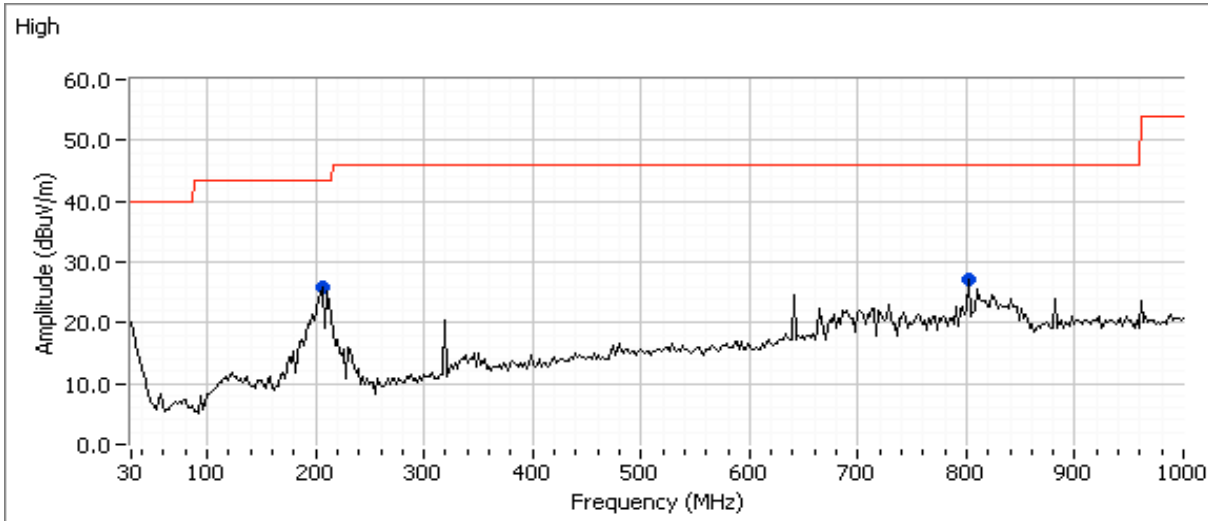

Frequency	Level	Pol	15.109 / RSS GEN		Detector	Azimuth	Height	Comments
MHz	dB μ V/m	v/h	Limit	Margin	Pk/QP/Avg	degrees	meters	
203.031	25.7	H	43.5	-17.8	Peak	269	1.5	
203.031	25.0	H	43.5	-18.5	QP	272	1.39	
800.008	27.0	H	46.0	-19.0	Peak	60	1.0	
800.008	28.4	H	46.0	-17.6	QP	63	1.00	
2002.000	36.0	V	54.0	-18.0	Peak	303	1.0	



EMC Test Data

Client:	Topcon Positioning Systems	Job Number:	JD99757
Model:	R2Lite-FH915	T-Log Number:	T99815
		Project Manager:	Deepa Shetty
Contact:	Ferdinand Riodique	Project Coordinator:	-
Standard:	FCC Part 15.247, RSS-247 and AS/NZS 4268	Class:	N/A

FCC 15.247 FHSS - Power, Bandwidth and Spurious Emissions

Test Specific Details

Objective: The objective of this test session is to perform engineering evaluation testing of the EUT with respect to the specification listed above.

General Test Configuration

The EUT and all local support equipment were located on the turntable for radiated spurious emissions testing.

When measuring the conducted emissions from the EUT's antenna port, the antenna port of the EUT was connected to the spectrum analyzer or power meter via a suitable attenuator to prevent overloading the measurement system. All measurements are corrected to allow for the external attenuators used.

Unless stated otherwise the EUT was operating such that it constantly hopped on either the low, center or high channels.

Ambient Conditions: Temperature: 18-20 °C
 Rel. Humidity: 30-35 %

Summary of Results

Run #	Test Performed	Limit	Pass / Fail	Result / Margin
3	30 - 10,000 MHz - Transmitter Conducted Spurious Emissions	FCC Part 15.247(c)	Pass	All spurious emissions < -20 dBc.
4	Output Power	15.247(b)	Pass	29.8 dBm (2.399 W EIRP)
5	20dB Bandwidth	15.247(a)	Pass	155kHz
5	99% bandwidth	15.247(a)	-	178kHz
5	Channel Occupancy	15.247(a)	Pass	172.2 ms
5	Number of Channels	15.247(a)	Pass	128

Modifications Made During Testing:

No modifications were made to the EUT during testing

Deviations From The Standard

No deviations were made from the requirements of the standard.

Note 1: 30dB pad was used on antenna port.

Client: Topcon Positioning Systems	Job Number: JD99757
Model: R2Lite-FH915	T-Log Number: T99815
Contact: Ferdinand Riodique	Project Manager: Deepa Shetty
Standard: FCC Part 15.247, RSS-247 and AS/NZS 4268	Project Coordinator: -
	Class: N/A

Run #3: Antenna Conducted Spurious Emissions, 30 - 10000 MHz.

Date of Test: 11/05/15

Test Location: Lab 6

Test Engineer: John Caizzi

Refer to plots below. Scans made using RBW=VB=100 KHz with the limit line set at 20dB below the highest in-band signal level with the hopping feature disabled.

Low channel

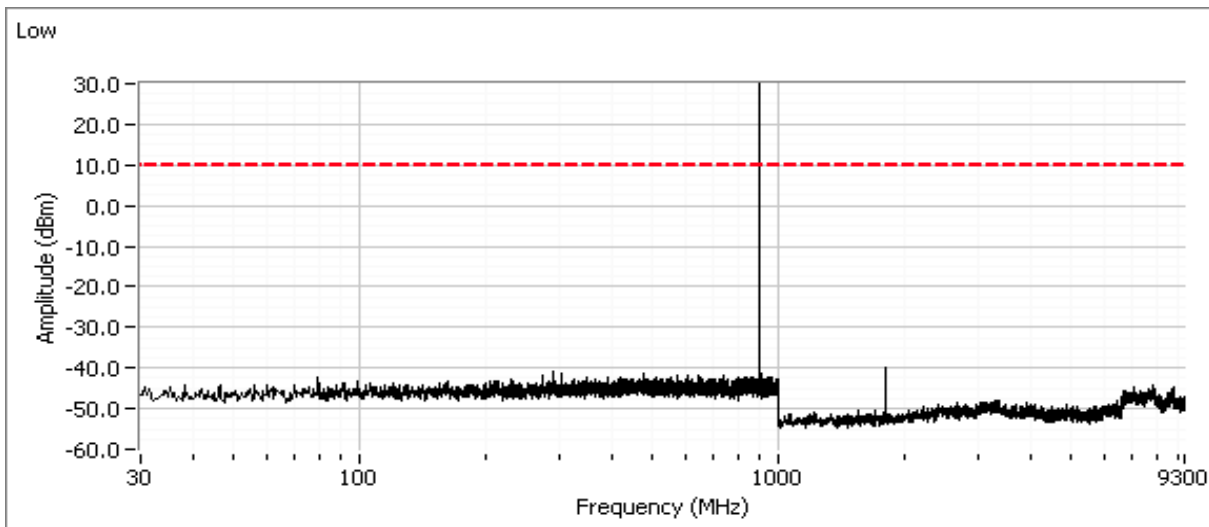

Plot showing -20 dBc at the lower band edge (Tx at 902.2 MHz)

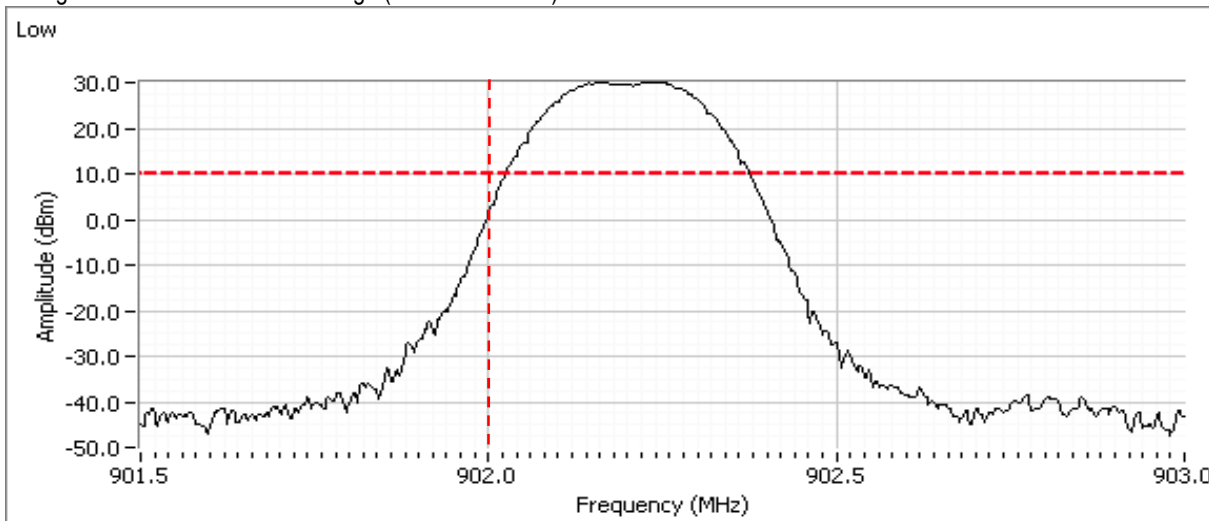

Client: Topcon Positioning Systems	Job Number: JD99757
Model: R2Lite-FH915	T-Log Number: T99815
	Project Manager: Deepa Shetty
Contact: Ferdinand Riodique	Project Coordinator: -
Standard: FCC Part 15.247, RSS-247 and AS/NZS 4268	Class: N/A

Center channel

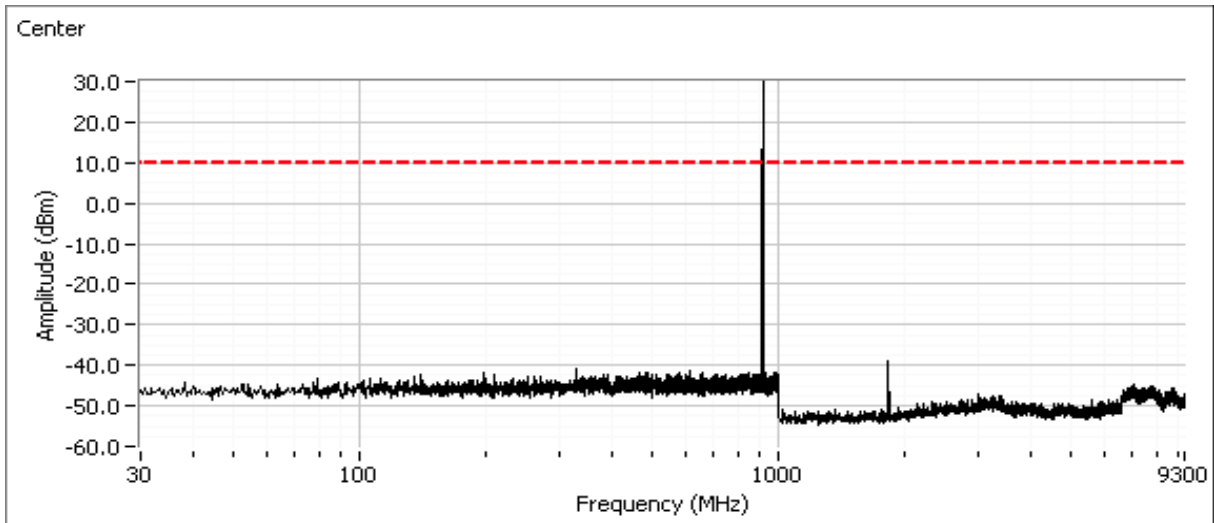

High channel

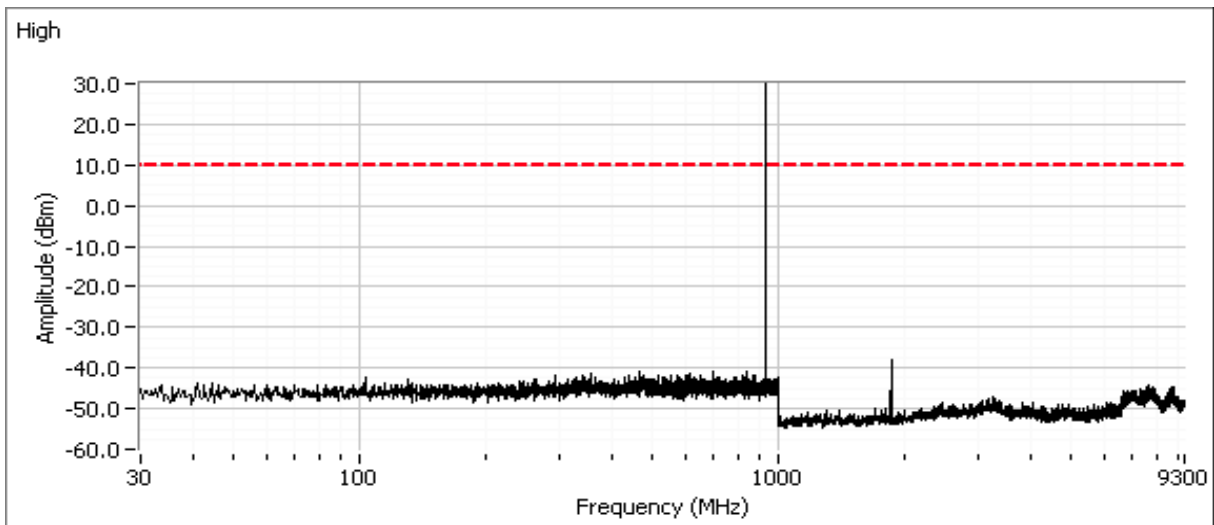

Client: Topcon Positioning Systems	Job Number: JD99757
Model: R2Lite-FH915	T-Log Number: T99815
	Project Manager: Deepa Shetty
Contact: Ferdinand Riodique	Project Coordinator: -
Standard: FCC Part 15.247, RSS-247 and AS/NZS 4268	Class: N/A

Plot showing -20 dBc at the upper band edge (Tx at 927.8 MHz)

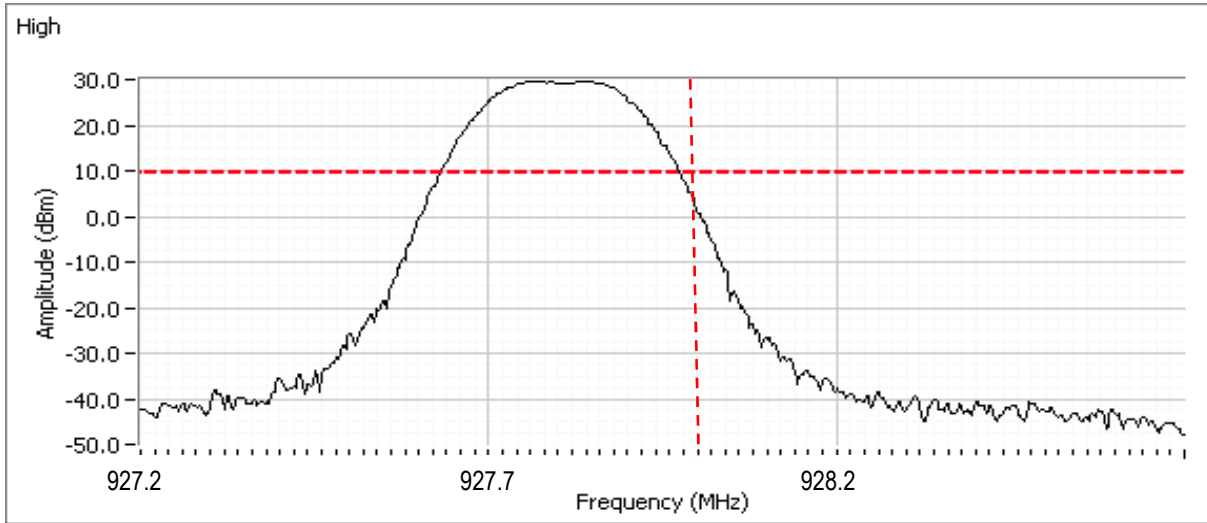

Client: Topcon Positioning Systems	Job Number: JD99757
Model: R2Lite-FH915	T-Log Number: T99815
	Project Manager: Deepa Shetty
Contact: Ferdinand Riodique	Project Coordinator: -
Standard: FCC Part 15.247, RSS-247 and AS/NZS 4268	Class: N/A

Refer to plots below. Scans made using RBW=VB=100 KHz with the limit line set at 20dB below the highest in-band signal level with the **hopping feature enabled** to show compliance with the -20dBc requirement at the allocated band edge. The spectrum analyzer is left in max hold mode until the trace stabilizes.

Plot showing -20 dBc at the lower band edge

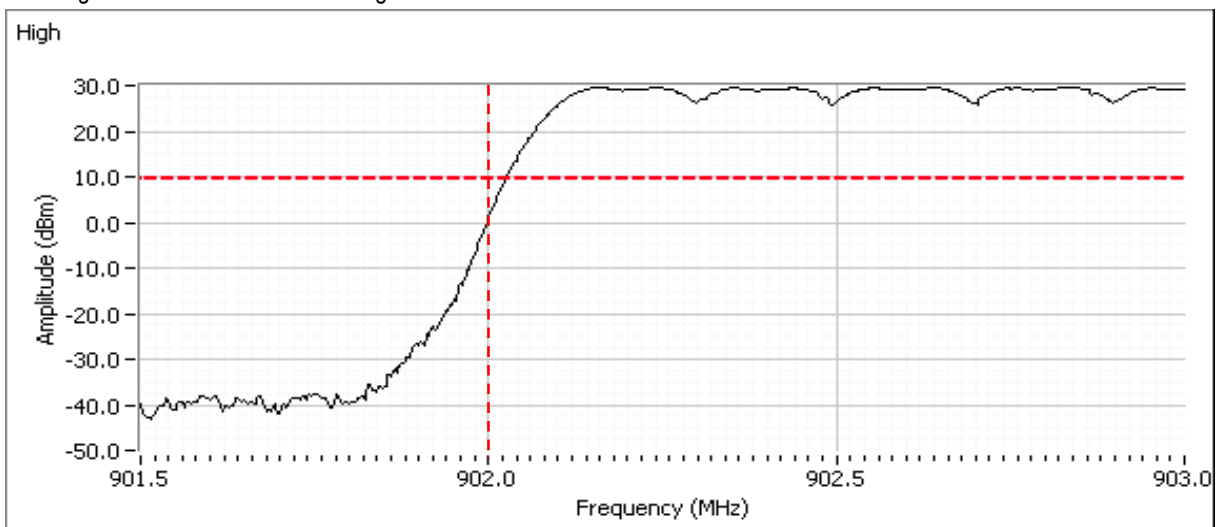

Plot showing -20 dBc at the upper band edge

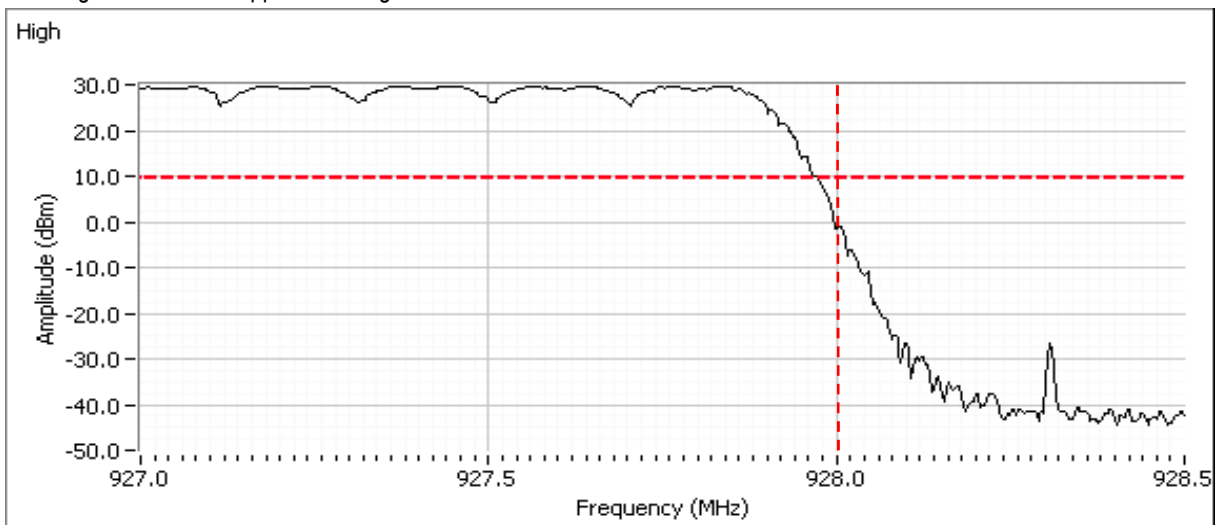



EMC Test Data

Client: Topcon Positioning Systems	Job Number: JD99757
Model: R2Lite-FH915	T-Log Number: T99815
	Project Manager: Deepa Shetty
Contact: Ferdinand Riodique	Project Coordinator: -
Standard: FCC Part 15.247, RSS-247 and AS/NZS 4268	Class: N/A

Run #4: Output Power

Date of Test: 05/06/15

Test Location: Lab 4

Test Engineer: M. Birgani

For frequency hopping systems operating in the 902-928 MHz band: 1 watt for systems employing at least 50 hopping channels; and, 0.25 watts for systems employing less than 50 hopping channels, but at least 25 hopping channels.

Maximum antenna gain: 4.0 dBi

Channel	Frequency (MHz)	Res BW	Output Power (dBm)	Output Power (W)	EIRP (W)
Low	902.2	1MHz	29.8	0.955	2.399
Mid	915.0	1MHz	29.8	0.955	2.399
High	927.8	1MHz	29.8	0.955	2.399

Note 1:

Output power calculated from field strength at 3m based on free space path loss formula $E = \sqrt{(30PG) / d}$, where E is the field strength (V/m), PG is the effective isotropic radiated power (W) and d is the distance (3m). Additional correction to the calculated power is made to account for the difference between the measurement bandwidth and signal bandwidth.

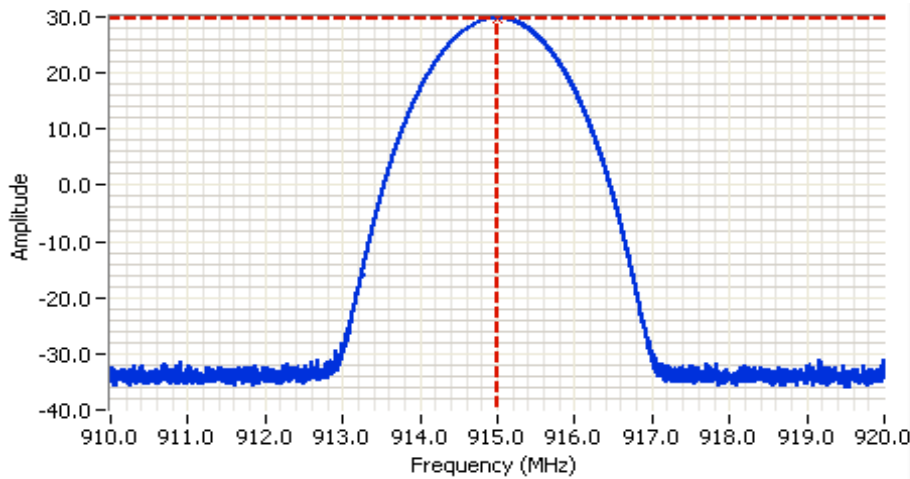

Analyzer Settings

Agilent Technologies, E4446A
 CF: 915.000 MHz
 SPAN: 10.000 MHz
 RB: 1.000 MHz
 VB: 3.000 MHz
 Detector: POS
 Attn: 30 DB
 RL Offset: 20.1 DB
 Sweep Time: 1.0ms
 Ref Lvl: 39.1 DBM

Comments

Power: 29.8 dBm

Cursor 1 914.9990 29.8

0.0000 0.0





EMC Test Data

Client: Topcon Positioning Systems	Job Number: JD99757
Model: R2Lite-FH915	T-Log Number: T99815
Contact: Ferdinand Riodique	Project Manager: Deepa Shetty
Standard: FCC Part 15.247, RSS-247 and AS/NZS 4268	Project Coordinator: -
	Class: N/A

Run #5: Bandwidth, Channel Occupancy, Spacing and Number of Channels

Date of Test: 05/06/15

Test Location: Lab 4

Test Engineer: M. Birgani

Channel	Frequency (MHz)	Resolution Bandwidth	20 dB Bandwidth (kHz)	Resolution Bandwidth	99% Bandwidth (kHz)
Low	902.2	10kHz	155	30kHz	178
Mid	915.0	10kHz	153	30kHz	176
High	927.8	10kHz	154	30kHz	175

Note 1: 20dB bandwidth measured using RB = 10kHz, VB = 30kHz (VB > RB)

Note 2: 99% bandwidth measured using RB = 30kHz, VB = 100kHz (VB >=3RB)

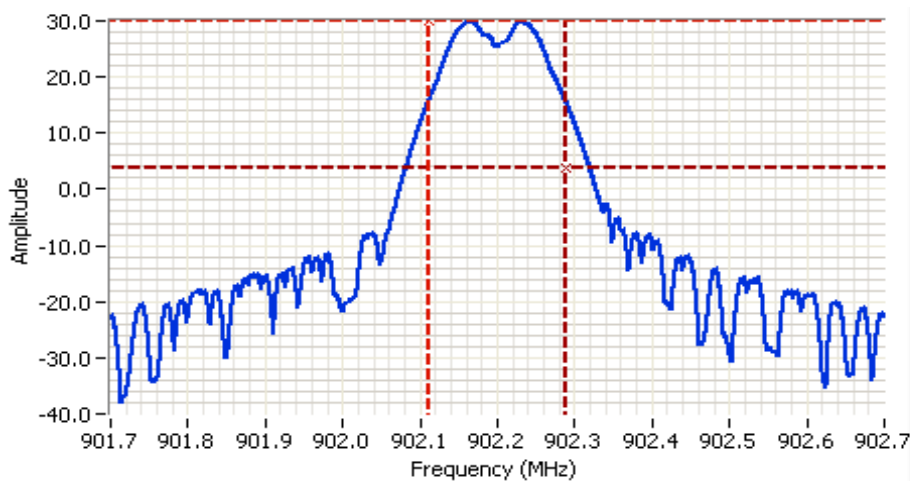

Analyzer Settings

Agilent Technologies, E4446A
 CF: 902.200 MHz
 SPAN: 1.000 MHz
 RB: 30.0 kHz
 VB: 100 kHz
 Detector: POS
 Attn: 30 DB
 RL Offset: 20.1 DB
 Sweep Time: 1.3ms
 Ref Lvl: 39.1 DBM

Comments

99% BW: 178 kHz

Cursor 1	902.1116	29.9	
Cursor 2	902.2894	3.9	

Delta Freq. 178 kHz
 Delta Amplitude 26.0



Client: Topcon Positioning Systems	Job Number: JD99757
Model: R2Lite-FH915	T-Log Number: T99815
Contact: Ferdinand Riodique	Project Manager: Deepa Shetty
Standard: FCC Part 15.247, RSS-247 and AS/NZS 4268	Project Coordinator: -
	Class: N/A

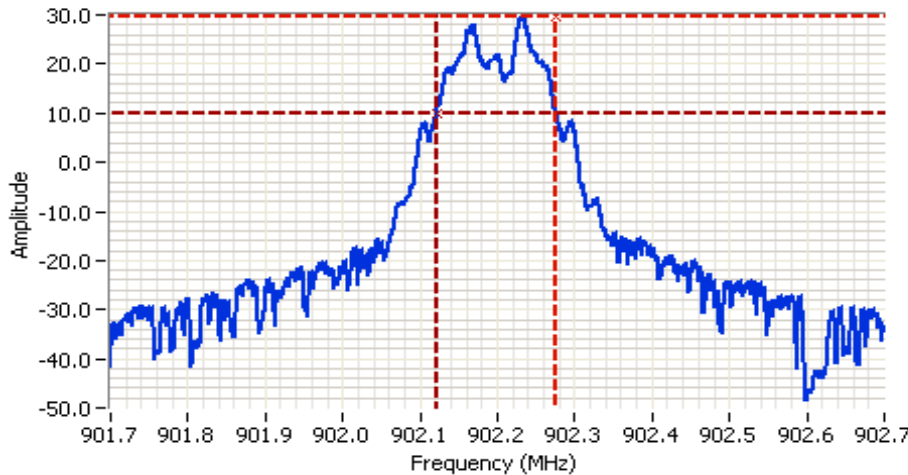

Analyzer Settings

Agilent Technologies, E4446A
 CF: 902.200 MHz
 SPAN: 1.000 MHz
 RB: 10.0 kHz
 VB: 30.0 kHz
 Detector: POS
 Attn: 30 DB
 RL Offset: 20.1 DB
 Sweep Time: 9.7ms
 Ref Lvl: 39.1 DBM

Comments

20dB BW: 155 kHz

Cursor 1	902.2767	29.7		Delta Freq.	155 kHz
Cursor 2	902.1213	9.7		Delta Amplitude	20.0



For frequency hopping systems operating in the **902-928 MHz** band:

If the 20 dB bandwidth of the hopping channel is less than 250 kHz, the system shall use at least 50 hopping frequencies and the average time of occupancy on any frequency shall not be greater than 0.4 seconds within a 20 second period.

The channel dwell time is calculated from the transmit time on a channel multiplied by the number of times a channel could be used in the 20 second period (i.e. 20s divided by the time between successive hops, rounded up to the closest integer), unless the time between successive hops exceeds 20s in which case the channel dwell time is the transmit time on a channel.

Maximum 20dB bandwidth:	<u>155 kHz</u>	Pass
Channel spacing:	<u>200 kHz</u>	Pass
Transmission time per hop:	<u>86.1 ms</u>	
The time between successive hops on a channel:	<u>12188 ms</u>	
Number of channels (N):	<u>128</u>	Pass
Channel dwell time in 20 seconds:	<u>172.2 ms</u>	Pass

-0.655015

Client: Topcon Positioning Systems	Job Number: JD99757
Model: R2Lite-FH915	T-Log Number: T99815
Contact: Ferdinand Riodique	Project Manager: Deepa Shetty
Standard: FCC Part 15.247, RSS-247 and AS/NZS 4268	Project Coordinator: -
	Class: N/A

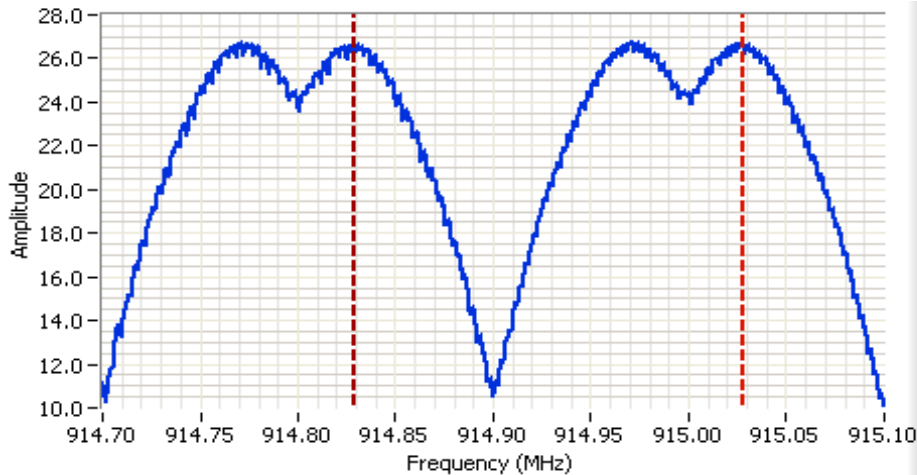

Analyzer Settings
 Agilent Technologies, E4446A
 CF: 914.900 MHz
 SPAN: 400 kHz
 RB: 30.0 kHz
 VB: 100 kHz
 Detector: POS
 Attn: 30 DB
 RL Offset: 20.1 DB
 Sweep Time: 1.0ms
 Ref Lvl: 39.1 DBM

Comments
 Channel Spacing: 199 kHz

Cursor 1 915.0278 30.0  Delta Freq. 199 kHz

Cursor 2 914.8289 30.0  Delta Amplitude 0.0

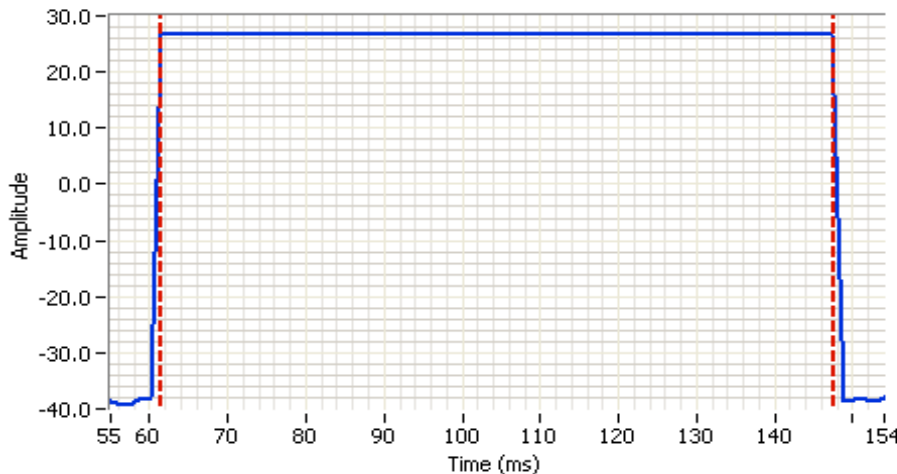

Analyzer Settings
 Agilent Technologies, E4446A
 CF: 915.000 MHz
 SPAN: 0.000 MHz
 RB: 300 kHz
 VB: 300 kHz
 Detector: POS
 Attn: 30 DB
 RL Offset: 20.1 DB
 Sweep Time: 1.0s
 Ref Lvl: 39.1 DBM

Comments
 Transmission time per hop:
 86.1 ms

Cursor 1 61.4323 35.0  Delta Time (ms) 86.1

Cursor 2 147.5260 35.0  Delta Amplitude 0.0



Client: Topcon Positioning Systems	Job Number: JD99757
Model: R2Lite-FH915	T-Log Number: T99815
Contact: Ferdinand Riodique	Project Manager: Deepa Shetty
Standard: FCC Part 15.247, RSS-247 and AS/NZS 4268	Project Coordinator: -
	Class: N/A

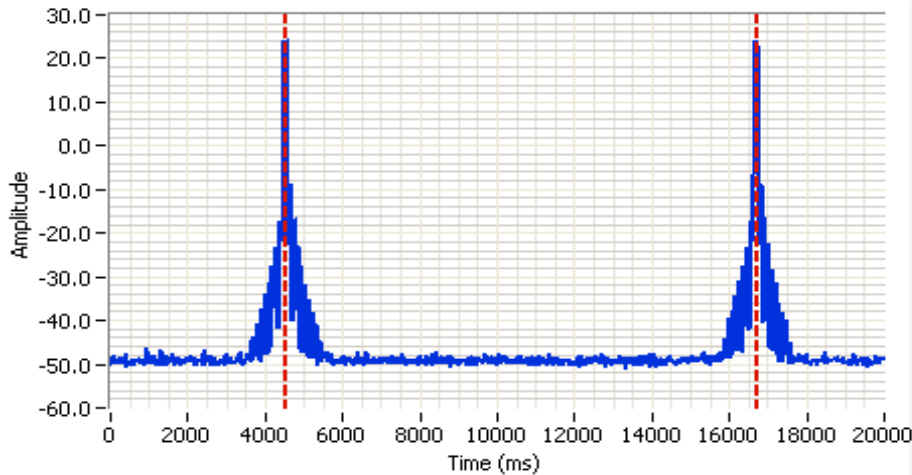

Analyzer Settings
 Agilent Technologies, E4446A
 CF: 915.000 MHz
 SPAN: 0.000 MHz
 RB: 30.0 kHz
 VB: 100 kHz
 Detector: POS
 Attn: 30 DB
 RL Offset: 20.1 DB
 Sweep Time: 20.0s
 Ref Lvl: 39.1 DBM

Comments
 Time between successive hops over 20s intervals

Cursor 1: 4531.2606 35.0
 Cursor 2: 16718.7892 35.0
 Delta Time (ms): 12187.5
 Delta Amplitude: 0.0

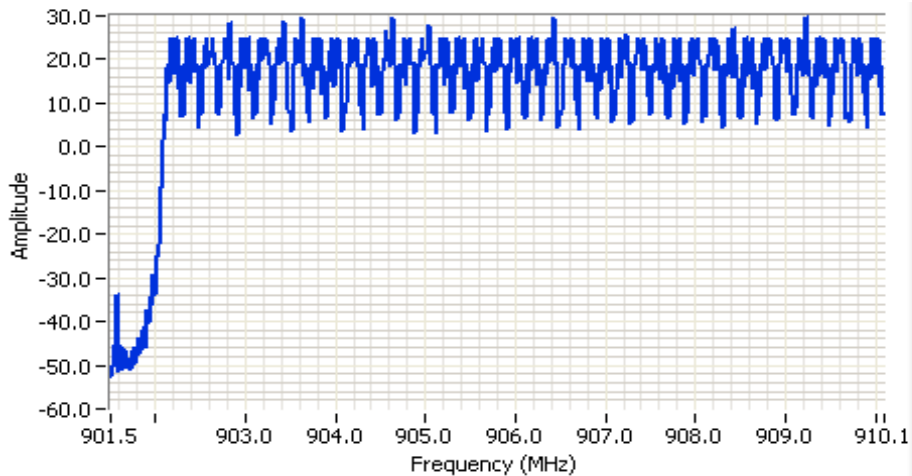

Analyzer Settings
 Agilent Technologies, E4446A
 CF: 905.800 MHz
 SPAN: 8.600 MHz
 RB: 10.0 kHz
 VB: 1.000 MHz
 Detector: POS
 Attn: 30 DB
 RL Offset: 20.1 DB
 Sweep Time: 79.1ms
 Ref Lvl: 39.1 DBM

Comments
 Number of Channels
 Part 1: 40 channels

Cursor 1: 910.2344 41.5
 0.0000 0.0





EMC Test Data

Client: Topcon Positioning Systems	Job Number: JD99757
Model: R2Lite-FH915	T-Log Number: T99815
Contact: Ferdinand Riodique	Project Manager: Deepa Shetty
Standard: FCC Part 15.247, RSS-247 and AS/NZS 4268	Project Coordinator: -
	Class: N/A

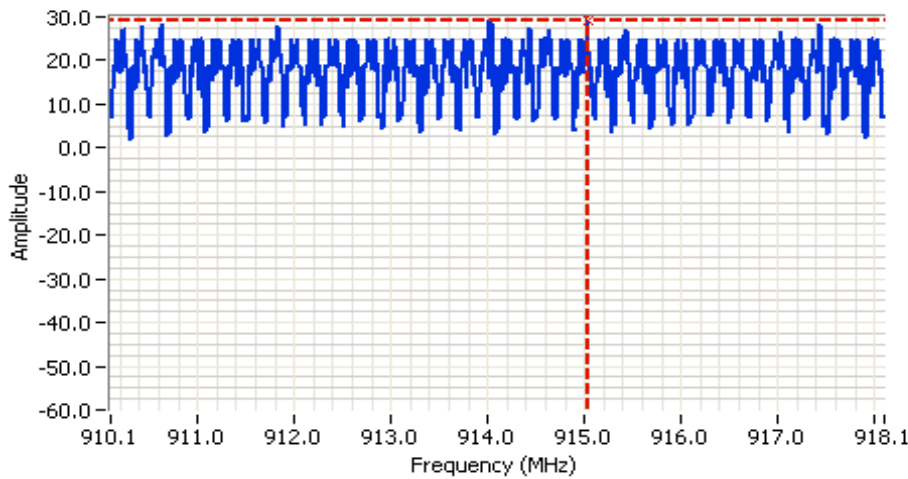

Analyzer Settings
 Agilent Technologies, E4446A
 CF: 914.100 MHz
 SPAN: 8.000 MHz
 RB: 10.0 kHz
 VB: 1.000 MHz
 Detector: POS
 Attn: 30 DB
 RL Offset: 20.1 DB
 Sweep Time: 73.6ms
 Ref Lvl: 39.1 DBM

Comments
 Number of Channels
 Part 2: 40 channels

Cursor 1 915.0328 29.2 [Icons]
 0.0000 0.0 [Icons]

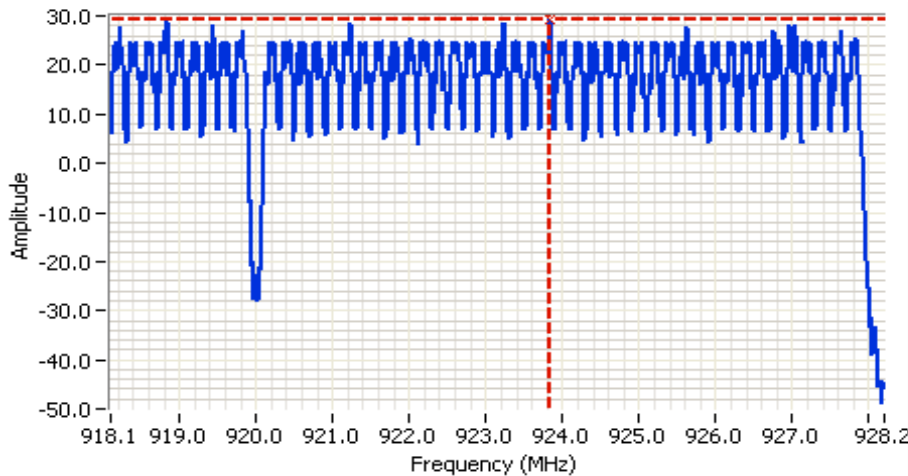

Analyzer Settings
 Agilent Technologies, E4446A
 CF: 923.150 MHz
 SPAN: 10.100 MHz
 RB: 10.0 kHz
 VB: 1.000 MHz
 Detector: POS
 Attn: 30 DB
 RL Offset: 20.1 DB
 Sweep Time: 92.9ms
 Ref Lvl: 39.1 DBM

Comments
 Number of Channels
 Part 3: 48 channels
 Total: 128 channels

Cursor 1 923.8363 29.1 [Icons]
 0.0000 0.0 [Icons]



End of Report

This page is intentionally blank and marks the last page of this test report.