



RADIO TEST REPORT

Test Report No. : 11333790S-A-R3

Applicant : Telepower Inc.
Type of Equipment : Zigbee Module
Model No. : TPZMT-01T
FCC ID : WQYTPZM01
Test regulation : FCC Part 15 Subpart C: 2018
Test Result : Complied

1. This test report shall not be reproduced in full or partial, without the written approval of UL Japan, Inc.
2. The results in this report apply only to the sample tested.
3. This sample tested is in compliance with the above regulation.
4. The test results in this report are traceable to the national or international standards.
5. The opinions and the interpretations to the result of the description in this report are outside scopes where UL Japan has been accredited.
6. This test report covers Radio technical requirements. It does not cover administrative issues such as Manual or non-Radio test related Requirements. (if applicable)
7. This report is a revised version of 11333790S-A-R2. 11333790S-A-R2 is replaced with this report.

Date of test: June 28 to July 8, 2016

Representative test engineer:

Kazutaka Takeyama
Engineer
Consumer Technology Division

Approved by:

Shinichi Takano
Engineer
Consumer Technology Division



- The testing in which "Non-accreditation" is displayed is outside the accreditation scopes in UL Japan.
 There is no testing item of "Non-accreditation".

UL Japan, Inc.
Shonan EMC Lab.

1-22-3 Megumigaoka, Hiratsuka-shi, Kanagawa-ken, 259-1220 JAPAN
Telephone : +81 463 50 6400
Facsimile : +81 463 50 6401

13-EM-F0429

CONTENTS	PAGE
SECTION 1: Customer information.....	4
SECTION 2: Equipment under test (E.U.T.).....	4
SECTION 3: Test specification, procedures & results.....	5
SECTION 4: Operation of E.U.T. during testing.....	8
SECTION 5: Conducted Emission.....	9
SECTION 6: Radiated Spurious Emission	10
SECTION 7: Antenna Terminal Conducted Tests.....	12
APPENDIX 1: Test data	13
Conducted Emission	13
6 dB Bandwidth and 99 % Occupied Bandwidth.....	16
Maximum Peak Output Power	19
Average Output Power	20
Burst rate confirmation	21
Radiated Spurious Emission	22
Conducted Spurious Emission	28
Power Density	31
APPENDIX 2: Test instruments	33
APPENDIX 3: Photographs of test setup	34
Conducted Emission	34
Radiated Spurious Emission	35
Worst Case Position	36

SECTION 1: Customer information

Company Name : Telepower Inc.
Address : 2-11-9 #3F, Minamiikebukuro, Toshima-ku, Tokyo, 171-0022, Japan
Telephone Number : +81-3-6907-8511
Facsimile Number : +81-3-6907-8512
Contact Person : Hiroshi Ohuchi

SECTION 2: Equipment under test (E.U.T.)

2.1 Identification of E.U.T.

Type of Equipment : Zigbee Module
Model No. : TPZMT-01T
Serial No. : Refer to Section 4, Clause 4.2
Rating : DC 2.7 V - 3.4 V
Receipt Date of Sample : June 28, 2016
Country of Mass-production : Japan
Condition of EUT : Production prototype
(Not for Sale: This sample is equivalent to mass-produced items.)
Modification of EUT : No Modification by the test lab.

2.2 Product Description

Model: TPZMT-01T (referred to as the EUT in this report) is a Zigbee Module.

Radio Specification

Radio Type : Transceiver
Frequency of Operation : 2405 MHz - 2480 MHz
Modulation : O-QPSK, DSSS
Antenna type : Chip
Antenna Gain : 2.5 dBi
Clock frequency (Maximum) : 24 MHz

SECTION 3: Test specification, procedures & results

3.1 Test Specification

Test Specification : FCC Part 15 Subpart C
FCC Part 15 final revised on March 12, 2018 and effective April 11, 2018

Title : FCC 47CFR Part15 Radio Frequency Device Subpart C Intentional Radiators
Section 15.207 Conducted limits
Section 15.247 Operation within the bands 902-928MHz,
2400-2483.5MHz, and 5725-5850MHz

All the revisions made after testing date do not affect the test specification applied to the EUT.

3.2 Procedures and results

Item	Test Procedure	Specification	Worst margin	Results	Remarks
Conducted Emission	FCC: ANSI C63.10-2013 6. Standard test methods IC: RSS-Gen 8.8	FCC: Section 15.207 IC: RSS-Gen 8.8	28.2 dB, 0.50250 MHz, L1 Tx 2480 MHz, QP	Complied	-
6dB Bandwidth	FCC: KDB 558074 D01 DTS Meas Guidance v04 IC: -	FCC: Section 15.247(a)(2) IC: RSS-247 5.2(a)	See data.	Complied	Conducted
Maximum Peak Output Power	FCC: KDB 558074 D01 DTS Meas Guidance v04 IC: RSS-Gen 6.12	FCC: Section 15.247(b)(3) IC: RSS-247 5.4(d)		Complied	Conducted
Power Density	FCC: KDB 558074 D01 DTS Meas Guidance v04 IC: -	FCC: Section 15.247(e) IC: RSS-247 5.2(b)		Complied	Conducted
Spurious Emission Restricted Band Edges	FCC: KDB 558074 D01 DTS Meas Guidance v04 IC: RSS-Gen 6.13	FCC: Section15.247(d) IC: RSS-247 5.5 RSS-Gen 8.9 RSS-Gen 8.10	0.5 dB 4810.00 MHz, Vertical Tx 2405 MHz, AV	Complied	Conducted (below 30 MHz)/ Radiated (above 30 MHz) *1)
Note: UL Japan, Inc.'s EMI Work Procedures No. 13-EM-W0420 and 13-EM-W0422. *1) Radiated test was selected over 30 MHz based on section 15.247(d) and KDB 558074 D01 DTS Meas Guidance v04 12.2.7.					

* In case any questions arise about test procedure, ANSI C63.10: 2013 is also referred.

FCC Part 15.31 (e)

The RF Module has its own regulator. The RF Module is constantly provided voltage (DC 1.8 V) through the regulator regardless of input voltage. Therefore, this EUT complies with the requirement.

FCC Part 15.203/212 Antenna requirement

It is impossible for end users to replace the antenna, because it is soldered on the circuit board. Therefore, the equipment complies with the antenna requirement.

3.3 Addition to standard

Item	Test Procedure	Specification	Worst margin	Results	Remarks
99% Occupied Bandwidth	IC: RSS-Gen 6.6	IC: -	N/A	-	Conducted

Other than above, no addition, exclusion nor deviation has been made from the standard.

3.4 Uncertainty

The following uncertainties have been calculated to provide a confidence level of 95 % using a coverage factor $k = 2$.
Shonan EMC Lab.

Item	Frequency range	Uncertainty (+/-)			
		No. 1 SAC / SR	No. 2 SAC / SR	No. 3 SAC / SR	No. 4 SAC / SR
Conducted emission (AC Mains) LISN	150 kHz-30 MHz	2.1 dB	2.1 dB	2.6 dB	2.2 dB
Radiated emission (Measurement distance: 3 m)	9 kHz-30 MHz	2.7 dB	2.7 dB	3.1 dB	-
	30 MHz-300 MHz	4.4 dB	4.4 dB	4.6 dB	-
	300 MHz-1 GHz	5.6 dB	5.5 dB	5.3 dB	-
	1 GHz-13 GHz	5.2 dB	5.2 dB	5.2 dB	-
Radiated emission (Measurement distance: 1 m)	13 GHz-18 GHz	4.9 dB	4.9 dB	4.9 dB	-
	18 GHz-40 GHz	4.9 dB	4.9 dB	4.9 dB	-

SAC=Semi-Anechoic Chamber

SR= Shielded Room is applied besides radiated emission

Antenna terminal test	Uncertainty (+/-)
Power Measurement above 1 GHz (Average Detector)_SPM-06	0.76 dB
Power Measurement above 1 GHz (Peak Detector)_SPM-06	0.79 dB
Power Measurement above 1 GHz (Average Detector)_SPM-07	0.74 dB
Power Measurement above 1 GHz (Peak Detector)_SPM-07	1.08 dB
Spurious emission (Conducted) below 1GHz	1.5 dB
Spurious emission (Conducted) 1 GHz-3 GHz	1.7 dB
Spurious emission (Conducted) 3 GHz-18 GHz	2.4 dB
Spurious emission (Conducted) 18 GHz-26.5 GHz	2.5 dB
Spurious emission (Conducted) 26.5 GHz-40 GHz	2.5 dB
Bandwidth Measurement	0.66 %
Duty cycle and Time Measurement	0.012 %

Conducted Emission test

The data listed in this test report has enough margin, more than the site margin.

Radiated emission test

The data listed in this report meets the limits unless the uncertainty is taken into consideration.

3.5 Test Location

UL Japan, Inc. Shonan EMC Lab.
 1-22-3, Megumigaoka, Hiratsuka-shi, Kanagawa-ken 259-1220 JAPAN
 Telephone: +81 463 50 6400, Facsimile: +81 463 50 6401
 JAB Accreditation No. RTL02610
 FCC Test Firm Registration Number: 839876

Test site	IC Registration Number	Width x Depth x Height (m)	Size of reference ground plane (m) / horizontal conducting plane	Maximum measurement distance
No.1 Semi-anechoic chamber	2973D-1	20.6 x 11.3 x 7.65	20.6 x 11.3	10 m
No.2 Semi-anechoic chamber	2973D-2	20.6 x 11.3 x 7.65	20.6 x 11.3	10 m
No.3 Semi-anechoic chamber	2973D-3	12.7 x 7.7 x 5.35	12.7 x 7.7	5 m
No.4 Semi-anechoic chamber	-	8.1 x 5.1 x 3.55	8.1 x 5.1	-
No.1 Shielded room	-	6.8 x 4.1 x 2.7	6.8 x 4.1	-
No.2 Shielded room	-	6.8 x 4.1 x 2.7	6.8 x 4.1	-
No.3 Shielded room	-	6.3 x 4.7 x 2.7	6.3 x 4.7	-
No.4 Shielded room	-	4.4 x 4.7 x 2.7	4.4 x 4.7	-
No.5 Shielded room	-	7.8 x 6.4 x 2.7	7.8 x 6.4	-
No.6 Shielded room	-	7.8 x 6.4 x 2.7	7.8 x 6.4	-
No.8 shielded room	-	3.45 x 5.5 x 2.4	3.45 x 5.5	-
No.1 Measurement room	-	2.55 x 4.1 x 2.5	-	-

3.6 Test data, Test instruments, and Test set up

Refer to APPENDIX.

SECTION 4: Operation of E.U.T. during testing

4.1 Operating Mode(s)

Mode	Remarks*
Transmitting (Tx) 2405 MHz 2440 MHz 2480 MHz	PRBS9
*Transmitting duty was 100 % on all tests. *Power of the EUT was set by the software as follows; Power settings: Fixed Software: TeraTerm Ver.4.68 *This setting of software is the worst case. Any conditions under the normal use do not exceed the condition of setting. In addition, end users cannot change the settings of the output power of the product.	

4.2 Configuration and peripherals

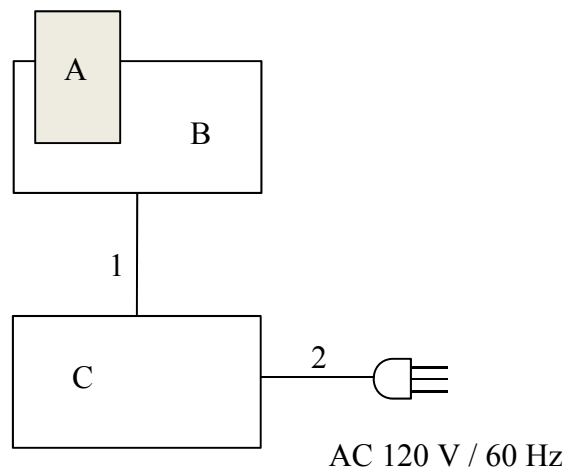

* Cabling and setup(s) were taken into consideration and test data was taken under worse case conditions.

Description of EUT and support equipment

No.	Item	Model number	Serial number	Manufacturer	Remarks
A	Zigbee Module	TPZMT-01T	1 *1) 10 *2)	Telepower	EUT
B	Jig	-	-	Telepower	*3)
C	Power Supply(DC)	PAN60-10A	NL002383	Kikusui	-

*1) Used for Antenna Terminal conducted test

*2) Used for Conducted Emission test and Radiated Emission test

*3) The test was performed with the module that as normal assumed implementation conditions.

The use of a jig does not influence on the test result.

List of cables used

No.	Name	Length (m)	Shield		Remarks
			Cable	Connector	
1	DC	0.9	Unshielded	Unshielded	-
2	AC	2.0	Unshielded	Unshielded	-

UL Japan, Inc.

Shonan EMC Lab.

1-22-3 Megumigaoka, Hiratsuka-shi, Kanagawa-ken, 259-1220 JAPAN

Telephone : +81 463 50 6400

Facsimile : +81 463 50 6401

SECTION 5: Conducted Emission

Test Procedure and conditions

EUT was placed on a platform of nominal size, 1.0 m by 2.0 m, raised 0.8 m above the conducting ground plane. The table is made of Styrofoam and covered with polyvinyl chloride. That has very low permittivity.

The rear of tabletop was located 40 cm to the vertical conducting plane. The rear of EUT, including peripherals aligned and flushed with rear of tabletop. All other surfaces of tabletop were at least 80 cm from any other grounded conducting surface. EUT was located 80 cm from a Line Impedance Stabilization Network (LISN) / Artificial mains Network (AMN) and excess AC cable was bundled in center.

The AC Mains Terminal Continuous disturbance Voltage has been measured with the EUT in a semi-anechoic chamber. The EUT was connected to a LISN (AMN).

An overview sweep with peak detection has been performed.

The test results and limit are rounded off to one decimal place, so some differences might be observed.

Detector	: QP and CISPR AV
Measurement range	: 0.15 MHz – 30 MHz
Test data	: APPENDIX
Test result	: Pass

SECTION 6: Radiated Spurious Emission

Test Procedure

It was measured based on "11.0 Emissions in non-restricted frequency bands" of "558074 D01 DTS Meas Guidance v04".

[For below 1 GHz]

EUT was placed on a platform of nominal size, 1.0 m by 2.0 m, raised 0.8 m above the conducting ground plane. The table is made of Styrofoam and covered with polyvinyl chloride. That has very low permittivity. The Radiated Electric Field Strength has been measured in a Semi Anechoic Chamber with a ground plane.

[For above 1 GHz]

EUT was placed on a urethane platform of nominal size, 0.5 m by 0.5 m, raised 1.5 m above the conducting ground plane.

The Radiated Electric Field Strength has been measured in a Semi Anechoic Chamber with absorbent materials lined on a ground plane.

The height of the measuring antenna varied between 1 and 4 m and EUT was rotated a full revolution in order to obtain the maximum value of the electric field strength.

The measurements were performed for both vertical and horizontal antenna polarization with the Test Receiver, or the Spectrum Analyzer.

The measurements were made with the following detector function of the test receiver and the Spectrum analyzer (in linear mode).

The test was made with the detector (RBW/VBW) in the following table.

When using Spectrum analyzer, the test was made with adjusting span to zero by using peak hold.

Test Antennas are used as below;

Frequency	30 MHz to 300 MHz	300 MHz to 1 GHz	Above 1 GHz
Antenna Type	Biconical	Logperiodic	Horn

In any 100 kHz bandwidth outside the restricted band in which the spread spectrum intentional radiator is operating, the radio frequency power that is produced by the intentional radiator confirmed 20 dB below that in the 100 kHz bandwidth within the band that contains the highest level of the desired power, based on a radiated measurement.

20 dBc was applied to the frequency over the limit of FCC 15.209 / Table 4 of RSS-Gen 8.9(IC) and outside the restricted band of FCC15.205 / Table 6 of RSS-Gen 8.10 (IC).

Frequency	Below 1 GHz	Above 1 GHz		20 dBc
Instrument used	Test Receiver	Spectrum Analyzer		Spectrum Analyzer
Detector	QP	PK	AV *3)	PK
IF Bandwidth	BW 120 kHz	RBW: 1 MHz VBW: 3 MHz	Average Power Method: RBW: 1 MHz VBW: 3 MHz Detector: Power Averaging (RMS) Trace: 100 traces If duty cycle was less than 98 %, a duty factor was added to the results.	RBW: 100 kHz VBW: 300kHz
Test Distance	3 m	3.98 m *1) (1 GHz – 13 GHz), 1 m *2) (13 GHz – 26.5 GHz)		3.98 m *1) (1 GHz – 13 GHz), 1 m *2) (13 GHz – 26.5 GHz)

*1) Distance Factor: $20 \times \log(3.98 \text{ m} / 3.0 \text{ m}) = 2.5 \text{ dB}$

*2) Distance Factor: $20 \times \log(1.0 \text{ m} / 3.0 \text{ m}) = -9.5 \text{ dB}$

*3) Average Power Measurement was performed based on 6.0 & 12.2.5 of "KDB 558074 D01 DTS Meas Guidance v04".

The carrier level and noise levels were confirmed at each position of X, Y and Z axes of EUT to see the position of maximum noise, and the test was made at the position that has the maximum noise.

	30 MHz-1000 MHz	1 GHz- 2.8 GHz	2.8 GHz- 13 GHz	13 GHz- 18 GHz	18 GHz-26.5 GHz
Horizontal	X	X	Z	Z	Z
Vertical	X	Z	Z	Z	Z

The test results and limit are rounded off to one decimal place, so some differences might be observed.

Measurement range : 30 MHz - 26.5 GHz
Test data : APPENDIX
Test result : Pass

SECTION 7: Antenna Terminal Conducted Tests

Test Procedure

The tests were made with below setting connected to the antenna port.

Test	Span	RBW	VBW	Sweep time	Detector	Trace	Instrument used
6dB Bandwidth	10 MHz	100 kHz	300 kHz	Auto	Peak	Max Hold	Spectrum Analyzer
99% Occupied Bandwidth *1)	Enough width to display emission skirts	1 to 5 % of OBW	Three times of RBW	Auto	Sample	Max Hold	Spectrum Analyzer
Maximum Peak Output Power	-	-	-	Auto	Peak/Average *2)	-	Power Meter (Sensor: 50 MHz BW)
Peak Power Density	1.5 times the 6dB Bandwidth	3 kHz	9.1 kHz	Auto	Peak	Max Hold	Spectrum Analyzer *3)
Conducted Spurious Emission *4)	9kHz to 150kHz	200 Hz	620 Hz	Auto	Peak	Max Hold	Spectrum Analyzer
	150kHz to 30MHz	10 kHz	30 kHz				
*1) Peak hold was applied as Worst-case measurement. *2) Reference data *3) Section 10.2 Method PKPSD (peak PSD) of "KDB 558074 D01 DTS Meas Guidance v04". *4) In the frequency range below 30MHz, RBW was narrowed to separate the noise contents. Then, wide-band noise near the limit was checked separately, however the noise was not detected as shown in the chart. (9 kHz - 150 kHz: RBW = 200 Hz, 150 kHz - 30 MHz: RBW = 10 kHz)							

The test results and limit are rounded off to two decimals place, so some differences might be observed.

Test data : **APPENDIX**
Test result : **Pass**

APPENDIX 1: Test data

Conducted Emission

DATA OF CONDUCTED EMISSION TEST

UL Japan, Inc. Shonan EMC Lab. No.2 Semi-Anechoic Chamber
Date : 2016/06/29

Mode : Tx 2405 MHz
Order No. : 11333790S
Temp./Humi. : 24 deg.C / 62 %RH

Limit1 : FCC 15C (15.207) QP
Limit2 : FCC 15C (15.207) AV

Engineer : Kazutaka Takeyama

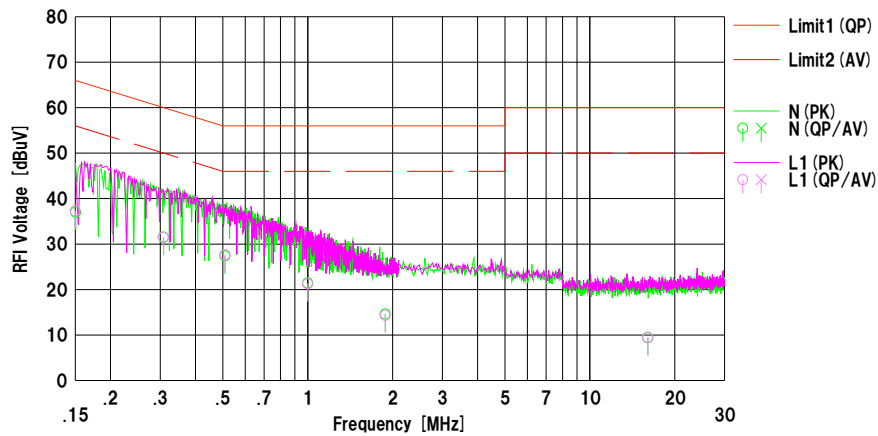

No.	Freq. [MHz]	Reading		C.Fac	Results		Limit		Margin		Phase	Comment
		<QP> [dBuV]	<AV> [dBuV]		<QP> [dBuV]	<AV> [dBuV]	<QP> [dBuV]	<AV> [dBuV]	<QP> [dB]	<AV> [dB]		
1	0.15063	24.40	---	12.60	37.00	---	65.97	55.97	28.9	---	N	
2	0.30845	18.90	---	12.63	31.53	---	60.01	50.01	28.4	---	N	
3	0.50917	14.70	---	12.66	27.36	---	56.00	46.00	28.6	---	N	
4	1.00072	8.70	---	12.73	21.43	---	56.00	46.00	34.5	---	N	
5	1.88411	1.80	---	12.80	14.60	---	56.00	46.00	41.4	---	N	
6	16.06361	-4.32	---	13.69	9.37	---	60.00	50.00	50.6	---	N	
7	0.15000	24.70	---	12.60	37.30	---	66.00	56.00	28.7	---	L1	
8	0.30845	18.80	---	12.63	31.43	---	60.01	50.01	28.5	---	L1	
9	0.50917	15.00	---	12.66	27.66	---	56.00	46.00	28.3	---	L1	
10	1.00072	8.50	---	12.73	21.23	---	56.00	46.00	34.7	---	L1	
11	1.88411	1.51	---	12.80	14.31	---	56.00	46.00	41.6	---	L1	
12	16.06000	-4.20	---	13.69	9.49	---	60.00	50.00	50.5	---	L1	

Calculation: Result [dBuV] = Reading [dBuV] + C.Fac (LISN+Cable+ATT) [dB]
LISN-SLS-03

Conducted Emission

DATA OF CONDUCTED EMISSION TEST

UL Japan, Inc. Shonan EMC Lab. No.2 Semi-Anechoic Chamber
Date : 2016/06/30

Mode : Tx 2440 MHz
Order No. : 11333790S
Temp./Humi. : 24 deg.C / 62 %RH

Limit1 : FCC 15C (15.207) QP
Limit2 : FCC 15C (15.207) AV

Engineer : Kazutaka Takeyama

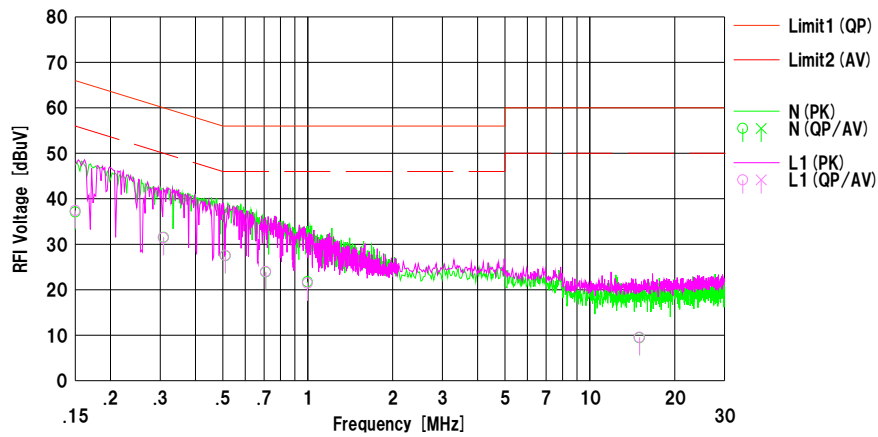

No.	Freq. [MHz]	Reading		C.Fac	Results		Limit		Margin		Phase	Comment
		<QP> [dBuV]	<AV> [dBuV]		<QP> [dBuV]	<AV> [dBuV]	<QP> [dBuV]	<AV> [dBuV]	<QP> [dB]	<AV> [dB]		
1	0.15000	24.50	---	12.60	37.10	---	66.00	56.00	28.9	---	N	
2	0.30858	18.90	---	12.63	31.53	---	60.01	50.01	28.4	---	N	
3	0.51052	14.80	---	12.66	27.46	---	56.00	46.00	28.5	---	N	
4	0.71030	11.20	---	12.68	23.88	---	56.00	46.00	32.1	---	N	
5	0.99899	9.00	---	12.73	21.73	---	56.00	46.00	34.2	---	N	
6	14.99739	-4.20	---	13.63	9.43	---	60.00	50.00	50.5	---	N	
7	0.15000	24.80	---	12.60	37.40	---	66.00	56.00	28.6	---	L1	
8	0.30800	18.80	---	12.63	31.43	---	60.02	50.02	28.5	---	L1	
9	0.51052	14.90	---	12.66	27.56	---	56.00	46.00	28.4	---	L1	
10	0.71030	11.30	---	12.68	23.98	---	56.00	46.00	32.0	---	L1	
11	0.99899	8.70	---	12.73	21.43	---	56.00	46.00	34.5	---	L1	
12	14.99739	-4.10	---	13.63	9.53	---	60.00	50.00	50.4	---	L1	

Calculation: Result [dBuV] = Reading [dBuV] + C.Fac (LISN+Cable+ATT) [dB]
LISN:SLS-03

Conducted Emission

DATA OF CONDUCTED EMISSION TEST

UL Japan, Inc. Shonan EMC Lab. No.2 Semi-Anechoic Chamber
Date : 2016/06/30

Mode : Tx 2480 MHz
Order No. : 11333790S
Temp./Humi. : 24 deg.C / 62 %RH

Limit1 : FCC 15C (15.207) QP
Limit2 : FCC 15C (15.207) AV

Engineer : Kazutaka Takeyama

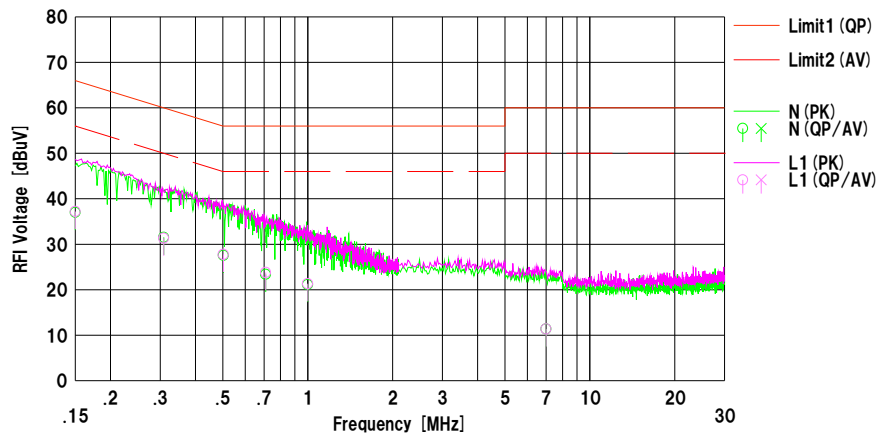

No.	Freq. [MHz]	Reading		C.Fac	Results		Limit		Margin		Phase	Comment
		<QP> [dBuV]	<AV> [dBuV]		<QP> [dBuV]	<AV> [dBuV]	<QP> [dBuV]	<AV> [dBuV]	<QP> [dB]	<AV> [dB]		
1	0.15000	24.40	---	12.60	37.00	---	66.00	56.00	29.0	---	N	
2	0.30891	18.90	---	12.63	31.53	---	60.00	50.00	28.4	---	N	
3	0.50300	14.90	---	12.66	27.56	---	56.00	46.00	28.4	---	N	
4	0.70960	10.70	---	12.68	23.38	---	56.00	46.00	32.6	---	N	
5	1.00000	8.40	---	12.73	21.13	---	56.00	46.00	34.8	---	N	
6	6.99485	-1.80	---	13.17	11.37	---	60.00	50.00	48.6	---	N	
7	0.15000	24.60	---	12.60	37.20	---	66.00	56.00	28.8	---	L1	
8	0.30891	18.70	---	12.63	31.33	---	60.00	50.00	28.6	---	L1	
9	0.50250	15.10	---	12.66	27.76	---	56.00	46.00	28.2	---	L1	
10	0.70987	11.10	---	12.68	23.78	---	56.00	46.00	32.2	---	L1	
11	0.99992	8.60	---	12.73	21.33	---	56.00	46.00	34.6	---	L1	
12	6.99485	-1.80	---	13.17	11.37	---	60.00	50.00	48.6	---	L1	

Calculation: Result [dBuV] = Reading [dBuV] + C.Fac (LISN+Cable+ATT) [dB]
LISN:SLS-03

6 dB Bandwidth and 99 % Occupied Bandwidth

Test place Shonan EMC Lab. No.5 Shielded Room
Report No. 11333790S-A-R3
Date June 28, 2016
Temperature / Humidity 25 deg. C / 51 % RH
Engineer Hiroyuki Morikawa
Mode Tx

Mode	Frequency [MHz]	99% Occupied Bandwidth [kHz]	6dB Bandwidth [MHz]	Limit for 6dB Bandwidth [MHz]
Tx	2405	2642.5	1.508	> 0.5000
	2440	2644.7	1.489	> 0.5000
	2480	2653.4	1.511	> 0.5000

6dB Bandwidth

Tx

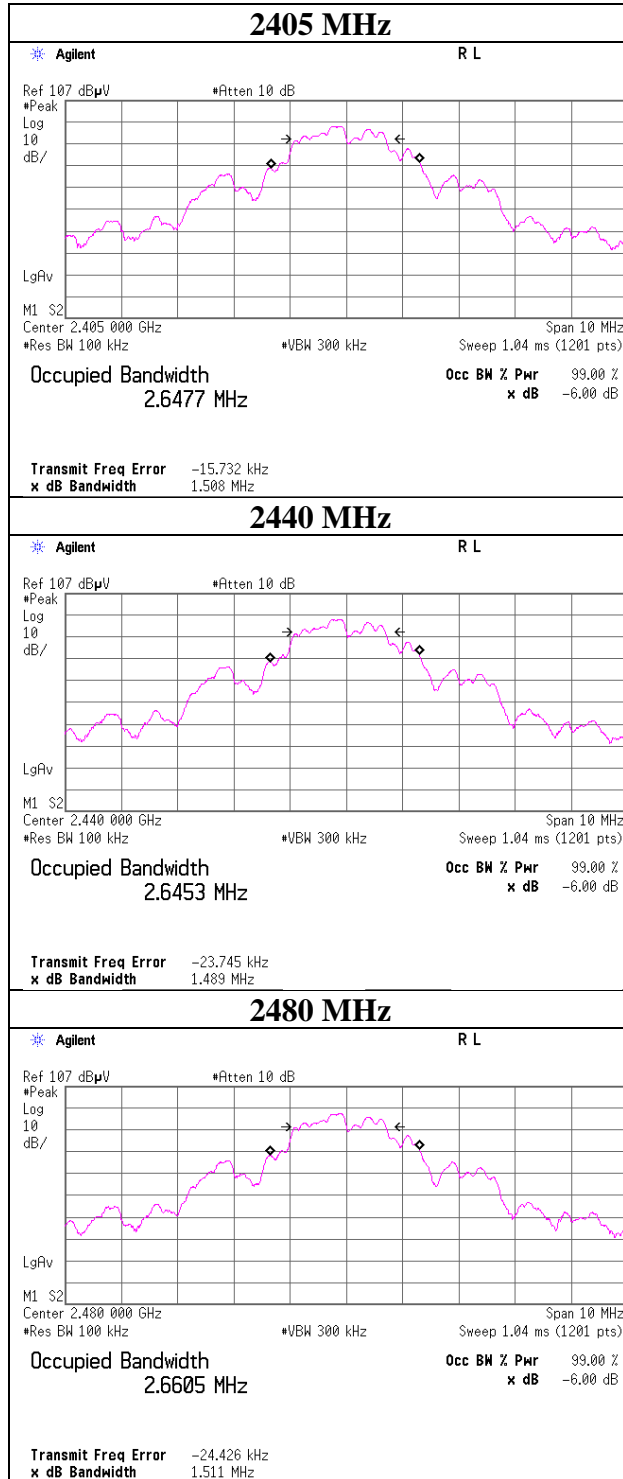

UL Japan, Inc.

Shonan EMC Lab.

1-22-3 Megumigaoka, Hiratsuka-shi, Kanagawa-ken, 259-1220 JAPAN

Telephone : +81 463 50 6400

Facsimile : +81 463 50 6401

99%Occupied Bandwidth

Test place	Shonan EMC Lab. No.5 Shielded Room
Report No.	11333790S-A-R3
Date	June 28, 2016
Temperature / Humidity	25 deg. C / 51 % RH
Engineer	Hiroyuki Morikawa
Mode	Tx

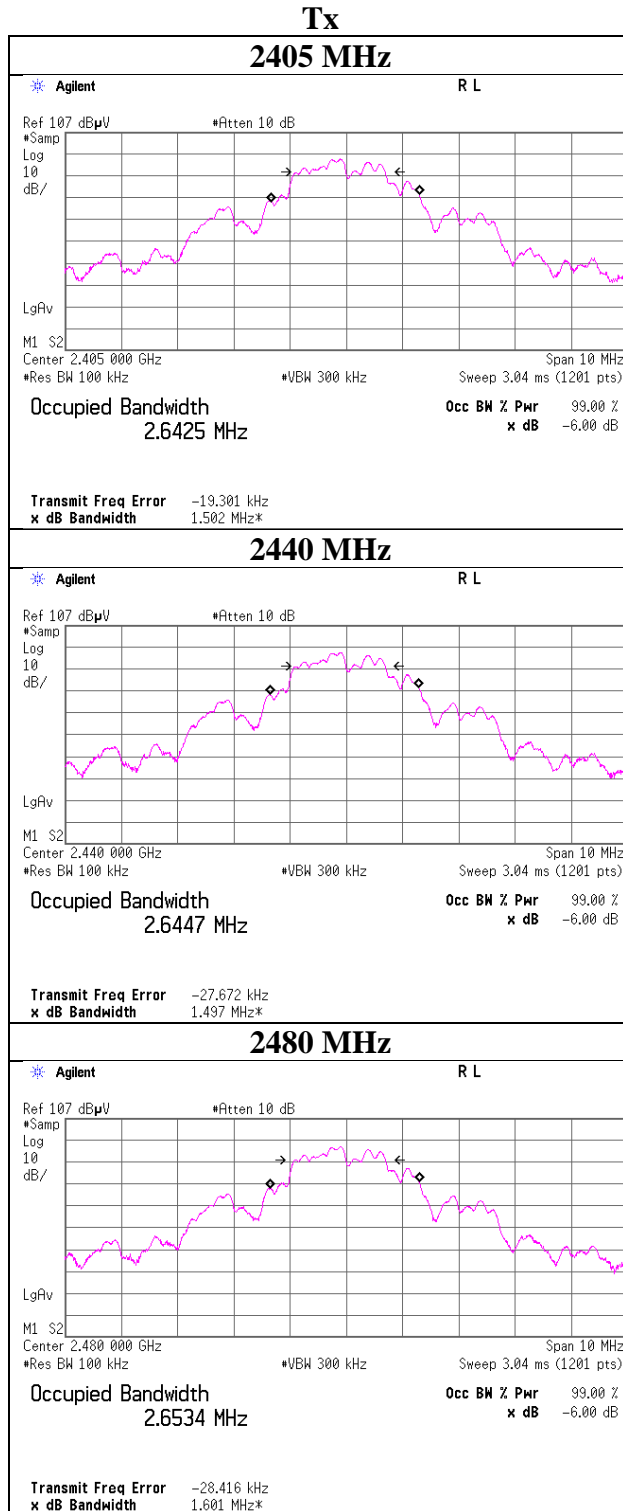

Maximum Peak Output Power

Test place Shonan EMC Lab. No.5 Shielded Room
Report No. 11333790S-A-R3
Date July 8, 2016
Temperature / Humidity 24 deg. C / 52 % RH
Engineer Yosuke Ishikawa
Mode Tx

Freq. [MHz]	Reading [dBm]	Cable Loss [dB]	Atten. Loss [dB]	Result		Limit		Margin [dB]
				[dBm]	[mW]	[dBm]	[mW]	
2405	-7.87	1.72	9.67	3.52	2.25	30.00	1000	26.48
2440	-8.19	1.70	9.67	3.18	2.08	30.00	1000	26.82
2480	-8.62	1.70	9.67	2.75	1.88	30.00	1000	27.25

Sample Calculation:

Result = Reading + Cable Loss (including the cables) + Attenuator Loss

Burst rate confirmation

Test place	Shonan EMC Lab. No.5 Shielded Room
Report No.	11333790S-A-R3
Date	June 28, 2016
Temperature / Humidity	25 deg. C / 51 % RH
Engineer	Hiroyuki Morikawa
Mode	Tx

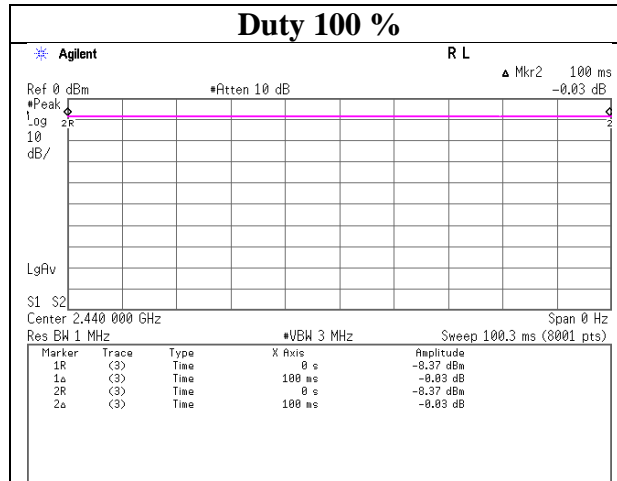

Radiated Spurious Emission

Test place : Shonan EMC Lab. No.1 Semi Anechoic Chamber
Report No. : 11333790S-A-R3
Date : June 29, 2016 June 28, 2016
Temperature / Humidity : 23 deg. C / 68 % RH 22 deg. C / 54 % RH
Engineer : Kazutaka Takeyama Kazutaka Takeyama
 (30 – 1000 MHz) (1 – 26.5 GHz)
Mode : Tx 2405 MHz

(* PK: Peak, AV: Average, QP: Quasi-Peak)

Polarity	Frequency [MHz]	Detector	Reading [dBuV]	Ant.Fac. [dB/m]	Loss [dB]	Gain [dB]	Distance Factor [dB]	Result [dBuV/m]	Limit [dBuV/m]	Margin [dB]	Height [cm]	Angle [deg]	Remark
Hori.	56.897	QP	21.3	8.7	7.1	31.9	0.0	5.2	40.0	34.8	150	204	
Hori.	165.000	QP	29.9	15.3	8.7	31.8	0.0	22.1	43.5	21.4	209	144	
Hori.	234.126	QP	21.8	17.3	9.3	31.7	0.0	16.7	46.0	29.3	150	45	
Hori.	2390.000	PK	41.3	27.7	13.8	40.7	2.5	44.6	73.9	29.3	100	60	
Hori.	4810.000	PK	59.0	31.4	6.0	41.5	2.5	57.4	73.9	16.5	100	23	
Hori.	7215.000	PK	50.0	36.6	7.3	41.1	2.5	55.3	73.9	18.6	100	172	
Hori.	9620.000	PK	44.0	37.9	8.1	40.5	2.5	52.0	73.9	21.9	100	0	
Hori.	2390.000	AV	34.3	27.7	13.8	40.7	2.5	37.6	53.9	16.3	100	60	
Hori.	4810.000	AV	54.9	31.4	6.0	41.5	2.5	53.3	53.9	0.6	100	23	
Hori.	7215.000	AV	40.3	36.6	7.3	41.1	2.5	45.6	53.9	8.3	100	172	
Hori.	9620.000	AV	34.0	37.9	8.1	40.5	2.5	42.0	53.9	11.9	100	0	
Vert.	101.266	QP	22.3	10.3	8.0	31.9	0.0	8.7	43.5	34.8	100	17	
Vert.	166.000	QP	27.5	15.3	8.7	31.8	0.0	19.7	43.5	23.8	100	212	
Vert.	402.819	QP	21.5	16.3	7.3	31.6	0.0	13.5	46.0	32.5	100	48	
Vert.	2390.000	PK	41.0	27.7	13.8	40.7	2.5	44.3	73.9	29.6	100	0	
Vert.	4810.000	PK	59.2	31.4	6.0	41.5	2.5	57.6	73.9	16.3	100	168	
Vert.	7215.000	PK	47.0	36.6	7.3	41.1	2.5	52.3	73.9	21.6	100	131	
Vert.	9620.000	PK	42.8	37.9	8.1	40.5	2.5	50.8	73.9	23.1	100	0	
Vert.	2390.000	AV	33.9	27.7	13.8	40.7	2.5	37.2	53.9	16.7	100	0	
Vert.	4810.000	AV	55.0	31.4	6.0	41.5	2.5	53.4	53.9	0.5	100	168	
Vert.	7215.000	AV	40.0	36.6	7.3	41.1	2.5	45.3	53.9	8.6	100	131	
Vert.	9620.000	AV	34.6	37.9	8.1	40.5	2.5	42.6	53.9	11.3	100	0	

Result = Reading + Ant.Fac. + Loss (Cable+(Attenuator or Filter)(below 18 GHz)) - Gain(Amplifier) + Distance factor

Distance factor : 1 GHz - 13 GHz : 20log(3.98 m / 3.0 m) = 2.5 dB

13 GHz - 40 GHz : 20log(1.0 m / 3.0 m) = -9.5 dB

20 dBc Data Sheet (RBW 100 kHz, VBW 300 kHz)

Polarity	Frequency [MHz]	Detector	Reading [dBuV]	Ant.Fac. [dB/m]	Loss [dB]	Gain [dB]	Distance Factor [dB]	Result [dBuV/m]	Limit [dBuV/m]	Margin [dB]	Remark
Hori.	2405.000	PK	74.2	27.7	13.8	40.7	2.5	77.5	-	-	
Hori.	2400.000	PK	33.6	27.7	13.8	40.7	2.5	36.9	57.5	20.6	
Vert.	2405.000	PK	71.5	27.7	13.8	40.7	2.5	74.8	-	-	
Vert.	2400.000	PK	33.5	27.7	13.8	40.7	2.5	36.8	74.8	38.0	

Result = Reading + Ant.Fac. + Loss (Cable+(Attenuator or Filter)(below 18 GHz)) - Gain(Amplifier) + Distance factor

Distance factor : 1 GHz - 13 GHz : 20log(3.98 m / 3.0 m) = 2.5 dB

13 GHz - 40 GHz : 20log(1.0 m / 3.0 m) = -9.5 dB

Radiated Spurious Emission
(Reference Plot for band-edge)

Test place	Shonan EMC Lab. No.1 Semi Anechoic Chamber
Report No.	11333790S-A-R3
Date	June 28, 2016
Temperature / Humidity	22 deg. C / 54 % RH
Engineer	Kazutaka Takeyama (1 – 26.5 GHz)
Mode	Tx 2405 MHz

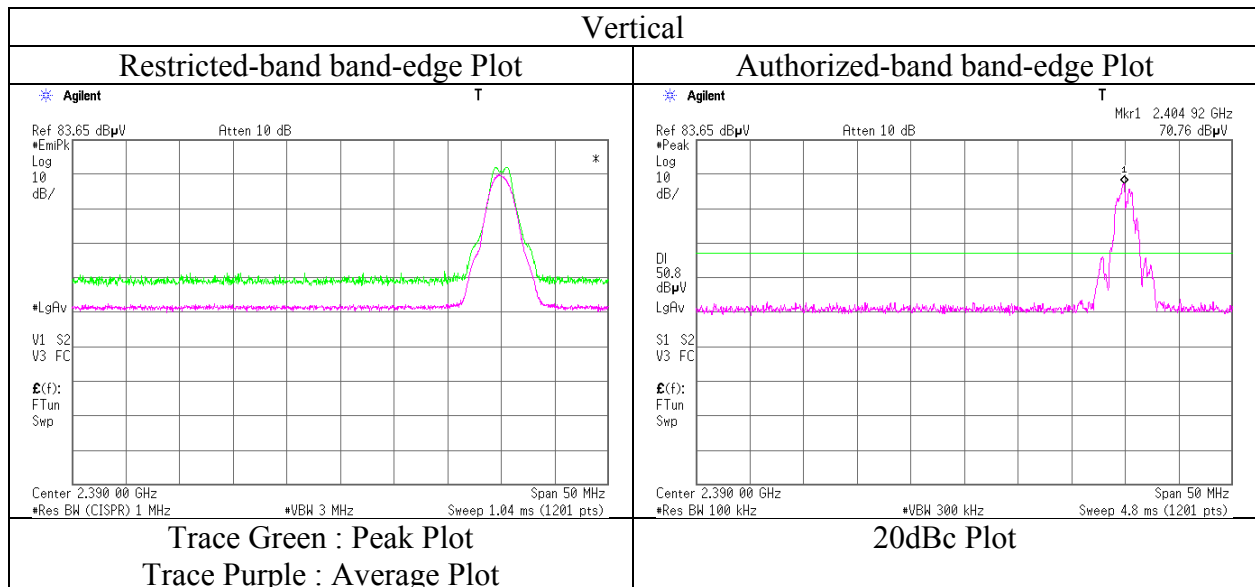
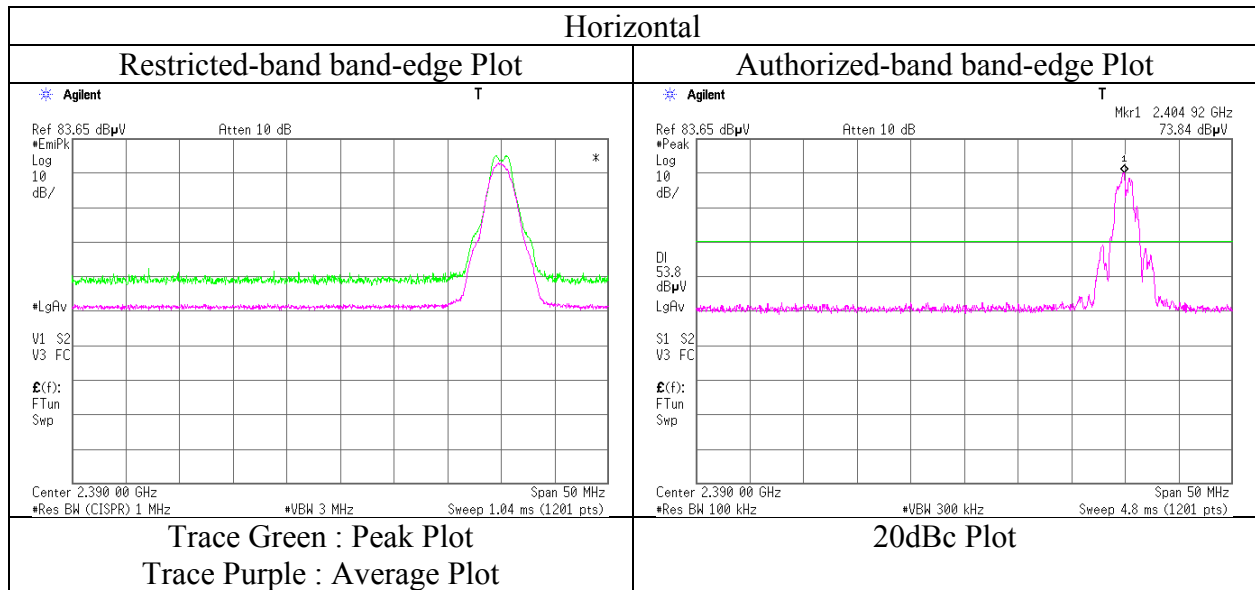

* Final result of restricted band edge was shown in tabular data.

Radiated Spurious Emission
(Reference Plot for band-edge)

Test place	Shonan EMC Lab. No.1 Semi Anechoic Chamber
Report No.	11333790S-A-R3
Date	June 28, 2016
Temperature / Humidity	22 deg. C / 54 % RH
Engineer	Kazutaka Takeyama
	(1 – 26.5 GHz)
Mode	Tx 2480 MHz

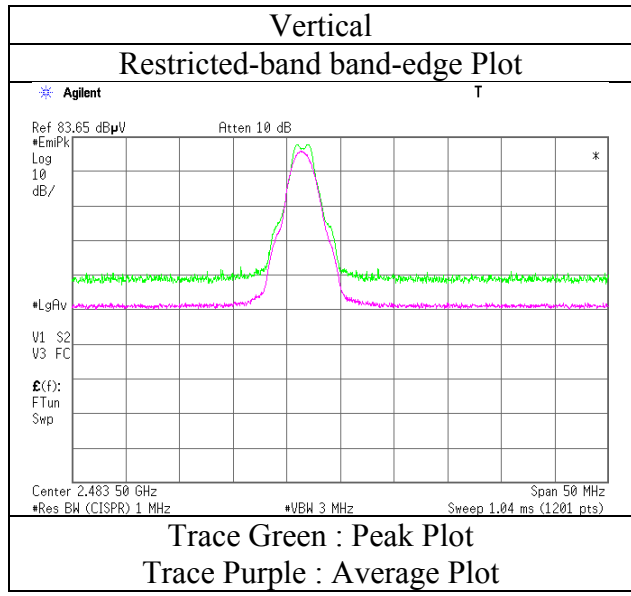
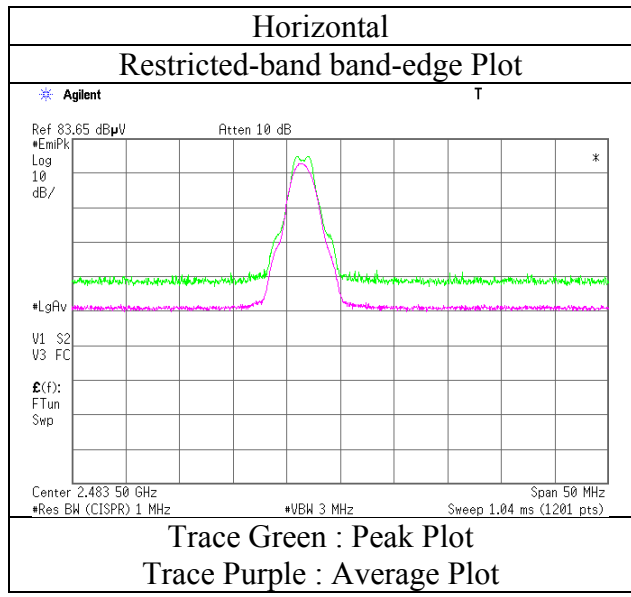

* Final result of restricted band edge was shown in tabular data.

Radiated Spurious Emission (Plot data, Worst case)

Test place	Shonan EMC Lab. No.1 and 2 Semi Anechoic Chamber	
Report No.	11333790S-A-R3	
Date	June 28, 2016	June 29, 2016
Temperature / Humidity	23 deg. C / 68 % RH	22 deg. C / 68 % RH
Engineer	Kazutaka Takeyama (30 – 1000 MHz)	Kazutaka Takeyama (1 – 26.5 GHz)
Mode	Tx 2405 MHz	

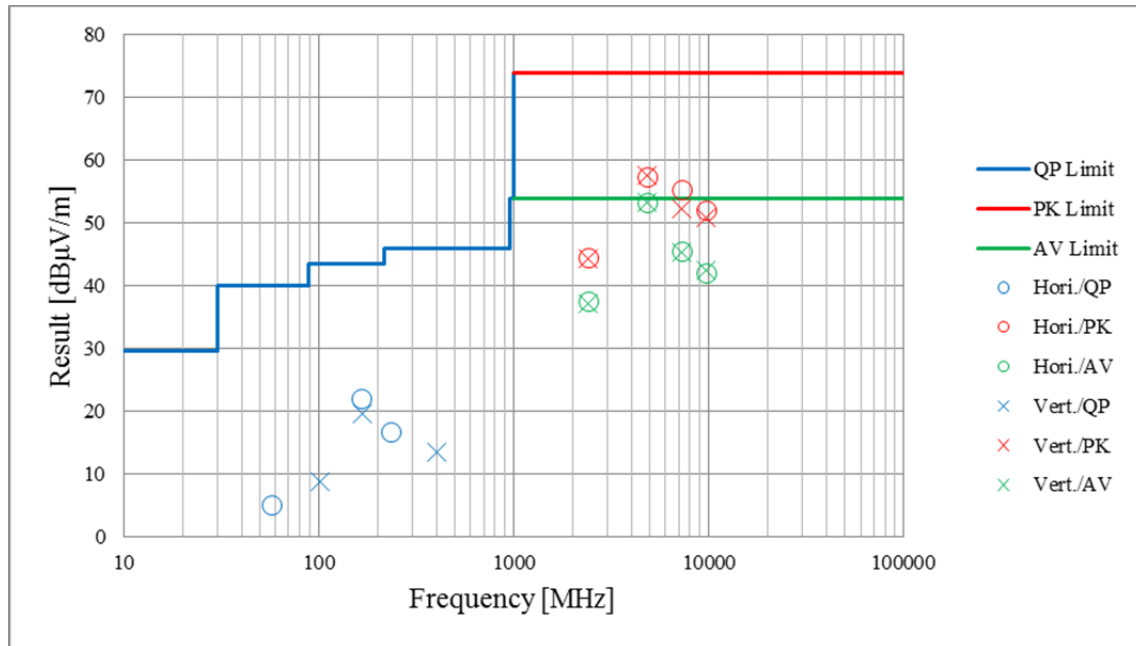

*These plots data contains sufficient number to show the trend of characteristic features for EUT.

Conducted Spurious Emission

Test place : Shonan EMC Lab. No.5 Shielded Room
 Report No. : 11333790S-A-R3
 Date : June 28, 2016
 Temperature / Humidity : 25 deg. C / 51 % RH
 Engineer : Hiroyuki Morikawa
 Mode : Tx 2405 MHz

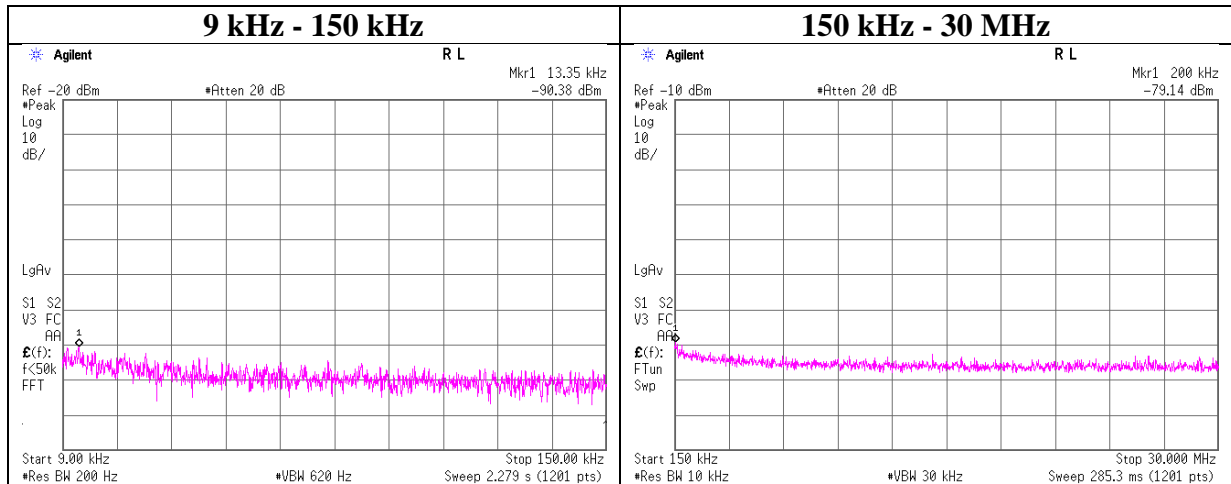

Frequency [kHz]	Reading [dBm]	Cable Loss [dB]	Attenuator Loss [dB]	Antenna Gain [dBi]	N (Number of Output)	EIRP [dBm]	Distance [m]	Ground bounce [dB]	E (field strength) [dBuV/m]	Limit [dBuV/m]	Margin [dB]	Remark
13.35	-90.4	0.02	9.5	2.5	1	-78.3	300	6.0	-17.1	45.0	62.1	
200.00	-79.1	0.02	9.5	2.5	1	-67.1	300	6.0	-5.8	21.5	27.3	

$E = \text{EIRP} - 20 \log(D) + \text{Ground bounce} + 104.8 \text{ [dBuV/m]}$

$\text{EIRP} = \text{Reading} + \text{Cable Loss} + \text{Attenuator Loss} + \text{Antenna Gain} + 10 * \log(N)$

Conducted Spurious Emission

Test place	Shonan EMC Lab. No.5 Shielded Room
Report No.	11333790S-A-R3
Date	June 28, 2016
Temperature / Humidity	25 deg. C / 51 % RH
Engineer	Hiroyuki Morikawa
Mode	Tx 2440 MHz

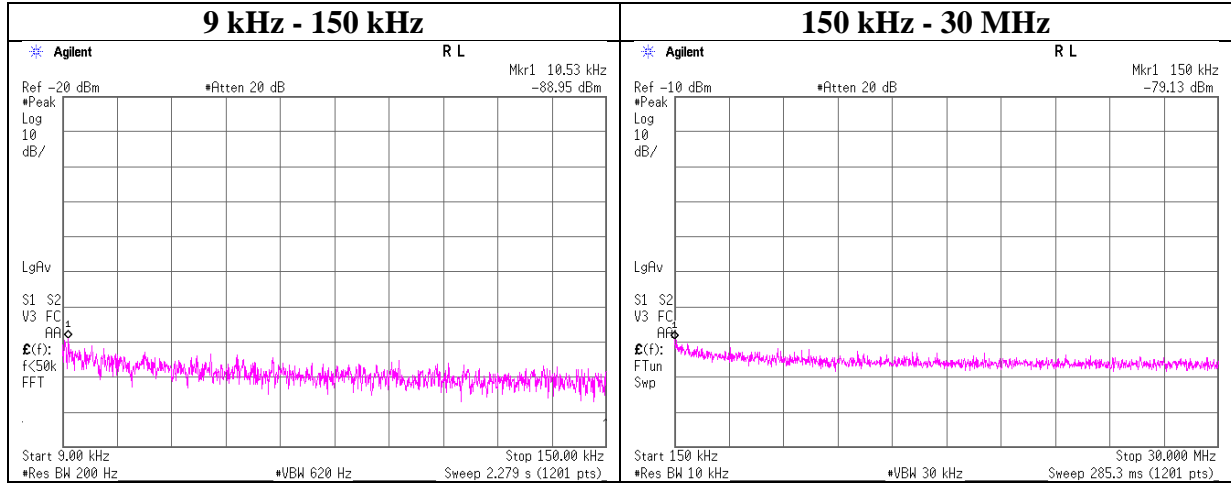

Frequency [kHz]	Reading [dBm]	Cable Loss [dB]	Attenuator Loss [dB]	Antenna Gain [dBi]	N (Number of Output)	EIRP [dBm]	Distance [m]	Ground bounce [dB]	E (field strength) [dBuV/m]	Limit [dBuV/m]	Margin [dB]	Remark
10.53	-89.0	0.02	9.5	2.5	1	-76.9	300	6.0	-15.6	47.1	62.7	
150.00	-79.1	0.02	9.5	2.5	1	-67.1	300	6.0	-5.8	24.0	29.8	

$E = \text{EIRP} - 20 \log(D) + \text{Ground bounce} + 104.8 \text{ [dBuV/m]}$

$\text{EIRP} = \text{Reading} + \text{Cable Loss} + \text{Attenuator Loss} + \text{Antenna Gain} + 10 * \log(N)$

Conducted Spurious Emission

Test place : Shonan EMC Lab. No.5 Shielded Room
 Report No. : 11333790S-A-R3
 Date : June 28, 2016
 Temperature / Humidity : 25 deg. C / 51 % RH
 Engineer : Hiroyuki Morikawa
 Mode : Tx 2480 MHz

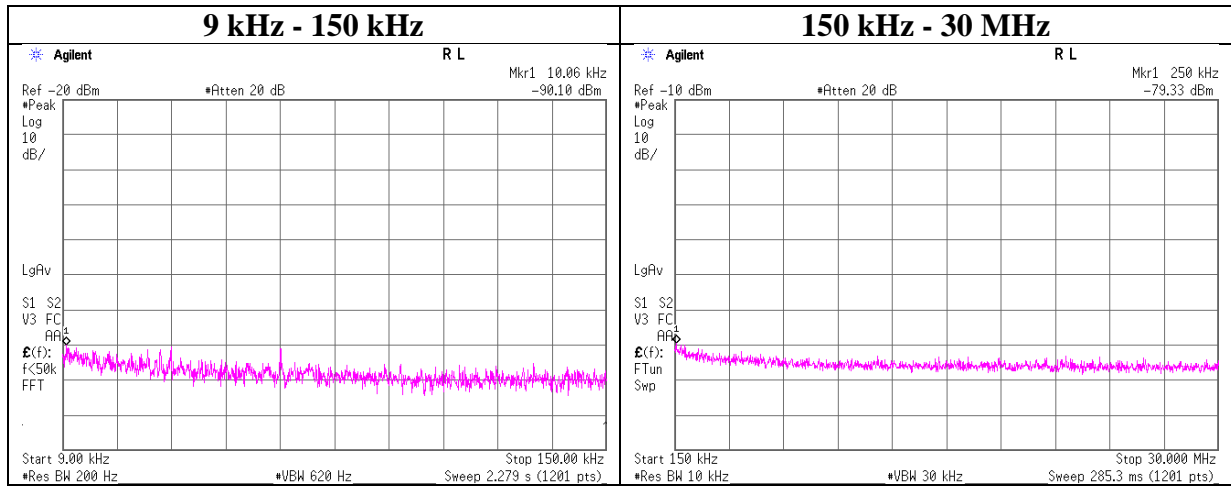

Frequency [kHz]	Reading [dBm]	Cable Loss [dB]	Attenuator Loss [dB]	Antenna Gain [dBi]	N (Number of Output)	EIRP [dBm]	Distance [m]	Ground bounce [dB]	E (field strength) [dBuV/m]	Limit [dBuV/m]	Margin [dB]	Remark
10.06	-90.1	0.02	9.5	2.5	1	-78.0	300	6.0	-16.8	47.5	64.3	
250.00	-79.3	0.02	9.5	2.5	1	-67.3	300	6.0	-6.0	19.6	25.6	

$E = \text{EIRP} - 20 \log(D) + \text{Ground bounce} + 104.8 \text{ [dBuV/m]}$

$\text{EIRP} = \text{Reading} + \text{Cable Loss} + \text{Attenuator Loss} + \text{Antenna Gain} + 10 * \log(N)$

UL Japan, Inc.

Shonan EMC Lab.

1-22-3 Megumigaoka, Hiratsuka-shi, Kanagawa-ken, 259-1220 JAPAN

Telephone : +81 463 50 6400

Facsimile : +81 463 50 6401

Power Density

Test place Shonan EMC Lab. No.5 Shielded Room
Report No. 11333790S-A-R3
Date June 28, 2016
Temperature / Humidity 25 deg. C / 51 % RH
Engineer Hiroyuki Morikawa
Mode Tx

Freq.	Reading	Cable Loss	Atten. Loss	Result	Limit	Margin
[MHz]	[dBm]	[dB]	[dB]	[dBm]	[dBm]	[dB]
2405.00	-17.32	1.72	9.67	-5.93	8.00	13.93
2440.00	-17.37	1.70	9.67	-6.00	8.00	14.00
2480.00	-17.95	1.70	9.67	-6.58	8.00	14.58

Sample Calculation:

Result = Reading + Cable Loss (including the cables) + Attenuator Loss

Power Density

Tx

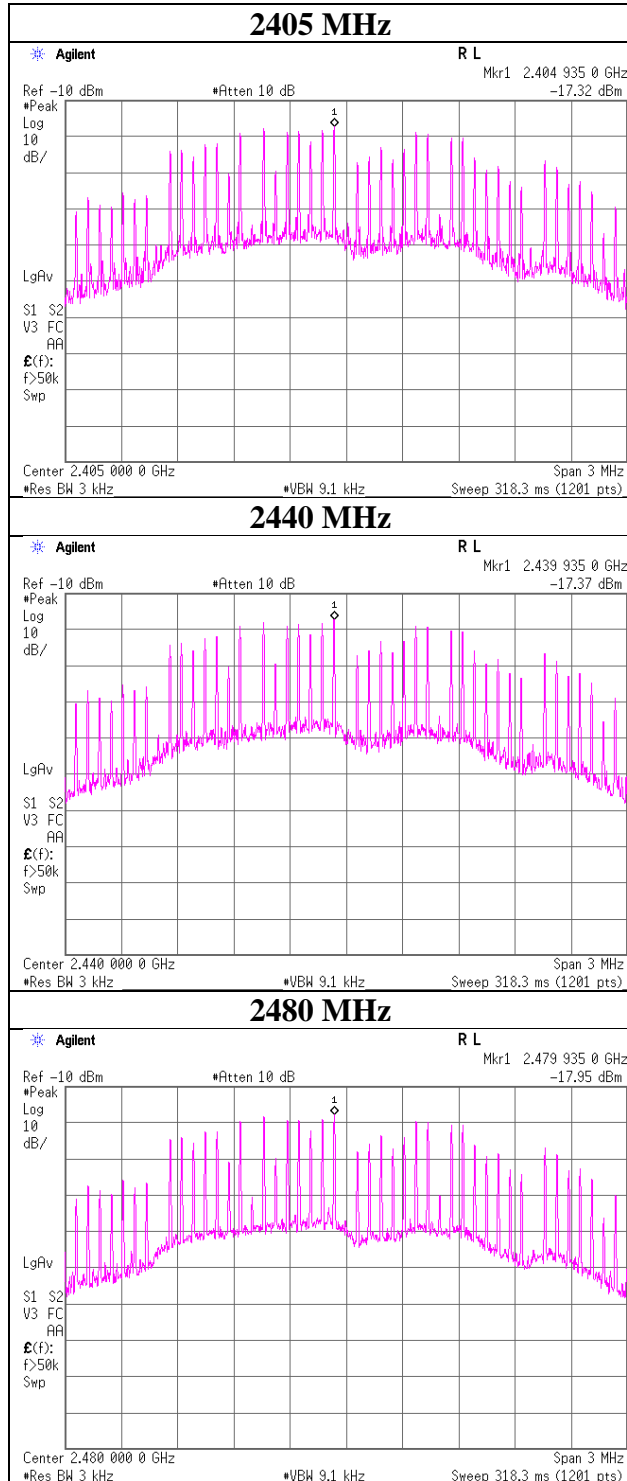

UL Japan, Inc.

Shonan EMC Lab.

1-22-3 Megumigaoka, Hiratsuka-shi, Kanagawa-ken, 259-1220 JAPAN

Telephone : +81 463 50 6400

Facsimile : +81 463 50 6401

APPENDIX 2: Test instruments

Test equipment

Control No.	Instrument	Manufacturer	Model No	Serial No	Test Item	Calibration Date * Interval(month)
SAF-04	Pre Amplifier	TOYO Corporation	TPA0118-36	1440489	RE	2016/03/22 * 12
SCC-G06	Coaxial Cable	Junkosha	J12J102207-00	MAY-23-16-091	RE	2016/06/14 * 12
SCC-G21	Coaxial Cable	Suhner	SUCOFLEX 104	296169/4	RE	2016/05/11 * 12
SHA-01	Horn Antenna	Schwarzbeck	BBHA9120D	9120D-725	RE	2015/08/10 * 12
SOS-01	Humidity Indicator	A&D	AD-5681	4062555	RE	2015/10/22 * 12
SSA-03	Spectrum Analyzer	Agilent	E4448A	MY48250152	RE	2015/09/16 * 12
SJM-02	Measure	KOMELON	KMC-36	-	RE	-
SAEC-01(SVSWR)	Semi-Anechoic Chamber	TDK	SAEC-01(SVSWR)	1	RE	2015/07/08 * 12
COTS-SEMI-1	EMI Software	TSJ	TEPTO-DV(RE,CE,RFI,MF)	-	RE,CE	-
STS-01	Digital Hitester	Hioki	3805-50	080997812	RE	2015/11/18 * 12
SAT10-05	Attenuator(above1GHz)	Agilent	8493C-010	74864	RE	2015/11/04 * 12
SAF-02	Pre Amplifier	SONOMA	310N	290212	RE	2016/02/19 * 12
SCC-G15	Coaxial Cable	Suhner	SUCOFLEX 102	32703/2	RE	2016/03/08 * 12
SCC-G33	Coaxial Cable	Junkosha	MWX241-01000KMSKMS	-	RE	2016/04/18 * 12
SAF-08	Pre Amplifier	TOYO Corporation	HAP18-26W	00000019	RE	2016/03/23 * 12
SHA-04	Horn Antenna	ETS LINDGREN	3160-09	LM3640	RE	2016/03/15 * 12
SAT6-02	Attenuator	JFW	50HF-006N	-	RE	2016/02/25 * 12
KAT3-11	Attenuator	JFW IND. INC.	50HF-003N	-	RE	2015/08/31 * 12
SBA-02	Biconical Antenna	Schwarzbeck	BBA9106	91032665	RE	2015/11/02 * 12
SCC-B1/B3/B5/B7/B8/B13/SRSE-02	Coaxial Cable&RF Selector	Fujikura/Fujikura/Suhner/Suhner/Suhner/Suhner/TOYO	8D2W/12DSFA/141PE/141PE/141PE/141PE/NS4906	-/0901-270(RF Selector)	RE	2016/04/22 * 12
SCC-B2/B4/B6/B7/B8/B13/SRSE-02	Coaxial Cable&RF Selector	Fujikura/Fujikura/Suhner/Suhner/Suhner/Suhner/TOYO	8D2W/12DSFA/141PE/141PE/141PE/141PE/NS4906	-/0901-270(RF Selector)	RE	2016/04/22 * 12
SLA-02	Logperiodic Antenna	Schwarzbeck	UHALP9108A	UHALP 9108-A0893	RE	2015/11/03 * 12
SOS-03	Humidity Indicator	A&D	AD-5681	4063325	RE,CE	2015/10/22 * 12
STR-07	Test Receiver	Rohde & Schwarz	ESU26	100484	RE,CE	2015/09/04 * 12
SJM-09	Measure	PROMART	SEN1935	-	RE,CE	-
SAEC-02(NSA)	Semi-Anechoic Chamber	TDK	SAEC-02(NSA)	2	RE	2015/07/15 * 12
STS-02	Digital Hitester	Hioki	3805-50	080997819	RE,CE	2016/03/22 * 12
SCC-B9/B10/B11/B13/SRSE-02	Coaxial Cable&RF Selector	Suhner/Fujikura/Suhner/Suhner/TOYO	RG223U/12DSFA/141PE/NS4906	-/0901-270(RF Selector)	CE	2016/04/22 * 12
SLS-03	LISN	Rohde & Schwarz	ENV216	100513	CE	2016/02/08 * 12
SAT3-06	Attenuator	JFW	50HF-003N	-	CE	2016/02/25 * 12
SSA-03	Spectrum Analyzer	Agilent	E4448A	MY48250152	AT	2015/09/16 * 12
SPM-07	Power Meter	Agilent	8990B	MY5100272	AT	2016/04/04 * 12
SPSS-04	Power sensor	Agilent	N1923A	MY5326009	AT	2016/04/04 * 12
SCC-G14	Coaxial Cable	Suhner	SUCOFLEX 102	31600/2	AT	2016/03/23 * 12
SAT10-09	Attenuator	Weinschel Corp.	54A-10	W5692	AT	2015/11/04 * 12
STS-05	Digital Hitester	Hioki	3805-50	080997828	AT	2015/11/18 * 12
SOS-09	Humidity Indicator	A&D	AD-5681	4061484	AT	2015/12/07 * 12
SCC-H11	Microwave cable	RS Pro	R-132G7210 100CO	-	AT	2016/04/18 * 12

The expiration date of the calibration is the end of the expired month.

All equipment is calibrated with valid calibrations. Each measurement data is traceable to the national or international standards.

As for some calibrations performed after the tested dates, those test equipment have been controlled by means of an unbroken chains of calibrations.

Test Item: CE: Conducted Emission test
RE: Radiated Emission test
AT: Antenna Terminal Conducted test

UL Japan, Inc.

Shonan EMC Lab.

1-22-3 Megumigaoka, Hiratsuka-shi, Kanagawa-ken, 259-1220 JAPAN

Telephone : +81 463 50 6400

Facsimile : +81 463 50 6401