



# RADIO TEST REPORT

**Test Report No. : 12858370S-A-R2**

**Applicant** : Telepower Inc.  
**Type of Equipment** : BLE module  
**Model No.** : MTBLE-01  
**FCC ID** : WQYMTBLE1  
**Test regulation** : FCC Part 15 Subpart C: 2018  
**Test Result** : Complied (Refer to SECTION 3.2)

1. This test report shall not be reproduced in full or partial, without the written approval of UL Japan, Inc.
2. The results in this report apply only to the sample tested.
3. This sample tested is in compliance with the limits of the above regulation.
4. The test results in this test report are traceable to the national or international standards.
5. This test report must not be used by the customer to claim product certification, approval, or endorsement by any agency of the Federal Government.
6. This test report covers Radio technical requirements.  
It does not cover administrative issues such as Manual or non-Radio test related Requirements. (if applicable)
7. The all test items in this test report are conducted by UL Japan, Inc. Shonan EMC Lab.
8. The opinions and the interpretations to the result of the description in this report are outside scopes where UL Japan has been accredited.
9. The information provided from the customer for this report is identified in SECTION 1.
10. This report is a revised version of 12858370S-A-R1. 12858370S-A-R1 is replaced with this report.

**Date of test:** May 14 to 16, 2019

**Representative test engineer:** K. Takeyama  
Kazutaka Takeyama  
Engineer  
Consumer Technology Division

**Approved by:** S. Kobayashi  
Shiro Kobayashi  
Engineer  
Consumer Technology Division



CERTIFICATE 1266.03

- The testing in which "Non-accreditation" is displayed is outside the accreditation scopes in UL Japan.  
 There is no testing item of "Non-accreditation".

**UL Japan, Inc.**  
**Shonan EMC Lab.**

1-22-3 Megumigaoka, Hiratsuka-shi, Kanagawa-ken, 259-1220 JAPAN  
Telephone : +81 463 50 6400  
Facsimile : +81 463 50 6401



<b>CONTENTS</b>	<b>PAGE</b>
<b>SECTION 1: Customer information.....</b>	<b>4</b>
<b>SECTION 2: Equipment under test (E.U.T.).....</b>	<b>4</b>
<b>SECTION 3: Test specification, procedures &amp; results.....</b>	<b>5</b>
<b>SECTION 4: Operation of E.U.T. during testing.....</b>	<b>8</b>
<b>SECTION 5: Conducted Emission.....</b>	<b>10</b>
<b>SECTION 6: Radiated Spurious Emission .....</b>	<b>11</b>
<b>SECTION 7: Antenna Terminal Conducted Tests.....</b>	<b>13</b>
<b>APPENDIX 1: Test data .....</b>	<b>14</b>
Conducted Emission .....	14
6 dB Bandwidth and 99 % Occupied Bandwidth.....	16
Maximum Peak Output Power .....	19
Average Output Power .....	20
Radiated Spurious Emission .....	23
Conducted Spurious Emission .....	29
Power Density .....	32
<b>APPENDIX 2: Test instruments .....</b>	<b>34</b>
<b>APPENDIX 3: Photographs of test setup .....</b>	<b>36</b>
Conducted Emission .....	36
Radiated Spurious Emission .....	37
Pre-check of Worst Case Position.....	38

## **SECTION 1: Customer information**

Company Name : Telepower Inc.  
Address : 2-11-9 #3F, Minamiikebukuro, Toshima-ku, Tokyo, 171-0022, Japan  
Telephone Number : +81-3-6907-8511  
Facsimile Number : +81-3-6907-8512  
Contact Person : Hiroshi Ohuchi

The information provided from the customer is as follows;

- Applicant, Type of Equipment, Model No., FCC ID on the cover and other relevant pages
- SECTION 1: Customer information
- SECTION 2: Equipment under test (E.U.T.)
- SECTION 4: Operation of E.U.T. during testing

\* The laboratory is exempted from liability of any test results affected from the above information in SECTION 2 and 4.

## **SECTION 2: Equipment under test (E.U.T.)**

### **2.1 Identification of E.U.T.**

Type of Equipment : BLE module  
Model No. : MTBLE-01  
Serial No. : Refer to SECTION 4.2  
Rating : DC 3.3 V (DC 2 V – 3.45 V)  
Receipt Date of Sample : May 8, 2019  
(Information from test lab.)  
Country of Mass-production : Japan  
Condition of EUT : Production prototype  
(Not for Sale: This sample is equivalent to mass-produced items.)  
Modification of EUT : No Modification by the test lab

### **2.2 Product Description**

Model: MTBLE-01 (referred to as the EUT in this report) is a BLE module.

## **Radio Specification**

### **Bluetooth Low Energy**

Radio Type : Transceiver  
Frequency of Operation : 2402 MHz - 2480 MHz  
Modulation : 2-GFSK  
Antenna type : Chip Antenna  
Antenna Gain : 2.5 dBi  
Clock frequency (Maximum) : 24 MHz

---

**UL Japan, Inc.**

**Shonan EMC Lab.**

1-22-3 Megumigaoka, Hiratsuka-shi, Kanagawa-ken, 259-1220 JAPAN

Telephone : +81 463 50 6400

Facsimile : +81 463 50 6401

## **SECTION 3: Test specification, procedures & results**

### **3.1 Test Specification**

Test Specification : FCC Part 15 Subpart C  
FCC Part 15 final revised on March 12, 2018 and effective April 11, 2018

Title : FCC 47CFR Part15 Radio Frequency Device Subpart C Intentional Radiators  
Section 15.207 Conducted limits  
Section 15.247 Operation within the bands 902 MHz - 928 MHz,  
2400 MHz - 2483.5 MHz, and 5725 MHz - 5850 MHz

### **3.2 Procedures and results**

Item	Test Procedure	Specification	Worst margin	Results	Remarks
Conducted Emission	FCC: ANSI C63.10-2013 6. Standard test methods ----- IC: RSS-Gen 8.8	FCC: Section 15.207 ----- IC: RSS-Gen 8.8	<b>28.8 dB</b> 0.24833 MHz, QP, L1, Tx BT LE 2402 MHz	Complied a)	-
6 dB Bandwidth	FCC: KDB 558074 D01 15.247 Meas Guidance v05r02 ----- IC: -	FCC: Section 15.247(a)(2) ----- IC: RSS-247 5.2(a)	See data.	Complied b)	Conducted
Maximum Peak Output Power	FCC: KDB 558074 D01 15.247 Meas Guidance v05r02 ----- IC: RSS-Gen 6.12	FCC: Section 15.247(b)(3) ----- IC: RSS-247 5.4(d)		Complied c)	Conducted
Power Density	FCC: KDB 558074 D01 15.247 Meas Guidance v05r02 ----- IC: -	FCC: Section 15.247(e) ----- IC: RSS-247 5.2(b)		Complied d)	Conducted
Spurious Emission Restricted Band Edges	FCC: KDB 558074 D01 15.247 Meas Guidance v05r02 ----- IC: RSS-Gen 6.13	FCC: Section15.247(d) ----- IC: RSS-247 5.5 RSS-Gen 8.9 RSS-Gen 8.10		<b>5.4 dB</b> 4804.000 MHz, PK /w AV factor, Hori. Tx BT LE 2402 MHz	Complied e), f)
<p>Note: UL Japan, Inc.'s EMI Work Procedures No. 13-EM-W0420 and 13-EM-W0422.  *1) Radiated test was selected over 30 MHz based on section 15.247(d) and KDB 558074 D01 15.247 Meas Guidance v05r02 8.5 and 8.6.</p> <p>a) Refer to APPENDIX 1 (data of Conducted Emission)  b) Refer to APPENDIX 1 (data of 6 dB Bandwidth and 99 % Occupied Bandwidth)  c) Refer to APPENDIX 1 (data of Maximum Peak Output Power)  d) Refer to APPENDIX 1 (data of Power Density)  e) Refer to APPENDIX 1 (data of Conducted Spurious Emission)  f) Refer to APPENDIX 1 (data of Radiated Spurious Emission)</p> <p>Symbols:  Complied The data of this test item has enough margin, more than the measurement uncertainty.  Complied# The data of this test item meets the limits unless the measurement uncertainty is taken into consideration.</p> <p>* In case any questions arise about test procedure, ANSI C63.10: 2013 is also referred.</p>					

#### **FCC Part 15.31 (e)**

The RF Module has its own regulator. The RF Module is constantly provided voltage through the regulator regardless of input voltage. Therefore, this EUT complies with the requirement.

#### **FCC Part 15.203 Antenna requirement**

The antenna is not removable from the EUT. Therefore the equipment complies with the requirement.

**UL Japan, Inc.**

**Shonan EMC Lab.**

1-22-3 Megumigaoka, Hiratsuka-shi, Kanagawa-ken, 259-1220 JAPAN

Telephone : +81 463 50 6400

Facsimile : +81 463 50 6401

### 3.3 Addition to standard

Item	Test Procedure	Specification	Worst margin	Results	Remarks
99 % Occupied Bandwidth	RSS-Gen 6.7	IC: -	N/A	- a)	Conducted
a) Refer to APPENDIX 1 (data of 6 dB Bandwidth and 99 % Occupied Bandwidth)					

Other than above, no addition, exclusion nor deviation has been made from the standard.

### 3.4 Uncertainty

#### EMI

There is no applicable rule of uncertainty in this applied standard. Therefore, the results are derived depending on whether or not laboratory uncertainty is applied.

The following uncertainties have been calculated to provide a confidence level of 95 % using a coverage factor  $k=2$ .  
Shonan EMC Lab.

Item	Frequency range	Uncertainty (+/-)			
		No. 1 SAC / SR	No. 2 SAC / SR	No. 3 SAC / SR	No. 4 SAC / SR
Conducted emission (AC Mains) LISN	150 kHz-30 MHz	2.9 dB	2.8 dB	2.9 dB	2.9 dB
Radiated emission (Measurement distance: 3 m)	9 kHz-30 MHz	3.0 dB	3.0 dB	3.1 dB	-
	30 MHz-200 MHz	4.6 dB	4.6 dB	4.7 dB	-
	200 MHz-1 GHz	6.0 dB	6.0 dB	6.1 dB	-
	1 GHz-6 GHz	4.8 dB	4.8 dB	4.8 dB	-
	6 GHz-18 GHz	5.4 dB	5.4 dB	5.4 dB	-
	18 GHz-40 GHz	5.6 dB	5.6 dB	5.6 dB	-
Radiated emission (Measurement distance: 1 m)	1 GHz-18 GHz	5.7 dB	5.7 dB	5.7 dB	-
	18 GHz-40 GHz	5.9 dB	5.9 dB	5.9 dB	-

SAC=Semi-Anechoic Chamber

SR= Shielded Room is applied besides radiated emission

Antenna terminal test	Uncertainty (+/-)
Power Measurement above 1 GHz (Average Detector)_SPM-06	0.81 dB
Power Measurement above 1 GHz (Peak Detector)_SPM-06	1.53 dB
Power Measurement above 1 GHz (Average Detector)_SPM-07	0.95 dB
Power Measurement above 1 GHz (Peak Detector)_SPM-07	1.21 dB
Power Measurement above 1 GHz (Average Detector)_SPM-13	0.90 dB
Power Measurement above 1 GHz (Peak Detector)_SPM-13	1.04 dB
Spurious emission (Conducted) below 1GHz	1.8 dB
Spurious emission (Conducted) 1 GHz-3 GHz	1.7 dB
Spurious emission (Conducted) 3 GHz-18 GHz	2.3 dB
Spurious emission (Conducted) 18 GHz-26.5 GHz	2.4 dB
Spurious emission (Conducted) 26.5 GHz-40 GHz	2.4 dB
Bandwidth Measurement	0.61 %
Duty cycle and Time Measurement	0.012 %

**UL Japan, Inc.**

**Shonan EMC Lab.**

1-22-3 Megumigaoka, Hiratsuka-shi, Kanagawa-ken, 259-1220 JAPAN

Telephone : +81 463 50 6400

Facsimile : +81 463 50 6401

### 3.5 Test Location

UL Japan, Inc. Shonan EMC Lab.  
1-22-3, Megumigaoka, Hiratsuka-shi, Kanagawa-ken 259-1220 JAPAN  
Telephone: +81 463 50 6400, Facsimile: +81 463 50 6401  
A2LA Certificate Number: 1266.03  
FCC Test Firm Registration Number: 626366

Test site	IC Registration Number	Width x Depth x Height (m)	Size of reference ground plane (m) / horizontal conducting plane	Maximum measurement distance
No.1 Semi-anechoic chamber	2973D-1	20.6 x 11.3 x 7.65	20.6 x 11.3	10 m
No.2 Semi-anechoic chamber	2973D-2	20.6 x 11.3 x 7.65	20.6 x 11.3	10 m
No.3 Semi-anechoic chamber	2973D-3	12.7 x 7.7 x 5.35	12.7 x 7.7	5 m
No.4 Semi-anechoic chamber	-	8.1 x 5.1 x 3.55	8.1 x 5.1	-
No.1 Shielded room	-	6.8 x 4.1 x 2.7	6.8 x 4.1	-
No.2 Shielded room	-	6.8 x 4.1 x 2.7	6.8 x 4.1	-
No.3 Shielded room	-	6.3 x 4.7 x 2.7	6.3 x 4.7	-
No.4 Shielded room	-	4.4 x 4.7 x 2.7	4.4 x 4.7	-
No.5 Shielded room	-	7.8 x 6.4 x 2.7	7.8 x 6.4	-
No.6 Shielded room	-	7.8 x 6.4 x 2.7	7.8 x 6.4	-
No.8 shielded room	-	3.45 x 5.5 x 2.4	3.45 x 5.5	-
No.1 Measurement room	-	2.55 x 4.1 x 2.5	-	-

### 3.6 Test data, Test instruments, and Test set up

Refer to APPENDIX.

## **SECTION 4: Operation of E.U.T. during testing**

### **4.1 Operating Mode(s)**

<b>Mode</b>	<b>Frequency</b>	<b>Remarks*</b>
Bluetooth Low Energy (BT LE)	2402 MHz 2440 MHz 2480 MHz	PRBS9
<p>*Transmitting duty was 100 % on all tests. *Power of the EUT was set by the software as follows; - Power Setting: Fixed - Software: BTool Version: 1.41.11 *This setting of software is the worst case. Any conditions under the normal use do not exceed the condition of setting. In addition, end users cannot change the settings of the output power of the product.</p>		



## 4.2 Configuration and peripherals

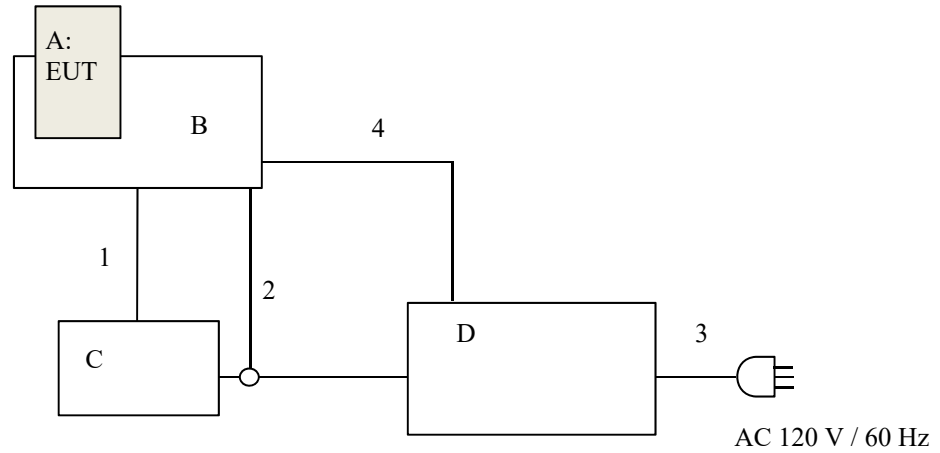

\* Cabling and setup(s) were taken into consideration and test data was taken under worse case conditions.

### Description of EUT and support equipment

No.	Item	Model number	Serial number	Manufacturer	Remarks
A	BLE module	MTBLE-01	002 *1) 001 *2)	Telepower	EUT
B	Jig	-	-	Telepower	*3)
C	Jig	-	-	Telepower	-
D	Power Supply(DC)	PAN35-10A	DE001677	Kikusui	-

\*1) Used for Antenna Terminal conducted test

\*2) Used for Conducted Emission test and Radiated Emission test

\*3) The test was performed with the module that as normal assumed implementation conditions.  
The use of a jig does not influence on the test result.

### List of cables used

No.	Name	Length (m)	Shield		Remarks
			Cable	Connector	
1	Signal	0.5	Unshielded	Unshielded	-
2	DC(-)	0.5 + 1.5	Unshielded	Unshielded	-
3	AC	2.0	Unshielded	Unshielded	-
4	DC(+)	0.5 + 1.5	Unshielded	Unshielded	-

**UL Japan, Inc.**

**Shonan EMC Lab.**

1-22-3 Megumigaoka, Hiratsuka-shi, Kanagawa-ken, 259-1220 JAPAN

Telephone : +81 463 50 6400

Facsimile : +81 463 50 6401

## **SECTION 5: Conducted Emission**

### **Test Procedure and conditions**

EUT was placed on a urethane platform of nominal size, 1.0 m by 1.5 m, raised 0.8 m above the conducting ground plane.

The rear of tabletop was located 40 cm to the vertical conducting plane. The rear of EUT, including peripherals aligned and flushed with rear of tabletop. All other surfaces of tabletop were at least 80 cm from any other grounded conducting surface. EUT was located 80 cm from a Line Impedance Stabilization Network (LISN) / Artificial mains Network (AMN) and excess AC cable was bundled in center.

I/O cables that were connected to the peripherals were bundled in center. They were folded back and forth forming a bundle 30 cm to 40 cm long and were hanged at a 40 cm height to the ground plane.

The AC Mains Terminal Continuous disturbance Voltage has been measured with the EUT via DC power supply in a Shielded Room.

The EUT via DC power supply was connected to a LISN (AMN).

An overview sweep with peak detection has been performed.

The test results and limit are rounded off to one decimal place, so some differences might be observed.

**Detector** : QP and CISPR AV  
**Measurement range** : 0.15 MHz - 30 MHz  
**Test data** : APPENDIX  
**Test result** : Pass

**Figure 1: Test Setup**

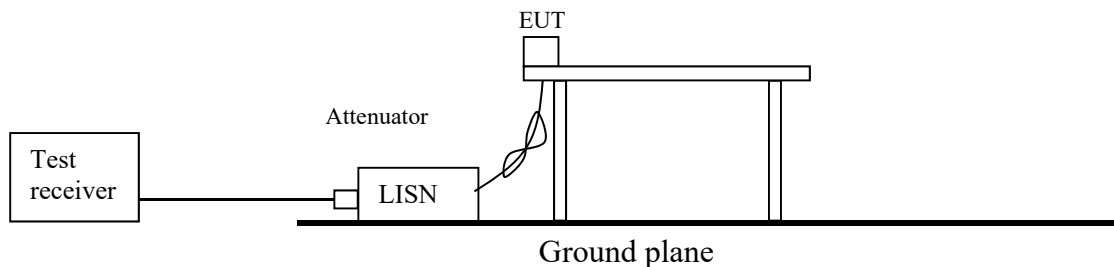

## **SECTION 6: Radiated Spurious Emission**

### **Test Procedure**

It was measured based on "8.5 and 8.6 of KDB 558074 D01 15.247 Meas Guidance v05r02".

[For below 1 GHz]

EUT was placed on a urethane platform of nominal size, 0.5 m by 1.5 m, raised 0.8 m above the conducting ground plane. The Radiated Electric Field Strength has been measured in a Semi Anechoic Chamber with a ground plane.

[For above 1 GHz]

EUT was placed on a urethane platform of nominal size, 0.5 m by 0.5 m, raised 1.5 m above the conducting ground plane.

The Radiated Electric Field Strength has been measured in a Semi Anechoic Chamber with absorbent materials lined on a ground plane.

The height of the measuring antenna varied between 1 and 4 m and EUT was rotated a full revolution in order to obtain the maximum value of the electric field strength.

Test antenna was aimed at the EUT for receiving the maximum signal and always kept within the illumination area of the 3 dB beamwidth of the antenna.

The measurements were performed for both vertical and horizontal antenna polarization with the Test Receiver, or the Spectrum Analyzer.

The measurements were made with the following detector function of the test receiver and the Spectrum analyzer (in linear mode).

The test was made with the detector (RBW/VBW) in the following table.

When using Spectrum analyzer, the test was made with adjusting span to zero by using peak hold.

#### **Test Antennas are used as below;**

Frequency	30 MHz to 200 MHz	200 MHz to 1 GHz	Above 1 GHz
Antenna Type	Biconical	Logperiodic	Horn

In any 100 kHz bandwidth outside the restricted band in which the spread spectrum intentional radiator is operating, the radio frequency power that is produced by the intentional radiator confirmed 20 dB below that in the 100 kHz bandwidth within the band that contains the highest level of the desired power, based on a radiated measurement.

#### **20 dBc was applied to the frequency over the limit of FCC 15.209 / Table 4 of RSS-Gen 8.9(IC) and outside the restricted band of FCC15.205 / Table 6 of RSS-Gen 8.10 (IC).**

Frequency	Below 1 GHz	Above 1 GHz		20 dBc
Instrument used	Test Receiver	Spectrum Analyzer		Spectrum Analyzer
Detector	QP	PK	AV *1)	PK
IF Bandwidth	BW 120 kHz	RBW: 1 MHz VBW: 3 MHz	-	RBW: 100 kHz VBW: 300 kHz

\*1) Measurement with Average detector was not performed. The limit for Average detector is applied to the measurement value with Peak detector used Averaging factor (Duty factor)

**Figure 2: Test Setup**

Below 1 GHz

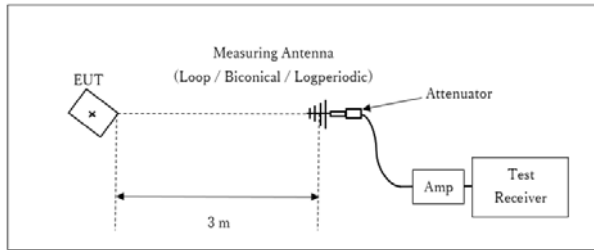

× : Center of turn table

Test Distance: 3 m

1 GHz - 13 GHz

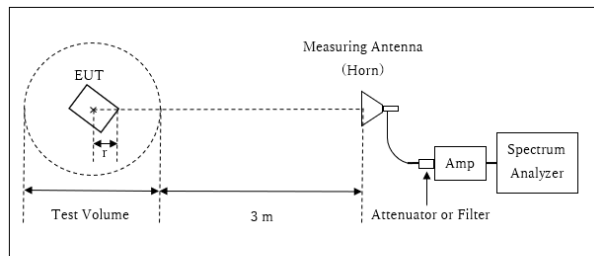

r : Radius of an outer periphery of EUT  
× : Center of turn table

Distance Factor:  $20 \times \log (3.99 \text{ m} / 3.0 \text{ m}) = 2.48 \text{ dB}$

\* Test Distance:  $(3 + \text{Test Volume} / 2) - r = 3.99 \text{ m}$

Test Volume : 2.0 m

(Test Volume has been calibrated based on CISPR 16-1-4.)

r = 0.01 m

13 GHz - 26.5 GHz

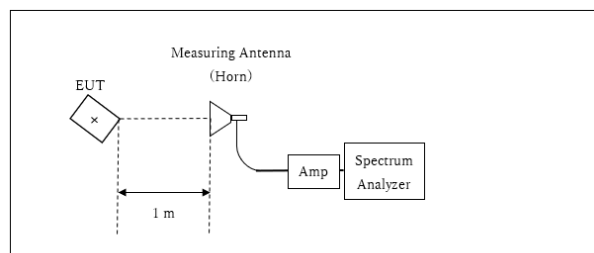

× : Center of turn table

Distance Factor:  $20 \times \log (1.0 \text{ m} / 3.0 \text{ m}) = -9.54 \text{ dB}$

\*Test Distance: 1 m

- The carrier level and noise levels were confirmed at each position of X, Y and Z axes of EUT to see the position of maximum noise, and the test was made at the position that has the maximum noise.

Frequency / Test Antenna	Carrier	Spurious				
		30 MHz-1 GHz	1 GHz -2.8 GHz	2.8 GHz -13 GHz	13 GHz -18 GHz	18 GHz -26.5 GHz
Horizontal	X	X	X	X	X	X
Vertical	Y	X	Y	Z	X	X

The test results and limit are rounded off to one decimal place, so some differences might be observed.

**Measurement range** : 30 MHz - 26.5 GHz

**Test data** : APPENDIX

**Test result** : Pass

**UL Japan, Inc.**

**Shonan EMC Lab.**

1-22-3 Megumigaoka, Hiratsuka-shi, Kanagawa-ken, 259-1220 JAPAN

Telephone : +81 463 50 6400

Facsimile : +81 463 50 6401

## **SECTION 7: Antenna Terminal Conducted Tests**

### **Test Procedure**

The tests were made with below setting connected to the antenna port.

Test	Span	RBW	VBW	Sweep time	Detector	Trace	Instrument used
6 dB Bandwidth	10 MHz	100 kHz	300 kHz	Auto	Peak	Max Hold	Spectrum Analyzer
99 % Occupied Bandwidth *1)	Enough width to display emission skirts	1 to 5 % of OBW	Three times of RBW	Auto	Peak	Max Hold	Spectrum Analyzer
Maximum Peak Output Power	-	-	-	Auto	Peak/Average *2)	-	Power Meter (Sensor: 160 MHz BW)
Peak Power Density	1.5 times the 6 dB Bandwidth	3 kHz	9.1 kHz	Auto	Peak	Max Hold	Spectrum Analyzer *3)
Conducted Spurious Emission *4)	9 kHz to 150 kHz	200 Hz	620 Hz	Auto	Peak	Max Hold	Spectrum Analyzer
	150 kHz to 30 MHz	10 kHz	30 kHz				
*1) Peak hold was applied as Worst-case measurement. *2) Reference data *3) Section 11.10.2 Method PKPSD (peak PSD) of "ANSI C63.10-2013". *4) In the frequency range below 30MHz, RBW was narrowed to separate the noise contents. Then, wide-band noise near the limit was checked separately, however the noise was not detected as shown in the chart. (9 kHz - 150 kHz: RBW = 200 Hz, 150 kHz - 30 MHz: RBW = 10 kHz)							

The test results and limit are rounded off to two decimals place, so some differences might be observed.  
The equipment and cables were not used for factor 0 dB of the data sheets.

**Test data** : APPENDIX  
**Test result** : Pass

**APPENDIX 1: Test data**

**Conducted Emission**

**DATA OF CONDUCTED EMISSION TEST**

UL Japan, Inc. Shonan EMC Lab. No.2 Shielded Room  
Date : 2019/05/15

Mode : Tx BT LE 2402 MHz  
Power : DC 3.3 V  
Temp./Humi. : 22 deg.C / 42 %RH

Limit : FCC\_Part 15 Subpart C(15.207)

Engineer : Hiromasa Sato

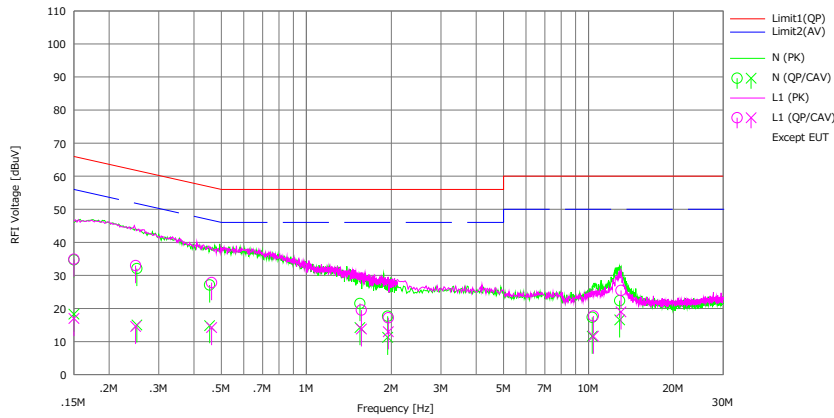

No.	Freq. [MHz]	Reading		C.Fac	Results		Limit		Margin		Phase	Comment
		(QP) [dBuV]	(CAV) [dBuV]		(QP) [dBuV]	(CAV) [dBuV]	(QP) [dBuV]	(AV) [dBuV]	(QP) [dB]	(AV) [dB]		
1	0.15000	22.20	5.80	12.49	34.69	18.29	66.00	56.00	31.3	37.7	N	
2	0.25085	19.60	2.50	12.48	32.08	14.98	61.73	51.73	29.6	36.7	N	
3	0.45420	14.60	2.30	12.51	27.11	14.81	56.80	46.80	29.6	31.9	N	
4	1.54890	8.90	1.60	12.61	21.51	14.21	56.00	46.00	34.4	31.7	N	
5	1.94297	5.00	-1.40	12.66	17.66	11.26	56.00	46.00	38.3	34.7	N	
6	10.31257	4.20	-1.50	13.12	17.32	11.62	60.00	50.00	42.6	38.3	N	
7	12.90420	9.10	3.30	13.25	22.35	16.55	60.00	50.00	37.6	33.4	N	
8	0.15000	22.40	4.50	12.49	34.89	16.99	66.00	56.00	31.1	39.0	L1	
9	0.24833	20.50	2.10	12.48	32.98	14.58	61.81	51.81	28.8	37.2	L1	
10	0.46154	15.30	1.70	12.52	27.82	14.22	56.66	46.66	28.8	32.4	L1	
11	1.56725	6.90	1.20	12.61	19.51	13.81	56.00	46.00	36.4	32.1	L1	
12	1.95250	4.50	0.30	12.66	17.16	12.96	56.00	46.00	38.8	33.0	L1	
13	10.40990	4.60	-1.50	13.12	17.72	11.62	60.00	50.00	42.2	38.3	L1	
14	13.03650	12.20	5.70	13.25	25.45	18.95	60.00	50.00	34.5	31.0	L1	

Calculation: Result[dBuV]=Reading[dBuV] + C.Fac(LISN(AMN) + Cable + ATT)[dB]  
LISN(AMN):SLS-03

## Conducted Emission

Report No.	12858370S-A-R2
Test place	Shonan EMC Lab. No.2 Shielded Room
Date	May 15, 2019
Temperature / Humidity	22 deg. C / 42 % RH
Engineer	Hiromasa Sato
Mode	Tx BT LE

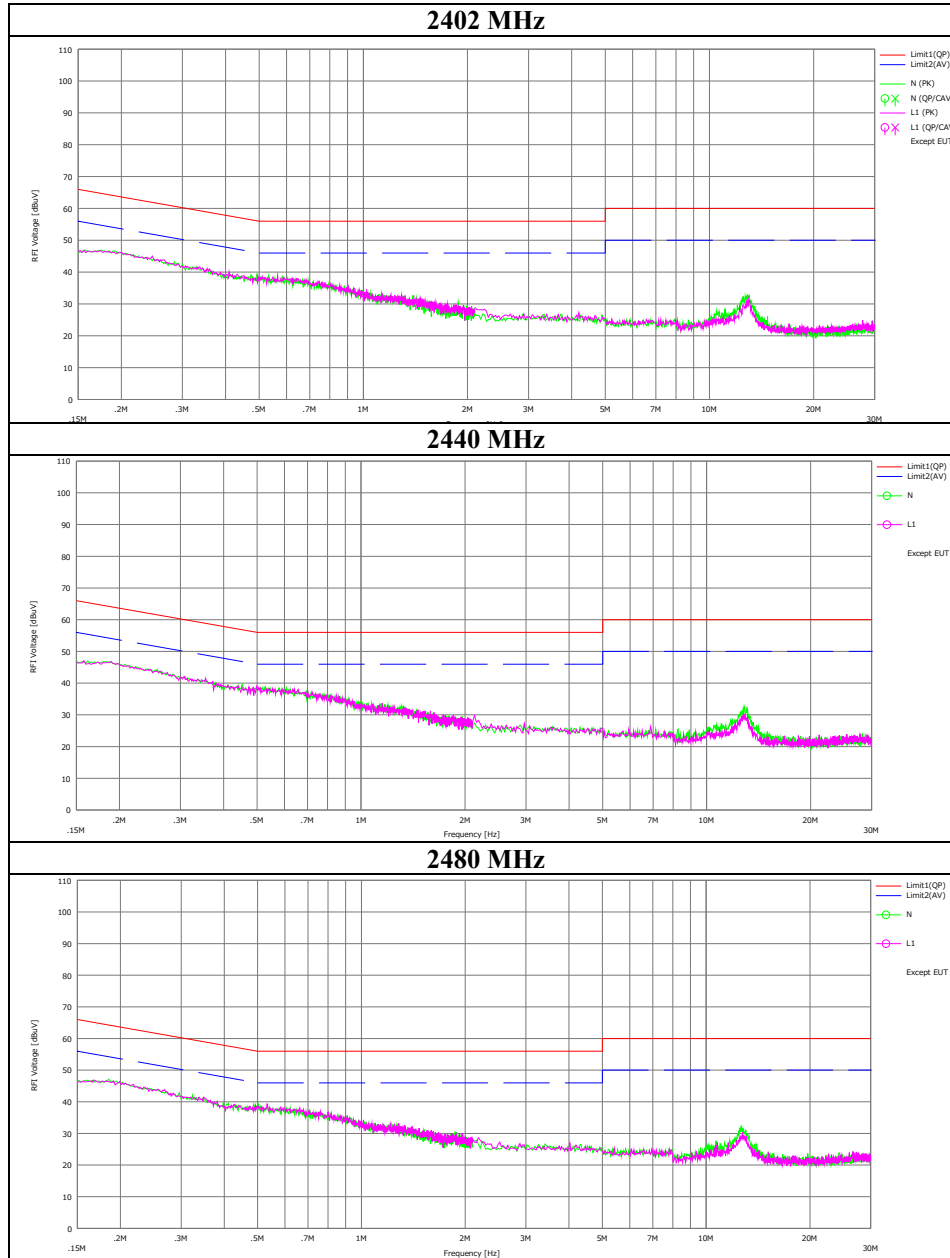

**UL Japan, Inc.**

**Shonan EMC Lab.**

1-22-3 Megumigaoka, Hiratsuka-shi, Kanagawa-ken, 259-1220 JAPAN

Telephone : +81 463 50 6400

Facsimile : +81 463 50 6401

### **6 dB Bandwidth and 99 % Occupied Bandwidth**

Report No. 12858370S-A-R2  
Test place Shonan EMC Lab. No.5 Shielded Room  
Date May 16, 2019  
Temperature / Humidity 26 deg. C / 37 % RH  
Engineer Kazutaka Takeyama  
Mode Tx BT LE

Mode	Frequency [MHz]	99% Occupied Bandwidth [kHz]	6dB Bandwidth [MHz]	Limit for 6dB Bandwidth [MHz]
BT LE	2402	1064.3	0.745	> 0.5000
	2440	1069.2	0.703	> 0.5000
	2480	1064.8	0.761	> 0.5000



## 99%Occupied Bandwidth

### BT LE

#### 2402 MHz

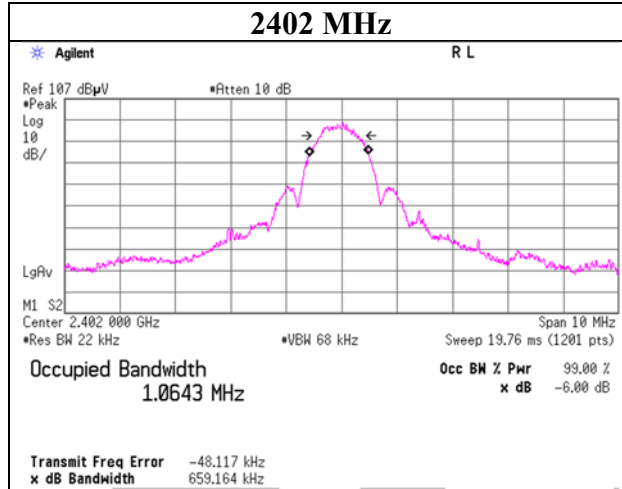

#### 2440 MHz

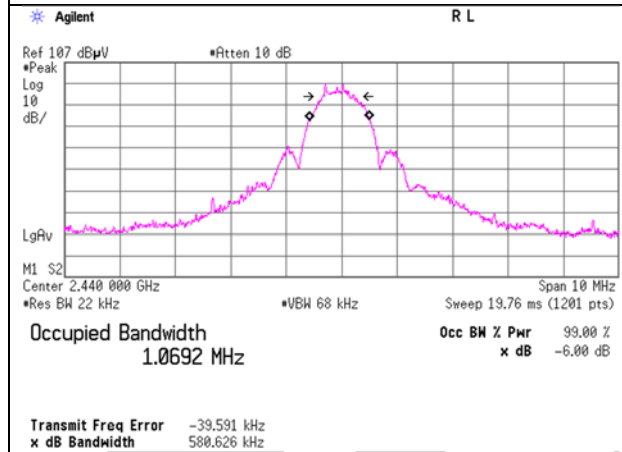

#### 2480 MHz

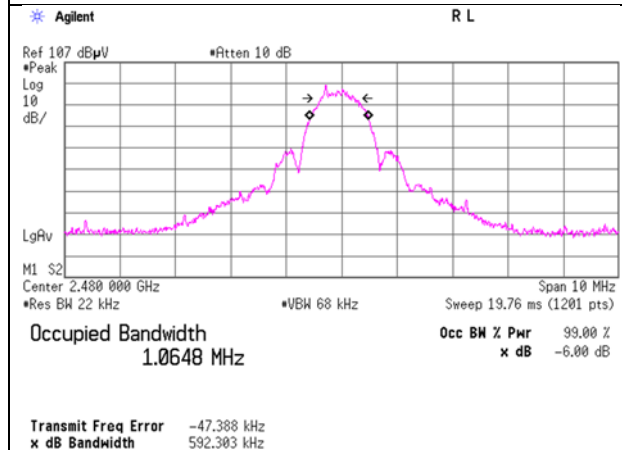

## 6dB Bandwidth

### BT LE

#### 2402 MHz

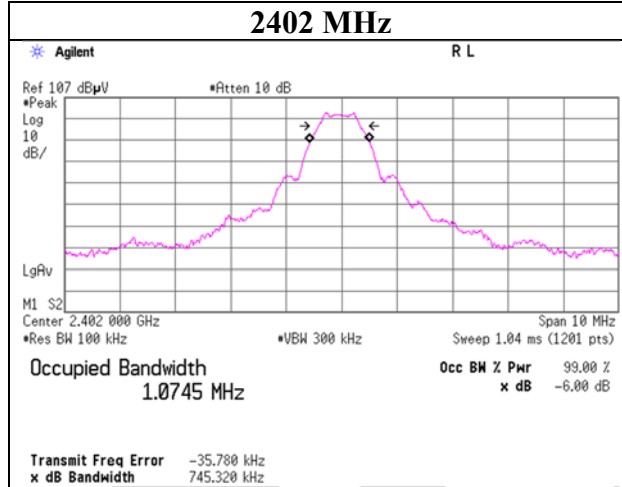

#### 2440 MHz

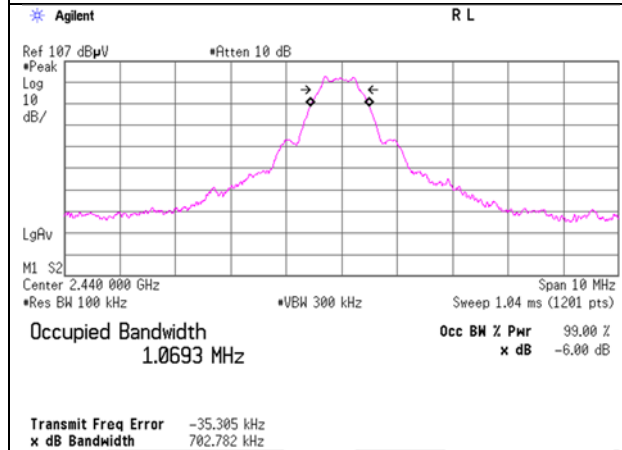

#### 2480 MHz

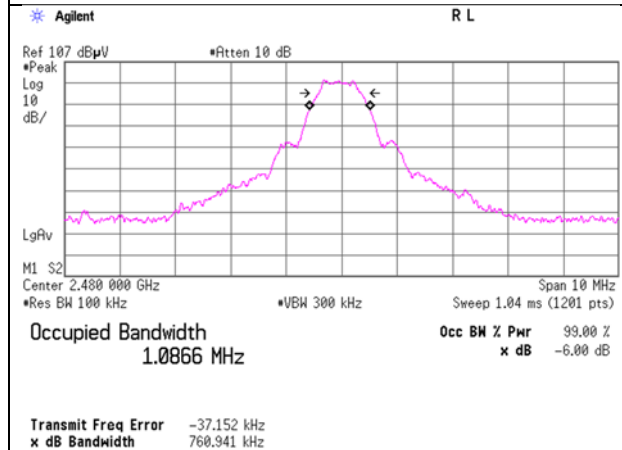

## Maximum Peak Output Power

Report No. 12858370S-A-R2  
Test place Shonan EMC Lab. No.5 Shielded Room  
Date May 15, 2019  
Temperature / Humidity 24 deg. C / 46 % RH  
Engineer Takahiro Kawakami  
Mode Tx BT LE

Freq. [MHz]	Reading [dBm]	Cable Loss [dB]	Atten. Loss [dB]	Conducted Power					e.i.r.p. for RSS-247					
				Result		Limit		Margin [dB]	Antenna Gain [dBi]	Result		Limit		Margin [dB]
				[dBm]	[mW]	[dBm]	[mW]			[dBm]	[mW]	[dBm]	[mW]	
2402	-6.65	1.26	9.82	4.43	2.77	30.00	1000	25.57	2.50	6.93	4.93	36.02	4000	29.09
2440	-7.12	1.27	9.82	3.97	2.49	30.00	1000	26.03	2.50	6.47	4.44	36.02	4000	29.55
2480	-7.89	1.28	9.82	3.21	2.09	30.00	1000	26.79	2.50	5.71	3.72	36.02	4000	30.31

Sample Calculation:

Result = Reading + Cable Loss (including the cable(s) customer supplied) + Attenuator Loss

e.i.r.p. Result = Conducted Power Result + Antenna Gain

**UL Japan, Inc.**

**Shonan EMC Lab.**

1-22-3 Megumigaoka, Hiratsuka-shi, Kanagawa-ken, 259-1220 JAPAN

Telephone : +81 463 50 6400

Facsimile : +81 463 50 6401

**Average Output Power**  
**(Reference data for RF Exposure)**

Report No. 12858370S-A-R2  
Test place Shonan EMC Lab. No.5 Shielded Room  
Date May 15, 2019  
Temperature / Humidity 24 deg. C / 46 % RH  
Engineer Takahiro Kawakami  
Mode Tx BT LE

Freq. [MHz]	Reading [dBm]	Cable Loss [dB]	Atten. Loss [dB]	Duty factor [dB]	Result (Time average)	
					[dBm]	[mW]
2402	-6.86	1.26	9.82	-5.33	-1.11	0.77
2440	-7.34	1.27	9.82	-5.33	-1.58	0.70
2480	-8.15	1.28	9.82	-5.33	-2.38	0.58

Sample Calculation:

Result (Time average) = Reading + Cable Loss (including the cable(s) customer supplied) + Attenuator Loss + Duty factor

Although measurement has been conducted with Duty 100 %, but Average output power had been calculated by Time average by considering maximum duty of the product.

Duty factor refer to “Averaging factor (Duty factor) Calculation chart” sheet.

### Burst rate confirmation

Report No. 12858370S-A-R2  
 Test place Shonan EMC Lab. No.5 Shielded Room  
 Date May 16, 2019  
 Temperature / Humidity 26 deg. C / 37 % RH  
 Engineer Kazutaka Takeyama  
 Mode Tx BT LE

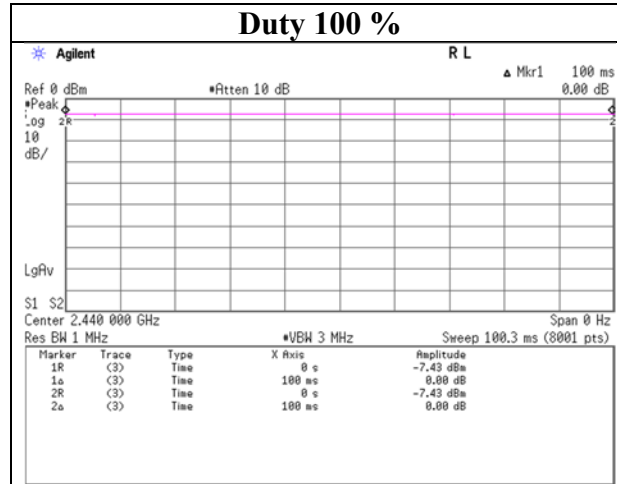

\*Since the burst rate is not different between the channels, the data has been obtained on the representative channel.

**UL Japan, Inc.**

**Shonan EMC Lab.**

1-22-3 Megumigaoka, Hiratsuka-shi, Kanagawa-ken, 259-1220 JAPAN

Telephone : +81 463 50 6400

Facsimile : +81 463 50 6401

### Averaging factor (Duty factor) Calculation chart

The information provided from the customer.

#### (Reference chart)

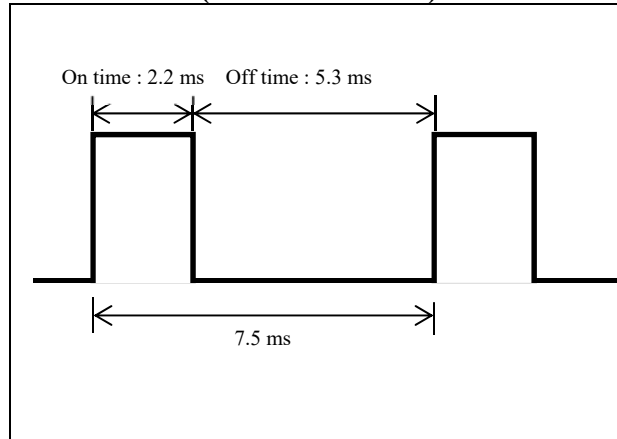

#### (for Average Output Power)

$Tx\ on / (Tx\ on + Tx\ off) =$	0.293
$Tx\ on / (Tx\ on + Tx\ off) * 100 =$	29.3 %
$Duty\ factor = 10 * \log(2.2 / 7.5) =$	-5.33 dB

#### (for Averaging factor for Radiated Spurious Emission) Worst 100 ms case

$Averaging\ factor = 20\log(2.2 \times 14 / 100) = -10.22\ dB$
--

\*Since the burst rate is not different between the channels, the data has been obtained on the representative channel.

\*Worst TX Duty cycle BLE is data communication mode.

The actual measurement value was applied as Averaging factor (Duty Factor).

## Radiated Spurious Emission

Report No.	12858370S-A-R2	
Test place	Shonan EMC Lab.	
Semi Anechoic Chamber	No.2	No.3
Date	May 15, 2019	May 14, 2019
Temperature / Humidity	25 deg. C / 51 % RH	22 deg. C / 42 % RH
Engineer	Hiromasa Sato	Hiromasa Sato
	(30 MHz - 1 GHz)	(1 GHz - 26.5 GHz)
Mode	Tx BT LE 2402 MHz	

(\* PK: Peak, AV: Average, QP: Quasi-Peak)

Polarity	Frequency [MHz]	Detector	Reading [dBuV]	Ant.Fac. [dB/m]	Loss [dB]	Gain [dB]	Distance Factor [dB]	Result [dBuV/m]	Limit [dBuV/m]	Margin [dB]	Height [cm]	Angle [deg]	Remark
Hori.	31.743	QP	23.36	18.04	6.99	31.93	0.00	16.46	40.00	23.5	202	245	
Hori.	194.294	QP	22.87	16.57	9.13	31.80	0.00	16.77	43.50	26.7	154	250	
Hori.	408.898	QP	22.79	15.92	7.61	31.67	0.00	14.65	46.00	31.3	100	219	
Hori.	853.803	QP	22.53	21.55	9.64	31.13	0.00	22.59	46.00	23.4	172	348	
Hori.	2390.000	PK	45.70	27.86	14.15	39.46	2.48	50.73	73.90	23.1	148	54	
Hori.	4804.000	PK	57.79	31.43	6.45	39.50	2.48	58.65	73.90	15.2	157	16	
Hori.	7206.000	PK	48.85	36.79	8.13	39.29	2.48	56.96	73.90	16.9	273	113	
Vert.	34.800	QP	23.63	16.87	7.04	31.93	0.00	15.61	40.00	24.3	120	232	
Vert.	128.997	QP	33.11	13.97	8.37	31.86	0.00	23.59	43.50	19.9	103	183	
Vert.	158.998	QP	28.44	15.11	8.73	31.83	0.00	20.45	43.50	23.0	101	354	
Vert.	462.175	QP	22.81	16.87	7.94	31.64	0.00	15.98	46.00	30.0	100	126	
Vert.	592.889	QP	22.72	19.01	8.49	31.62	0.00	18.60	46.00	27.4	100	356	
Vert.	2390.000	PK	45.12	27.86	14.15	39.46	2.48	50.15	73.90	23.7	178	345	
Vert.	4804.000	PK	56.49	31.43	6.45	39.50	2.48	57.35	73.90	16.5	194	326	
Vert.	7206.000	PK	45.90	36.79	8.13	39.29	2.48	54.01	73.90	19.8	220	308	

Result = Reading + Ant.Fac. + Loss (Cable+(Attenuator or Filter)(below 18 GHz)) - Gain(Amplifier) + Distance factor

Distance factor : 1 GHz - 13 GHz :  $20\log(3.99\text{ m} / 3.0\text{ m}) = 2.48\text{ dB}$

13 GHz - 40 GHz :  $20\log(1.0\text{ m} / 3.0\text{ m}) = -9.54\text{ dB}$

### Peak measurement value with Averaging factor (Duty factor)

Polarity	Frequency [MHz]	Detector	Reading [dBuV]	Ant.Fac. [dB/m]	Loss [dB]	Gain [dB]	Duty Factor [dB]	Distance Factor [dB]	Result [dBuV/m]	Limit [dBuV/m]	Margin [dB]	Remark
Hori.	2390.000	PK	45.70	27.86	14.15	39.46	-10.22	2.48	40.51	53.90	13.3	*1)
Hori.	4804.000	PK	57.79	31.43	6.45	39.50	-10.22	2.48	48.43	53.90	5.4	
Hori.	7206.000	PK	48.85	36.79	8.13	39.29	-10.22	2.48	46.74	53.90	7.1	
Vert.	2390.000	PK	45.12	27.86	14.15	39.46	-10.22	2.48	39.93	53.90	13.9	*1)
Vert.	4804.000	PK	56.49	31.43	6.45	39.50	-10.22	2.48	47.13	53.90	6.7	
Vert.	7206.000	PK	45.90	36.79	8.13	39.29	-10.22	2.48	43.79	53.90	10.1	

Result = Reading + Ant.Fac. + Loss (Cable+(Attenuator or Filter)(below 18 GHz)) - Gain(Amplifier) + Duty factor + Distance factor

Distance factor : 1 GHz - 13 GHz :  $20\log(3.99\text{ m} / 3.0\text{ m}) = 2.48\text{ dB}$

13 GHz - 40 GHz :  $20\log(1.0\text{ m} / 3.0\text{ m}) = -9.54\text{ dB}$

Averaging factor refer to "Averaging factor (Duty factor) Calculation chart" sheet.

\*1) Not out of band emission (Leakage Power)

### 20 dBc Data Sheet (RBW 100 kHz, VBW 300 kHz)

Polarity	Frequency [MHz]	Detector	Reading [dBuV]	Ant.Fac. [dB/m]	Loss [dB]	Gain [dB]	Distance Factor [dB]	Result [dBuV/m]	Limit [dBuV/m]	Margin [dB]	Remark
Hori.	2402.000	PK	85.44	27.86	14.16	39.46	2.48	90.48	-	-	Carrier
Hori.	2400.000	PK	36.29	27.86	14.16	39.46	2.48	41.33	70.48	29.1	
Vert.	2402.000	PK	84.51	27.86	14.16	39.46	2.48	89.55	-	-	Carrier
Vert.	2400.000	PK	35.10	27.86	14.16	39.46	2.48	40.14	69.55	29.4	

Result = Reading + Ant.Fac. + Loss (Cable+(Attenuator or Filter)(below 18 GHz)) - Gain(Amplifier) + Distance factor

Distance factor : 1 GHz - 13 GHz :  $20\log(3.99\text{ m} / 3.0\text{ m}) = 2.48\text{ dB}$

13 GHz - 40 GHz :  $20\log(1.0\text{ m} / 3.0\text{ m}) = -9.54\text{ dB}$

**UL Japan, Inc.**

**Shonan EMC Lab.**

1-22-3 Megumigaoka, Hiratsuka-shi, Kanagawa-ken, 259-1220 JAPAN

Telephone : +81 463 50 6400

Facsimile : +81 463 50 6401

### Radiated Spurious Emission (Reference Plot for band-edge)

Report No. 12858370S-A-R2  
Test place Shonan EMC Lab.  
Semi Anechoic Chamber No.3  
Date May 14, 2019  
Temperature / Humidity 22 deg. C / 42 % RH  
Engineer Hiromasa Sato  
(1 GHz - 26.5 GHz)  
Mode Tx BT LE 2402 MHz

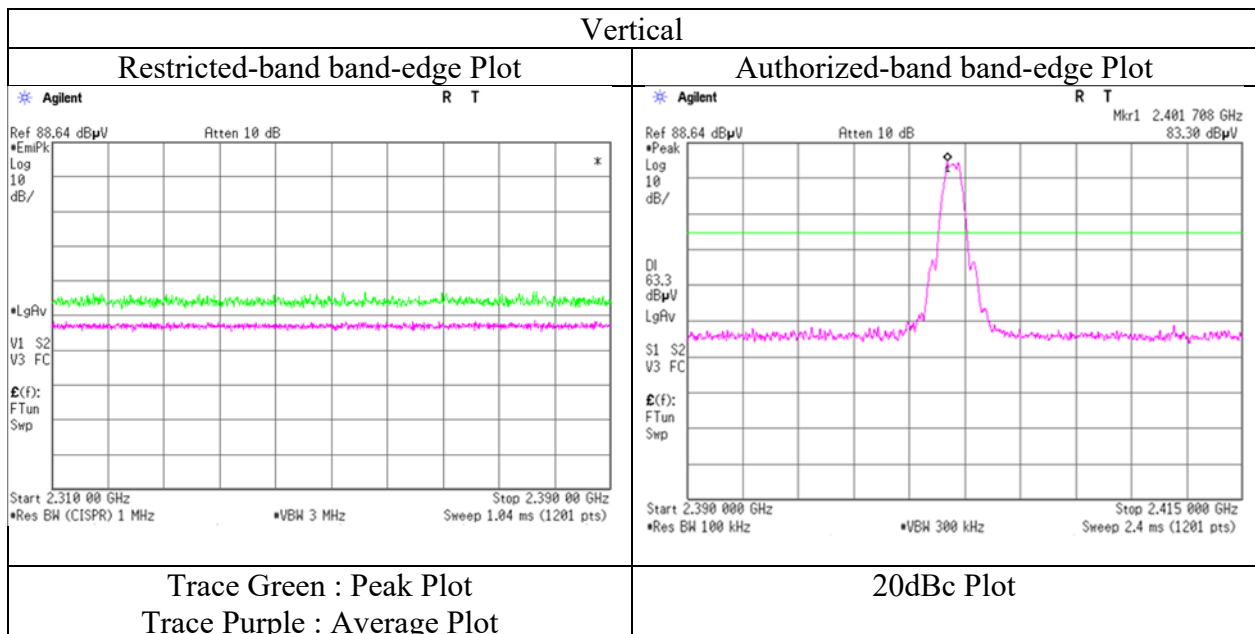
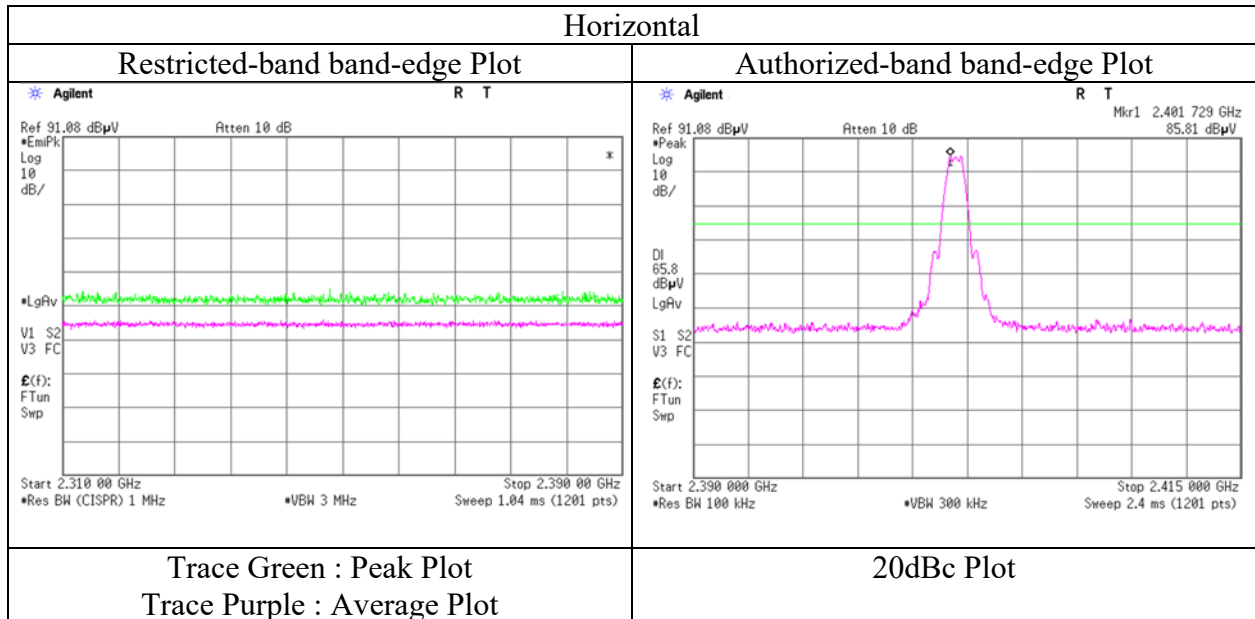

\* The measurement was conducted for a sufficiently long enough time to detect any possible spurious emissions. Final result of restricted band edge was shown in tabular data.



## Radiated Spurious Emission

Report No.	12858370S-A-R2	
Test place	Shonan EMC Lab.	
Semi Anechoic Chamber	No.2	No.3
Date	May 15, 2019	May 14, 2019
Temperature / Humidity	25 deg. C / 51 % RH	22 deg. C / 42 % RH
Engineer	Hiromasa Sato	Hiromasa Sato
	(30 MHz - 1 GHz)	(1 GHz - 26.5 GHz)
Mode	Tx BT LE 2440 MHz	

(\* PK: Peak, AV: Average, QP: Quasi-Peak)

Polarity	Frequency [MHz]	Detector	Reading [dBuV]	Ant.Fac. [dB/m]	Loss [dB]	Gain [dB]	Distance Factor [dB]	Result [dBuV/m]	Limit [dBuV/m]	Margin [dB]	Height [cm]	Angle [deg]	Remark
Hori.	33.460	QP	22.73	17.36	7.02	31.93	0.00	15.18	40.00	24.8	296	216	
Hori.	186.724	QP	22.67	16.22	9.05	31.81	0.00	16.13	43.50	27.3	188	1	
Hori.	434.687	QP	22.53	16.27	7.80	31.66	0.00	14.94	46.00	31.0	128	281	
Hori.	871.047	QP	22.61	21.91	9.72	31.05	0.00	23.19	46.00	22.8	190	37	
Hori.	4880.000	PK	52.28	31.37	6.48	39.50	2.48	53.11	73.90	20.7	123	15	
Hori.	7320.000	PK	47.76	37.00	8.12	39.35	2.48	56.01	73.90	17.8	126	27	
Vert.	41.599	QP	22.52	14.28	7.16	31.92	0.00	12.04	40.00	27.9	340	314	
Vert.	83.998	QP	31.58	6.95	7.80	31.89	0.00	14.44	40.00	25.5	107	194	
Vert.	128.997	QP	33.20	13.97	8.37	31.86	0.00	23.68	43.50	19.8	101	350	
Vert.	191.997	QP	27.13	16.36	9.11	31.81	0.00	20.79	43.50	22.7	102	314	
Vert.	239.996	QP	29.41	11.56	6.20	31.74	0.00	15.43	46.00	30.5	229	197	
Vert.	4880.000	PK	50.59	31.37	6.48	39.50	2.48	51.42	73.90	22.4	159	153	
Vert.	7320.000	PK	46.61	37.00	8.12	39.35	2.48	54.86	73.90	19.0	245	140	

Result = Reading + Ant.Fac. + Loss (Cable+(Attenuator or Filter)(below 18 GHz)) - Gain(Amplifier) + Distance factor

Distance factor : 1 GHz - 13 GHz :  $20\log(3.99\text{ m} / 3.0\text{ m}) = 2.48\text{ dB}$

13 GHz - 40 GHz :  $20\log(1.0\text{ m} / 3.0\text{ m}) = -9.54\text{ dB}$

### Peak measurement value with Averaging factor (Duty factor)

Polarity	Frequency [MHz]	Detector	Reading [dBuV]	Ant.Fac. [dB/m]	Loss [dB]	Gain [dB]	Duty Factor [dB]	Distance Factor [dB]	Result [dBuV/m]	Limit [dBuV/m]	Margin [dB]	Remark
Hori.	4880.000	PK	52.28	31.37	6.48	39.50	-10.22	2.48	42.89	53.90	11.0	
Hori.	7320.000	PK	47.76	37.00	8.12	39.35	-10.22	2.48	45.79	53.90	8.1	
Vert.	4880.000	PK	50.59	31.37	6.48	39.50	-10.22	2.48	41.20	53.90	12.7	
Vert.	7320.000	PK	46.61	37.00	8.12	39.35	-10.22	2.48	44.64	53.90	9.2	

Result = Reading + Ant.Fac. + Loss (Cable+(Attenuator or Filter)(below 18 GHz)) - Gain(Amplifier) + Duty factor + Distance factor

Distance factor : 1 GHz - 13 GHz :  $20\log(3.99\text{ m} / 3.0\text{ m}) = 2.48\text{ dB}$

13 GHz - 40 GHz :  $20\log(1.0\text{ m} / 3.0\text{ m}) = -9.54\text{ dB}$

Averaging factor refer to "Averaging factor (Duty factor) Calculation chart" sheet.

**UL Japan, Inc.**

**Shonan EMC Lab.**

1-22-3 Megumigaoka, Hiratsuka-shi, Kanagawa-ken, 259-1220 JAPAN

Telephone : +81 463 50 6400

Facsimile : +81 463 50 6401

## Radiated Spurious Emission

Report No.	12858370S-A-R2	
Test place	Shonan EMC Lab.	
Semi Anechoic Chamber	No.2	No.3
Date	May 15, 2019	May 14, 2019
Temperature / Humidity	25 deg. C / 51 % RH	22 deg. C / 42 % RH
Engineer	Hiromasa Sato	Hiromasa Sato
	(30 MHz - 1 GHz)	(1 GHz - 26.5 GHz)
Mode	Tx BT LE 2480 MHz	

(\* PK: Peak, AV: Average, QP: Quasi-Peak)

Polarity	Frequency [MHz]	Detector	Reading [dBuV]	Ant.Fac. [dB/m]	Loss [dB]	Gain [dB]	Distance Factor [dB]	Result [dBuV/m]	Limit [dBuV/m]	Margin [dB]	Height [cm]	Angle [deg]	Remark
Hori.	32.197	QP	23.44	17.84	7.00	31.93	0.00	16.35	40.00	23.6	138	171	
Hori.	151.326	QP	22.91	14.89	8.65	31.84	0.00	14.61	43.50	28.8	155	337	
Hori.	488.019	QP	22.68	17.48	8.03	31.63	0.00	16.56	46.00	29.4	194	10	
Hori.	914.058	QP	22.31	22.06	9.91	30.80	0.00	23.48	46.00	22.5	135	105	
Hori.	2483.500	PK	46.73	27.65	14.22	39.46	2.48	51.62	73.90	22.2	196	56	
Hori.	4960.000	PK	50.99	31.54	6.51	39.50	2.48	52.02	73.90	21.8	165	187	
Hori.	7440.000	PK	47.39	37.10	8.12	39.42	2.48	55.67	73.90	18.2	144	24	
Vert.	85.499	QP	29.31	7.29	7.82	31.89	0.00	12.53	40.00	27.4	124	311	
Vert.	130.499	QP	33.32	13.86	8.39	31.86	0.00	23.71	43.50	19.7	104	314	
Vert.	197.996	QP	25.99	16.63	9.18	31.80	0.00	20.00	43.50	23.5	101	295	
Vert.	236.916	QP	22.65	11.49	6.16	31.75	0.00	8.55	46.00	37.4	103	293	
Vert.	771.697	QP	22.54	20.44	9.28	31.42	0.00	20.84	46.00	25.1	121	25	
Vert.	2483.500	PK	46.67	27.65	14.22	39.46	2.48	51.56	73.90	22.3	271	182	
Vert.	4960.000	PK	52.91	31.54	6.51	39.50	2.48	53.94	73.90	19.9	161	119	
Vert.	7440.000	PK	47.37	37.10	8.12	39.42	2.48	55.65	73.90	18.2	163	55	

Result = Reading + Ant.Fac. + Loss (Cable+(Attenuator or Filter)(below 18 GHz)) - Gain(Amplifier) + Distance factor

Distance factor : 1 GHz - 13 GHz : 20log(3.99 m / 3.0 m) = 2.48 dB

13 GHz - 40 GHz : 20log(1.0 m / 3.0 m) = -9.54 dB

### Peak measurement value with Averaging factor (Duty factor)

Polarity	Frequency [MHz]	Detector	Reading [dBuV]	Ant.Fac. [dB/m]	Loss [dB]	Gain [dB]	Duty Factor [dB]	Distance Factor [dB]	Result [dBuV/m]	Limit [dBuV/m]	Margin [dB]	Remark
Hori.	2483.500	PK	46.73	27.65	14.22	39.46	-10.22	2.48	41.40	53.90	12.5	*1)
Hori.	4960.000	PK	50.99	31.54	6.51	39.50	-10.22	2.48	41.80	53.90	12.1	
Hori.	7440.000	PK	47.39	37.10	8.12	39.42	-10.22	2.48	45.45	53.90	8.4	
Vert.	2483.500	PK	46.67	27.65	14.22	39.46	-10.22	2.48	41.34	53.90	12.5	*1)
Vert.	4960.000	PK	52.91	31.54	6.51	39.50	-10.22	2.48	43.72	53.90	10.1	
Vert.	7440.000	PK	47.37	37.10	8.12	39.42	-10.22	2.48	45.43	53.90	8.4	

Result = Reading + Ant.Fac. + Loss (Cable+(Attenuator or Filter)(below 18 GHz)) - Gain(Amplifier) + Duty factor + Distance factor

Distance factor : 1 GHz - 13 GHz : 20log(3.99 m / 3.0 m) = 2.48 dB

13 GHz - 40 GHz : 20log(1.0 m / 3.0 m) = -9.54 dB

Averaging factor refer to "Averaging factor (Duty factor) Calculation chart" sheet.

\*1) Not out of band emission (Leakage Power)

**Radiated Spurious Emission**  
**(Reference Plot for band-edge)**

Report No. 12858370S-A-R2  
Test place Shonan EMC Lab.  
Semi Anechoic Chamber No.3  
Date May 14, 2019  
Temperature / Humidity 22 deg. C / 42 % RH  
Engineer Hiromasa Sato  
(1 GHz - 26.5 GHz)  
Mode Tx BT LE 2480 MHz

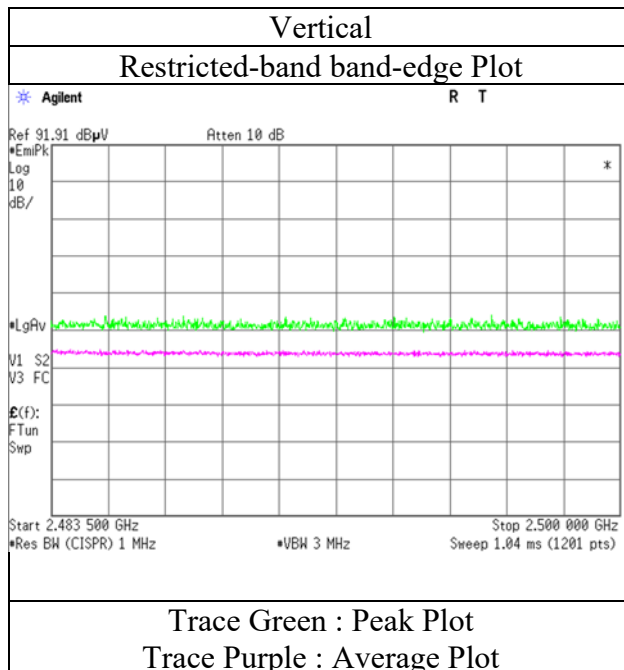
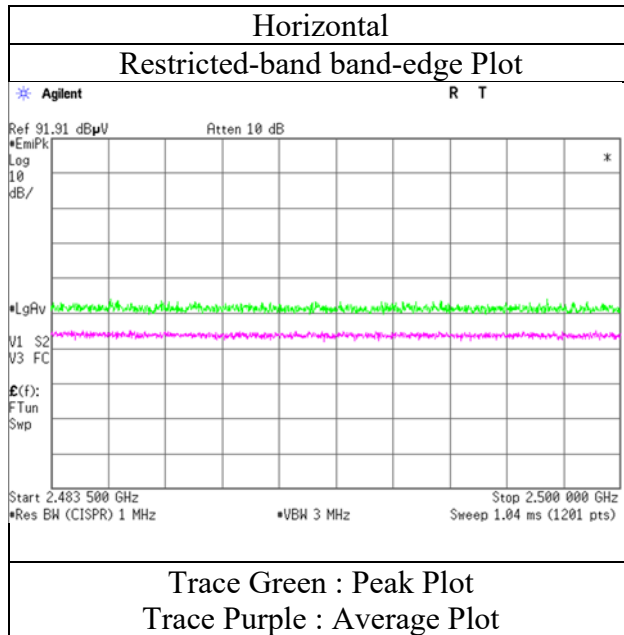

\* The measurement was conducted for a sufficiently long enough time to detect any possible spurious emissions. Final result of restricted band edge was shown in tabular data.

**Radiated Spurious Emission**  
**(Plot data, Worst case)**

Report No.	12858370S-A-R2	No.3
Test place	Shonan EMC Lab.	May 14, 2019
Semi Anechoic Chamber	No.2	May 15, 2019
Date	May 15, 2019	22 deg. C / 42 % RH
Temperature / Humidity	25 deg. C / 51 % RH	22 deg. C / 42 % RH
Engineer	Hiromasa Sato	Hiromasa Sato
	(30 MHz - 1 GHz)	(1 GHz - 26.5 GHz)
Mode	Tx BT LE 2402 MHz	

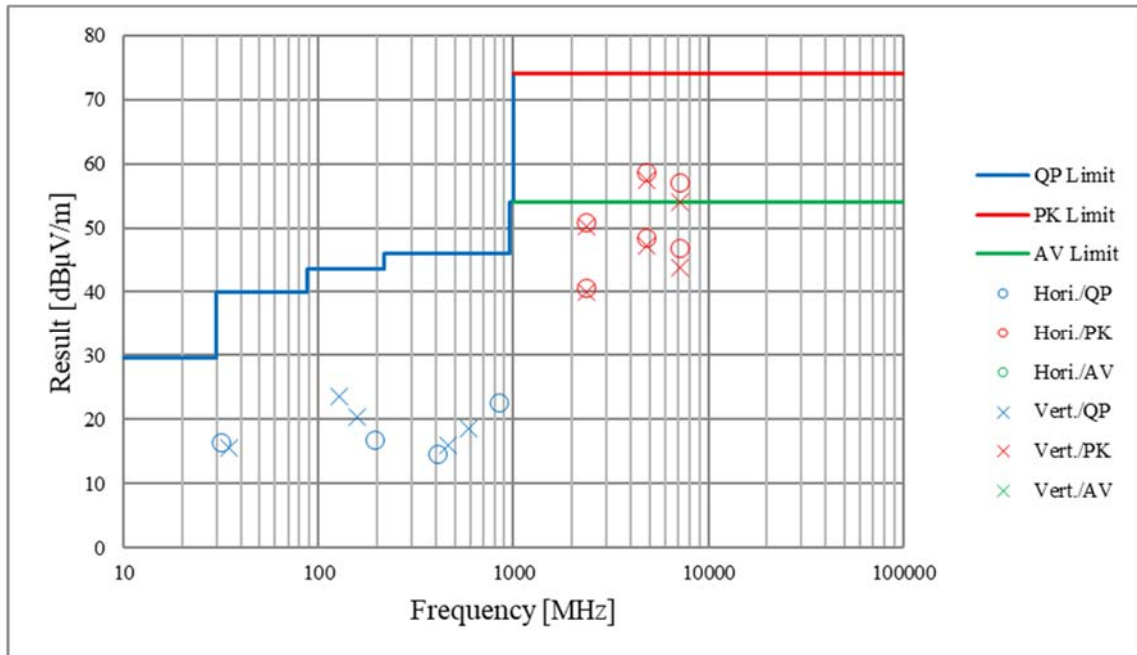

\*These plots data contains sufficient number to show the trend of characteristic features for EUT.

## Conducted Spurious Emission

Report No. 12858370S-A-R2  
Test place Shonan EMC Lab. No.5 Shielded Room  
Date May 16, 2019  
Temperature / Humidity 26 deg. C / 37 % RH  
Engineer Kazutaka Takeyama  
Mode Tx BT LE 2402 MHz

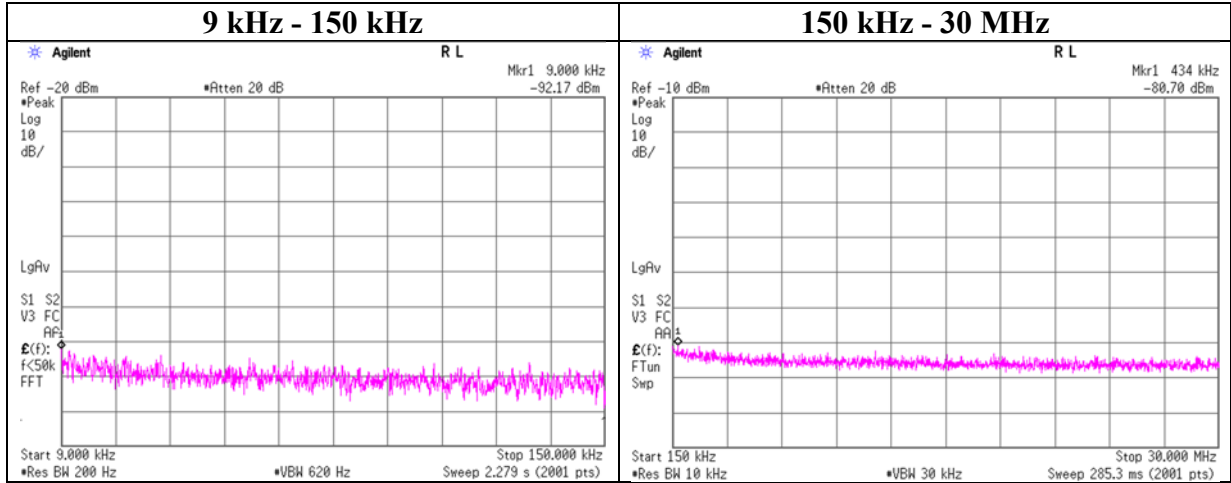

Frequency [kHz]	Reading [dBm]	Cable Loss [dB]	Attenuator Loss [dB]	Antenna Gain [dBi]	N (Number of Output)	EIRP [dBm]	Distance [m]	Ground bounce [dB]	E (field strength) [dBuV/m]	Limit [dBuV/m]	Margin [dB]	Remark
9.00	-92.1	0.01	9.8	2.5	1	-79.8	300	6.0	-18.5	48.5	67.0	
434.00	-80.7	0.01	9.8	2.5	1	-68.4	300	6.0	-7.1	14.8	21.9	

$$E \text{ [dBuV/m]} = \text{EIRP [dBm]} - 20 \log (\text{Distance [m]}) + \text{Ground bounce [dB]} + 104.8 \text{ [dBuV/m]}$$

$$\text{EIRP [dBm]} = \text{Reading [dBm]} + \text{Cable loss [dB]} + \text{Attenuator Loss [dB]} + \text{Antenna gain [dBi]} + 10 * \log (N)$$

N: Number of output

### Conducted Spurious Emission

Report No. 12858370S-A-R2  
Test place Shonan EMC Lab. No.5 Shielded Room  
Date May 16, 2019  
Temperature / Humidity 26 deg. C / 37 % RH  
Engineer Kazutaka Takeyama  
Mode Tx BT LE 2440 MHz

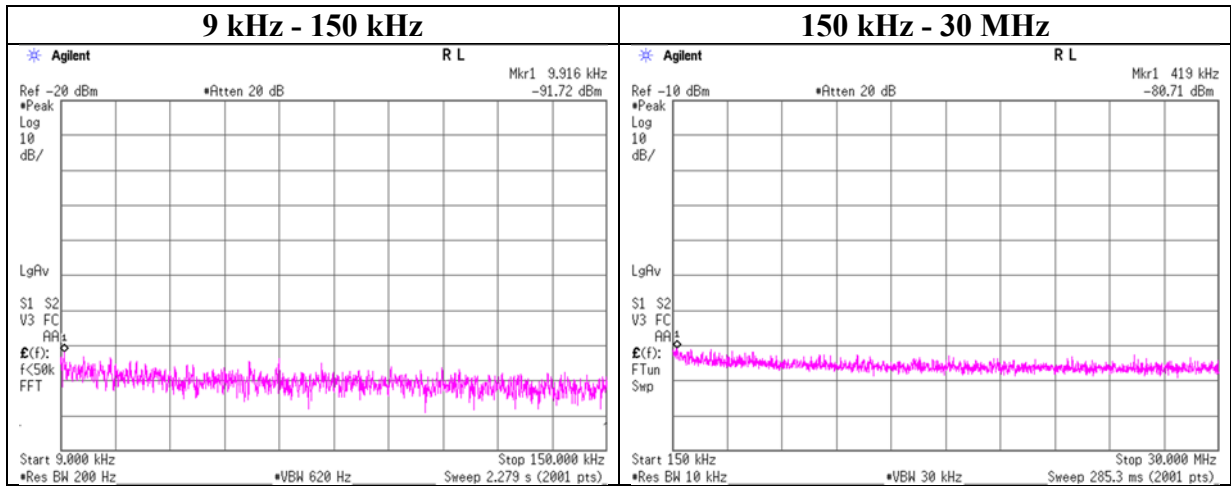

Frequency [kHz]	Reading [dBm]	Cable Loss [dB]	Attenuator Loss [dB]	Antenna Gain [dBi]	N (Number of Output)	EIRP [dBm]	Distance [m]	Ground bounce [dB]	E (field strength) [dBuV/m]	Limit [dBuV/m]	Margin [dB]	Remark
9.92	-91.7	0.01	9.8	2.5	1	-79.4	300	6.0	-18.1	47.6	65.7	
419.00	-80.7	0.01	9.8	2.5	1	-68.4	300	6.0	-7.1	15.1	22.2	

$E \text{ [dBuV/m]} = \text{EIRP [dBm]} - 20 \log(\text{Distance [m]}) + \text{Ground bounce [dB]} + 104.8 \text{ [dBuV/m]}$

$\text{EIRP [dBm]} = \text{Reading [dBm]} + \text{Cable loss [dB]} + \text{Attenuator Loss [dB]} + \text{Antenna gain [dBi]} + 10 * \log(N)$

N: Number of output

## Conducted Spurious Emission

Report No. 12858370S-A-R2  
 Test place Shonan EMC Lab. No.5 Shielded Room  
 Date May 16, 2019  
 Temperature / Humidity 26 deg. C / 37 % RH  
 Engineer Kazutaka Takeyama  
 Mode Tx BT LE 2480 MHz

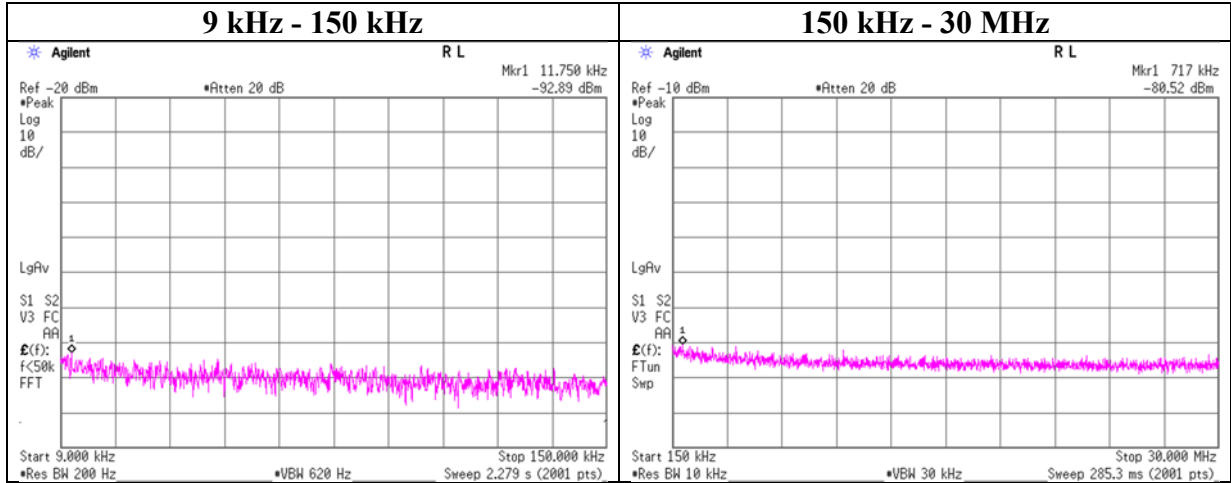

Frequency [kHz]	Reading [dBm]	Cable Loss [dB]	Attenuator Loss [dB]	Antenna Gain [dBi]	N (Number of Output)	EIRP [dBm]	Distance [m]	Ground bounce [dB]	E (field strength) [dBuV/m]	Limit [dBuV/m]	Margin [dB]	Remark
11.75	-92.8	0.01	9.8	2.5	1	-80.5	300	6.0	-19.2	46.2	65.4	
717.00	-80.5	0.01	9.8	2.5	1	-68.2	30	6.0	13.1	30.4	17.3	

$$E \text{ [dBuV/m]} = \text{EIRP [dBm]} - 20 \log(\text{Distance [m]}) + \text{Ground bounce [dB]} + 104.8 \text{ [dBuV/m]}$$

$$\text{EIRP [dBm]} = \text{Reading [dBm]} + \text{Cable loss [dB]} + \text{Attenuator Loss [dB]} + \text{Antenna gain [dBi]} + 10 * \log(N)$$

N: Number of output

**UL Japan, Inc.**

**Shonan EMC Lab.**

1-22-3 Megumigaoka, Hiratsuka-shi, Kanagawa-ken, 259-1220 JAPAN

Telephone : +81 463 50 6400

Facsimile : +81 463 50 6401

### Power Density

Report No. 12858370S-A-R2  
Test place Shonan EMC Lab. No.5 Shielded Room  
Date May 16, 2019  
Temperature / Humidity 26 deg. C / 37 % RH  
Engineer Kazutaka Takeyama  
Mode Tx BT LE

Freq. [MHz]	Reading [dBm]	Cable Loss [dB]	Atten. Loss [dB]	Result [dBm]	Limit [dBm]	Margin [dB]
2402.00	-16.41	1.26	9.82	-5.33	8.00	13.33
2440.00	-17.01	1.27	9.82	-5.92	8.00	13.92
2480.00	-18.06	1.28	9.82	-6.96	8.00	14.96

Sample Calculation:

Result = Reading + Cable Loss (including the cable(s) customer supplied) + Attenuator Loss



## Power Density

### BT LE

#### 2402 MHz

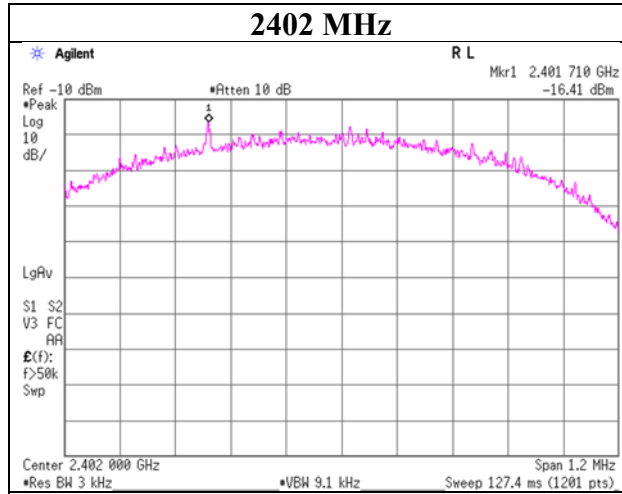

#### 2440 MHz

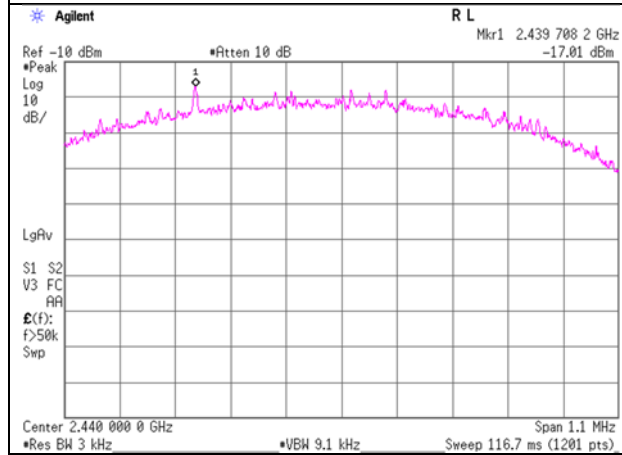

#### 2480 MHz

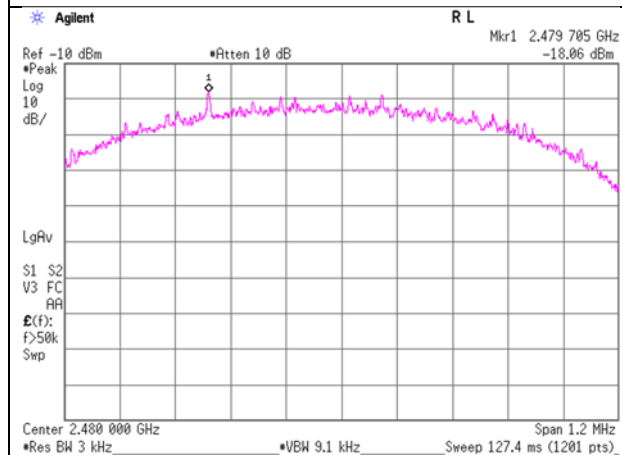

## **APPENDIX 2: Test instruments**

### **Test Instruments (1 / 2)**

Local ID	Test Name	LIMS ID	Description	Manufacturer	Model	Serial	Last Calibration Date	Calibration Due Date	Calibration Interval (Month)
KTS-07	AT	145111	Digital Tester	SANWA	PC500	7019232	2018/10/17	2019/10/31	12
SAT10-13	AT	151610	Attenuator	Weinschel Corp.	54A-10	81626	2019/3/27	2020/3/31	12
SCC-G12	AT	145040	Coaxial Cable	Suhner	SUCOFLEX 102	30790/2	2019/3/27	2020/3/31	12
SOS-19	AT	175823	Humidity Indicator	CUSTOM	CTH-201	-	2018/12/5	2019/12/31	12
SPM-13	AT	169910	Power Meter	KEYSIGHT	8990B	MY51000448	2019/3/6	2020/3/31	12
SPSS-06	AT	169911	Power sensor	KEYSIGHT	N1923A	MY57270004	2019/3/6	2020/3/31	12
SSA-02	AT	145800	Spectrum Analyzer	AGILENT	E4448A	MY48250106	2019/4/4	2020/4/30	12
KAT3-12	CE	144896	Attenuator	JFW IND. INC.	50HF-003N	-	2018/7/13	2019/7/31	12
SCC-B9/B10/B11/B13/SRSE-02	CE	144970	Coaxial Cable&RF Selector	Suhner/Fujikura/Suhner/Suhner/TOYO	RG223U/12D SFA/141PE/N S4906	-/0901-270(RF Selector)	2019/4/19	2020/4/30	12
SLS-03	CE	145540	LISN	Rohde & Schwarz	ENV216	100513	2019/2/21	2020/2/29	12
COTS-SEMI-5	CE,RE	170932	EMI Software	TSJ	TEPTO-DV3(RE,CE, ME,PE)	-	-	-	-
SJM-09	CE,RE	145336	Measure	PROMART	SEN1935	-	-	-	-
SOS-03	CE,RE	146317	Humidity Indicator	A&D	AD-5681	4063325	2018/10/25	2019/10/31	12
STR-07	CE,RE	146209	Test Receiver	Rohde & Schwarz	ESU26	100484	2018/9/26	2019/9/30	12
STS-02	CE,RE	145793	Digital Hitester	HIOKI	3805-50	80997819	2019/4/2	2020/4/30	12
KJM-02	RE	146432	Measure	TAJIMA	GL19-55	-	-	-	-
KSA-08	RE	145089	Spectrum Analyzer	AGILENT	E4446A	MY46180525	2018/10/7	2019/10/31	12
SAEC-02(NSA)	RE	145563	Semi-Anechoic Chamber	TDK	SAEC-02(NSA)	2	2019/4/4	2020/4/30	12
SAEC-03(SVSWR)	RE	145566	Semi-Anechoic Chamber	TDK	SAEC-03(SVSWR)	3	2019/5/3	2020/5/31	12
SAF-02	RE	145004	Pre Amplifier	SONOMA	310N	290212	2019/2/5	2020/2/29	12
SAF-04	RE	145127	Pre Amplifier	Toyo Corporation	TPA0118-36	2072554	2018/6/26	2019/6/30	12
SAF-08	RE	145007	Pre Amplifier	Toyo Corporation	HAP18-26W	19	2019/3/5	2020/3/31	12
SAT10-05	RE	145136	Attenuator(above1GHz)	AGILENT	8493C-010	74864	2018/11/25	2019/11/30	12
SAT3-11	RE	150921	Attenuator	JFW	50HF-003N	-	2019/1/25	2020/1/31	12
SAT6-14	RE	167095	Attenuator	JFW	50HF-006N	-	2019/2/5	2020/2/29	12
SBA-02	RE	145022	Biconical Antenna	Schwarzbeck	BBA9106	91032665	2019/4/1	2020/4/30	12
SCC-B1/B3/B5/B7/B8/B13/SRSE-02	RE	144975	Coaxial Cable&RF Selector	Fujikura/Fujikura/Suhner/Suhner/Suhner/Suhner/TOYO	8D2W/12DSF A/141PE/141 PE/141PE/141P	-/0901-270(RF Selector)	2019/4/19	2020/4/30	12
SCC-B2/B4/B6/B7/B8/B13/SRSE-02	RE	144976	Coaxial Cable&RF Selector	Fujikura/Fujikura/Suhner/Suhner/Suhner/Suhner/TOYO	8D2W/12DSF A/141PE/141 PE/141PE/141P	-/0901-270(RF Selector)	2019/4/19	2020/4/30	12

**UL Japan, Inc.**

**Shonan EMC Lab.**

1-22-3 Megumigaoka, Hiratsuka-shi, Kanagawa-ken, 259-1220 JAPAN

Telephone : +81 463 50 6400

Facsimile : +81 463 50 6401

**Test Instruments (2 / 2)**

Local ID	Test Name	LIMS ID	Description	Manufacturer	Model	Serial	Last Calibration Date	Calibration Due Date	Calibration Interval (Month)
SCC-G15	RE	145176	Coaxial Cable	Suhner	SUCOFLEX 102	32703/2	2019/3/27	2020/3/31	12
SCC-G40	RE	166491	Coaxial Cable	Junkosha	MWX221-01000NFSN MS/B	1612S005	2019/1/25	2020/1/31	12
SCC-G43	RE	156380	Coaxial Cable	HUBER+SUNER	SUCOFLEX_104 E	SN MY 13406/4E	2018/7/10	2019/7/31	12
SCC-G44	RE	168300	Coaxial Cable	HUBER+SUNER	SUCOFLEX 104	800070/4A	2019/3/26	2020/3/31	12
SFL-02	RE	145301	Highpass Filter	MICRO-TRONICS	HPM50111	51	2018/11/16	2019/11/30	12
SHA-03	RE	145501	Horn Antenna	Schwarzbeck	BBHA9120D	9120D-739	2018/7/23	2019/7/31	12
SHA-04	RE	145512	Horn Antenna	ETS LINDGREN	Sep-60	LM3640	2018/7/23	2019/7/31	12
SLA-06	RE	145528	Logperiodic Antenna	Schwarzbeck	VUSLP9111B	195	2019/4/1	2020/4/30	12
SOS-05	RE	146293	Humidity Indicator	A&D	AD-5681	4062518	2018/10/25	2019/10/31	12
STS-03	RE	146210	Digital Hitester	HIOKI	3805-50	80997823	2018/10/16	2019/10/31	12

**The expiration date of the calibration is the end of the expired month.**

**All equipment is calibrated with valid calibrations. Each measurement data is traceable to the national or international standards.**

**As for some calibrations performed after the tested dates, those test equipment have been controlled by means of an unbroken chains of calibrations.**

**Test item:** CE: Conducted Emission test  
RE: Radiated Emission test  
AT: Antenna Terminal Conducted test

**UL Japan, Inc.**

**Shonan EMC Lab.**

1-22-3 Megumigaoka, Hiratsuka-shi, Kanagawa-ken, 259-1220 JAPAN

Telephone : +81 463 50 6400

Facsimile : +81 463 50 6401