

# EMC TEST REPORT

<b>Applicant</b>	ID TECH
<b>FCC ID</b>	WQJ-VP8810PL
<b>Product</b>	VP8810P
<b>Brand</b>	ID TECH
<b>Model</b>	VP8810-8810; VP8810-8810D
<b>Report No.</b>	R2210A0938-E1
<b>Issue Date</b>	June 16, 2023

TA Technology (Shanghai) Co., Ltd. tested the above equipment in accordance with the requirements in **FCC Code CFR47 Part15B (2022)/ ANSI C63.4-2014**. The test results show that the equipment tested is capable of demonstrating compliance with the requirements as documented in this report.

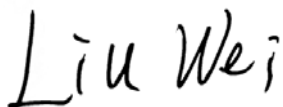

Prepared by: Liu Wei



Approved by: Fan Guangchang

## TA Technology (Shanghai) Co., Ltd.

Building 3, No.145, Jintang Rd, Pudong Shanghai, P.R.China

TEL: +86-021-50791141/2/3

FAX: +86-021-50791141/2/3-8000

## Table of Contents

1	Test Laboratory.....	4
1.1	Notes of the Test Report.....	4
1.2	Test Facility.....	4
1.3	Testing Location.....	4
2	General Description of Equipment Under Test.....	5
2.1	Applicant and Manufacturer Information.....	5
2.2	General Information.....	5
2.3	Applied Standards.....	7
2.4	Test Mode.....	8
3	Test Case Results.....	9
3.1	Radiated Emission.....	9
3.2	Conducted Emission.....	14
4	Uncertainty Measurement.....	17
5	Main Test Instruments.....	18
	ANNEX A: The EUT Appearance.....	19
	ANNEX B: Test Setup Photos.....	20
	ANNEX C: Product Change Description.....	21

## Summary of measurement results

Number	Test Case	Clause in FCC Rules	Conclusion
1	Radiated Emission	FCC Part15.109, ANSI C63.4-2014	PASS
2	Conducted Emission	FCC Part15.107, ANSI C63.4-2014	PASS
Date of Testing: November 2, 2022 ~ December 29, 2022			
Date of Sample Received: October 13, 2022			
Note: All indications of Pass/Fail in this report are opinions expressed by TA Technology (Shanghai) Co., Ltd. based on interpretations and/or observations of test results. Measurement Uncertainties were not taken into account and are published for informational purposes only.			

**VP8810-8810; VP8810-8810D (Report No.: R2210A0938-E1) is a variant model of VP6825-8100; VP6825-8100D (Report No.: R2210A0932-E1V1). This Product only changes Product Model and added printer keystroke. There is only tested Radiated Emission and Conducted Emission, and did not worsen, so they were not recorded in the report. The detailed product change description please refers to the *Difference Declaration Letter*.**

# 1 Test Laboratory

## 1.1 Notes of the Test Report

This report shall not be reproduced in full or partial, without the written approval of **TA Technology (Shanghai) Co., Ltd.** The results documented in this report apply only to the tested sample, under the conditions and modes of operation as described herein. Measurement Uncertainties were not taken into account and are published for informational purposes only. This report is written to support regulatory compliance of the applicable standards stated above.

## 1.2 Test Facility

### **FCC (Designation number: CN1179, Test Firm Registration Number: 446626)**

TA Technology (Shanghai) Co., Ltd. has been listed on the US Federal Communications Commission list of test facilities recognized to perform measurements.

### **A2LA (Certificate Number: 3857.01)**

TA Technology (Shanghai) Co., Ltd. has been listed by American Association for Laboratory Accreditation to perform measurement.

## 1.3 Testing Location

Company: TA Technology (Shanghai) Co., Ltd.  
Address: Building 3, No.145, Jintang Rd, Pudong Shanghai, P.R.China  
City: Shanghai  
Post code: 201201  
Country: P. R. China  
Contact: Fan Guangchang  
Telephone: +86-021-50791141/2/3  
Fax: +86-021-50791141/2/3-8000  
Website: <http://www.ta-shanghai.com>  
E-mail: [fanguangchang@ta-shanghai.com](mailto:fanguangchang@ta-shanghai.com)

## 2 General Description of Equipment Under Test

### 2.1 Applicant and Manufacturer Information

<b>Applicant</b>	ID TECH
<b>Applicant address</b>	10721 Walker Street, Cypress, California 90630, United States
<b>Manufacturer</b>	ID TECH TAIWAN
<b>Manufacturer address</b>	No. 16, Lane 22, GaoQing Rd., YanMei Dist., TaoYuan City 326, Taiwan

### 2.2 General Information

EUT Description			
Device Type	Movable Device		
Model	VP8810-8810; VP8810-8810D		
SN	(Original) 226K000755		
HW Version	Rev.A		
SW Version	v1.00		
Power Rating	DC 5V		
Connecting I/O Port(s)	Please refer to the User's Manual.		
Antenna Type	Internal Antenna		
Frequency	Band	Tx (MHz)	Rx (MHz)
	WCDMA Band II	1850 ~ 1910	1930 ~ 1990
	WCDMA Band IV	1710 ~ 1755	2110 ~ 2155
	WCDMA Band V	824 ~ 849	869 ~ 894
	LTE Band 2	1850 ~ 1910	1930 ~ 1990
	LTE Band 4	1710 ~ 1755	2110 ~ 2155
	LTE Band 5	824 ~ 849	869 ~ 894
	LTE Band 12	699 ~ 716	729 ~ 746
	LTE Band 13	777 ~ 787	746 ~ 756
	LTE Band 25	1850 ~ 1915	1930 ~ 1995
	LTE Band 26	814 ~ 849	859 ~ 894
	Bluetooth	2400 ~ 2483.5	2400 ~ 2483.5
	Wi-Fi 2.4G	2400 ~ 2483.5	2400 ~ 2483.5
	Wi-Fi 5G(U-NII-1)	5150 ~ 5250	5150 ~ 5250
	Wi-Fi 5G(U-NII-2A)	5250 ~ 5350	5250 ~ 5350
	Wi-Fi 5G(U-NII-2C)	5470 ~ 5725	5470 ~ 5725
Wi-Fi 5G(U-NII-3)	5725 ~ 5850	5725 ~ 5850	

	NFC	13.56	13.56
Note: 1. The EUT is sent from the applicant to TA and the information of the EUT is declared by the applicant. 2. VP8810-8810 and VP8810-8810D are the same except for different models.			

## 2.3 Applied Standards

According to the specifications of the manufacturer, it must comply with the requirements of the following standards:

### Test standards

**FCC Code CFR47 Part15B (2022)**

**ANSI C63.4-2014**

## 2.4 Test Mode

Test Mode	
Mode 1:	Adapter + EUT + auxiliary equipment + WCDMA/LTE/Bluetooth/WLAN/NFC Receiver
Mode 2:	Adapter + EUT + auxiliary equipment + Standby

During the test, the preliminary test was performed in all modes, mode 1 is selected as the worst condition. The test data of the worst-case condition was recorded in this report.



### 3 Test Case Results

#### 3.1 Radiated Emission

##### Ambient Condition

Temperature	Relative humidity
15°C~35°C	30%~60%

##### Methods of Measurement

The EUT is placed on a non-metallic table 0.8m above the horizontal metal reference ground plane. The distance between EUT and receive antenna should be 3 meters. During the test, the EUT was operating in its typical mode. The test method is according to ANSI C63.4-2014. Sweep the whole frequency band through the range from 30MHz to the 5th harmonic of the carrier. During the test, the height of receive antenna shall be moved from 1 to 4 meters, and the antenna shall be performed under horizontal and vertical polarization. The turn table shall be rotated from 0 to 360 degrees for detecting the maximum of radiated signal level.

The data of cable loss and antenna factor has been calibrated in full testing frequency range before the testing. During the test, the EUT is worked at maximum output power.

Set the spectrum analyzer in the following:

Below 1GHz:

RBW=100 kHz / VBW=300 kHz / Sweep=AUTO

Above 1GHz:

(a) PEAK Detector: RBW=1MHz / VBW=3MHz/ Sweep=AUTO

(b) AVERAGE Detector: RBW=1MHz / VBW=3MHz / Sweep=AUTO

The radiated emission was measured in the following position: EUT stand-up position (Z axis), lie-down position (X, Y axis). The worst emission was found in lie-down position (X axis) and the worst case was recorded.

During the test, EUT is connected to a laptop via a USB cable in the case of Transfer Data mode. The EUT is used as the peripheral equipment of the PC. The data is transferred from EUT to PC; PC is connected to server via a long LAN cable.

**Test Setup**

**Below 1GHz**

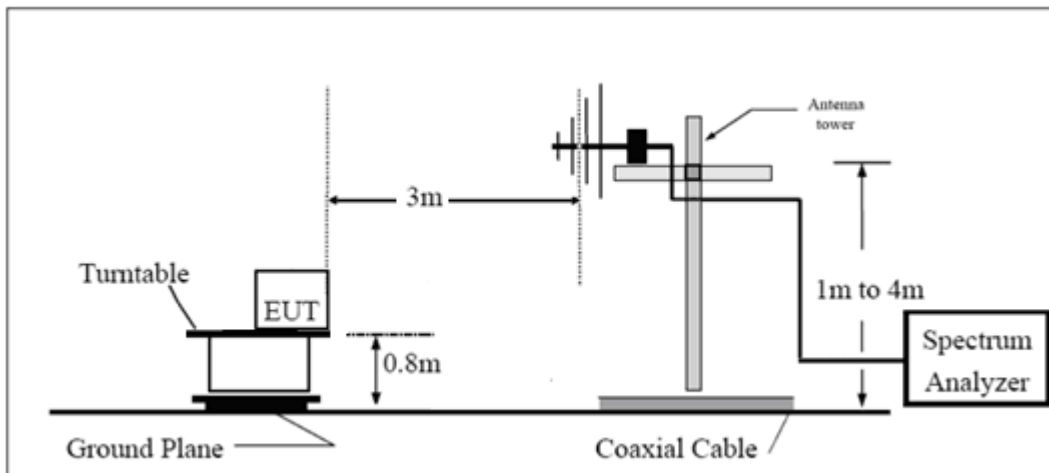

**Above 1GHz**

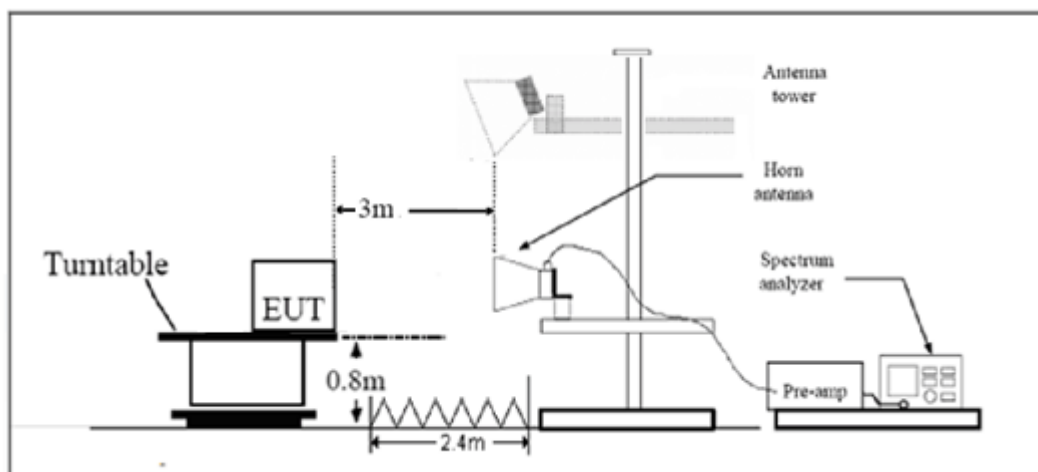

Note: Area side: 2.4mX3.6m

Antenna Tower meets ANSI C63.4 requirements for measurements above 1 GHz by keeping the antenna aimed at the EUT during the antenna's ascent/ descent along the antenna mast.

**Limits**
**Class B**

Frequency (MHz)	Field Strength (dB $\mu$ V/m)	Detector
30 -88	40.0	Quasi-peak
88-216	43.5	Quasi-peak
216 – 960	46.0	Quasi-peak
960-1000	54.0	Quasi-peak
1000-5 <sup>th</sup> harmonic of the highest frequency or 40GHz, which is lower	54 74	Average Peak

### Test Results

Sweep the whole frequency band through the range from 30MHz to the 5th harmonic of the carrier. The Emissions in the frequency band 18GHz – 40GHz is more than 20dB below the limit are not reported.

The following graphs display the maximum values of horizontal and vertical by software. For above 1GHz, Blue trace uses the peak detection, Green trace uses the average detection. A symbol (  $\text{dB } \mu\text{V/m}$  ) in the test plot below means (  $\text{dB}\mu\text{V/m}$  )

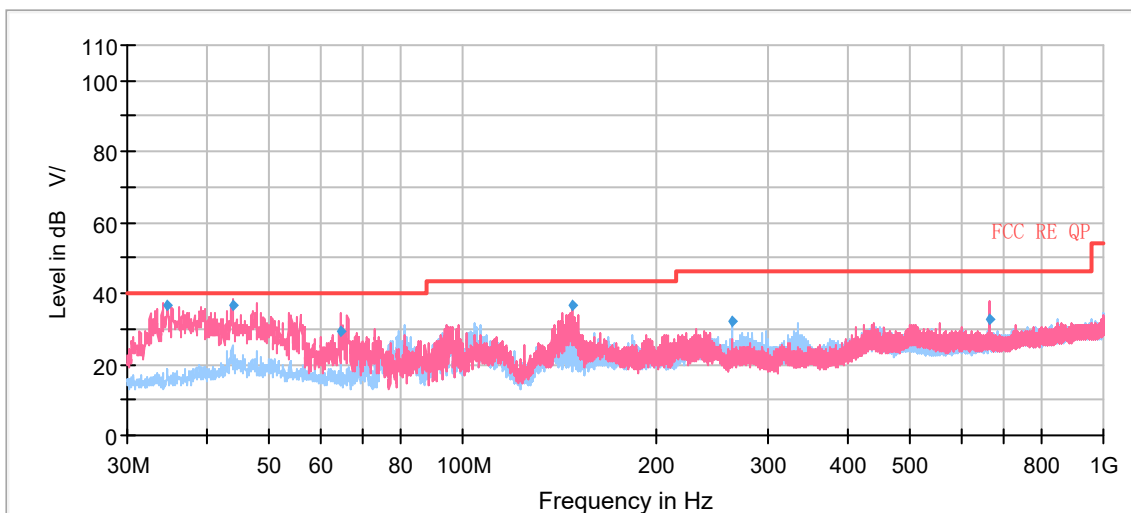

Radiated Emission from 30MHz to 1GHz

Frequency (MHz)	Quasi-Peak (dB $\mu\text{V/m}$ )	Limit (dB $\mu\text{V/m}$ )	Margin (dB)	Height (cm)	Polarization	Azimuth (deg)	Correct Factor (dB)
34.63	36.61	40.00	3.39	100.0	V	94.00	18
43.81	36.51	40.00	3.49	110.0	V	264.00	20
64.76	29.09	40.00	10.91	110.0	V	0.00	18
148.11	36.74	43.50	6.76	100.0	V	0.00	15
263.99	32.27	46.00	13.73	100.0	H	53.00	20
663.66	32.86	46.00	13.14	100.0	V	28.00	27

- Remark: 1. Correction Factor = Antenna factor + Insertion loss(cable loss+amplifier gain)**  
**2. Margin = Limit – Quasi-Peak**

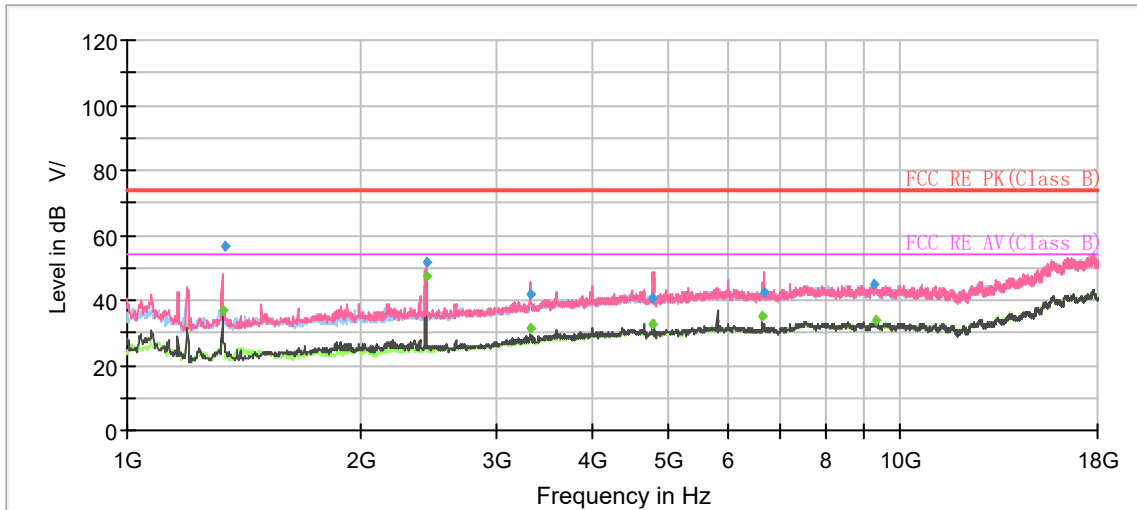

Radiated Emission from 1GHz to 18GHz

Frequency (MHz)	MaxPeak (dBµV/m)	Average (dBµV/m)	Limit (dB µ V/m)	Margin (dB)	Meas. Time (ms)	Height (cm)	Pol	Azimuth (deg)	Corr. (dB/m)
1331.16	---	36.95	54.00	17.05	500.00	200.0	V	164.00	-17
1334.60	56.41	---	74.00	17.59	500.00	200.0	V	164.00	-17
2434.58	---	47.23	54.00	6.77	500.00	100.0	V	213.00	-11
2435.40	51.93	---	74.00	22.07	500.00	100.0	V	213.00	-11
3328.06	---	31.20	54.00	22.80	500.00	200.0	V	306.00	-7
3330.22	41.85	---	74.00	32.15	500.00	200.0	V	246.00	-7
4787.04	40.74	---	74.00	33.26	500.00	100.0	V	143.00	-3
4788.36	---	32.80	54.00	21.20	500.00	100.0	V	143.00	-3
6645.59	---	35.06	54.00	18.94	500.00	100.0	V	133.00	-1
6656.88	42.21	---	74.00	31.79	500.00	100.0	V	154.00	-1
9227.23	44.76	---	74.00	29.24	500.00	100.0	H	248.00	2
9305.43	---	33.69	54.00	20.31	500.00	100.0	V	39.00	2

Remark: 1. Correction Factor = Antenna factor + Insertion loss (cable loss + amplifier gain)

2. Peak Margin = Limit -MAX Peak/ Average

## 3.2 Conducted Emission

### Ambient Condition

Temperature	Relative humidity
15°C~35°C	30%~60%

### Methods of Measurement

The EUT is placed on a non-metallic table of 80cm height above the horizontal metal reference ground plane. During the test, the EUT was operating in its typical mode. The test method is according to ANSI C63.4-2014. Connect the AC power line of the EUT to the L.I.S.N. Use EMI receiver to detect the average and Quasi-peak value. RBW is set to 9 kHz, VBW is set to 30kHz. The measurement result should include both L line and N line.

During the test, EUT is connected to a laptop via a USB cable in the case of Transfer Data mode. The EUT is used as the peripheral equipment of the PC. The data is transferred from EUT to PC; PC is connected to server via a long LAN cable.

### Test Setup

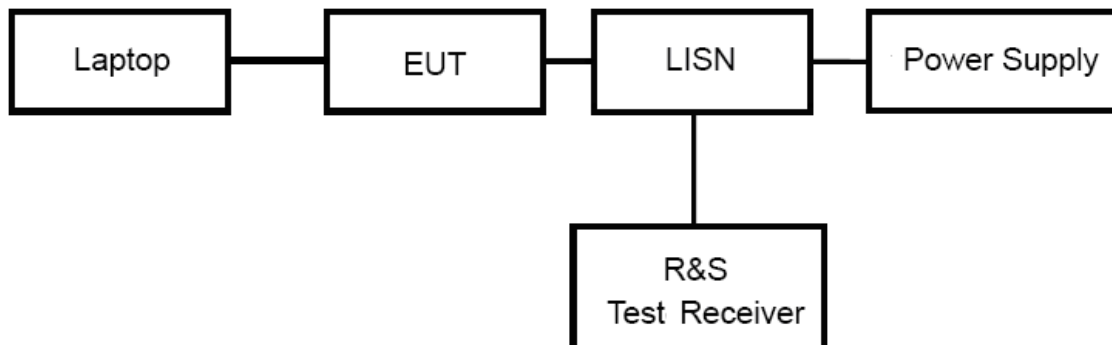

Note: Power Supply is AC Power source and it is used to change the voltage 120V/60Hz.

### Limits

Frequency (MHz)	Conducted Limits(dB $\mu$ V)	
	Quasi-peak	Average
0.15 - 0.5	66 to 56 *	56 to 46 *
0.5 - 5	56	46
5 - 30	60	50

\*: Decreases with the logarithm of the frequency.

**Test Results**

Following plots, Blue trace uses the peak detection; Green trace uses the average detection.

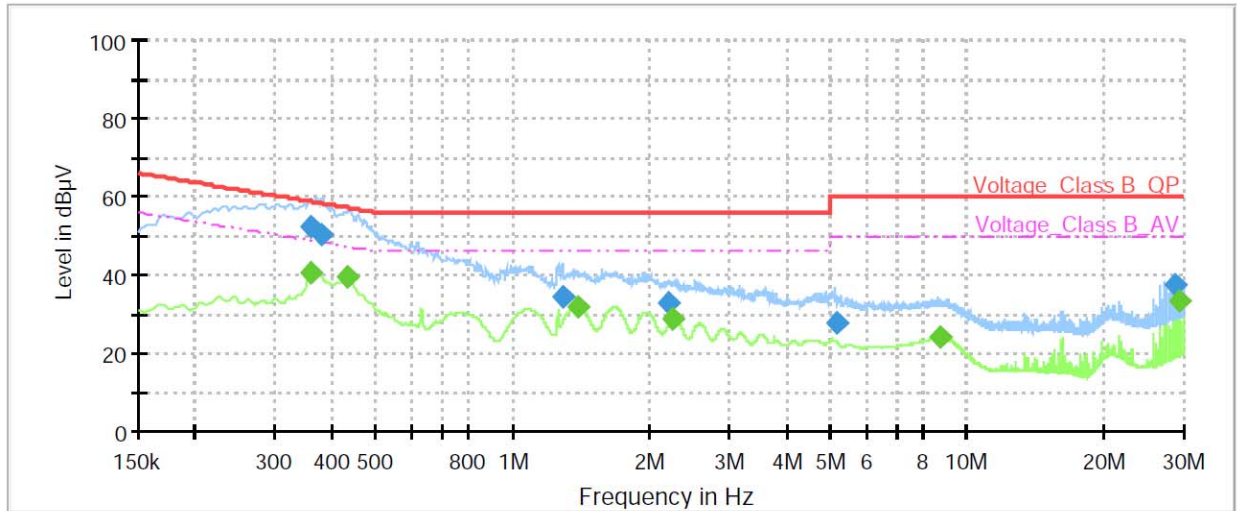

Frequency (MHz)	QuasiPeak (dBµV)	Average (dBµV)	Limit (dBµV)	Margin (dB)	Meas. Time (ms)	Bandwidth (kHz)	Line	Filter	Corr. (dB)
0.359250	---	40.64	48.75	8.11	1000.0	9.000	L1	ON	20.5
0.359250	52.10	---	58.75	6.65	1000.0	9.000	L1	ON	20.5
0.379500	50.36	---	58.29	7.93	1000.0	9.000	L1	ON	20.5
0.433500	---	39.43	47.19	7.76	1000.0	9.000	L1	ON	20.4
1.286250	34.38	---	56.00	21.62	1000.0	9.000	L1	ON	19.7
1.387500	---	31.90	46.00	14.10	1000.0	9.000	L1	ON	19.7
2.211000	32.85	---	56.00	23.15	1000.0	9.000	L1	ON	19.5
2.260500	---	28.82	46.00	17.18	1000.0	9.000	L1	ON	19.5
5.149500	27.58	---	60.00	32.42	1000.0	9.000	L1	ON	19.5
8.715750	---	23.96	50.00	26.04	1000.0	9.000	L1	ON	19.6
28.684500	37.64	---	60.00	22.36	1000.0	9.000	L1	ON	20.0
29.235750	---	33.50	50.00	16.50	1000.0	9.000	L1	ON	20.0

Remark: Correct factor=cable loss + LISN factor

L line

Conducted Emission from 150 KHz to 30 MHz

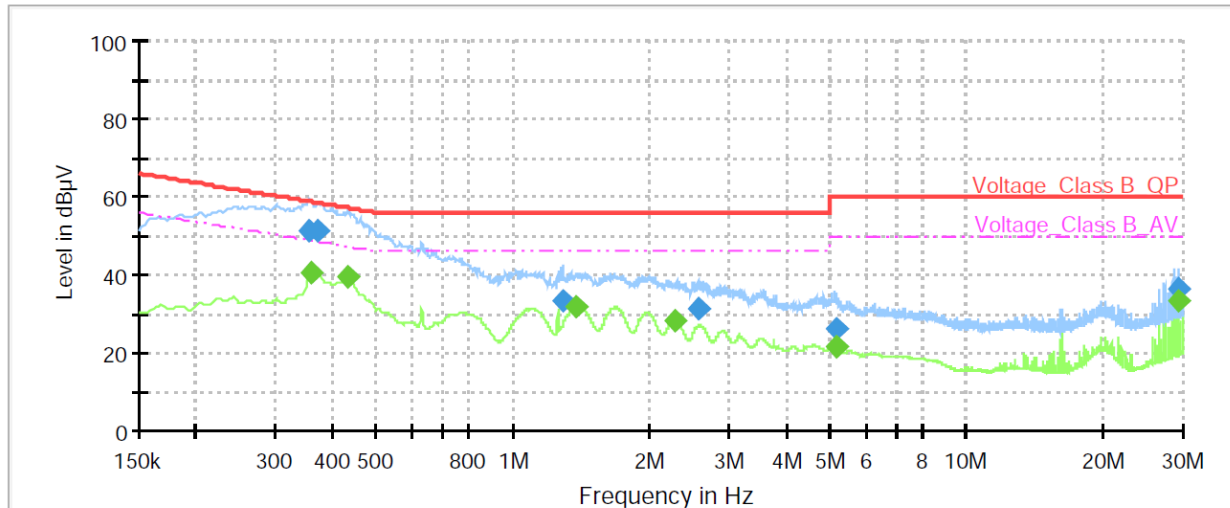

Frequency (MHz)	QuasiPeak (dBµV)	Average (dBµV)	Limit (dBµV)	Margin (dB)	Meas. Time (ms)	Bandwidth (kHz)	Line	Filter	Corr. (dB)
0.357000	51.39	---	58.80	7.41	1000.0	9.000	N	ON	20.5
0.359250	---	40.51	48.75	8.24	1000.0	9.000	N	ON	20.5
0.372750	51.50	---	58.44	6.94	1000.0	9.000	N	ON	20.5
0.433500	---	39.48	47.19	7.71	1000.0	9.000	N	ON	20.5
1.286250	33.25	---	56.00	22.75	1000.0	9.000	N	ON	19.7
1.385250	---	31.80	46.00	14.20	1000.0	9.000	N	ON	19.7
2.267250	---	28.41	46.00	17.59	1000.0	9.000	N	ON	19.5
2.573250	31.36	---	56.00	24.64	1000.0	9.000	N	ON	19.5
5.145000	26.38	---	60.00	33.62	1000.0	9.000	N	ON	19.5
5.147250	---	21.76	50.00	28.24	1000.0	9.000	N	ON	19.5
29.233500	36.57	---	60.00	23.43	1000.0	9.000	N	ON	19.9
29.235750	---	33.09	50.00	16.91	1000.0	9.000	N	ON	19.9

Remark: Correct factor=cable loss + LISN factor

N line

Conducted Emission from 150 KHz to 30 MHz



## 4 Uncertainty Measurement

Case	Uncertainty	Factor k
Radiated Emission 30MHz – 200MHz	4.17 dB	1.96
Radiated Emission 200MHz – 1GHz	4.84 dB	1.96
Radiated Emission 1GHz – 18GHz	4.35 dB	1.96
Conducted Emission	2.57 dB	2

## 5 Main Test Instruments

Name of Equipment	Manufacturer	Type/Model	Serial Number	Calibration Date	Expiration Time
Radiated Emission					
EMI Test Receiver	R&S	ESR	102389	2022-05-25	2023-05-24
Signal Analyzer	R&S	FSV40	101186	2022-05-14	2023-05-13
TRILOG Broadband Antenna	SCHWARZBECK	VULB 9163	1023	2020-05-05	2023-05-04
Horn Antenna	R&S	HF907	102723	2020-08-11	2023-08-10
Horn Antenna	ETS-Lindgren	3160-09	00102643	2021-10-10	2024-10-09
Horn Antenna	STEATITE	QSH-SL-26-40-K-15	16779	2019-12-24	2024-12-23
Software	R&S	EMC32	9.26.01	/	/
Conducted Emission					
Artificial main network	R&S	ENV216	102191	2020-12-13	2022-12-12
				2022-12-10	2024-12-09
EMI Test Receiver	R&S	ESR	101667	2022-05-25	2023-05-24
Software	R&S	EMC32	10.35.10	/	/

\*\*\*\*\*END OF REPORT \*\*\*\*\*

## ANNEX A: The EUT Appearance

The EUT Appearance are submitted separately.

## ANNEX B: Test Setup Photos

The Test Setup Photos are submitted separately.

## **ANNEX C: Product Change Description**

**The Product Change Description are submitted separately.**