

FCC 47 CFR PART 15 SUBPART C

TEST REPORT

For

VP8300

Model No.:

IDV8-300P, IDV8-300, IDV8-300N, IDV8-300A, IDV8-300AP

Trade Name: ID TECH

Issued to

**ID TECH
10721 Walker St. Cypress, CA 90630**

Issued by

**Compliance Certification Services Inc.
Wugu Laboratory
No.11, Wugong 6th Rd., Wugu Dist.,
New Taipei City 24891, Taiwan. (R.O.C.)
<http://www.ccsrf.com>
service@ccsrf.com
Issued Date: December 15, 2017**



Testing Laboratory
1309

Note: This report shall not be reproduced except in full, without the written approval of Compliance Certification Services Inc. This document may be altered or revised by Compliance Certification Services Inc. personnel only, and shall be noted in the revision section of the document.

Revision History

Rev.	Issue Date	Revisions	Effect Page	Revised By
00	December 15, 2017	Initial Issue	ALL	Allison Chen
01	January 23, 2018	1. Remove Polarity and added notes. 2. Modify section 6.2.	P.17, P.11	Angel Cheng
02	January 24, 2018	1. Added remark 2.	P.16	Angel Cheng

TABLE OF CONTENTS

1. TEST RESULT CERTIFICATION.....	4
2. EUT DESCRIPTION.....	5
3. TEST METHODOLOGY.....	6
3.1 EUT CONFIGURATION.....	6
3.2 FCC PART 15.205 RESTRICTED BANDS OF OPERATIONS.....	6
3.3 DESCRIPTION OF TEST MODES.....	7
4. INSTRUMENT CALIBRATION.....	8
4.1 MEASURING INSTRUMENT CALIBRATION.....	8
4.2 MEASUREMENT EQUIPMENT USED.....	8
4.3 MEASUREMENT UNCERTAINTY.....	9
5. FACILITIES AND ACCREDITATIONS.....	10
5.1 FACILITIES.....	10
5.2 EQUIPMENT.....	10
6. SETUP OF EQUIPMENT UNDER TEST.....	11
6.1 SETUP CONFIGURATION OF EUT.....	11
6.2 SUPPORT EQUIPMENT.....	11
7. FCC PART 15.225 REQUIREMENTS REQUIREMENTS.....	12
7.1 OCCUPIED BANDWIDTH(99%) AND 20 DB BANDWIDTH.....	12
7.2 RADIATED EMISSIONS.....	14
7.3 FREQUENCY STABILITY.....	22
7.4 POWERLINE CONDUCTED EMISSIONS.....	24
APPENDIX I PHOTOGRAPHS OF TEST SETUP.....	27
APPENDIX 1 - PHOTOGRAPHS OF EUT	

1. TEST RESULT CERTIFICATION

Applicant: ID TECH
 10721 Walker St. Cypress, CA 90630

Manufacturer: ID TECH Taiwan Co., Ltd
 No.16, Lane 22, GaoQing Rd., YangMei Dist., TaoYuan City
 32667, Taiwan

Equipment Under Test: VP8300

Trade Name: ID TECH

Model No.: IDV8-300P, IDV8-300, IDV8-300N, IDV8-300A, IDV8-300AP

Date of Test: November 24 ~ December 11, 2017

APPLICABLE STANDARDS	
STANDARD	TEST RESULT
FCC 47 CFR Part 15 Subpart C	No non-compliance noted

We hereby certify that:

The above equipment was tested by Compliance Certification Services Inc. The test data, data evaluation, test procedures, and equipment configurations shown in this report were made in accordance with the procedures given in ANSI C63.10: 2013 and the energy emitted by the sample tested as described in this report is in compliance with the requirements of FCC Rules Part 15.225.

The test results of this report relate only to the tested sample identified in this report.

Approved by:

Tested by:

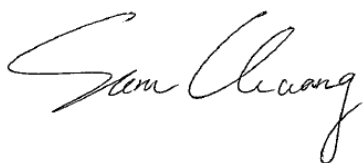

Sam Chuang
 Manager
 Compliance Certification Services Inc.

Jerry Chuang
 Engineer
 Compliance Certification Services Inc.

2. EUT DESCRIPTION

Product	VP8300													
Model No.	IDV8-300P, IDV8-300, IDV8-300N, IDV8-300A, IDV8-300AP													
Model Discrepancy	<table border="1"> <thead> <tr> <th>Model No.</th> <th>Different description</th> </tr> </thead> <tbody> <tr> <td>IDV8-300</td> <td>TDES;MSR/MSD encrypt ON; EMV encrypt OFF</td> </tr> <tr> <td>IDV8-300P</td> <td>TDES;MSR/MSD/EMV encrypt ON</td> </tr> <tr> <td>IDV8-300N</td> <td>MSR/MSD/EMV encrypt OFF</td> </tr> <tr> <td>IDV8-300A</td> <td>AES;MSR/MSD encrypt ON; EMV encrypt OFF</td> </tr> <tr> <td>IDV8-300AP</td> <td>AES;MSR/MSD/EMV encrypt ON</td> </tr> </tbody> </table>		Model No.	Different description	IDV8-300	TDES;MSR/MSD encrypt ON; EMV encrypt OFF	IDV8-300P	TDES;MSR/MSD/EMV encrypt ON	IDV8-300N	MSR/MSD/EMV encrypt OFF	IDV8-300A	AES;MSR/MSD encrypt ON; EMV encrypt OFF	IDV8-300AP	AES;MSR/MSD/EMV encrypt ON
	Model No.	Different description												
	IDV8-300	TDES;MSR/MSD encrypt ON; EMV encrypt OFF												
	IDV8-300P	TDES;MSR/MSD/EMV encrypt ON												
	IDV8-300N	MSR/MSD/EMV encrypt OFF												
	IDV8-300A	AES;MSR/MSD encrypt ON; EMV encrypt OFF												
	IDV8-300AP	AES;MSR/MSD/EMV encrypt ON												
Note: TDES= cryptography, Triple DES														
Trade	ID TECH													
Received Date	November 17, 2017													
Power Supply	Powered form host device via USB Cable. (DC 5V)													
Frequency Range	13.56MHz													
Modulation Technique	ASK													
Number of Channels	1 Channel													

Remark:

1. *The sample selected for test was engineering sample that approximated to production product and was provided by manufacturer.*

3. TEST METHODOLOGY

The tests documented in this report were performed in accordance with ANSI C63.10: 2013 and FCC CFR 47 Part 15.207, 15.209, 15.225.

3.1 EUT CONFIGURATION

The EUT configuration for testing is installed on RF field strength measurement to meet the Commissions requirement and operating in a manner that intends to maximize its emission characteristics in a continuous normal application.

3.2 FCC PART 15.205 RESTRICTED BANDS OF OPERATIONS

(a) Except as shown in paragraph (d) of this section, only spurious emissions are permitted in any of the frequency bands listed below:

MHz	MHz	MHz	GHz
0.090 - 0.110	16.42 - 16.423	399.9 - 410	4.5 - 5.15
¹ 0.495 - 0.505	16.69475 - 16.69525	608 - 614	5.35 - 5.46
2.1735 - 2.1905	16.80425 - 16.80475	960 - 1240	7.25 - 7.75
4.125 - 4.128	25.5 - 25.67	1300 - 1427	8.025 - 8.5
4.17725 - 4.17775	37.5 - 38.25	1435 - 1626.5	9.0 - 9.2
4.20725 - 4.20775	73 - 74.6	1645.5 - 1646.5	9.3 - 9.5
6.215 - 6.218	74.8 - 75.2	1660 - 1710	10.6 - 12.7
6.26775 - 6.26825	108 - 121.94	1718.8 - 1722.2	13.25 - 13.4
6.31175 - 6.31225	123 - 138	2200 - 2300	14.47 - 14.5
8.291 - 8.294	149.9 - 150.05	2310 - 2390	15.35 - 16.2
8.362 - 8.366	156.52475 -	2483.5 - 2500	17.7 - 21.4
8.37625 - 8.38675	156.52525	2655 - 2900	22.01 - 23.12
8.41425 - 8.41475	156.7 - 156.9	3260 - 3267	23.6 - 24.0
12.29 - 12.293	162.0125 - 167.17	3332 - 3339	31.2 - 31.8
12.51975 - 12.52025	167.72 - 173.2	3345.8 - 3358	36.43 - 36.5
12.57675 - 12.57725	240 - 285	3600 - 4400	(²)
13.36 - 13.41	322 - 335.4		

¹ Until February 1, 1999, this restricted band shall be 0.490-0.510 MHz.

² Above 38.6

(b) Except as provided in paragraphs (d) and (e), the field strength of emissions appearing within these frequency bands shall not exceed the limits shown in Section 15.209. At frequencies equal to or less than 1000 MHz, compliance with the limits in Section 15.209 shall be demonstrated using measurement instrumentation employing a CISPR quasi-peak detector. Above 1000 MHz, compliance with the emission limits in Section 15.209 shall be demonstrated based on the average value of the measured emissions. The provisions in Section 15.35 apply to these measurements.

3.3 DESCRIPTION OF TEST MODES

The EUT had been tested under engineering test mode condition and the EUT staying in continuous transmitting mode.

All modes and data rates were investigated and it was determined that ISO 14443A/B and ISO 18092 Type y, 106/212/424/848 kbps.

All data rates were investigated and it was determined that 106 Kbps was considered worst-case. Therefore, all testing was performed in 106 Kbps mode.

3.3.1 The worst mode of measurement

Radiated Emission Measurement Below 1G	
Test Condition	Radiated Emission Below 1G
Voltage/Hz	5V
Test Mode	Mode 1:EUT power by Host System.
Worst Mode	<input checked="" type="checkbox"/> Mode 1 <input type="checkbox"/> Mode 2 <input type="checkbox"/> Mode 3 <input type="checkbox"/> Mode 4

Remark:

1. *The worst mode was record in this test report.*
2. *EUT pre-scanned in three axis ,X, Y, Z and two polarity, Horizontal and Vertical for radiated measurement. The worst case(Z-Plane and Horizontal) were recorded in this report*
3. *For below 1G, AC power line conducted emission and radiation emission were performed the EUT transmit at the highest output power channel as worse case.*

4. INSTRUMENT CALIBRATION

4.1 MEASURING INSTRUMENT CALIBRATION

The measuring equipment, which was utilized in performing the tests documented herein, has been calibrated in accordance with the manufacturer's recommendations for utilizing calibration equipment, which is traceable to recognized national standards.

4.2 MEASUREMENT EQUIPMENT USED

Equipment Used for Emissions Measurement

Remark: Each piece of equipment is scheduled for calibration once a year

Conducted Emissions Test Site					
Name of Equipment	Manufacturer	Model	S/N	Calibration Date	Calibration Due
Spectrum Analyzer	R&S	FSV 40	101073	10/02/2017	10/01/2018
Thermostatic/Hrgrosatic Chamber	GWINSTEK	GTC-288MH-CC	TH160402	05/23/2017	05/22/2018
Directional Coupler	Agilent	87301D	MY44350252	07/25/2017	07/24/2018
SUCOFLEX Cable	HUBER SUHNER	SUCOFLEX 104PEA	25157	07/31/2017	07/30/2018
Divider	Solvang Technology	2-18GHz 4Way	STI08-0015	07/26/2017	07/25/2018

Wugu 966 Chamber A					
Name of Equipment	Manufacturer	Model	S/N	Calibration Date	Calibration Due
Bilog Antenna	Sunol Sciences	JB3	A030105	06/20/2017	06/19/2018
Pre-Amplifier	EMEC	EM330	060609	06/07/2017	06/06/2018
Spectrum Analyzer	Agilent	E4446A	US42510252	11/27/2017	11/26/2018
Loop Ant	COM-POWER	AL-130	121051	03/02/2017	03/01/2018
Antenna Tower	CCS	CC-A-1F	N/A	N.C.R	N.C.R
Controller	CCS	CC-C-1F	N/A	N.C.R	N.C.R
Turn Table	CCS	CC-T-1F	N/A	N.C.R	N.C.R

AC Conducted Emissions Test Site					
Equipment	Manufacturer	Model	S/N	Cal Date	Cal Due
DC LISN	SCHWARZBECK	NNBM 8124	505	03/20/2017	03/19/2018
DC LISN	SCHWARZBECK	NNBM 8124	504	03/20/2017	03/19/2018
EMI Test Receiver	R&S	ESCI	W3010659	07/13/2017	07/12/2018

Remark:

1. Each piece of equipment is scheduled for calibration once a year and Precision Dipole is scheduled for calibration once three years.
2. N.C.R. = No Calibration Request.

4.3 MEASUREMENT UNCERTAINTY

PARAMETER	UNCERTAINTY
Powerline Conducted Emission	+/- 1.2159
3M Semi Anechoic Chamber / 30M~200M	+/- 4.0138
3M Semi Anechoic Chamber / 200M~1000M	+/- 3.9483
3M Semi Anechoic Chamber / 1G~8G	+/- 2.5975
3M Semi Anechoic Chamber / 8G~18G	+/- 2.6112
3M Semi Anechoic Chamber / 18G~26G	+/- 2.7389
3M Semi Anechoic Chamber / 26G~40G	+/- 2.9683

Remark: This uncertainty represents an expanded uncertainty expressed at approximately the 95% confidence level using a coverage factor of $k=2$.

5. FACILITIES AND ACCREDITATIONS

5.1 FACILITIES

All measurement facilities used to collect the measurement data are located at

- No.199, Chunghsen Road, Hsintien City, Taipei Hsien, Taiwan, R.O.C.
Tel: 886-2-2217-0894 / Fax: 886-2-2217-1029
- No.11, Wugong 6th Rd., Wugu Dist., New Taipei City 24891, Taiwan. (R.O.C.)
Tel: 886-2-2299-9720 / Fax: 886-2-2298-4045

The sites are constructed in conformance with the requirements of ANSI C63.7, ANSI C63.10: 2013 and CISPR Publication 22.

5.2 EQUIPMENT

Radiated emissions are measured with one or more of the following types of linearly polarized antennas: tuned dipole, bucolical, log periodic, bi-log, and/or ridged waveguide, horn. Spectrum analyzers with pre-selectors and quasi-peak detectors are used to perform radiated measurements.

Conducted emissions are measured with Line Impedance Stabilization Networks and EMI Test Receivers.

Calibrated wideband preamplifiers, coaxial cables, and coaxial attenuators are also used for making measurements.

All receiving equipment conforms to CISPR Publication 16-1, "Radio Interference Measuring Apparatus and Measurement Methods."

6. SETUP OF EQUIPMENT UNDER TEST

6.1 SETUP CONFIGURATION OF EUT

See test photographs attached in Appendix I for the actual connections between EUT and support equipment.

6.2 SUPPORT EQUIPMENT

No.	Device Type	Brand	Model	Series No.	FCC ID	Data Cable	Power Cord
1.	NB(H)	Acer	Aspire 4320 series	R33142	QDS-BRCM10 18	N/A	N/A
2.	DC Power Source	Agilent	E3640A	N/A	N/A	DC Cable 1.5m shielding	N/A

Remark:

- 1. All the equipment/cables were placed in the worst-case configuration to maximize the emission during the test.*
- 2. Grounding was established in accordance with the manufacturer's requirements and conditions for the intended use.*

7. FCC PART 15.225 REQUIREMENTS REQUIREMENTS

7.1 OCCUPIED BANDWIDTH(99%) AND 20 DB BANDWIDTH

TEST CONFIGURATION

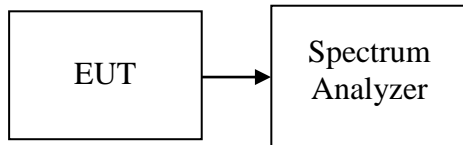

TEST PROCEDURE

1. Place the EUT on the table and set it in the transmitting mode.
2. Remove the antenna from the EUT and then connect a low loss RF cable from the antenna port to the spectrum analyzer.
3. Set the spectrum analyzer as RBW=1kHz, VBW = 3kHz, Span = 10kHz, Sweep = auto.
4. Record the max. reading.

TEST RESULTS

No non-compliance noted

Test Condition	Frequency(MHz)	Occupied Bandwidth 99% (kHz)	20 dB Bandwidth (kHz)
NFC	13.56	2.0984	2.4750

Test Plot

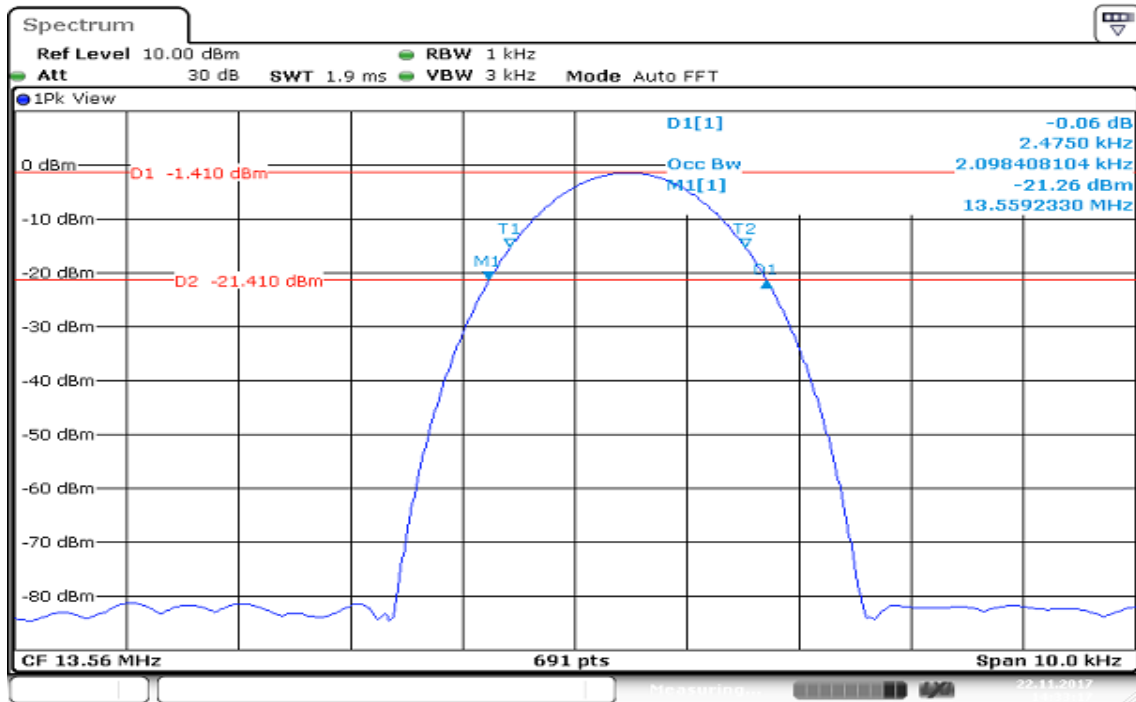

Date: 22.NOV.2017 14:33:17

7.2 RADIATED EMISSIONS

LIMIT

According to §15.225

- (a) The field strength of any emissions within the band 13.553 – 13.567 MHz shall not exceed 15,848 microvolts / meter at 30 meters.
- (b) Within the bands 13.410 – 13.553 MHz and 13.567 -13.710 MHz, the field strength of any emissions shall not exceed 334 microvolts / meter at 30 meters.
- (c) Within the bands 13.110 – 13.410 MHz and 13.710 – 14.010 MHz the field strength of any emissions shall not exceed 106 microvolts / meter at 30 meters.
- (d) The field strength of any emissions appearing outside of the 13.110 – 14.010 MHz and shall not exceed the general radiated emission limits in §15.209.

According to §15.225, except as provided elsewhere in this Subpart, the emissions from an intentional radiator shall not exceed the field strength levels specified in the following table:

Frequency (MHz)	Field Strength ($\mu\text{V}/\text{m}$ at meter)	Measurement Distance (meter)
0.009 – 0.490	2400 / F (kHz)	300
0.490 – 1.705	24000 / F (kHz)	30
1.705 – 30.0	30	30
30 - 88	100**	3
88-216	150**	3
216-960	200**	3
Above 960	500	3

** Except as provided in paragraph (g), fundamental emissions from intentional radiators operating under this Section shall not be located in the frequency bands 54-72 MHz, 76-88 MHz, 174-216 MHz or 470-806 MHz. However, operation within these frequency bands is permitted under other sections of this Part, e.g., Sections 15.231 and 15.241.

Test Configuration

9kHz ~ 30MHz

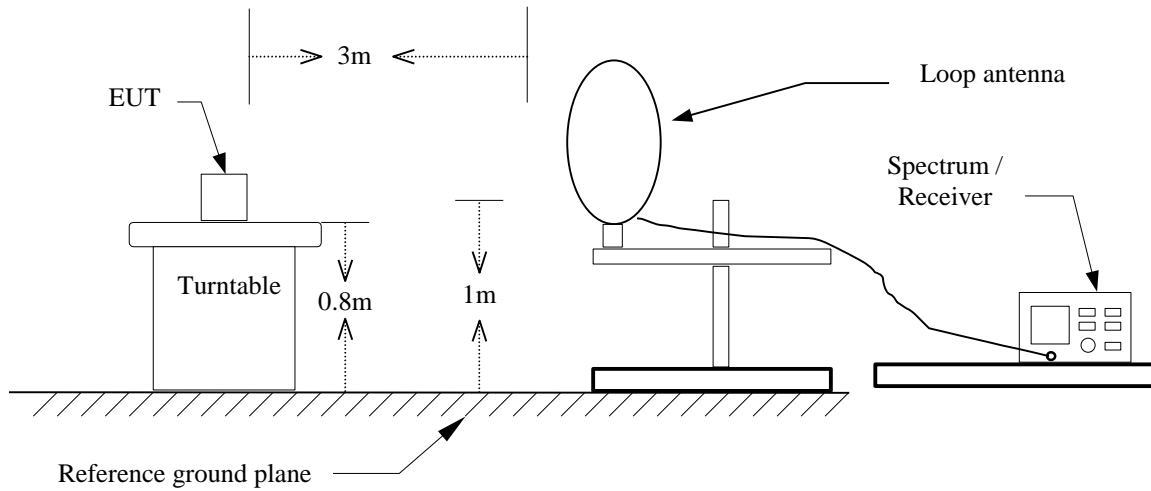

30MHz ~ 1GHz

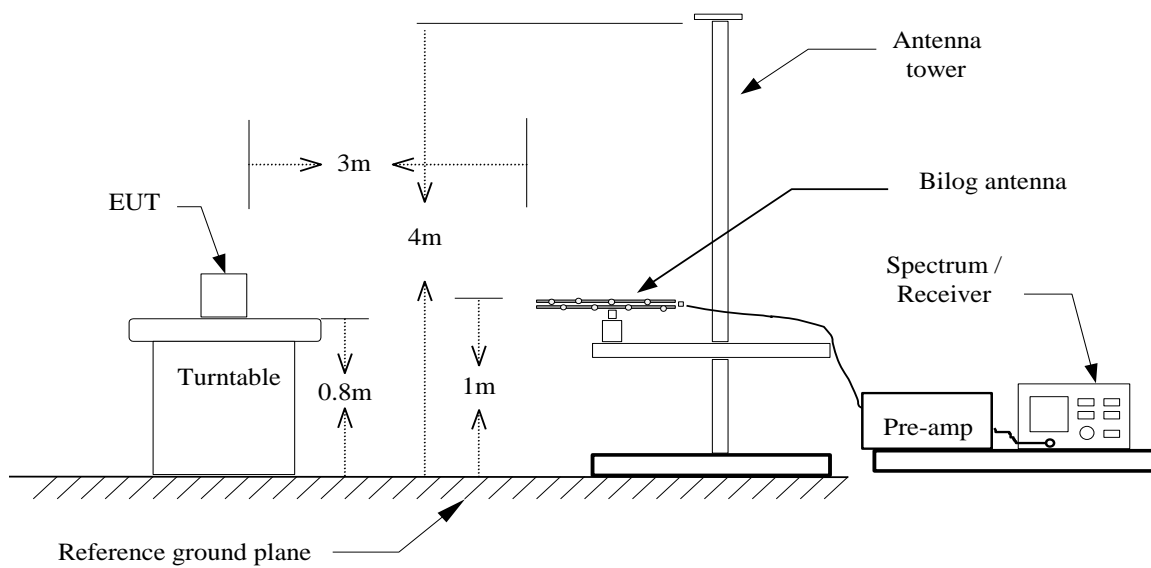

TEST PROCEDURE

For 9kHz ~ 30MHz

1. The EUT is placed on a turntable, which is 0.8m above ground plane.
2. The turntable shall be rotated for 360 degrees to determine the position of maximum emission level.
3. EUT is set 3m away from the receiving antenna, The center of the loop shall be 1 m above the ground then to find out the highest emissions.
4. Maximum procedure was performed on the six highest emissions to ensure EUT compliance.
5. Set the spectrum analyzer in the following setting as:
9KHz-490KHz : RBW=200Hz / VBW=1kHz / Sweep=AUTO
490KHz-30MHz : RBW=10kHz / VBW=30kHz / Sweep=AUTO
6. Repeat above procedures until the measurements for all frequencies are complete.

For 30MHz ~ 1GHz

1. The EUT is placed on a turntable, which is 0.8m above ground plane.
2. The turntable shall be rotated for 360 degrees to determine the position of maximum emission level.
3. EUT is set 3m away from the receiving antenna, which is varied from 1m to find out the highest emissions.
4. Maximum procedure was performed on the six highest emissions to ensure EUT compliance.
5. And also, each emission was to be maximized by changing the polarization of receiving antenna both horizontal and vertical.
6. Set the spectrum analyzer in the following setting as:
RBW=100kHz / VBW=300kHz / Sweep=AUTO
7. Repeat above procedures until the measurements for all frequencies are complete.

Remark :

1. *Although these tests were performed other than open area test site, adequate comparison measurements were confirmed against 30 m open area test site. Therefore sufficient tests were made to demonstrate that the alternative site produces results that correlate with the ones of tests made in an open field based on KDB 937606.*
2. *EUT pre-scanned in vertical and horizontal polarity from loop antenna for radiated measurement. The worst case was horizontal polarity.*

Operation Mode: TX mode **Test Date:** December 11, 2017
Temperature: 24°C **Tested by:** Jerry Chuang
Humidity: 33 % RH



No.	Frequency (MHz)	Reading (dBuV)	Correct Factor(dB/m)	Result (dBuV/m)	Limit (dBuV/m)	Margin (dB)	Remark
1	13.5609	48.93	15.21	64.14	124.00	-59.86	peak

Remark:

1. Radiated emissions measured were made with an instrument using peak/quasi-peak/average detector mode.
2. Measurements above show only up to 6 maximum emissions noted, or would be lesser, with " N/A " remark, if no specific emissions from the EUT are recorded (ie: margin>20dB from the applicable limit) and considered that's already beyond the background noise floor.
3. Margin (dB) = Result (dBuV/m) – Limit (dBuV/m).
4. Correct factor = Loop antenna factor + Cable loss:
5. 124 dBuV/m = 20 log(15848)+40 log(30/3)

9kHz ~ 490kHz

Operation Mode: TX mode
Temperature: 24°C
Humidity: 33 % RH

Test Date: December 11, 2017
Tested by: Jerry Chuang

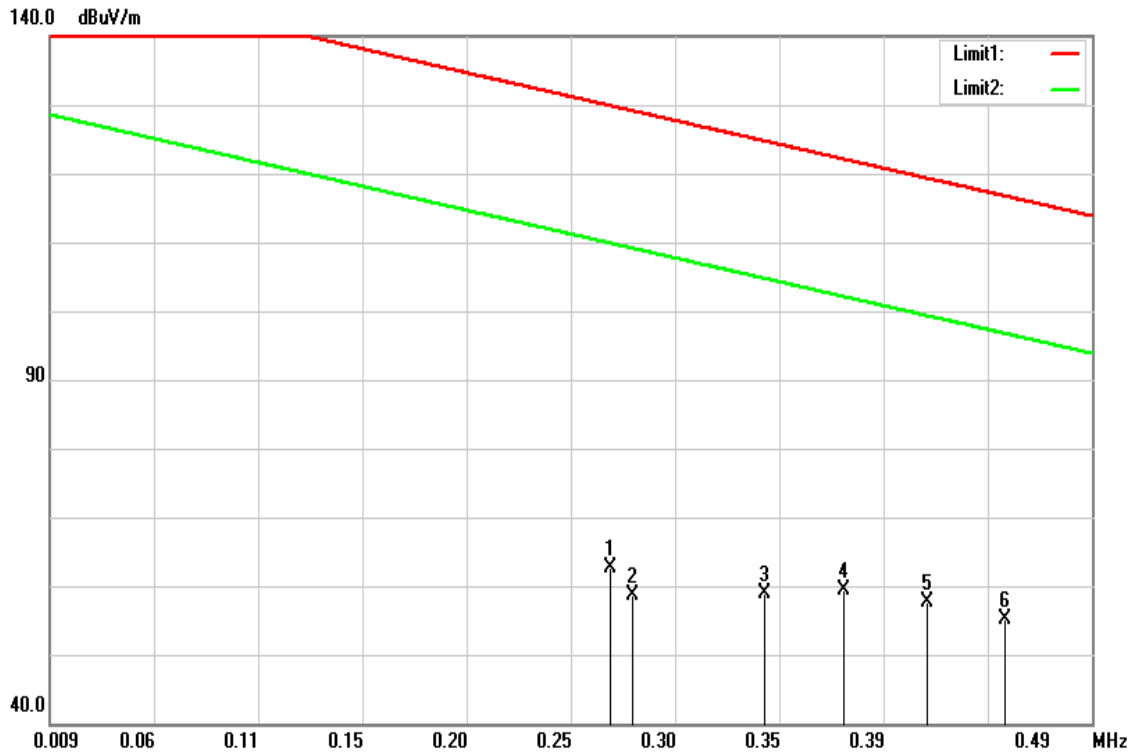

Frequency (MHz)	Reading (dBuV)	Correction Factor (dB/m)	Result (dBuV/m)	Limit (dBuV/m)	Margin (dB)	Detector Mode (PK/QP/AVG)
0.2678	48.44	14.24	62.68	129.84	-67.16	peak
0.2779	44.44	14.23	58.67	129.11	-70.44	peak
0.3390	44.59	14.26	58.85	124.70	-65.85	peak
0.3755	45.02	14.29	59.31	122.06	-62.75	peak
0.4140	43.29	14.33	57.62	119.29	-61.67	peak
0.4501	40.73	14.36	55.09	116.68	-61.59	peak

490kHz ~ 30MHz

Operation Mode: TX mode
Temperature: 24°C
Humidity: 33 % RH

Test Date: December 11, 2017
Tested by: Jerry Chuang

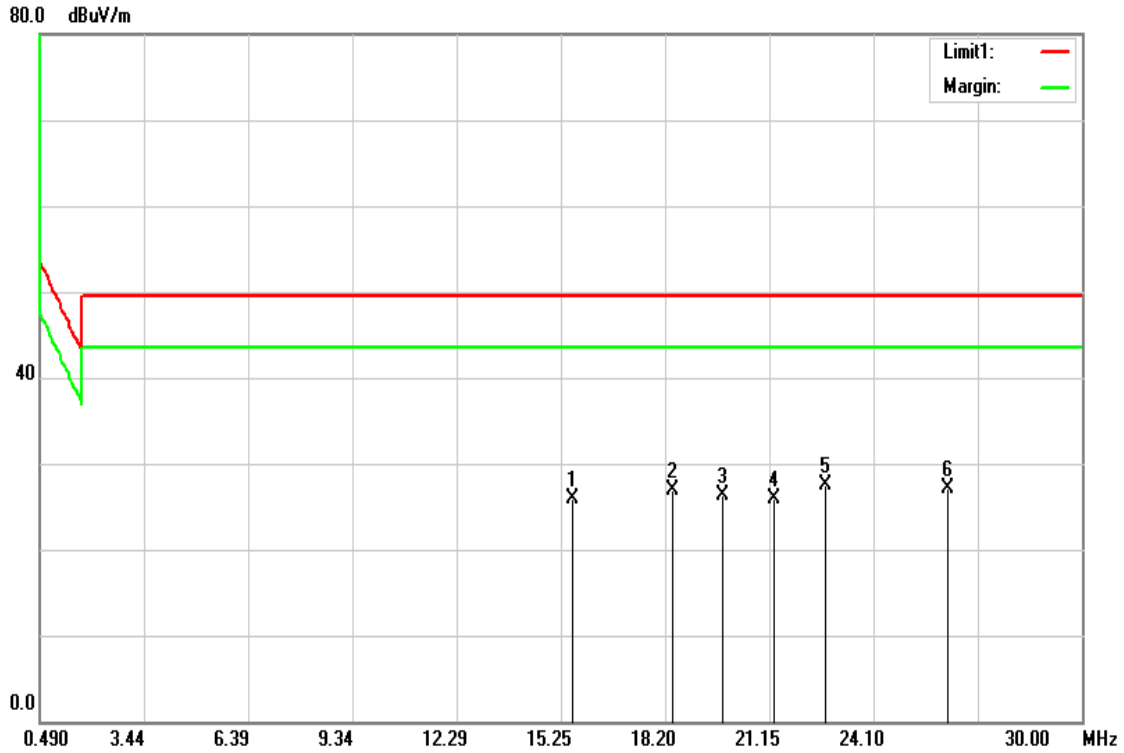

Frequency (MHz)	Reading (dBuV)	Correction Factor (dB/m)	Result (dBuV/m)	Limit (dBuV/m)	Margin (dB)	Detector Mode (PK/QP/AVG)
15.5696	10.60	15.25	25.85	49.54	-23.69	peak
18.4026	11.56	15.31	26.87	49.54	-22.67	peak
19.8191	11.06	15.34	26.40	49.54	-23.14	peak
21.2650	10.82	15.11	25.93	49.54	-23.61	peak
22.7405	12.76	14.83	27.59	49.54	-21.95	peak
26.1932	12.96	14.19	27.15	49.54	-22.39	peak

30MHz ~ 1GHz
Operation Mode: TX mode

Test Date: December 1, 2017

Temperature: 24°C

Tested by: Jerry Chuang

Humidity: 33 % RH

Frequency (MHz)	Reading (dBuV)	Correction Factor (dB/m)	Result (dBuV/m)	Limit 3m (dBuV/m)	Margin (dB)	Detector Mode (PK/QP/AVG)
460.6800	45.41	-9.36	36.05	46.02	-9.97	peak
501.4200	44.21	-8.46	35.75	46.02	-10.27	peak
528.5800	46.48	-7.95	38.53	46.02	-7.49	peak
555.7400	47.22	-7.47	39.75	46.02	-6.27	peak
582.9000	42.00	-7.15	34.85	46.02	-11.17	peak
963.1400	37.42	-1.04	36.38	54.00	-17.62	peak
353.0100	56.61	-12.89	43.72	46.02	-2.30	QP
380.1700	51.34	-12.02	39.32	46.02	-6.70	QP
800.1800	44.70	-3.38	41.32	46.02	-4.70	QP
827.3400	44.75	-3.10	41.65	46.02	-4.37	QP
854.5000	44.14	-2.79	41.35	46.02	-4.67	QP
881.6600	43.80	-2.33	41.47	46.02	-4.55	QP

Vertical

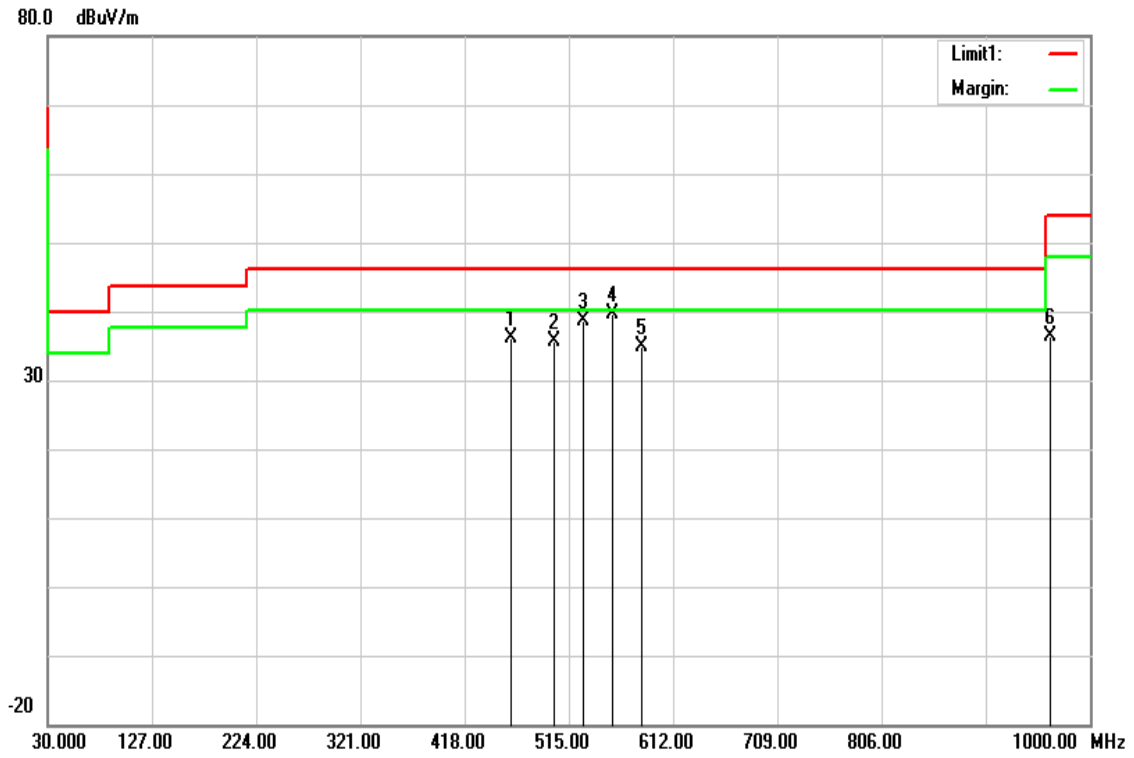

Horizontal

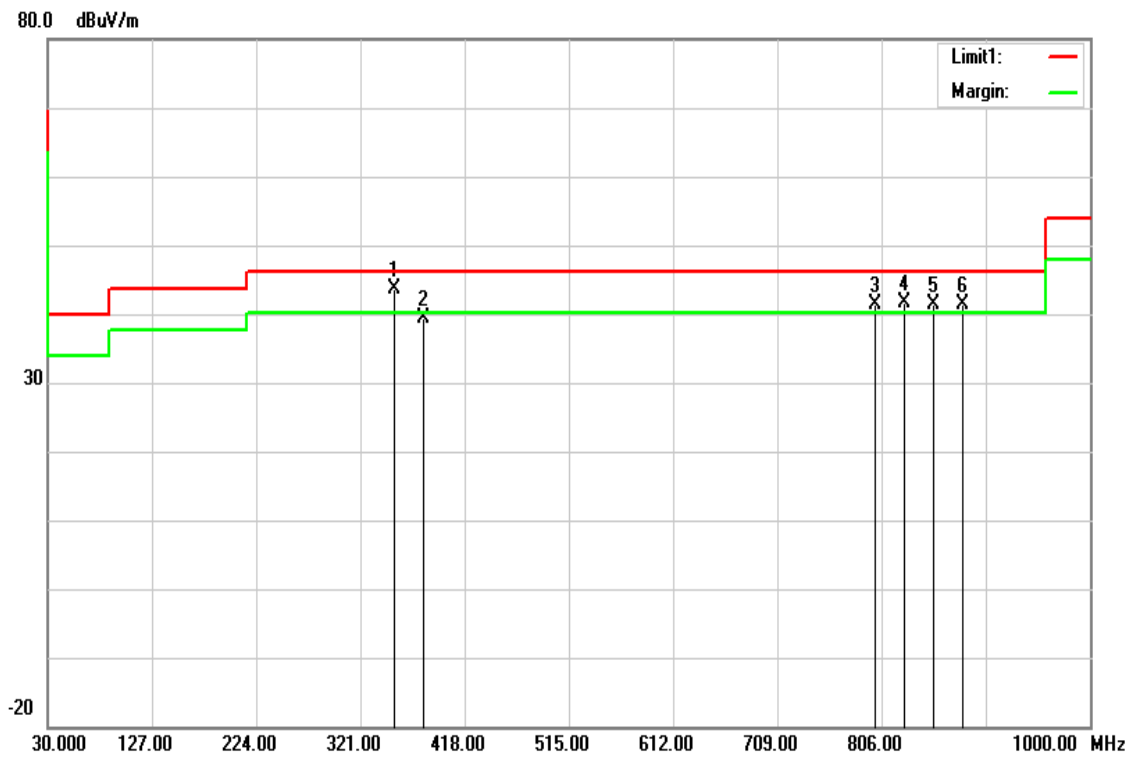

7.3 FREQUENCY STABILITY

LIMIT

According to §15.225(e), the frequency tolerance of the carrier signal shall be maintained within +/- 0.01% of the operating frequency over a temperature variation of -20 degrees to +50 degrees C at normal supply voltage, and for a variation in the primary supply voltage from 85% to 115% of the rated supply voltage at a temperature of 20 degrees C. For battery operated equipment, the equipment tests shall be performed using a new battery.

Test Configuration

Temperature and Voltage Measurement (under normal and extreme test conditions)

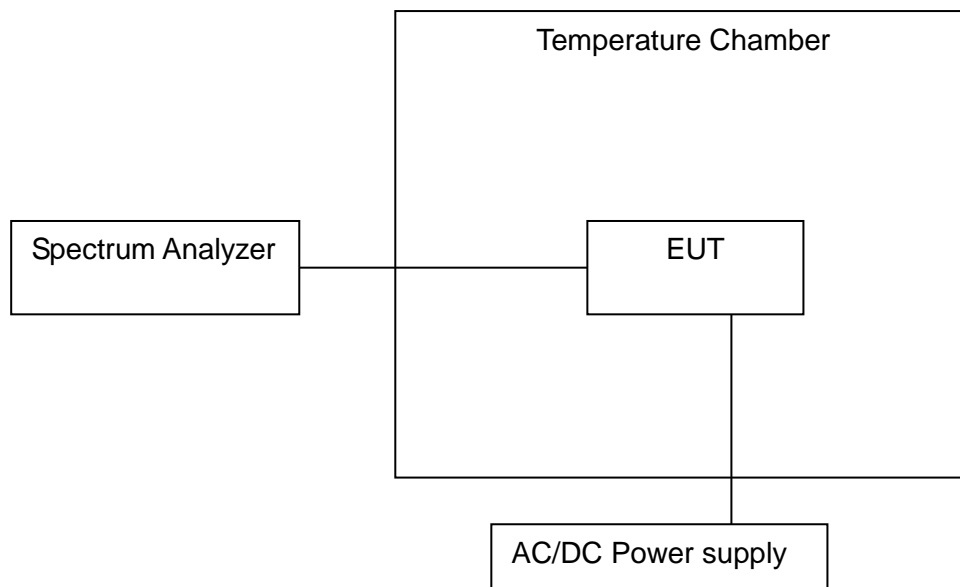

TEST PROCEDURE

1. Turn the EUT off, and place it inside the environmental temperature chamber.
2. Set the temperature control on the chamber to the highest specified in the regulatory requirements for the type of device and allow the oscillator heater and the chamber temperature to stabilize.
3. Set the spectrum analyzer as RBW=1kHz, VBW = RBW, Span = 200kHz, Sweep = auto.
4. Turn the EUT on and record the operating frequency at startup and two, five, and ten minutes after the EUT is energized.
5. Switch off the EUT and Lower the chamber temperature by not more than 10 °C and allow the temperature inside the chamber to stabilize.
6. Mark the peak frequency and measure the frequency tolerance using frequency counter function.
7. Repeat step 4 through step 6 down to the lowest specified temperature.

TEST RESULTS

No non-compliance noted.

TEST DATA

Condition			Frequency Error (ppm)									
Temperature	Modulation Mode	Test Freq.	0 min	2 min	5 min	10 min	0 min	2 min	5 min	10 min	Limit (ppm)	Result
Normal												
T _{20°C} V _{max}	CW	13.56	13.560478	13.560492	13.560492	13.560507	35.25	36.28	36.28	37.39	100	Pass
T _{20°C} V _{min}	CW	13.56	13.560478	13.560493	13.560489	13.560507	35.25	36.36	36.06	37.39		Pass
Extreme												
T _{50°C} V _{nom}	CW	13.56	13.560471	13.560474	13.560472	13.560477	34.73	34.96	34.81	35.18	100	Pass
T _{40°C} V _{nom}	CW	13.56	13.560481	13.560482	13.560482	13.560484	35.47	35.55	35.55	35.69		Pass
T _{30°C} V _{nom}	CW	13.56	13.560479	13.560477	13.560472	13.560474	35.32	35.18	34.81	34.96		Pass
T _{20°C} V _{nom}	CW	13.56	13.560478	13.560474	13.560475	13.560473	35.25	34.96	35.03	34.88		Pass
T _{10°C} V _{nom}	CW	13.56	13.560477	13.560471	13.560475	13.560478	35.18	34.73	35.03	35.25		Pass
T _{0°C} V _{nom}	CW	13.56	13.560478	13.560479	13.560480	13.560477	35.25	35.32	35.40	35.18		Pass
T _{-10°C} V _{nom}	CW	13.56	13.560480	13.560409	13.560472	13.560476	35.40	30.16	34.81	35.10		Pass
T _{-20°C} V _{nom}	CW	13.56	13.560479	13.560478	13.560479	13.560472	35.32	35.25	35.32	34.81		Pass

Remark: V_{nom}: 5
 V_{max}: 5.5
 V_{min}: 4.5

7.4 POWERLINE CONDUCTED EMISSIONS

LIMIT

According to §15.207(a), for an intentional radiator that is designed to be connected to the public utility (AC) power line, the radio frequency voltage that is conducted back onto the AC power line on any frequency or frequencies within the band 150 kHz to 30 MHz shall not exceed the limits in the following table, as measured using a 50 µH/50 ohms line impedance stabilization network (LISN). Compliance with the provisions of this paragraph shall be based on the measurement of the radio frequency voltage between each power line and ground at the power terminal. The lower limit applies at the boundary between the frequency ranges.

Frequency Range (MHz)	Limits (dBµV)	
	Quasi-peak	Average
0.15 to 0.50	66 to 56*	56 to 46*
0.50 to 5	56	46
5 to 30	60	50

* Decreases with the logarithm of the frequency.

TEST PROCEDURE

1. The EUT was placed on a table, which is 0.8m above ground plane.
2. Maximum procedure was performed on the six highest emissions to ensure EUT compliance.
3. Repeat above procedures until all frequency measured were complete.

Test Plots

Conducted emissions (Line 1)

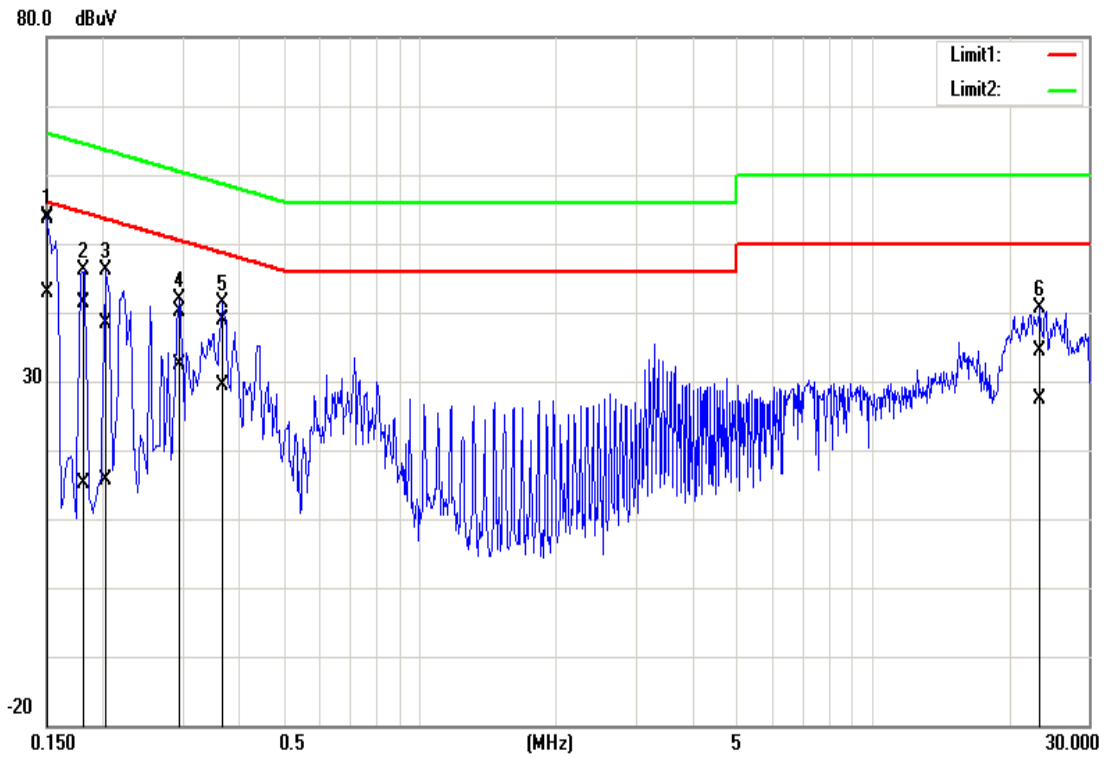

Conducted emissions (Line 2)

