

# RF TEST REPORT

**Applicant** ID TECH  
**FCC ID** WQJ-VP7200L  
**Product** VP7200  
**Brand** ID TECH  
**Model** ID72-818; ID72-818D; ID72-810; ID72-810D;  
ID72-018; ID72-018D; ID72-010; ID72-010D;  
**Report No.** R2301A0058-R1  
**Issue Date** June 1, 2023

TA Technology (Shanghai) Co., Ltd. tested the above equipment in accordance with the requirements in **FCC CFR47 Part 2 (2022)/ FCC CFR 47 Part 22H (2022)**. The test results show that the equipment tested is capable of demonstrating compliance with the requirements as documented in this report.

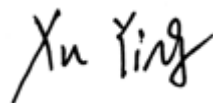

Prepared by: Xu Ying



Approved by: Xu Kai

---

**TA Technology (Shanghai) Co., Ltd.**

Building 3, No.145, Jintang Rd, Pudong Shanghai, P.R.China

TEL: +86-021-50791141/2/3

FAX: +86-021-50791141/2/3-8000

## TABLE OF CONTENT

1. Test Laboratory .....	4
1.1. Notes of the Test Report .....	4
1.2. Test Facility .....	4
1.3. Testing Location .....	4
2. General Description of Equipment Under Test .....	5
2.1. Applicant and Manufacturer Information .....	5
2.2. General Information .....	5
3. Applied Standards .....	7
4. Test Configuration .....	8
5. Test Case .....	9
5.1. RF Power Output and Effective Radiated Power .....	9
5.2. Radiated Spurious Emission .....	10
6. Test Result .....	13
6.1. RF Power Output and Effective Radiated Power .....	13
6.2. Radiated Spurious Emission .....	20
7. Main Test Instruments .....	24
ANNEX A: The EUT Appearance .....	25
ANNEX B: Test Setup Photos .....	26

## Summary of Measurement Results

No.	Test Case	Clause in FCC rules	Verdict
1	RF Power Output and Effective Radiated Power	2.1046 22.913(a)(5)	PASS
2	Radiated Spurious Emission	2.1053 / 22.917 (a)	PASS
Date of Testing: January 17, 2023 ~ March 9, 2023 Date of Sample Received: January 16, 2023			
Note: PASS: The EUT complies with the essential requirements in the standard. FAIL: The EUT does not comply with the essential requirements in the standard. All indications of Pass/Fail in this report are opinions expressed by TA Technology (Shanghai) Co., Ltd. based on interpretations and/or observations of test results. Measurement Uncertainties were not taken into account and are published for informational purposes only.			

**Only Radiated Spurious Emission is tested for VP7200 in this report, and because of the change of antenna gain, Effective Isotropic Radiated Power also re evaluated. Other test items refer to the Module report (FCC ID: XMR202008EG91NAXD; Report No.: R2006A0379-R1 and R2006A0379-R4).**

## 1. Test Laboratory

### 1.1. Notes of the Test Report

This report shall not be reproduced in full or partial, without the written approval of **TA Technology (Shanghai) Co., Ltd.** The results documented in this report apply only to the tested sample, under the conditions and modes of operation as described herein. Measurement Uncertainties were not taken into account and are published for informational purposes only. This report is written to support regulatory compliance of the applicable standards stated above.

### 1.2. Test Facility

#### **FCC (Designation number: CN1179, Test Firm Registration Number: 446626)**

TA Technology (Shanghai) Co., Ltd. has been listed on the US Federal Communications Commission list of test facilities recognized to perform measurements.

#### **A2LA (Certificate Number: 3857.01)**

TA Technology (Shanghai) Co., Ltd. has been listed by American Association for Laboratory Accreditation to perform measurement.

### 1.3. Testing Location

Company: TA Technology (Shanghai) Co., Ltd.  
Address: Building 3, No.145, Jintang Rd, Pudong Shanghai, P.R.China  
City: Shanghai  
Post code: 201201  
Country: P. R. China  
Contact: Xu Kai  
Telephone: +86-021-50791141/2/3  
Fax: +86-021-50791141/2/3-8000  
Website: <http://www.ta-shanghai.com>  
E-mail: [xukai@ta-shanghai.com](mailto:xukai@ta-shanghai.com)

## 2. General Description of Equipment Under Test

### 2.1. Applicant and Manufacturer Information

Applicant	ID TECH
Applicant address	10721 Walker Street, Cypress, California 90630, United States
Manufacturer	ID TECH TAIWAN
Manufacturer address	No. 16, Lane 22, GaoQing Rd., YanMei Dist., TaoYuan City 326, Taiwan

### 2.2. General Information

EUT Description			
Model	ID72-818; ID72-818D; ID72-810; ID72-810D; ID72-018; ID72-018D; ID72-010; ID72-010D;		
SN	252T027671		
Hardware Version	Rev.A		
Software Version	v1.00		
Power Supply	External power supply		
Antenna Type	External Antenna		
Antenna Gain	1.5dBi		
Test Mode(s)	WCDMA Band V; LTE Band 5/26;		
Test Modulation	(WCDMA) BPSK, QPSK; (LTE) QPSK, 16QAM;		
HSDPA UE Category	24		
HSUPA UE Category	6		
DC-HSDPA UE Category	24		
LTE Category	1		
Maximum E.R.P.	WCDMA Band V:	22.47 dBm	
	LTE Band 5:	23.58 dBm	
	LTE Band 26:	23.40 dBm	
Rated Power Supply Voltage	5V		
Operating Voltage	Minimum: 4.75V    Maximum: 5.25V		
Operating Temperature	Lowest: -35°C    Highest: +70°C		
Operating Frequency Range(s)	Band	Tx (MHz)	Rx (MHz)
	WCDMA Band V	824 ~ 849	869 ~ 894
	LTE Band 5	824 ~ 849	869 ~ 894
	LTE Band 26	824 ~ 849	869 ~ 894
Note: 1. The EUT is sent from the applicant to TA and the information of the EUT is declared by the applicant.			

Model No:	camera	Ethernet	Others
ID72-818; ID72-818D (This two models just have difference key)	YES	YES	All the same
ID72-018; ID72-018D (This two models just have difference key)	NO	YES	
ID72-810; ID72-810D (This two models just have difference key)	YES	NO	
ID72-010; ID72-010D (This two models just have difference key)	NO	NO	
Note: 1. The key is related to the transaction. 2. This report only tests ID72-818D.			

### 3. Applied Standards

According to the specifications of the manufacturer, it must comply with the requirements of the following standards:

**Test standards:**

**FCC CFR 47 Part 22H (2022)**

**FCC CFR47 Part 2 (2022)**

**Reference standard:**

**ANSI C63.26-2015**

**KDB 971168 D01 Power Meas License Digital Systems v03r01**

## 4. Test Configuration

Radiated measurements are performed by rotating the EUT in three different orthogonal test planes. EUT stand-up position (Z axis), lie-down position (X, Y axis). Receiver antenna polarization (horizontal and vertical), the worst emission was found in position (X axis, vertical polarization for WCDMA; Y axis, horizontal polarization for LTE) and the worst case was recorded.

All mode and data rates and positions and RB size and modulations were investigated.

Subsequently, only the worst case emissions are reported.

The following testing in WCDMA/LTE is set based on the maximum RF Output Power.

Test modes are chosen to be reported as the worst case configuration below:

Test items	Modes/Modulation
	WCDMA Band V
RF Power Output and Effective Radiated power	RMC HSDPA/HSUPA DC-HSDPA
Radiated Spurious Emission	RMC

Test modes are chosen as the worst case configuration below for LTE Band 5/26

Test items	Modes	Bandwidth (MHz)					Modulation		RB			Test Channel		
		1.4	3	5	10	15	QPSK	16QAM	1	50%	100%	L	M	H
RF power output and Effective Radiated power	LTE 5	O	O	O	O	-	O	O	O	O	O	O	O	O
	LTE 26	O	O	O	O	O	O	O	O	O	O	O	O	O
Radiated Spurious Emission	LTE 5	O	-	O	O	-	O	-	O	-	-	-	O	-
	LTE 26	O	-	O	-	O	O	-	O	-	-	-	O	-
Note	1. The mark "O" means that this configuration is chosen for testing. 2. The mark "-" means that this configuration is not testing.													



## 5. Test Case

### 5.1. RF Power Output and Effective Radiated Power

#### Ambient Condition

Temperature	Relative humidity
20°C ~25°C	45%~50%

#### Methods of Measurement

During the process of the testing, The EUT was connected to the Base Station Simulator with a known loss. The EUT is controlled by the Base Station Simulator test set to ensure max power transmission with proper modulation.

ERP can then be calculated as follows:

$EIRP \text{ (dBm)} = \text{Output Power (dBm)} + \text{Antenna Gain (dBi)}$

$EIRP \text{ (dBm)} = ERP \text{ (dBm)} + 2.15 \text{ (dB)}$ .

#### Test Setup

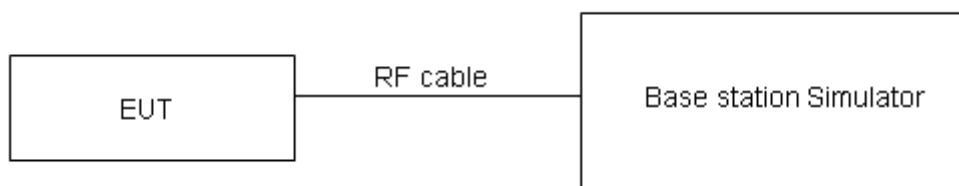

#### Limits

No specific RF power output requirements in part 2.1046.

Rule Part 22.913(a)(5) specifies that "Mobile/portable stations are limited to 7 watts ERP".

Limit	$\leq 7 \text{ W}$ (38.45 dBm)
-------	--------------------------------

#### Measurement Uncertainty

The assessed measurement uncertainty to ensure 95% confidence level for the normal distribution is with the coverage factor  $k = 2$ ,  $U = 0.4 \text{ dB}$  for RF power output,  $k = 2$ ,  $U = 1.19 \text{ dB}$  for ERP.

#### Test Results

Refer to the section 6.1 of this report for test data.

## 5.2. Radiated Spurious Emission

### Ambient Condition

Temperature	Relative humidity
20°C ~25°C	45%~50%

### Method of Measurement

- The testing follows FCC KDB 971168 v03r01 Section 5.8 and ANSI C63.26-2015.
- Below 1GHz: The EUT is placed on a turntable 0.8 meters above the ground in the chamber, 3 meter away from the antenna. The maximal emission value is acquired by adjusting the antenna height, polarisation and turntable azimuth. Normally, the height range of antenna is 1 m to 4 m, the azimuth range of turntable is 0° to 360°, and the receive antenna has two polarizations Vertical (V) and Horizontal (H). Above 1GHz: (Note: the FCC's permission to use 1.5m as an alternative per TCBC Conf call of Dec. 2, 2014.) The EUT is placed on a turntable 1.5 meters above the ground in the chamber, 3 meter away from the antenna. The maximal emission value is acquired by adjusting the antenna height, polarisation and turntable azimuth. Normally, the height range of antenna is 1 m to 4 m, the azimuth range of turntable is 0° to 360°, and the receive antenna has two polarizations Vertical (V) and Horizontal (H).
- A loop antenna, A log-periodic antenna or horn antenna shall be substituted in place of the EUT. The log-periodic antenna will be driven by a signal generator and the level will be adjusted till the same power value on the spectrum analyzer or receiver. The level of the spurious emissions can be calculated through the level of the signal generator, cable loss, the gain of the substitution antenna and the reading of the spectrum analyzer or receiver.
- The EUT is then put into continuously transmitting mode at its maximum power level during the test. Set Test Receiver or Spectrum RBW=100kHz, VBW=300kHz, and the maximum value of the receiver should be recorded as (Pr).
- The EUT shall be replaced by a substitution antenna. In the chamber, an substitution antenna for the frequency band of interest is placed at the reference point of the chamber. An RF Signal source for the frequency band of interest is connected to the substitution antenna with a cable that has been constructed to not interfere with the radiation pattern of the antenna. A power (PMea) is applied to the input of the substitution antenna, and adjust the level of the signal generator output until the value of the receiver reach the previously recorded (Pr). The power of signal source (PMea) is recorded. The test should be performed by rotating the test item and adjusting the receiving antenna polarization.
- A amplifier should be connected to the Signal Source output port. And the cable should be connect between the Amplifier and the Substitution Antenna. The cable loss (Pcl) ,the Substitution Antenna Gain (Ga) and the Amplifier Gain (PAg) should be recorded after test.
- The measurement results are obtained as described below:  
 Power (EIRP) = PMea - PAg - Pcl + Ga  
 The measurement results are amend as described below:  
 Power (EIRP) = PMea - Pcl + Ga
- This value is EIRP since the measurement is calibrated using an antenna of known gain (2.15 dB) and known input power. ERP can be calculated from EIRP by subtracting the gain of the dipole, ERP = EIRP-2.15dB.  
 The modulation mode and RB allocation refer to section 5.1, using the maximum output power

configuration.

**Test Setup**

**9KHz~ 30MHz**

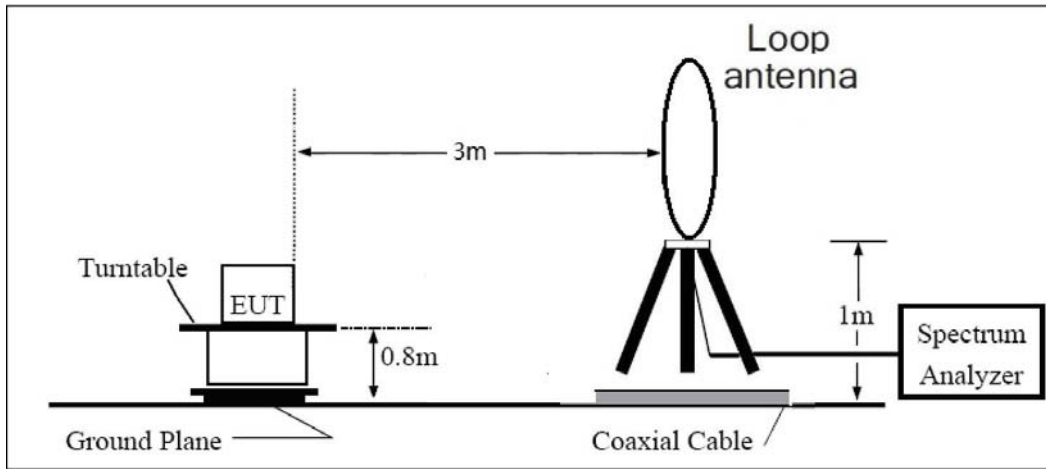

**30MHz~ 1GHz**

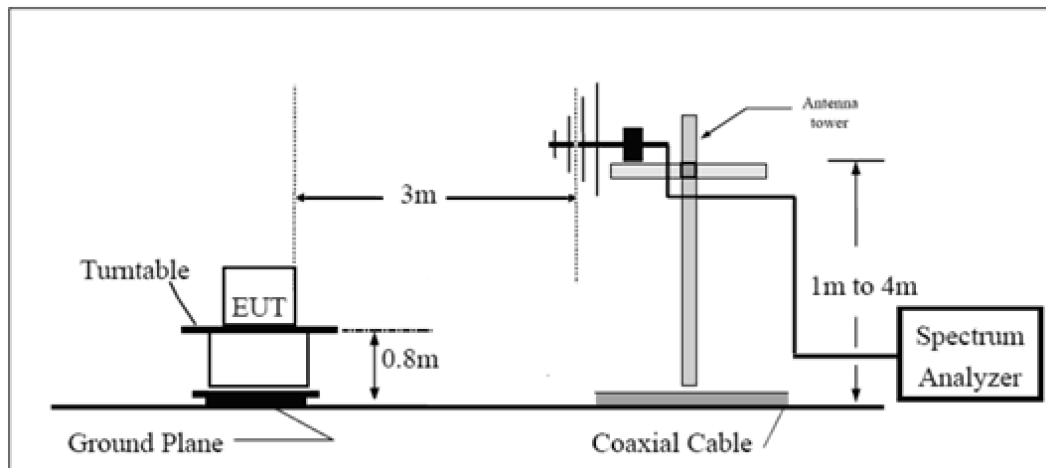

**Above 1GHz**

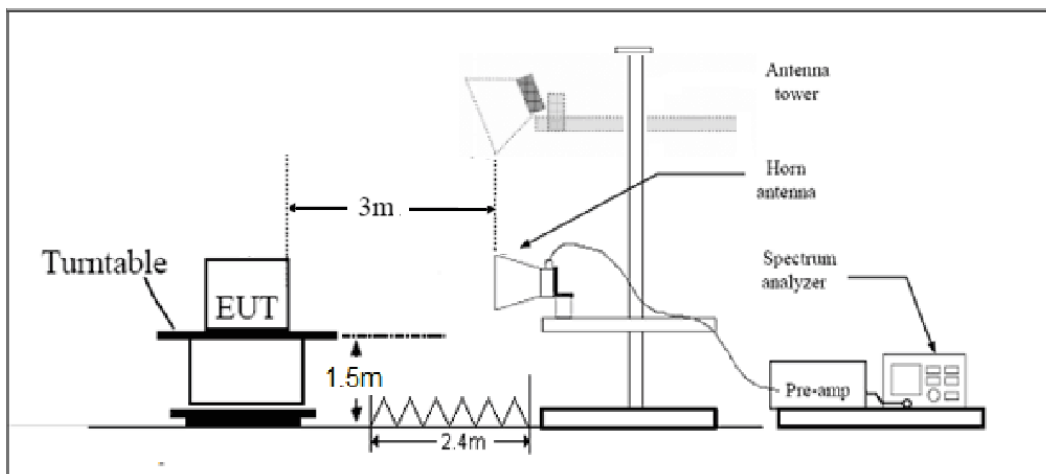

Note: Area side: 2.4mX3.6m

### Limits

Rule Part 22.917(a) specifies that “The power of any emission outside of the authorized operating frequency ranges must be attenuated below the transmitting power (P) by a factor of at least  $43 + 10 \log (P)$  Db.”

Limit	-13 dBm
-------	---------

### Measurement Uncertainty

The assessed measurement uncertainty to ensure 95% confidence level for the normal distribution is with the coverage factor  $k = 1.96$ ,  $U = 3.55$  Db.

### Test Results

Refer to the section 6.2 of this report for test data.

## 6. Test Result

### 6.1. RF Power Output and Effective Radiated Power

WCDMA Band V		Maximum Output Power (dBm)			ERP (dBm)		
		Channel 4132	Channel 4183	Channel 4233	Channel 4132	Channel 4183	Channel 4233
		826.4 (MHz)	836.6 (MHz)	846.6 (MHz)	826.4 (MHz)	836.6 (MHz)	846.6 (MHz)
RMC	12.2k	23.06	22.99	23.12	22.41	22.34	22.47
	64k	22.99	22.85	23.06	22.34	22.20	22.41
	144k	22.98	22.84	22.96	22.33	22.19	22.31
	384k	22.97	22.83	22.95	22.32	22.18	22.30
HSDPA	Sub - Test 1	22.79	22.64	22.69	22.14	21.99	22.04
	Sub - Test 2	22.75	22.68	22.78	22.10	22.03	22.13
	Sub - Test 3	22.39	22.32	22.3	21.74	21.67	21.65
	Sub - Test 4	22.31	22.25	22.26	21.66	21.60	21.61
HSUPA	Sub - Test 1	22.82	22.74	22.75	22.17	22.09	22.10
	Sub - Test 2	22.31	22.26	22.29	21.66	21.61	21.64
	Sub - Test 3	22.76	22.78	22.75	22.11	22.13	22.10
	Sub - Test 4	22.77	22.71	22.76	22.12	22.06	22.11
	Sub - Test 5	22.73	22.76	22.71	22.08	22.11	22.06
DC-HSDPA	Sub - Test 1	22.93	22.86	22.99	22.28	22.21	22.34
	Sub - Test 2	23.02	22.84	22.98	22.37	22.19	22.33
	Sub - Test 3	22.51	22.33	22.47	21.86	21.68	21.82
	Sub - Test 4	22.5	22.32	22.46	21.85	21.67	21.81

LTE Band 5				Conducted Power(dBm)			ERP (dBm)		
BW	Modulation	RB	RB	Channel/Frequency(MHz)			Channel/Frequency(MHz)		
		size	offset	20407/ 824.7	20525/ 836.5	20643/ 848.3	20407/ 824.7	20525/ 836.5	20643/ 848.3
1.4MHz	QPSK	1	0	23.83	23.93	23.87	23.18	23.28	23.22
		1	2	23.97	24.02	24.23	23.32	23.37	23.58
		1	5	23.76	23.94	23.92	23.11	23.29	23.27
		3	0	23.83	23.77	24.04	23.18	23.12	23.39
		3	2	23.81	23.79	24.03	23.16	23.14	23.38
		3	3	23.87	23.84	23.98	23.22	23.19	23.33
	6	0	22.86	22.86	22.95	22.21	22.21	22.30	
	16QAM	1	0	23.44	22.82	22.85	22.79	22.17	22.20
	1	2	23.47	23.03	23.04	22.82	22.38	22.39	

BW	Modulation	RB size	RB offset	Channel/Frequency(MHz)			Channel/Frequency(MHz)		
				20415/ 825.5	20415/ 825.5	20415/ 825.5	20415/ 825.5	20415/ 825.5	20415/ 825.5
3MHz	QPSK	1	0	23.95	24.06	23.83	23.30	23.41	23.18
		1	7	24.19	24.10	24.01	23.54	23.45	23.36
		1	14	23.79	23.77	23.96	23.14	23.12	23.31
		8	0	23.13	23.07	22.92	22.48	22.42	22.27
		8	4	22.92	23.01	22.96	22.27	22.36	22.31
		8	7	22.97	23.01	23.05	22.32	22.36	22.40
	16QAM	15	0	23.09	23.07	23.04	22.44	22.42	22.39
		1	0	22.73	23.28	23.55	22.08	22.63	22.90
		1	7	23.04	23.61	24.09	22.39	22.96	23.44
5MHz	QPSK	1	0	23.94	24.02	23.81	23.29	23.37	23.16
		1	13	24.17	24.09	23.98	23.52	23.44	23.33
		1	24	23.76	23.72	23.92	23.11	23.07	23.27
		12	0	23.11	23.03	22.89	22.46	22.38	22.24
		12	6	22.89	22.96	22.92	22.24	22.31	22.27
		12	13	22.94	22.98	23.01	22.29	22.33	22.36
	16QAM	25	0	23.07	23.03	22.99	22.42	22.38	22.34
		1	0	22.68	23.26	23.53	22.03	22.61	22.88
		1	13	23.02	23.58	24.07	22.37	22.93	23.42
10MHz	QPSK	1	0	23.91	23.98	23.78	23.26	23.33	23.13
		1	25	24.16	24.05	23.96	23.51	23.40	23.31
		1	49	23.74	23.71	23.89	23.09	23.06	23.24
		25	0	23.08	22.98	22.85	22.43	22.33	22.20
		25	13	22.87	22.92	22.89	22.22	22.27	22.24
		25	25	22.91	22.93	22.97	22.26	22.28	22.32
	16QAM	50	0	23.04	22.98	22.95	22.39	22.33	22.30
		1	0	22.66	23.22	23.48	22.01	22.57	22.83
		1	25	22.98	23.56	24.03	22.33	22.91	23.38
		1	49	22.77	23.14	23.48	22.12	22.49	22.83

Band	Bandwidth	Modulation	Channel	RB Configuration	Conducted Power(dBm)	ERP(dBm)
LTE Band 26	1.4M	QPSK	26797	1RB#0	24.03	23.38
LTE Band 26	1.4M	QPSK	26797	1RB#2	23.84	23.19
LTE Band 26	1.4M	QPSK	26797	1RB#5	23.67	23.02
LTE Band 26	1.4M	QPSK	26797	3RB#0	22.86	22.21
LTE Band 26	1.4M	QPSK	26797	3RB#2	22.82	22.17
LTE Band 26	1.4M	QPSK	26797	3RB#3	22.85	22.20
LTE Band 26	1.4M	QPSK	26797	6RB#0	22.74	22.09
LTE Band 26	1.4M	QPSK	26915	1RB#0	23.71	23.06
LTE Band 26	1.4M	QPSK	26915	1RB#2	23.77	23.12
LTE Band 26	1.4M	QPSK	26915	1RB#5	23.74	23.09
LTE Band 26	1.4M	QPSK	26915	3RB#0	22.75	22.10
LTE Band 26	1.4M	QPSK	26915	3RB#2	22.73	22.08
LTE Band 26	1.4M	QPSK	26915	3RB#3	22.67	22.02
LTE Band 26	1.4M	QPSK	26915	6RB#0	22.73	22.08
LTE Band 26	1.4M	QPSK	27033	1RB#0	23.58	22.93
LTE Band 26	1.4M	QPSK	27033	1RB#2	23.61	22.96
LTE Band 26	1.4M	QPSK	27033	1RB#5	23.54	22.89
LTE Band 26	1.4M	QPSK	27033	3RB#0	22.66	22.01
LTE Band 26	1.4M	QPSK	27033	3RB#2	22.67	22.02
LTE Band 26	1.4M	QPSK	27033	3RB#3	22.66	22.01
LTE Band 26	1.4M	QPSK	27033	6RB#0	22.69	22.04
LTE Band 26	1.4M	16QAM	26797	1RB#0	23.00	22.35
LTE Band 26	1.4M	16QAM	26797	1RB#2	23.23	22.58
LTE Band 26	1.4M	16QAM	26797	1RB#5	23.29	22.64
LTE Band 26	1.4M	16QAM	26797	3RB#0	21.61	20.96
LTE Band 26	1.4M	16QAM	26797	3RB#2	21.58	20.93
LTE Band 26	1.4M	16QAM	26797	3RB#3	21.62	20.97
LTE Band 26	1.4M	16QAM	26797	6RB#0	21.75	21.10
LTE Band 26	1.4M	16QAM	26915	1RB#0	22.44	21.79
LTE Band 26	1.4M	16QAM	26915	1RB#2	22.38	21.73
LTE Band 26	1.4M	16QAM	26915	1RB#5	22.49	21.84
LTE Band 26	1.4M	16QAM	26915	3RB#0	21.70	21.05
LTE Band 26	1.4M	16QAM	26915	3RB#2	21.72	21.07
LTE Band 26	1.4M	16QAM	26915	3RB#3	21.71	21.06
LTE Band 26	1.4M	16QAM	26915	6RB#0	21.79	21.14
LTE Band 26	1.4M	16QAM	27033	1RB#0	22.15	21.50
LTE Band 26	1.4M	16QAM	27033	1RB#2	22.35	21.70
LTE Band 26	1.4M	16QAM	27033	1RB#5	22.00	21.35
LTE Band 26	1.4M	16QAM	27033	3RB#0	21.42	20.77
LTE Band 26	1.4M	16QAM	27033	3RB#2	21.48	20.83

LTE Band 26	1.4M	16QAM	27033	3RB#3	21.49	20.84
LTE Band 26	1.4M	16QAM	27033	6RB#0	21.72	21.07
LTE Band 26	3M	QPSK	26805	1RB#0	24.05	23.40
LTE Band 26	3M	QPSK	26805	1RB#7	23.87	23.22
LTE Band 26	3M	QPSK	26805	1RB#14	23.70	23.05
LTE Band 26	3M	QPSK	26805	8RB#0	22.94	22.29
LTE Band 26	3M	QPSK	26805	8RB#4	22.92	22.27
LTE Band 26	3M	QPSK	26805	8RB#7	22.93	22.28
LTE Band 26	3M	QPSK	26805	15RB#0	22.77	22.12
LTE Band 26	3M	QPSK	26915	1RB#0	23.75	23.10
LTE Band 26	3M	QPSK	26915	1RB#7	23.82	23.17
LTE Band 26	3M	QPSK	26915	1RB#14	23.79	23.14
LTE Band 26	3M	QPSK	26915	8RB#0	22.85	22.20
LTE Band 26	3M	QPSK	26915	8RB#4	22.81	22.16
LTE Band 26	3M	QPSK	26915	8RB#7	22.76	22.11
LTE Band 26	3M	QPSK	26915	15RB#0	22.77	22.12
LTE Band 26	3M	QPSK	27025	1RB#0	23.61	22.96
LTE Band 26	3M	QPSK	27025	1RB#7	23.65	23.00
LTE Band 26	3M	QPSK	27025	1RB#14	23.58	22.93
LTE Band 26	3M	QPSK	27025	8RB#0	22.77	22.12
LTE Band 26	3M	QPSK	27025	8RB#4	22.77	22.12
LTE Band 26	3M	QPSK	27025	8RB#7	22.74	22.09
LTE Band 26	3M	QPSK	27025	15RB#0	22.72	22.07
LTE Band 26	3M	16QAM	26805	1RB#0	23.03	22.38
LTE Band 26	3M	16QAM	26805	1RB#7	23.26	22.61
LTE Band 26	3M	16QAM	26805	1RB#14	23.31	22.66
LTE Band 26	3M	16QAM	26805	8RB#0	21.70	21.05
LTE Band 26	3M	16QAM	26805	8RB#4	21.67	21.02
LTE Band 26	3M	16QAM	26805	8RB#7	21.70	21.05
LTE Band 26	3M	16QAM	26805	15RB#0	21.78	21.13
LTE Band 26	3M	16QAM	26915	1RB#0	22.46	21.81
LTE Band 26	3M	16QAM	26915	1RB#7	22.43	21.78
LTE Band 26	3M	16QAM	26915	1RB#14	22.53	21.88
LTE Band 26	3M	16QAM	26915	8RB#0	21.81	21.16
LTE Band 26	3M	16QAM	26915	8RB#4	21.83	21.18
LTE Band 26	3M	16QAM	26915	8RB#7	21.81	21.16
LTE Band 26	3M	16QAM	26915	15RB#0	21.83	21.18
LTE Band 26	3M	16QAM	27025	1RB#0	22.18	21.53
LTE Band 26	3M	16QAM	27025	1RB#7	22.39	21.74
LTE Band 26	3M	16QAM	27025	1RB#14	22.03	21.38
LTE Band 26	3M	16QAM	27025	8RB#0	21.52	20.87
LTE Band 26	3M	16QAM	27025	8RB#4	21.58	20.93
LTE Band 26	3M	16QAM	27025	8RB#7	21.60	20.95



LTE Band 26	3M	16QAM	27025	15RB#0	21.75	21.10
LTE Band 26	5M	QPSK	26815	1RB#0	24.00	23.35
LTE Band 26	5M	QPSK	26815	1RB#13	23.85	23.20
LTE Band 26	5M	QPSK	26815	1RB#24	23.64	22.99
LTE Band 26	5M	QPSK	26815	12RB#0	22.89	22.24
LTE Band 26	5M	QPSK	26815	12RB#6	22.88	22.23
LTE Band 26	5M	QPSK	26815	12RB#13	22.87	22.22
LTE Band 26	5M	QPSK	26815	25RB#0	22.78	22.13
LTE Band 26	5M	QPSK	26915	1RB#0	23.66	23.01
LTE Band 26	5M	QPSK	26915	1RB#13	23.78	23.13
LTE Band 26	5M	QPSK	26915	1RB#24	23.72	23.07
LTE Band 26	5M	QPSK	26915	12RB#0	22.76	22.11
LTE Band 26	5M	QPSK	26915	12RB#6	22.73	22.08
LTE Band 26	5M	QPSK	26915	12RB#13	22.70	22.05
LTE Band 26	5M	QPSK	26915	25RB#0	22.69	22.04
LTE Band 26	5M	QPSK	27015	1RB#0	23.55	22.90
LTE Band 26	5M	QPSK	27015	1RB#13	23.61	22.96
LTE Band 26	5M	QPSK	27015	1RB#24	23.50	22.85
LTE Band 26	5M	QPSK	27015	12RB#0	22.70	22.05
LTE Band 26	5M	QPSK	27015	12RB#6	22.69	22.04
LTE Band 26	5M	QPSK	27015	12RB#13	22.67	22.02
LTE Band 26	5M	QPSK	27015	25RB#0	22.65	22.00
LTE Band 26	5M	16QAM	26815	1RB#0	22.95	22.30
LTE Band 26	5M	16QAM	26815	1RB#13	23.20	22.55
LTE Band 26	5M	16QAM	26815	1RB#24	23.26	22.61
LTE Band 26	5M	16QAM	26815	12RB#0	21.65	21.00
LTE Band 26	5M	16QAM	26815	12RB#6	21.60	20.95
LTE Band 26	5M	16QAM	26815	12RB#13	21.65	21.00
LTE Band 26	5M	16QAM	26815	25RB#0	21.74	21.09
LTE Band 26	5M	16QAM	26915	1RB#0	22.39	21.74
LTE Band 26	5M	16QAM	26915	1RB#13	22.40	21.75
LTE Band 26	5M	16QAM	26915	1RB#24	22.46	21.81
LTE Band 26	5M	16QAM	26915	12RB#0	21.76	21.11
LTE Band 26	5M	16QAM	26915	12RB#6	21.75	21.10
LTE Band 26	5M	16QAM	26915	12RB#13	21.72	21.07
LTE Band 26	5M	16QAM	26915	25RB#0	21.75	21.10
LTE Band 26	5M	16QAM	27015	1RB#0	22.10	21.45
LTE Band 26	5M	16QAM	27015	1RB#13	22.33	21.68
LTE Band 26	5M	16QAM	27015	1RB#24	21.97	21.32
LTE Band 26	5M	16QAM	27015	12RB#0	21.47	20.82
LTE Band 26	5M	16QAM	27015	12RB#6	21.50	20.85
LTE Band 26	5M	16QAM	27015	12RB#13	21.53	20.88
LTE Band 26	5M	16QAM	27015	25RB#0	21.67	21.02

LTE Band 26	10M	QPSK	26840	1RB#0	23.83	23.18
LTE Band 26	10M	QPSK	26840	1RB#25	23.81	23.16
LTE Band 26	10M	QPSK	26840	1RB#49	23.75	23.10
LTE Band 26	10M	QPSK	26840	25RB#0	22.79	22.14
LTE Band 26	10M	QPSK	26840	25RB#13	22.81	22.16
LTE Band 26	10M	QPSK	26840	25RB#25	22.85	22.20
LTE Band 26	10M	QPSK	26840	50RB#0	22.93	22.28
LTE Band 26	10M	QPSK	26915	1RB#0	23.82	23.17
LTE Band 26	10M	QPSK	26915	1RB#25	23.77	23.12
LTE Band 26	10M	QPSK	26915	1RB#49	23.63	22.98
LTE Band 26	10M	QPSK	26915	25RB#0	22.78	22.13
LTE Band 26	10M	QPSK	26915	25RB#13	22.73	22.08
LTE Band 26	10M	QPSK	26915	25RB#25	22.71	22.06
LTE Band 26	10M	QPSK	26915	50RB#0	22.75	22.10
LTE Band 26	10M	QPSK	26990	1RB#0	23.64	22.99
LTE Band 26	10M	QPSK	26990	1RB#25	23.88	23.23
LTE Band 26	10M	QPSK	26990	1RB#49	23.60	22.95
LTE Band 26	10M	QPSK	26990	25RB#0	22.75	22.10
LTE Band 26	10M	QPSK	26990	25RB#13	22.74	22.09
LTE Band 26	10M	QPSK	26990	25RB#25	22.73	22.08
LTE Band 26	10M	QPSK	26990	50RB#0	22.76	22.11
LTE Band 26	10M	16QAM	26840	1RB#0	23.01	22.36
LTE Band 26	10M	16QAM	26840	1RB#25	23.46	22.81
LTE Band 26	10M	16QAM	26840	1RB#49	23.02	22.37
LTE Band 26	10M	16QAM	26840	25RB#0	21.85	21.20
LTE Band 26	10M	16QAM	26840	25RB#13	21.81	21.16
LTE Band 26	10M	16QAM	26840	25RB#25	21.84	21.19
LTE Band 26	10M	16QAM	26915	1RB#0	23.40	22.75
LTE Band 26	10M	16QAM	26915	1RB#25	23.22	22.57
LTE Band 26	10M	16QAM	26915	1RB#49	23.10	22.45
LTE Band 26	10M	16QAM	26915	25RB#0	21.66	21.01
LTE Band 26	10M	16QAM	26915	25RB#13	21.73	21.08
LTE Band 26	10M	16QAM	26915	25RB#25	21.82	21.17
LTE Band 26	10M	16QAM	26990	1RB#0	23.36	22.71
LTE Band 26	10M	16QAM	26990	1RB#25	23.31	22.66
LTE Band 26	10M	16QAM	26990	1RB#49	22.99	22.34
LTE Band 26	10M	16QAM	26990	25RB#0	21.82	21.17
LTE Band 26	10M	16QAM	26990	25RB#13	21.78	21.13
LTE Band 26	10M	16QAM	26990	25RB#25	21.69	21.04
LTE Band 26	15M	QPSK	26865	1RB#0	23.79	23.14
LTE Band 26	15M	QPSK	26865	1RB#38	24.02	23.37
LTE Band 26	15M	QPSK	26865	1RB#74	23.78	23.13
LTE Band 26	15M	QPSK	26865	36RB#0	22.90	22.25

LTE Band 26	15M	QPSK	26865	36RB#18	22.85	22.20
LTE Band 26	15M	QPSK	26865	36RB#39	22.82	22.17
LTE Band 26	15M	QPSK	26865	75RB#0	22.80	22.15
LTE Band 26	15M	QPSK	26915	1RB#0	23.75	23.10
LTE Band 26	15M	QPSK	26915	1RB#38	23.58	22.93
LTE Band 26	15M	QPSK	26915	1RB#74	23.59	22.94
LTE Band 26	15M	QPSK	26915	36RB#0	22.87	22.22
LTE Band 26	15M	QPSK	26915	36RB#18	22.81	22.16
LTE Band 26	15M	QPSK	26915	36RB#39	22.74	22.09
LTE Band 26	15M	QPSK	26915	75RB#0	22.78	22.13
LTE Band 26	15M	QPSK	26965	1RB#0	23.66	23.01
LTE Band 26	15M	QPSK	26965	1RB#38	23.54	22.89
LTE Band 26	15M	QPSK	26965	1RB#74	23.50	22.85
LTE Band 26	15M	QPSK	26965	36RB#0	22.69	22.04
LTE Band 26	15M	QPSK	26965	36RB#18	22.72	22.07
LTE Band 26	15M	QPSK	26965	36RB#39	22.70	22.05
LTE Band 26	15M	QPSK	26965	75RB#0	22.75	22.10
LTE Band 26	15M	16QAM	26865	1RB#0	22.52	21.87
LTE Band 26	15M	16QAM	26865	1RB#38	22.60	21.95
LTE Band 26	15M	16QAM	26865	1RB#74	22.62	21.97
LTE Band 26	15M	16QAM	26915	1RB#0	23.38	22.73
LTE Band 26	15M	16QAM	26915	1RB#38	23.27	22.62
LTE Band 26	15M	16QAM	26915	1RB#74	23.03	22.38
LTE Band 26	15M	16QAM	26965	1RB#0	22.55	21.90
LTE Band 26	15M	16QAM	26965	1RB#38	22.46	21.81
LTE Band 26	15M	16QAM	26965	1RB#74	22.34	21.69

## 6.2. Radiated Spurious Emission

Sweep the whole frequency band through the range from 9kHz to the 10th harmonic of the carrier, the emissions below the noise floor will not be recorded in the report.

WCDMA Band V CH-Middle

Harmonic	Frequency (MHz)	SG (dBm)	Cable Loss (dB)	Gain (dBi)	Antenna Polarization	ERP Level (dBm)	Limit (dBm)	Margin (dB)	Azimuth (deg)
2	1671.20	-63.25	1.70	8.70	Vertical	-58.40	-13.00	45.40	45
3	2510.40	-60.99	2.30	12.00	Vertical	-53.44	-13.00	40.44	135
4	3346.40	-65.17	2.70	12.70	Vertical	-57.32	-13.00	44.32	135
5	4183.00	-60.93	3.00	12.50	Vertical	-53.58	-13.00	40.58	45
6	5019.60	-59.75	3.40	12.50	Vertical	-52.80	-13.00	39.80	0
7	5856.20	-59.20	3.40	12.80	Vertical	-51.95	-13.00	38.95	135
8	6692.80	-57.78	4.10	11.50	Vertical	-52.53	-13.00	39.53	90
9	7529.40	-57.38	4.20	12.20	Vertical	-51.53	-13.00	38.53	135
10	8366.00	-56.63	4.30	12.50	Vertical	-50.58	-13.00	37.58	45

Note: 1. The other Spurious RF Radiated emissions level is no more than noise floor.  
2. The worst emission was found in the antenna is Vertical position.

LTE Band 5 1.4MHz CH-Middle

Harmonic	Frequency (MHz)	SG (dBm)	Cable Loss (dB)	Gain (dBi)	Antenna Polarization	ERP Level (dBm)	Limit (dBm)	Margin (dB)	Azimuth (deg)
2	1673.00	-49.77	1.70	8.70	Horizontal	-44.92	-13.00	31.92	135
3	2509.50	-42.81	2.30	12.00	Horizontal	-35.26	-13.00	22.26	45
4	3344.20	-63.48	2.70	12.70	Horizontal	-55.63	-13.00	42.63	315
5	4180.30	-58.50	3.00	12.50	Horizontal	-51.15	-13.00	38.15	180
6	5019.00	-62.06	3.40	12.50	Horizontal	-55.11	-13.00	42.11	45
7	5855.50	-61.47	3.40	12.80	Horizontal	-54.22	-13.00	41.22	0
8	6692.00	-56.88	4.10	11.50	Horizontal	-51.63	-13.00	38.63	315
9	7528.50	-55.56	4.20	12.20	Horizontal	-49.71	-13.00	36.71	45
10	8365.00	-55.86	4.30	12.50	Horizontal	-49.81	-13.00	36.81	0

Note: 1. The other Spurious RF Radiated emissions level is no more than noise floor.  
2. The worst emission was found in the antenna is Horizontal position.

LTE Band 5 5MHz CH-Middle

Harmonic	Frequency (MHz)	SG (dBm)	Cable Loss (dB)	Gain (dBi)	Antenna Polarization	ERP Level (dBm)	Limit (dBm)	Margin (dB)	Azimuth (deg)
2	1668.60	-49.81	1.70	8.70	Horizontal	-44.96	-13.00	31.96	225
3	2503.30	-42.12	2.30	12.00	Horizontal	-34.57	-13.00	21.57	90
4	3337.20	-65.21	2.70	12.70	Horizontal	-57.36	-13.00	44.36	45
5	4171.80	-61.09	3.00	12.50	Horizontal	-53.74	-13.00	40.74	315
6	5006.25	-61.81	3.40	12.50	Horizontal	-54.86	-13.00	41.86	180
7	5840.63	-61.73	3.40	12.80	Horizontal	-54.48	-13.00	41.48	45
8	6675.00	-60.26	4.10	11.50	Horizontal	-55.01	-13.00	42.01	315
9	7509.38	-57.46	4.20	12.20	Horizontal	-51.61	-13.00	38.61	270
10	8343.75	-57.24	4.30	12.50	Horizontal	-51.19	-13.00	38.19	225

Note: 1. The other Spurious RF Radiated emissions level is no more than noise floor.  
 2. The worst emission was found in the antenna is Horizontal position.

LTE Band 5 10MHz CH-Middle

Harmonic	Frequency (MHz)	SG (dBm)	Cable Loss (dB)	Gain (dBi)	Antenna Polarization	ERP Level (dBm)	Limit (dBm)	Margin (dB)	Azimuth (deg)
2	1664.40	-50.58	1.70	8.70	Horizontal	-45.73	-13.00	32.73	45
3	2496.60	-46.55	2.30	12.00	Horizontal	-39.00	-13.00	26.00	135
4	3346.00	-65.21	2.70	12.70	Horizontal	-57.36	-13.00	44.36	315
5	4182.90	-61.64	3.00	12.50	Horizontal	-54.29	-13.00	41.29	180
6	4989.00	-61.99	3.40	12.50	Horizontal	-55.04	-13.00	42.04	0
7	5820.50	-62.06	3.40	12.80	Horizontal	-54.81	-13.00	41.81	315
8	6652.00	-60.18	4.10	11.50	Horizontal	-54.93	-13.00	41.93	90
9	7483.50	-56.72	4.20	12.20	Horizontal	-50.87	-13.00	37.87	180
10	8315.00	-55.57	4.30	12.50	Horizontal	-49.52	-13.00	36.52	45

Note: 1. The other Spurious RF Radiated emissions level is no more than noise floor.  
 2. The worst emission was found in the antenna is Horizontal position.

LTE Band 26 1.4MHz CH-Middle

Harmonic	Frequency (MHz)	SG (dBm)	Cable Loss (dB)	Gain (dBi)	Antenna Polarization	ERP Level (dBm)	Limit (dBm)	Margin (dB)	Azimuth (deg)
2	1673.00	-51.83	1.70	8.70	Horizontal	-46.98	-13.00	33.98	45
3	2509.50	-47.46	2.30	12.00	Horizontal	-39.91	-13.00	26.91	135
4	3344.20	-63.84	2.70	12.70	Horizontal	-55.99	-13.00	42.99	0
5	4179.90	-60.65	3.00	12.50	Horizontal	-53.30	-13.00	40.30	45
6	5019.00	-60.35	3.40	12.50	Horizontal	-53.40	-13.00	40.40	0
7	5855.50	-59.34	3.40	12.80	Horizontal	-52.09	-13.00	39.09	315
8	6692.00	-55.70	4.10	11.50	Horizontal	-50.45	-13.00	37.45	180
9	7528.50	-56.10	4.20	12.20	Horizontal	-50.25	-13.00	37.25	0
10	8365.00	-55.80	4.30	12.50	Horizontal	-49.75	-13.00	36.75	315

Note: 1. The other Spurious RF Radiated emissions level is no more than noise floor.  
 2. The worst emission was found in the antenna is Horizontal position.

LTE Band 26 5MHz CH-Middle

Harmonic	Frequency (MHz)	SG (dBm)	Cable Loss (dB)	Gain (dBi)	Antenna Polarization	ERP Level (dBm)	Limit (dBm)	Margin (dB)	Azimuth (deg)
2	1668.00	-51.22	1.70	8.70	Horizontal	-46.37	-13.00	33.37	45
3	2502.00	-46.77	2.30	12.00	Horizontal	-39.22	-13.00	26.22	45
4	3337.60	-64.81	2.70	12.70	Horizontal	-56.96	-13.00	43.96	180
5	4171.80	-59.70	3.00	12.50	Horizontal	-52.35	-13.00	39.35	90
6	5004.00	-61.57	3.40	12.50	Horizontal	-54.62	-13.00	41.62	0
7	5838.00	-61.78	3.40	12.80	Horizontal	-54.53	-13.00	41.53	45
8	6672.00	-60.60	4.10	11.50	Horizontal	-55.35	-13.00	42.35	315
9	7506.00	-57.45	4.20	12.20	Horizontal	-51.60	-13.00	38.60	0
10	8340.00	-55.84	4.30	12.50	Horizontal	-49.79	-13.00	36.79	315

Note: 1. The other Spurious RF Radiated emissions level is no more than noise floor.  
 2. The worst emission was found in the antenna is Horizontal position.

## LTE Band 26 10MHz CH-Middle

Harmonic	Frequency (MHz)	SG (dBm)	Cable Loss (dB)	Gain (dBi)	Antenna Polarization	ERP Level (dBm)	Limit (dBm)	Margin (dB)	Azimuth (deg)
2	1658.00	-51.30	1.70	8.70	Horizontal	-46.45	-13.00	33.45	45
3	2487.00	-42.42	2.30	12.00	Horizontal	-34.87	-13.00	21.87	225
4	3319.30	-65.42	2.70	12.70	Horizontal	-57.57	-13.00	44.57	180
5	4149.30	-58.16	3.00	12.50	Horizontal	-50.81	-13.00	37.81	45
6	4974.00	-62.18	3.40	12.50	Horizontal	-55.23	-13.00	42.23	0
7	5803.00	-61.73	3.40	12.80	Horizontal	-54.48	-13.00	41.48	315
8	6666.90	-58.22	4.10	11.50	Horizontal	-52.97	-13.00	39.97	180
9	7461.00	-57.18	4.20	12.20	Horizontal	-51.33	-13.00	38.33	315
10	8290.00	-57.82	4.30	12.50	Horizontal	-51.77	-13.00	38.77	45

Note: 1. The other Spurious RF Radiated emissions level is no more than noise floor.

2. The worst emission was found in the antenna is Horizontal position.

## 7. Main Test Instruments

Name	Manufacturer	Type	Serial Number	Calibration Date	Expiration Date
Signal Analyzer	R&S	FSV30	100815	2022-12-10	2023-12-09
TRILOG Broadband Antenna	Schwarzbeck	VULB 9163	391	2022-09-29	2025-09-28
Horn Antenna	Schwarzbeck	BBHA 9120D	1594	2020-12-17	2023-12-16
Software	R&S	EMC32	10.35.10	/	/

\*\*\*\*\*END OF REPORT \*\*\*\*\*



## ANNEX A: The EUT Appearance

The EUT Appearance is submitted separately.

## ANNEX B: Test Setup Photos

The Test Setup Photos is submitted separately.