

RF TEST REPORT

Applicant ID TECH
FCC ID WQJ-VP6825LE
Product VP6825
Brand ID TECH
Model VP6825-8101; VP6825-8101D
Report No. R2307A0810-R3V1
Issue Date August 22, 2023

TA Technology (Shanghai) Co., Ltd. tested the above equipment in accordance with the requirements in **FCC CFR47 Part 2 (2022)/ FCC CFR47 Part 27C (2022)**. The test results show that the equipment tested is capable of demonstrating compliance with the requirements as documented in this report.

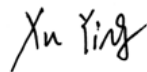

Prepared by: Xu Ying



Approved by: Xu Kai

TA Technology (Shanghai) Co., Ltd.

Building 3, No.145, Jintang Rd, Pudong Shanghai, P.R.China

TEL: +86-021-50791141/2/3

FAX: +86-021-50791141/2/3-8000

TABLE OF CONTENT

1	Test Laboratory.....	5
1.1	Notes of the Test Report.....	5
1.2.	Test facility.....	5
1.3	Testing Location.....	5
2	General Description of Equipment under Test.....	6
2.1	Applicant and Manufacturer Information.....	6
2.2	General information.....	6
3	Applied Standards.....	8
4	Test Configuration.....	9
5	Test Case.....	10
5.1	RF Power Output and Effective Isotropic Radiated Power.....	10
5.2	Radiated Spurious Emission.....	12
6	Test Results.....	15
6.1	RF Power Output and Effective Isotropic Radiated Power.....	15
6.2	Radiated Spurious Emission.....	20
7	Main Test Instruments.....	25
	ANNEX A: The EUT Appearance.....	26
	ANNEX B: Test Setup Photos.....	27

Version	Revision description	Issue Date
Rev.0	Initial issue of report.	August 8, 2023
Rev.1	Update description.	August 22, 2023
<p>Note: This revised report (Report No.: R2307A0810-R3V1) supersedes and replaces the previously issued report (Report No.: R2307A0810-R3). Please discard or destroy the previously issued report and dispose of it accordingly.</p>		

Summary of Measurement Results

Number	Test Case	Clause in FCC rules	Verdict
1	RF Power Output and Effective Isotropic Radiated Power	2.1046 /27.50(d)(4) /27.50(b)(10) /27.50(c)(10)	PASS
2	Radiated Spurious Emission	2.1053 /27.53(h) /27.53(g) /27.53(f) /27.53(c)	PASS
Date of Testing: July 18, 2023 ~ July 25, 2023 Date of Sample Received: July 14, 2023			
Note: PASS: The EUT complies with the essential requirements in the standard. FAIL: The EUT does not comply with the essential requirements in the standard. All indications of Pass/Fail in this report are opinions expressed by TA Technology (Shanghai) Co., Ltd. based on interpretations and/or observations of test results. Measurement Uncertainties were not taken into account and are published for informational purposes only.			

This report only tested Radiated Spurious Emission, and because of the change of antenna gain, Effective Isotropic Radiated Power also re evaluated.

Other test items refer to the module report (FCC ID: XMR202008EG91NAXD; Report No.: R2006A0379-R5).

1 Test Laboratory

1.1 Notes of the Test Report

This report shall not be reproduced in full or partial, without the written approval of **TA Technology (Shanghai) Co., Ltd.** The results documented in this report apply only to the tested sample, under the conditions and modes of operation as described herein. Measurement Uncertainties were not taken into account and are published for informational purposes only. This report is written to support regulatory compliance of the applicable standards stated above.

1.2. Test facility

FCC (Designation number: CN1179, Test Firm Registration Number: 446626)

TA Technology (Shanghai) Co., Ltd. has been listed on the US Federal Communications Commission list of test facilities recognized to perform measurements.

A2LA (Certificate Number: 3857.01)

TA Technology (Shanghai) Co., Ltd. has been listed by American Association for Laboratory Accreditation to perform measurement.

1.3 Testing Location

Company: TA Technology (Shanghai) Co., Ltd.
 Address: Building 3, No.145, Jintang Rd, Pudong Shanghai, P.R.China
 City: Shanghai
 Post code: 201201
 Country: P. R. China
 Contact: Xu Kai
 Telephone: +86-021-50791141/2/3
 Fax: +86-021-50791141/2/3-8000
 Website: <http://www.ta-shanghai.com>
 E-mail: xukai@ta-shanghai.com

2 General Description of Equipment under Test

2.1 Applicant and Manufacturer Information

Applicant	ID TECH
Applicant address	10721 Walker Street, Cypress, California 90630, United States
Manufacturer	ID TECH TAIWAN
Manufacturer address	No. 16, Lane 22, GaoQing Rd., YanMei Dist., TaoYuan City 326, Taiwan

2.2 General information

EUT Description			
Model	VP6825-8101; VP6825-8101D		
SN	305T039040		
Hardware Version	Rev.A		
Software Version	v1.00		
Power Supply	External power supply		
Antenna Type	External Antenna		
Antenna Gain	Frequency (MHz)	Gain(dBi)	
	WCDMA Band IV	0.9	
	LTE Band 4	0.9	
	LTE Band 12/13	1.7	
Test Mode(s)	WCDMA Band IV; LTE Band 4/12/13		
Test Modulation	(WCDMA) BPSK, QPSK, 16QAM; (LTE) QPSK, 16QAM		
HSDPA UE Category	10		
HSUPA UE Category	6		
DC-HSDPA UE Category	20		
HSPA+ UE Category	7		
LTE Category	1		
Maximum E.I.R.P./ E.R.P.	WCDMA Band IV	24.47 dBm	
	LTE Band 4	25.21 dBm	
	LTE Band 12	23.78 dBm	
	LTE Band 13	23.50 dBm	
Rated Power Supply Voltage	DC 5 V		
Operating Voltage	Minimum: 4.75V Maximum: 5.25V		
Operating Temperature	Lowest: -20°C Highest: 70°C		
Operating Frequency Range(s)	Mode	Tx (MHz)	Rx (MHz)
	WCDMA Band IV	1710 ~ 1755	2110 ~ 2155

	LTE Band 4	1710 ~ 1755	2110 ~ 2155
	LTE Band 12	699 ~ 716	729 ~ 746
	LTE Band 13	777 ~ 787	746 ~ 756

Note:

1. The EUT is sent from the applicant to TA and the information of the EUT is declared by the applicant.
2. VP6825-8101 and VP6825-8101D are the same except for different models, and this report only tests VP6825-8101.

3 Applied Standards

According to the specifications of the manufacturer, it must comply with the requirements of the following standards:

Test standards:

FCC CFR47 Part 27C (2022)

FCC CFR47 Part 2 (2022)

Reference standard:

ANSI C63.26-2015

KDB 971168 D01 Power Meas License Digital Systems v03r01

4 Test Configuration

Radiated measurements are performed by rotating the EUT in three different orthogonal test planes. EUT stand-up position (Z axis), lie-down position (X, Y axis). Receiver antenna polarization (horizontal and vertical), the worst emission was found in position (Y axis, horizontal polarization for WCDMA Band; X axis, vertical polarization for LTE Band) and the worst case was recorded.

All mode and data rates and positions and RB size and modulations were investigated. Subsequently, only the worst case emissions are reported.

The following testing in WCDMA/LTE is set based on the maximum RF Output Power.

The following testing in different Bandwidth is set to detail in the following table:

Test modes are chosen to be reported as the worst case configuration below:

Test items	Modes/Modulation
	WCDMA Band IV
RF Power Output and Effective Isotropic Radiated Power	RMC HSDPA/HSUPA/DC-HSDPA
Radiated Spurious Emission	RMC

Test modes are chosen to be reported as the worst case configuration below for LTE Band 4/12/13:

Test items	Modes	Bandwidth (MHz)						Modulation		RB			Test Channel		
		1.4	3	5	10	15	20	QPSK	16QAM	1	50%	100%	L	M	H
RF Power Output and Effective Isotropic Radiated Power	LTE 4	O	O	O	O	O	O	O	O	O	O	O	O	O	O
	LTE 12	O	O	O	O	-	-	O	O	O	O	O	O	O	O
	LTE 13	-	-	O	O	-	-	O	O	O	O	O	O	O	O
Radiated Spurious Emission	LTE 4	O	-	O	-	-	O	O	O	O	-	-	-	O	-
	LTE 12	O	-	O	O	-	-	O	O	O	-	-	-	O	-
	LTE 13	-	-	O	O	-	-	O	O	O	-	-	-	O	-
Note	1. The mark "O" means that this configuration is chosen for testing. 2. The mark "-" means that this configuration is not testing.														

5 Test Case

5.1 RF Power Output and Effective Isotropic Radiated Power

Ambient condition

Temperature	Relative humidity
20°C ~ 25°C	45% ~ 50%

Methods of Measurement

During the process of the testing, The EUT was connected to the Base Station Simulator with a known loss. The EUT is controlled by the Base Station Simulator test set to ensure max power transmission with proper modulation.

ERP can then be calculated as follows:

$$\text{EIRP (dBm)} = \text{Output Power (dBm)} + \text{Antenna Gain (dBi)}$$

$$\text{EIRP (dBm)} = \text{ERP (dBm)} + 2.15 \text{ (dB.)}$$

Test Setup

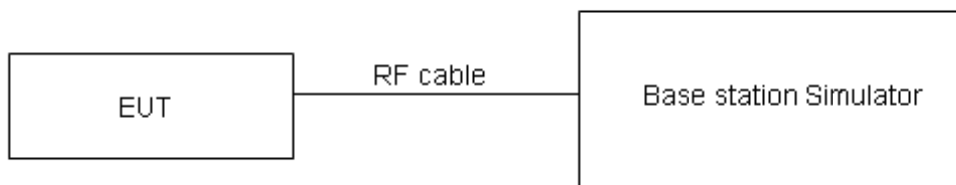

Limits

No specific RF power output requirements in part 2.1046.

Rule Part 27.50(b) (10) specifies that “Portable stations (hand-held devices) transmitting in the 746-757 MHz, 776-788 MHz, and 805-806 MHz bands are limited to 3 watts ERP”

Rule Part 27.50(c) (10) specifies that “Portable stations (hand-held devices) in the 600 MHz uplink band and the 698-746 MHz band, and fixed and mobile stations in the 600 MHz uplink band are limited to 3 watts ERP”

Rule Part 27.50(d) (4) specifies that “Fixed, mobile and portable (hand-held) stations operating in the 1710–1755 MHz band are limited to 1 watt EIRP”

Part 27.50(b)(10)Limit	≤ 3 W (34.77 dBm)
Part 27.50(c)(10)Limit	≤ 3 W (34.77 dBm)
Part 27.50(d)(4)Limit	≤ 1 W (30 dBm)

Measurement Uncertainty

The assessed measurement uncertainty to ensure 95% confidence level for the normal distribution is with the coverage factor $k = 2$, $U=0.4$ dB for RF power output, $k = 2$, $U= 1.19$ dB for ERP/EIRP.

Test Results

Refer to the section 6.1 of this report for test data.

5.2 Radiated Spurious Emission

Ambient condition

Temperature	Relative humidity
20°C ~ 25°C	45% ~ 50%

Method of Measurement

1. The testing follows FCC KDB 971168 D01 v03r01 Section 5.8 and ANSI C63.26-2015.
2. Below 1GHz: The EUT is placed on a turntable 0.8 meters above the ground in the chamber, 3 meter away from the antenna. The maximal emission value is acquired by adjusting the antenna height, polarisation and turntable azimuth. Normally, the height range of antenna is 1 m to 4 m, the azimuth range of turntable is 0° to 360°, and the receive antenna has two polarizations Vertical (V) and Horizontal (H). Above 1GHz: (Note: the FCC's permission to use 1.5m as an alternative per TCBC Conf call of Dec. 2, 2014.) The EUT is placed on a turntable 1.5 meters above the ground in the chamber, 3 meter away from the antenna. The maximal emission value is acquired by adjusting the antenna height, polarisation and turntable azimuth. Normally, the height range of antenna is 1 m to 4 m, the azimuth range of turntable is 0° to 360°, and the receive antenna has two polarizations Vertical (V) and Horizontal (H).
3. A loop antenna, A log-periodic antenna or horn antenna shall be substituted in place of the EUT. The log-periodic antenna will be driven by a signal generator and the level will be adjusted till the same power value on the spectrum analyzer or receiver. The level of the spurious emissions can be calculated through the level of the signal generator, cable loss, the gain of the substitution antenna and the reading of the spectrum analyzer or receiver.
4. The EUT is then put into continuously transmitting mode at its maximum power level during the test. Set Test Receiver or Spectrum RBW=100kHz, VBW=300kHz for 30MHz to 1GHz and RBW=1MHz, VBW=3MHz for above 1GHz, and the maximum value of the receiver should be recorded as (Pr).
5. The EUT shall be replaced by a substitution antenna. In the chamber, an substitution antenna for the frequency band of interest is placed at the reference point of the chamber. An RF Signal source for the frequency band of interest is connected to the substitution antenna with a cable that has been constructed to not interfere with the radiation pattern of the antenna. A power (PMea) is applied to the input of the substitution antenna, and adjust the level of the signal generator output until the value of the receiver reach the previously recorded (Pr). The power of signal source (PMea) is recorded. The test should be performed by rotating the test item and adjusting the receiving antenna polarization.
6. A amplifier should be connected to the Signal Source output port. And the cable should be connect between the Amplifier and the Substitution Antenna. The cable loss (Pcl) ,the Substitution Antenna Gain (Ga) and the Amplifier Gain (PAg) should be recorded after test.
7. The measurement results are obtained as described below:

$$\text{Power(EIRP)} = \text{PMea} - \text{PAg} - \text{Pcl} + \text{Ga}$$
 The measurement results are amend as described below:

$$\text{Power(EIRP)} = \text{PMea} - \text{Pcl} + \text{Ga}$$
8. This value is EIRP since the measurement is calibrated using an antenna of known gain (2.15 dB) and known input power. ERP can be calculated from EIRP by subtracting the gain of the dipole, ERP

= EIRP-2.15dB.

The modulation mode and RB allocation refer to section 5.1, using the maximum output power configuration.

Test setup

9KHz~ 30MHz

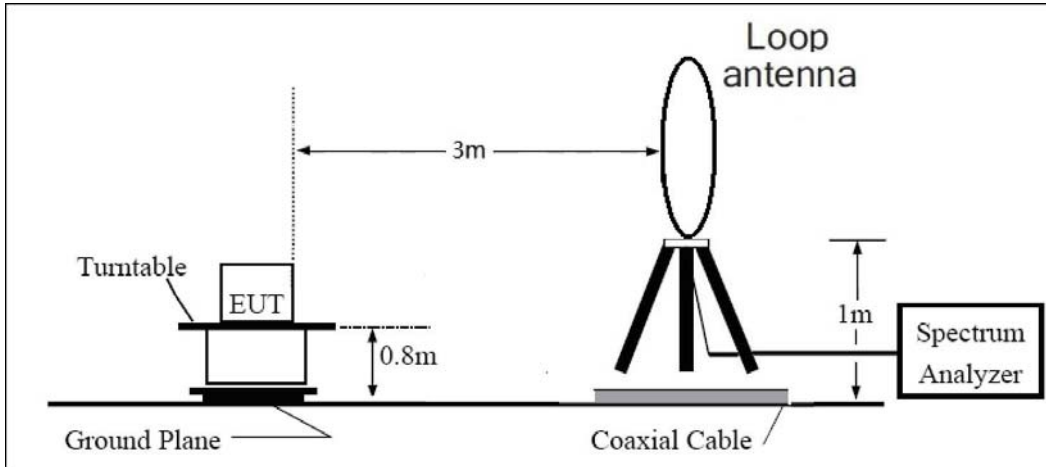

30MHz~ 1GHz

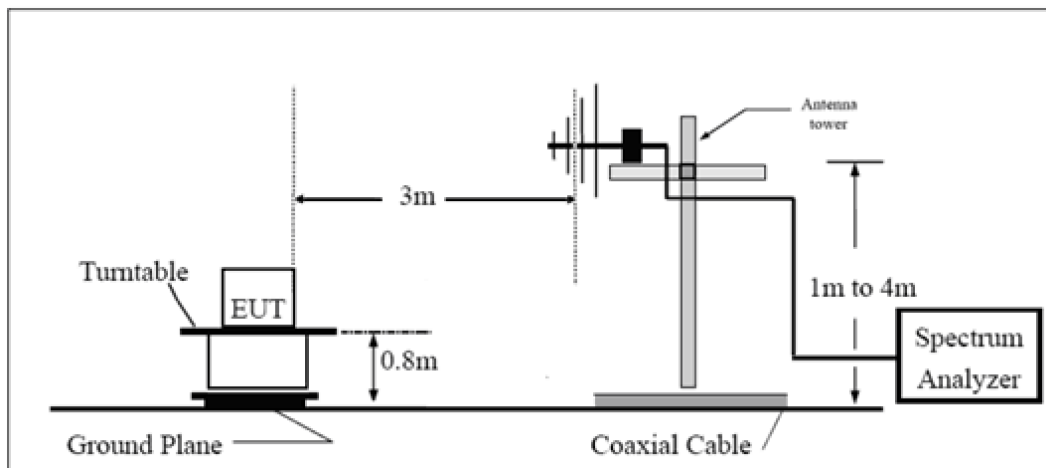

Above 1GHz

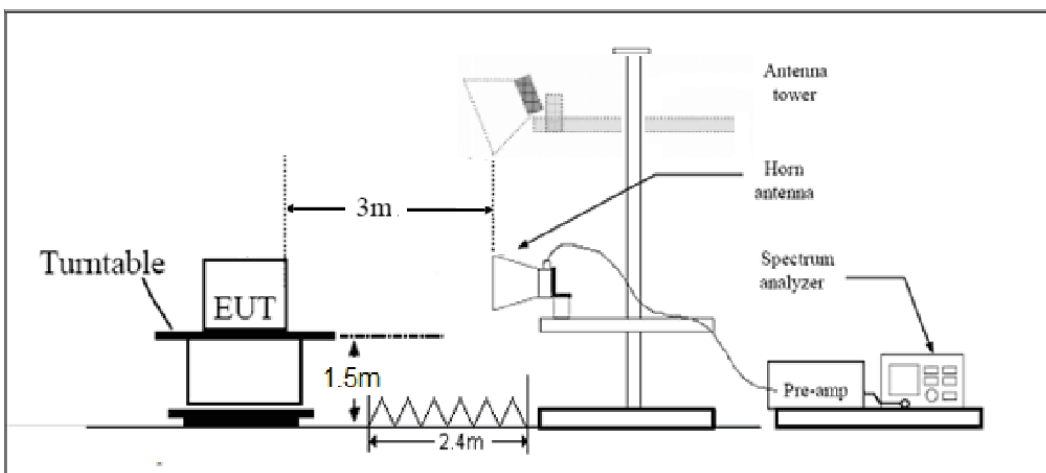

Note: Area side:2.4mX3.6m

Limits

Rule Part 27.53(h) specifies that “for operations in the 1695-1710 MHz, 1710-1755 MHz, 1755-1780 MHz, 1915-1920 MHz, 1995-2000 MHz, 2000-2020 MHz, 2110-2155 MHz, 2155-2180 MHz, and 2180-2200 bands, the power of any emission outside a licensee's frequency block shall be attenuated below the transmitter power (P) in watts by at least $43 + 10 \log_{10}(P)$ dB.”

Rule Part 27.53 (g) For operations in the 600 MHz band and the 698-746 MHz band, the power of any emission outside a licensee's frequency band(s) of operation shall be attenuated below the transmitter power (P) within the licensed band(s) of operation, measured in watts, by at least $43 + 10 \log(P)$ dB. Compliance with this provision is based on the use of measurement instrumentation employing a resolution bandwidth of 100 kilohertz or greater. However, in the 100 kilohertz bands immediately outside and adjacent to a licensee's frequency block, a resolution bandwidth of at least 30 kHz may be employed.

Rule Part 27.53(f) For operations in the 746-758 MHz, 775-788 MHz, and 805-806 MHz bands, emissions in the band 1559-1610 MHz shall be limited to -70 dBW/MHz equivalent isotropically radiated power (EIRP) for wideband signals, and -80 dBW EIRP for discrete emissions of less than 700 Hz bandwidth. For the purpose of equipment authorization, a transmitter shall be tested with an antenna that is representative of the type that will be used with the equipment in normal operation.

Part 27.53 (c) For operations in the 746-758 MHz band and the 776-788 MHz band, the power of any emission outside the licensee's frequency band(s) of operation shall be attenuated below the transmitter power (P) within the licensed band(s) of operation, measured in watts, in accordance with the following:

- (1) On any frequency outside the 746-758 MHz band, the power of any emission shall be attenuated outside the band below the transmitter power (P) by at least $43 + 10 \log(P)$ dB;
- (2) On any frequency outside the 776-788 MHz band, the power of any emission shall be attenuated outside the band below the transmitter power (P) by at least $43 + 10 \log(P)$ dB;
- (3) On all frequencies between 763-775 MHz and 793-805 MHz, by a factor not less than $76 + 10 \log(P)$ dB in a 6.25 kHz band segment, for base and fixed stations;
- (4) On all frequencies between 763-775 MHz and 793-805 MHz, by a factor not less than $65 + 10 \log(P)$ dB in a 6.25 kHz band segment, for mobile and portable stations;
- (5) Compliance with the provisions of paragraphs (c)(1) and (c)(2) of this section is based on the use of measurement instrumentation employing a resolution bandwidth of 100 kHz or greater. However, in the 100 kHz bands immediately outside and adjacent to the frequency block, a resolution bandwidth of at least 30 kHz may be employed;

Part 27.53 (h)/(g) Limit		-13 dBm
Part 27.53(f) Limit	Limit out of the band 1559-1610 MHz	-13 dBm
	Limit in the band 1559-1610 MHz	-40 dBm

Measurement Uncertainty

The assessed measurement uncertainty to ensure 95% confidence level for the normal distribution is with the coverage factor $k = \pm 1.96$, $U = \pm 3.55$ dB.

Test Results

Refer to the section 6.2 of this report for test data.

6 Test Results

6.1 RF Power Output and Effective Isotropic Radiated Power

WCDMA Band IV		Maximum Output Power (dBm)			EIRP (dBm)		
		Channel 1312	Channel 1413	Channel 1513	Channel 1312	Channel 1413	Channel 1513
		1712.4 (MHz)	1732.6 (MHz)	1752.6 (MHz)	1712.4 (MHz)	1732.6 (MHz)	1752.6 (MHz)
RMC	12.2k	23.57	23.56	23.51	24.47	24.46	24.41
	64k	23.43	23.50	23.38	24.33	24.40	24.28
	144k	23.42	23.40	23.37	24.32	24.30	24.27
	384k	23.41	23.39	23.36	24.31	24.29	24.26
HSDPA	Sub - Test 1	23.27	23.25	23.26	24.17	24.15	24.16
	Sub - Test 2	23.25	23.28	23.32	24.15	24.18	24.22
	Sub - Test 3	22.89	22.79	22.86	23.79	23.69	23.76
	Sub - Test 4	22.83	22.74	22.80	23.73	23.64	23.70
HSUPA	Sub - Test 1	23.32	23.25	23.30	24.22	24.15	24.20
	Sub - Test 2	22.84	22.81	22.80	23.74	23.71	23.70
	Sub - Test 3	23.32	23.31	23.27	24.22	24.21	24.17
	Sub - Test 4	23.31	23.29	23.36	24.21	24.19	24.26
	Sub - Test 5	23.26	23.16	23.25	24.16	24.06	24.15
DC-HSDPA	Sub - Test 1	23.44	23.43	23.38	24.34	24.33	24.28
	Sub - Test 2	23.42	23.42	23.37	24.32	24.32	24.27
	Sub - Test 3	22.91	22.91	22.86	23.81	23.81	23.76
	Sub - Test 4	22.90	22.90	22.85	23.80	23.80	23.75

LTE Band 4				Maximum Output Power (dBm)			EIRP (dBm)		
Bandwidth	Modulation	RB size	RB offset	Channel/ Frequency (MHz)			Channel/ Frequency (MHz)		
				19957/ 1710.7	20175/ 1732.5	20393/ 1754.3	19957/ 1710.7	20175/ 1732.5	20393/ 1754.3
1.4MHz	QPSK	1	0	23.94	24.08	23.88	24.84	24.98	24.78
		1	2	24.02	24.12	24.05	24.92	25.02	24.95
		1	5	24.13	24.25	23.87	25.03	25.15	24.77
		3	0	24.07	23.93	23.92	24.97	24.83	24.82
		3	2	23.93	23.86	23.96	24.83	24.76	24.86
		3	3	24.03	23.83	24.02	24.93	24.73	24.92
		6	0	23.06	22.95	22.98	23.96	23.85	23.88

	16QAM	1	0	23.39	23.01	22.93	24.29	23.91	23.83
		1	2	23.48	23.49	23.12	24.38	24.39	24.02
		1	5	23.51	22.67	23.05	24.41	23.57	23.95
Bandwidth	Modulation	RB size	RB offset	Channel/ Frequency (MHz)			Channel/ Frequency (MHz)		
				19965/ 1711.5	20175/ 1732.5	20385/ 1753.5	19965/ 1711.5	20175/ 1732.5	20385/ 1753.5
3MHz	QPSK	1	0	24.02	24.03	24.03	24.92	24.93	24.93
		1	7	24.05	24.30	24.21	24.95	25.20	25.11
		1	14	23.91	24.06	23.81	24.81	24.96	24.71
		8	0	22.88	22.94	23.03	23.78	23.84	23.93
		8	4	22.85	22.87	22.96	23.75	23.77	23.86
		8	7	22.70	22.98	22.89	23.60	23.88	23.79
	15	0	22.79	23.06	22.93	23.69	23.96	23.83	
	16QAM	1	0	22.89	22.67	23.60	23.79	23.57	24.50
		1	7	22.85	23.00	23.73	23.75	23.90	24.63
1		14	22.69	22.94	23.49	23.59	23.84	24.39	
Bandwidth	Modulation	RB size	RB offset	Channel/ Frequency (MHz)			Channel/ Frequency (MHz)		
				19975/ 1712.5	20175/ 1732.5	20375/ 1752.5	19975/ 1712.5	20175/ 1732.5	20375/ 1752.5
5MHz	QPSK	1	0	23.99	24.01	23.99	24.89	24.91	24.89
		1	13	24.03	24.26	24.18	24.93	25.16	25.08
		1	24	23.88	24.01	23.77	24.78	24.91	24.67
		12	0	22.85	22.89	22.99	23.75	23.79	23.89
		12	6	22.83	22.83	22.91	23.73	23.73	23.81
		12	13	22.68	22.96	22.85	23.58	23.86	23.75
	25	0	22.77	23.05	22.91	23.67	23.95	23.81	
	16QAM	1	0	22.86	22.63	23.57	23.76	23.53	24.47
		1	13	22.82	22.98	23.70	23.72	23.88	24.60
1		24	22.66	22.92	23.45	23.56	23.82	24.35	
Bandwidth	Modulation	RB size	RB offset	Channel/ Frequency (MHz)			Channel/ Frequency (MHz)		
				20000/ 1715	20175/ 1732.5	20350/ 1750	20000/ 1715	20175/ 1732.5	20350/ 1750
10MHz	QPSK	1	0	24.01	24.02	24.02	24.91	24.92	24.92
		1	25	24.06	24.31	24.22	24.96	25.21	25.12
		1	49	23.90	24.05	23.80	24.80	24.95	24.70
		25	0	22.88	22.94	23.03	23.78	23.84	23.93
		25	13	22.86	22.88	22.95	23.76	23.78	23.85
		25	25	22.70	23.00	22.90	23.60	23.90	23.80
	50	0	22.85	23.07	22.95	23.75	23.97	23.85	
	16QAM	1	0	22.88	22.66	23.59	23.78	23.56	24.49
		1	25	22.85	23.02	23.73	23.75	23.92	24.63
1		49	22.69	22.94	23.48	23.59	23.84	24.38	

Bandwidth	Modulation	RB size	RB offset	Channel/ Frequency (MHz)			Channel/ Frequency (MHz)		
				20025/ 1717.5	20175/ 1732.5	20325/ 1747.5	20025/ 1717.5	20175/ 1732.5	20325/ 1747.5
15MHz	QPSK	1	0	24.00	23.98	24.00	23.55	23.53	23.55
		1	38	24.04	24.30	24.19	23.59	23.85	23.74
		1	74	23.87	24.00	23.76	23.42	23.55	23.31
		36	0	22.86	22.90	23.00	22.41	22.45	22.55
		36	18	22.83	22.83	22.91	22.38	22.38	22.46
		36	39	22.67	22.97	22.86	22.22	22.52	22.41
	75	0	22.83	23.03	22.90	22.38	22.58	22.45	
	16QAM	1	0	22.83	22.64	23.57	22.38	22.19	23.12
		1	38	22.83	22.99	23.71	22.38	22.54	23.26
1		74	22.66	22.90	23.45	22.21	22.45	23.00	
Bandwidth	Modulation	RB size	RB offset	Channel/ Frequency (MHz)			Channel/ Frequency (MHz)		
				20050/ 1720	20175/ 1732.5	20300/ 1745	20050/ 1720	20175/ 1732.5	20300/ 1745
20MHz	QPSK	1	0	23.97	23.94	23.97	23.52	23.49	23.52
		1	50	24.03	24.26	24.17	23.58	23.81	23.72
		1	99	23.85	23.99	23.73	23.40	23.54	23.28
		50	0	22.83	22.85	22.96	22.38	22.40	22.51
		50	25	22.81	22.79	22.88	22.36	22.34	22.43
		50	50	22.64	22.92	22.82	22.19	22.47	22.37
	100	0	22.80	22.98	22.86	22.35	22.53	22.41	
	16QAM	1	0	22.81	22.60	23.52	22.36	22.15	23.07
		1	50	22.79	22.97	23.67	22.34	22.52	23.22
1		99	22.64	22.87	23.43	22.19	22.42	22.98	

LTE Band 12				Maximum Output Power (dBm)			ERP (dBm)		
Bandwidth	Modulation	RB size	RB offset	Channel/ Frequency (MHz)			Channel/ Frequency (MHz)		
				23017/ 699.7	23095/ 707.5	23173/ 715.3	23017/ 699.7	23095/ 707.5	23173/ 715.3
1.4MHz	QPSK	1	0	23.76	23.95	23.57	23.31	23.50	23.12
		1	2	23.67	23.83	23.68	23.22	23.38	23.23
		1	5	23.81	23.91	23.53	23.36	23.46	23.08
		3	0	23.74	23.76	23.78	23.29	23.31	23.33
		3	2	23.58	23.71	23.69	23.13	23.26	23.24
		3	3	23.69	23.81	23.64	23.24	23.36	23.19
	6	0	22.70	22.78	22.83	22.25	22.33	22.38	
	16QAM	1	0	23.53	23.16	22.71	23.08	22.71	22.26
		1	2	23.83	23.07	22.68	23.38	22.62	22.23
1		5	23.63	22.90	22.60	23.18	22.45	22.15	

Bandwidth	Modulation	RB size	RB offset	Channel/ Frequency (MHz)			Channel/ Frequency (MHz)		
				23025/ 700.5	23095/ 707.5	23165/ 714.5	23025/ 700.5	23095/ 707.5	23165/ 714.5
3MHz	QPSK	1	0	23.92	23.75	23.64	23.47	23.30	23.19
		1	7	24.23	23.94	23.82	23.78	23.49	23.37
		1	14	23.51	23.73	23.65	23.06	23.28	23.20
		8	0	22.86	22.98	22.87	22.41	22.53	22.42
		8	4	22.99	23.03	22.68	22.54	22.58	22.23
		8	7	22.85	22.89	22.97	22.40	22.44	22.52
	16QAM	15	0	22.85	22.93	22.99	22.40	22.48	22.54
		1	0	22.59	23.27	22.84	22.14	22.82	22.39
		1	7	22.55	23.73	23.28	22.10	23.28	22.83
		1	14	22.58	23.36	22.68	22.13	22.91	22.23
Bandwidth	Modulation	RB size	RB offset	Channel/ Frequency (MHz)			Channel/ Frequency (MHz)		
				23035/ 701.5	23095/ 707.5	23155/ 713.5	23035/ 701.5	23095/ 707.5	23155/ 713.5
5MHz	QPSK	1	0	23.91	23.71	23.62	23.46	23.26	23.17
		1	13	24.21	23.93	23.79	23.76	23.48	23.34
		1	24	23.48	23.68	23.61	23.03	23.23	23.16
		12	0	22.84	22.94	22.84	22.39	22.49	22.39
		12	6	22.96	22.98	22.64	22.51	22.53	22.19
		12	13	22.82	22.86	22.93	22.37	22.41	22.48
	16QAM	25	0	22.83	22.89	22.94	22.38	22.44	22.49
		1	0	22.54	23.25	22.82	22.09	22.80	22.37
		1	13	22.53	23.70	23.26	22.08	23.25	22.81
		1	24	22.55	23.32	22.65	22.10	22.87	22.20
Bandwidth	Modulation	RB size	RB offset	Channel/ Frequency (MHz)			Channel/ Frequency (MHz)		
				23060/ 704	23095/ 707.5	23130/ 711	23060/ 704	23095/ 707.5	23130/ 711
10MHz	QPSK	1	0	23.88	23.67	23.59	23.43	23.22	23.14
		1	25	24.20	23.89	23.77	23.75	23.44	23.32
		1	49	23.46	23.67	23.58	23.01	23.22	23.13
		25	0	22.81	22.89	22.80	22.36	22.44	22.35
		25	13	22.94	22.94	22.61	22.49	22.49	22.16
		25	25	22.79	22.81	22.89	22.34	22.36	22.44
	16QAM	50	0	22.80	22.84	22.90	22.35	22.39	22.45
		1	0	22.52	23.21	22.77	22.07	22.76	22.32
		1	25	22.49	23.68	23.22	22.04	23.23	22.77
		1	49	22.53	23.29	22.63	22.08	22.84	22.18

LTE Band 13				Maximum Output Power (dBm)			ERP (dBm)		
Bandwidth	Modulation	RB size	RB offset	Channel/ Frequency (MHz)			Channel/ Frequency (MHz)		
				23205/779.5	23230/782	23255/784.5	23205/779.5	23230/782	23255/784.5
5MHz	QPSK	1	0	23.73	23.60	23.61	23.28	23.15	23.16
		1	13	23.64	23.75	23.95	23.19	23.30	23.50
		1	24	23.58	23.74	23.82	23.13	23.29	23.37
		12	0	22.81	22.69	22.81	22.36	22.24	22.36
		12	6	22.65	22.71	22.83	22.20	22.26	22.38
		12	13	22.74	22.76	22.96	22.29	22.31	22.51
	16QAM	25	0	22.76	22.78	22.89	22.31	22.33	22.44
		1	0	22.88	22.86	22.46	22.43	22.41	22.01
		1	13	22.49	22.81	22.64	22.04	22.36	22.19
		1	24	23.12	22.65	22.56	22.67	22.20	22.11
Bandwidth	Modulation	RB size	RB offset	Channel/ Frequency (MHz)			Channel/ Frequency (MHz)		
				23230/ 782			23230/ 782		
10MHz	QPSK	1	0	23.61			23.16		
		1	25	23.77			23.32		
		1	49	23.73			23.28		
		25	0	22.71			22.26		
		25	13	22.73			22.28		
		25	25	22.82			22.37		
	16QAM	50	0	22.74			22.29		
		1	0	22.98			22.53		
		1	25	23.23			22.78		
		1	49	23.01			22.56		

6.2 Radiated Spurious Emission

Sweep the whole frequency band through the range from 9kHz to the 10th harmonic of the carrier, the emissions below the noise floor will not be recorded in the report.

WCDMA Band IV CH-Middle

Harmonic	Frequency (MHz)	SG (dBm)	Cable Loss (dB)	Gain (dBi)	Antenna Polarization	EIRP Level (dBm)	Limit (dBm)	Margin (dB)	Azimuth (deg)
2	3465.20	-64.83	2.70	12.70	Horizontal	-54.83	-13.00	41.83	225
3	5197.80	-49.50	3.20	12.50	Horizontal	-40.20	-13.00	27.20	31
4	6930.40	-73.08	4.20	11.80	Horizontal	-65.48	-13.00	52.48	1
5	8663.00	-65.30	4.40	12.50	Horizontal	-57.20	-13.00	44.20	134
6	10395.60	-62.90	4.70	11.30	Horizontal	-56.30	-13.00	43.30	225
7	12128.20	-64.28	5.20	13.80	Horizontal	-55.68	-13.00	42.68	66
8	13860.80	-60.01	5.70	11.30	Horizontal	-54.41	-13.00	41.41	47
9	15593.40	-69.97	6.10	16.80	Horizontal	-59.27	-13.00	46.27	310
10	17326.00	-63.36	6.10	14.20	Horizontal	-55.26	-13.00	42.26	28

Note: 1.The other Spurious RF Radiated emissions level is no more than noise floor.
2. The worst emission was found in the antenna is Horizontal position.

LTE Band 4 QPSK 1.4MHz CH-Middle, RB 1

Harmonic	Frequency (MHz)	SG (dBm)	Cable Loss (dB)	Gain (dBi)	Antenna Polarization	EIRP Level (dBm)	Limit (dBm)	Margin (dB)	Azimuth (deg)
2	3464.25	-48.78	2.70	12.70	Vertical	-38.78	-13.00	25.78	31
3	5197.50	-35.01	3.20	12.50	Vertical	-25.71	-13.00	12.71	18
4	6930.00	-58.65	4.20	11.80	Vertical	-51.05	-13.00	38.05	225
5	8662.50	-52.73	4.40	12.50	Vertical	-44.63	-13.00	31.63	56
6	10395.00	-52.39	4.70	11.30	Vertical	-45.79	-13.00	32.79	47
7	12127.50	-56.57	5.20	13.80	Vertical	-47.97	-13.00	34.97	315
8	13860.00	-48.93	5.70	11.30	Vertical	-43.33	-13.00	30.33	33
9	15592.50	-58.28	6.10	16.80	Vertical	-47.58	-13.00	34.58	90
10	17325.00	-52.73	6.10	14.20	Vertical	-44.63	-13.00	31.63	18

Note: 1.The other Spurious RF Radiated emissions level is no more than noise floor.
2. The worst emission was found in the antenna is Vertical position.

LTE Band 4 QPSK 5MHz CH-Middle, RB 1

Harmonic	Frequency (MHz)	SG (dBm)	Cable Loss (dB)	Gain (dBi)	Antenna Polarization	EIRP Level (dBm)	Limit (dBm)	Margin (dB)	Azimuth (deg)
2	3460.50	-48.09	2.70	12.70	Vertical	-38.09	-13.00	25.09	13
3	5191.50	-35.71	3.20	12.50	Vertical	-26.41	-13.00	13.41	279
4	6930.00	-59.74	4.20	11.80	Vertical	-52.14	-13.00	39.14	14
5	8662.50	-53.33	4.40	12.50	Vertical	-45.23	-13.00	32.23	79
6	10395.00	-51.47	4.70	11.30	Vertical	-44.87	-13.00	31.87	246
7	12127.50	-55.41	5.20	13.80	Vertical	-46.81	-13.00	33.81	33
8	13860.00	-49.62	5.70	11.30	Vertical	-44.02	-13.00	31.02	0
9	15592.50	-59.05	6.10	16.80	Vertical	-48.35	-13.00	35.35	9
10	17325.00	-53.21	6.10	14.20	Vertical	-45.11	-13.00	32.11	135

Note: 1.The other Spurious RF Radiated emissions level is no more than noise floor.
2. The worst emission was found in the antenna is Vertical position.

LTE Band 4 QPSK 20MHz CH-Middle, RB 1

Harmonic	Frequency (MHz)	SG (dBm)	Cable Loss (dB)	Gain (dBi)	Antenna Polarization	EIRP Level (dBm)	Limit (dBm)	Margin (dB)	Azimuth (deg)
2	3447.75	-50.37	2.70	12.70	Vertical	-40.37	-13.00	27.37	18
3	5170.88	-37.34	3.20	12.50	Vertical	-28.04	-13.00	15.04	231
4	6930.00	-59.25	4.20	11.80	Vertical	-51.65	-13.00	38.65	93
5	8662.50	-56.64	4.40	12.50	Vertical	-48.54	-13.00	35.54	56
6	10395.00	-51.29	4.70	11.30	Vertical	-44.69	-13.00	31.69	147
7	12127.50	-56.56	5.20	13.80	Vertical	-47.96	-13.00	34.96	225
8	13860.00	-50.15	5.70	11.30	Vertical	-44.55	-13.00	31.55	3
9	15592.50	-59.23	6.10	16.80	Vertical	-48.53	-13.00	35.53	90
10	17325.00	-53.64	6.10	14.20	Vertical	-45.54	-13.00	32.54	14

Note: 1.The other Spurious RF Radiated emissions level is no more than noise floor.
2. The worst emission was found in the antenna is Vertical position.

LTE Band 12 QPSK 1.4MHz CH-Middle, RB 1

Harmonic	Frequency (MHz)	SG (dBm)	Cable Loss (dB)	Gain (dBi)	Antenna Polarization	ERP Level (dBm)	Limit (dBm)	Margin (dB)	Azimuth (deg)
2	1415.00	-61.77	1.70	8.70	Vertical	-56.92	-13.00	43.92	13
3	2122.50	-32.22	2.10	11.10	Vertical	-25.37	-13.00	12.37	86
4	2830.00	-59.85	2.30	13.10	Vertical	-51.20	-13.00	38.20	276
5	3537.50	-51.27	2.60	12.70	Vertical	-43.32	-13.00	30.32	46
6	4245.00	-63.09	3.30	12.50	Vertical	-56.04	-13.00	43.04	25
7	4952.50	-58.43	3.40	12.50	Vertical	-51.48	-13.00	38.48	314
8	5660.00	-61.45	3.30	12.50	Vertical	-54.40	-13.00	41.40	90
9	6367.50	-59.06	3.80	11.50	Vertical	-53.51	-13.00	40.51	27
10	7075.00	-58.11	4.20	11.80	Vertical	-52.66	-13.00	39.66	135

Note: 1. The other Spurious RF Radiated emissions level is no more than noise floor.
 2. The worst emission was found in the antenna is Vertical position.

LTE Band 12 QPSK 5MHz CH-Middle, RB 1

Harmonic	Frequency (MHz)	SG (dBm)	Cable Loss (dB)	Gain (dBi)	Antenna Polarization	ERP Level (dBm)	Limit (dBm)	Margin (dB)	Azimuth (deg)
2	1410.60	-59.41	1.70	8.70	Vertical	-54.56	-13.00	41.56	286
3	2115.90	-33.51	2.10	11.10	Vertical	-26.66	-13.00	13.66	93
4	2821.20	-58.77	2.30	13.10	Vertical	-50.12	-13.00	37.12	286
5	3512.50	-53.41	2.60	12.70	Vertical	-45.46	-13.00	32.46	258
6	4215.00	-63.62	3.30	12.50	Vertical	-56.57	-13.00	43.57	44
7	4917.50	-61.20	3.40	12.50	Vertical	-54.25	-13.00	41.25	314
8	5620.00	-61.38	3.30	12.50	Vertical	-54.33	-13.00	41.33	90
9	6322.50	-59.05	3.80	11.50	Vertical	-53.50	-13.00	40.50	26
10	7025.00	-57.81	4.20	11.80	Vertical	-52.36	-13.00	39.36	186

Note: 1. The other Spurious RF Radiated emissions level is no more than noise floor.
 2. The worst emission was found in the antenna is Vertical position.

LTE Band 12 QPSK 10MHz CH-Middle, RB 1

Harmonic	Frequency (MHz)	SG (dBm)	Cable Loss (dB)	Gain (dBi)	Antenna Polarization	ERP Level (dBm)	Limit (dBm)	Margin (dB)	Azimuth (deg)
2	1406.40	-56.64	1.70	8.70	Vertical	-51.79	-13.00	38.79	106
3	2109.60	-35.83	2.10	11.10	Vertical	-28.98	-13.00	15.98	75
4	2812.80	-60.48	2.30	13.10	Vertical	-51.83	-13.00	38.83	108
5	3537.50	-54.59	2.60	12.70	Vertical	-46.64	-13.00	33.64	93
6	4245.00	-63.02	3.30	12.50	Vertical	-55.97	-13.00	42.97	76
7	4952.50	-60.02	3.40	12.50	Vertical	-53.07	-13.00	40.07	4
8	5660.00	-61.66	3.30	12.50	Vertical	-54.61	-13.00	41.61	225
9	6367.50	-58.28	3.80	11.50	Vertical	-52.73	-13.00	39.73	90
10	7075.00	-58.28	4.20	11.80	Vertical	-52.83	-13.00	39.83	16

Note: 1.The other Spurious RF Radiated emissions level is no more than noise floor.
2. The worst emission was found in the antenna is Vertical position.

LTE Band 13 QPSK 5MHz CH-Middle, RB 1

Harmonic	Frequency (MHz)	SG (dBm)	Cable Loss (dB)	Gain (dBi)	Antenna Polarization	EIRP Level (dBm)	Limit (dBm)	Margin (dB)	Azimuth (deg)
2	1559.00	-60.59	1.70	8.70	Vertical	-53.59	-40.00	13.59	48
Harmonic	Frequency (MHz)	SG (dBm)	Cable Loss (dB)	Gain (dBi)	Antenna Polarization	ERP Level (dBm)	Limit (dBm)	Margin (dB)	Azimuth (deg)
3	2339.58	-33.38	2.10	12.00	Vertical	-25.63	-13.00	12.63	101
4	3118.00	-56.07	2.30	13.10	Vertical	-47.42	-13.00	34.42	0
5	3897.50	-48.82	2.90	12.50	Vertical	-41.37	-13.00	28.37	279
6	4677.00	-61.15	3.10	12.50	Vertical	-53.90	-13.00	40.90	31
7	5456.50	-50.19	3.30	12.50	Vertical	-43.14	-13.00	30.14	167
8	6236.00	-61.04	3.50	12.80	Vertical	-53.89	-13.00	40.89	22
9	7015.50	-59.09	4.20	11.80	Vertical	-53.64	-13.00	40.64	264
10	7795.00	-56.95	4.40	12.30	Vertical	-51.20	-13.00	38.20	18

Note: 1.The other Spurious RF Radiated emissions level is no more than noise floor.
2. The worst emission was found in the antenna is Vertical position.

LTE Band 13 QPSK 10MHz CH-Middle, RB 1

Harmonic	Frequency (MHz)	SG (dBm)	Cable Loss (dB)	Gain (dBi)	Antenna Polarization	ERP Level (dBm)	Limit (dBm)	Margin (dB)	Azimuth (deg)
2	1555.37	-54.81	1.70	8.70	Vertical	-49.96	-13.00	36.96	48
3	2332.80	-34.00	2.10	12.00	Vertical	-26.25	-13.00	13.25	89
4	3108.00	-56.08	2.30	13.10	Vertical	-47.43	-13.00	34.43	13
5	3885.00	-49.48	2.90	12.50	Vertical	-42.03	-13.00	29.03	247
6	4662.00	-61.10	3.10	12.50	Vertical	-53.85	-13.00	40.85	97
7	5439.00	-51.96	3.30	12.50	Vertical	-44.91	-13.00	31.91	22
8	6216.00	-60.51	3.50	12.80	Vertical	-53.36	-13.00	40.36	28
9	6993.00	-58.50	4.20	11.80	Vertical	-53.05	-13.00	40.05	60
10	7770.00	-57.68	4.40	12.30	Vertical	-51.93	-13.00	38.93	135

Note: 1. The other Spurious RF Radiated emissions level is no more than noise floor.
 2. The worst emission was found in the antenna is Vertical position.

7 Main Test Instruments

Name	Manufacturer	Type	Serial Number	Calibration Date	Expiration Date
Wideband radio communication tester	R&S	CMW500	113645	2023-03-16	2024-03-15
Spectrum Analyzer	R&S	FSV30	104028	2023-05-12	2024-05-11
Loop Antenna	SCHWARZBECK	FMZB1519	1519-047	2023-04-16	2026-04-15
TRILOG Broadband Antenna	Schwarzbeck	VULB 9163	01439	2021-06-30	2024-06-29
Horn Antenna	Schwarzbeck	BBHA 9120D	1594	2020-12-17	2023-12-16
Horn Antenna	ETS-Lindgren	3160-09	00102643	2021-10-10	2024-10-09
Software	R&S	EMC32	10.35.10	/	/

ANNEX A: The EUT Appearance

The EUT Appearance are submitted separately.

ANNEX B: Test Setup Photos

The Test Setup Photos are submitted separately.

***** END OF REPORT *****