



RF TEST REPORT

Applicant ID TECH
FCC ID WQJ-IDCL-51
Brand ID TECH
Product AC100
Model IDCL-51
Report No. RXA1604-0066RF02R1
Issue Date June 13, 2016

TA Technology (Shanghai) Co., Ltd. tested the above equipment in accordance with the requirements in **FCC CFR47 Part 15C (2015)**. The test results show that the equipment tested is capable of demonstrating compliance with the requirements as documented in this report.

Handwritten signature of Lingling Kang in blue ink.

Performed by: Lingling Kang

Handwritten signature of Kai Xu in blue ink.

Approved by: Kai Xu



TA Technology (Shanghai) Co., Ltd.

No.145, Jintang Rd, Tangzhen Industry Park, Pudong Shanghai, China

TEL: +86-021-50791141/2/3

FAX: +86-021-50791141/2/3-8000



TABLE OF CONTENT

1. Test Laboratory	4
1.1. Notes of the test report.....	4
1.2. Test facility	4
1.3. Testing Location.....	5
2. General Description of Equipment under Test.....	6
3. Test Information	7
4. Test Configuration	8
5. Test Case Results	9
5.1. Peak Power Output –Conducted	9
5.2. 6dB Occupied Bandwidth.....	11
5.3. Band Edge Compliance.....	15
5.4. Power Spectral Density	17
5.5. Spurious Radiated Emissions in the Restricted Band	26
5.6. Spurious RF Conducted Emissions.....	21
5.7. Radiates Emission	26
5.8. Conducted Emission	69
6. Main Test Instruments.....	76
ANNEX A: EUT Appearance and Test Setup	77
A.1 EUT Appearance	77
A.2 Test Setup	78



Summary of measurement results

Number	Summary of measurements of results	Clause in FCC rules	Verdict
1	Maximum peak conducted output power	15.247(b)(3)	PASS
2	6 dB bandwidth	15.247(a)(2)	PASS
3	Maximum power spectral density	15.247(e)	PASS
4	Band Edge	15.247(d)	PASS
5	Spurious RF Conducted Emissions	15.247(d)	PASS
6	Radiated Emissions in restricted frequency bands	15.247(d),15.205,15.209	PASS
7	Radiated Emissions	15.247(d),15.205,15.209	PASS
8	Conducted Emissions	15.207	PASS
Date of Testing: April 22, 2016 ~ May 6, 2016			



1. Test Laboratory

1.1. Notes of the test report

This report shall not be reproduced in full or partial, without the written approval of TA technology (shanghai) co., Ltd).The results documented in this report apply only to the tested sample, under the conditions and modes of operation as described herein .Measurement Uncertainties were not taken into account and are published for informational purposes only. This report is written to support regulatory compliance of the applicable standards stated above. This report must not be used by the client to claim product certification, approval, or endorsement by CNAS or any government agencies.

1.2. Test facility

CNAS (accreditation number:L2264)

TA Technology (Shanghai) Co., Ltd. has obtained the accreditation of China National Accreditation Service for Conformity Assessment (CNAS).

FCC (recognition number is 428261)

TA Technology (Shanghai) Co., Ltd. has been listed on the US Federal Communications Commission list of test facilities recognized to perform electromagnetic emissions measurements.

IC (recognition number is 8510A)

TA Technology (Shanghai) Co., Ltd. has been listed by industry Canada to perform electromagnetic emission measurement.

VCCI (recognition number is C-4595, T-2154, R-4113, G-766)

TA Technology (Shanghai) Co., Ltd. has been listed by industry Japan to perform electromagnetic emission measurement.

A2LA(Certificate Number: 3857.01)

TA Technology (Shanghai) Co., Ltd. has been listed by American Association for Laboratory Accreditation to perform electromagnetic emission measurement.



1.3. Testing Location

Company: TA Technology (Shanghai) Co., Ltd.
Address: No.145, Jintang Rd, Tangzhen Industry Park, Pudong
City: Shanghai
Post code: 201201
Country: P. R. China
Contact: Xu Kai
Telephone: +86-021-50791141/2/3
Fax: +86-021-50791141/2/3-8000
Website: <http://www.ta-shanghai.com>
E-mail: xukai@ta-shanghai.com

2. General Description of Equipment under Test

Client Information

Applicant	ID TECH
Applicant address	10721 Walker Street Cypress, CA 90630
Manufacturer	ID TECH
Manufacturer address	10721 Walker Street Cypress, CA 90630

General information

EUT Description	
Model:	IDCL-51
SN:	617T000007
Hardware Version:	80144301
Software Version:	ID TECH AC100 V1.00
Power Supply:	AC adapter
Antenna Type:	Internal Antenna
Test Mode:	802.11b 802.11g, 802.11n(HT20);
Modulation Type:	802.11b: DSSS; 802.11g/n(HT20): OFDM
Max. Conducted Power	Wi-Fi 2.4G: 17.25dBm
Operating Frequency Range(s)	2400 ~ 2483.5 MHz
EUT Accessory	
Adapter	Manufacture:BSY Model : BSYH050200UU Input: 100-240Vac 50/60Hz 0.4A Output: 5.0Vdc 2.0A
Note: The information of the EUT is declared by the manufacturer. Please refer to the specifications or user manual for details.	



3. Applied Standards

According to the specifications of the manufacturer, it must comply with the requirements of the following standards:

FCC CFR47 Part 15C (2015) Radio Frequency Devices

ANSI C63.10 (2013)

KDB 558074 D01 DTS Meas Guidance v03r05

4. Test Configuration

Test Mode

The EUT was programmed to be in continuously transmitting mode and the transmit duty cycle is not less than 98%.

The EUT has been associated with peripherals and configuration operated in a manner tended to maximize its emission characteristics in a typical application.

The radiated emission was measured in the following position: EUT stand-up position (Z axis), lie-down position (X, Y axis). The worst emission was found in stand-up position (Z axis) and the worst case was recorded.

In order to find the worst case condition, Pre-tests are needed at the presence of different data rate. Preliminary tests have been done on all the configuration for confirming worst case. Data rate below means worst-case rate of each test item.

Worst-case data rates are shown as following table.

Band	Data Rate
802.11b	11 Mbps
802.11g	6 Mbps
802.11n HT20	MCS0

5. Test Case Results

5.1. Peak Power Output –Conducted

Ambient condition

Temperature	Relative humidity	Pressure
23°C ~25°C	45%~50%	101.5kPa

Methods of Measurement

During the process of the testing, The EUT was connected to peak power meter with a known loss. The EUT is max power transmission with proper modulation. The peak detector is used. We use Maximum Peak Conducted Output Power Level Method in KDB 558074 D01 for this test.

Test Setup

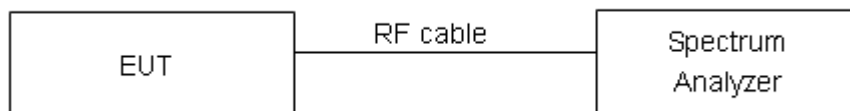

Limits

Rule Part 15.247 (b) (3) specifies that " For systems using digital modulation in the 902–928 MHz, 2400–2483.5 MHz: 1 Watt."

Peak Output Power	$\leq 1W$ (30dBm)
-------------------	-------------------

Measurement Uncertainty

The assessed measurement uncertainty to ensure 95% confidence level for the normal distribution is with the coverage factor $k = 2$, $U = 0.44$ dB.

**Test Results**

Network Standards	Carrier frequency (MHz)	Peak Output Power (dBm)	Limit (dBm)	Conclusion
802.11b	2412	17.17	30	PASS
	2437	17.25	30	PASS
	2462	17.07	30	PASS
802.11g	2412	16.64	30	PASS
	2437	16.67	30	PASS
	2462	16.70	30	PASS
802.11n HT20	2412	15.60	30	PASS
	2437	15.65	30	PASS
	2462	15.68	30	PASS

5.2. 6dB Bandwidth

Ambient condition

Temperature	Relative humidity	Pressure
23°C ~25°C	45%~50%	101.5kPa

Method of Measurement

The EUT was connected to the spectrum analyzer through an external attenuator (20dB) and a known loss cable. RBW is set to 100 kHz; VBW is set to 300 kHz on spectrum analyzer.

Test Setup

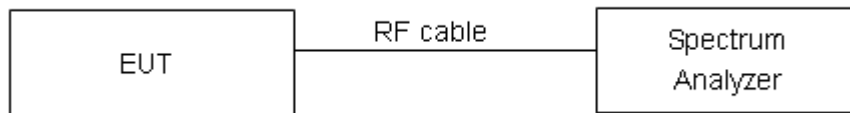

Limits

Rule Part 15.247 (a) (2) specifies that “Systems using digital modulation techniques may operate in the 902–928 MHz, 2400–2483.5 MHz bands. The minimum 6 dB bandwidth shall be at least 500 kHz.”

minimum 6 dB bandwidth	≥ 500 kHz
------------------------	-----------

Measurement Uncertainty

The assessed measurement uncertainty to ensure 95% confidence level for the normal distribution is with the coverage factor $k = 2$, $U = 936$ Hz.

**Test Results:**

Network Standards	Carrier frequency (MHz)	Minimum 6 dB bandwidth (MHz)	Limit(kHz)	Conclusion
802.11b	2412	6.969	500	PASS
	2437	7.816	500	PASS
	2462	7.706	500	PASS
802.11g	2412	15.070	500	PASS
	2437	15.119	500	PASS
	2462	15.083	500	PASS
802.11n HT20	2412	17.286	500	PASS
	2437	17.210	500	PASS
	2462	17.367	500	PASS



802.11b, Carrier frequency (MHz): 2412

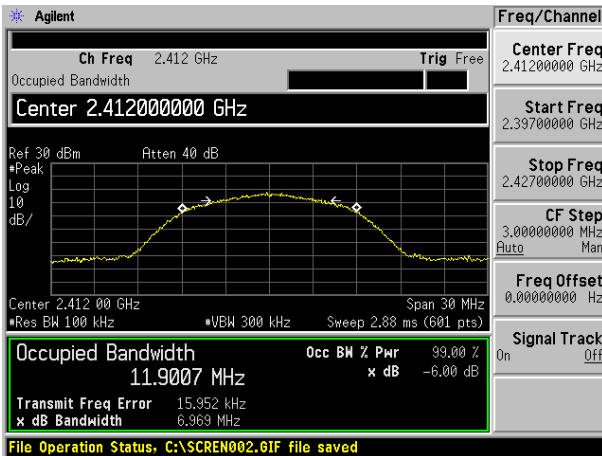

802.11g, Carrier frequency (MHz): 2412

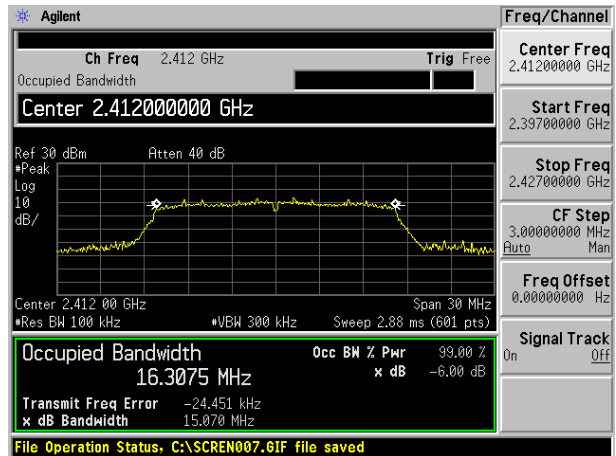

802.11b, Carrier frequency (MHz): 2437

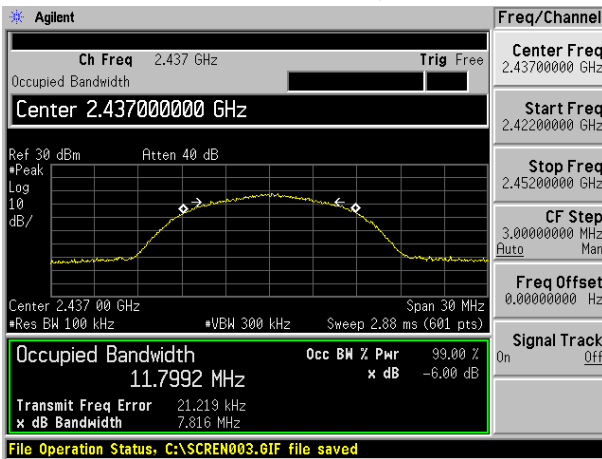

802.11g, Carrier frequency (MHz): 2437

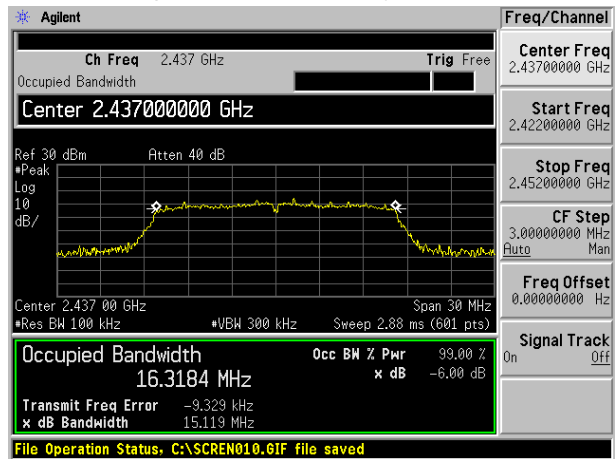

802.11b, Carrier frequency (MHz): 2462

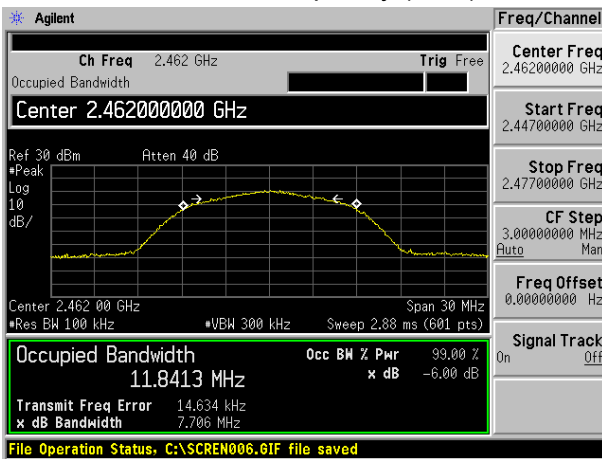

802.11g, Carrier frequency (MHz): 2462

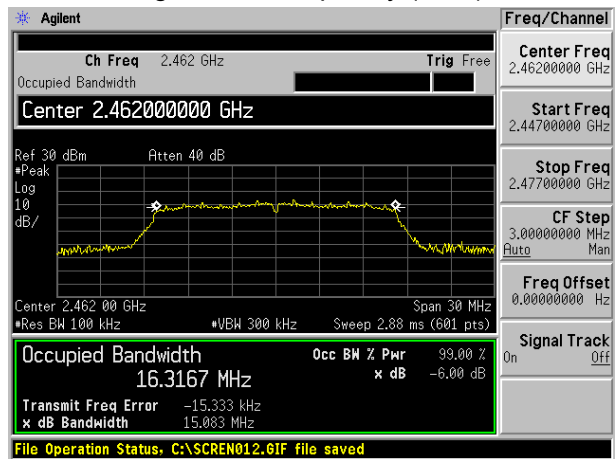



802.11n(HT20), Carrier frequency (MHz): 2412

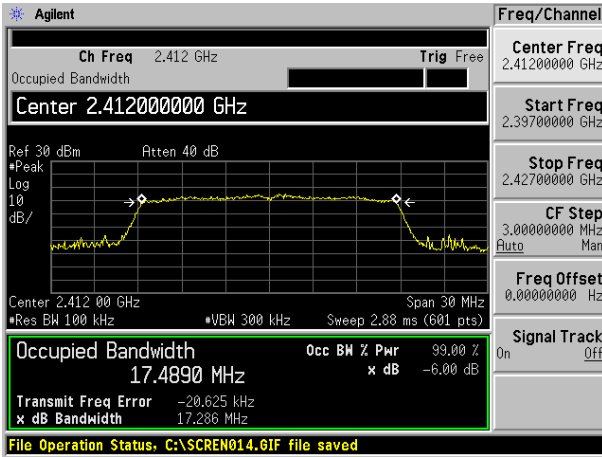

802.11n(HT20), Carrier frequency (MHz): 2437

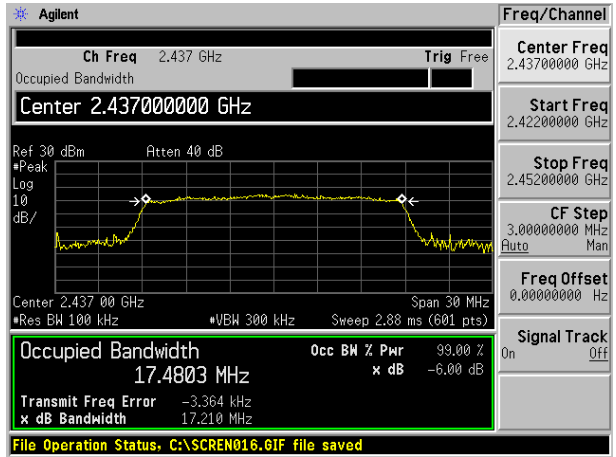

802.11n(HT20), Carrier frequency (MHz):2462

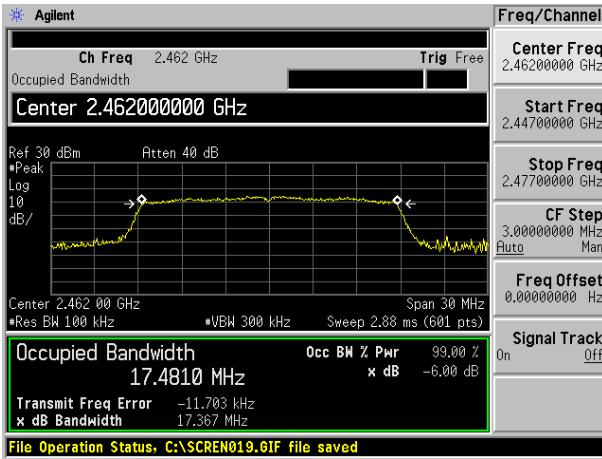

5.3. Band Edge

Ambient condition

Temperature	Relative humidity	Pressure
23°C ~25°C	45%~50%	101.5kPa

Method of Measurement

The EUT was connected to the spectrum analyzer through an external attenuator (20dB) and a known loss cable the band edge of the lowest and highest channels were measured. The peak detector is used and RBW is set to 100 kHz and VBW is set to 300 kHz on spectrum analyzer. Spectrum analyzer plots are included on the following pages.

Test Setup

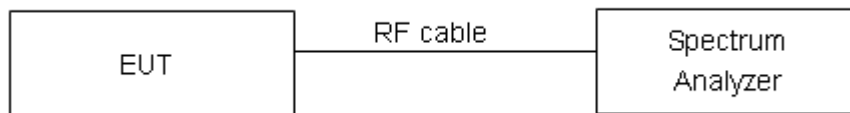

Limits

Rule Part 15.247(d) specifies that “In any 100 kHz bandwidth outside the frequency band in which the spread spectrum or digitally modulated intentional radiator is operating, the radio frequency power that is produced by the intentional radiator shall be at least 20 dB below that in the 100 kHz bandwidth within the band that contains the highest level of the desired power, based on either an RF conducted or a radiated measurement, provided the transmitter demonstrates compliance with the peak conducted power limits.”

Measurement Uncertainty

The assessed measurement uncertainty to ensure 95% confidence level for the normal distribution is with the coverage factor $k = 1.96$.

Frequency	Uncertainty
2GHz-3GHz	1.407 dB



Test Results: PASS

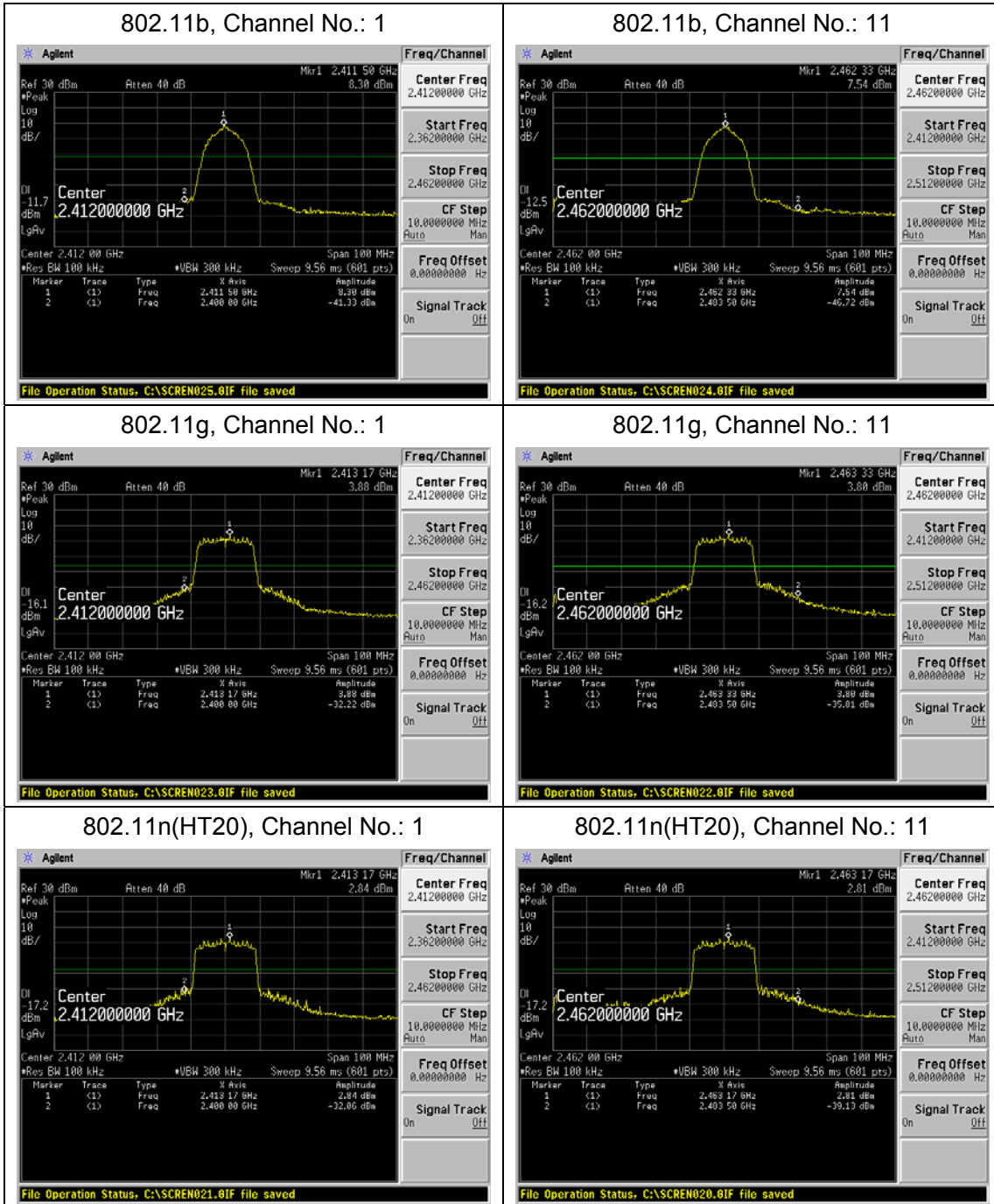

5.4. Power Spectral Density

Ambient condition

Temperature	Relative humidity	Pressure
23°C ~25°C	45%~50%	101.5kPa

Method of Measurement

The EUT was connected to the spectrum analyzer through an external attenuator (20dB) and a known loss cable.

RBW is set to 3 kHz and VBW is set to 10 kHz for Wi-Fi 2.4G on spectrum analyzer.

Set the span to 1.5 times the DTS channel bandwidth. Sweep time = auto couple. Trace mode = max hold. The peak power spectral density is recorded.

Test setup

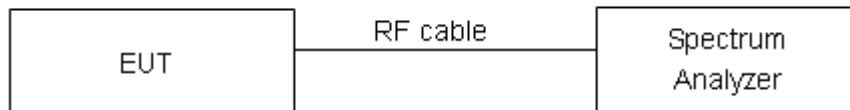

Limits

Rule Part 15.247(e) specifies that” For digitally modulated systems, the power spectral density conducted from the intentional radiator to the antenna shall not be greater than 8 dBm in any 3 kHz band during any time interval of continuous transmission. ”

Limits	≤ 8 dBm / 3kHz
--------	----------------

Measurement Uncertainty

The assessed measurement uncertainty to ensure 95% confidence level for the normal distribution is with the coverage factor $k = 2$, $U = 0.75\text{dB}$.

**Test Results:**

Network Standards	Channel Number	Power Spectral Density (dBm / 3kHz)	Limit (dBm / 3kHz)	Conclusion
802.11b	1	-7.92	8	PASS
	6	7.72	8	PASS
	11	-7.34	8	PASS
802.11g	1	-10.95	8	PASS
	6	-10.86	8	PASS
	11	-10.06	8	PASS
802.11n HT20	1	-11.33	8	PASS
	6	-12.16	8	PASS
	11	-11.67	8	PASS

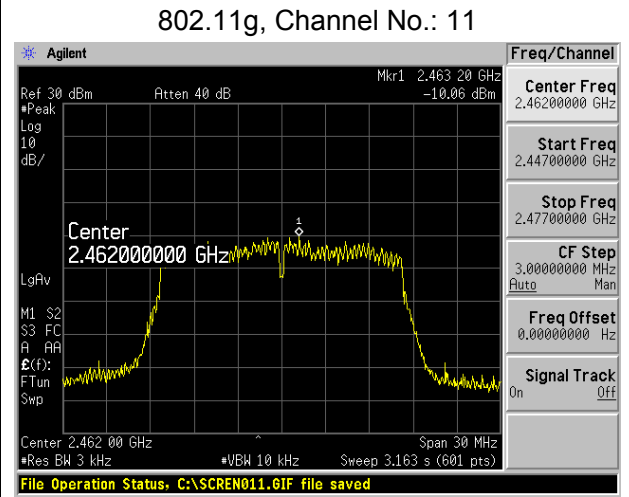
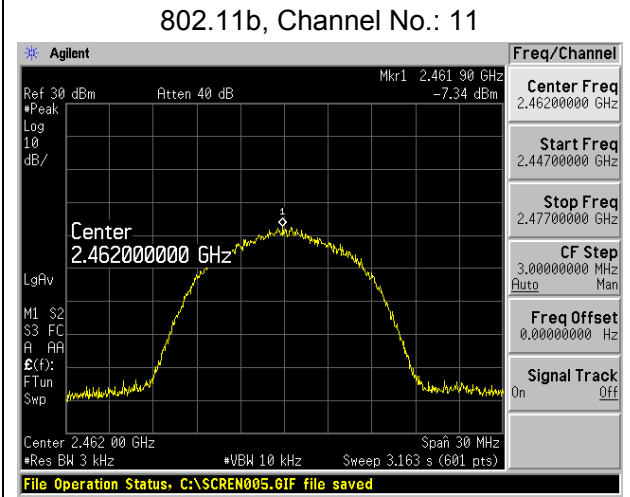
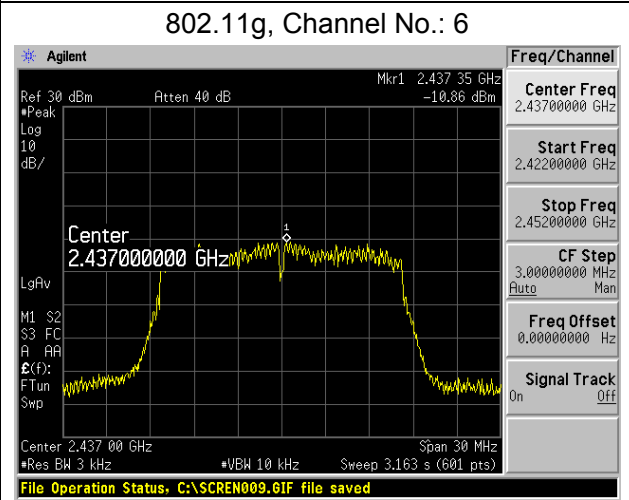
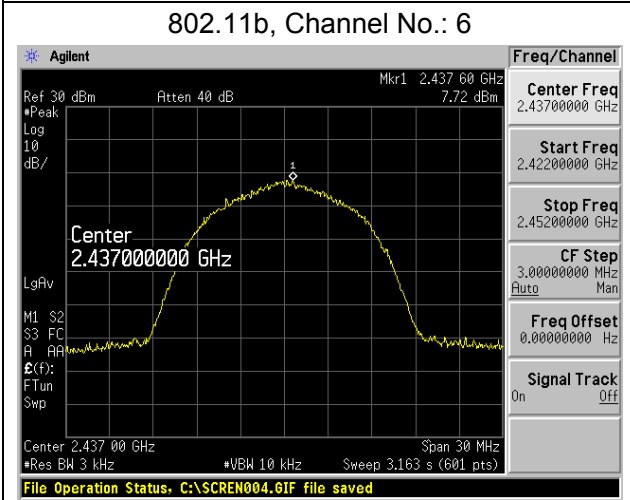
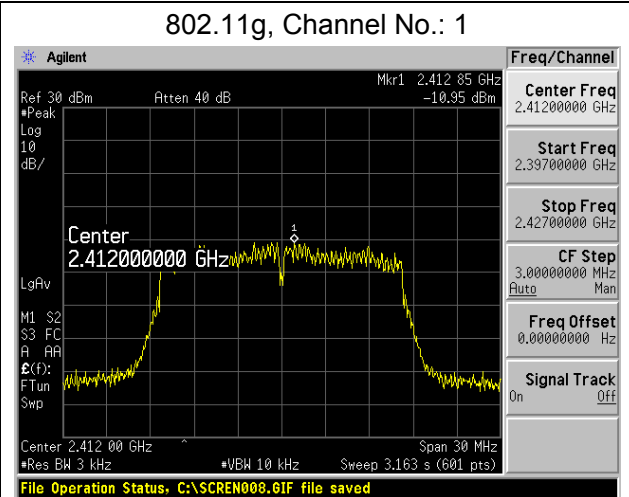
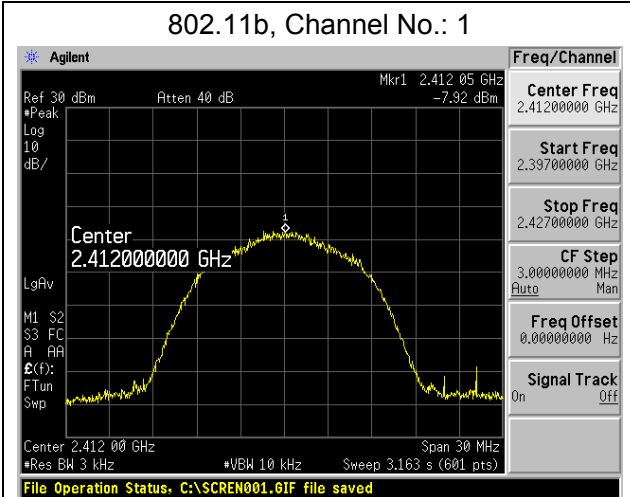



802.11n(HT20), Channel No. 1

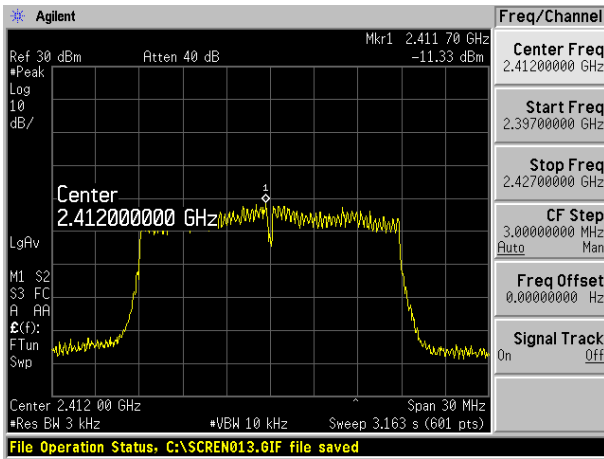

802.11n(HT20), Channel No. 6

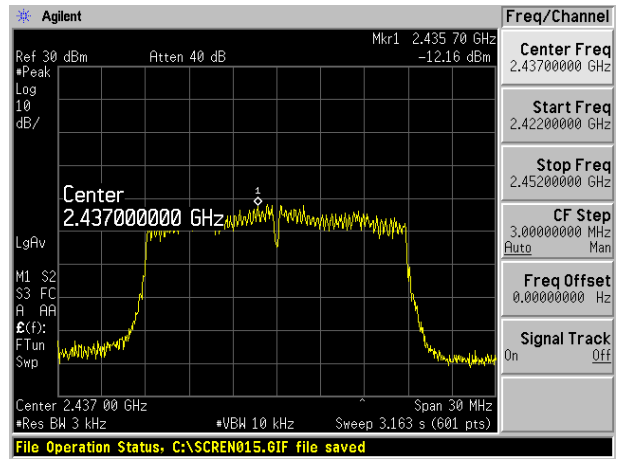

802.11n(HT20), Channel No. 11

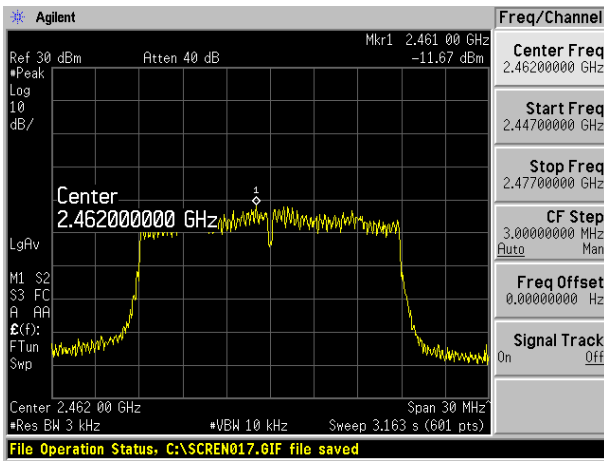

5.5. Spurious RF Conducted Emissions

Ambient condition

Temperature	Relative humidity	Pressure
23°C ~25°C	45%~50%	101.5kPa

Method of Measurement

The EUT was connected to the spectrum analyzer with a known loss. The spectrum analyzer scans from 30MHz to the 10th harmonic of the carrier. The peak detector is used. RBW and VBW are set to 100 kHz, Sweep is set to ATUO.

The test is in transmitting mode.

Test setup

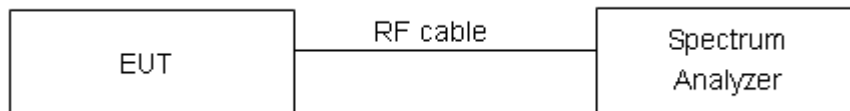

Limits

Rule Part 15.247(d) pacifies that “In any 100 kHz bandwidth outside the frequency band in which the spread spectrum intentional radiator is operating, the radio frequency power that is produced by the intentional radiator shall be at least 20 dB below that in the 100 kHz bandwidth within the band that contains the highest level of the desired power.”

Network Standards	Carrier frequency (MHz)	Reference value (dBm)	Limit
802.11b	2412	0.77	-19.23
	2437	2.52	-17.48
	2462	1.13	-18.87
802.11g	2412	0.09	-19.91
	2437	0.43	-19.57
	2462	-0.08	-20.08
802.11n HT20	2412	-1.21	-21.21
	2437	-0.83	-20.83
	2462	-1.57	-21.57



Measurement Uncertainty

The assessed measurement uncertainty to ensure 95% confidence level for the normal distribution is with the coverage factor $k = 1.96$.

Frequency	Uncertainty
100kHz-2GHz	0.684 dB
2GHz-26GHz	1.407 dB



Test Results:

If disturbances were found more than 20dB below limit line, the mark is not required for the EUT.
The signal beyond the limit is carrier.

802.11b CH1 30MHz to 18GHz

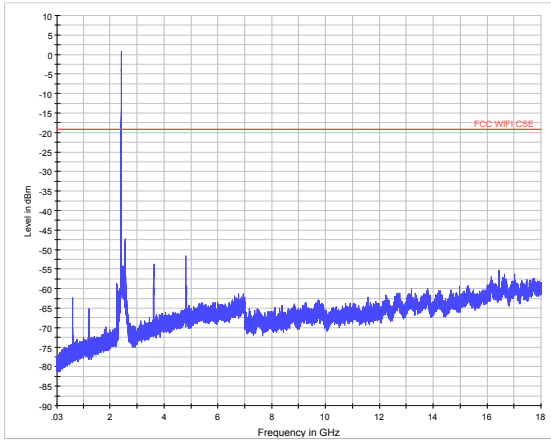

802.11b CH1 18GHz to 26.5GHz

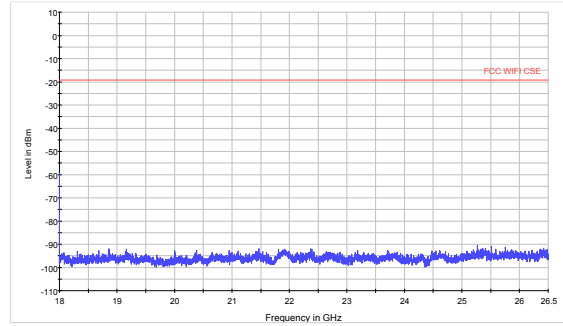

802.11b CH6 30MHz to 18GHz

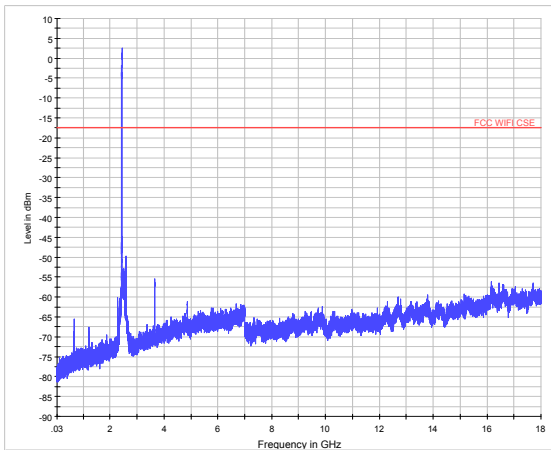

802.11b CH6 18GHz to 26.5GHz

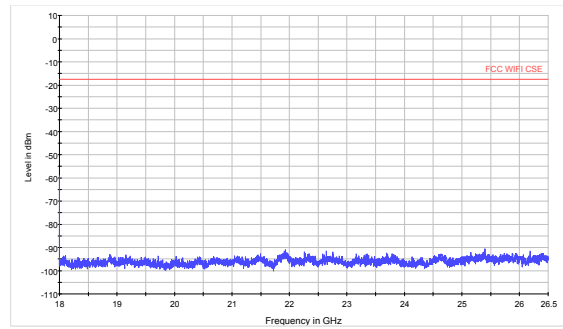

802.11b CH11 30MHz to 18GHz

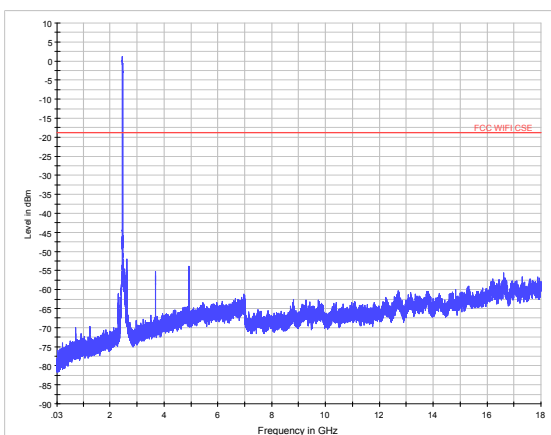

802.11b CH11 18GHz to 26.5GHz

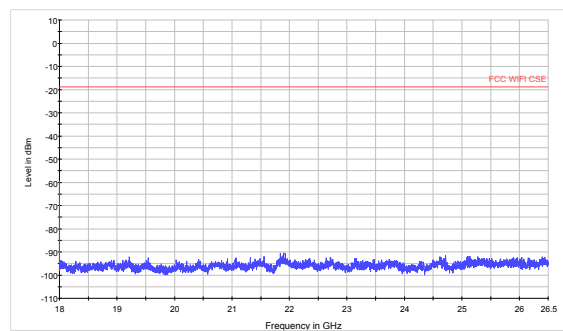



802.11g CH1 30MHz to 18GHz

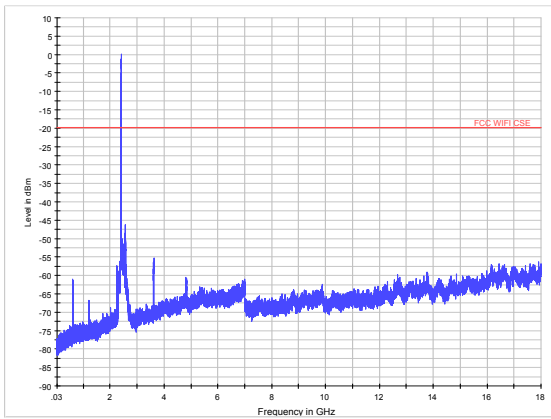

802.11g CH1 18GHz to 26.5GHz

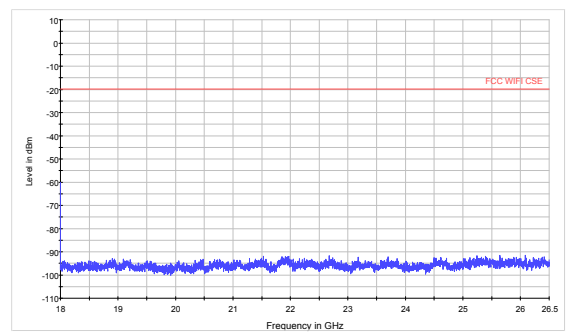

802.11g CH6 30MHz to 18GHz

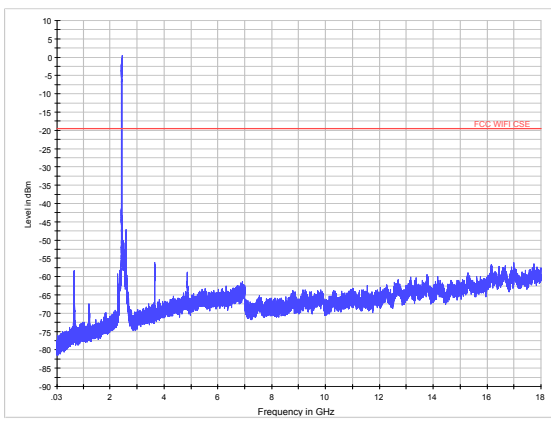

802.11g CH6 18GHz to 26.5GHz

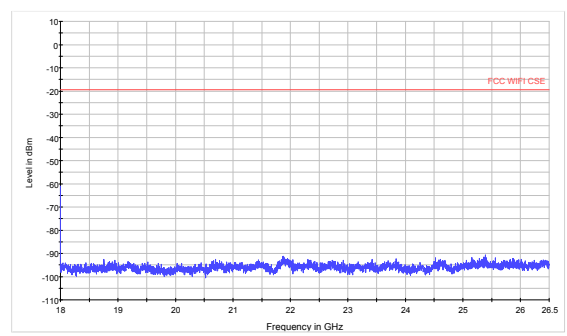

802.11g CH11 30MHz to 18GHz

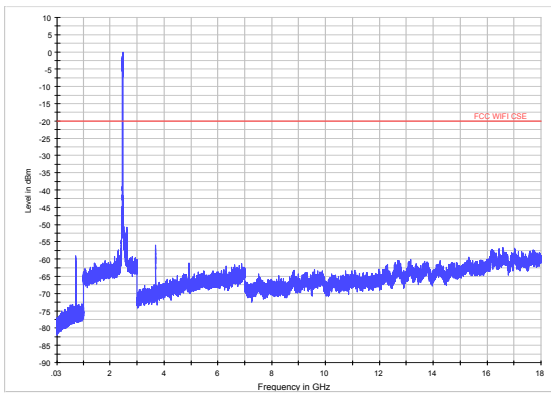

802.11g CH11 18GHz to 26.5GHz

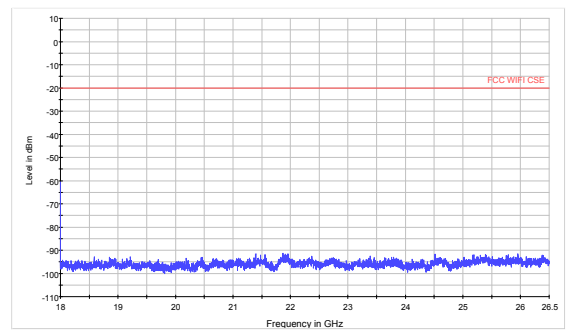



802.11n (HT20) CH1 30MHz to 18GHz

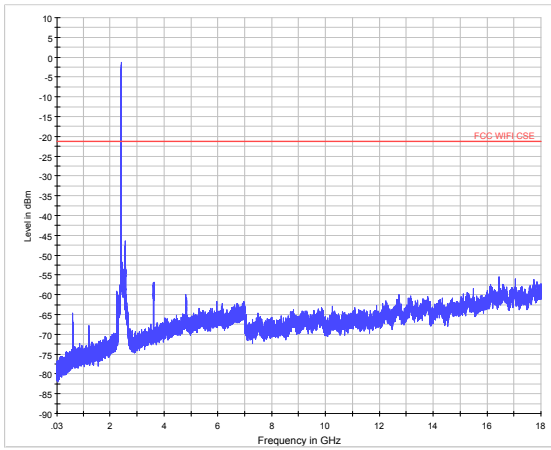

802.11n (HT20) CH1 18GHz to 26.5GHz

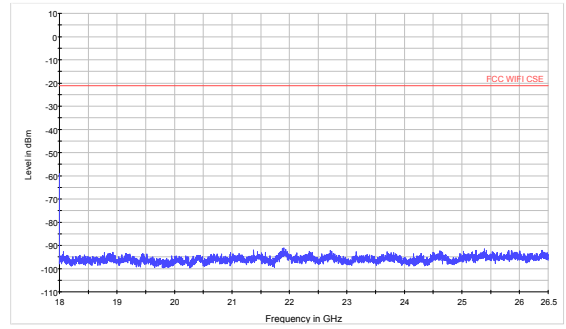

802.11n (HT20) CH6 30MHz to 18GHz

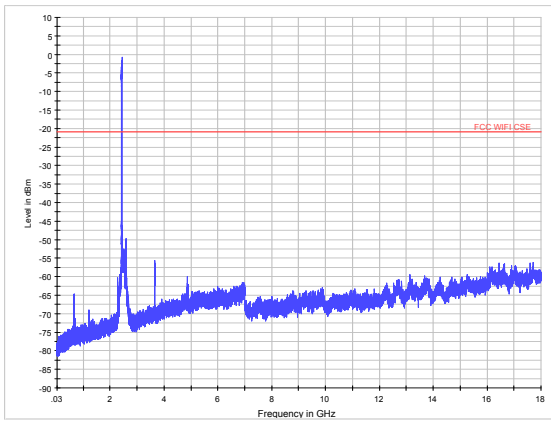

802.11n (HT20) CH6 18GHz to 26.5GHz

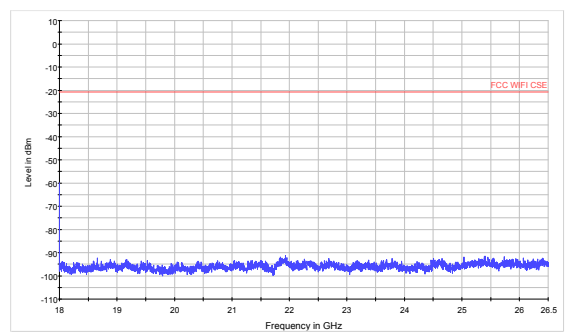

802.11n (HT20) CH11 30MHz to 18GHz

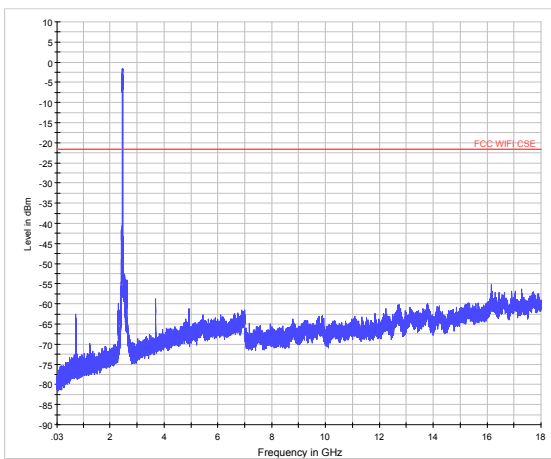

802.11n (HT20) CH11 18GHz to 26.5GHz

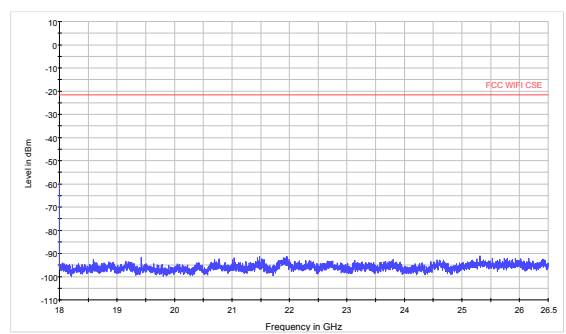

5.6. Radiated Emissions in the Restricted Band

Ambient condition

Temperature	Relative humidity	Pressure
23°C ~25°C	45%~50%	101.5kPa

Method of Measurement

The Equipment Under Test (EUT) was set up on a non-conductive table in the semi-anechoic chamber. The test was performed at the distance of 3 m between the EUT and the receiving antenna. The turntable shall be rotated from 0 to 360 degrees for detecting the maximum of radiated spurious signal level. The measurements shall be repeated with orthogonal polarization of the test antenna. RBW is set to 100kHz. The data of cable loss and antenna factor has been calibrated in full testing frequency range before the testing. Sweep the whole frequency band through the range from 9kHz to the 10th harmonic of the carrier, and the emissions less than 20 dB below the permissible value are reported.

Set the spectrum analyzer in the following:

- (a) PEAK: RBW=VBW=1MHz / Sweep=AUTO
- (b) AVERAGE: RBW=1MHz / VBW=1MHz / Sweep=AUTO

This setting method can refer to **KDB 558074**.

The field strength of spurious emission was measured in the following position: EUT stand-up position (Z axis), lie-down position (X, Y axis). The worst emission was found in stand-up position (Y axis) and the antenna is vertical.

The test is in transmitting mode.

Test setup

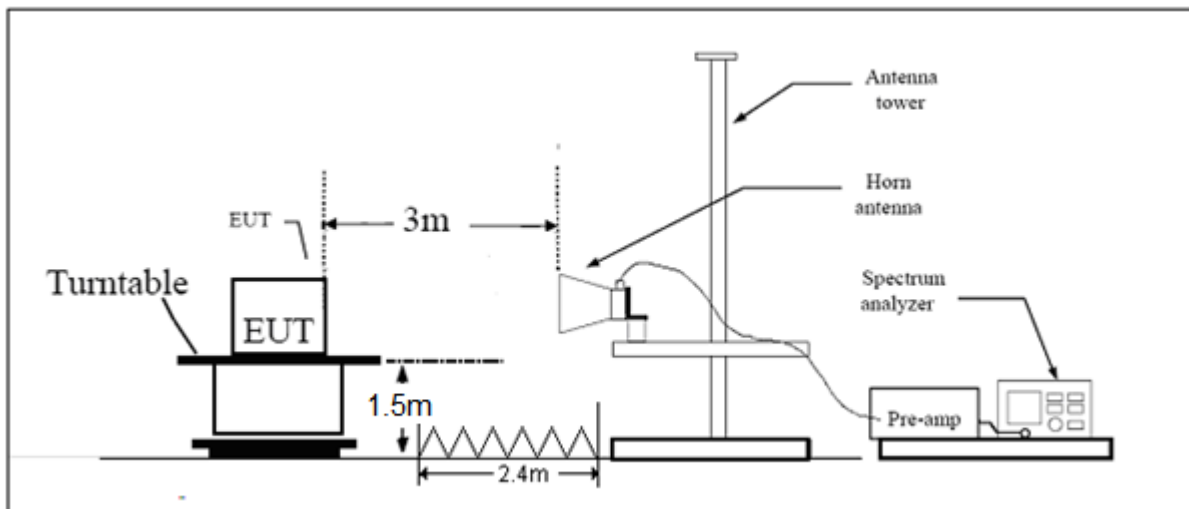

Note: Area side: 2.4mX3.6m

Limits

Spurious Radiated Emissions are permitted in any of the frequency bands listed below:

MHz	MHz	MHz	GHz
0.090 - 0.110	16.42 - 16.423	399.9 - 410	4.5 - 5.15
¹ 0.495 - 0.505	16.69475 - 16.69525	608 - 614	5.35 - 5.46
2.1735 - 2.1905	16.80425 - 16.80475	960 - 1240	7.25 - 7.75
4.125 - 4.128	25.5 - 25.67	1300 - 1427	8.025 - 8.5
4.17725 - 4.17775	37.5 - 38.25	1435 - 1626.5	9.0 - 9.2
4.20725 - 4.20775	73 - 74.6	1645.5 - 1646.5	9.3 - 9.5
6.215 - 6.218	74.8 - 75.2	1660 - 1710	10.6 - 12.7
6.26775 - 6.26825	108 - 121.94	1718.8 - 1722.2	13.25 - 13.4
6.31175 - 6.31225	123 - 138	2200 - 2300	14.47 - 14.5
8.291 - 8.294	149.9 - 150.05	2310 - 2390	15.35 - 16.2
8.362 - 8.366	156.52475 - 156.52525	2483.5 - 2500	17.7 - 21.4
8.37625 - 8.38675	156.7 - 156.9	2690 - 2900	22.01 - 23.12
8.41425 - 8.41475	162.0125 - 167.17	3260 - 3267	23.6 - 24.0
12.29 - 12.293	167.72 - 173.2	3332 - 3339	31.2 - 31.8
12.51975 - 12.52025	240 - 285	3345.8 - 3358	36.43 - 36.5
12.57675 - 12.57725	322 - 335.4	3600 - 4400	(²)
13.36 - 13.41			

Limit in restricted band

Frequency of emission (MHz)	Field strength(uV/m)	Field strength(dBuV/m)
30-88	100	40
88-216	150	43.5
216-960	200	46
Above960	500	54

§15.35(b)

There is also a limit on the radio frequency emissions, as measured using instrumentation with a peak detector function, corresponding to 20 dB above the maximum permitted average limit.

Peak Limit=74 dBuV/m

Average Limit=54 dBuV/m

Measurement Uncertainty

The assessed measurement uncertainty to ensure 95% confidence level for the normal distribution is with the coverage factor $k = 1.96$, $U = 3.55$ dB.



Test Results:

PASS

The signal beyond the limit is carrier.

802.11b-Channel 1: Peak

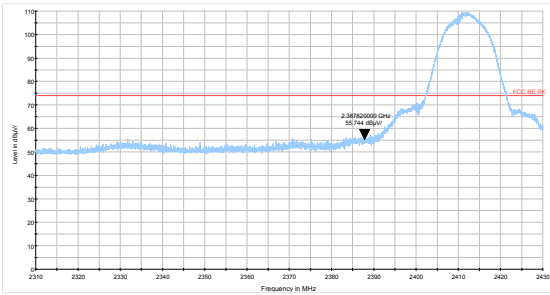

802.11b-Channel 1: Average

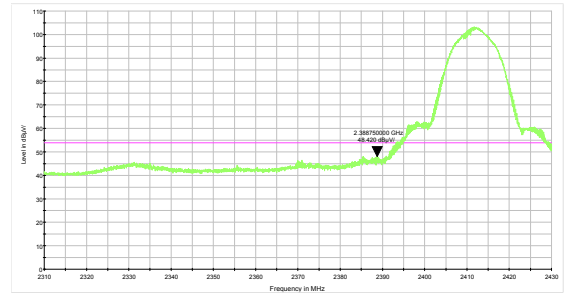

802.11b-Channel 11: Peak

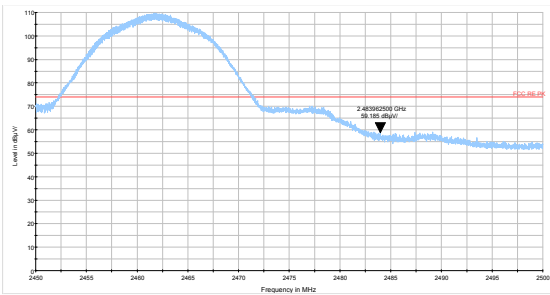

802.11b-Channel 11: Average

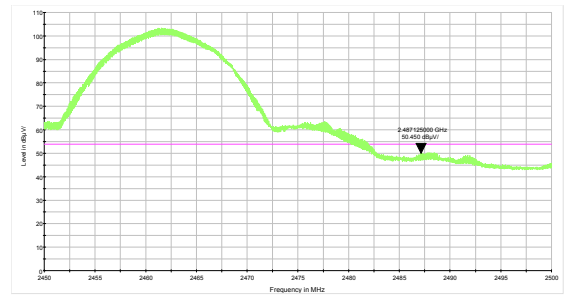

802.11g-Channel 1: Peak

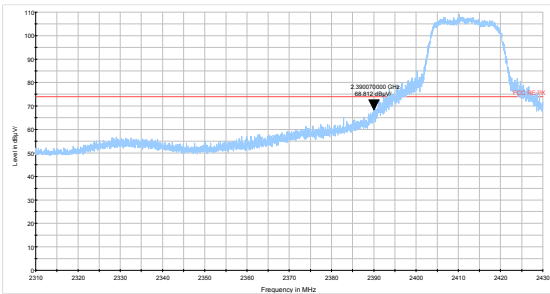

802.11g-Channel 1: Average

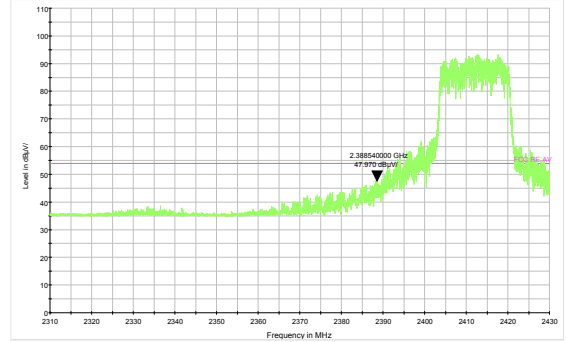

802.11g-Channel 11: Peak

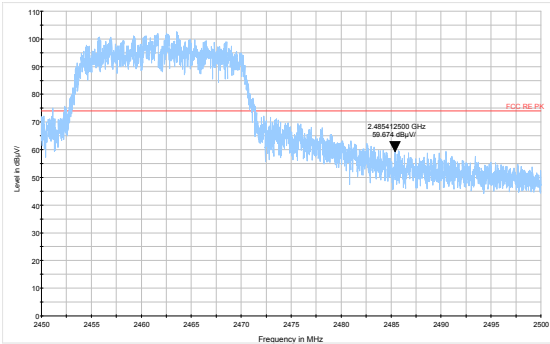

802.11g-Channel 11: Average

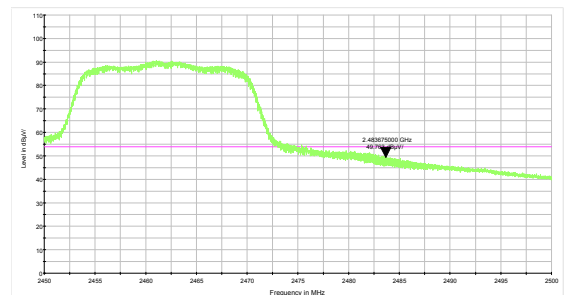



802.11n HT20 -Channel 1: Peak

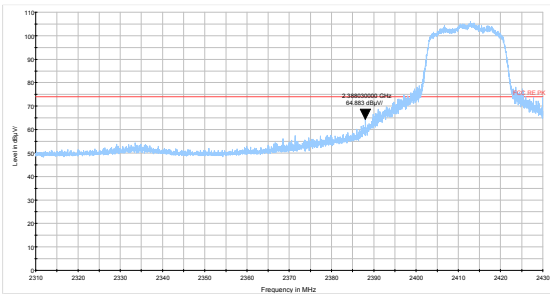

802.11n HT20-Channel 1: Average

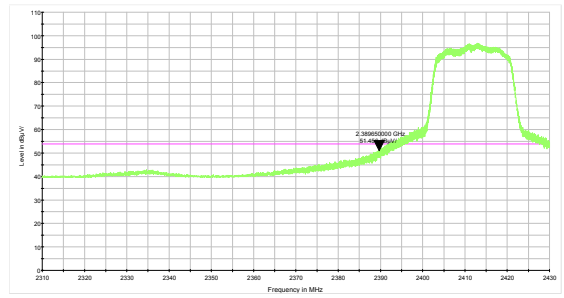

802.11n HT20-Channel 11: Peak

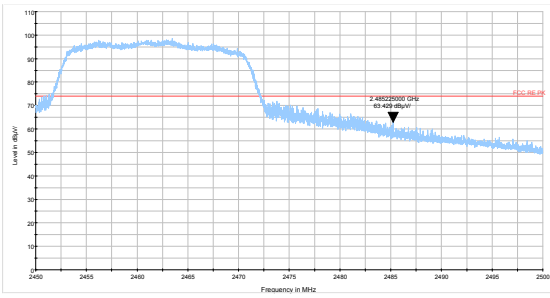

802.11n HT20-Channel 11: Average

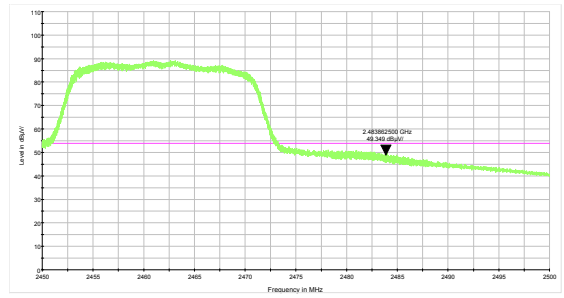

5.7. Radiates Emission

Ambient condition

Temperature	Relative humidity	Pressure
23°C ~25°C	45%~50%	102.5kPa

Method of Measurement

The test set-up was made in accordance to the general provisions of ANSI C63.10-2013. The Equipment Under Test (EUT) was set up on a non-conductive table in the semi-anechoic chamber. The test was performed at the distance of 3 m between the EUT and the receiving antenna. The radiated emissions measurements were made in a typical installation configuration.

Sweep the whole frequency band through the range from 9 kHz to the 10th harmonic of the carrier, and the emissions less than 20 dB below the permissible value are reported.

During the test, below 30MHz, the center of the loop shall be 1 meters; above 30MHz, the height of receive antenna shall be moved from 1 to 4 meters, and the antenna shall be performed under horizontal and vertical polarization. The turntable shall be rotated from 0 to 360 degrees for detecting the maximum of radiated spurious signal level. The measurements shall be repeated with orthogonal polarization of the test antenna. The data of cable loss and antenna factor has been calibrated in full testing frequency range before the testing.

Set the spectrum analyzer in the following:

Below 1GHz (detector: Peak and Quasi-Peak)

RBW=100 kHz / VBW=300 kHz / Sweep=AUTO

Above 1GHz (detector: Peak):

(a) PEAK: RBW=1MHz VBW=3MHz/ Sweep=AUTO

(b) AVERAGE: RBW=1MHz / VBW=3MHz / Sweep=AUTO

The radiated emission was measured in the following position: EUT stand-up position (Z axis), lie-down position (X, Y axis). The worst emission was found in stand-up position (Z axis) and the worst case was recorded.

The test is in transmitting mode.

Test setup

9KHz~~~ 30MHz

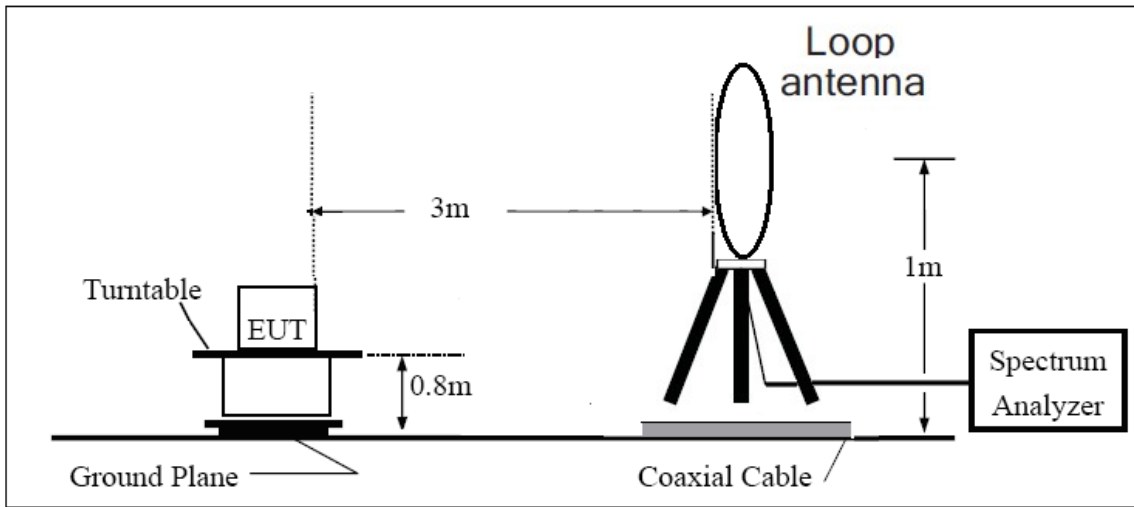

30MHz~~~ 1GHz

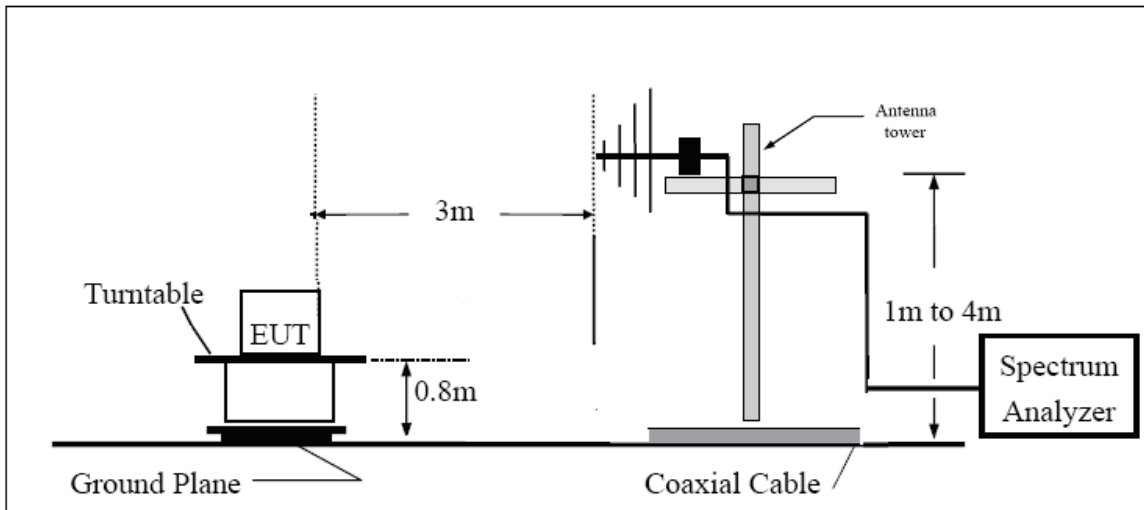

Above 1GHz

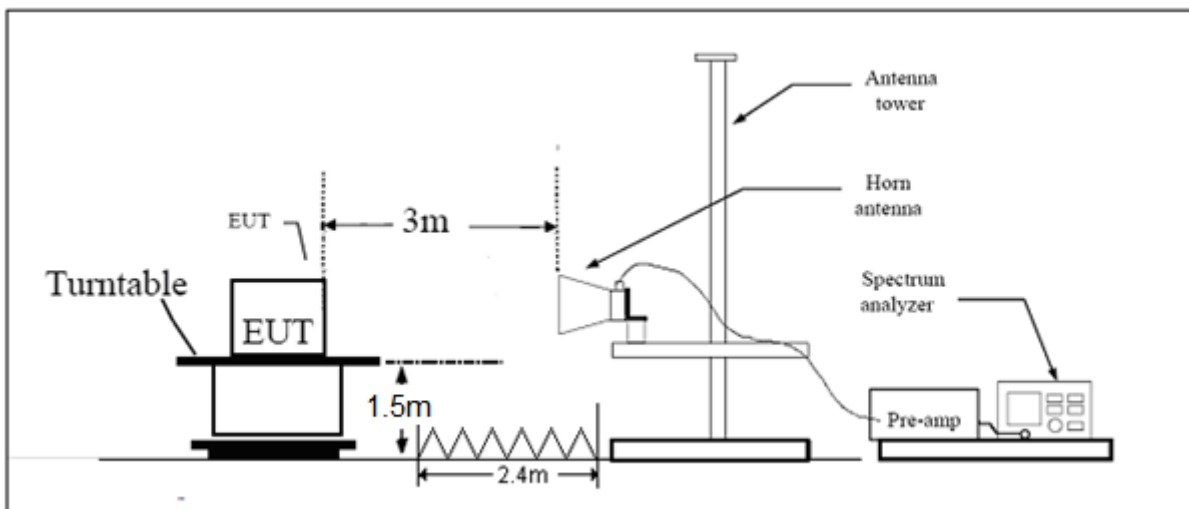

Note: Area side:2.4mX3.6m

**Limits**

Rule Part 15.247(d) specifies that “In addition, radiated emissions which fall in the restricted bands, as defined in § 15.205(a), must also comply with the radiated emission limits specified in § 15.209(a) (see § 15.205(c)).”

Limit in restricted band

Frequency of emission (MHz)	Field strength(uV/m)	Field strength(dBuV/m)
0.009–0.490	2400/F(kHz)	/
0.490–1.705	24000/F(kHz)	/
1.705–30.0	30	/
30-88	100	40
88-216	150	43.5
216-960	200	46
Above960	500	54

§15.35(b)

There is also a limit on the radio frequency emissions, as measured using instrumentation with a peak detector function, corresponding to 20 dB above the maximum permitted average limit.

Measurement Uncertainty

The assessed measurement uncertainty to ensure 95% confidence level for the normal distribution is with the coverage factor $k = 1.96$.

Frequency	Uncertainty
9KHz-30MHz	3.55 dB
30MHz-200MHz	4.19 dB
200MHz-1GHz	3.63 dB
Above 1GHz	3.68 dB

Test result

Sweep from 9 kHz to 30MHz, and the emissions more than 20 dB below the permissible value are not reported.

The following graphs display the maximum values of horizontal and vertical by software.
For above 1GHz, Blue trace uses the peak detection, Green trace uses the average detection.

802.11b CH1

FCC RE 0.03-1GHz QP Class C

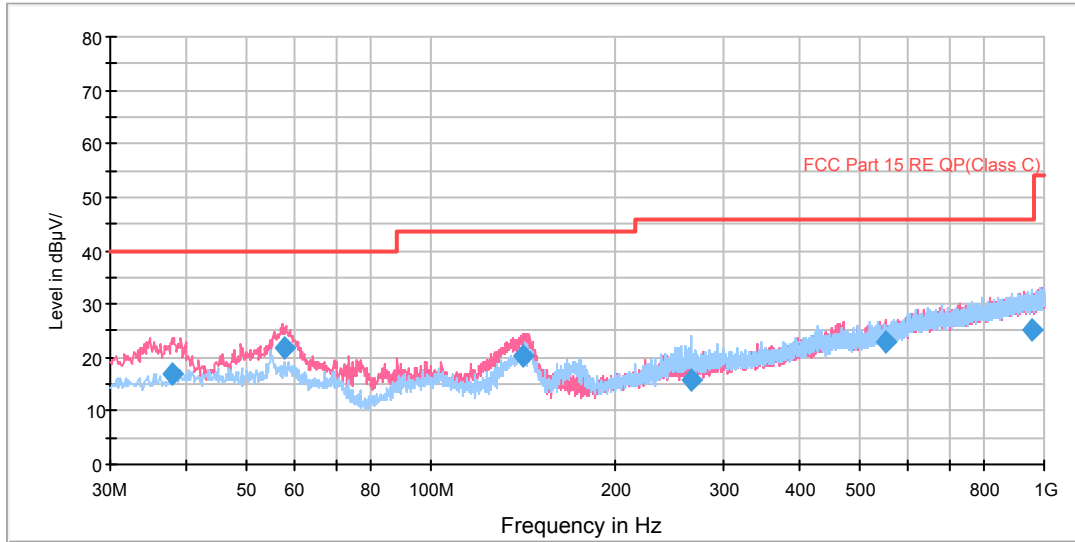

Radiates Emission from 30MHz to 1GHz

Frequency (MHz)	Quasi-Peak (dBuV/m)	Height (cm)	Polarization	Azimuth (deg)	Reading value (dBuV/m)	Correct Factor (dB)	Margin (dB)	Limit (dBuV/m)
37.922500	17.0	100.0	V	294.0	29.6	12.6	23.0	40.0
57.681250	22.0	125.0	V	207.0	34.6	12.6	18.0	40.0
141.827500	20.4	114.0	V	289.0	29.3	8.9	23.1	43.5
265.877500	15.6	100.0	H	336.0	30.1	14.5	30.4	46.0
550.001250	22.9	100.0	V	0.0	43.9	21.0	23.1	46.0
955.253750	25.1	100.0	H	0.0	51.2	26.1	20.9	46.0

- Remark: 1. Quasi-Peak = Reading value + Correction factor
- 2. Correction Factor = Antenna factor+ Insertion loss(cable loss+amplifier gain)
- 3. Margin = Limit – Quasi-Peak

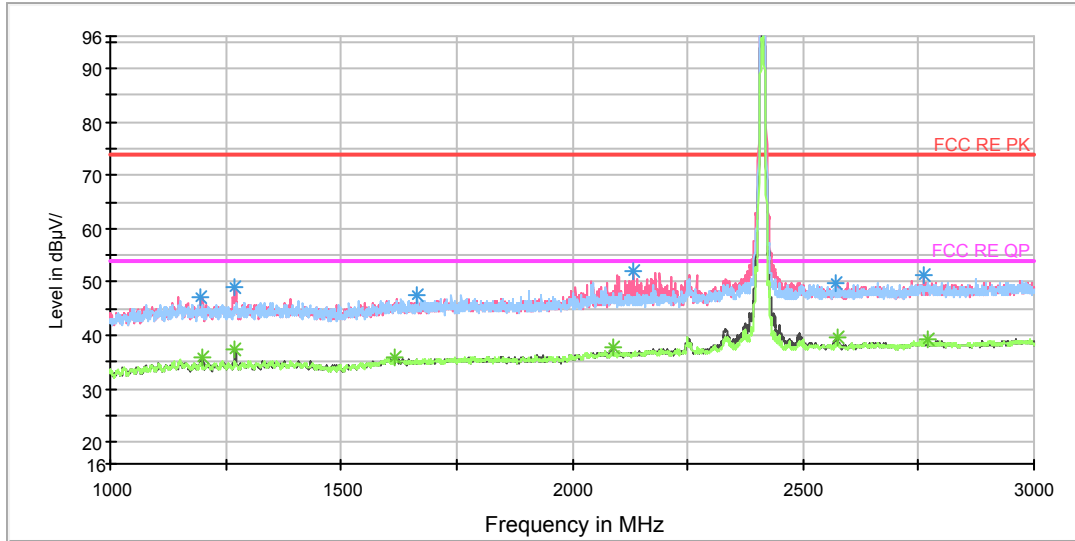

Note: The signal beyond the limit is carrier.

Radiates Emission from 1GHz to 3GHz

Frequency (MHz)	Peak (dBuV/m)	Height (cm)	Polarization	Azimuth (deg)	Reading value (dBuV/m)	Correct Factor (dB)	Margin (dB)	Limit (dBuV/m)
1196.500000	47.3	100.0	V	354.0	48.0	-0.7	26.7	74
1267.500000	48.9	100.0	V	0.0	49.2	-0.3	25.1	74
1665.500000	47.4	100.0	H	132.0	48.6	1.2	26.6	74
2134.000000	52.1	100.0	V	354.0	55.2	3.1	21.9	74
2571.500000	50.0	100.0	V	0.0	55.3	5.3	24.0	74
2762.000000	51.4	100.0	V	359.0	57.1	5.7	22.6	74

Remark: 1. Correction Factor = Antenna factor+ Insertion loss (cable loss + amplifier gain)

Frequency (MHz)	Average (dBuV/m)	Height (cm)	Polarization	Azimuth (deg)	Reading value (dBuV/m)	Correct Factor (dB)	Margin (dB)	Limit (dBuV/m)
1200.000000	35.9	100.0	V	354.0	36.6	-0.7	18.1	54
1270.500000	37.3	100.0	V	0.0	37.6	-0.3	16.7	54
1615.500000	35.7	100.0	V	358.0	36.8	1.1	18.3	54
2090.000000	37.6	100.0	V	339.0	40.4	2.8	16.4	54
2573.500000	39.5	100.0	V	0.0	44.8	5.3	14.5	54
2768.000000	39.1	100.0	V	235.0	44.8	5.7	14.9	54

Remark: 1. Correction Factor = Antenna factor+ Insertion loss (cable loss + amplifier gain)

RE 3G-18GHz PK+AV Class B

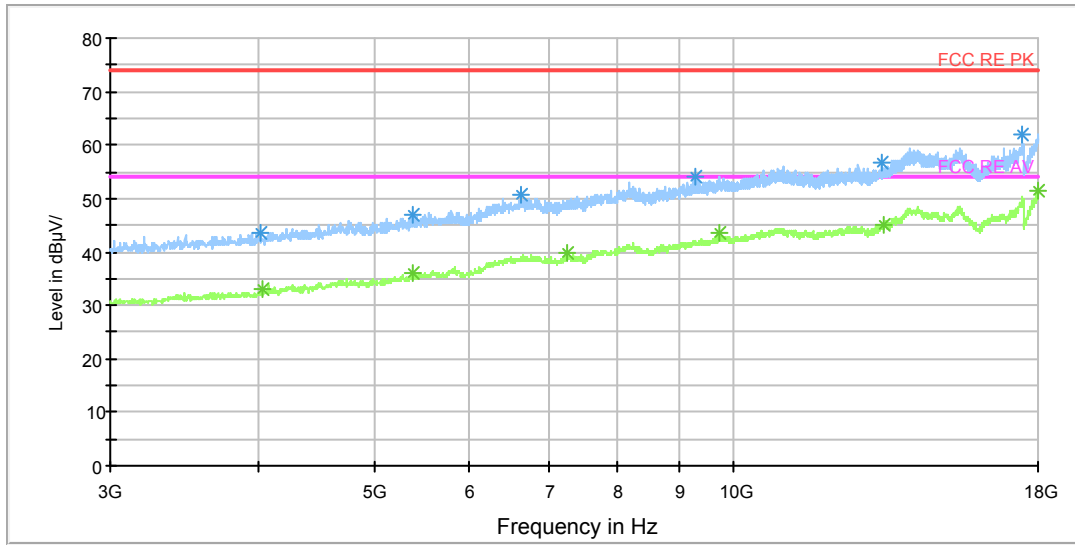

Radiates Emission from 3GHz to 18GHz

Frequency (MHz)	Peak (dBuV/m)	Height (cm)	Polarization	Azimuth (deg)	Reading value (dBuV/m)	Correct Factor (dB)	Margin (dB)	Limit (dBuV/m)
4008.000000	43.6	100.0	H	0.0	45.6	-2.0	30.4	74
5373.000000	46.8	100.0	H	1.0	47.7	0.9	27.2	74
6642.000000	50.5	100.0	H	0.0	55.6	5.1	23.5	74
9282.000000	54.1	100.0	V	192.0	64.1	10.0	19.9	74
13299.000000	56.9	100.0	V	0.0	74.6	17.7	17.1	74
17472.000000	62.0	100.0	H	294.0	85.8	23.8	12.0	74

Remark: 1. Correction Factor = Antenna factor+ Insertion loss (cable loss + amplifier gain)

Frequency (MHz)	Average (dBuV/m)	Height (cm)	Polarization	Azimuth (deg)	Reading value (dBuV/m)	Correct Factor (dB)	Margin (dB)	Limit (dBuV/m)
4029.000000	33.0	100.0	V	173.0	35.0	-2.0	21.0	54
5388.000000	36.0	100.0	H	0.0	37.0	1.0	18.0	54
7251.000000	39.7	100.0	H	118.0	45.2	5.5	14.3	54
9711.000000	43.4	100.0	H	186.0	54.5	11.1	10.6	54
13338.000000	45.1	100.0	H	12.0	62.9	17.8	8.9	54
17988.000000	51.4	100.0	V	354.0	77.1	25.7	2.6	54

Remark: 1. Correction Factor = Antenna factor+ Insertion loss (cable loss + amplifier gain)

RE 18-26.5GHz PK+AV

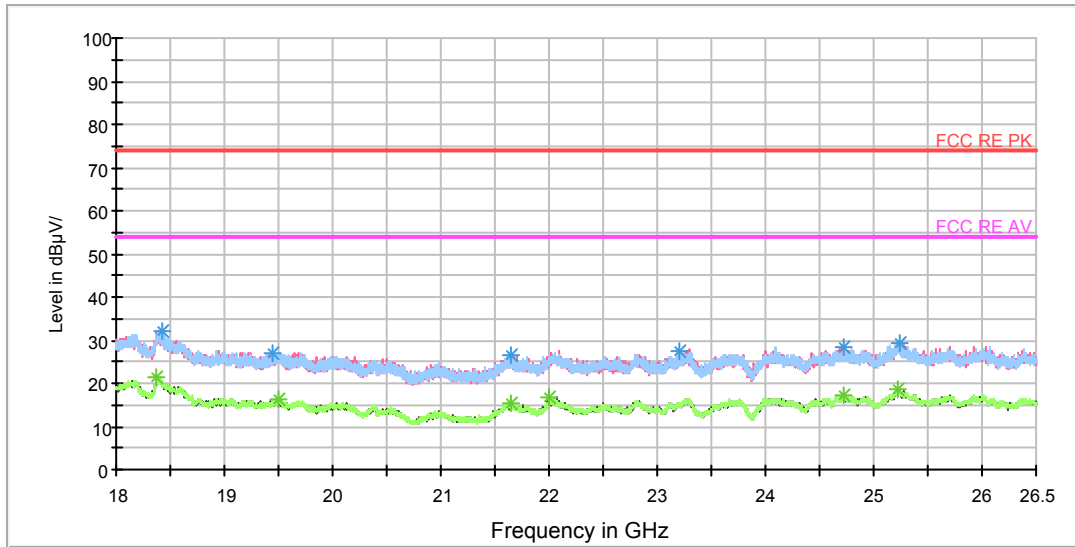

Radiates Emission from 18GHz to 26.5GHz

Frequency (MHz)	Peak (dBuV/m)	Polarization	Azimuth (deg)	Reading value (dBuV/m)	Correct Factor (dB)	Margin (dB)	Limit (dBuV/m)
18420.750000	31.9	H	0.0	37.1	-5.2	42.1	74
19435.437500	27.0	H	13.0	35.1	-8.1	47.0	74
21651.812500	26.7	V	97.0	35.9	-9.2	47.3	74
23199.875000	27.3	H	0.0	35.8	-8.5	46.7	74
24727.750000	28.3	V	167.0	34.5	-6.2	45.7	74
25234.562500	29.5	H	36.0	35.5	-6.0	44.5	74

Remark: 1. Correction Factor = Antenna factor+ Insertion loss (cable loss + amplifier gain)

Frequency (MHz)	Average (dBuV/m)	Polarization	Azimuth (deg)	Reading value (dBuV/m)	Correct Factor (dB)	Margin (dB)	Limit (dBuV/m)
18375.062500	21.3	V	160.0	26.0	-4.7	32.7	54
19496.000000	16.3	V	180.0	23.9	-7.6	37.7	54
21650.750000	15.3	H	75.0	24.5	-9.2	38.7	54
22008.812500	16.7	H	28.0	24.9	-8.2	37.3	54
24727.750000	17.3	V	167.0	23.5	-6.2	36.7	54
25231.375000	18.7	V	121.0	24.6	-5.9	35.3	54

Remark: 1. Correction Factor = Antenna factor+ Insertion loss (cable loss + amplifier gain)



802.11b CH6

FCC RE 0.03-1GHz QP Class C

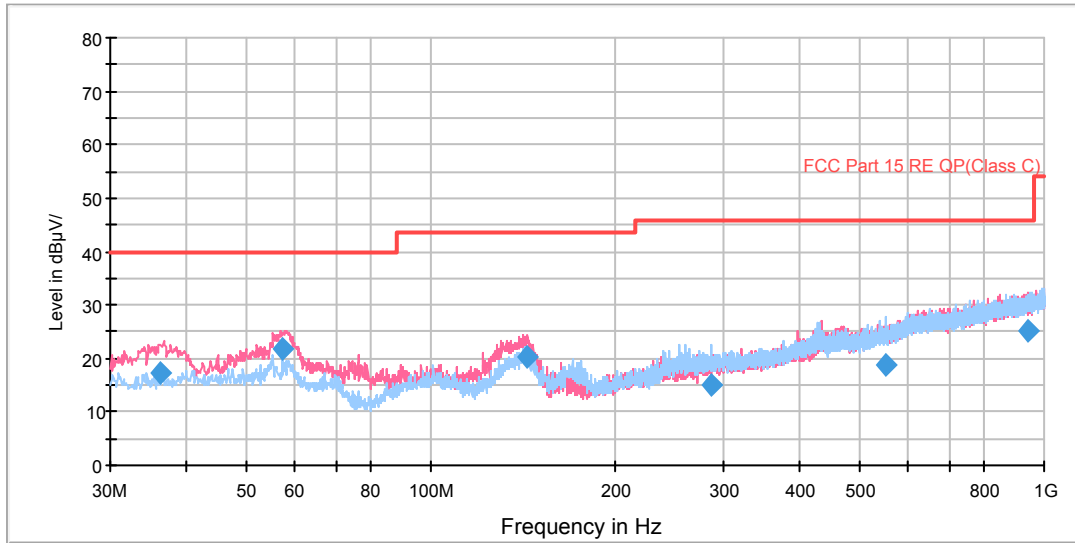

Radiates Emission from 30MHz to 1GHz

Frequency (MHz)	Quasi-Peak (dBuV/m)	Height (cm)	Polarization	Azimuth (deg)	Reading value (dBuV/m)	Correct Factor (dB)	Margin (dB)	Limit (dBuV/m)
36.188750	17.2	100.0	V	256.0	29.4	12.2	22.8	40.0
57.437500	21.7	125.0	V	188.0	34.3	12.6	18.3	40.0
143.375000	20.1	114.0	V	293.0	29.1	9.0	23.4	43.5
287.451250	15.0	113.0	H	140.0	30.1	15.1	31.0	46.0
553.718750	18.7	125.0	H	309.0	39.9	21.2	27.3	46.0
943.862500	25.0	125.0	V	356.0	51.1	26.1	21.0	46.0

- Remark: 1. Quasi-Peak = Reading value + Correction factor
 2. Correction Factor = Antenna factor+ Insertion loss(cable loss+amplifier gain)
 3. Margin = Limit – Quasi-Peak

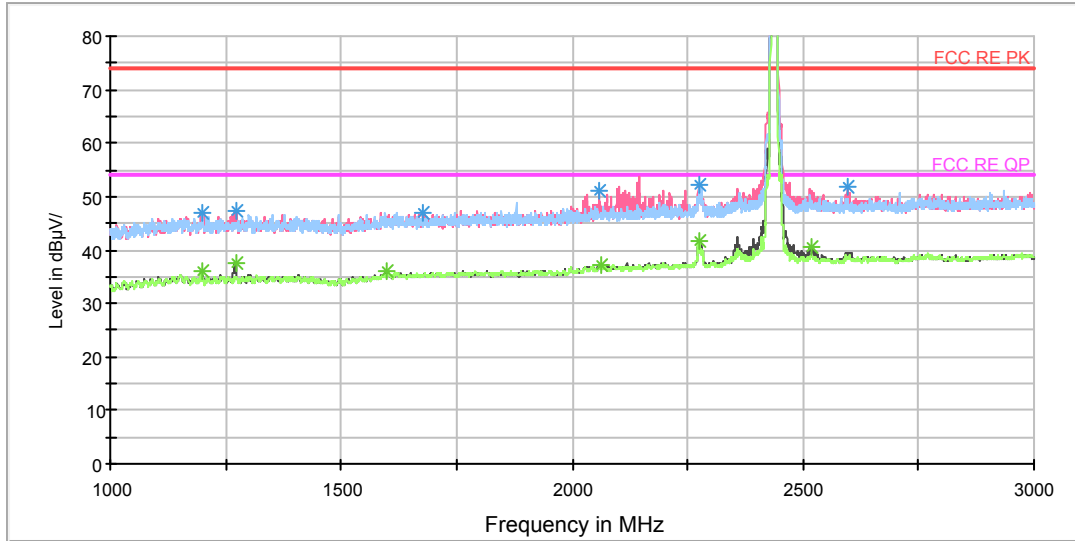

Note: The signal beyond the limit is carrier.

Radiates Emission from 1GHz to 3GHz

Frequency (MHz)	Peak (dBuV/m)	Height (cm)	Polarization	Azimuth (deg)	Reading value (dBuV/m)	Correct Factor (dB)	Margin (dB)	Limit (dBuV/m)
1198.000000	47.1	100.0	H	132.0	47.8	-0.7	26.9	74
1274.500000	47.2	100.0	V	359.0	47.5	-0.3	26.8	74
1677.500000	46.9	100.0	V	353.0	48.1	1.2	27.1	74
2059.500000	51.0	100.0	V	0.0	53.6	2.6	23.0	74
2275.500000	52.2	100.0	V	356.0	56.0	3.8	21.8	74
2597.000000	51.9	100.0	V	0.0	57.2	5.3	22.1	74

Remark: 1. Correction Factor = Antenna factor+ Insertion loss (cable loss + amplifier gain)

Frequency (MHz)	Average (dBuV/m)	Height (cm)	Polarization	Azimuth (deg)	Reading value (dBuV/m)	Correct Factor (dB)	Margin (dB)	Limit (dBuV/m)
1197.500000	36.0	100.0	H	38.0	36.7	-0.7	18.0	54
1271.500000	37.6	100.0	V	0.0	37.9	-0.3	16.4	54
1597.500000	36.1	100.0	V	142.0	37.1	1.0	17.9	54
2061.000000	37.2	100.0	V	0.0	39.8	2.6	16.8	54
2274.000000	41.7	100.0	H	155.0	45.5	3.8	12.3	54
2517.000000	40.7	100.0	V	127.0	45.8	5.1	13.3	54

Remark: 1. Correction Factor = Antenna factor+ Insertion loss (cable loss + amplifier gain)

RE 3G-18GHz PK+AV Class B

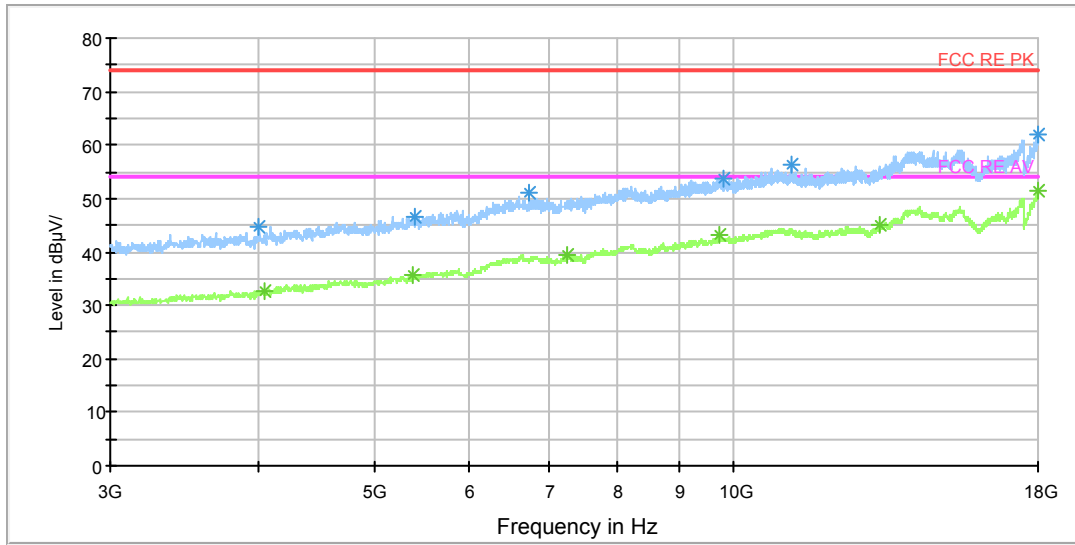

Radiates Emission from 3GHz to 18GHz

Frequency (MHz)	Peak (dBuV/m)	Height (cm)	Polarization	Azimuth (deg)	Reading value (dBuV/m)	Correct Factor (dB)	Margin (dB)	Limit (dBuV/m)
4002.000000	44.6	100.0	V	192.0	46.7	-2.1	29.4	74
5406.000000	46.7	100.0	V	335.0	47.8	1.1	27.3	74
6735.000000	51.0	100.0	V	269.0	56.0	5.0	23.0	74
9819.000000	53.8	100.0	H	187.0	64.9	11.1	20.2	74
11199.000000	56.2	100.0	H	3.0	70.9	14.7	17.8	74
17991.000000	61.9	100.0	V	230.0	87.6	25.7	12.1	74

Remark: 1. Correction Factor = Antenna factor+ Insertion loss (cable loss + amplifier gain)

Frequency (MHz)	Average (dBuV/m)	Height (cm)	Polarization	Azimuth (deg)	Reading value (dBuV/m)	Correct Factor (dB)	Margin (dB)	Limit (dBuV/m)
4038.000000	32.8	100.0	V	221.0	34.7	-1.9	21.2	54
5385.000000	35.8	100.0	H	4.0	36.7	0.9	18.2	54
7254.000000	39.5	100.0	V	240.0	45.0	5.5	14.5	54
9744.000000	43.3	100.0	H	4.0	54.4	11.1	10.7	54
13251.000000	45.2	100.0	V	0.0	62.8	17.6	8.8	54
17988.000000	51.4	100.0	H	216.0	77.1	25.7	2.6	54

Remark: 1. Correction Factor = Antenna factor+ Insertion loss (cable loss + amplifier gain)

RE 18-26.5GHz PK+AV

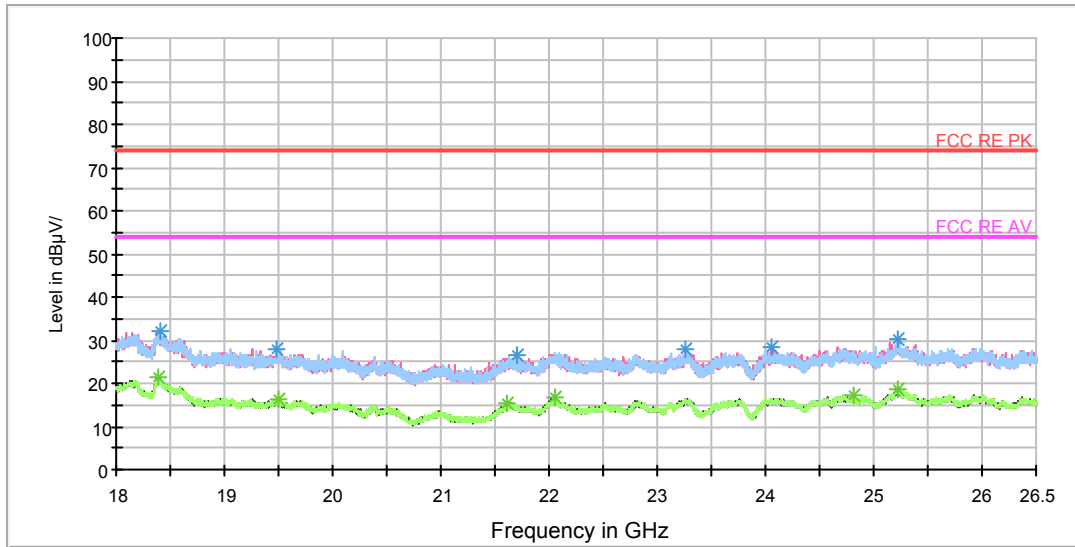

Radiates Emission from 18GHz to 26.5GHz

Frequency (MHz)	Peak (dBuV/m)	Polarization	Azimuth (deg)	Reading value (dBuV/m)	Correct Factor (dB)	Margin (dB)	Limit (dBuV/m)
18405.875000	32.3	V	176.0	37.3	-5.0	41.7	74
19486.437500	28.1	V	176.0	35.8	-7.7	45.9	74
21711.312500	26.3	H	0.0	35.7	-9.4	47.7	74
23265.750000	28.0	V	82.0	35.3	-7.3	46.0	74
24053.062500	28.3	V	180.0	36.1	-7.8	45.7	74
25216.500000	30.4	V	159.0	36.5	-6.1	43.6	74

Remark: 1. Correction Factor = Antenna factor+ Insertion loss (cable loss + amplifier gain)

Frequency (MHz)	Average (dBuV/m)	Polarization	Azimuth (deg)	Reading value (dBuV/m)	Correct Factor (dB)	Margin (dB)	Limit (dBuV/m)
18387.812500	21.2	V	121.0	26.1	-4.9	32.8	54
19504.500000	16.3	H	7.0	23.8	-7.5	37.7	54
21617.812500	15.2	H	54.0	24.2	-9.0	38.8	54
22051.312500	16.6	H	15.0	24.7	-8.1	37.4	54
24809.562500	17.2	H	100.0	23.9	-6.7	36.8	54
25223.937500	18.7	V	180.0	24.6	-5.9	35.3	54

Remark: 1. Correction Factor = Antenna factor+ Insertion loss (cable loss + amplifier gain)



802.11b CH11

FCC RE 0.03-1GHz QP Class C

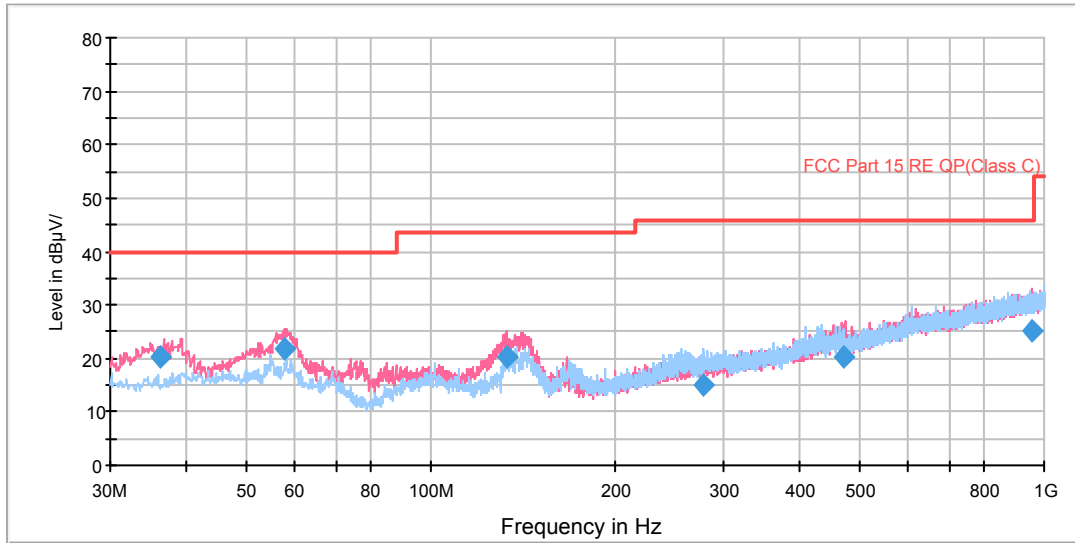

Radiates Emission from 30MHz to 1GHz

Frequency (MHz)	Quasi-Peak (dBuV/m)	Height (cm)	Polarization	Azimuth (deg)	Reading value (dBuV/m)	Correct Factor (dB)	Margin (dB)	Limit (dBuV/m)
36.148750	20.1	100.0	V	306.0	32.3	12.2	19.9	40.0
57.770000	21.6	125.0	V	226.0	34.2	12.6	18.4	40.0
132.898750	20.5	114.0	V	339.0	29.7	9.2	23.0	43.5
277.956250	15.1	100.0	H	335.0	29.9	14.8	30.9	46.0
472.527500	20.4	100.0	V	0.0	39.7	19.3	25.6	46.0
956.950000	25.1	100.0	V	12.0	51.2	26.1	20.9	46.0

- Remark: 1. Quasi-Peak = Reading value + Correction factor
- 2. Correction Factor = Antenna factor+ Insertion loss(cable loss+amplifier gain)
- 3. Margin = Limit – Quasi-Peak

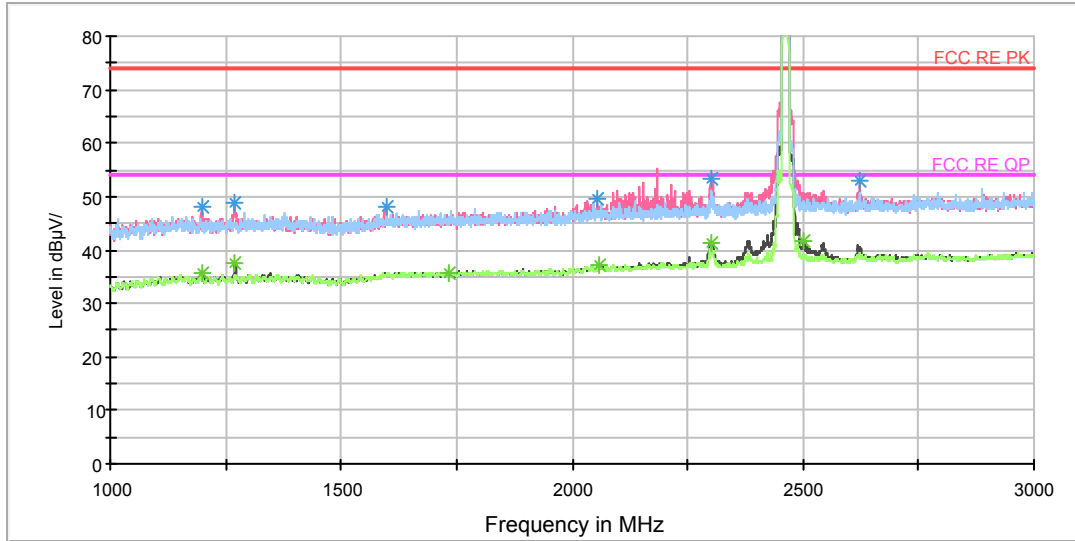

Note: The signal beyond the limit is carrier.

Radiates Emission from 1GHz to 3GHz

Frequency (MHz)	Peak (dBuV/m)	Height (cm)	Polarization	Azimuth (deg)	Reading value (dBuV/m)	Correct Factor (dB)	Margin (dB)	Limit (dBuV/m)
1197.500000	48.2	100.0	V	357.0	48.9	-0.7	25.8	74
1270.000000	48.9	100.0	V	0.0	49.2	-0.3	25.1	74
1598.500000	48.3	100.0	V	150.0	49.3	1.0	25.7	74
2053.000000	49.4	100.0	V	0.0	52.0	2.6	24.6	74
2303.000000	53.3	100.0	V	358.0	57.3	4.0	20.7	74
2622.000000	53.0	100.0	V	359.0	58.4	5.4	21.0	74

Remark: 1. Correction Factor = Antenna factor+ Insertion loss (cable loss + amplifier gain)

Frequency (MHz)	Average (dBuV/m)	Height (cm)	Polarization	Azimuth (deg)	Reading value (dBuV/m)	Correct Factor (dB)	Margin (dB)	Limit (dBuV/m)
1198.000000	35.7	100.0	V	359.0	36.4	-0.7	18.3	54
1270.000000	37.7	100.0	V	0.0	38.0	-0.3	16.3	54
1731.500000	35.9	100.0	V	259.0	37.3	1.4	18.1	54
2058.000000	37.0	100.0	H	3.0	39.6	2.6	17.0	54
2300.000000	41.4	100.0	V	0.0	45.4	4.0	12.6	54
2499.500000	41.8	100.0	V	359.0	46.8	5.0	12.2	54

Remark: 1. Correction Factor = Antenna factor+ Insertion loss (cable loss + amplifier gain)

RE 3G-18GHz PK+AV Class B

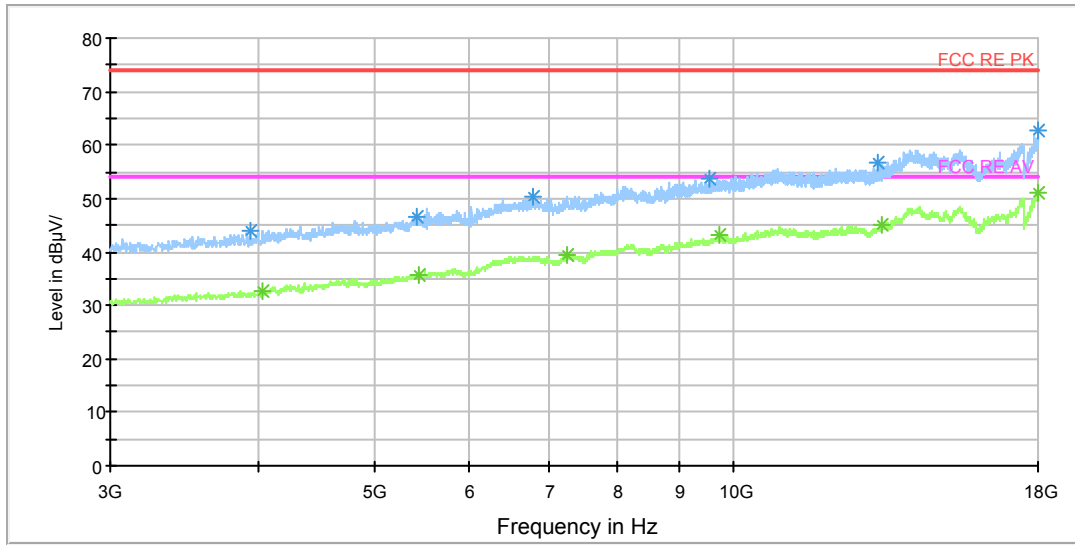

Radiates Emission from 3GHz to 18GHz

Frequency (MHz)	Peak (dBuV/m)	Height (cm)	Polarization	Azimuth (deg)	Reading value (dBuV/m)	Correct Factor (dB)	Margin (dB)	Limit (dBuV/m)
3927.000000	43.8	100.0	H	7.0	45.9	-2.1	30.2	74
5430.000000	46.6	100.0	H	15.0	47.8	1.2	27.4	74
6792.000000	50.5	100.0	H	3.0	55.5	5.0	23.5	74
9552.000000	53.8	100.0	V	347.0	64.3	10.5	20.2	74
13200.000000	56.6	100.0	V	241.0	74.1	17.5	17.4	74
17970.000000	62.5	100.0	H	127.0	88.0	25.5	11.5	74

Remark: 1. Correction Factor = Antenna factor+ Insertion loss (cable loss + amplifier gain)

Frequency (MHz)	Average (dBuV/m)	Height (cm)	Polarization	Azimuth (deg)	Reading value (dBuV/m)	Correct Factor (dB)	Margin (dB)	Limit (dBuV/m)
4023.000000	32.6	100.0	H	3.0	34.6	-2.0	21.4	54
5439.000000	35.7	100.0	H	46.0	36.9	1.2	18.3	54
7257.000000	39.5	100.0	V	231.0	45.0	5.5	14.5	54
9717.000000	43.1	100.0	V	354.0	54.2	11.1	10.9	54
13293.000000	45.0	100.0	V	356.0	62.7	17.7	9.0	54
17988.000000	51.2	100.0	V	134.0	76.9	25.7	2.8	54

Remark: 1. Correction Factor = Antenna factor+ Insertion loss (cable loss + amplifier gain)

RE 18-26.5GHz PK+AV

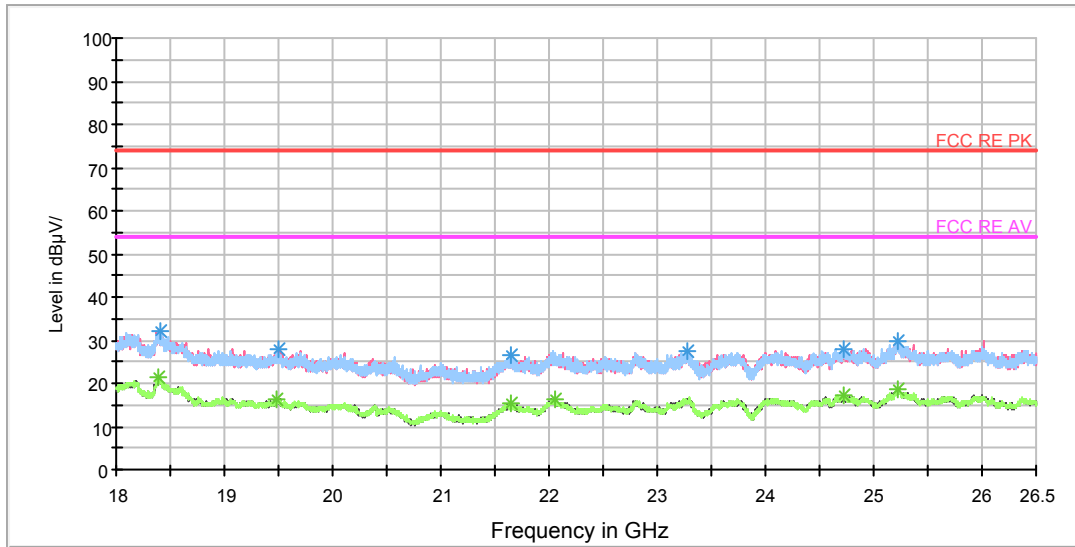

Radiates Emission from 18GHz to 26.5GHz

Frequency (MHz)	Peak (dBuV/m)	Polarization	Azimuth (deg)	Reading value (dBuV/m)	Correct Factor (dB)	Margin (dB)	Limit (dBuV/m)
18402.687500	32.2	V	103.0	37.1	-4.9	41.8	74
19506.625000	27.7	V	180.0	35.2	-7.5	46.3	74
21639.062500	26.7	H	10.0	35.8	-9.1	47.3	74
23278.500000	27.5	H	139.0	34.7	-7.2	46.5	74
24730.937500	28.1	H	24.0	34.3	-6.2	45.9	74
25231.375000	29.8	H	0.0	35.7	-5.9	44.2	74

Remark: 1. Correction Factor = Antenna factor+ Insertion loss (cable loss + amplifier gain)

Frequency (MHz)	Average (dBuV/m)	Polarization	Azimuth (deg)	Reading value (dBuV/m)	Correct Factor (dB)	Margin (dB)	Limit (dBuV/m)
18396.312500	21.5	H	131.0	26.4	-4.9	32.5	54
19472.625000	16.4	H	0.0	24.3	-7.9	37.6	54
21655.000000	15.2	H	48.0	24.4	-9.2	38.8	54
22054.500000	16.4	V	180.0	24.5	-8.1	37.6	54
24728.812500	17.1	H	0.0	23.3	-6.2	36.9	54
25228.187500	18.7	H	48.0	24.6	-5.9	35.3	54

Remark: 1. Correction Factor = Antenna factor+ Insertion loss (cable loss + amplifier gain)



802.11g CH1

FCC RE 0.03-1GHz QP Class C

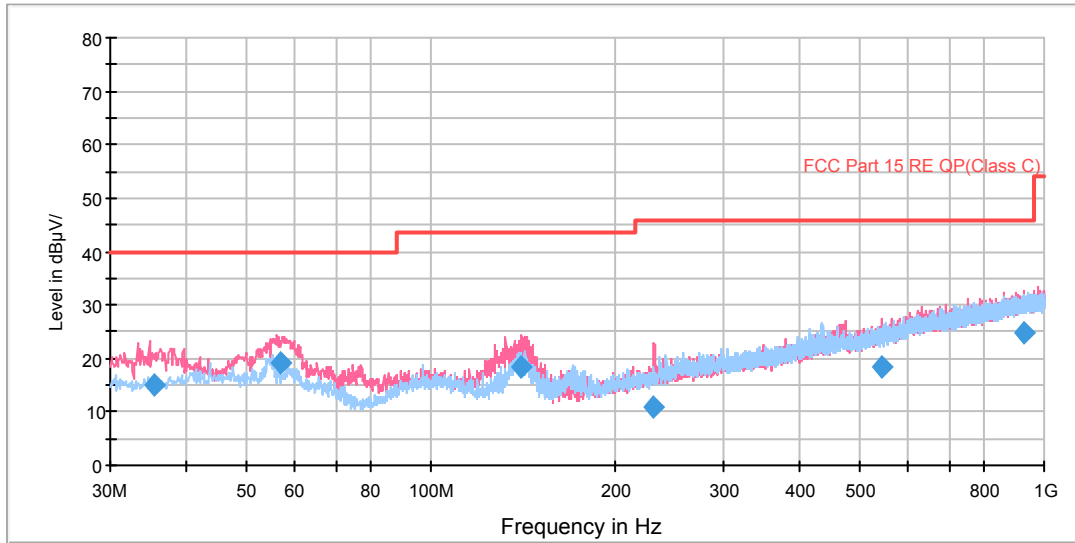

Radiates Emission from 30MHz to 1GHz

Frequency (MHz)	Quasi-Peak (dBuV/m)	Height (cm)	Polarization	Azimuth (deg)	Reading value (dBuV/m)	Correct Factor (dB)	Margin (dB)	Limit (dBuV/m)
35.290000	15.2	100.0	V	249.0	27.1	11.9	24.8	40.0
56.750000	19.0	125.0	V	234.0	31.6	12.6	21.0	40.0
140.662500	18.3	114.0	V	330.0	27.2	8.9	25.2	43.5
230.956250	10.8	100.0	V	202.0	24.1	13.3	35.2	46.0
545.548750	18.6	125.0	V	145.0	39.5	20.9	27.4	46.0
929.507500	24.9	100.0	V	302.0	50.8	25.9	21.1	46.0

- Remark: 1. Quasi-Peak = Reading value + Correction factor
 2. Correction Factor = Antenna factor+ Insertion loss(cable loss+amplifier gain)
 3. Margin = Limit – Quasi-Peak

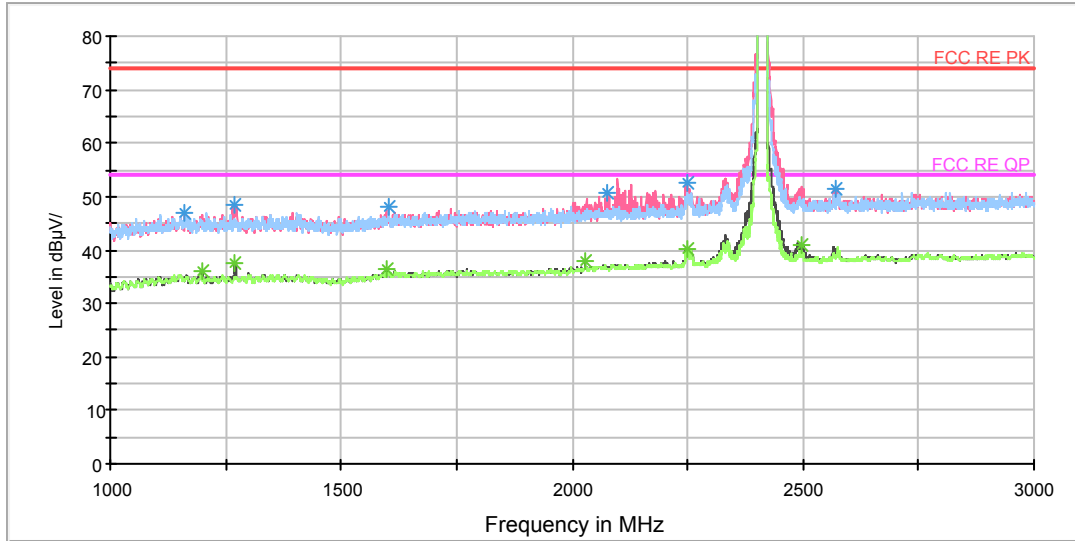

Note: The signal beyond the limit is carrier.

Radiates Emission from 1GHz to 3GHz

Frequency (MHz)	Peak (dBuV/m)	Height (cm)	Polarization	Azimuth (deg)	Reading value (dBuV/m)	Correct Factor (dB)	Margin (dB)	Limit (dBuV/m)
1162.500000	46.9	100.0	V	118.0	47.7	-0.8	27.1	74
1268.000000	48.5	100.0	V	0.0	48.8	-0.3	25.5	74
1602.500000	48.0	100.0	V	0.0	49.0	1.0	26.0	74
2078.000000	50.6	100.0	V	0.0	53.3	2.7	23.4	74
2250.500000	52.4	100.0	V	0.0	56.1	3.7	21.6	74
2571.500000	51.5	100.0	V	0.0	56.8	5.3	22.5	74

Remark: 1. Correction Factor = Antenna factor+ Insertion loss (cable loss + amplifier gain)

Frequency (MHz)	Average (dBuV/m)	Height (cm)	Polarization	Azimuth (deg)	Reading value (dBuV/m)	Correct Factor (dB)	Margin (dB)	Limit (dBuV/m)
1197.500000	36.0	100.0	V	0.0	36.7	-0.7	18.0	54
1269.500000	37.5	100.0	V	0.0	37.8	-0.3	16.5	54
1598.500000	36.4	100.0	V	149.0	37.4	1.0	17.6	54
2027.000000	37.8	100.0	V	0.0	40.2	2.4	16.2	54
2250.500000	40.3	100.0	V	0.0	44.0	3.7	13.7	54
2498.500000	40.8	100.0	V	0.0	45.8	5.0	13.2	54

Remark: 1. Correction Factor = Antenna factor+ Insertion loss (cable loss + amplifier gain)

RE 3G-18GHz PK+AV Class B

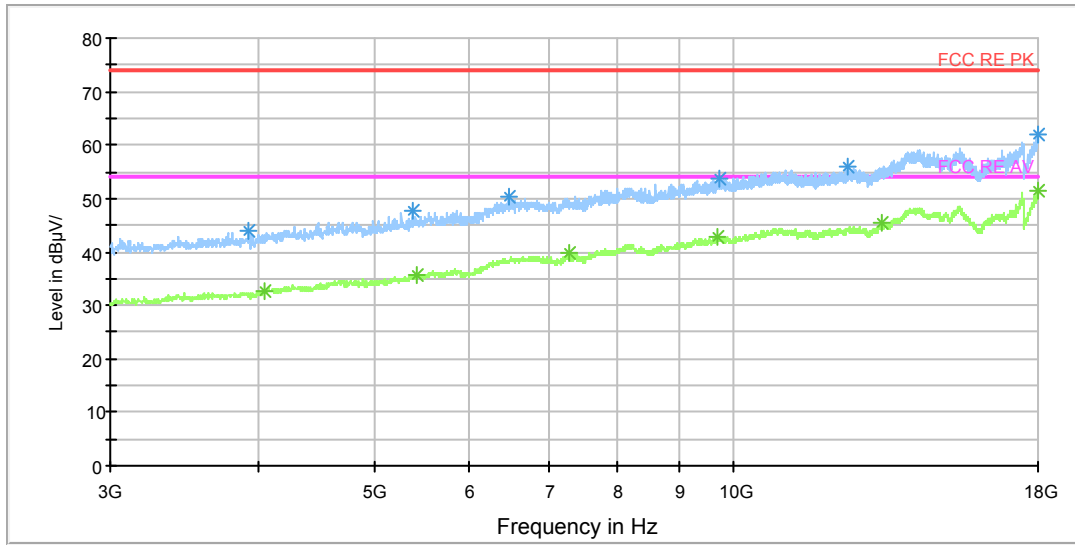

Radiates Emission from 3GHz to 18GHz

Frequency (MHz)	Peak (dBuV/m)	Height (cm)	Polarization	Azimuth (deg)	Reading value (dBuV/m)	Correct Factor (dB)	Margin (dB)	Limit (dBuV/m)
3924.000000	44.0	100.0	V	76.0	46.1	-2.1	30.0	74
5388.000000	47.7	100.0	V	357.0	48.7	1.0	26.3	74
6468.000000	50.4	100.0	V	0.0	55.7	5.3	23.6	74
9714.000000	53.9	100.0	H	139.0	65.0	11.1	20.1	74
12486.000000	55.8	100.0	V	316.0	71.8	16.0	18.2	74
17970.000000	61.9	100.0	H	13.0	87.4	25.5	12.1	74

Remark: 1. Correction Factor = Antenna factor+ Insertion loss (cable loss + amplifier gain)

Frequency (MHz)	Average (dBuV/m)	Height (cm)	Polarization	Azimuth (deg)	Reading value (dBuV/m)	Correct Factor (dB)	Margin (dB)	Limit (dBuV/m)
4038.000000	32.6	100.0	H	19.0	34.5	-1.9	21.4	54
5430.000000	35.8	100.0	V	316.0	37.0	1.2	18.2	54
7266.000000	39.9	100.0	V	211.0	45.5	5.6	14.1	54
9702.000000	42.9	100.0	V	354.0	54.0	11.1	11.1	54
13329.000000	45.3	100.0	H	217.0	63.0	17.7	8.7	54
17988.000000	51.3	100.0	H	266.0	77.0	25.7	2.7	54

Remark: 1. Correction Factor = Antenna factor+ Insertion loss (cable loss + amplifier gain)

RE 18-26.5GHz PK+AV

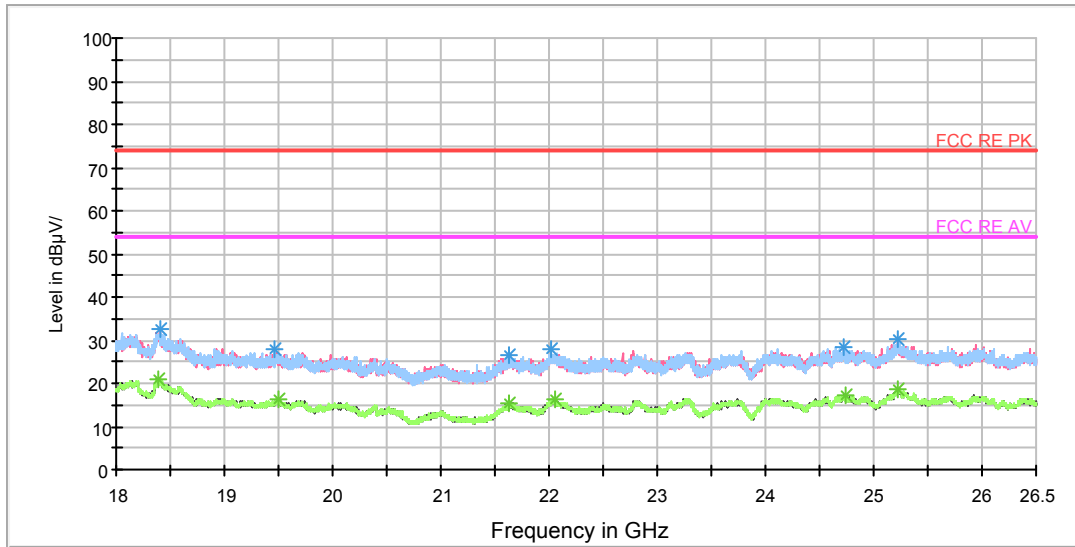

Radiates Emission from 18GHz to 26.5GHz

Frequency (MHz)	Peak (dBuV/m)	Polarization	Azimuth (deg)	Reading value (dBuV/m)	Correct Factor (dB)	Margin (dB)	Limit (dBuV/m)
18398.437500	32.4	V	170.0	37.3	-4.9	41.6	74
19457.750000	27.8	H	49.0	36.0	-8.2	46.2	74
21633.750000	26.4	V	49.0	35.5	-9.1	47.6	74
22020.500000	27.9	H	49.0	35.9	-8.0	46.1	74
24724.562500	28.3	H	66.0	34.5	-6.2	45.7	74
25225.000000	30.4	V	170.0	36.3	-5.9	43.6	74

Remark: 1. Correction Factor = Antenna factor+ Insertion loss (cable loss + amplifier gain)

Frequency (MHz)	Average (dBuV/m)	Polarization	Azimuth (deg)	Reading value (dBuV/m)	Correct Factor (dB)	Margin (dB)	Limit (dBuV/m)
18385.687500	21.1	H	176.0	25.9	-4.8	32.9	54
19491.750000	16.5	H	82.0	24.1	-7.6	37.5	54
21626.312500	15.2	V	154.0	24.3	-9.1	38.8	54
22051.312500	16.3	H	73.0	24.4	-8.1	37.7	54
24733.062500	17.1	V	138.0	23.4	-6.3	36.9	54
25225.000000	18.8	V	170.0	24.7	-5.9	35.2	54

Remark: 1. Correction Factor = Antenna factor+ Insertion loss (cable loss + amplifier gain)



802.11g CH6

FCC RE 0.03-1GHz QP Class C

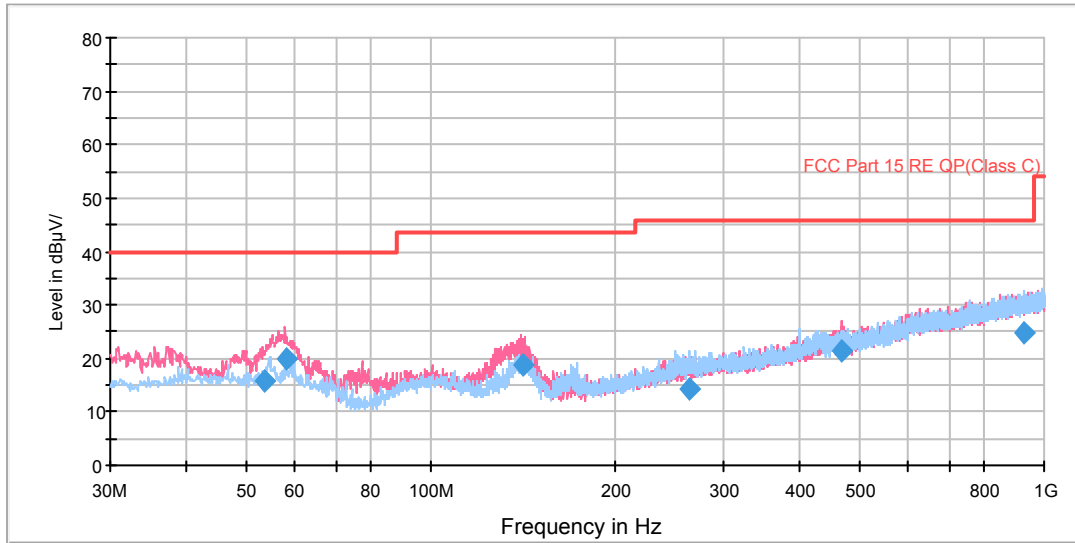

Radiates Emission from 30MHz to 1GHz

Frequency (MHz)	Quasi-Peak (dBuV/m)	Height (cm)	Polarization	Azimuth (deg)	Reading value (dBuV/m)	Correct Factor (dB)	Margin (dB)	Limit (dBuV/m)
53.718750	15.9	100.0	V	0.0	28.7	12.8	24.1	40.0
58.127500	20.1	125.0	V	210.0	32.7	12.6	19.9	40.0
140.898750	18.9	100.0	V	293.0	27.8	8.9	24.6	43.5
263.845000	14.3	100.0	H	341.0	28.8	14.5	31.7	46.0
469.041250	21.4	100.0	V	0.0	40.7	19.3	24.6	46.0
930.808750	24.8	100.0	H	9.0	50.7	25.9	21.2	46.0

- Remark: 1. Quasi-Peak = Reading value + Correction factor
- 2. Correction Factor = Antenna factor+ Insertion loss(cable loss+amplifier gain)
- 3. Margin = Limit – Quasi-Peak

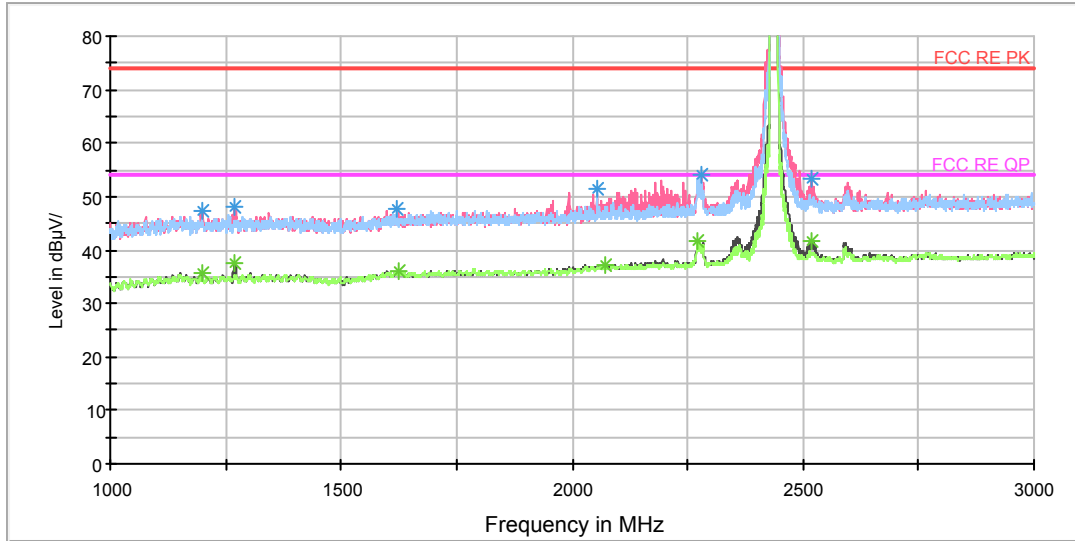

Note: The signal beyond the limit is carrier.

Radiates Emission from 1GHz to 3GHz

Frequency (MHz)	Peak (dBuV/m)	Height (cm)	Polarization	Azimuth (deg)	Reading value (dBuV/m)	Correct Factor (dB)	Margin (dB)	Limit (dBuV/m)
1198.000000	47.5	100.0	V	199.0	48.2	-0.7	26.5	74
1268.500000	48.0	100.0	V	0.0	48.3	-0.3	26.0	74
1621.000000	47.7	100.0	H	115.0	48.8	1.1	26.3	74
2055.500000	51.5	100.0	H	0.0	54.1	2.6	22.5	74
2278.500000	53.9	100.0	V	356.0	57.7	3.8	20.1	74
2517.500000	53.3	100.0	V	126.0	58.4	5.1	20.7	74

Remark: 1. Correction Factor = Antenna factor+ Insertion loss (cable loss + amplifier gain)

Frequency (MHz)	Average (dBuV/m)	Height (cm)	Polarization	Azimuth (deg)	Reading value (dBuV/m)	Correct Factor (dB)	Margin (dB)	Limit (dBuV/m)
1198.000000	35.7	100.0	V	199.0	36.4	-0.7	18.3	54
1269.000000	37.5	100.0	V	352.0	37.8	-0.3	16.5	54
1626.500000	36.0	100.0	H	14.0	37.1	1.1	18.0	54
2071.500000	37.2	100.0	V	0.0	39.9	2.7	16.8	54
2270.500000	41.7	100.0	H	154.0	45.5	3.8	12.3	54
2518.500000	41.8	100.0	V	0.0	46.9	5.1	12.2	54

Remark: 1. Correction Factor = Antenna factor+ Insertion loss (cable loss + amplifier gain)

RE 3G-18GHz PK+AV Class B

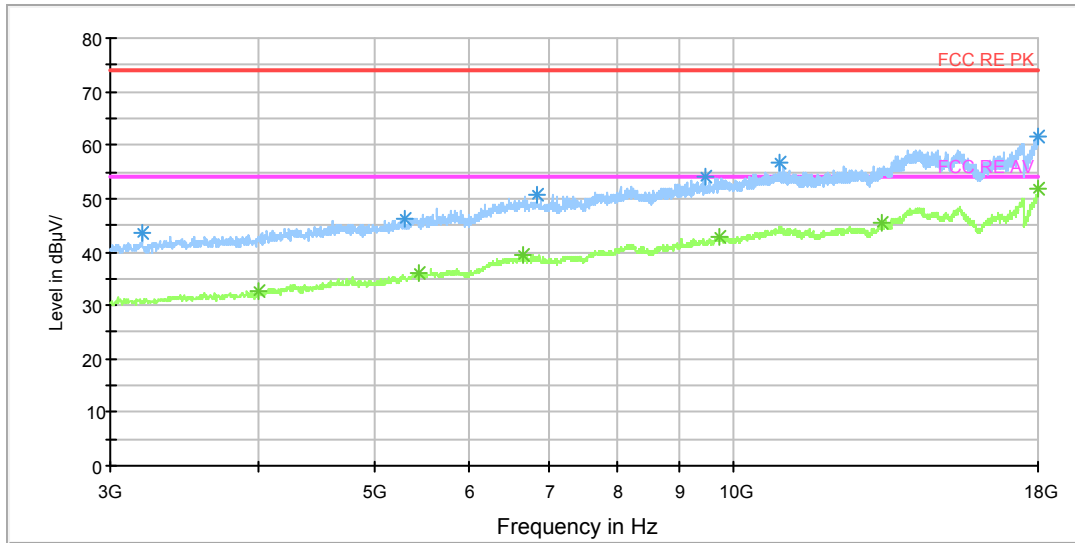

Radiates Emission from 3GHz to 18GHz

Frequency (MHz)	Peak (dBuV/m)	Height (cm)	Polarization	Azimuth (deg)	Reading value (dBuV/m)	Correct Factor (dB)	Margin (dB)	Limit (dBuV/m)
3189.000000	43.7	100.0	V	212.0	47.1	-3.4	30.3	74
5298.000000	46.4	100.0	H	4.0	46.8	0.4	27.6	74
6831.000000	50.5	100.0	H	12.0	55.5	5.0	23.5	74
9453.000000	54.3	100.0	V	221.0	64.6	10.3	19.7	74
10935.000000	56.7	100.0	V	154.0	71.2	14.5	17.3	74
17985.000000	61.5	100.0	V	221.0	87.2	25.7	12.5	74

Remark: 1. Correction Factor = Antenna factor+ Insertion loss (cable loss + amplifier gain)

Frequency (MHz)	Average (dBuV/m)	Height (cm)	Polarization	Azimuth (deg)	Reading value (dBuV/m)	Correct Factor (dB)	Margin (dB)	Limit (dBuV/m)
4002.000000	32.6	100.0	V	105.0	34.7	-2.1	21.4	54
5448.000000	35.9	100.0	V	174.0	37.1	1.2	18.1	54
6651.000000	39.5	100.0	V	308.0	44.5	5.0	14.5	54
9720.000000	42.8	100.0	H	8.0	53.9	11.1	11.2	54
13296.000000	45.4	100.0	H	128.0	63.1	17.7	8.6	54
17982.000000	51.9	100.0	H	51.0	77.5	25.6	2.1	54

Remark: 1. Correction Factor = Antenna factor+ Insertion loss (cable loss + amplifier gain)

RE 18-26.5GHz PK+AV

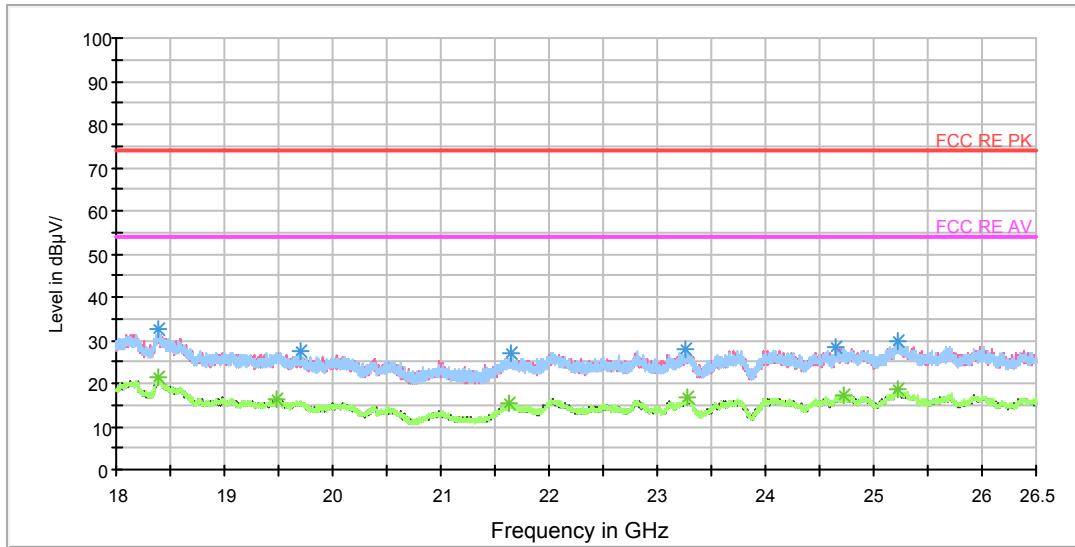

Radiates Emission from 18GHz to 26.5GHz

Frequency (MHz)	Peak (dBuV/m)	Polarization	Azimuth (deg)	Reading value (dBuV/m)	Correct Factor (dB)	Margin (dB)	Limit (dBuV/m)
18396.312500	32.6	H	0.0	37.5	-4.9	41.4	74
19694.687500	27.4	V	89.0	35.2	-7.8	46.6	74
21655.000000	26.8	H	0.0	36.0	-9.2	47.2	74
23256.187500	27.7	H	10.0	35.1	-7.4	46.3	74
24651.250000	28.3	H	18.0	35.3	-7.0	45.7	74
25228.187500	29.9	V	128.0	35.8	-5.9	44.1	74

Remark: 1. Correction Factor = Antenna factor+ Insertion loss (cable loss + amplifier gain)

Frequency (MHz)	Average (dBuV/m)	Polarization	Azimuth (deg)	Reading value (dBuV/m)	Correct Factor (dB)	Margin (dB)	Limit (dBuV/m)
18396.312500	21.2	V	180.0	26.1	-4.9	32.8	54
19482.187500	16.5	V	73.0	24.2	-7.7	37.5	54
21634.812500	15.4	H	148.0	24.5	-9.1	38.6	54
23279.562500	16.7	H	0.0	23.8	-7.1	37.3	54
24725.625000	17.1	H	75.0	23.3	-6.2	36.9	54
25218.625000	18.6	H	2.0	24.6	-6.0	35.4	54

Remark: 1. Correction Factor = Antenna factor+ Insertion loss (cable loss + amplifier gain)

802.11g CH11

FCC RE 0.03-1GHz QP Class C

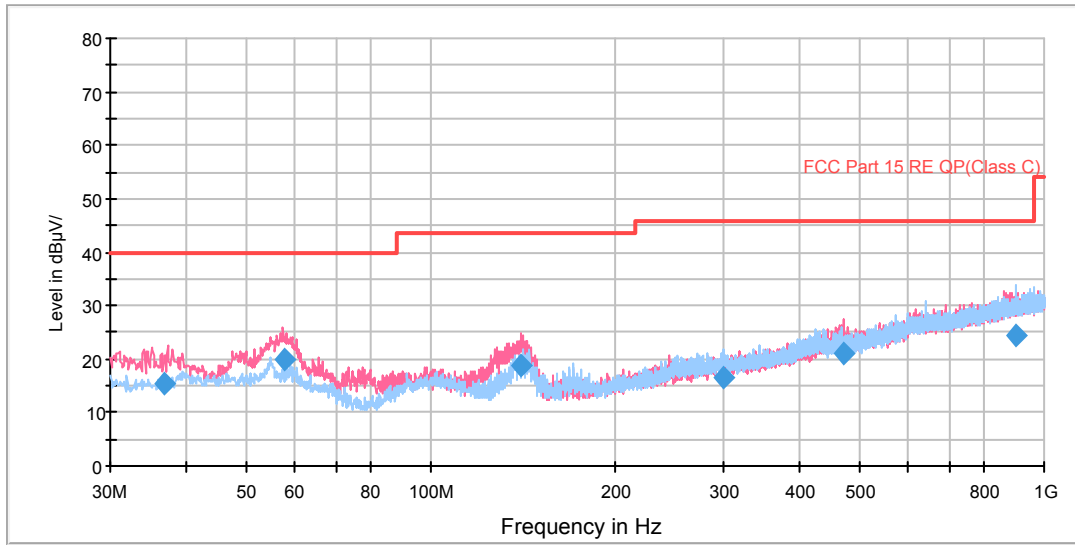

Radiates Emission from 30MHz to 1GHz

Frequency (MHz)	Quasi-Peak (dBuV/m)	Height (cm)	Polarization	Azimuth (deg)	Reading value (dBuV/m)	Correct Factor (dB)	Margin (dB)	Limit (dBuV/m)
36.755000	15.4	100.0	V	279.0	27.7	12.3	24.6	40.0
57.842500	20.0	125.0	V	218.0	32.6	12.6	20.0	40.0
140.736250	18.9	100.0	V	286.0	27.8	8.9	24.6	43.5
299.983750	16.5	100.0	H	325.0	32.0	15.5	29.5	46.0
471.067500	21.0	100.0	V	0.0	40.3	19.3	25.0	46.0
898.103750	24.4	114.0	H	22.0	50.0	25.6	21.6	46.0

- Remark: 1. Quasi-Peak = Reading value + Correction factor
 2. Correction Factor = Antenna factor+ Insertion loss(cable loss+amplifier gain)
 3. Margin = Limit – Quasi-Peak

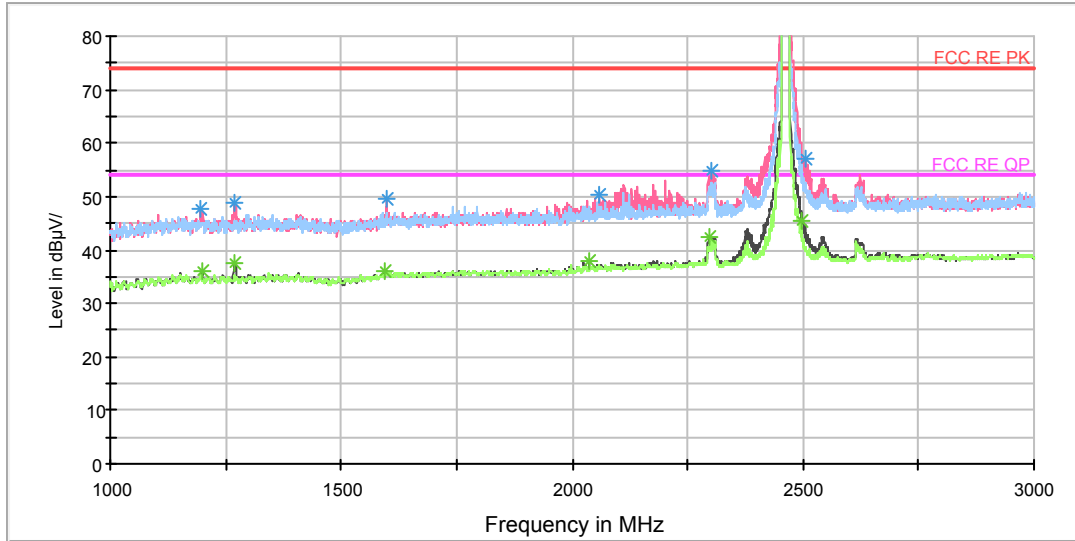

Note: The signal beyond the limit is carrier.
Radiates Emission from 1GHz to 3GHz

Frequency (MHz)	Peak (dBuV/m)	Height (cm)	Polarization	Azimuth (deg)	Reading value (dBuV/m)	Correct Factor (dB)	Margin (dB)	Limit (dBuV/m)
1196.500000	47.6	100.0	V	354.0	48.3	-0.7	26.4	74
1268.500000	48.7	100.0	V	0.0	49.0	-0.3	25.3	74
1599.500000	49.6	100.0	V	0.0	50.6	1.0	24.4	74
2059.000000	50.3	100.0	V	0.0	52.9	2.6	23.7	74
2301.000000	54.9	100.0	V	358.0	58.9	4.0	19.1	74
2505.500000	57.0	100.0	V	0.0	62.0	5.0	17.0	74

Remark: 1. Correction Factor = Antenna factor+ Insertion loss (cable loss + amplifier gain)

Frequency (MHz)	Average (dBuV/m)	Height (cm)	Polarization	Azimuth (deg)	Reading value (dBuV/m)	Correct Factor (dB)	Margin (dB)	Limit (dBuV/m)
1198.500000	35.9	100.0	V	354.0	36.6	-0.7	18.1	54
1269.000000	37.7	100.0	V	0.0	38.0	-0.3	16.3	54
1596.500000	36.0	100.0	V	143.0	37.0	1.0	18.0	54
2038.000000	38.1	100.0	V	0.0	40.6	2.5	15.9	54
2298.500000	42.3	100.0	V	359.0	46.3	4.0	11.7	54
2498.500000	45.5	100.0	V	0.0	50.5	5.0	8.5	54

Remark: 1. Correction Factor = Antenna factor+ Insertion loss (cable loss + amplifier gain)

RE 3G-18GHz PK+AV Class B

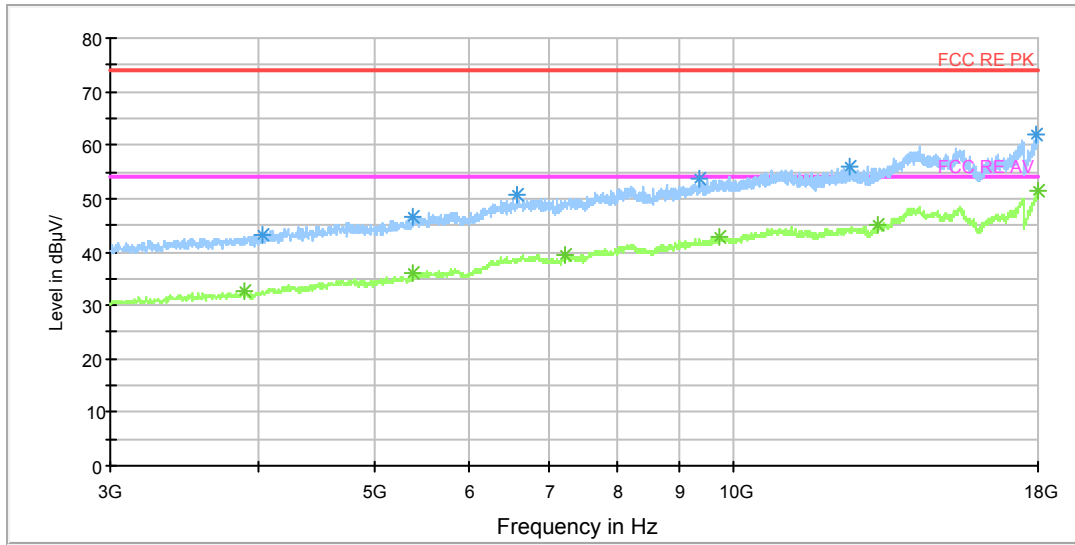

Radiates Emission from 3GHz to 18GHz

Frequency (MHz)	Peak (dBuV/m)	Height (cm)	Polarization	Azimuth (deg)	Reading value (dBuV/m)	Correct Factor (dB)	Margin (dB)	Limit (dBuV/m)
4026.000000	43.3	100.0	H	305.0	45.3	-2.0	30.7	74
5388.000000	46.7	100.0	H	24.0	47.7	1.0	27.3	74
6582.000000	50.8	100.0	H	2.0	56.0	5.2	23.2	74
9363.000000	53.6	100.0	V	356.0	63.7	10.1	20.4	74
12513.000000	56.1	100.0	V	153.0	72.1	16.0	17.9	74
17946.000000	62.1	100.0	H	24.0	87.2	25.1	11.9	74

Remark: 1. Correction Factor = Antenna factor+ Insertion loss (cable loss + amplifier gain)

Frequency (MHz)	Average (dBuV/m)	Height (cm)	Polarization	Azimuth (deg)	Reading value (dBuV/m)	Correct Factor (dB)	Margin (dB)	Limit (dBuV/m)
3882.000000	32.6	100.0	H	264.0	34.8	-2.2	21.4	54
5382.000000	36.0	100.0	H	215.0	36.9	0.9	18.0	54
7218.000000	39.5	100.0	V	351.0	45.0	5.5	14.5	54
9711.000000	42.9	100.0	V	298.0	54.0	11.1	11.1	54
13227.000000	45.0	100.0	H	274.0	62.5	17.5	9.0	54
17988.000000	51.5	100.0	V	260.0	77.2	25.7	2.5	54

Remark: 1. Correction Factor = Antenna factor+ Insertion loss (cable loss + amplifier gain)

RE 18-26.5GHz PK+AV

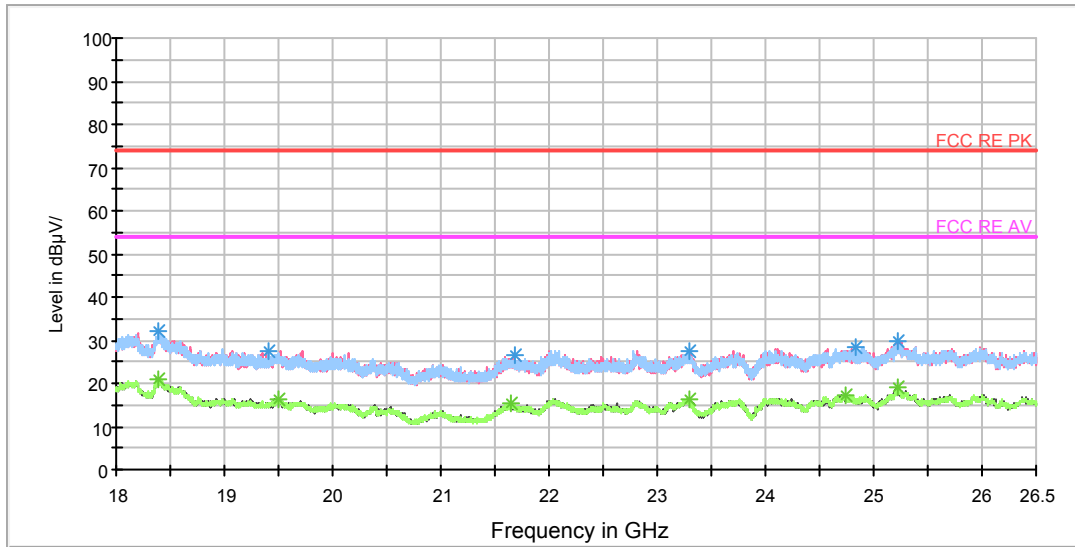

Radiates Emission from 18GHz to 26.5GHz

Frequency (MHz)	Peak (dBuV/m)	Polarization	Azimuth (deg)	Reading value (dBuV/m)	Correct Factor (dB)	Margin (dB)	Limit (dBuV/m)
18385.687500	32.2	V	180.0	37.0	-4.8	41.8	74
19412.062500	27.6	H	52.0	35.4	-7.8	46.4	74
21684.750000	26.6	H	5.0	36.0	-9.4	47.4	74
23291.250000	27.7	V	177.0	34.7	-7.0	46.3	74
24824.437500	28.2	V	177.0	35.5	-7.3	45.8	74
25226.062500	29.9	V	177.0	35.8	-5.9	44.1	74

Remark: 1. Correction Factor = Antenna factor+ Insertion loss (cable loss + amplifier gain)

Frequency (MHz)	Average (dBuV/m)	Polarization	Azimuth (deg)	Reading value (dBuV/m)	Correct Factor (dB)	Margin (dB)	Limit (dBuV/m)
18389.937500	21.0	H	13.0	25.9	-4.9	33.0	54
19491.750000	16.2	V	180.0	23.8	-7.6	37.8	54
21647.562500	15.3	V	139.0	24.5	-9.2	38.7	54
23294.437500	16.3	V	108.0	23.3	-7.0	37.7	54
24735.187500	17.3	H	0.0	23.6	-6.3	36.7	54
25223.937500	19.2	H	0.0	25.1	-5.9	34.8	54

Remark: 1. Correction Factor = Antenna factor+ Insertion loss (cable loss + amplifier gain)



802.11n (HT20) CH1

FCC RE 0.03-1GHz QP Class C

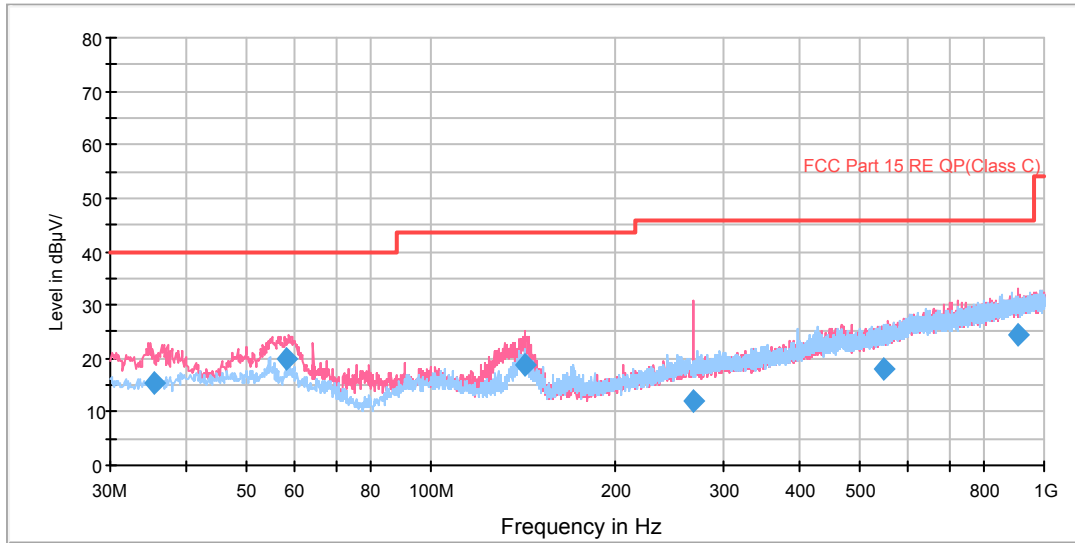

Radiates Emission from 30MHz to 1GHz

Frequency (MHz)	Quasi-Peak (dBuV/m)	Height (cm)	Polarization	Azimuth (deg)	Reading value (dBuV/m)	Correct Factor (dB)	Margin (dB)	Limit (dBuV/m)
35.328750	15.6	100.0	V	297.0	27.6	12.0	24.4	40.0
58.136250	20.1	125.0	V	210.0	32.7	12.6	19.9	40.0
142.037500	18.8	100.0	V	291.0	27.7	8.9	24.7	43.5
267.167500	12.1	100.0	V	240.0	26.6	14.5	33.9	46.0
547.577500	18.1	114.0	H	218.0	39.0	20.9	27.9	46.0
906.077500	24.4	114.0	V	324.0	50.1	25.7	21.6	46.0

- Remark: 1. Quasi-Peak = Reading value + Correction factor
 2. Correction Factor = Antenna factor+ Insertion loss(cable loss+amplifier gain)
 3. Margin = Limit – Quasi-Peak

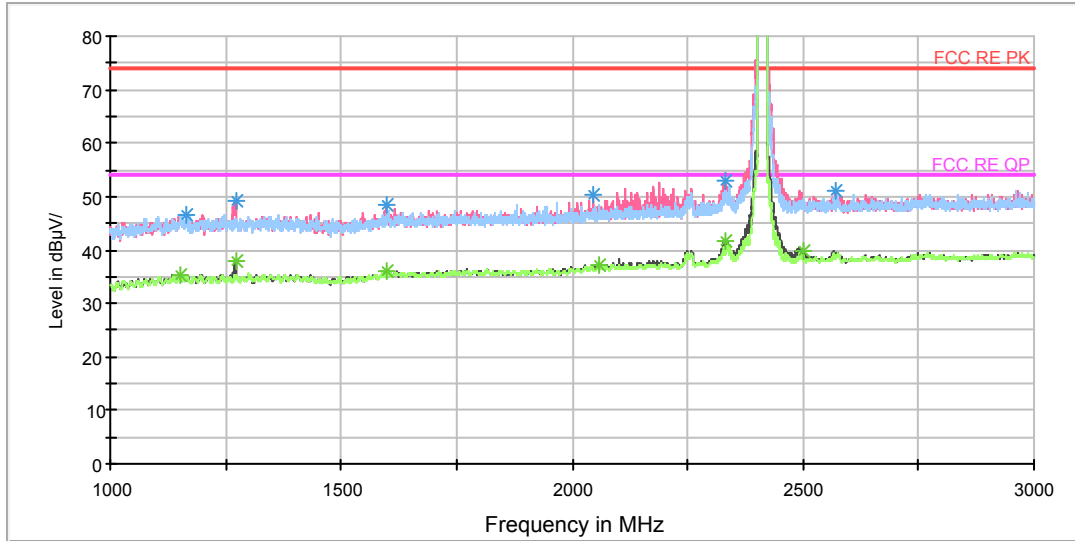

Note: The signal beyond the limit is carrier.

Radiates Emission from 1GHz to 3GHz

Frequency (MHz)	Peak (dBuV/m)	Height (cm)	Polarization	Azimuth (deg)	Reading value (dBuV/m)	Correct Factor (dB)	Margin (dB)	Limit (dBuV/m)
1166.500000	46.8	100.0	H	37.0	47.6	-0.8	27.2	74
1272.500000	49.0	100.0	V	0.0	49.3	-0.3	25.0	74
1597.000000	48.5	100.0	V	228.0	49.5	1.0	25.5	74
2044.000000	50.2	100.0	V	0.0	52.7	2.5	23.8	74
2332.500000	53.0	100.0	V	281.0	57.1	4.1	21.0	74
2568.500000	51.0	100.0	V	0.0	56.2	5.2	23.0	74

Remark: 1. Correction Factor = Antenna factor+ Insertion loss (cable loss + amplifier gain)

Frequency (MHz)	Average (dBuV/m)	Height (cm)	Polarization	Azimuth (deg)	Reading value (dBuV/m)	Correct Factor (dB)	Margin (dB)	Limit (dBuV/m)
1151.500000	35.5	100.0	V	312.0	36.3	-0.8	18.5	54
1271.500000	38.1	100.0	V	359.0	38.4	-0.3	15.9	54
1599.500000	36.2	100.0	V	0.0	37.2	1.0	17.8	54
2058.000000	37.3	100.0	V	0.0	39.9	2.6	16.7	54
2332.500000	41.8	100.0	V	281.0	45.9	4.1	12.2	54
2499.000000	39.9	100.0	V	356.0	44.9	5.0	14.1	54

Remark: 1. Correction Factor = Antenna factor+ Insertion loss (cable loss + amplifier gain)

RE 3G-18GHz PK+AV Class B

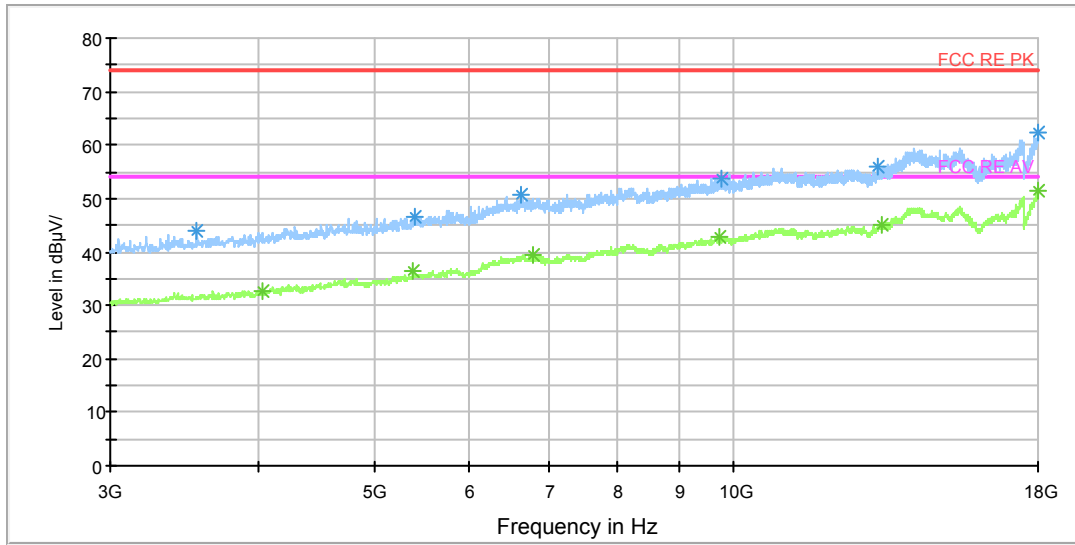

Radiates Emission from 3GHz to 18GHz

Frequency (MHz)	Peak (dBuV/m)	Height (cm)	Polarization	Azimuth (deg)	Reading value (dBuV/m)	Correct Factor (dB)	Margin (dB)	Limit (dBuV/m)
3549.000000	43.8	100.0	H	186.0	46.4	-2.6	30.2	74
5394.000000	46.4	100.0	H	1.0	47.4	1.0	27.6	74
6633.000000	50.8	100.0	H	7.0	55.9	5.1	23.2	74
9753.000000	53.7	100.0	H	1.0	64.7	11.0	20.3	74
13230.000000	55.9	100.0	V	75.0	73.5	17.6	18.1	74
17988.000000	62.3	100.0	H	206.0	88.0	25.7	11.7	74

Remark: 1. Correction Factor = Antenna factor+ Insertion loss (cable loss + amplifier gain)

Frequency (MHz)	Average (dBuV/m)	Height (cm)	Polarization	Azimuth (deg)	Reading value (dBuV/m)	Correct Factor (dB)	Margin (dB)	Limit (dBuV/m)
4029.000000	32.8	100.0	V	357.0	34.8	-2.0	21.2	54
5382.000000	36.4	100.0	H	225.0	37.3	0.9	17.6	54
6792.000000	39.5	100.0	V	144.0	44.5	5.0	14.5	54
9738.000000	42.8	100.0	H	346.0	53.9	11.1	11.2	54
13302.000000	45.1	100.0	H	70.0	62.8	17.7	8.9	54
17985.000000	51.3	100.0	H	1.0	77.0	25.7	2.7	54

Remark: 1. Correction Factor = Antenna factor+ Insertion loss (cable loss + amplifier gain)

RE 18-26.5GHz PK+AV

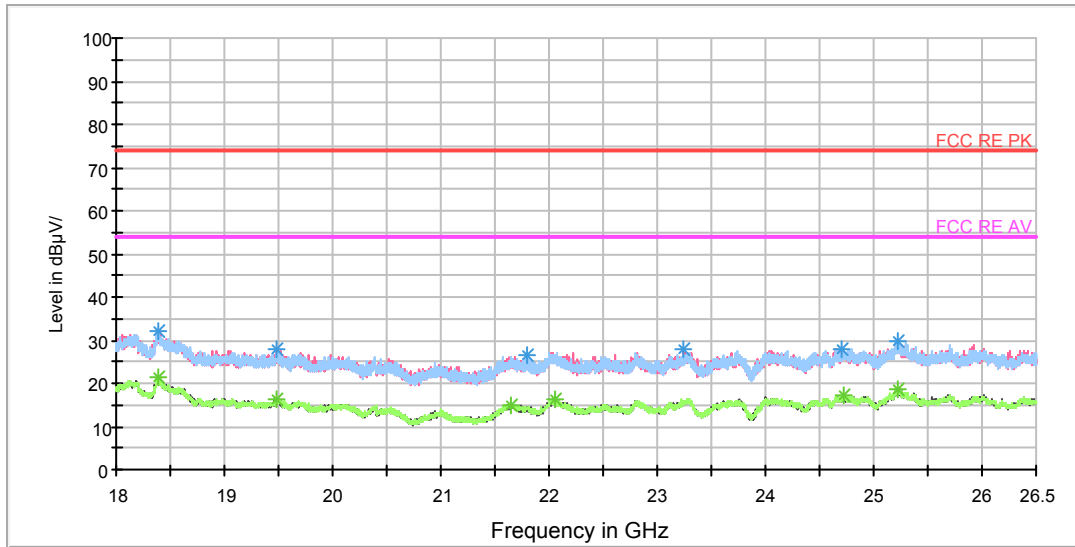

Radiates Emission from 18GHz to 26.5GHz

Frequency (MHz)	Peak (dBuV/m)	Polarization	Azimuth (deg)	Reading value (dBuV/m)	Correct Factor (dB)	Margin (dB)	Limit (dBuV/m)
18388.875000	32.1	H	0.0	37.0	-4.9	41.9	74
19486.437500	27.8	V	126.0	35.5	-7.7	46.2	74
21799.500000	26.4	H	27.0	35.1	-8.7	47.6	74
23236.000000	27.7	V	180.0	35.6	-7.9	46.3	74
24705.437500	28.1	V	40.0	34.8	-6.7	45.9	74
25221.812500	29.8	H	0.0	35.7	-5.9	44.2	74

Remark: 1. Correction Factor = Antenna factor+ Insertion loss (cable loss + amplifier gain)

Frequency (MHz)	Average (dBuV/m)	Polarization	Azimuth (deg)	Reading value (dBuV/m)	Correct Factor (dB)	Margin (dB)	Limit (dBuV/m)
18392.062500	21.2	H	0.0	26.1	-4.9	32.8	54
19490.687500	16.3	V	126.0	23.9	-7.6	37.7	54
21647.562500	15.0	H	43.0	24.2	-9.2	39.0	54
22049.187500	16.3	H	130.0	24.4	-8.1	37.7	54
24722.437500	17.0	H	59.0	23.2	-6.2	37.0	54
25229.250000	18.6	H	36.0	24.5	-5.9	35.4	54

Remark: 1. Correction Factor = Antenna factor+ Insertion loss (cable loss + amplifier gain)

802.11n (HT20) CH6

RE 0.03-1GHz QP Class B

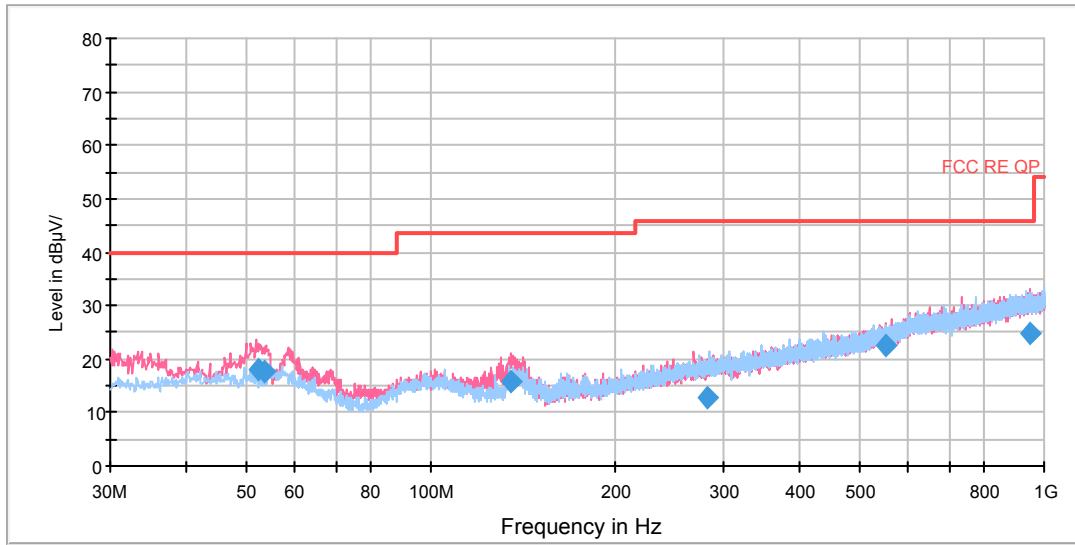

Radiates Emission from 30MHz to 1GHz

Frequency (MHz)	Quasi-Peak (dBuV/m)	Height (cm)	Polarization	Azimuth (deg)	Reading value (dBuV/m)	Correct Factor (dB)	Margin (dB)	Limit (dBuV/m)
52.345000	17.9	100.0	V	323.0	30.8	12.9	22.1	40.0
53.687500	17.6	100.0	V	196.0	30.4	12.8	22.4	40.0
135.280000	15.8	125.0	V	326.0	24.9	9.1	27.7	43.5
283.497500	12.8	125.0	H	126.0	27.8	15.0	33.2	46.0
550.000000	22.4	100.0	V	0.0	43.4	21.0	23.6	46.0
947.500000	24.9	100.0	V	355.0	50.9	26.0	21.1	46.0

- Remark: 1. Quasi-Peak = Reading value + Correction factor
 2. Correction Factor = Antenna factor+ Insertion loss(cable loss+amplifier gain)
 3. Margin = Limit – Quasi-Peak

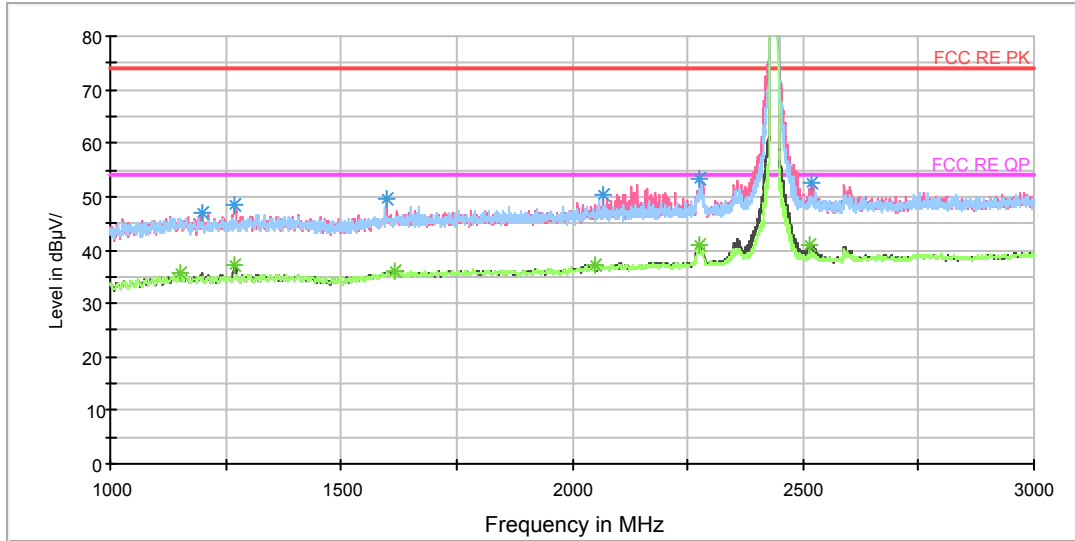

Note: The signal beyond the limit is carrier.
Radiates Emission from 1GHz to 3GHz

Frequency (MHz)	Peak (dBuV/m)	Height (cm)	Polarization	Azimuth (deg)	Reading value (dBuV/m)	Correct Factor (dB)	Margin (dB)	Limit (dBuV/m)
1199.500000	47.0	100.0	V	119.0	47.7	-0.7	27.0	74
1271.000000	48.5	100.0	V	0.0	48.8	-0.3	25.5	74
1597.500000	49.7	100.0	V	149.0	50.7	1.0	24.3	74
2068.000000	50.2	100.0	V	0.0	52.9	2.7	23.8	74
2276.000000	53.4	100.0	H	152.0	57.2	3.8	20.6	74
2518.000000	52.6	100.0	V	358.0	57.7	5.1	21.4	74

Remark: 1. Correction Factor = Antenna factor+ Insertion loss (cable loss + amplifier gain)

Frequency (MHz)	Average (dBuV/m)	Height (cm)	Polarization	Azimuth (deg)	Reading value (dBuV/m)	Correct Factor (dB)	Margin (dB)	Limit (dBuV/m)
1151.500000	35.7	100.0	H	0.0	36.5	-0.8	18.3	54
1269.500000	37.4	100.0	V	0.0	37.7	-0.3	16.6	54
1616.500000	35.9	100.0	H	0.0	37.0	1.1	18.1	54
2051.000000	37.2	100.0	V	351.0	39.8	2.6	16.8	54
2274.500000	41.0	100.0	H	152.0	44.8	3.8	13.0	54
2515.500000	40.9	100.0	V	0.0	46.0	5.1	13.1	54

Remark: 1. Correction Factor = Antenna factor+ Insertion loss (cable loss + amplifier gain)

RE 3G-18GHz PK+AV Class B

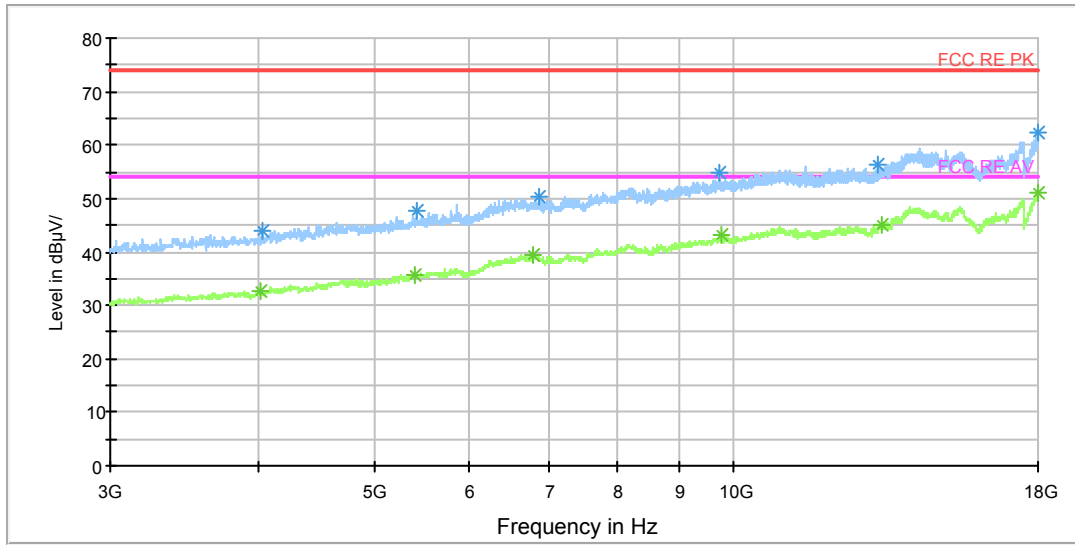

Radiates Emission from 3GHz to 18GHz

Frequency (MHz)	Peak (dBuV/m)	Height (cm)	Polarization	Azimuth (deg)	Reading value (dBuV/m)	Correct Factor (dB)	Margin (dB)	Limit (dBuV/m)
4029.000000	43.8	100.0	V	163.0	45.8	-2.0	30.2	74
5427.000000	47.6	100.0	V	357.0	48.7	1.1	26.4	74
6861.000000	50.4	100.0	V	0.0	55.4	5.0	23.6	74
9744.000000	55.0	100.0	H	9.0	66.1	11.1	19.0	74
13224.000000	56.2	100.0	V	307.0	73.7	17.5	17.8	74
17985.000000	62.3	100.0	H	52.0	88.0	25.7	11.7	74

Remark: 1. Correction Factor = Antenna factor+ Insertion loss (cable loss + amplifier gain)

Frequency (MHz)	Average (dBuV/m)	Height (cm)	Polarization	Azimuth (deg)	Reading value (dBuV/m)	Correct Factor (dB)	Margin (dB)	Limit (dBuV/m)
4008.000000	32.6	100.0	H	9.0	34.6	-2.0	21.4	54
5409.000000	35.8	100.0	H	62.0	36.9	1.1	18.2	54
6777.000000	39.6	100.0	V	297.0	44.6	5.0	14.4	54
9756.000000	43.1	100.0	H	13.0	54.1	11.0	10.9	54
13314.000000	45.1	100.0	H	13.0	62.8	17.7	8.9	54
17982.000000	51.3	100.0	V	326.0	76.9	25.6	2.7	54

Remark: 1. Correction Factor = Antenna factor+ Insertion loss (cable loss + amplifier gain)

RE 18-26.5GHz PK+AV

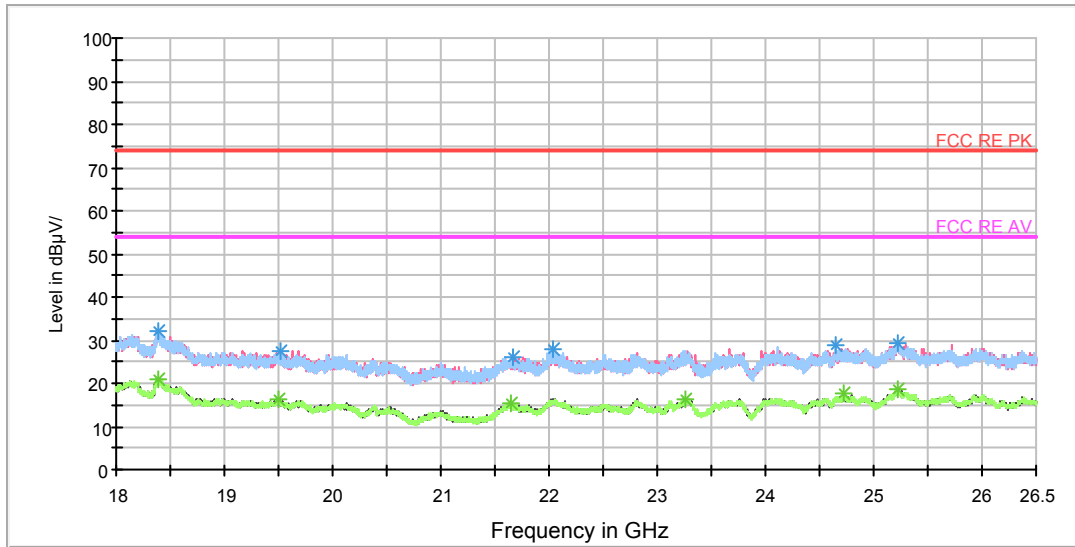

Radiates Emission from 18GHz to 26.5GHz

Frequency (MHz)	Peak (dBuV/m)	Polarization	Azimuth (deg)	Reading value (dBuV/m)	Correct Factor (dB)	Margin (dB)	Limit (dBuV/m)
18386.750000	32.1	V	130.0	36.9	-4.8	41.9	74
19509.812500	27.5	V	6.0	35.0	-7.5	46.5	74
21673.062500	25.9	H	51.0	35.2	-9.3	48.1	74
22031.125000	28.1	V	180.0	36.1	-8.0	45.9	74
24649.125000	28.7	H	0.0	35.7	-7.0	45.3	74
25225.000000	29.5	V	180.0	35.4	-5.9	44.5	74

Remark: 1. Correction Factor = Antenna factor+ Insertion loss (cable loss + amplifier gain)

Frequency (MHz)	Average (dBuV/m)	Polarization	Azimuth (deg)	Reading value (dBuV/m)	Correct Factor (dB)	Margin (dB)	Limit (dBuV/m)
18382.500000	21.1	V	169.0	25.9	-4.8	32.9	54
19491.750000	16.5	H	99.0	24.1	-7.6	37.5	54
21639.062500	15.3	V	153.0	24.4	-9.1	38.7	54
23264.687500	16.3	V	83.0	23.6	-7.3	37.7	54
24727.750000	17.4	V	83.0	23.6	-6.2	36.6	54
25222.875000	18.7	V	6.0	24.6	-5.9	35.3	54

Remark: 1. Correction Factor = Antenna factor+ Insertion loss (cable loss + amplifier gain)

802.11n (HT20) CH11

FCC RE 0.03-1GHz QP Class C

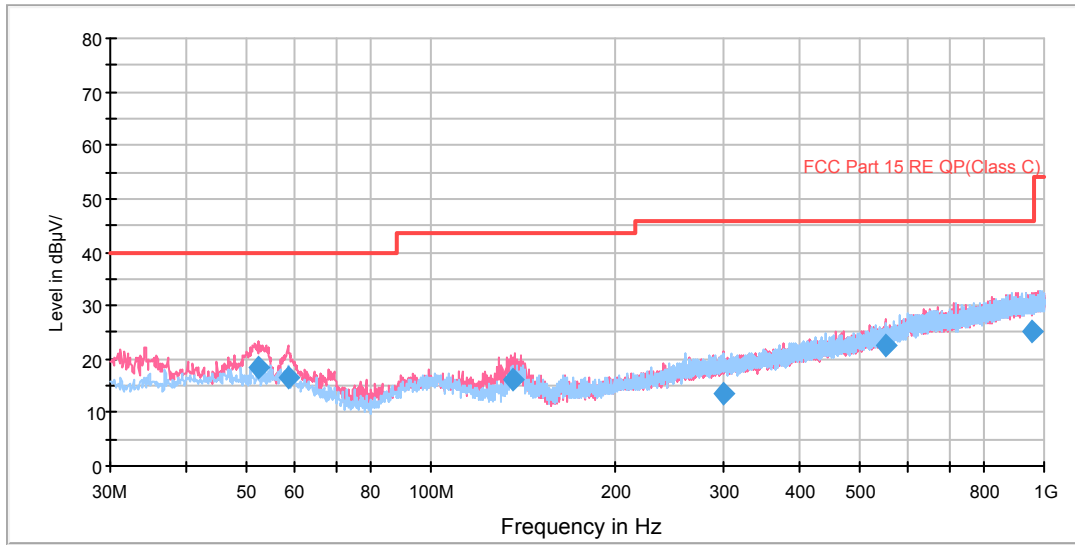

Radiates Emission from 30MHz to 1GHz

Frequency (MHz)	Quasi-Peak (dBuV/m)	Height (cm)	Polarization	Azimuth (deg)	Reading value (dBuV/m)	Correct Factor (dB)	Margin (dB)	Limit (dBuV/m)
52.390000	18.4	100.0	V	268.0	31.3	12.9	21.6	40.0
58.573750	16.6	114.0	V	26.0	29.2	12.6	23.4	40.0
136.342500	16.1	125.0	V	338.0	25.2	9.1	27.4	43.5
299.978750	13.5	125.0	V	356.0	29.0	15.5	32.5	46.0
550.001250	22.4	100.0	V	0.0	43.4	21.0	23.6	46.0
956.750000	25.0	125.0	V	336.0	51.1	26.1	21.0	46.0

- Remark: 1. Quasi-Peak = Reading value + Correction factor
 2. Correction Factor = Antenna factor+ Insertion loss(cable loss+amplifier gain)
 3. Margin = Limit – Quasi-Peak

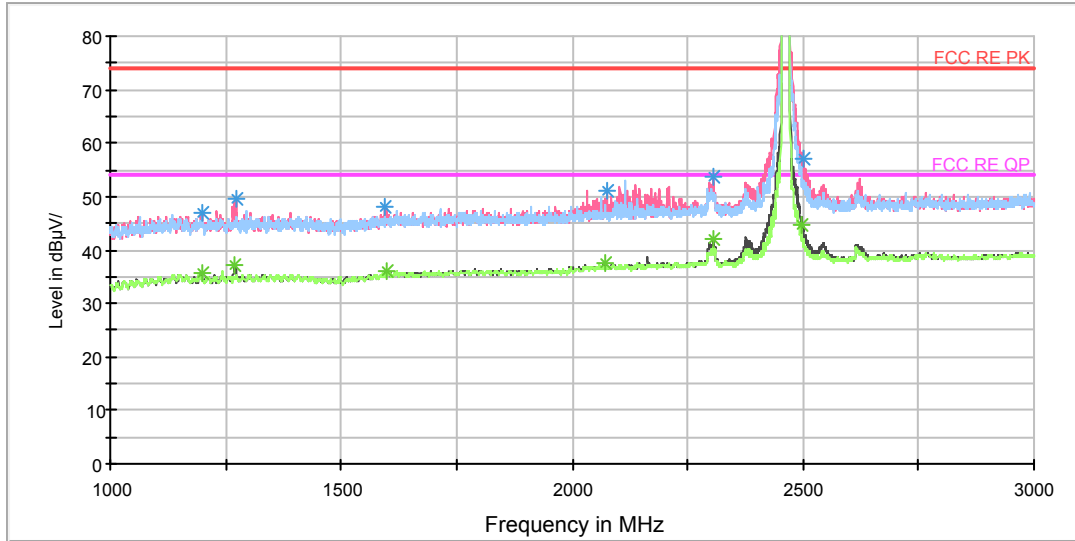

Note: The signal beyond the limit is carrier.

Radiates Emission from 1GHz to 3GHz

Frequency (MHz)	Peak (dBuV/m)	Height (cm)	Polarization	Azimuth (deg)	Reading value (dBuV/m)	Correct Factor (dB)	Margin (dB)	Limit (dBuV/m)
1198.000000	47.1	100.0	V	359.0	47.8	-0.7	26.9	74
1272.000000	49.5	100.0	V	0.0	49.8	-0.3	24.5	74
1595.000000	48.1	100.0	V	218.0	49.1	1.0	25.9	74
2076.000000	51.2	100.0	V	0.0	53.9	2.7	22.8	74
2306.500000	53.7	100.0	V	0.0	57.7	4.0	20.3	74
2501.500000	57.2	100.0	V	0.0	62.2	5.0	16.8	74

Remark: 1. Correction Factor = Antenna factor+ Insertion loss (cable loss + amplifier gain)

Frequency (MHz)	Average (dBuV/m)	Height (cm)	Polarization	Azimuth (deg)	Reading value (dBuV/m)	Correct Factor (dB)	Margin (dB)	Limit (dBuV/m)
1199.000000	35.8	100.0	V	359.0	36.5	-0.7	18.2	54
1271.000000	37.2	100.0	V	0.0	37.5	-0.3	16.8	54
1599.000000	36.0	100.0	V	326.0	37.0	1.0	18.0	54
2070.500000	37.4	100.0	V	311.0	40.1	2.7	16.6	54
2307.500000	42.0	100.0	V	0.0	46.0	4.0	12.0	54
2498.500000	44.7	100.0	V	357.0	49.7	5.0	9.3	54

Remark: 1. Correction Factor = Antenna factor+ Insertion loss (cable loss + amplifier gain)

RE 3G-18GHz PK+AV Class B

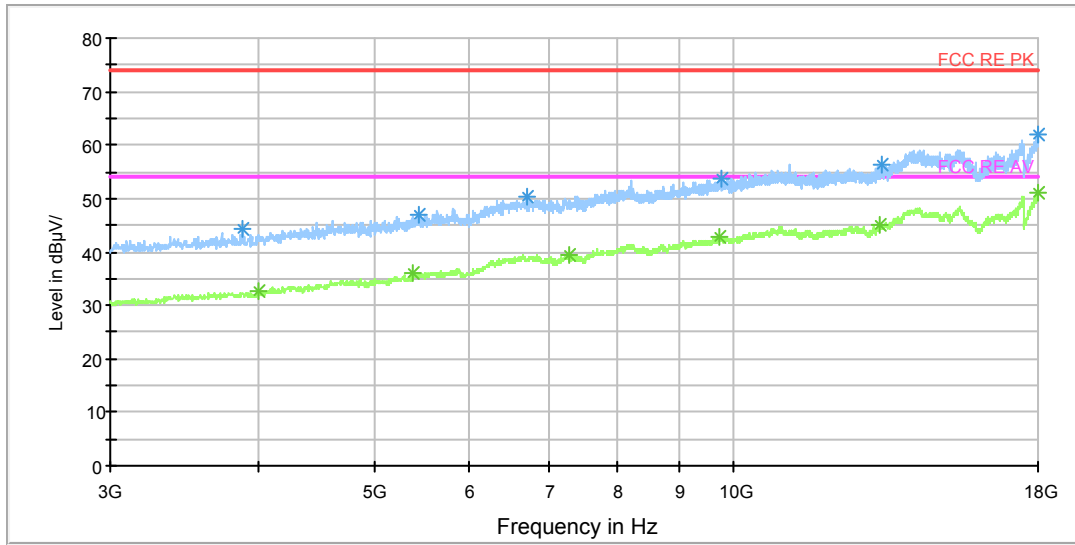

Radiates Emission from 3GHz to 18GHz

Frequency (MHz)	Peak (dBuV/m)	Height (cm)	Polarization	Azimuth (deg)	Reading value (dBuV/m)	Correct Factor (dB)	Margin (dB)	Limit (dBuV/m)
3879.000000	44.1	100.0	H	2.0	46.3	-2.2	29.9	74
5439.000000	47.1	100.0	V	70.0	48.3	1.2	26.9	74
6699.000000	50.4	100.0	H	61.0	55.4	5.0	23.6	74
9762.000000	53.7	100.0	H	99.0	64.7	11.0	20.3	74
13296.000000	56.5	100.0	H	61.0	74.2	17.7	17.5	74
17979.000000	62.0	100.0	V	332.0	87.6	25.6	12.0	74

Remark: 1. Correction Factor = Antenna factor+ Insertion loss (cable loss + amplifier gain)

Frequency (MHz)	Average (dBuV/m)	Height (cm)	Polarization	Azimuth (deg)	Reading value (dBuV/m)	Correct Factor (dB)	Margin (dB)	Limit (dBuV/m)
4002.000000	32.8	100.0	V	0.0	34.9	-2.1	21.2	54
5382.000000	36.1	100.0	V	358.0	37.0	0.9	17.9	54
7290.000000	39.6	100.0	V	255.0	45.2	5.6	14.4	54
9744.000000	42.9	100.0	V	0.0	54.0	11.1	11.1	54
13251.000000	45.0	100.0	H	0.0	62.6	17.6	9.0	54
17979.000000	51.2	100.0	H	42.0	76.8	25.6	2.8	54

Remark: 1. Correction Factor = Antenna factor+ Insertion loss (cable loss + amplifier gain)

RE 18-26.5GHz PK+AV

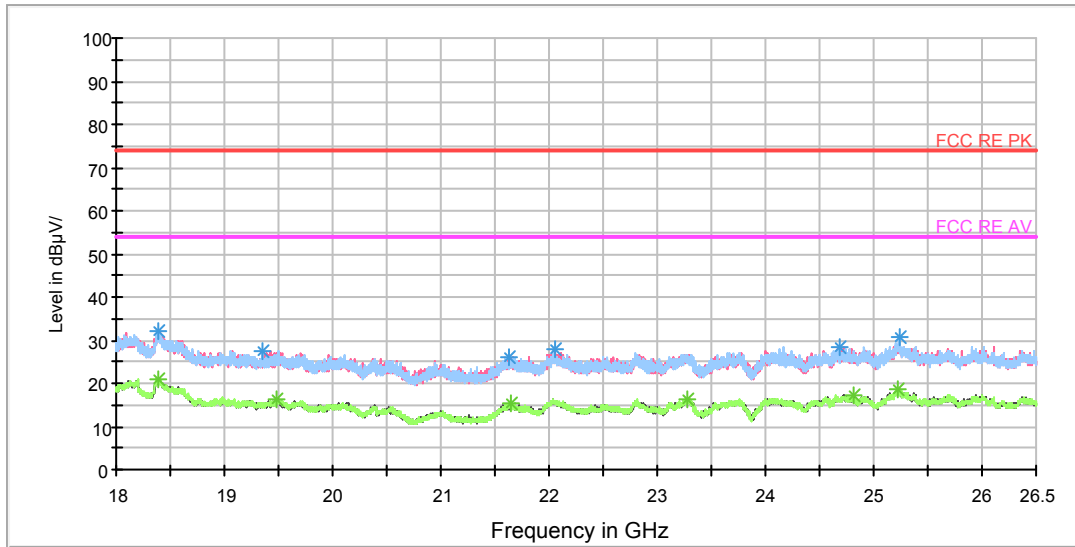

Radiates Emission from 18GHz to 26.5GHz

Frequency (MHz)	Peak (dBuV/m)	Polarization	Azimuth (deg)	Reading value (dBuV/m)	Correct Factor (dB)	Margin (dB)	Limit (dBuV/m)
18395.250000	32.1	H	0.0	37.0	-4.9	41.9	74
19358.937500	27.3	H	14.0	35.0	-7.7	46.7	74
21635.875000	26.2	V	64.0	35.3	-9.1	47.8	74
22048.125000	27.7	V	180.0	35.8	-8.1	46.3	74
24690.562500	28.4	H	67.0	35.3	-6.9	45.6	74
25232.437500	30.6	H	0.0	36.5	-5.9	43.4	74

Remark: 1. Correction Factor = Antenna factor+ Insertion loss (cable loss + amplifier gain)

Frequency (MHz)	Average (dBuV/m)	Polarization	Azimuth (deg)	Reading value (dBuV/m)	Correct Factor (dB)	Margin (dB)	Limit (dBuV/m)
18396.312500	21.1	V	129.0	26.0	-4.9	32.9	54
19488.562500	16.3	V	89.0	24.0	-7.7	37.7	54
21653.937500	15.2	V	175.0	24.4	-9.2	38.8	54
23275.312500	16.3	V	180.0	23.5	-7.2	37.7	54
24807.437500	17.4	V	153.0	24.1	-6.7	36.6	54
25223.937500	18.7	V	180.0	24.6	-5.9	35.3	54

Remark: 1. Correction Factor = Antenna factor+ Insertion loss (cable loss + amplifier gain)

5.8. Conducted Emission

Ambient condition

Temperature	Relative humidity	Pressure
23°C ~25°C	45%~50%	101.5kPa

Methods of Measurement

The EUT is placed on a non-metallic table of 80cm height above the horizontal metal reference ground plane. During the test, the EUT was operating in its typical mode. The test method is according to ANSI C63.10-2013. Connect the AC power line of the EUT to the L.I.S.N. Use EMI receiver to detect the average and Quasi-peak value. RBW is set to 9 kHz, VBW is set to 30kHz. The measurement result should include both L line and N line.

The test is in transmitting mode.

Test Setup

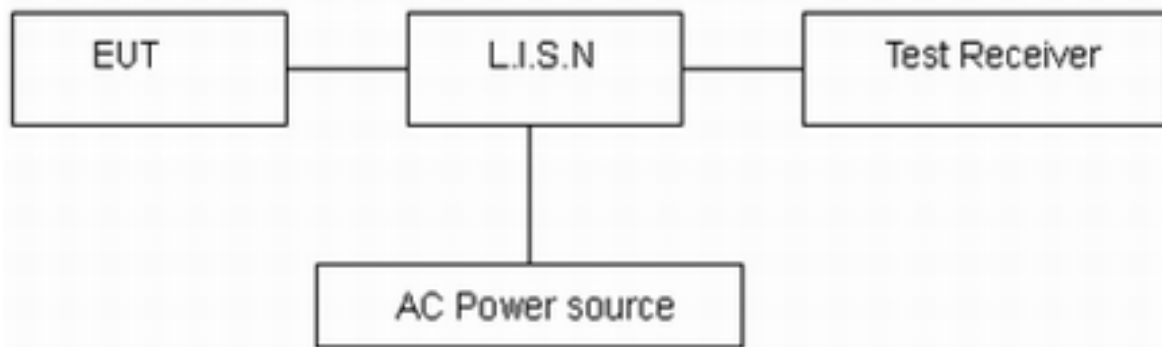

Note: AC Power source is used to change the voltage 110V/60Hz.

Limits

Frequency (MHz)	Conducted Limits(dBμV)	
	Quasi-peak	Average
0.15 - 0.5	66 to 56 *	56 to 46*
0.5 - 5	56	46
5 - 30	60	50

*: Decreases with the logarithm of the frequency.

Measurement Uncertainty

The assessed measurement uncertainty to ensure 95% confidence level for the normal distribution is with the coverage factor $k = 1.96$, $U = 2.69$ dB.



Test Results:

Following plots, Blue trace uses the peak detection, Green trace uses the average detection.

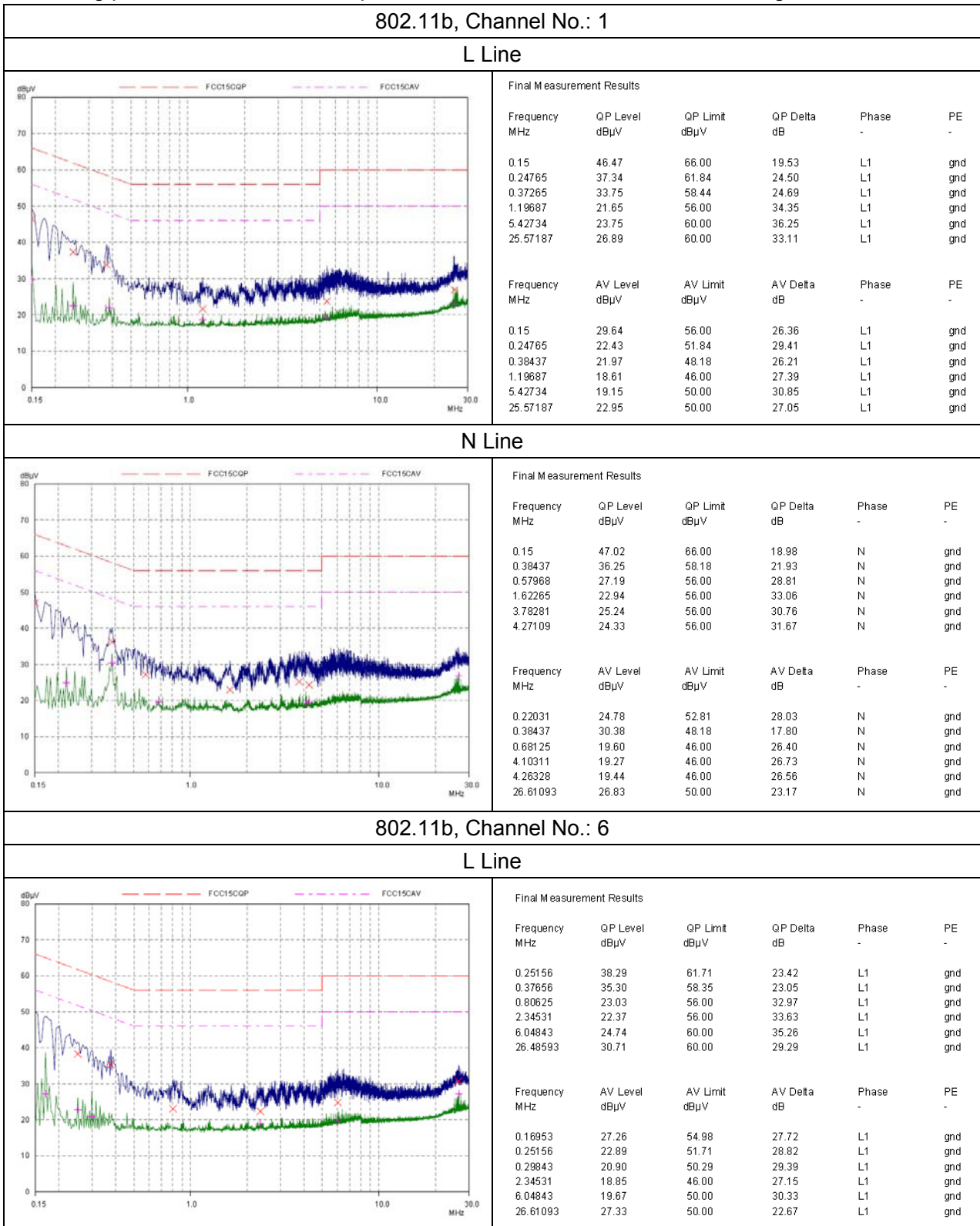

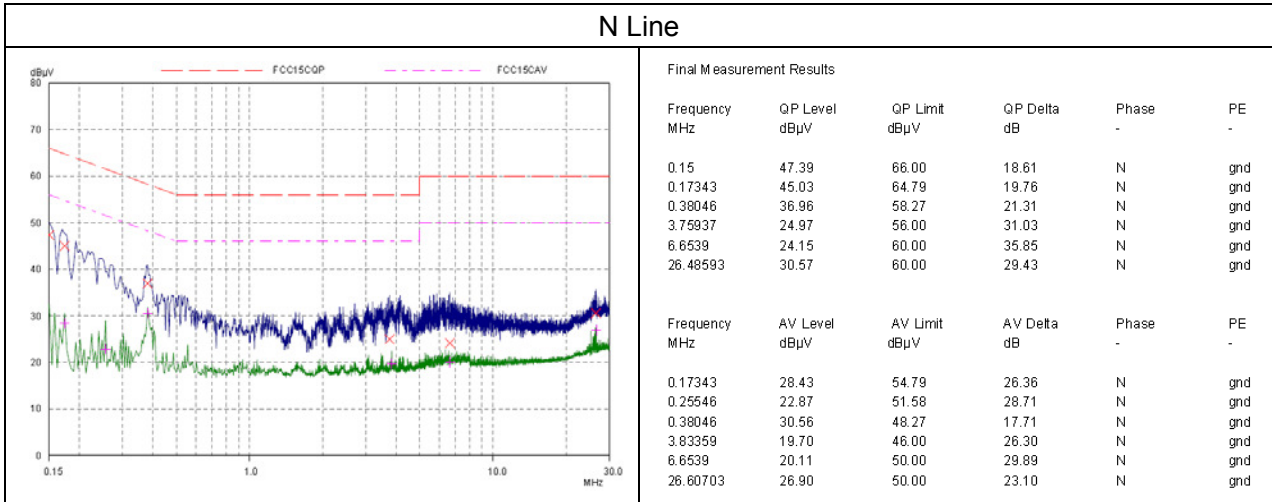

802.11b, Channel No.: 11

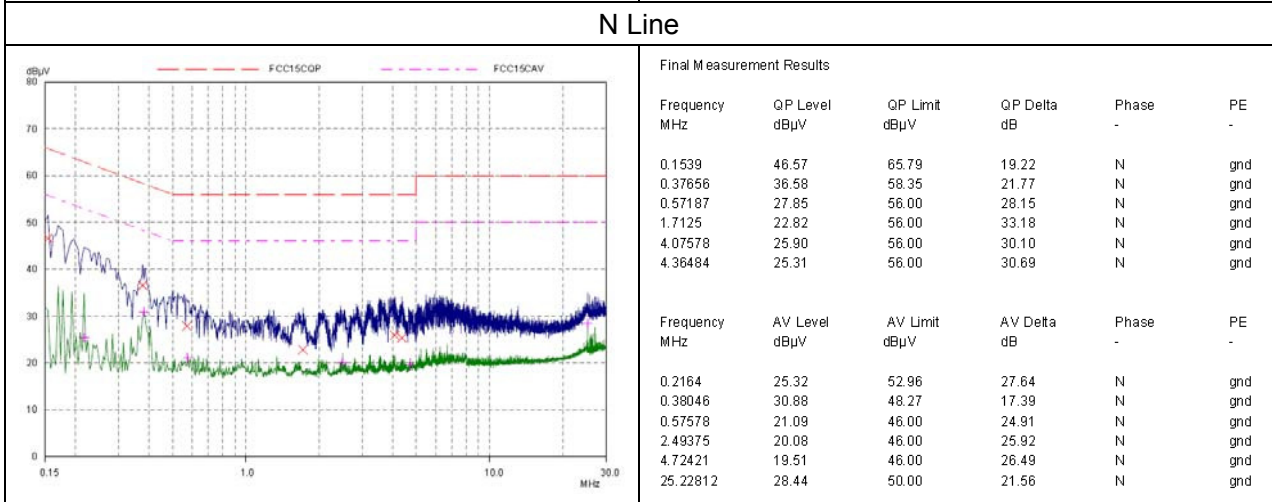
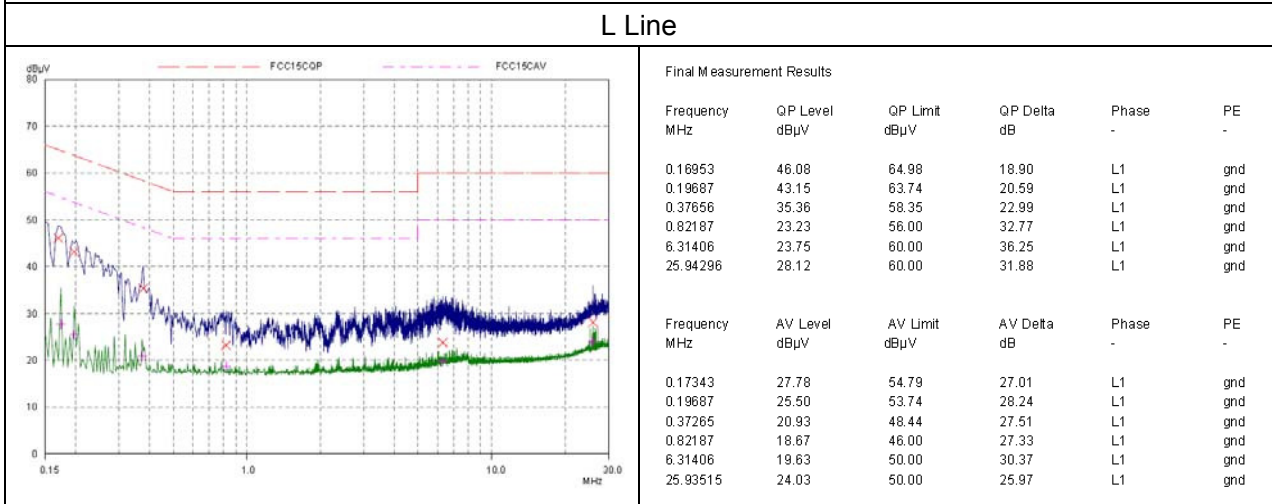



802.11g, Channel No.: 1

L Line

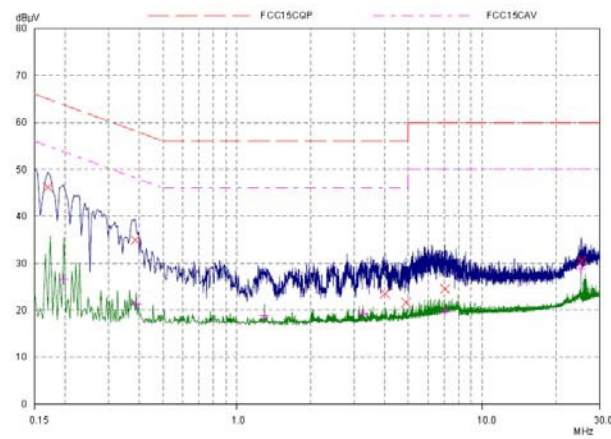

Final Measurement Results

Frequency MHz	QP Level dBµV	QP Limit dBµV	QP Delta dB	Phase	PE
0.16953	46.16	64.98	18.82	L1	gnd
0.38437	34.93	58.18	23.25	L1	gnd
4.01328	23.51	56.00	32.49	L1	gnd
4.88437	21.65	56.00	34.35	L1	gnd
7.04453	24.57	60.00	35.43	L1	gnd
25.38046	30.56	60.00	29.44	L1	gnd

Frequency MHz	AV Level dBµV	AV Limit dBµV	AV Delta dB	Phase	PE
0.19687	26.53	53.74	27.21	L1	gnd
0.38828	21.23	48.10	26.87	L1	gnd
1.29453	18.87	46.00	27.13	L1	gnd
3.25546	19.26	46.00	26.74	L1	gnd
7.04453	19.98	50.00	30.02	L1	gnd
25.22812	28.79	50.00	21.21	L1	gnd

N Line

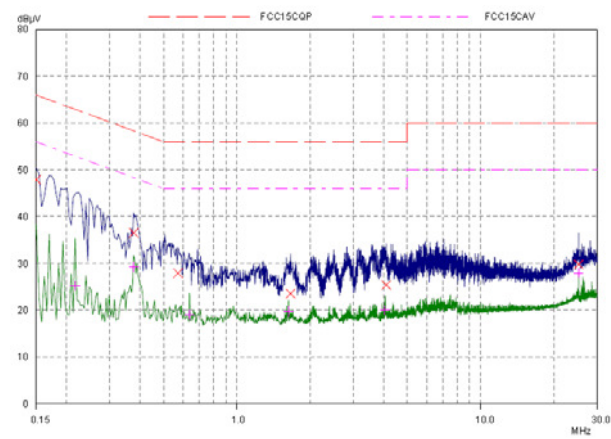

Final Measurement Results

Frequency MHz	QP Level dBµV	QP Limit dBµV	QP Delta dB	Phase	PE
0.15	47.93	66.00	18.07	N	gnd
0.37656	36.56	58.35	21.79	N	gnd
0.57187	27.93	56.00	28.07	N	gnd
1.65781	23.54	56.00	32.46	N	gnd
4.09921	25.37	56.00	30.63	N	gnd
25.22812	29.82	60.00	30.18	N	gnd

Frequency MHz	AV Level dBµV	AV Limit dBµV	AV Delta dB	Phase	PE
0.2164	25.24	52.96	27.72	N	gnd
0.37656	29.34	48.35	19.01	N	gnd
0.63828	19.04	46.00	26.96	N	gnd
1.62656	19.74	46.00	26.26	N	gnd
4.04453	20.03	46.00	25.97	N	gnd
25.22812	28.01	50.00	21.99	N	gnd

802.11g, Channel No.: 6

L Line

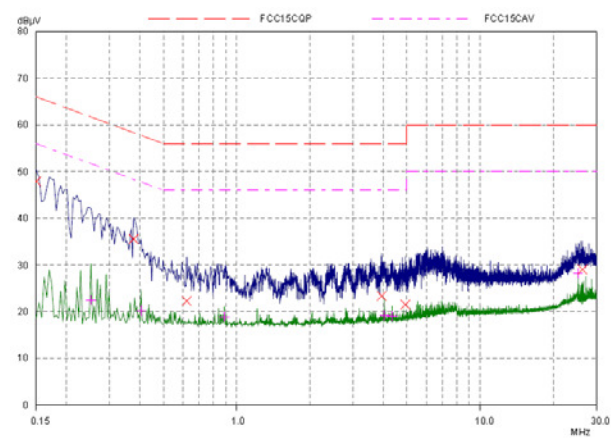

Final Measurement Results

Frequency MHz	QP Level dBµV	QP Limit dBµV	QP Delta dB	Phase	PE
0.15	47.89	66.00	18.11	L1	gnd
0.37656	35.56	58.35	22.79	L1	gnd
0.62265	22.26	56.00	33.74	L1	gnd
3.93515	23.34	56.00	32.66	L1	gnd
4.92734	21.49	56.00	34.51	L1	gnd
26.31015	29.01	60.00	30.99	L1	gnd

Frequency MHz	AV Level dBµV	AV Limit dBµV	AV Delta dB	Phase	PE
0.25156	22.54	51.71	29.17	L1	gnd
0.4039	20.21	47.77	27.56	L1	gnd
0.88828	18.96	46.00	27.04	L1	gnd
4.04061	19.24	46.00	26.76	L1	gnd
4.34531	19.05	46.00	26.95	L1	gnd
25.22812	28.26	50.00	21.74	L1	gnd

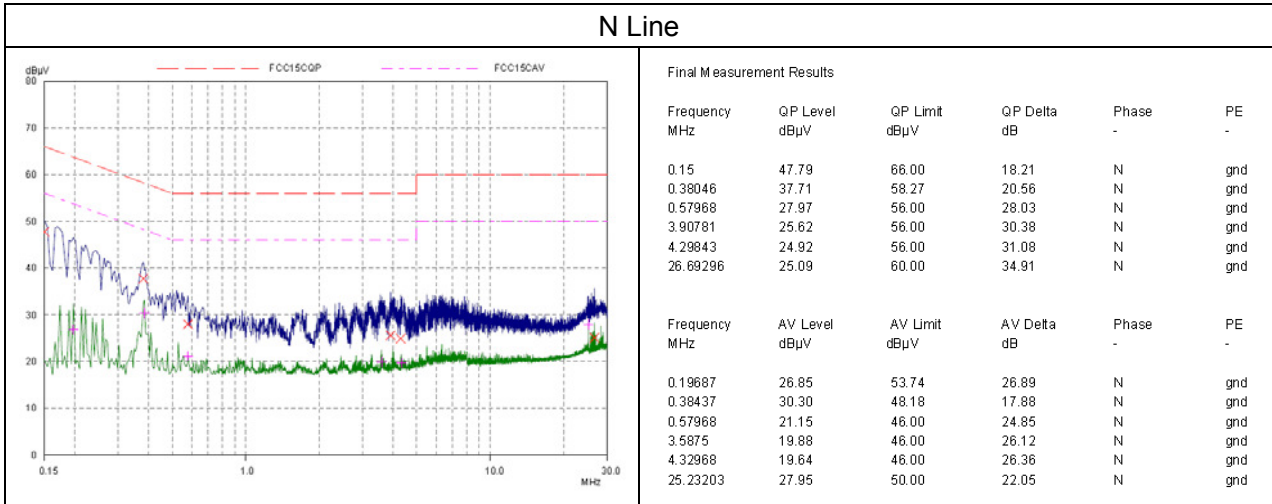

802.11g, Channel No.: 11

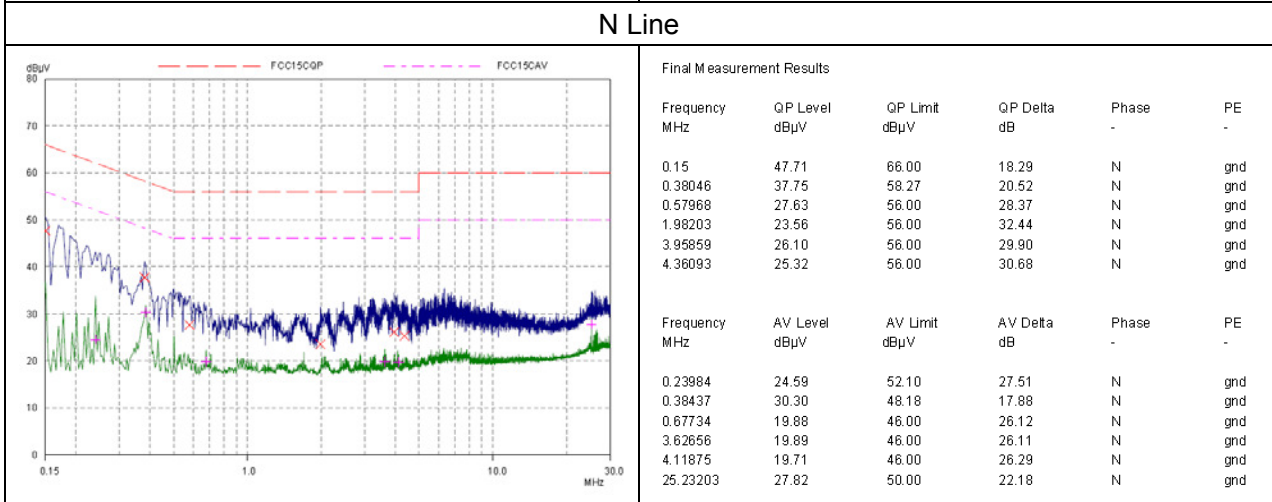
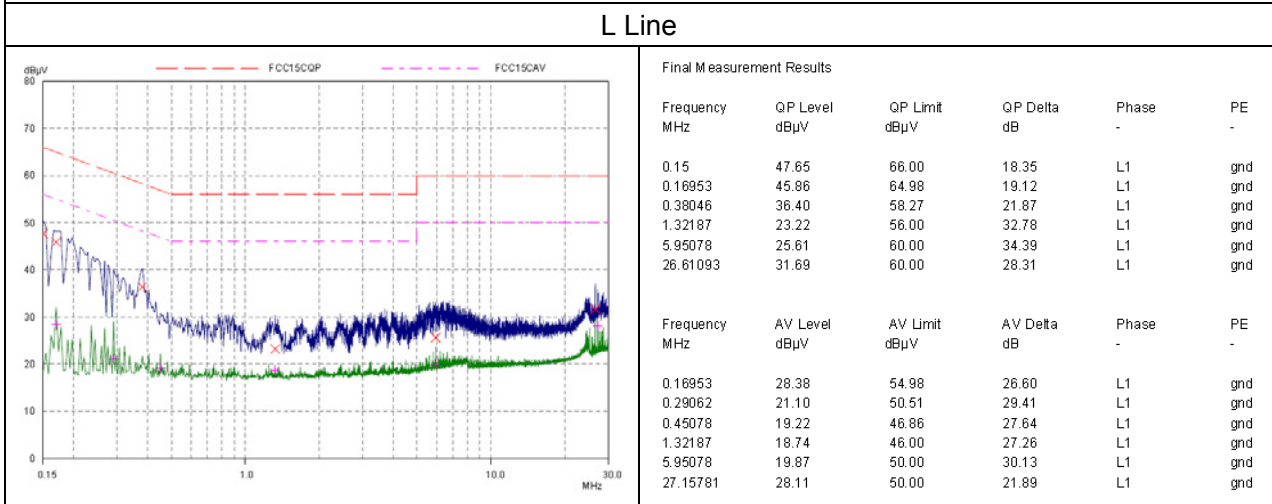



802.11n(HT20), Channel No.: 1

L Line

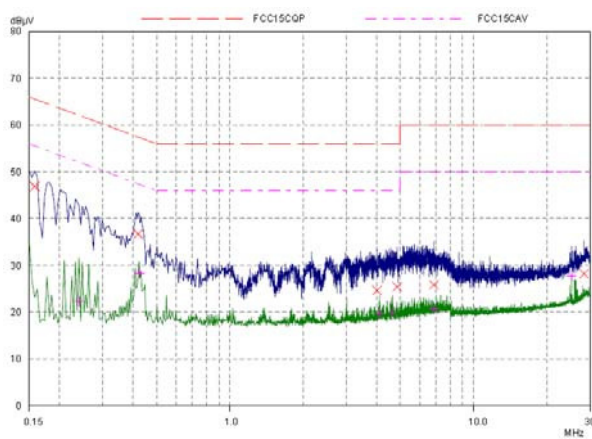

Final Measurement Results

Frequency MHz	QP Level dBµV	QP Limit dBµV	QP Delta dB	Phase	PE
0.15781	46.90	65.58	18.68	L1	gnd
0.41953	36.69	57.46	20.77	L1	gnd
4.01328	24.66	56.00	31.34	L1	gnd
4.85312	25.42	56.00	30.58	L1	gnd
6.86875	25.85	60.00	34.15	L1	gnd
28.36093	28.21	60.00	31.79	L1	gnd

Frequency MHz	AV Level dBµV	AV Limit dBµV	AV Delta dB	Phase	PE
0.23984	22.28	52.10	29.82	L1	gnd
0.42343	28.25	47.38	19.13	L1	gnd
4.10703	19.71	46.00	26.29	L1	gnd
4.64218	19.98	46.00	26.02	L1	gnd
6.86875	20.75	50.00	29.25	L1	gnd
25.22812	27.76	50.00	22.24	L1	gnd

N Line

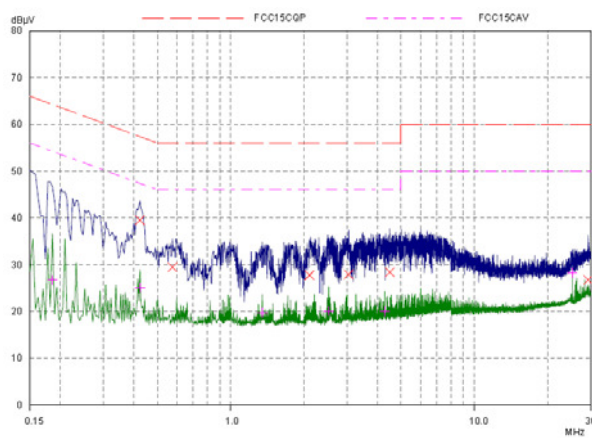

Final Measurement Results

Frequency MHz	QP Level dBµV	QP Limit dBµV	QP Delta dB	Phase	PE
0.42343	39.50	57.38	17.88	N	gnd
0.57578	29.45	56.00	26.55	N	gnd
2.10312	27.76	56.00	28.24	N	gnd
3.04453	27.92	56.00	28.08	N	gnd
4.48984	28.41	56.00	27.59	N	gnd
29.26328	26.75	60.00	33.25	N	gnd

Frequency MHz	AV Level dBµV	AV Limit dBµV	AV Delta dB	Phase	PE
0.18515	26.68	54.25	27.57	N	gnd
0.42343	25.10	47.38	22.28	N	gnd
1.34531	19.71	46.00	26.29	N	gnd
2.52109	20.15	46.00	25.85	N	gnd
4.2789	20.04	46.00	25.96	N	gnd
25.22812	28.32	50.00	21.68	N	gnd

802.11n(HT20), Channel No.: 6

L Line

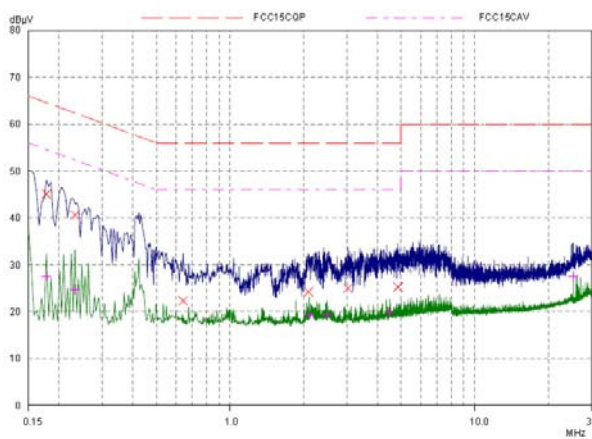

Final Measurement Results

Frequency MHz	QP Level dBµV	QP Limit dBµV	QP Delta dB	Phase	PE
0.17734	45.10	64.61	19.51	L1	gnd
0.23203	40.64	62.38	21.74	L1	gnd
0.64218	22.34	56.00	33.66	L1	gnd
2.0875	24.24	56.00	31.76	L1	gnd
3.0289	25.00	56.00	31.00	L1	gnd
4.84531	25.27	56.00	30.73	L1	gnd

Frequency MHz	AV Level dBµV	AV Limit dBµV	AV Delta dB	Phase	PE
0.17734	27.66	54.61	26.95	L1	gnd
0.23203	24.68	52.38	27.70	L1	gnd
2.10312	19.39	46.00	26.61	L1	gnd
2.48593	19.30	46.00	26.70	L1	gnd
4.49375	19.94	46.00	26.06	L1	gnd
25.22812	27.63	50.00	22.37	L1	gnd

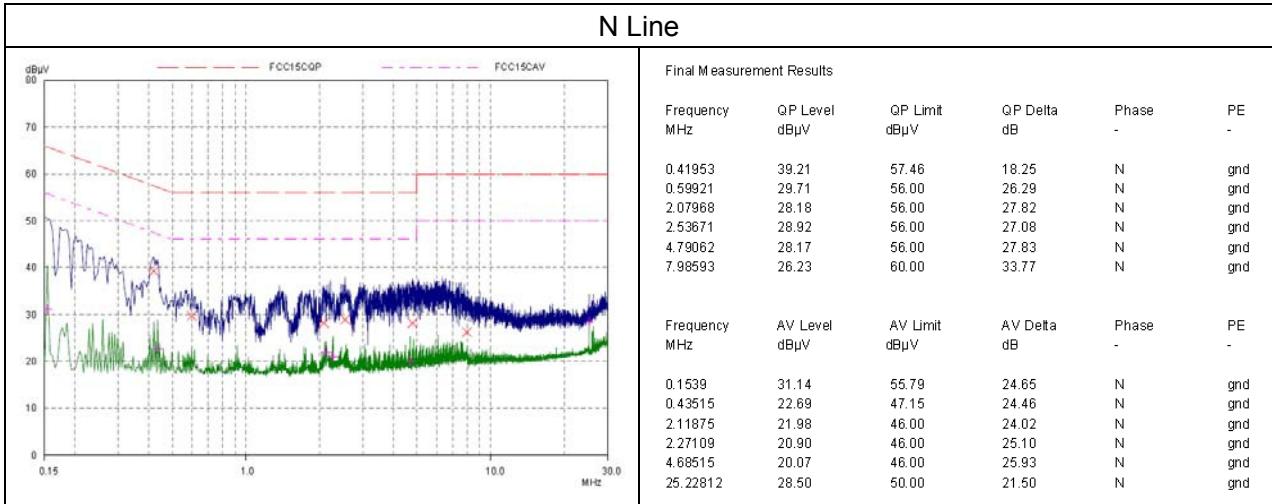

802.11n(HT20), Channel No.: 11

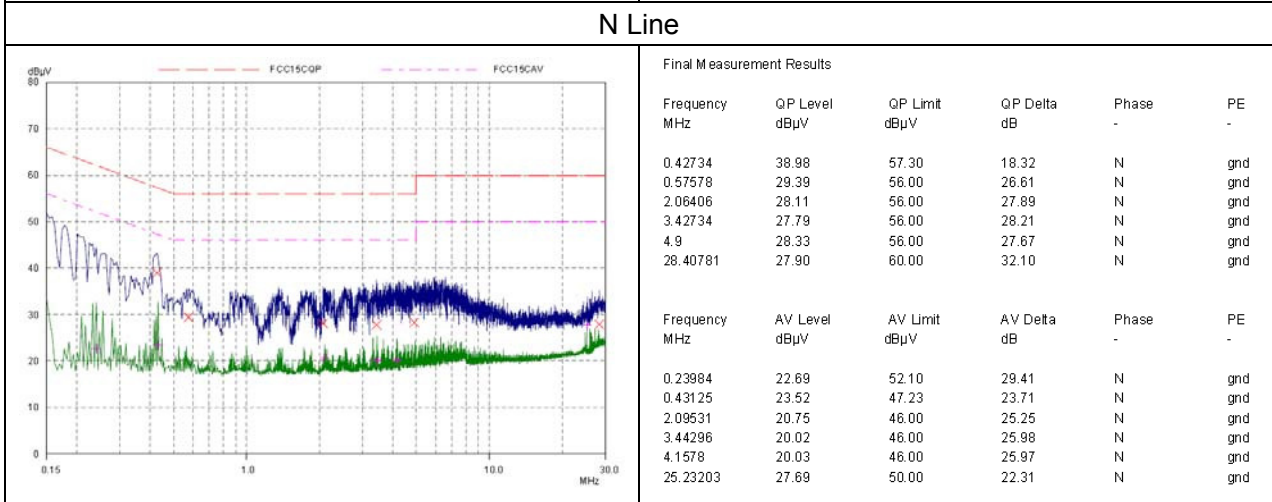
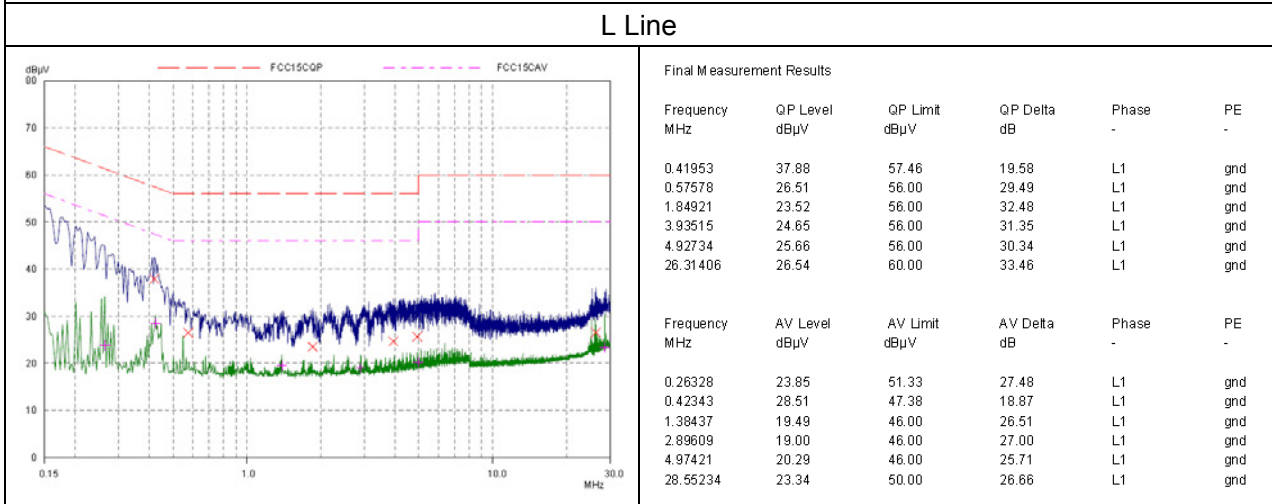



6. Main Test Instruments

Name	Type	Manufacturer	Serial Number	Calibration Date	Expiration Time
EMI Test Receiver	ESCI	R&S	100948	2015-05-22	2016-05-21
Loop Antenna	FMZB1519	SCHWARZBECK	1519-047	2014-02-29	2017-02-28
TRILOG Broadband Antenna	VULB 9163	Schwarzbeck	9163-201	2014-12-06	2017-12-05
Double Ridged Waveguide Horn Antenna	HF907	R&S	100126	2014-12-06	2017-12-05
Standard Gain Horn	3160-09	ETS-Lindgren	00102644	2015-01-30	2018-01-29
EMI Test Receiver	ESCS30	R&S	100138	2015-12-17	2016-12-16
LISN	ENV216	R&S	101171	2013-12-18	2016-12-17
Spectrum Analyzer	E4445A	Agilent	MY46181146	2015-05-22	2016-05-21
Spectrum Analyzer	N9010A	Agilent	MY47191109	2015-05-22	2016-05-21
MOB COMMS DC SUPPLY	66319D	Agilent	MY43004105	2015-05-22	2016-05-21
Peak Power Meter	U2021XA	Keysight	MY78520134	2015-05-19	2016-05-18
Spectrum Analyzer	FSV30	R&S	100815	2015-12-17	2016-12-16
RF Cable	SMA 15cm	Agilent	0001	2016-04-07	2016-07-06

*****END OF REPORT *****

ANNEX A: EUT Appearance and Test Setup

A.1 EUT Appearance



Front Side

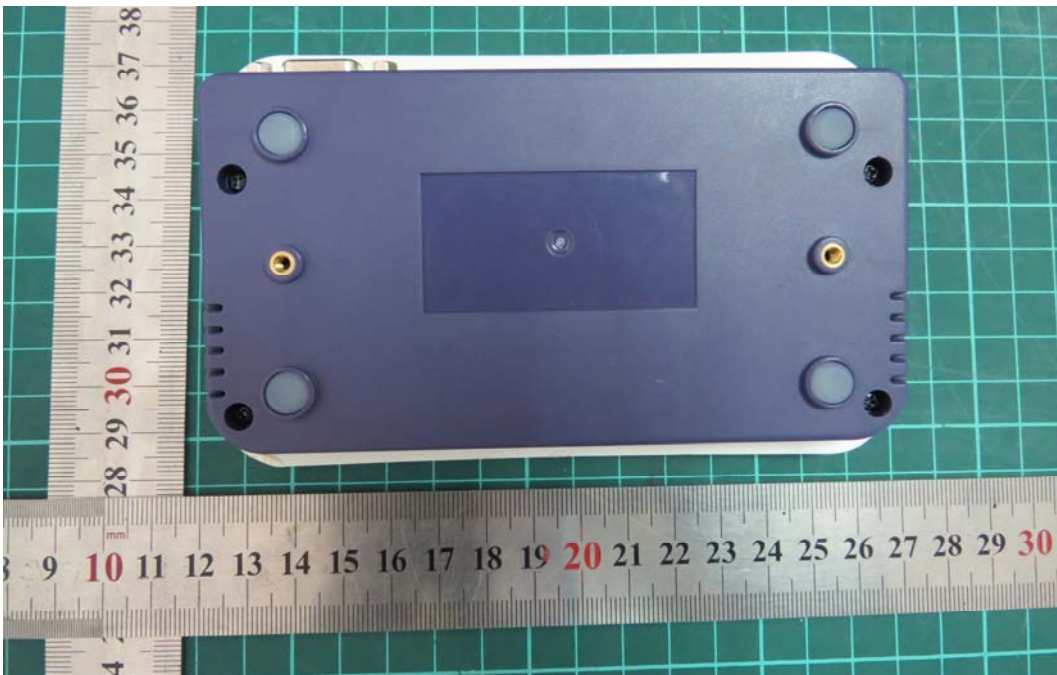

Back Side

a: EUT

Picture 1 EUT

A.2 Test Setup



30M Hz-1GHz

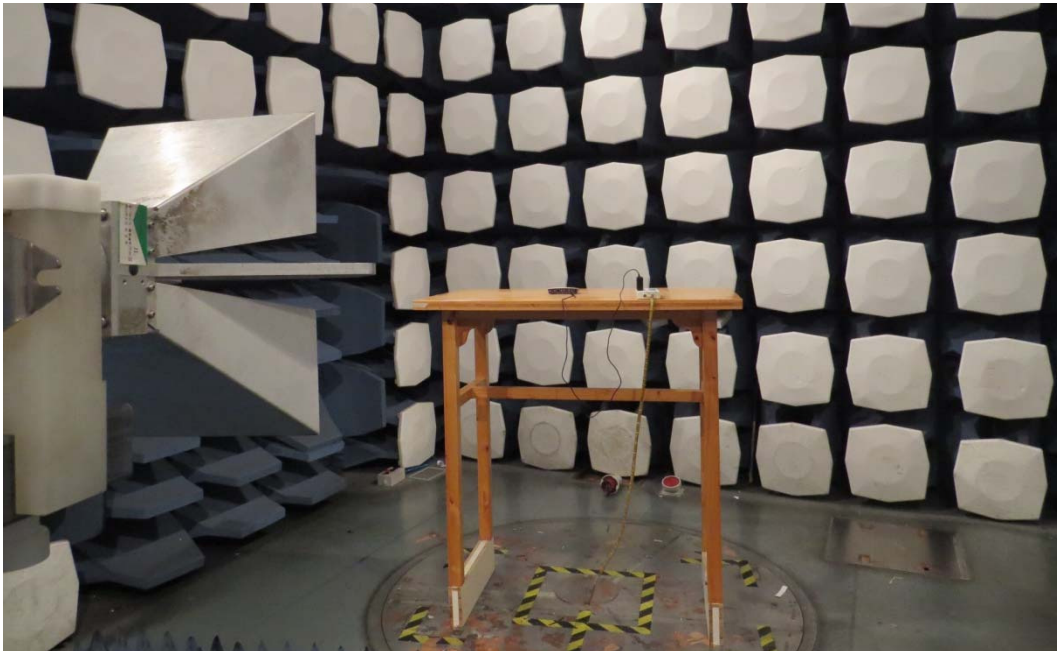

Above 1GHz

Picture 2 Radiated Emission Test Setup

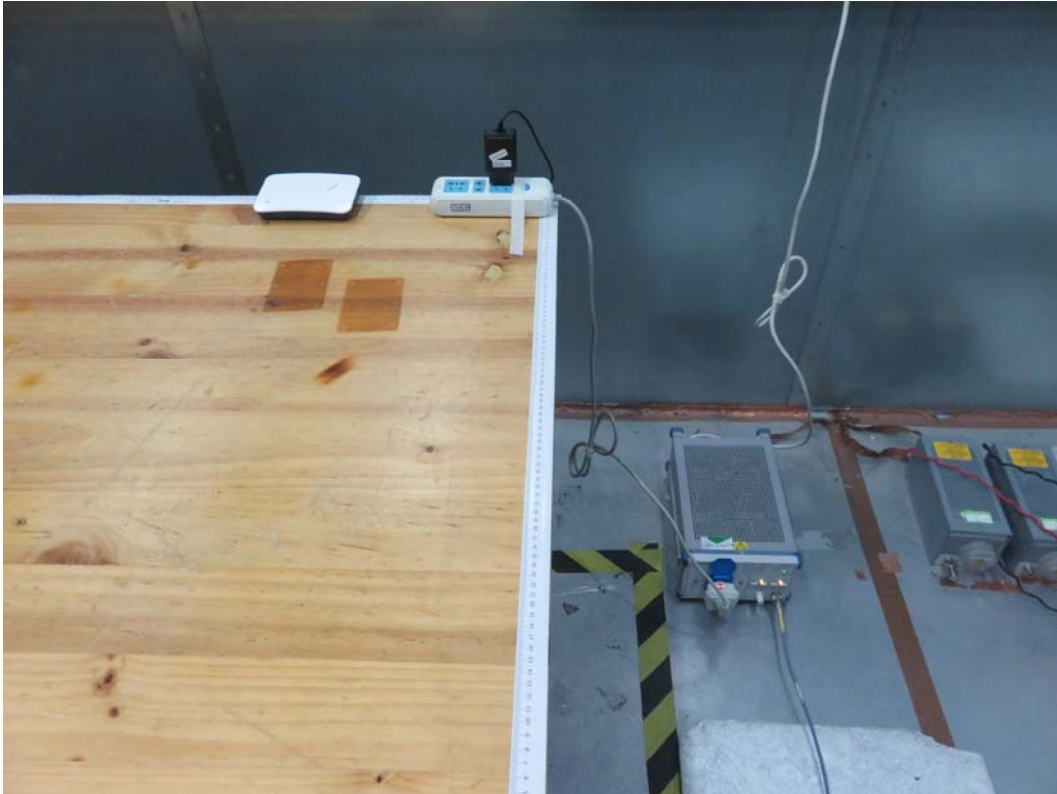

Picture 3 Conducted Emission Test Setup