

FCC Test Report

Report No.: RFBHLU-WTW-P23020721

FCC ID: WQJ-ID80149014

Test Model: ID-80149014-001

Series Model: ID-80149014-00X (X=1~9) (refer to item 3.1 for more details)

Received Date: Feb. 23, 2023

Test Date: Mar. 03 ~ Mar. 21, 2023

Issued Date: May 25, 2023

Applicant: ID TECH

Address: 10721 Walker Street, Cypress CA 90630-4720, United States

Issued By: Bureau Veritas Consumer Products Services (H.K.) Ltd., Taoyuan Branch
Lin Kou Laboratories

Lab Address: No. 47-2, 14th Ling, Chia Pau Vil., Lin Kou Dist., New Taipei City, Taiwan

Test Location: No.19, Hwa Ya 2nd Rd., Wen Hwa Vil., Kwei Shan Dist., Taoyuan City
33383, Taiwan

**FCC Registration /
Designation Number:** 788550 / TW0003



This report is governed by, and incorporates by reference, the Conditions of Testing as posted at the date of issuance of this report at <http://www.bureauveritas.com/home/about-us/our-business/cps/about-us/terms-conditions/> and is intended for your exclusive use. Any copying or replication of this report to or for any other person or entity, or use of our name or trademark, is permitted only with our prior written permission. This report sets forth our findings solely with respect to the test samples identified herein. The results set forth in this report are not indicative or representative of the quality or characteristics of the lot from which a test sample was taken or any similar or identical product unless specifically and expressly noted. Our report includes all of the tests requested by you and the results thereof based upon the information that you provided to us. Measurement uncertainty is only provided upon request for accredited tests. Statements of conformity are based on simple acceptance criteria without taking measurement uncertainty into account, unless otherwise requested in writing. You have 60 days from date of issuance of this report to notify us of any material error or omission caused by our negligence or if you require measurement uncertainty; provided, however, that such notice shall be in writing and shall specifically address the issue you wish to raise. A failure to raise such issue within the prescribed time shall constitute your unqualified acceptance of the completeness of this report, the tests conducted and the correctness of the report contents.

Table of Contents

Release Control Record	3
1 Certificate of Conformity	4
2 Summary of Test Results	5
2.1 Measurement Uncertainty.....	5
2.2 Modification Record	5
3 General Information	6
3.1 General Description of EUT	6
3.2 Description of Test Modes.....	7
3.2.1 Test Mode Applicability and Tested Channel Detail.....	7
3.3 Description of Support Units	9
3.3.1 Configuration of System under Test	9
3.4 General Description of Applied Standards and references.....	10
4 Test Types and Results	11
4.1 Radiated Emission Measurement.....	11
4.1.1 Limits of Radiated Emission Measurement	11
4.1.2 Test Instruments	12
4.1.3 Test Procedures.....	13
4.1.4 Deviation from Test Standard	13
4.1.5 Test Set Up	14
4.1.6 EUT Operating Conditions.....	14
4.1.7 Test Results	15
4.2 Conducted Emission Measurement.....	23
4.2.1 Limits of Conducted Emission Measurement	23
4.2.2 Test Instruments	23
4.2.3 Test Procedures.....	24
4.2.4 Deviation from Test Standard	24
4.2.5 Test Setup.....	24
4.2.6 EUT Operating Conditions.....	24
4.2.7 Test Results	25
4.3 Frequency Stability	27
4.3.1 Limits of Frequency Stability Measurement	27
4.3.2 Test Setup.....	27
4.3.3 Test Instruments	27
4.3.4 Test Procedure	27
4.3.5 Deviation from Test Standard	27
4.3.6 EUT Operating Conditions.....	27
4.3.7 Test Results	28
4.4 20 dB Bandwidth.....	29
4.4.1 Limits of 20 dB Bandwidth Measurement.....	29
4.4.2 Test Setup.....	29
4.4.3 Test Instruments	29
4.4.4 Test Procedures.....	29
4.4.5 Deviation from Test Standard	29
4.4.6 EUT Operating Conditions.....	29
4.4.7 Test Results	30
5 Pictures of Test Arrangements	31
Appendix – Information of the Testing Laboratories	32

Release Control Record

Issue No.	Description	Date Issued
RFBHLU-WTW-P23020721	Original Release	May 25, 2023

1 Certificate of Conformity

Product: NFC Card reader

Brand: ID TECH

Test Model: ID-80149014-001

Series Model: ID-80149014-00X (X=1~9) (refer to item 3.1 for more details)

Sample Status: Engineering Sample

Applicant: ID TECH

Test Date: Mar. 03 ~ Mar. 21, 2023

Standards: 47 CFR FCC Part 15, Subpart C (Section 15.225)

47 CFR FCC Part 15, Subpart C (Section 15.215)

ANSI C63.10-2013

The above equipment has been tested by **Bureau Veritas Consumer Products Services (H.K.) Ltd., Taoyuan Branch**, and found compliance with the requirement of the above standards. The test record, data evaluation & Equipment Under Test (EUT) configurations represented herein are true and accurate accounts of the measurements of the sample's RF characteristics under the conditions specified in this report.

Prepared by : Gina Liu , **Date:** May 25, 2023
Gina Liu / Specialist

Approved by : Jeremy Lin , **Date:** May 25, 2023
Jeremy Lin / Project Engineer

2 Summary of Test Results

47 CFR FCC Part 15, Subpart C (Section 15.225, 15.215)			
FCC Clause	Test Item	Result	Remarks
15.207	Conducted emission test	Pass	Meet the requirement of limit. Minimum passing margin is -7.26 dB at 13.55800 MHz.
15.225 (a)	The field strength of any emissions within the band 13.553-13.567 MHz	Pass	Meet the requirement of limit. Minimum passing margin is -49.4 dB at 13.56 MHz.
15.225 (b)	The field strength of any emissions within the bands 13.410-13.553 MHz and 13.567-13.710 MHz	Pass	Meet the requirement of limit.
15.225 (c)	The field strength of any emissions within the bands 13.110-13.410 MHz and 13.710-14.010 MHz	Pass	Meet the requirement of limit.
15.225 (d)	The field strength of any emissions appearing outside of the 13.110-14.010 MHz band	Pass	Meet the requirement of limit. Minimum passing margin is -4.0 dB at 433.56 MHz.
15.225 (e)	The frequency tolerance	Pass	Meet the requirement of limit.
15.215 (c)	20 dB Bandwidth	Pass	Meet the requirement of limit.
15.203	Antenna Requirement	Pass	No antenna connector is used.

Note: Determining compliance based on the results of the compliance measurement, not taking into account measurement instrumentation uncertainty.

2.1 Measurement Uncertainty

Where relevant, the following measurement uncertainty levels have been estimated for tests performed on the EUT as specified in CISPR 16-4-2:

Measurement	Frequency	Expanded Uncertainty (k=2) (±)
Conducted Emissions at mains ports	150 kHz ~ 30 MHz	2.79 dB
Radiated Emissions up to 1 GHz	9 kHz ~ 30 MHz	3.04 dB
	30 MHz ~ 200 MHz	2.93 dB
	200 MHz ~ 1000 MHz	2.95 dB

2.2 Modification Record

There were no modifications required for compliance.

3 General Information

3.1 General Description of EUT

Product	NFC Card reader
Brand	ID TECH
Test Model	ID-80149014-001
Series Model	ID-80149014-00X (X=1~9)
Status of EUT	Engineering Sample
Power Supply Rating	5.0 Vdc (host equipment)
Modulation Type	ASK
Data Rate	Type A: 106 kbit/s Type B: 106 kbit/s
Operating Frequency	13.56 MHz
Field Strength (Maximum)	34.6 dBuV/m (30m)
Antenna Type	Loop Antenna
Accessory Device	N/A
Data Cable Supplied	N/A

Note:

1. All models are listed as below.

Model Definition	Character	Description
X	1 - 9	Settings for different customers

2. Detail antenna specification please refer to antenna photos/or drawings, including antenna dimensions.
3. The above EUT information is declared by manufacturer and for more detailed features description, please refers to the manufacturer's specifications or user's manual.

3.2 Description of Test Modes

One channel was provided to this EUT:

Channel	Frequency (MHz)
1	13.56

3.2.1 Test Mode Applicability and Tested Channel Detail

EUT Configure Mode	Applicable To				Description
	RE	PLC	FS	EB	
-	√	√	√	√	

Where **RE:** Radiated Emission **PLC:** Power Line Conducted Emission
FS: Frequency Stability **EB:** 20 dB Bandwidth measurement

NOTE: The EUT had been pre-test on Type A and Type B. Type A was the worst case for final test.

Radiated Emission Test:

- Pre-Scan has been conducted to determine the worst-case mode from all possible combinations between available modulations, data rates and antenna ports (if EUT with antenna diversity architecture).
- Following channel(s) was (were) selected for the final test as listed below.

EUT Configure Mode	Available Channel	Tested Channel	Modulation Type
-	1	1	ASK

Power Line Conducted Emission Test:

- Pre-Scan has been conducted to determine the worst-case mode from all possible combinations between available modulations, data rates and antenna ports (if EUT with antenna diversity architecture).
- Following channel(s) was (were) selected for the final test as listed below.

EUT Configure Mode	Available Channel	Tested Channel	Modulation Type
-	1	1	ASK

Frequency Stability:

- This item includes all test value of each mode, but only includes spectrum plot of worst value of each mode.
- Pre-Scan has been conducted to determine the worst-case mode from all possible combinations between available modulations, data rates and antenna ports (if EUT with antenna diversity architecture).
- Following channel(s) was (were) selected for the final test as listed below.

EUT Configure Mode	Available Channel	Tested Channel	Modulation Type
-	1	1	ASK

20 dB Bandwidth:

- This item includes all test value of each mode, but only includes spectrum plot of worst value of each mode.
- Pre-Scan has been conducted to determine the worst-case mode from all possible combinations between available modulations, data rates and antenna ports (if EUT with antenna diversity architecture).
- Following channel(s) was (were) selected for the final test as listed below.

EUT Configure Mode	Available Channel	Tested Channel	Modulation Type
-	1	1	ASK

Test Condition:

Applicable To	Environmental Conditions	Input Power	Tested By
RE	24 deg. C, 68 % RH	120 Vac, 60 Hz	Vincent Chen
FS	22 deg. C, 68 % RH	5 Vdc	Vincent Chen
PLC	22.7 deg. C, 68.1 % RH	120 Vac, 60 Hz	Thomas Cheng
EB	22 deg. C, 67 % RH	5 Vdc	Vincent Chen

3.3 Description of Support Units

The EUT has been tested as an independent unit together with other necessary accessories or support units. The following support units or accessories were used to form a representative test configuration during the tests.

No.	Product	Brand	Model No.	Serial No.	FCC ID	Remarks
A.	IC Card	N/A	N/A	N/A	N/A	Supplied by applicant
B.	Notebook	DELL	E5420	33MJMQ1	NA	-
C.	NFC Card Type-A	N/A	N/A	N/A	N/A	Supplied by applicant

ID	Cable Descriptions	Qty.	Length (m)	Shielding (Yes/No)	Cores (Qty.)	Remarks
1.	Y Cable to USB and RS232	1	1.5	No	0	Supplied by applicant
2.	RS232 Cable	1	1.5	Yes	0	Provided by Lab

Note: All power cords of the above support units are non-shielded (1.8m).

3.3.1 Configuration of System under Test

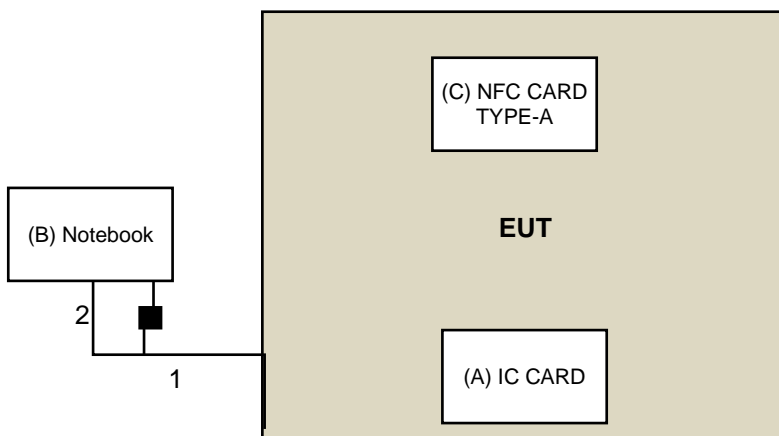

Under Table

3.4 General Description of Applied Standards and references

The EUT is a RF Product. According to the specifications of the manufacturer, it must comply with the requirements of the following standards and references:

FCC Part 15, Subpart C (15.225)

FCC Part 15, Subpart C (15.215)

ANSI C63.10-2013

All test items have been performed and recorded as per the above standards.

References Test Guidance :

KDB 414788 D01 Radiated Test Site v01r01

All test items have been performed as a reference to the above KDB test guidance.

4 Test Types and Results

4.1 Radiated Emission Measurement

4.1.1 Limits of Radiated Emission Measurement

- a. The field strength of any emissions within the band 13.553-13.567 MHz shall not exceed 15,848 microvolts/meter at 30 meters.
- b. Within the bands 13.410-13.553 MHz and 13.567-13.710 MHz, the field strength of any emissions shall not exceed 334 microvolts/meter at 30 meters.
- c. Within the bands 13.110-13.410 MHz and 13.710-14.010 MHz the field strength of any emissions shall not exceed 106 microvolts/meter at 30 meters.
- d. The field strength of any emissions appearing outside of the 13.110-14.010 MHz band shall not exceed the general radiated emission limits in §15.209 as below table:

Frequencies (MHz)	Field Strength (microvolts/meter)	Measurement Distance (meters)
0.009 ~ 0.490	2400/F (kHz)	300
0.490 ~ 1.705	24000/F (kHz)	30
1.705 ~ 30.0	30	30
30 ~ 88	100	3
88 ~ 216	150	3
216 ~ 960	200	3
Above 960	500	3

NOTE:

1. The lower limit shall apply at the transition frequencies.
2. Emission level (dBuV/m) = 20 log Emission level (uV/m).
3. For frequencies above 1000 MHz, the field strength limits are based on average detector, however, the peak field strength of any emission shall not exceed the maximum permitted average limits, specified above by more than 20 dB under any condition of modulation.

4.1.2 Test Instruments

Description & Manufacturer	Model No.	Serial No.	Date of Calibration	Due Date of Calibration
Software BV ADT	ADT_Radiated_ V7.6.15.9.5	NA	NA	NA
Antenna Tower & Turn Max-Full	MFA-440H	AT93021705	NA	NA
Turn Table Max-Full	MFT-201SS	NA	NA	NA
Turn Table Controller Max-Full	MG-7802	NA	NA	NA
Test Receiver KEYSIGHT	N9038A	MY55420137	Apr. 27, 2022	Apr. 26, 2023
Signal Analyzer Agilent	N9010A	MY52220207	Jan. 03, 2023	Jan. 02, 2024
Loop Antenna TESEQ	HLA 6121	45745	July 27, 2022	July 26, 2023
Loop Antenna EMCI	EM-6879	269	Sep. 19, 2022	Sep. 18, 2023
Pre-amplifier EMCI	EMC001340	980201	Sep. 23, 2022	Sep. 22, 2023
RF Coaxial Cable EMCI	5D-NM-BM	140903+140902	Jan. 07, 2023	Jan. 06, 2024
Pre-Amplifier EMCI	EMC 330H	980112	Oct. 01, 2022	Sep. 30, 2023
Bi_Log Antenna Schwarzbeck	VULB9168	9168-472	Oct. 21, 2022	Oct. 20, 2023
RF Coaxial Cable WOKEN	8D-FB	Cable-Ch10-01	Oct. 01, 2022	Sep. 30, 2023
Temperature & Humidity Chamber TERCHY	HRM-120RF	931022	Dec. 27, 2022	Dec. 26, 2023
DC power supply Keysight	U8002A	MY56330015	NA	NA
Digital Multimeter Fluke	87-III	70360742	Dec. 27, 2022	Dec. 26, 2023

Note: 1. The calibration interval of the above test instruments is 12 months and the calibrations are traceable to NML/ROC and NIST/USA.
 2. The test was performed in HY - 966 chamber 5.

4.1.3 Test Procedures

For Radiated Emission below 30 MHz

- a. The EUT was placed on the top of a rotating table 0.8 meters above the ground at a 3 meter chamber room. The table was rotated 360 degrees to determine the position of the highest radiation.
- b. The EUT was set 3 meters away from the interference-receiving antenna, which was mounted on the top of a variable-height antenna tower.
- c. Parallel, perpendicular, and ground-parallel orientations of the antenna are set to make the measurement.
- d. For each suspected emission, the EUT was arranged to its worst case and the rotatable table was turned from 0 degrees to 360 degrees to find the maximum reading.
- e. The test-receiver system was set to Quasi-Peak Detect Function and Specified Bandwidth with Maximum Hold Mode, except for the frequency band (9kHz-90kHz, 110Hz-490kHz) set to average detect function.

Note:

1. The resolution bandwidth and video bandwidth of test receiver/spectrum analyzer is 9 kHz at frequency below 30 MHz.
2. There is a comparison data of both open-field test site and semi-Anechoic chamber, and the result came out very similar.

For Radiated Emission above 30 MHz

- a. The EUT was placed on the top of a rotating table 0.8 meters above the ground at 3 meter chamber room for test. The table was rotated 360 degrees to determine the position of the highest radiation.
- b. The EUT was set 3 meters away from the interference-receiving antenna, which was mounted on the top of a variable-height antenna tower.
- c. The height of antenna is varied from one meter to four meters above the ground to determine the maximum value of the field strength. Both horizontal and vertical polarizations of the antenna are set to make the measurement.
- d. For each suspected emission, the EUT was arranged to its worst case and then the antenna was tuned to heights from 1 meter to 4 meters and the rotatable table was turned from 0 degrees to 360 degrees to find the maximum reading.
- e. The test-receiver system was set to quasi-peak detect function and specified bandwidth with maximum hold mode when the test frequency is below 1 GHz.

Note:

1. The resolution bandwidth and video bandwidth of test receiver/spectrum analyzer is 120 kHz for Quasi-peak detection (QP) at frequency below 1 GHz.
2. All modes of operation were investigated and the worst-case emissions are reported.

4.1.4 Deviation from Test Standard

No deviation.

4.1.5 Test Set Up

<Radiated Emission below 30 MHz>

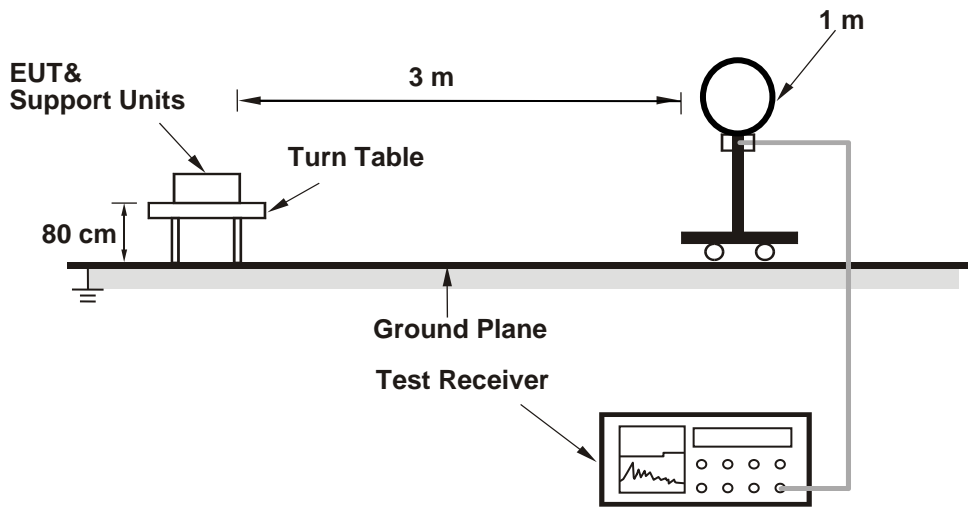

<Radiated Emission 30 MHz to 1 GHz>

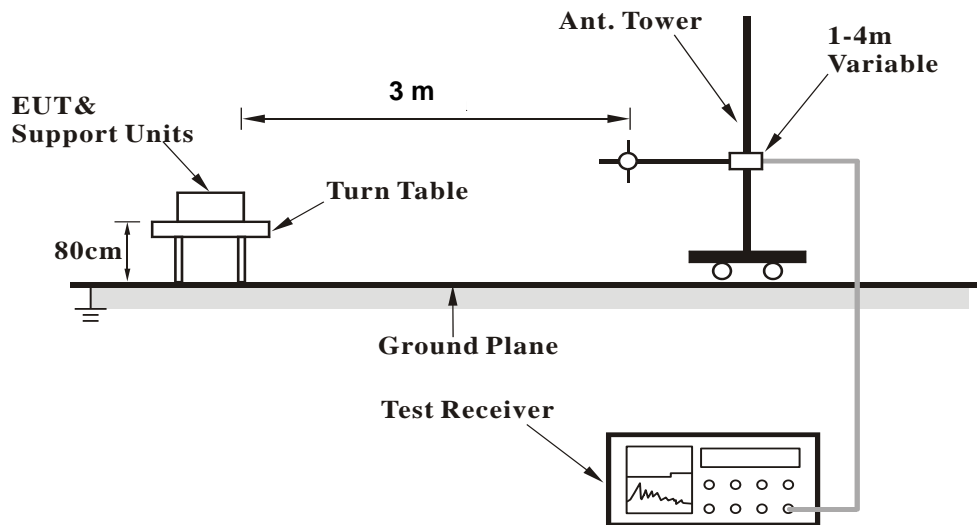

For the actual test configuration, please refer to the attached file (Test Setup Photo).

KDB 414788 OFS and Chamber Correlation Justification

- Base on FCC 15.31 (f) (2): measurements may be performed at a distance closer than that specified in the regulations; however, an attempt should be made to avoid making measurements in the near field.
- Open-field site and chamber correlation testing had been performed and chamber measured test result is the worst case test result.

4.1.6 EUT Operating Conditions

- a. Placed the EUT on the testing table.
- b. Set the EUT under transmission condition continuously at specific channel frequency.

4.1.7 Test Results

Type A

Channel	Channel 1	Frequency Range	13.11MHz ~ 14.01MHz
Input Power	120Vac, 60Hz	Detector Function & Bandwidth	Quasi-Peak (QP), 9kHz
Environmental Conditions	24°C, 73% RH	Tested By	Vincent Chen

Antenna Polarity : Parallel								
No	Frequency (MHz)	Emission Level (dBuV/m)	Limit (dBuV/m)	Margin (dB)	Antenna Height (m)	Table Angle (Degree)	Raw Value (dBuV)	Correction Factor (dB/m)
1	*13.56	34.6 QP	84.0	-49.4	1.0	2	52.8	-18.2

Remarks:

1. Emission Level(dBuV/m) = Raw Value(dBuV) + Correction Factor(dB/m)
2. Correction Factor(dB/m) = Antenna Factor(dB/m) + Cable Factor(dB) – Pre-Amplifier Factor(dB) + Distance Factor(dB)
3. Margin value = Emission Level – Limit value
4. The other emission levels were very low against the limit.
5. " * ": Fundamental frequency.
6. Above limits have been translated by the formula

The measured field strength was extrapolated to distance 30 meters distance factor@3m = $40 \cdot \log(3/30) = -40\text{dB}$, using the formula that the limit of field strength varies as the inverse distance square (40dB per decade of distance)

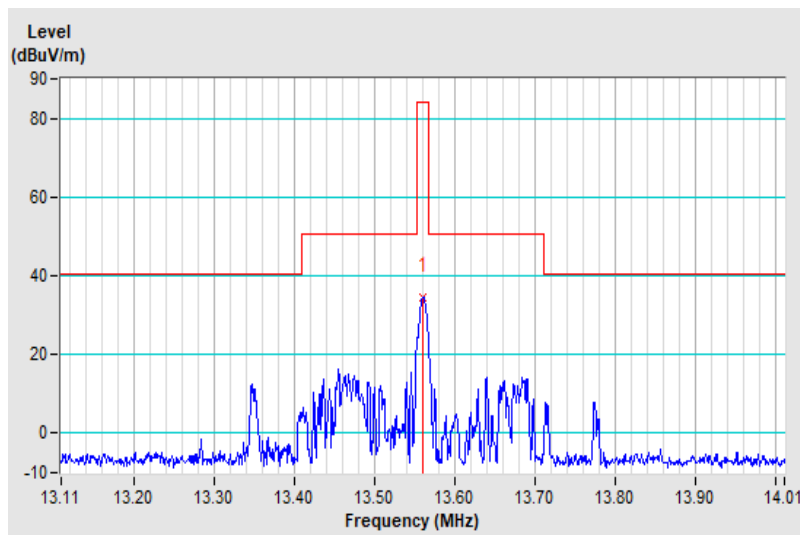

Channel	Channel 1	Frequency Range	13.11MHz ~ 14.01MHz
Input Power	120Vac, 60Hz	Detector Function & Bandwidth	Quasi-Peak (QP), 9kHz
Environmental Conditions	24°C, 73% RH	Tested By	Vincent Chen

Antenna Polarity : Perpendicular								
No	Frequency (MHz)	Emission Level (dBuV/m)	Limit (dBuV/m)	Margin (dB)	Antenna Height (m)	Table Angle (Degree)	Raw Value (dBuV)	Correction Factor (dB/m)
1	*13.56	30.2 QP	84.0	-53.8	1.0	261	48.4	-18.2

Remarks:

1. Emission Level(dBuV/m) = Raw Value(dBuV) + Correction Factor(dB/m)
2. Correction Factor(dB/m) = Antenna Factor(dB/m) + Cable Factor(dB) – Pre-Amplifier Factor(dB) + Distance Factor(dB)
3. Margin value = Emission Level – Limit value
4. The other emission levels were very low against the limit.
5. " * ": Fundamental frequency.
6. Above limits have been translated by the formula

The measured field strength was extrapolated to distance 30 meters distance factor@3m = $40 \cdot \log(3/30) = -40\text{dB}$, using the formula that the limit of field strength varies as the inverse distance square (40dB per decade of distance)

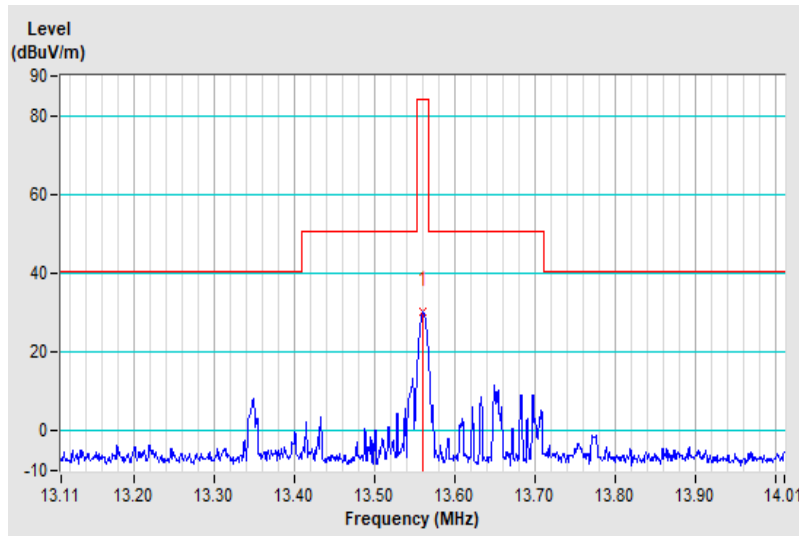

Channel	Channel 1	Frequency Range	13.11MHz ~ 14.01MHz
Input Power	120Vac, 60Hz	Detector Function & Bandwidth	Quasi-Peak (QP), 9kHz
Environmental Conditions	24°C, 73% RH	Tested By	Vincent Chen

Antenna Polarity : Ground-parallel								
No	Frequency (MHz)	Emission Level (dBuV/m)	Limit (dBuV/m)	Margin (dB)	Antenna Height (m)	Table Angle (Degree)	Raw Value (dBuV)	Correction Factor (dB/m)
1	*13.56	26.0 QP	84.0	-58.0	1.0	234	44.2	-18.2

Remarks:

1. Emission Level(dBuV/m) = Raw Value(dBuV) + Correction Factor(dB/m)
2. Correction Factor(dB/m) = Antenna Factor(dB/m) + Cable Factor(dB) – Pre-Amplifier Factor(dB) + Distance Factor(dB)
3. Margin value = Emission Level – Limit value
4. The other emission levels were very low against the limit.
5. " * ": Fundamental frequency.
6. Above limits have been translated by the formula

The measured field strength was extrapolated to distance 30 meters distance factor@3m = $40 \cdot \log(3/30) = -40\text{dB}$, using the formula that the limit of field strength varies as the inverse distance square (40dB per decade of distance)

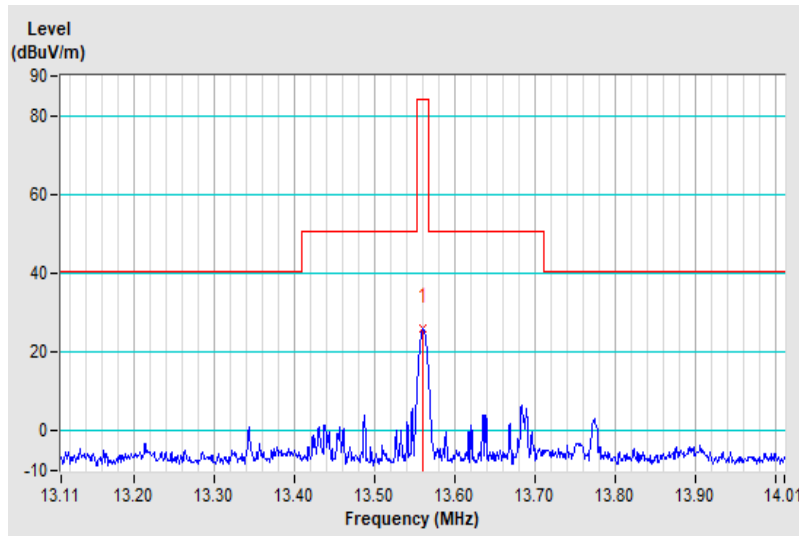

Channel	Channel 1	Frequency Range	9kHz ~ 30MHz
Input Power	120Vac, 60Hz	Detector Function & Bandwidth	Quasi-Peak (QP), 9kHz
Environmental Conditions	24°C, 73% RH	Tested By	Vincent Chen

Antenna Polarity : Parallel								
No	Frequency (MHz)	Emission Level (dBuV/m)	Limit (dBuV/m)	Margin (dB)	Antenna Height (m)	Table Angle (Degree)	Raw Value (dBuV)	Correction Factor (dB/m)
1	3.61	3.2 QP	29.5	-26.3	1.00	86	23.1	-19.9
2	7.27	1.2 QP	29.5	-28.3	1.00	272	20.4	-19.2
3	11.68	-3.2 QP	29.5	-32.7	1.00	312	15.0	-18.2
4	16.92	-4.2 QP	29.5	-33.7	1.00	223	13.9	-18.1
5	19.08	-4.4 QP	29.5	-33.9	1.00	201	13.7	-18.1
6	27.12	-2.6 QP	29.5	-32.1	1.00	49	15.5	-18.1

Remarks:

1. Emission Level(dBuV/m) = Raw Value(dBuV) + Correction Factor(dB/m)
2. Correction Factor(dB/m) = Antenna Factor(dB/m) + Cable Factor(dB) – Pre-Amplifier Factor(dB) + Distance Factor(dB)
3. Margin value = Emission Level – Limit value
4. The other emission levels were very low against the limit.
5. For 0.49 ~ 30MHz, the measured field strength was extrapolated to distance 30 meters Distance factor@3m = $40 \cdot \log(3/30) = -40\text{dB}$

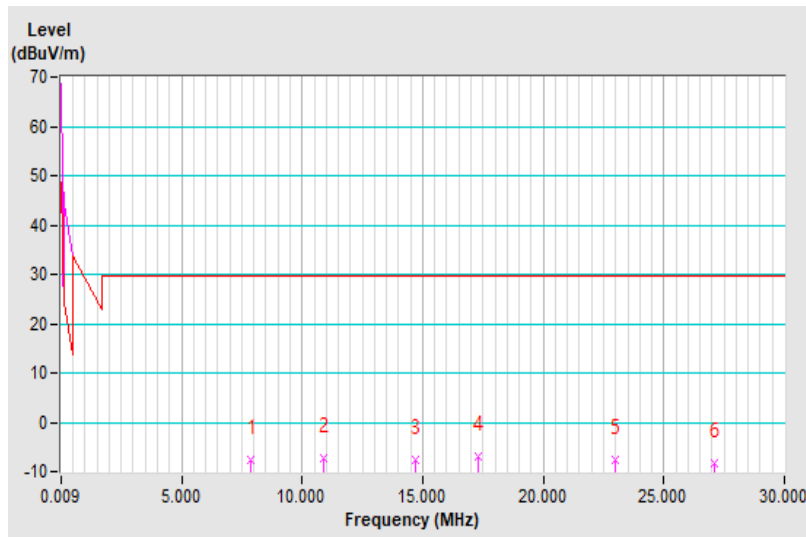

Channel	Channel 1	Frequency Range	9kHz ~ 30MHz
Input Power	120Vac, 60Hz	Detector Function & Bandwidth	Quasi-Peak (QP), 9kHz
Environmental Conditions	24°C, 69% RH	Tested By	Vincent Chen

Antenna Polarity : Perpendicular								
No	Frequency (MHz)	Emission Level (dBuV/m)	Limit (dBuV/m)	Margin (dB)	Antenna Height (m)	Table Angle (Degree)	Raw Value (dBuV)	Correction Factor (dB/m)
1	3.64	1.7 QP	29.5	-27.8	1.00	107	21.6	-19.9
2	6.73	3.9 QP	29.5	-25.6	1.00	151	23.3	-19.4
3	11.65	-4.0 QP	29.5	-33.5	1.00	112	14.2	-18.2
4	17.28	-3.2 QP	29.5	-32.7	1.00	52	14.9	-18.1
5	19.80	-4.9 QP	29.5	-34.4	1.00	34	13.2	-18.1
6	27.12	-4.0 QP	29.5	-33.5	1.00	166	14.1	-18.1

Remarks:

1. Emission Level(dBuV/m) = Raw Value(dBuV) + Correction Factor(dB/m)
2. Correction Factor(dB/m) = Antenna Factor(dB/m) + Cable Factor(dB) – Pre-Amplifier Factor(dB) + Distance Factor(dB)
3. Margin value = Emission Level – Limit value
4. The other emission levels were very low against the limit.
5. For 0.49 ~ 30MHz, the measured field strength was extrapolated to distance 30 meters Distance factor@3m = $40 \cdot \log(3/30) = -40\text{dB}$

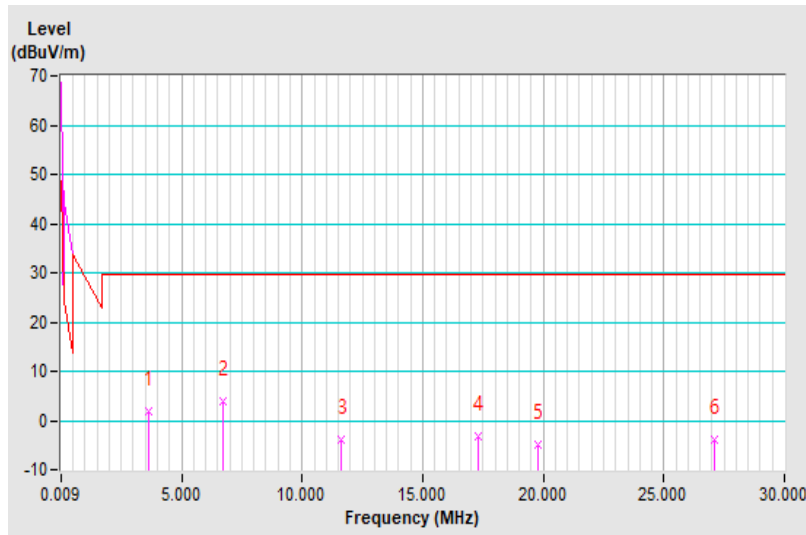

Channel	Channel 1	Frequency Range	9kHz ~ 30MHz
Input Power	120Vac, 60Hz	Detector Function & Bandwidth	Quasi-Peak (QP), 9kHz
Environmental Conditions	24°C, 69% RH	Tested By	Vincent Chen

Antenna Polarity : Ground-parallel								
No	Frequency (MHz)	Emission Level (dBuV/m)	Limit (dBuV/m)	Margin (dB)	Antenna Height (m)	Table Angle (Degree)	Raw Value (dBuV)	Correction Factor (dB/m)
1	3.61	2.3 QP	29.5	-27.2	1.00	102	22.2	-19.9
2	6.79	4.0 QP	29.5	-25.5	1.00	59	23.4	-19.4
3	11.71	-3.6 QP	29.5	-33.1	1.00	244	14.6	-18.2
4	18.45	-4.4 QP	29.5	-33.9	1.00	260	13.7	-18.1
5	22.26	-5.3 QP	29.5	-34.8	1.00	132	12.8	-18.1
6	27.12	-4.2 QP	29.5	-33.7	1.00	338	13.9	-18.1

Remarks:

1. Emission Level(dBuV/m) = Raw Value(dBuV) + Correction Factor(dB/m)
2. Correction Factor(dB/m) = Antenna Factor(dB/m) + Cable Factor(dB) – Pre-Amplifier Factor(dB) + Distance Factor(dB)
3. Margin value = Emission Level – Limit value
4. The other emission levels were very low against the limit.
5. For 0.49 ~ 30MHz, the measured field strength was extrapolated to distance 30 meters Distance factor@3m = $40 \cdot \log(3/30) = -40\text{dB}$

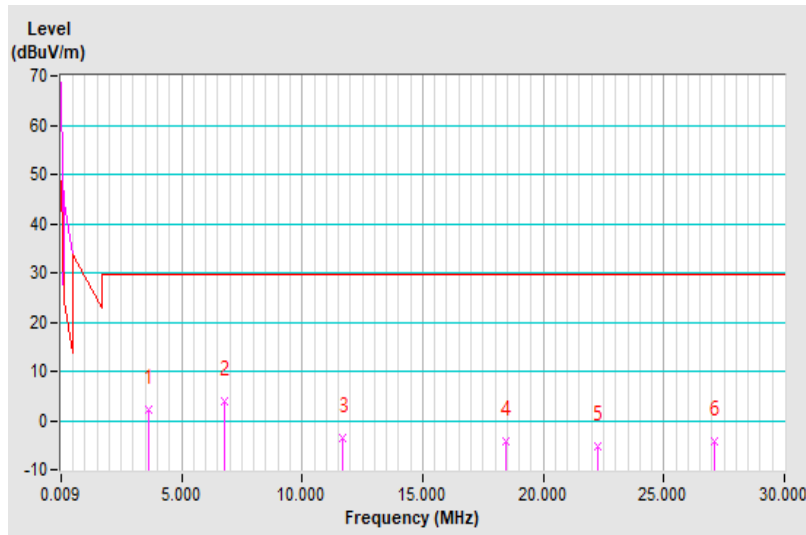

Channel	Channel 1	Frequency Range	30MHz ~ 1GHz
Input Power	120Vac, 60Hz	Detector Function	Quasi-Peak (QP)
Environmental Conditions	24°C, 68% RH	Tested By	Vincent Chen

Antenna Polarity & Test Distance : Horizontal at 3 m								
No	Frequency (MHz)	Emission Level (dBuV/m)	Limit (dBuV/m)	Margin (dB)	Antenna Height (m)	Table Angle (Degree)	Raw Value (dBuV)	Correction Factor (dB/m)
1	67.83	31.8 QP	40.0	-8.2	1.99 H	11	45.8	-14.0
2	108.58	33.2 QP	43.5	-10.3	1.99 H	36	48.4	-15.2
3	230.81	35.5 QP	46.0	-10.5	1.00 H	150	50.5	-15.0
4	263.79	40.5 QP	46.0	-5.5	1.00 H	72	53.5	-13.0
5	406.40	40.3 QP	46.0	-5.7	1.00 H	299	49.7	-9.4
6	433.56	42.0 QP	46.0	-4.0	1.99 H	319	50.5	-8.5
7	827.42	39.4 QP	46.0	-6.6	1.00 H	348	41.0	-1.6

Remarks:

1. Emission Level(dBuV/m) = Raw Value(dBuV) + Correction Factor(dB/m)
2. Correction Factor(dB/m) = Antenna Factor(dB/m) + Cable Factor(dB) – Pre-Amplifier Factor(dB)
3. Margin value = Emission Level – Limit value
4. The other emission levels were very low against the limit of frequency range 30MHz~1000MHz.

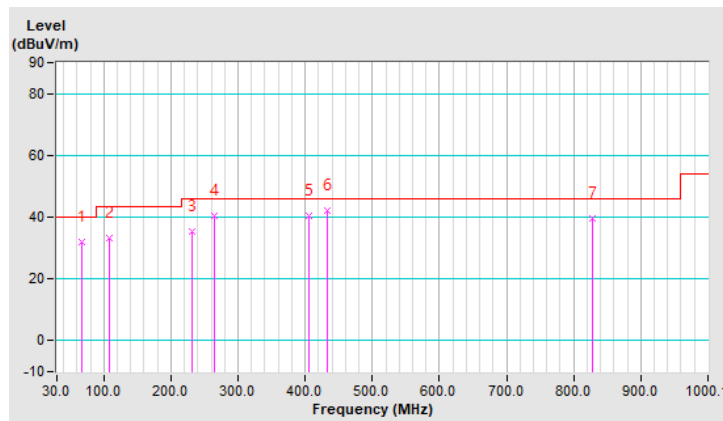

Channel	Channel 1	Frequency Range	30MHz ~ 1GHz
Input Power	120Vac, 60Hz	Detector Function	Quasi-Peak (QP)
Environmental Conditions	24°C, 68% RH	Tested By	Vincent Chen

Antenna Polarity & Test Distance : Vertical at 3 m								
No	Frequency (MHz)	Emission Level (dBuV/m)	Limit (dBuV/m)	Margin (dB)	Antenna Height (m)	Table Angle (Degree)	Raw Value (dBuV)	Correction Factor (dB/m)
1	54.25	34.7 QP	40.0	-5.3	1.01 V	290	47.2	-12.5
2	108.58	32.8 QP	43.5	-10.7	1.01 V	272	48.0	-15.2
3	263.79	32.0 QP	46.0	-14.0	2.00 V	2	45.0	-13.0
4	480.13	38.1 QP	46.0	-7.9	1.01 V	52	45.5	-7.4
5	635.34	35.6 QP	46.0	-10.4	1.01 V	225	40.1	-4.5
6	854.59	37.0 QP	46.0	-9.0	2.00 V	197	38.5	-1.5

Remarks:

1. Emission Level(dBuV/m) = Raw Value(dBuV) + Correction Factor(dB/m)
2. Correction Factor(dB/m) = Antenna Factor(dB/m) + Cable Factor(dB) – Pre-Amplifier Factor(dB)
3. Margin value = Emission Level – Limit value
4. The other emission levels were very low against the limit of frequency range 30MHz~1000MHz.

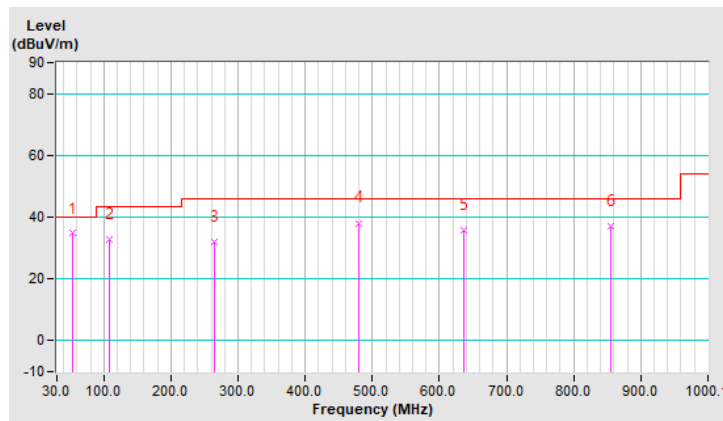

4.2 Conducted Emission Measurement

4.2.1 Limits of Conducted Emission Measurement

Frequency (MHz)	Conducted Limit (dBuV)	
	Quasi-Peak	Average
0.15 - 0.5	66 - 56	56 - 46
0.50 - 5.0	56	46
5.0 - 30.0	60	50

Note:

1. The lower limit shall apply at the transition frequencies.
2. The limit decreases in line with the logarithm of the frequency in the range of 0.15 to 0.50 MHz.
3. All emanations from a class A/B digital device or system, including any network of conductors and apparatus connected thereto, shall not exceed the level of field strengths specified above.

4.2.2 Test Instruments

Description & Manufacturer	Model No.	Serial No.	Date of Calibration	Due Date of Calibration
Test Receiver ROHDE & SCHWARZ	ESCI	100613	Dec. 05, 2022	Dec. 04, 2023
RF signal cable Woken	5D-FB	Cable-cond1-01	Jan. 07, 2023	Jan. 06, 2024
LISN/AMN ROHDE & SCHWARZ (Peripheral)	ENV216	101196	May 24, 2022	May 23, 2023
LISN/AMN ROHDE & SCHWARZ (Peripheral)	ESH3-Z5	100311	Sep. 12, 2022	Sep. 11, 2023
Software ADT	BV ADT_Cond_ V7.3.7.4	NA	NA	NA

- Note: 1. The calibration interval of the above test instruments is 12 months and the calibrations are traceable to NML/ROC and NIST/USA.
2. The test was performed in HwaYa Shielded Room 1 (Conduction 1).
 3. The VCCI Site Registration No. is C-12040.
 4. Test Date: 2023/3/21

4.2.3 Test Procedures

- a. The EUT was placed 0.4 meters from the conducting wall of the shielded room with EUT being connected to the power mains through a line impedance stabilization network (LISN). Other support units were connected to the power mains through another LISN. The two LISNs provide 50 ohm/50 uH of coupling impedance for the measuring instrument.
- b. Both lines of the power mains connected to the EUT were checked for maximum conducted interference.
- c. The frequency range from 150 kHz to 30 MHz was searched. Emission levels under (Limit – 20 dB) was not recorded.

Note: The resolution bandwidth and video bandwidth of test receiver is 9 kHz for quasi-peak detection (QP) and average detection (AV) at frequency 0.15 MHz - 30 MHz.

4.2.4 Deviation from Test Standard

No deviation.

4.2.5 Test Setup

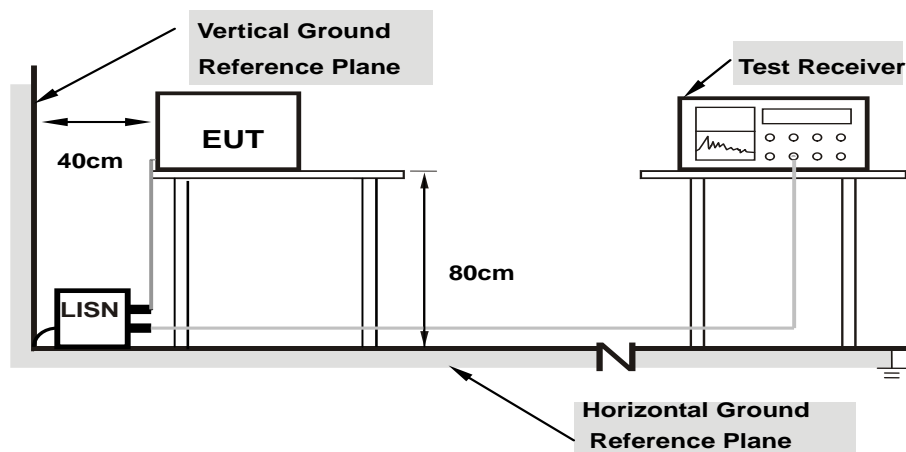

- Note:**
1. Support units were connected to second LISN.
 2. Both of LISNs (AMN) are 80 cm from EUT and at least 80 from other units and other metal planes

For the actual test configuration, please refer to the attached file (Test Setup Photo).

4.2.6 EUT Operating Conditions

- a. Placed the EUT on the testing table.
- b. Set the EUT under transmission condition continuously at specific channel frequency.

4.2.7 Test Results

RF Mode	TX NFC-13.56MHz	Channel	CH 1 : 13.56 MHz
Frequency Range	150kHz ~ 30MHz	Detector Function & Resolution Bandwidth	Quasi-Peak (QP) / Average (AV), 9kHz

Phase Of Power : Line (L)										
No	Frequency (MHz)	Correction Factor (dB)	Reading Value (dBuV)		Emission Level (dBuV)		Limit (dBuV)		Margin (dB)	
			Q.P.	AV.	Q.P.	AV.	Q.P.	AV.	Q.P.	AV.
1	0.15000	10.12	44.92	27.77	55.04	37.89	66.00	56.00	-10.96	-18.11
2	0.16600	10.12	41.50	22.24	51.62	32.36	65.16	55.16	-13.54	-22.80
3	0.65000	10.18	20.01	13.29	30.19	23.47	56.00	46.00	-25.81	-22.53
4	4.75800	10.35	14.08	4.32	24.43	14.67	56.00	46.00	-31.57	-31.33
5	13.55800	10.69	32.20	32.04	42.89	42.73	60.00	50.00	-17.11	-7.27
6	15.69800	10.78	14.65	7.09	25.43	17.87	60.00	50.00	-34.57	-32.13

Remarks:

1. Q.P. and AV. are abbreviations of quasi-peak and average individually.
2. The emission levels of other frequencies were very low against the limit.
3. Margin value = Emission level – Limit value
4. Correction factor = Insertion loss + Cable loss
5. Emission Level = Correction Factor + Reading Value

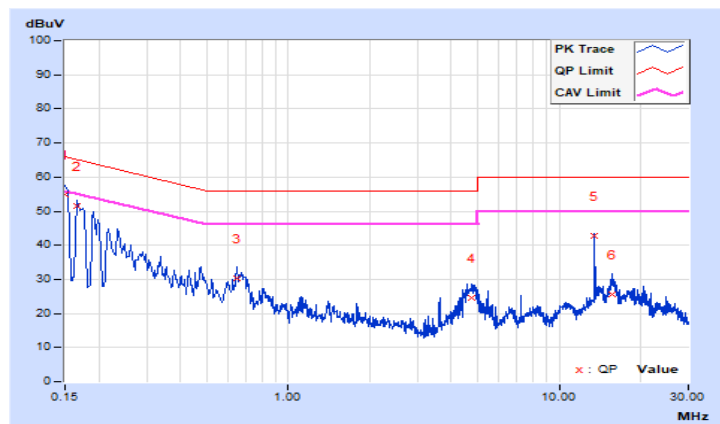

RF Mode	TX NFC-13.56MHz	Channel	CH 1 : 13.56 MHz
Frequency Range	150kHz ~ 30MHz	Detector Function & Resolution Bandwidth	Quasi-Peak (QP) / Average (AV), 9kHz

Phase Of Power : Neutral (N)										
No	Frequency (MHz)	Correction Factor (dB)	Reading Value (dBuV)		Emission Level (dBuV)		Limit (dBuV)		Margin (dB)	
			Q.P.	AV.	Q.P.	AV.	Q.P.	AV.	Q.P.	AV.
1	0.15000	10.13	45.01	26.97	55.14	37.10	66.00	56.00	-10.86	-18.90
2	0.16535	10.14	41.31	22.57	51.45	32.71	65.19	55.19	-13.74	-22.48
3	0.66111	10.20	19.60	13.18	29.80	23.38	56.00	46.00	-26.20	-22.62
4	4.83400	10.34	17.01	9.52	27.35	19.86	56.00	46.00	-28.65	-26.14
5	13.55800	10.56	32.95	32.18	43.51	42.74	60.00	50.00	-16.49	-7.26
6	15.75800	10.61	15.14	7.93	25.75	18.54	60.00	50.00	-34.25	-31.46

Remarks:

1. Q.P. and AV. are abbreviations of quasi-peak and average individually.
2. The emission levels of other frequencies were very low against the limit.
3. Margin value = Emission level – Limit value
4. Correction factor = Insertion loss + Cable loss
5. Emission Level = Correction Factor + Reading Value

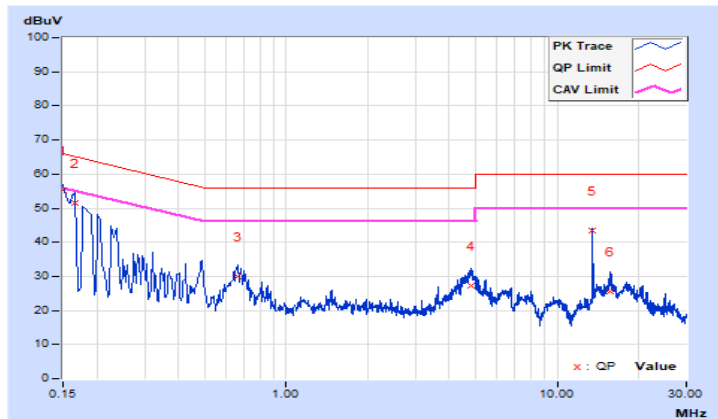

4.3 Frequency Stability

4.3.1 Limits of Frequency Stability Measurement

The frequency tolerance of the carrier signal shall be maintained within +/- 0.01 % of the operating frequency over a temperature variation of -20 degrees to 50 degrees C at normal supply voltage, and for a variation in the primary supply voltage from 85 % to 115 % of the rated supply voltage at a temperature of 20 degrees C.

4.3.2 Test Setup

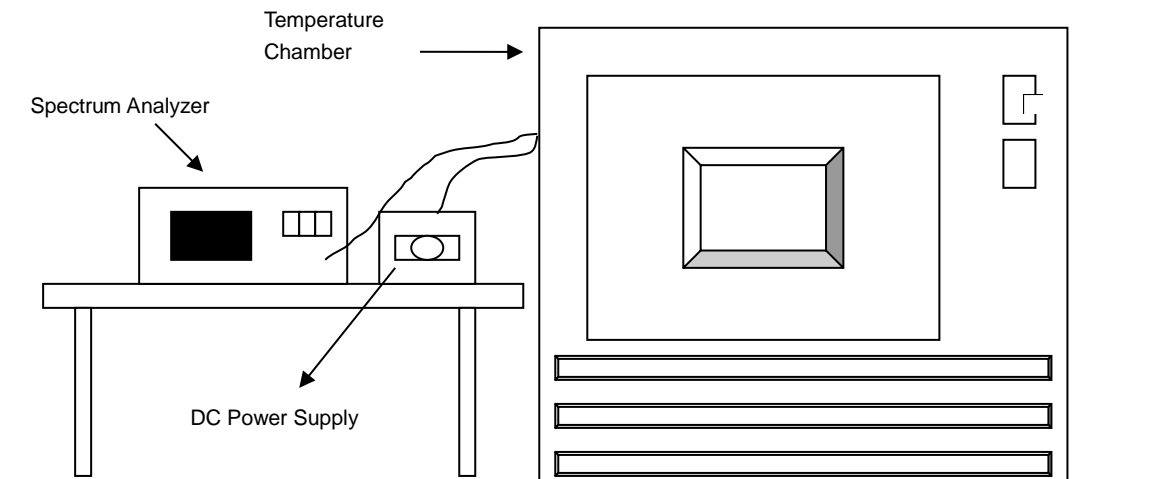

4.3.3 Test Instruments

Refer to section 4.1.2 to get information of above instrument.

4.3.4 Test Procedure

- The EUT was placed inside the environmental test chamber and powered by nominal DC voltage.
- Turned the EUT on and coupled its output to a spectrum analyzer.
- Turned the EUT off and set the chamber to the highest temperature specified.
- Allowed sufficient time (approximately 30 min) for the temperature of the chamber to stabilize then turned the EUT on and measured the operating frequency after 2, 5, and 10 minutes.
- Repeated step c and d with the every 10 degrees reduction until the lowest temperature achieved.
- The test chamber was allowed to stabilize at +20 degree C for a minimum of 30 minutes. The supply voltage was then adjusted on the EUT from 85 % to 115 % and the frequency record.

4.3.5 Deviation from Test Standard

No deviation.

4.3.6 EUT Operating Conditions

- Placed the EUT on the testing table.
- Set the EUT under transmission condition continuously at specific channel frequency.

4.3.7 Test Results

Frequency Stability Versus Temperature									
Temp. (°C)	Power Supply (Vdc)	0 Minute		2 Minute		5 Minute		10 Minute	
		Measured Frequency	Frequency Drift	Measured Frequency	Frequency Drift	Measured Frequency	Frequency Drift	Measured Frequency	Frequency Drift
		(MHz)	%	(MHz)	%	(MHz)	%	(MHz)	%
85	5	13.55999	-0.00007	13.55999	-0.00007	13.55999	-0.00007	13.55999	-0.00007
80	5	13.55994	-0.00044	13.55996	-0.00029	13.55996	-0.00029	13.55995	-0.00037
70	5	13.56	0.00000	13.55999	-0.00007	13.55999	-0.00007	13.56001	0.00007
60	5	13.56005	0.00037	13.56004	0.00029	13.56004	0.00029	13.56005	0.00037
50	5	13.56001	0.00007	13.56002	0.00015	13.56001	0.00007	13.56001	0.00007
40	5	13.56	0.00000	13.55999	-0.00007	13.56	0.00000	13.56	0.00000
30	5	13.55993	-0.00052	13.55993	-0.00052	13.55994	-0.00044	13.55992	-0.00059
20	5	13.55995	-0.00037	13.55996	-0.00029	13.55995	-0.00037	13.55995	-0.00037
10	5	13.55997	-0.00022	13.55997	-0.00022	13.55997	-0.00022	13.55997	-0.00022
0	5	13.56002	0.00015	13.56002	0.00015	13.56001	0.00007	13.56002	0.00015
-10	5	13.55998	-0.00015	13.55997	-0.00022	13.55998	-0.00015	13.55998	-0.00015
-20	5	13.56002	0.00015	13.56003	0.00022	13.56003	0.00022	13.56004	0.00029
-30	5	13.55995	-0.00037	13.55995	-0.00037	13.55995	-0.00037	13.55996	-0.00029
-40	5	13.55999	-0.0001	13.55998	-0.0002	13.55999	-0.0001	13.56	0.0000

Frequency Stability Versus Voltage									
Temp. (°C)	Power Supply (Vdc)	0 Minute		2 Minute		5 Minute		10 Minute	
		Measured Frequency	Frequency Drift	Measured Frequency	Frequency Drift	Measured Frequency	Frequency Drift	Measured Frequency	Frequency Drift
		(MHz)	%	(MHz)	%	(MHz)	%	(MHz)	%
20	5.75	13.55995	-0.00037	13.55996	-0.00029	13.55995	-0.00037	13.55995	-0.00037
	5	13.55995	-0.00037	13.55996	-0.00029	13.55995	-0.00037	13.55995	-0.00037
	4.25	13.55995	-0.00037	13.55996	-0.00029	13.55995	-0.00037	13.55995	-0.00037

4.4 20 dB Bandwidth

4.4.1 Limits of 20 dB Bandwidth Measurement

The 20 dB bandwidth shall be specified in operating frequency band.

4.4.2 Test Setup

Refer to section 4.1.5.

4.4.3 Test Instruments

Refer to section 4.1.2 to get information of above instrument.

4.4.4 Test Procedures

The bandwidth of the fundamental frequency was measured by spectrum analyzer with 958 Hz RBW and 3 kHz VBW. The 20 dB bandwidth is defined as the total spectrum the power of which is higher than peak power minus 20 dB.

4.4.5 Deviation from Test Standard

No deviation.

4.4.6 EUT Operating Conditions

- a. Placed the EUT on the testing table.
- b. Set the EUT under transmission condition continuously at specific channel frequency.

4.4.7 Test Results

20 dBc Point (Low)	20 dBc Point (High)	Operating Frequency Band (MHz)	Pass / Fail
13.55966 MHz	13.56142 MHz	13.553~13.567	Pass

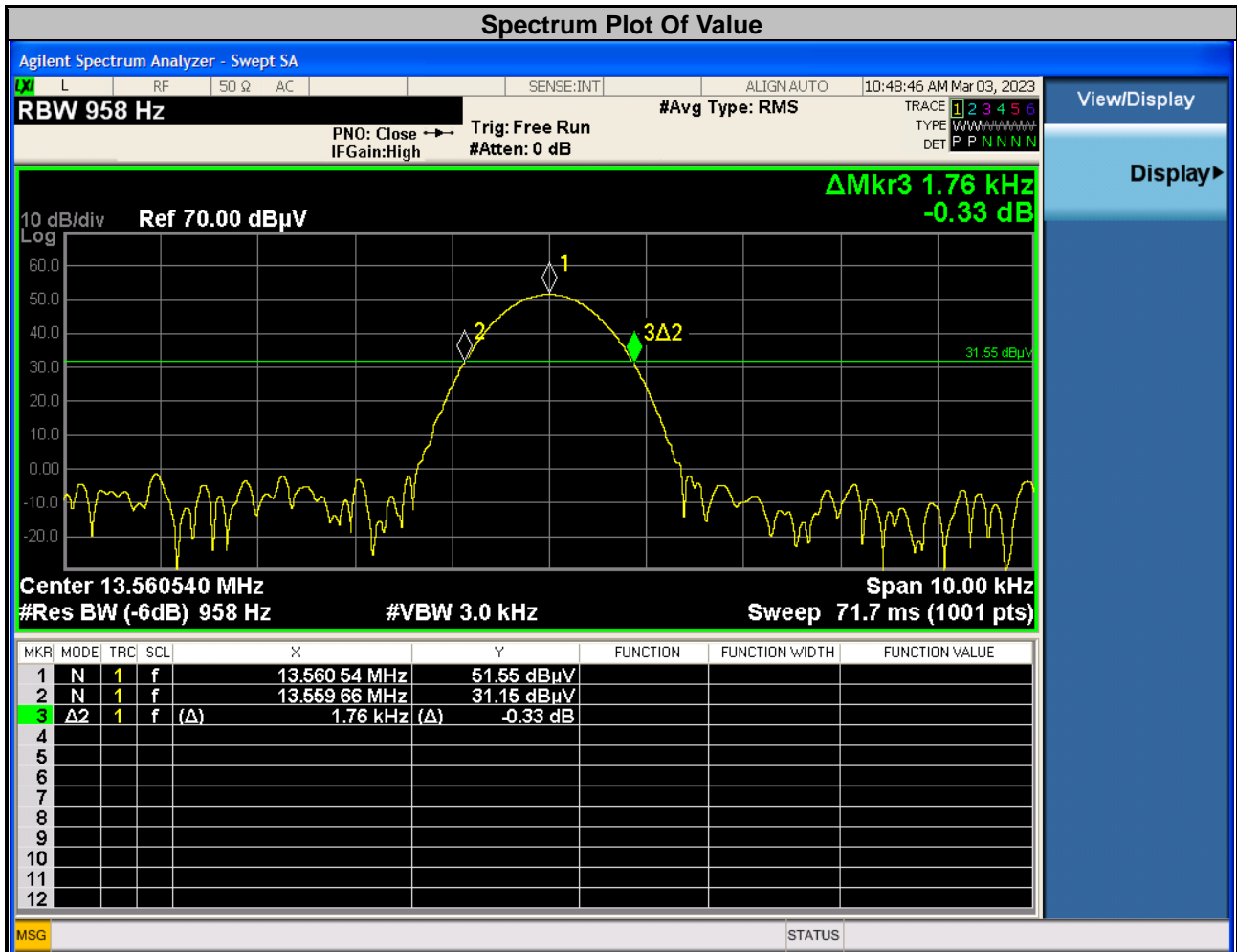

Note: The signal look like CW signal, so RBW can't be match 1~5 % OBW.

5 Pictures of Test Arrangements

Please refer to the attached file (Test Setup Photo).

Appendix – Information of the Testing Laboratories

We, Bureau Veritas Consumer Products Services (H.K.) Ltd., Taoyuan Branch, were founded in 1988 to provide our best service in EMC, Radio, Telecom and Safety consultation. Our laboratories are FCC recognized accredited test firms and accredited according to ISO/IEC 17025.

If you have any comments, please feel free to contact us at the following:

Lin Kou EMC/RF Lab

Tel: 886-2-26052180

Fax: 886-2-26051924

Hsin Chu EMC/RF/Telecom Lab

Tel: 886-3-6668565

Fax: 886-3-6668323

Hwa Ya EMC/RF/Safety Lab

Tel: 886-3-3183232

Fax: 886-3-3270892

Email: service.adt@tw.bureauveritas.com

Web Site: www.bureauveritas-adt.com

The address and road map of all our labs can be found in our web site also.

--- END ---