

FCC 47 CFR PART 15 SUBPART C

Product Type : Bluetooth Magnetic Stripe Reader
Applicant : ID TECH
Address : 10721 Walker Street, Cypress, CA 90630, USA
Trade Name : ID TECH
Model Number : ID-80125001-zyx
Test Specification : FCC 47 CFR PART 15 SUBPART C: Oct., 2010
Canada RSS-210 ISSUE 8: Dec., 2010
Canada RSS-Gen ISSUE 3: Dec., 2010
ANSI C63.4-2009
Application Purpose : Original
Receive Date : Mar. 20, 2012
Issue Date : Apr. 13, 2012

Issue by

A Test Lab Techno Corp.
No. 140-1, Changan Street, Bade City,
Taoyuan County 334, Taiwan R.O.C.
Tel : +886-3-2710188 / Fax : +886-3-2710190



Taiwan Accreditation Foundation accreditation number: 1330

Note: This report shall not be reproduced except in full, without the written approval of A Test Lab Techno Corp. This document may be altered or revised by A Test Lab Techno Corp. personnel only, and shall be noted in the revision section of the document. The client should not use it to claim product endorsement by TAF, or any government agencies. The test results in the report only apply to the tested sample.

Revision History

Rev.	Issue Date	Revisions	Revised By
00	Apr. 13, 2012	Initial Issue	

Verification of Compliance

Issued Date: 2012/04/13

Product Type : Bluetooth Magnetic Stripe Reader
Applicant : ID TECH
Address : 10721 Walker Street, Cypress, CA 90630, USA
Trade Name : ID TECH
Model Number : ID-80125001-zyx
FCC ID : WQJ-ID80125001ZYX
EUT Rated Voltage : DC 5V, 40mA
Test Voltage : 120 Vac / 60 Hz
Applicable Standard : FCC 47 CFR PART 15 SUBPART C: Oct., 2010
Canada RSS-210 ISSUE 8: Dec., 2010
Canada RSS-Gen ISSUE 3: Dec., 2010
ANSI C63.4-2009
Test Result : Complied
Application Purpose : Original
Performing Lab. : A Test Lab Techno Corp.

No. 140-1, Changan Street, Bade City,
Taoyuan County 334, Taiwan R.O.C.

Tel : +886-3-2710188 / Fax : +886-3-2710190

Taiwan Accreditation Foundation accreditation number:
1330

<http://www.atl-lab.com.tw/e-index.htm>



The above equipment was tested by A Test Lab Techno Corp. The test data, data evaluation, test procedures, and equipment configurations shown in this report were made in accordance with the procedures given in ANSI C63.4: 2009 and the energy emitted by the sample tested as described in this report is in compliance with the requirements of FCC Rules Part 15.207, 15.209, 15.247 .

The test results of this report relate only to the tested sample identified in this report.

Approved By : 

(Manager)

(Murphy Wang)

Reviewed By : 

(Testing Engineer)

(Fly Lu)

TABLE OF CONTENTS

1	General Information	6
2	EUT Description	7
3	Test Methodology.....	8
3.1.	Mode of Operation.....	8
3.2.	EUT Exercise Software.....	8
3.3.	Configuration of Test System Details.....	9
3.4.	Test Site Environment.....	10
4	Conducted Emission Measurement	11
4.1.	Limit	11
4.2.	Test Instruments	11
4.3.	Test Setup.....	11
4.4.	Test Procedure.....	12
4.5.	Test Result.....	13
5	Radiated Interference Measurement	15
5.1.	Limit	15
5.2.	Test Instruments	15
5.3.	Setup	16
5.4.	Test Procedure.....	17
5.5.	Test Result.....	19
6	Maximum Conducted Output Power Measurement.....	22
6.1.	Limit	22
6.2.	Test Setup.....	22
6.3.	Test Instruments	22
6.4.	Test Procedure.....	22
6.5.	Test Result.....	23
7	Minimum 20dB RF Bandwidth Measurement	24
7.1.	Limit	24
7.2.	Test Setup.....	24
7.3.	Test Instruments	24
7.4.	Test Procedure.....	24
7.5.	Test Result.....	25
7.6.	Test Graphs	26
8	Carrier Frequency Separation Measurement	27
8.1.	Limit	27
8.2.	Test Setup.....	27
8.3.	Test Instruments	27
8.4.	Test Procedure.....	28
8.5.	Test Result.....	28
8.6.	Test Graphs	29

9	Number of Hopping Measurement	30
9.1.	Limit	30
9.2.	Test Setup.....	30
9.3.	Test Instruments	30
9.4.	Test Procedure.....	30
9.5.	Test Result.....	31
9.6.	Test Graphs	32
10	Time of Occupancy (Dwell Time) Measurement.....	33
10.1.	Limit	33
10.2.	Test Setup.....	33
10.3.	Test Instruments	33
10.4.	Test Procedure.....	33
10.5.	Test Result.....	34
10.6.	Test Graphs	35
11	Out of Band Conducted Emissions Measurement	36
11.1.	Limit	36
11.2.	Test Setup.....	36
11.3.	Test Instruments	36
11.4.	Test Procedure.....	36
11.5.	Test Graphs	37
12	Band Edges Measurement	38
12.1.	Limit	38
12.2.	Test Setup.....	38
12.3.	Test Instruments	38
12.4.	Test Procedure.....	39
12.5.	Test Result.....	40
13	99 % Occupied Bandwidth Measurement	46
13.1.	Limit	46
13.2.	Test Setup.....	46
13.3.	Test Instruments	46
13.4.	Test Procedure.....	46
13.5.	Test Result.....	47
13.6.	Test Graphs	48
14	Antenna Measurement.....	49
14.1.	Limit	49
14.2.	Antenna Connector Construction	49

1 General Information

1.1 Summary of Test Result

Standard		Item	Result	Remark
15.247	RSS-GEN			
15.207	7.2.2	AC Power Conducted Emission	PASS	-----
-----	6	Receiver Radiated Emissions	PASS	-----
Standard		Item	Result	Remark
15.247	RSS-210			
15.247(c)	A8.5	Transmitter Radiated Emissions	PASS	-----
15.247(b)(1)	A8.4 (2)	Max. Output Power	PASS	-----
15.247(a)(1)	A8.1 (1)	20dB RF Bandwidth	PASS	-----
15.247(a)(1)(iii)	A8.1 (2)	Carrier Frequency Separation	PASS	-----
15.247(a)(1)(iii)	A8.1 (4)	Number of Hopping	PASS	-----
15.247(a)(1)(iii)	A8.1 (4)	Time of Occupancy (Dwell Time)	PASS	-----
15.247(c)	A8.5	Out of Band Conducted Spurious Emission	PASS	-----
15.247(c)	A8.5	Band Edge Measurement	PASS	-----
15.203	-	Antenna Requirement	PASS	-----

The test results of this report relate only to the tested sample(s) identified in this report. Manufacturer or whom it may concern should recognize the pass or fail of the test result.

1.2 Measurement Uncertainty

Conducted Emission

The measurement uncertainty is evaluated as ± 2.24 dB.

Radiated Emission

The measurement uncertainty is evaluated as ± 3.072 dB.

2 EUT Description

Product	:	Bluetooth Magnetic Stripe Reader
Trade Name	:	ID TECH
Model Number	:	ID-80125001-zyx z = for color of the rubber, 0 represent default dark grey color y = for color of unit, 0 represent default black color x = customer logo, 1 represent <IDTECH> logo
Applicant	:	ID TECH 10721 Walker Street, Cypress, CA 90630, USA
Manufacturer	:	ID TECH 10721 Walker Street, Cypress, CA 90630, USA
FCC ID	:	WQJ-ID80125001ZYX
Frequency Range	:	2402 ~ 2480 MHz
Modulation Type	:	GFSK for 1Mbps
Antenna Type	:	Multilayer Chip Antenna
Antenna Gain	:	2.5 dBi
RF Output Power (Conducted)	:	GFSK for 1Mbps 2.40 dBm / 0.00174 W

3 Test Methodology

3.1. Mode of Operation

Decision of Test ATL has verified the construction and function in typical operation. All the test modes were carried out with the EUT in normal operation, which was shown in this test report and defined as:

Test Mode
Mode 1: Normal Operation Mode
Mode 2: GFSK Link Mode
Mode 3: Receiver Mode

Description of Test Modes

Preliminary tests were performed in different modulation to find the worst case. The modulation shown in the table below is the worst-case. Investigation has been done on all the possible configurations for searching the worst cases. The following table is a list of the test modes shown in this test report.

Modulation Type	Channel	Frequency (MHz)	Packet Type	Peak Conducted Power		Worst Case
				(dBm)	(W)	
GFSK	Low	2402	DH1	2.29	0.00169	<input type="checkbox"/>
	Low	2402	DH3	2.31	0.00170	<input type="checkbox"/>
	Low	2402	DH5	2.40	0.00174	<input checked="" type="checkbox"/>
	Middle	2441	DH1	1.18	0.00131	<input type="checkbox"/>
	Middle	2441	DH3	1.20	0.00132	<input type="checkbox"/>
	Middle	2441	DH5	1.28	0.00134	<input type="checkbox"/>
	High	2480	DH1	-0.36	0.00092	<input type="checkbox"/>
	High	2480	DH3	-0.33	0.00093	<input type="checkbox"/>
High	2480	DH5	-0.31	0.00093	<input type="checkbox"/>	

Tested System Details

The types for all equipments, plus descriptions of all cables used in the tested system (including inserted cards) are:

	Product	Manufacturer	Model Number	Serial Number	Power Cord
1.	---	---	---	---	---

3.2. EUT Exercise Software

1.	Setup the EUT and Bluetooth Tester (CBT) as shown on 3.3.
2.	Turn on the power of all equipment.
3.	EUT run test program.

3.3. Configuration of Test System Details

Conducted Emission

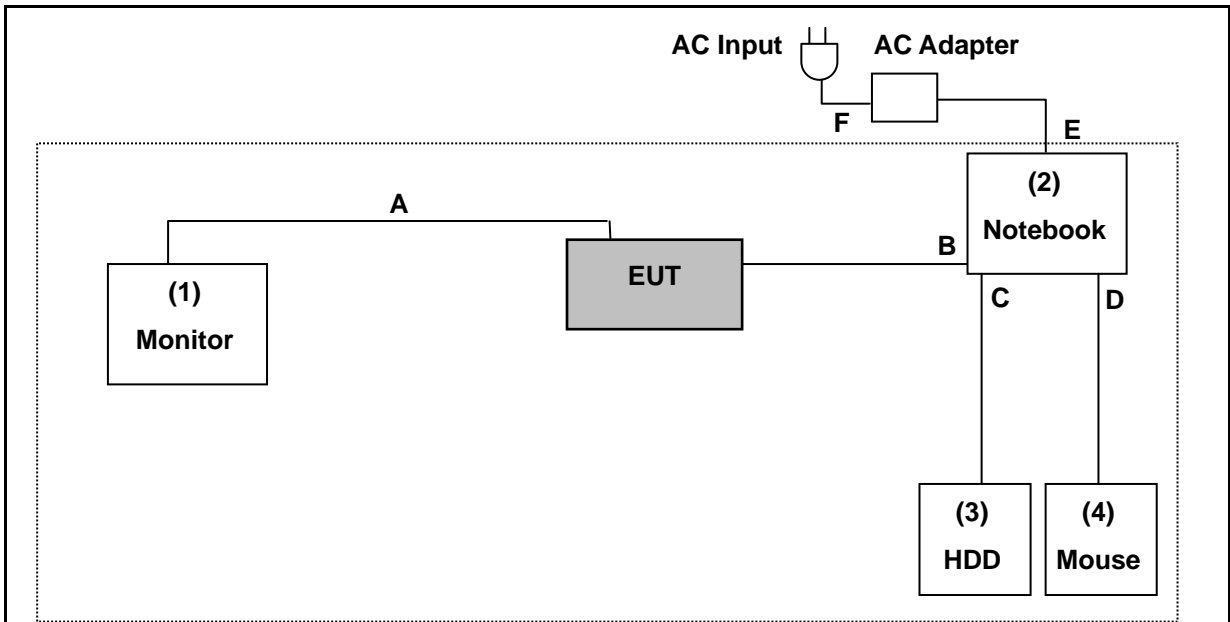

Signal Cable Type		Signal Cable Description
A	D-SUB Cable	Shielded, 1.8 m with two cores
B	USB Cable	Shielded, 0.6 m
C	USB Cable	Shielded, 2.0 m
D	USB Cable	Shielded, 1.8 m
E	DC Power Cable	Non-Shielded, 1.8 m
F	AC Power Cable	Non-Shielded, 2.0m

Devices Description					
	Product	Manufacturer	Model Number	Serial Number	Power Cord
(1)	LCD Monitor	DELL	U2410f	CN-0J257M-72872-08J-060L	Non-Shielded, 1.8 m
(2)	Notebook	DELL	D531	CN-OXM006-48643-87A-3398	Non-Shielded, 2.0m
(3)	HDD	Buffalo	HD-HXU3	15564891205422	Non-Shielded, 1.5m
(4)	Mouse	Logitech	M-UAG96B	PID-LZ815AA	Power by Notebook

Radiated Emission

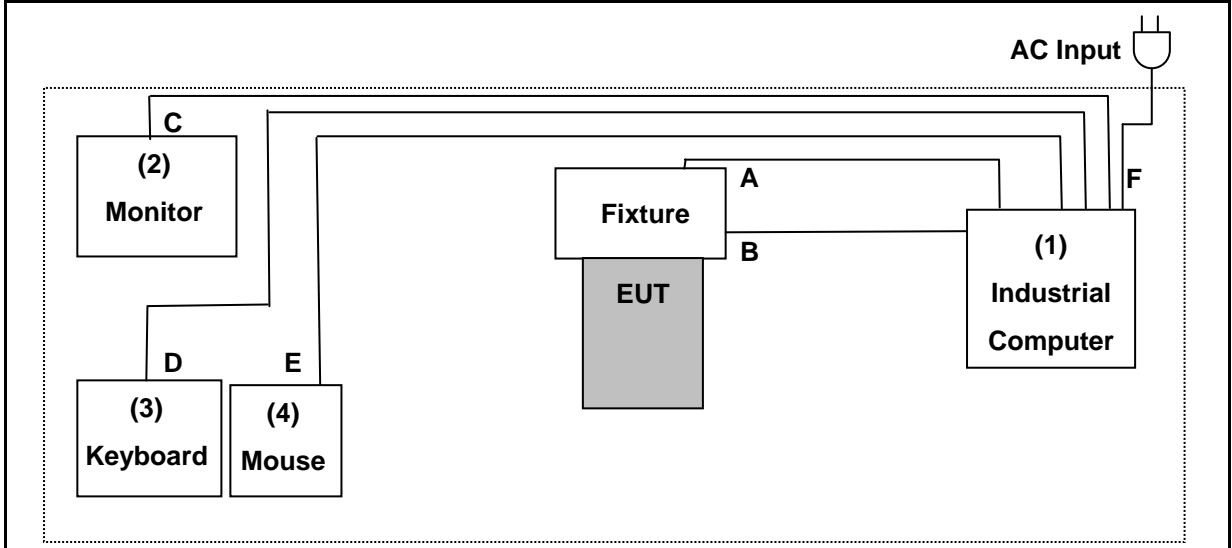

Signal Cable Type		Signal Cable Description
A	Printer Cable	Shielded, 1.9 m
B	USB Cable	Shielded, 1.0 m
C	D-SUB Cable	Shielded, 1.8 m with two cores
D	USB Cable	Shielded, 1.8 m
E	USB Cable	Shielded, 1.8 m
F	AC Power Cable	Non-Shielded, 1.8m

Devices Description					
	Product	Manufacturer	Model Number	Serial Number	Power Cord
(1)	Industrial Computer	ADVANTECH	610H	TBA6080104	Non-Shielded, 1.8m
(2)	LCD Monitor	DELL	G2410T	CN-0N001K-74445-96D-256U	Non-Shielded, 1.8m
(3)	Keyboard	DELL	L100	MY-0DJ325-71619-71B-1197	Power by Industrial Computer
(4)	Mouse	Logitech	M-UAG96B	PID-LZ815AA	Power by Industrial Computer

3.4. Test Site Environment

Items	Required (IEC 68-1)	Actual
Temperature (°C)	15-35	26
Humidity (%RH)	25-75	60
Barometric pressure (mbar)	860-1060	950

4 Conducted Emission Measurement

4.1. Limit

Frequency (MHz)	Quasi-peak	Average
0.15 - 0.5	66 to 56	56 to 46
0.50 - 5.0	56	46
5.0 - 30.0	60	50

4.2. Test Instruments

Describe	Manufacturer	Model Number	Serial Number	Cal. Date	Remark
Test Receiver	R&S	ESCI	100367	06/30/2011	(1)
LISN	R&S	ENV216	101040	03/07/2012	(1)
LISN	R&S	ENV216	101041	03/07/2012	(1)
Test Site	ATL	TE05	TE05	N.C.R.	-----

Remark: (1) Calibration period 1 year. (2) Calibration period 2 years.

NOTE: N.C.R. = No Calibration Request.

4.3. Test Setup

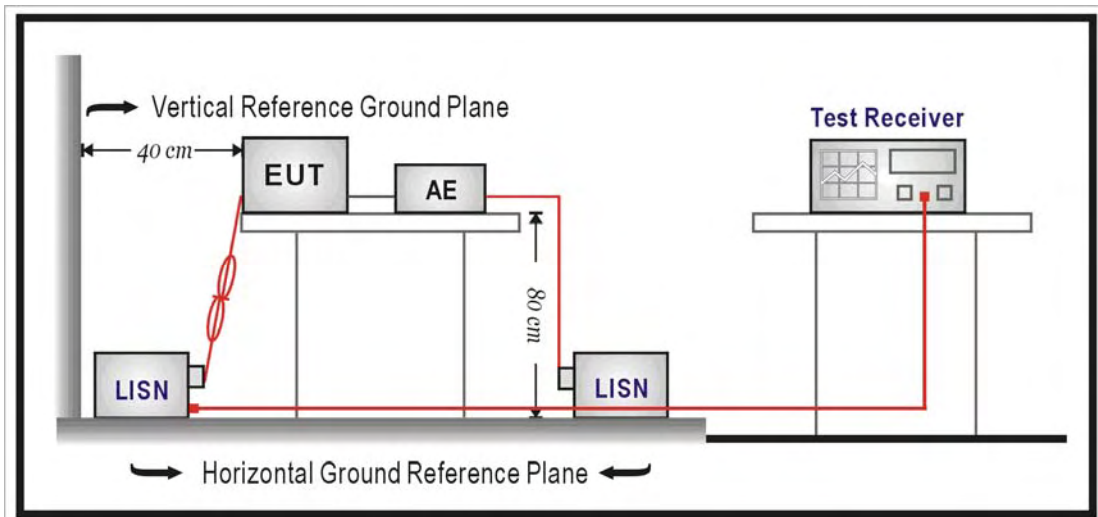

4.4. Test Procedure

The power line conducted emission measurements were performed in a shielded enclosure. The EUT was assembled on a wooden table which is 80 centimeters high, was placed 40 centimeters from the back wall and at least 1 meter from the sidewall.

Power was fed to the EUT from the public utility power grid through a line filter and EMCO Model 3162/2 SH Line Impedance Stabilization Networks (LISN). The LISN housing, measuring instrumentation case, ground plane, etc., were electrically bonded together at the same RF potential. The Spectrum analyzer was connected to the AC line through an isolation transformer. The 50-ohm output of the LISN was connected to the spectrum analyzer directly. Conducted emission levels were in the CISPR quasi-peak detection mode. The analyzer's 6 dB bandwidth was set to 9 KHz. No post-detector video filter was used.

The spectrum was scanned from 150 KHz to 30 MHz. The physical arrangement of the test system and associated cabling was varied (within the scope of arrangements likely to be encountered in actual use) to determine the effect on the unit's emanations in amplitude and frequency. All spurious emission frequencies were observed. The highest emission amplitudes relative to the appropriate limit were measured and have been recorded in paragraph 4.1.

4.5. Test Result

Standard:	FCC Part 15C	Line:	L1
Test item:	Conducted Emission	Power:	AC 120V/60Hz
Model Number:	ID-80125001-001	Temp.(°C)/Hum.(%RH):	22(°C)/59%RH
Mode:	Mode 1	Date:	03/22/2012
		Test By:	Fly Lu
Description:			

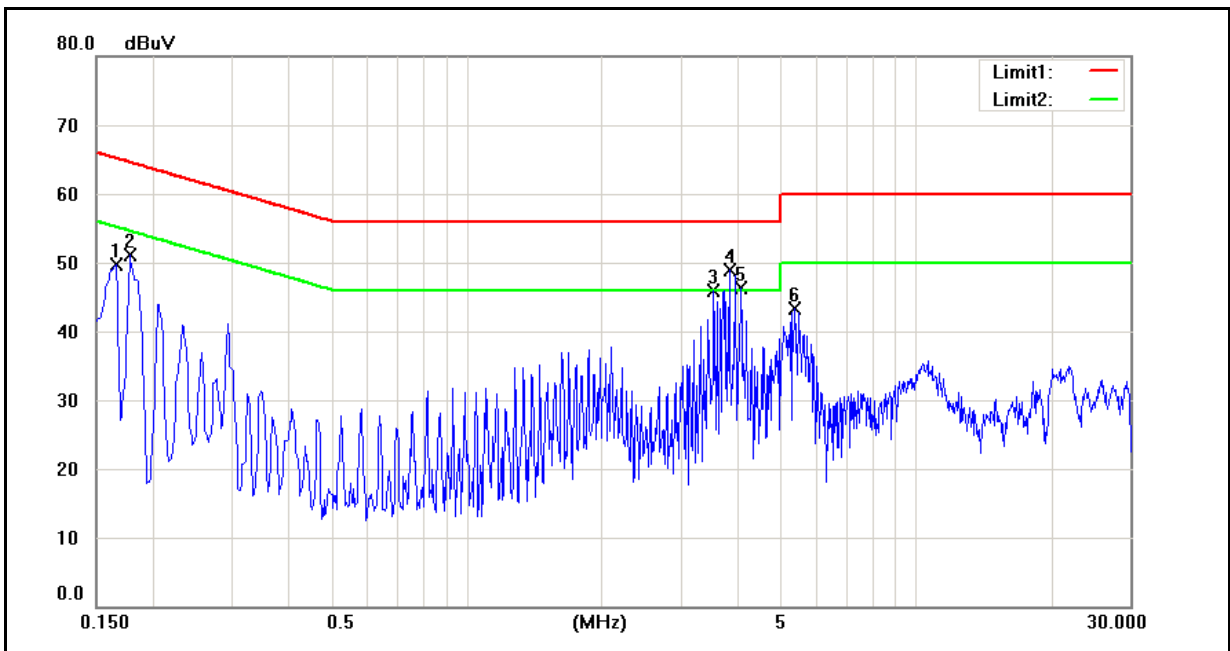

No.	Frequency (MHz)	QP reading (dBuV)	AVG reading (dBuV)	Correction factor (dB)	QP result (dBuV)	AVG result (dBuV)	QP limit (dBuV)	AVG limit (dBuV)	QP margin (dB)	AVG margin (dB)	Remark
1	0.1660	32.21	12.52	9.65	41.86	22.17	65.16	55.16	-23.30	-32.99	Pass
2	0.1780	41.19	28.83	9.65	50.84	38.48	64.58	54.58	-13.74	-16.10	Pass
3	3.5620	32.47	18.99	9.75	42.22	28.74	56.00	46.00	-13.78	-17.26	Pass
4	3.8540	36.89	23.26	9.73	46.62	32.99	56.00	46.00	-9.38	-13.01	Pass
5	4.0860	32.95	20.61	9.71	42.66	30.32	56.00	46.00	-13.34	-15.68	Pass
6	5.3780	28.90	15.82	9.72	38.62	25.54	60.00	50.00	-21.38	-24.46	Pass

Standard:	FCC Part 15C	Line:	N
Test item:	Conducted Emission	Power:	AC 120V/60Hz
Model Number:	ID-80125001-001	Temp.(°C)/Hum.(%RH):	22(°C)/59%RH
Mode:	Mode 1	Date:	03/22/2012
		Test By:	Fly Lu
Description:			

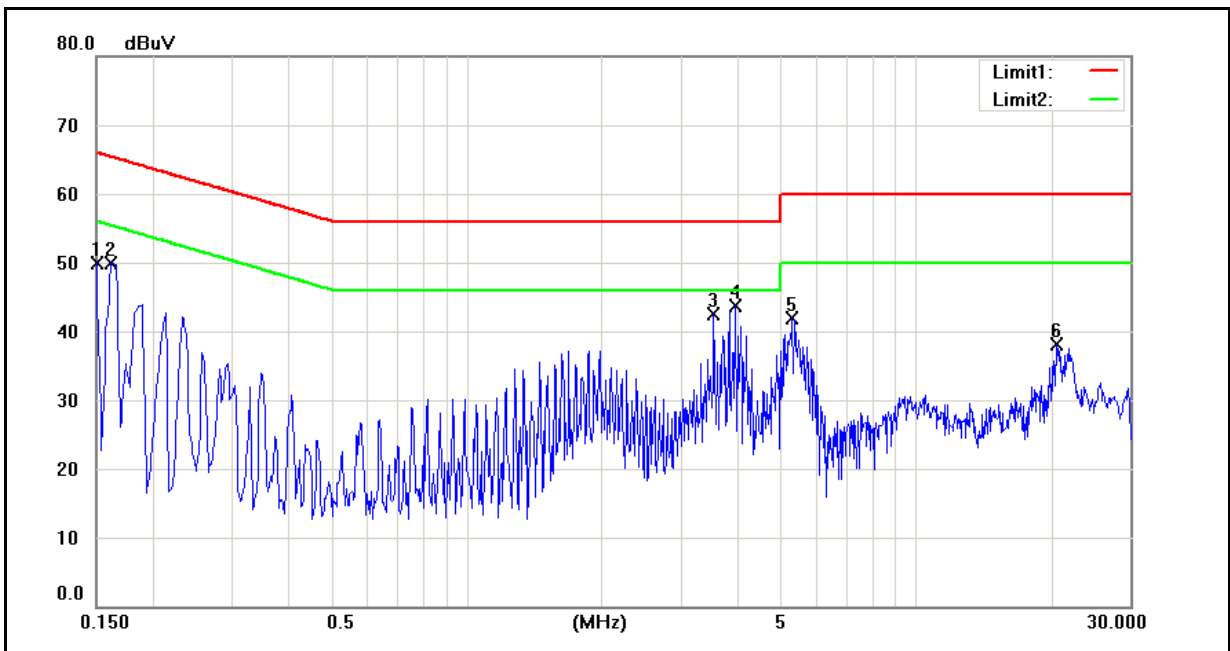

No.	Frequency (MHz)	QP reading (dBuV)	AVG reading (dBuV)	Correction factor (dB)	QP result (dBuV)	AVG result (dBuV)	QP limit (dBuV)	AVG limit (dBuV)	QP margin (dB)	AVG margin (dB)	Remark
1	0.1500	32.42	13.89	9.65	42.07	23.54	66.00	56.00	-23.93	-32.46	Pass
2	0.1620	32.79	8.82	9.65	42.44	18.47	65.36	55.36	-22.92	-36.89	Pass
3	3.5620	27.03	17.82	9.75	36.78	27.57	56.00	46.00	-19.22	-18.43	Pass
4	3.9700	31.69	20.21	9.72	41.41	29.93	56.00	46.00	-14.59	-16.07	Pass
5	5.3100	30.33	20.97	9.71	40.04	30.68	60.00	50.00	-19.96	-19.32	Pass
6	20.5500	23.87	18.02	9.84	33.71	27.86	60.00	50.00	-26.29	-22.14	Pass

5 Radiated Interference Measurement

5.1. Limit

According to §15.209(a), except as provided elsewhere in this subpart, the emissions from an intentional radiator shall not exceed the field strength levels specified in the following table:

Frequency (MHz)	Field Strength ($\mu\text{V}/\text{m}$ at meter)	Measurement Distance (meters)
0.009 – 0.490	2400 / F (kHz)	300
0.490 – 1.705	24000 / F (kHz)	30
1.705 – 30.0	30	30
30 - 88	100**	3
88-216	150**	3
216-960	200**	3
Above 960	500	3

** Except as provided in paragraph (g), fundamental emissions from intentional radiators operating under this Section shall not be located in the frequency bands 54-72 MHz, 76-88 MHz, 174-216 MHz or 470-806 MHz. However, operation within these frequency bands is permitted under other sections of this Part, e.g., Sections 15.231 and 15.241.

5.2. Test Instruments

3 Meter Chamber					
Equipment	Manufacturer	Model Number	Serial Number	Cal. Date	Remark
RF Pre-selector	Agilent	N9039A	MY46520256	01/16/2012	(1)
Spectrum Analyzer	Agilent	E4446A	MY46180578	01/16/2012	(1)
Pre Amplifier	Agilent	8449B	3008A02237	02/22/2012	(1)
Pre Amplifier	Agilent	8447D	2944A10961	02/22/2012	(1)
Broadband Antenna (30MHz~1GHz)	SCHWARZBECK MESS-ELEKTRONIK	VULB9163	9163-270	07/29/2011	(1)
Horn Antenna (1~18GHz)	SCHWARZBECK MESS-ELEKTRONIK	BBHA9120D	9120D-550	06/29/2011	(1)
Horn Antenna (18~40GHz)	SCHWARZBECK MESS-ELEKTRONIK	BBHA9170	9170-320	06/28/2011	(1)
Test Site	ATL	TE01	888001	12/20/2011	(1)

Remark: (1) Calibration period 1 year. (2) Calibration period 2 years. (3) Calibration period 3 years.

NOTE: N.C.R. = No Calibration Request.

5.3. Setup

Below 1GHz

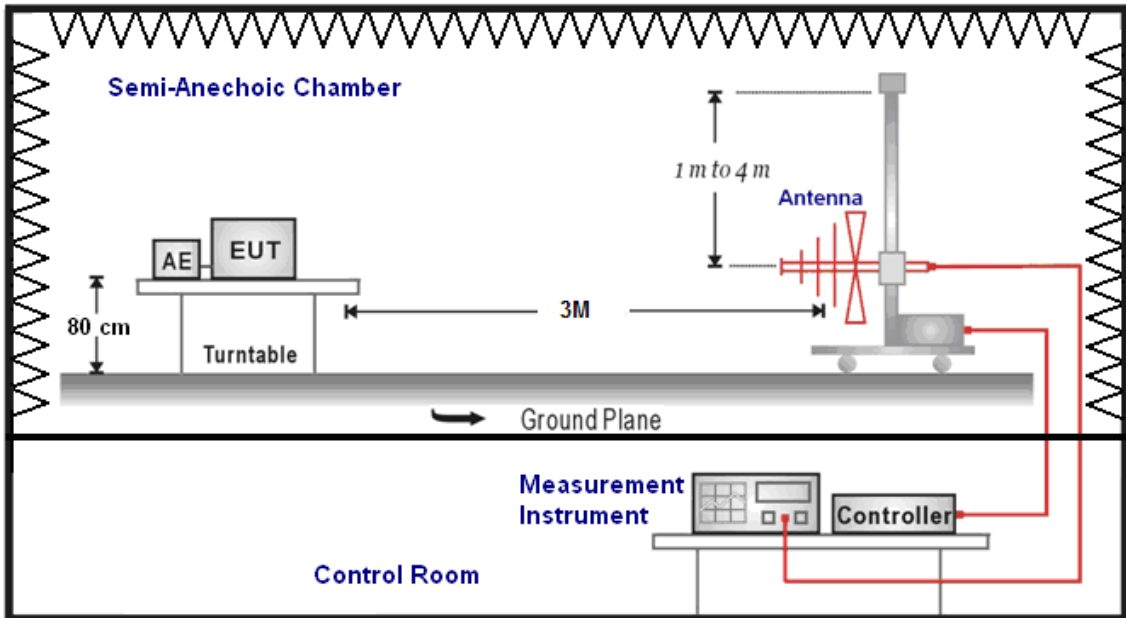

Above 1GHz

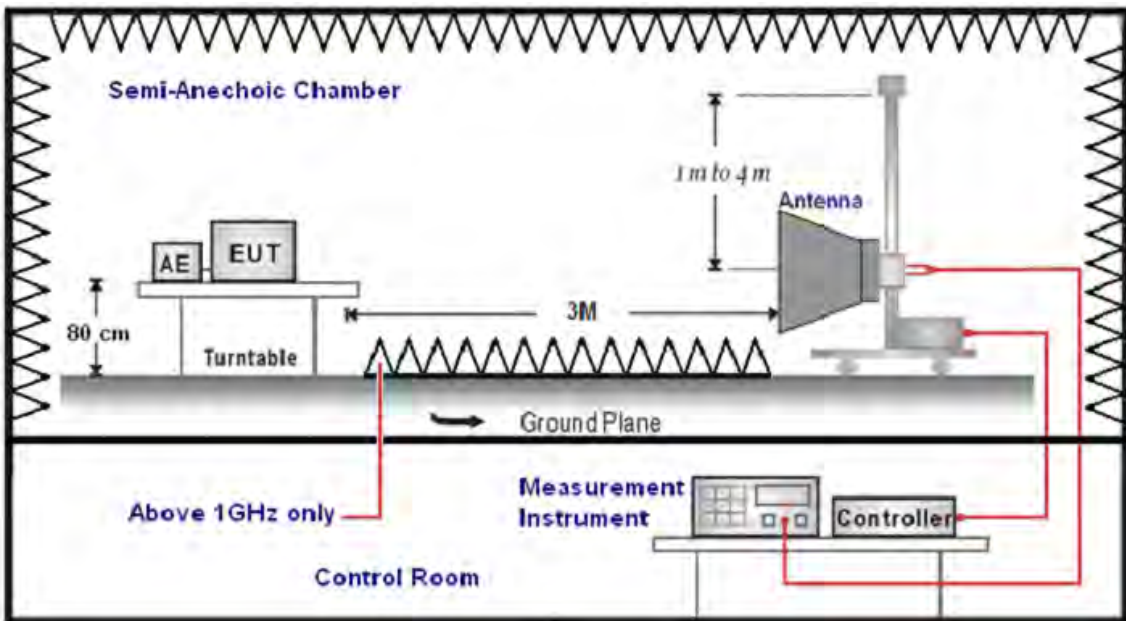

5.4. Test Procedure

Final radiation measurements were made on a three-meter, Semi Anechoic Chamber. The EUT system was placed on a nonconductive turntable which is 0.8 meters height, top surface 1.0 x 1.5 meter. The spectrum was examined from 250 MHz to 2.5 GHz in order to cover the whole spectrum below 10th harmonic which could generate from the EUT. During the test, EUT was set to transmit continuously & Measurements spectrum range from 9 kHz to 26.5 GHz is investigated.

For measurements below 1 GHz the resolution bandwidth is set to 100 kHz for peak detection measurements or 120 kHz for quasi-peak detection measurements. Peak detection is used unless otherwise noted as quasi-peak.

For measurements above 1 GHz the resolution bandwidth is set to 1 MHz, and then the video bandwidth is set to 1 MHz for peak measurements and 10 Hz for average measurements.

A nonconductive material surrounded the EUT to supporting the EUT for standing on three orthogonal planes. At each condition, the EUT was rotated 360 degrees, and the antenna was raised and lowered from one to four meters to find the maximum emission levels. Measurements were taken using both horizontal and vertical antenna polarization.

SCHWARZBECK MESS-ELEKTRONIK Biconilog Antenna (mode VULB9163) at 3 Meter and the SCHWARZBECK Double Ridged Guide Antenna (model BBHA9120D&9170) was used in frequencies 1 – 26.5 GHz at a distance of 1 meter. All test results were extrapolated to equivalent signal at 3 meters utilizing an inverse linear distance extrapolation Factor (20dB/decade).

For testing above 1GHz, the emission level of the EUT in peak mode was 20dB lower than average limit (that means the emission level in peak mode also complies with the limit in average mode), then testing will be stopped and peak values of EUT will be reported, otherwise, the emissions will be measured in average mode again and reported.

Appropriate preamplifiers were used for improving sensitivity and precautions were taken to avoid overloading or desensitizing the spectrum analyzer. No post – detector video filters were used in the test.

The spectrum analyzer's 6 dB bandwidth was set to 1 MHz, and the analyzer was operated in the peak detection mode, for frequencies both below and up 1 GHz. The average levels were obtained by subtracting the duty cycle correction factor from the peak readings.

The following procedures were used to convert the emission levels measured in decibels referenced to 1 microvolt (dBuV) into field intensity in micro volts pre meter (uV/m).

The actual field intensity in decibels referenced to 1 microvolt in to field intensity in micro volts per meter (dBuV/m).

The actual field intensity in referenced to 1 microvolt per meter (dBuV/m) is determined by algebraically adding the measured reading in dBuV, the antenna factor (dB), and cable loss (dB) and Subtracting the gain of preamplifier (dB) is auto calculate in spectrum analyzer.

(1) $\text{Amplitude (dBuV/m)} = \text{FI (dBuV)} + \text{AF (dBuV)} + \text{CL (dBuV)} - \text{Gain (dB)}$

FI= Reading of the field intensity.

AF= Antenna factor.

CL= Cable loss.

P.S Amplitude is auto calculate in spectrum analyzer.

(2) $\text{Actual Amplitude (dBuV/m)} = \text{Amplitude (dBuV)} - \text{Dis (dB)}$

The FCC specified emission limits were calculated according the EUT operating frequency and by following linear interpolation equations:

(a) For fundamental frequency : Transmitter Output < +30dBm

(b) For spurious frequency : Spurious emission limits = fundamental emission limit /10

5.5. Test Result

Below 1GHz

Standard:	FCC Part 15C	Test Distance:	3m
Test item:	Radiated Emission	Power:	AC 120V/60Hz
Model Number:	ID-80125001-001	Temp.(°C)/Hum.(%RH):	26(°C)/60%RH
Mode:	Mode 1	Date:	03/28/2012
Ant.Polar.:	Horizontal	Test By:	Fly Lu

No.	Frequency (MHz)	Reading (dBuV)	Correct Factor(dB/m)	Result (dBuV/m)	Limit (dBuV/m)	Margin (dB)	Remark
1	144.0000	49.54	-17.23	32.31	43.50	-11.19	QP
2	250.0000	45.59	-11.95	33.64	46.00	-12.36	QP
3	398.0000	41.64	-8.70	32.94	46.00	-13.06	QP
4	553.0000	38.94	-6.28	32.66	46.00	-13.34	QP
5	720.0000	34.33	-2.96	31.37	46.00	-14.63	QP
6	929.0000	29.62	0.66	30.28	46.00	-15.72	QP

Standard:	FCC Part 15C	Test Distance:	3m
Test item:	Radiated Emission	Power:	AC 120V/60Hz
Model Number:	ID-80125001-001	Temp.(°C)/Hum.(%RH):	26(°C)/60%RH
Mode:	Mode 1	Date:	03/28/2012
Ant.Polar.:	Vertical	Test By:	Fly Lu

No.	Frequency (MHz)	Reading (dBuV)	Correct Factor(dB/m)	Result (dBuV/m)	Limit (dBuV/m)	Margin (dB)	Remark
1	144.0000	49.01	-17.23	31.78	43.50	-11.72	QP
2	241.5000	45.64	-12.11	33.53	46.00	-12.47	QP
3	343.5000	41.44	-9.01	32.43	46.00	-13.57	QP
4	553.0000	37.04	-6.28	30.76	46.00	-15.24	QP
5	676.0000	35.85	-3.78	32.07	46.00	-13.93	QP
6	933.0000	29.23	0.72	29.95	46.00	-16.05	QP

Note: No emission found between lowest internal used/generated frequency to 30MHz (9kHz~30MHz).

Above 1GHz

Standard:	FCC Part 15C			Test Distance:	3m		
Test item:	Radiated Emission			Power:	AC 120V/60Hz		
Model Number:	ID-80125001-001			Temp.(°C)/Hum.(%RH):	26(°C)/60%RH		
Mode:	Mode 2			Date:	03/28/2012		
Frequency:	2402 MHz			Test By:	Fly Lu		
Frequency (MHz)	Reading (dBuV)	Correct Factor(dB/m)	Result (dBuV/m)	Limit (dBuV/m)	Margin (dB)	Remark	Ant.Polar. H / V
3142.000	39.19	2.52	41.71	74.00	-32.29	peak	H
4804.000	47.92	7.90	55.82	74.00	-18.18	peak	H
4804.000	41.24	7.90	49.14	54.00	-4.86	AVG	H
6145.000	35.12	11.50	46.62	74.00	-27.38	peak	H
2463.000	41.13	0.27	41.40	74.00	-32.60	peak	V
4804.000	45.84	7.90	53.74	74.00	-20.26	peak	V
4804.000	41.05	7.90	48.95	54.00	-5.05	AVG	V
6271.000	34.73	12.07	46.80	74.00	-27.20	peak	V

Standard:	FCC Part 15C			Test Distance:	3m		
Test item:	Radiated Emission			Power:	AC 120V/60Hz		
Model Number:	ID-80125001-001			Temp.(°C)/Hum.(%RH):	26(°C)/60%RH		
Mode:	Mode 2			Date:	03/28/2012		
Frequency:	2441 MHz			Test By:	Fly Lu		
Frequency (MHz)	Reading (dBuV)	Correct Factor(dB/m)	Result (dBuV/m)	Limit (dBuV/m)	Margin (dB)	Remark	Ant.Polar. H / V
3156.000	38.89	2.54	41.43	74.00	-32.57	peak	H
4882.000	47.23	8.14	55.37	74.00	-18.63	peak	H
4882.000	39.83	8.14	47.97	54.00	-6.03	AVG	H
6222.000	35.34	11.85	47.19	74.00	-26.81	peak	H
3009.000	39.20	2.22	41.42	74.00	-32.58	peak	V
4882.000	45.81	8.14	53.95	74.00	-20.05	peak	V
4882.000	40.68	8.14	48.82	54.00	-5.18	AVG	V
6376.000	34.30	12.53	46.83	74.00	-27.17	peak	V

Standard:	FCC Part 15C			Test Distance:	3m		
Test item:	Radiated Emission			Power:	AC 120V/60Hz		
Model Number:	ID-80125001-001			Temp.(°C)/Hum.(%RH):	26(°C)/60%RH		
Mode:	Mode 2			Date:	03/28/2012		
Frequency:	2480 MHz			Test By:	Fly Lu		
Frequency (MHz)	Reading (dBuV)	Correct Factor(dB/m)	Result (dBuV/m)	Limit (dBuV/m)	Margin (dB)	Remark	Ant.Polar. H / V
3359.000	39.23	3.00	42.23	74.00	-31.77	peak	H
4960.000	45.12	8.37	53.49	74.00	-20.51	peak	H
4960.000	38.77	8.37	47.14	54.00	-6.86	AVG	H
6327.000	35.54	12.32	47.86	74.00	-26.14	peak	H
3128.000	39.28	2.49	41.77	74.00	-32.23	peak	V
4960.000	44.75	8.37	53.12	74.00	-20.88	peak	V
4960.000	40.16	8.37	48.53	54.00	-5.47	AVG	V
6544.000	34.80	13.24	48.04	74.00	-25.96	peak	V

Standard:	FCC Part 15C			Test Distance:	3m			
Test item:	Radiated Emission			Power:	AC 120V/60Hz			
Model Number:	ID-80125001-001			Temp.(°C)/Hum.(%RH):	26(°C)/60%RH			
Mode:	Mode 3			Date:	03/28/2012			
Frequency:	2441 MHz			Test By:	Fly Lu			
Frequency (MHz)	Reading (dBuV)	Correct Factor(dB/m)	Result (dBuV/m)	Peak Limit (dBuV/m)	AVG. Limit (dBuV/m)	Margin (dB)	Remark	Ant.Polar. H / V
2029.000	39.53	-1.66	37.87	74.00	54.00	-36.13	peak	H
4444.000	37.42	6.77	44.19	74.00	54.00	-29.81	peak	H
6334.000	35.62	12.35	47.97	74.00	54.00	-26.03	peak	H
3072.000	38.19	2.36	40.55	74.00	54.00	-33.45	peak	V
4682.000	36.42	7.52	43.94	74.00	54.00	-30.06	peak	V
5900.000	34.77	10.69	45.46	74.00	54.00	-28.54	peak	V

6 Maximum Conducted Output Power Measurement

6.1. Limit

For frequency hopping systems operating in the 2400–2483.5 MHz band employing at least 75 non-overlapping hopping channels < 1 watt.

6.2. Test Setup

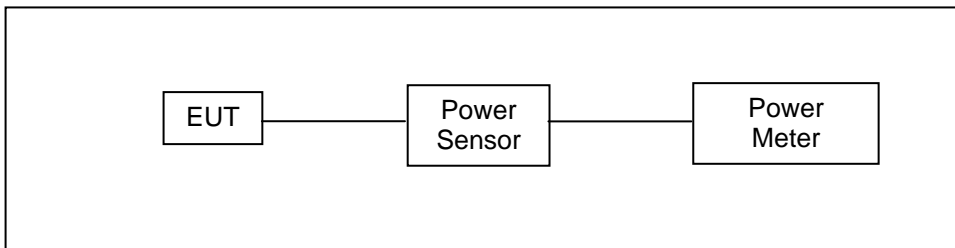

6.3. Test Instruments

Equipment	Manufacturer	Model Number	Serial Number	Cal. Date	Remark
Single Channel PK Power Sensor	Agilent	N1911A	MY45101619	12/15/2011	(1)
Wideband Power Meter	Agilent	N1921A	MY45241957	12/15/2011	(1)
Test Site	ATL	TE02	TE02	N.C.R.	-----

Remark: (1) Calibration period 1 year. (2) Calibration period 2 years.

NOTE: N.C.R. = No Calibration Request.

6.4. Test Procedure

The tests below are run with the EUT's transmitter set at high power in TX mode. The EUT is needed to force selection of output power level and channel number. While testing, EUT was set to transmit continuously. Remove the Subjective device's antenna and connect the RF output port to power sensor. The maximum peak output power shall not exceed 1 watt.

Use a direct connection between the antenna port of transmitter and the power sensor, for prevent the power sensor input attenuation 40-50 dB. Set the RBW Bandwidth of the emission or use a channel power meter mode.

For antennas with gains of 6 dBi or less, maximum allowed transmitter output is 1 watt (+30 dBm). For antennas with gains greater than 6 dBi, transmitter output level must be decreased by an amount equal to (GAIN - 6)/3 dBm.

The antenna port of the EUT was connected to the input of a power sensor. Power was read directly and cable loss correction was added to the reading to obtain power at the EUT antenna terminals.

6.5. Test Result

Model Number	ID-80125001-001					
Test Item	Maximum Conducted Output Power					
Test Mode	Mode 2: GFSK Link Mode					
Date of Test	03/27/2012			Test Site	TE02	
Frequency (MHz)	Packet Type	Average Power		Peak Power		Limit (W)
		(dBm)	(W)	(dBm)	(W)	
2402	DH1	-2.82	0.00052	2.29	0.00169	< 1
	DH3	0.26	0.00106	2.31	0.00170	< 1
	DH5	0.90	0.00123	2.40	0.00174	< 1
2441	DH1	-4.03	0.00040	1.18	0.00131	< 1
	DH3	-0.92	0.00081	1.20	0.00132	< 1
	DH5	-0.27	0.00094	1.28	0.00134	< 1
2480	DH1	-5.40	0.00029	-0.36	0.00092	< 1
	DH3	-2.25	0.00060	-0.33	0.00093	< 1
	DH5	-1.59	0.00069	-0.31	0.00093	< 1

7 Minimum 20dB RF Bandwidth Measurement

7.1. Limit

N/A

7.2. Test Setup

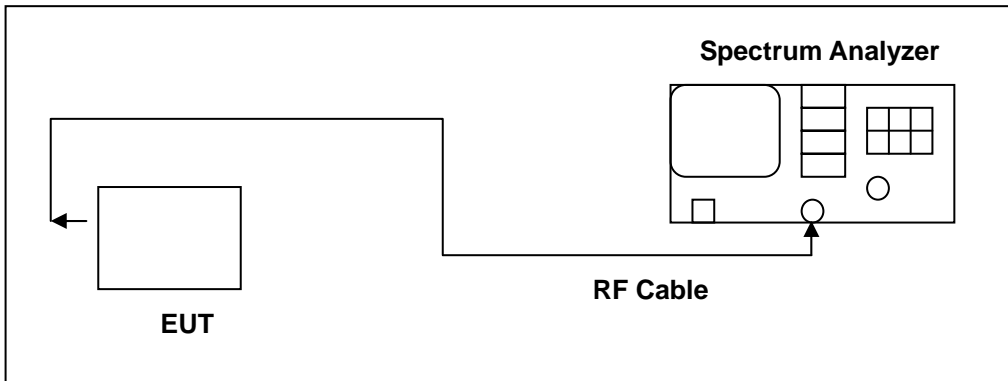

7.3. Test Instruments

Equipment	Manufacturer	Model Number	Serial Number	Cal. Date	Remark
Spectrum Analyzer	Agilent	E4445A	MY45300744	12/20/2011	(1)
Test Site	ATL	TE02	TE02	N.C.R.	-----

Remark: (1) Calibration period 1 year. (2) Calibration period 2 years.

NOTE: N.C.R. = No Calibration Request.

7.4. Test Procedure

The RF output port of the Equipment-Under-Test is directly coupled to the input of the EMC analyzer through a specialized RF connector and a 10dB passive attenuator. A fully charged battery was used for the supply voltage. The Bluetooth frequency hopping function of the EUT was enabled. The spectrum analyzer used the following settings:

1. Span = approx. 2 to 3 times the 20dB bandwidth, centered on a hopping frequency
2. RBW \geq 1% of the 20dB span
3. VBW \geq RBW
4. Sweep = auto
5. Detector function = peak
6. Trace = max hold

The trace was allowed to stabilize. The EUT was transmitting at its maximum data rate. The marker-to-peak function was used to set the marker to the peak of the emission. The marker-delta function was used to measure 20dB down one side of the emission. The marker-delta function and marker was moved to the other side of the emission until it was even with the reference marker. The marker-delta reading at this point was the 20dB bandwidth of the emission.

7.5. Test Result

Model Number	ID-80125001-001		
Test Item	Minimum 20dB RF Bandwidth		
Test Mode	Mode 2: GFSK Link Mode		
Date of Test	03/27/2012	Test Site	TE02
Frequency (MHz)	Measurement (MHz)	Limit (MHz)	
2402	0.930	-----	
2441	0.933	-----	
2480	0.932	-----	

7.6. Test Graphs

Mode 2: GFSK Link Mode																					
2402	<p>Agilent R T Freq/Channel</p> <p>Ref 20 dBm Atten 30 dB Mkr2 930 kHz -0.68 dB</p> <p>#Peak</p> <p>Log</p> <p>10</p> <p>dB/</p> <p>Offst</p> <p>0.5</p> <p>dB</p> <p>DI</p> <p>-22.3</p> <p>dBm</p> <p>LgAv</p> <p>Center 2.402 000 GHz Span 1.5 MHz</p> <p>#Res BW 10 kHz #VBW 30 kHz Sweep 14.36 ms (601 pts)</p> <table border="1"> <thead> <tr> <th>Marker</th> <th>Trace</th> <th>Type</th> <th>X Axis</th> <th>Amplitude</th> </tr> </thead> <tbody> <tr> <td>1</td> <td>(1)</td> <td>Freq</td> <td>2.402 046 GHz</td> <td>-2.33 dBm</td> </tr> <tr> <td>2R</td> <td>(1)</td> <td>Freq</td> <td>2.401 534 GHz</td> <td>-22.35 dBm</td> </tr> <tr> <td>2a</td> <td>(1)</td> <td>Freq</td> <td>930 kHz</td> <td>-0.68 dB</td> </tr> </tbody> </table> <p>Copyright 2000-2005 Agilent Technologies</p>	Marker	Trace	Type	X Axis	Amplitude	1	(1)	Freq	2.402 046 GHz	-2.33 dBm	2R	(1)	Freq	2.401 534 GHz	-22.35 dBm	2a	(1)	Freq	930 kHz	-0.68 dB
Marker	Trace	Type	X Axis	Amplitude																	
1	(1)	Freq	2.402 046 GHz	-2.33 dBm																	
2R	(1)	Freq	2.401 534 GHz	-22.35 dBm																	
2a	(1)	Freq	930 kHz	-0.68 dB																	
2441	<p>Agilent R T Freq/Channel</p> <p>Ref 20 dBm Atten 30 dB Mkr2 933 kHz -0.94 dB</p> <p>#Peak</p> <p>Log</p> <p>10</p> <p>dB/</p> <p>Offst</p> <p>0.5</p> <p>dB</p> <p>DI</p> <p>-23.5</p> <p>dBm</p> <p>LgAv</p> <p>Center 2.441 000 GHz Span 1.5 MHz</p> <p>#Res BW 10 kHz #VBW 30 kHz Sweep 14.36 ms (601 pts)</p> <table border="1"> <thead> <tr> <th>Marker</th> <th>Trace</th> <th>Type</th> <th>X Axis</th> <th>Amplitude</th> </tr> </thead> <tbody> <tr> <td>1</td> <td>(1)</td> <td>Freq</td> <td>2.441 005 GHz</td> <td>-3.51 dBm</td> </tr> <tr> <td>2R</td> <td>(1)</td> <td>Freq</td> <td>2.440 531 GHz</td> <td>-23.68 dBm</td> </tr> <tr> <td>2a</td> <td>(1)</td> <td>Freq</td> <td>933 kHz</td> <td>-0.94 dB</td> </tr> </tbody> </table> <p>Copyright 2000-2005 Agilent Technologies</p>	Marker	Trace	Type	X Axis	Amplitude	1	(1)	Freq	2.441 005 GHz	-3.51 dBm	2R	(1)	Freq	2.440 531 GHz	-23.68 dBm	2a	(1)	Freq	933 kHz	-0.94 dB
Marker	Trace	Type	X Axis	Amplitude																	
1	(1)	Freq	2.441 005 GHz	-3.51 dBm																	
2R	(1)	Freq	2.440 531 GHz	-23.68 dBm																	
2a	(1)	Freq	933 kHz	-0.94 dB																	
2480	<p>Agilent R T Freq/Channel</p> <p>Ref 20 dBm Atten 30 dB Mkr2 932 kHz -0.02 dB</p> <p>#Peak</p> <p>Log</p> <p>10</p> <p>dB/</p> <p>Offst</p> <p>0.5</p> <p>dB</p> <p>DI</p> <p>-25.0</p> <p>dBm</p> <p>LgAv</p> <p>Center 2.480 000 GHz Span 1.5 MHz</p> <p>#Res BW 10 kHz #VBW 30 kHz Sweep 14.36 ms (601 pts)</p> <table border="1"> <thead> <tr> <th>Marker</th> <th>Trace</th> <th>Type</th> <th>X Axis</th> <th>Amplitude</th> </tr> </thead> <tbody> <tr> <td>1</td> <td>(1)</td> <td>Freq</td> <td>2.479 997 GHz</td> <td>-5.01 dBm</td> </tr> <tr> <td>2R</td> <td>(1)</td> <td>Freq</td> <td>2.479 529 GHz</td> <td>-25.22 dBm</td> </tr> <tr> <td>2a</td> <td>(1)</td> <td>Freq</td> <td>932 kHz</td> <td>-0.02 dB</td> </tr> </tbody> </table> <p>Copyright 2000-2005 Agilent Technologies</p>	Marker	Trace	Type	X Axis	Amplitude	1	(1)	Freq	2.479 997 GHz	-5.01 dBm	2R	(1)	Freq	2.479 529 GHz	-25.22 dBm	2a	(1)	Freq	932 kHz	-0.02 dB
Marker	Trace	Type	X Axis	Amplitude																	
1	(1)	Freq	2.479 997 GHz	-5.01 dBm																	
2R	(1)	Freq	2.479 529 GHz	-25.22 dBm																	
2a	(1)	Freq	932 kHz	-0.02 dB																	

8 Carrier Frequency Separation Measurement

8.1. Limit

Title 47 of the CFR, Part 15 Subpart (c) 15.247(a)(1)(i) requires the measurement of the bandwidth of the transmission between the -20 dB points on the transmitted spectrum. The results of this test determine the limits for channel spacing. The channel spacing shall be a minimum of 25 kHz or the 20 dB bandwidth.

8.2. Test Setup

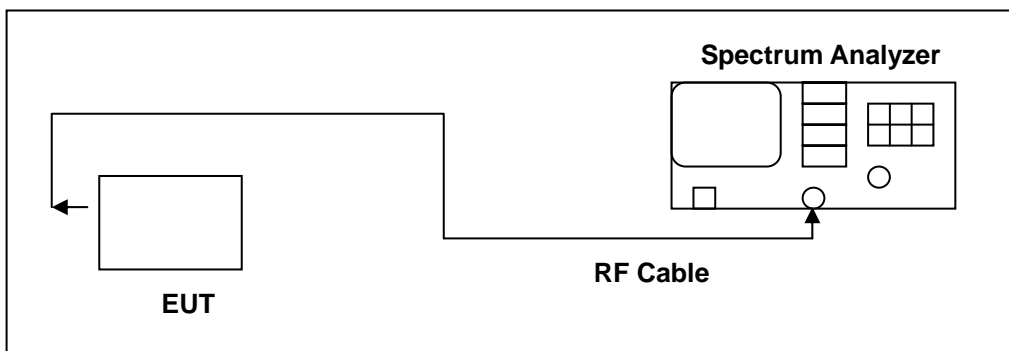

8.3. Test Instruments

Equipment	Manufacturer	Model Number	Serial Number	Cal. Date	Remark
Spectrum Analyzer	Agilent	E4445A	MY45300744	12/20/2011	(1)
Test Site	ATL	TE02	TE02	N.C.R.	-----

Remark: (1) Calibration period 1 year. (2) Calibration period 2 years.

NOTE: N.C.R. = No Calibration Request.

8.4. Test Procedure

The RF output port of the Equipment-Under-Test is directly coupled to the input of the EMC analyzer through a specialized RF connector and a 10dB passive attenuator. A fully charged battery was used for the supply voltage. The Bluetooth transmitter of the V6 had its hopping function enabled. The following spectrum analyzer settings were used:

1. Span = wide enough to capture the peaks of two adjacent channels
2. Resolution (or IF) Bandwidth (RBW) \geq 1% of the span
3. Video (or Average) Bandwidth (VBW) \geq RBW
4. Sweep = auto
5. Detector function = peak
6. Trace = max hold

The trace was allowed to stabilize. The marker-delta function was used to determine the separation between the peaks of the adjacent channels.

8.5. Test Result

Model Number	ID-80125001-001		
Test Item	Carrier Frequency Separation		
Test Mode	Mode 2: GFSK Link Mode		
Date of Test	03/27/2012	Test Site	TE02
Frequency (MHz)	Measurement (MHz)	Limit (MHz)	
2441	1	> 0.622	

8.6. Test Graphs

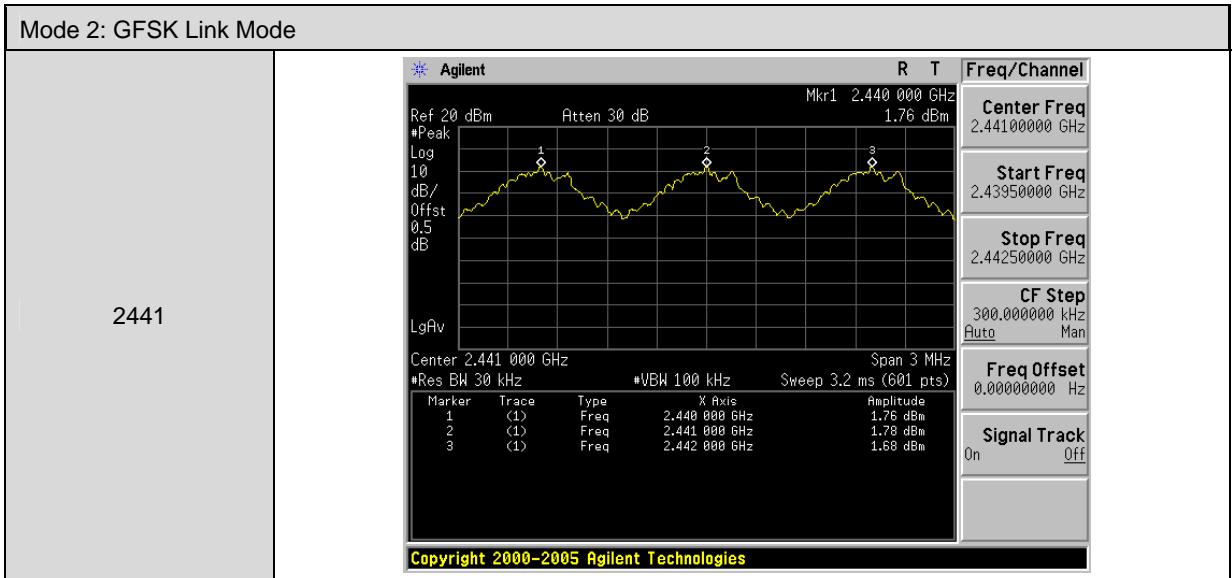

9 Number of Hopping Measurement

9.1. Limit

Frequency hopping systems in the 2400–2483.5 MHz band shall use at least 15 channels.

9.2. Test Setup

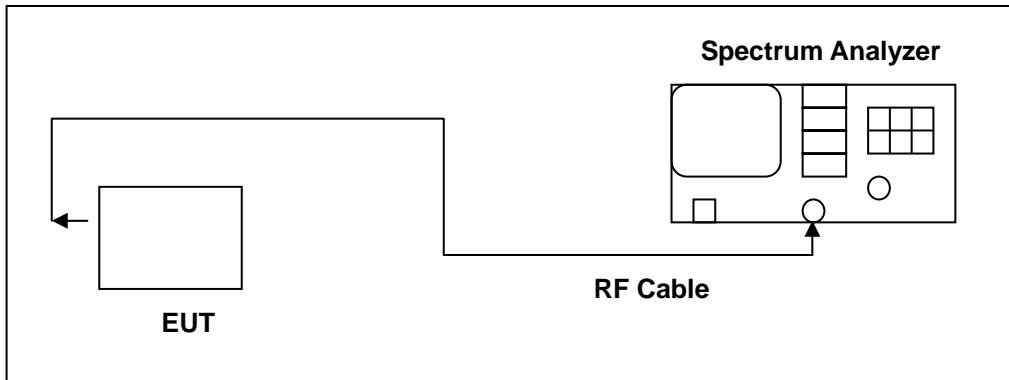

9.3. Test Instruments

Equipment	Manufacturer	Model Number	Serial Number	Cal. Date	Remark
Spectrum Analyzer	Agilent	E4445A	MY45300744	12/20/2011	(1)
Test Site	ATL	TE02	TE02	N.C.R.	-----

Remark: (1) Calibration period 1 year. (2) Calibration period 2 years.

NOTE: N.C.R. = No Calibration Request.

9.4. Test Procedure

The RF output port of the Equipment-Under-Test is directly coupled to the input of the EMC analyzer through a specialized RF connector and a 10dB passive attenuator. A fully charged battery was used for the supply voltage. The Bluetooth frequency hopping function of the EUT was enabled. The spectrum analyzer used the following settings:

1. Span = the frequency band of operation
2. RBW \geq 1% of the span
3. VBW \geq RBW
4. Sweep = auto
5. Detector function = peak
6. Trace = max hold

The trace was allowed to stabilize.

9.5. Test Result

Model Number	ID-80125001-001		
Test Item	Number of Hopping		
Test Mode	Mode 2: GFSK Link Mode		
Date of Test	03/27/2012	Test Site	TE02
Frequency Range (MHz)	Measurement (ch)	Limit (ch)	
2402 - 2480	79	> 15	

9.6. Test Graphs

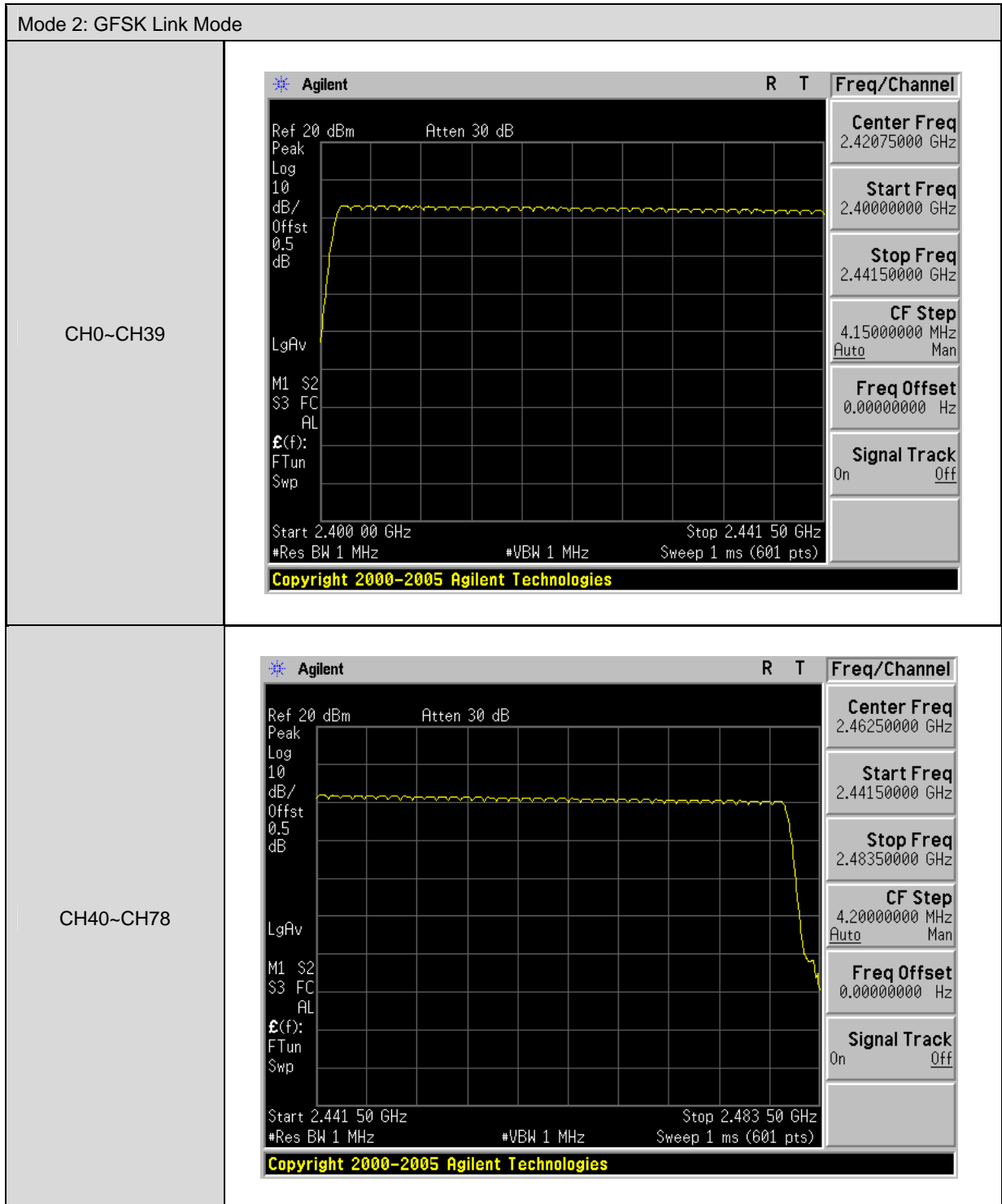

10 Time of Occupancy (Dwell Time) Measurement

10.1.Limit

The average time of occupancy on any channel shall not be greater than 0.4 seconds within a period of 0.4 seconds multiplied by the number of hopping channels employed.

10.2.Test Setup

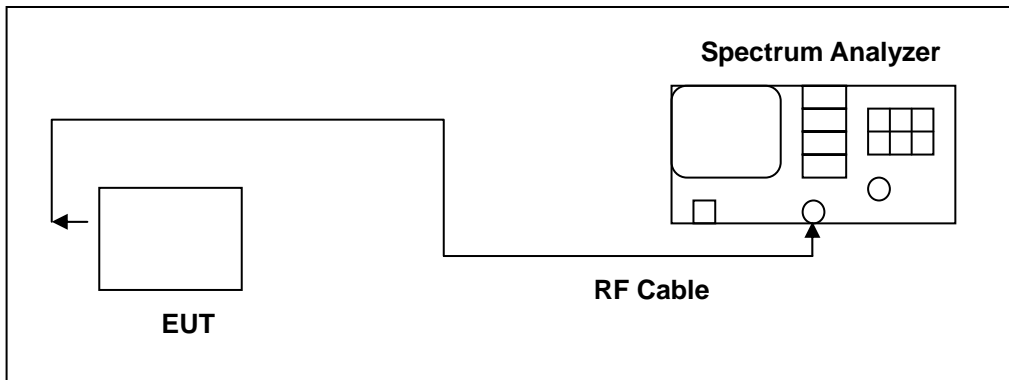

10.3.Test Instruments

Equipment	Manufacturer	Model Number	Serial Number	Cal. Date	Remark
Spectrum Analyzer	Agilent	E4445A	MY45300744	12/20/2011	(1)
Test Site	ATL	TE02	TE02	N.C.R.	-----

Remark: (1) Calibration period 1 year. (2) Calibration period 2 years.

NOTE: N.C.R. = No Calibration Request.

10.4.Test Procedure

The RF output port of the Equipment-Under-Test is directly coupled to the input of the EMC analyzer through a specialized RF connector and a 10dB passive attenuator. A fully charged battery was used for the supply voltage. The Bluetooth hopping function of the EUT was enabled. The following spectrum analyzer settings were used:

1. Span = zero span, centered on a hopping channel
2. RBW = 1 MHz
3. VBW \geq RBW
4. Sweep = as necessary to capture the entire dwell time per hopping channel
5. Detector function = peak
6. Trace = max hold

The marker-delta function was used to determine the dwell time.

10.5.Test Result

Model Number	ID-80125001-001		
Test Item	Time of Occupancy (Dwell Time)		
Test Mode	Mode 2: GFSK Link Mode		
Date of Test	03/27/2012	Test Site	TE02
DH1			
Cycle Calculate	$79\text{CH} * 0.4 = 31.6 \text{ (sec)}$		
The EUT Hopping Number per Sec	1600 times/sec		
Each Channel Dwell Times per Sec	$800/79\text{CH} = 10.13(\text{times/sec})$		
Each Channel Dwell Times (1)	0.5667	ms (sec)	
Each Channel Dwell Times on Cycle(2)	$31.6 * 10.13 = 320.108(\text{times})$		
Dwell Times on Cycle (1) * (2)	181.4052	ms (sec)	
LIMIT(msec)	< = 400		
DH3			
Cycle Calculate	$79\text{CH} * 0.4 = 31.6 \text{ (sec)}$		
The EUT Hopping Number per Sec	1600 times/sec		
Each Channel Dwell Times per Sec	$400/79\text{CH} = 5.1(\text{times/sec})$		
Each Channel Dwell Times (1)	1.8170	ms (sec)	
Each Channel Dwell Times on Cycle(2)	$31.6 * 5.1 = 161.16(\text{times})$		
Dwell Times on Cycle (1) * (2)	292.8277	ms (sec)	
LIMIT(msec)	< = 400		
DH5			
Cycle Calculate	$79\text{CH} * 0.4 = 31.6 \text{ (sec)}$		
The EUT Hopping Number per Sec	1600 times/sec		
Each Channel Dwell Times per Sec	$266.7/79\text{CH} = 3.37(\text{times/sec})$		
Each Channel Dwell Times (1)	3.1000	ms (sec)	
Each Channel Dwell Times on Cycle(2)	$31.6 * 3.37 = 106.492(\text{times})$		
Dwell Times on Cycle (1) * (2)	330.1252	ms (sec)	
LIMIT(msec)	< = 400		

10.6. Test Graphs

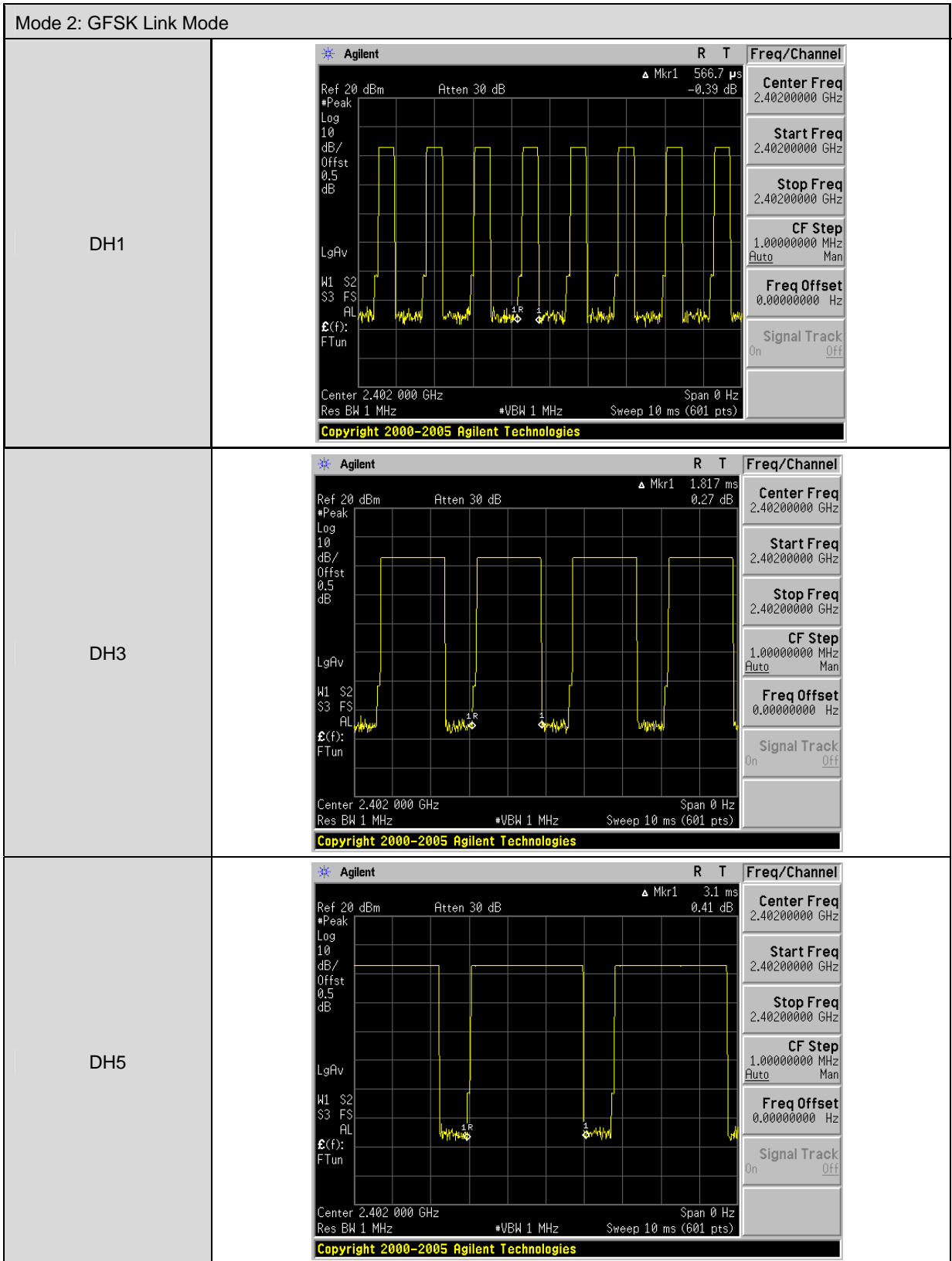

11 Out of Band Conducted Emissions Measurement

11.1.Limit

In any 100 kHz bandwidth outside the frequency band in which the spread spectrum or digitally modulated intentional radiator is operating, the radio frequency power that is produced by the intentional radiator shall be at least 20 dB below that in the 100 kHz bandwidth within the band that contains the highest level of the desired power

11.2.Test Setup

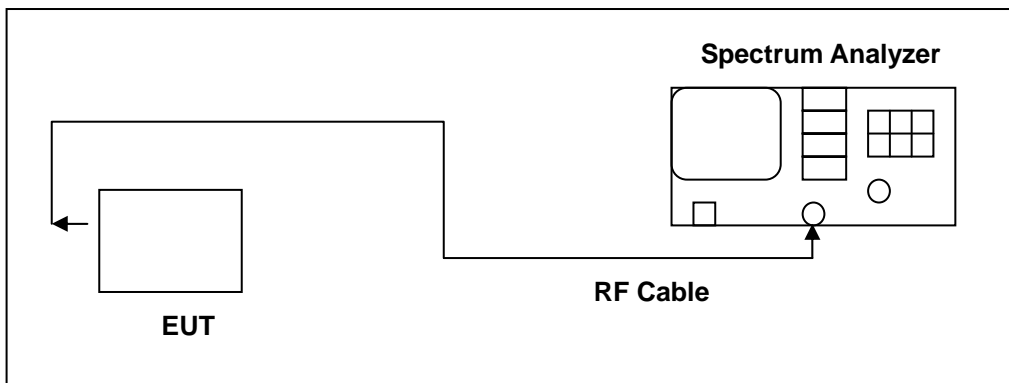

11.3.Test Instruments

Equipment	Manufacturer	Model Number	Serial Number	Cal. Date	Remark
Spectrum Analyzer	Agilent	E4445A	MY45300744	12/20/2011	(1)
Spectrum Analyzer	Agilent	E4408B	MY45107753	07/07/2011	(1)
Test Site	ATL	TE02	TE02	N.C.R.	-----

Remark: (1) Calibration period 1 year. (2) Calibration period 2 years.

NOTE: N.C.R. = No Calibration Request.

11.4.Test Procedure

In any 100 kHz bandwidth outside the EUT pass band, the RF power produced by the modulation products of the spreading sequence, the information sequence, and the carrier frequency shall be at least 20 dB below that of the maximum in-band 100 kHz emission, antenna output of the EUT was coupled directly to spectrum analyzer; if an external attenuator and/or cable was used, these losses are compensated for with the analyzer OFFSET function.

All other types of emissions from the EUT shall meet the general limits for radiated frequencies outside the pass band. The test was performed at 3 channels (Channel 0, 39, 78)

11.5. Test Graphs

Mode 2: GFSK Link Mode											
2402	<p>Agilent R T Ref 20 dBm Atten 30 dB Mkr1 2.40 GHz Peak 1.753 dBm Log 10 dB/ Offst 0.5 dB DI -18.2 dBm</p> <p>Start 30 MHz Stop 26.5 GHz #Res BW 100 kHz #VBW 100 kHz Sweep 3.41 s (401 pts)</p> <table border="1"> <thead> <tr> <th>Marker</th> <th>Trace</th> <th>Type</th> <th>X Axis</th> <th>Amplitude</th> </tr> </thead> <tbody> <tr> <td>1</td> <td>(1)</td> <td>Freq</td> <td>2.40 GHz</td> <td>1.753 dBm</td> </tr> </tbody> </table> <p>Freq/Channel Center Freq 13.2650000 GHz Start Freq 30.0000000 MHz Stop Freq 26.5000000 GHz CF Step 2.64700000 GHz Auto Man Freq Offset 0.0000000 Hz Signal Track On Off</p>	Marker	Trace	Type	X Axis	Amplitude	1	(1)	Freq	2.40 GHz	1.753 dBm
Marker	Trace	Type	X Axis	Amplitude							
1	(1)	Freq	2.40 GHz	1.753 dBm							
2441	<p>Agilent R T Ref 20 dBm Atten 30 dB Mkr1 2.44 GHz Peak 0.612 dBm Log 10 dB/ Offst 0.5 dB DI -19.4 dBm</p> <p>Start 30 MHz Stop 26.5 GHz #Res BW 100 kHz #VBW 100 kHz Sweep 3.41 s (401 pts)</p> <table border="1"> <thead> <tr> <th>Marker</th> <th>Trace</th> <th>Type</th> <th>X Axis</th> <th>Amplitude</th> </tr> </thead> <tbody> <tr> <td>1</td> <td>(1)</td> <td>Freq</td> <td>2.44 GHz</td> <td>0.612 dBm</td> </tr> </tbody> </table> <p>Freq/Channel Center Freq 13.2650000 GHz Start Freq 30.0000000 MHz Stop Freq 26.5000000 GHz CF Step 2.64700000 GHz Auto Man Freq Offset 0.0000000 Hz Signal Track On Off</p>	Marker	Trace	Type	X Axis	Amplitude	1	(1)	Freq	2.44 GHz	0.612 dBm
Marker	Trace	Type	X Axis	Amplitude							
1	(1)	Freq	2.44 GHz	0.612 dBm							
2480	<p>Agilent R T Ref 20 dBm Atten 30 dB Mkr1 2.48 GHz Peak -0.755 dBm Log 10 dB/ Offst 0.5 dB DI -20.8 dBm</p> <p>Start 30 MHz Stop 26.5 GHz #Res BW 100 kHz #VBW 100 kHz Sweep 3.41 s (401 pts)</p> <table border="1"> <thead> <tr> <th>Marker</th> <th>Trace</th> <th>Type</th> <th>X Axis</th> <th>Amplitude</th> </tr> </thead> <tbody> <tr> <td>1</td> <td>(1)</td> <td>Freq</td> <td>2.48 GHz</td> <td>-0.755 dBm</td> </tr> </tbody> </table> <p>Freq/Channel Center Freq 13.2650000 GHz Start Freq 30.0000000 MHz Stop Freq 26.5000000 GHz CF Step 2.64700000 GHz Auto Man Freq Offset 0.0000000 Hz Signal Track On Off</p>	Marker	Trace	Type	X Axis	Amplitude	1	(1)	Freq	2.48 GHz	-0.755 dBm
Marker	Trace	Type	X Axis	Amplitude							
1	(1)	Freq	2.48 GHz	-0.755 dBm							

12 Band Edges Measurement

12.1.Limit

In any 100 kHz bandwidth outside the frequency band in which the spread spectrum or digitally modulated intentional radiator is operating, the radio frequency power that is produced by the intentional radiator shall be at least 20 dB below that in the 100 kHz bandwidth within the band that contains the highest level of the desired power

12.2.Test Setup

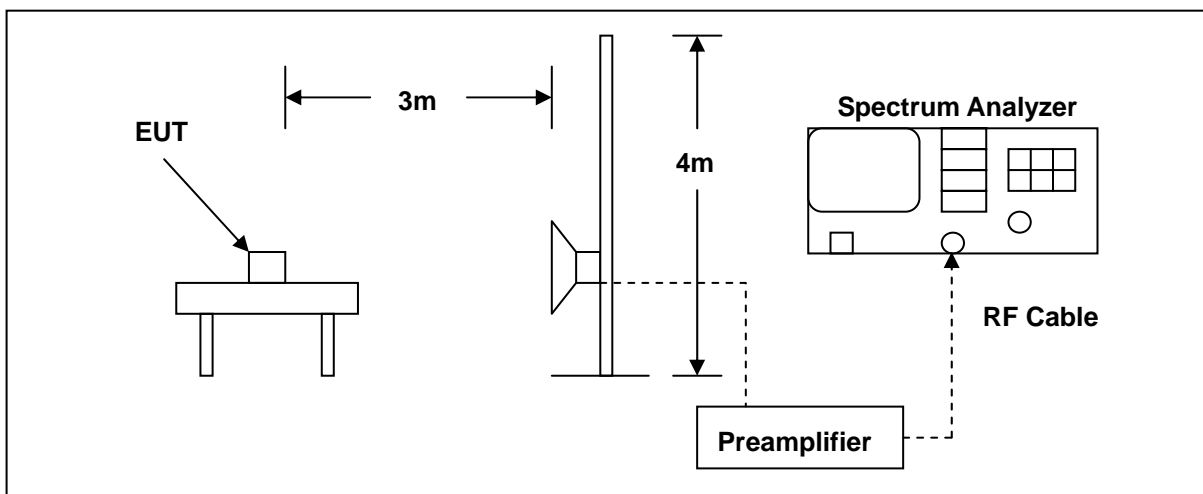

12.3.Test Instruments

Equipment	Manufacturer	Model Number	Serial Number	Cal. Date	Remark
Spectrum Analyzer	Agilent	E4408B	MY45107753	07/07/2011	(1)
Pre Amplifier	Agilent	8449B	3008A02237	02/22/2012	(1)
Horn Antenna	SCHWARZBECK MESS-ELEKTRONIK	9120D	9120D-550	06/29/2011	(1)
Test Site	ATL	TE01	888001	12/20/2011	(1)

Remark: (1) Calibration period 1 year. (2) Calibration period 2 years.

NOTE: N.C.R. = No Calibration Request.

12.4. Test Procedure

The emissions on the harmonics frequencies, the limits, and the margin of compliance are presented. These tests were made when the transmitter was in full radiated power. The additional test was performed to show compliance with the requirement at the band-edge frequency 2483.5 MHz and up to 2500 MHz and at 2390.0 MHz.

The transmitter was configured with the worst case antenna and setup to transmit at the highest channel. Then the field strength was measured at 2483.5 MHz.

The transmitter was then configured with the worst case antenna and setup to transmit at the lowest channel. Then the field strength was measured at 2390.0 MHz. These tests were performed at 4 different bit rates.

For measurements the resolution bandwidth is set to 1 MHz, and then the video bandwidth is set to 1 MHz for peak measurements and 10 Hz for average measurements.

12.5.Test Result

Standard:	FCC Part 15C	Test Distance:	3m
Test item:	Radiated Emission	Power:	AC 120V/60Hz
Model Number:	ID-80125001-001	Temp.(°C)/Hum.(%RH):	26(°C)/60%RH
Mode:	Mode 2	Date:	03/28/2012
Frequency:	2402 MHz	Test By:	Fly Lu
Ant.Polar.:	Horizontal		

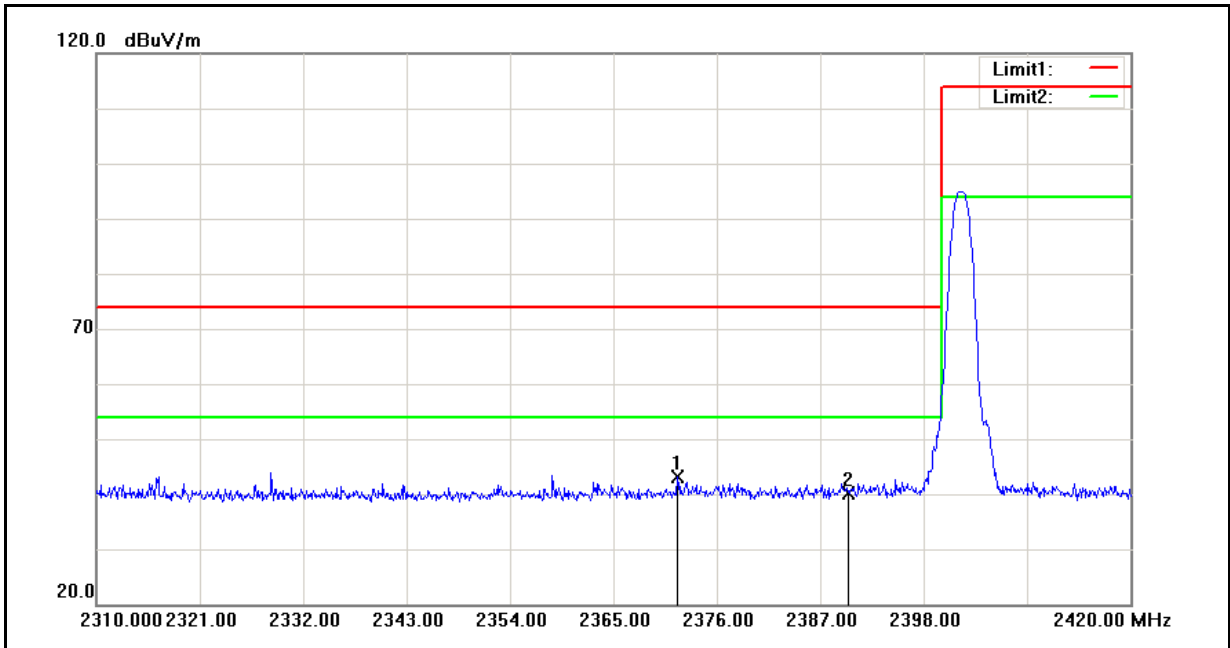

No.	Frequency (MHz)	Reading (dBuV)	Correct Factor(dB/m)	Result (dBuV/m)	Limit (dBuV/m)	Margin (dB)	Remark
1	2371.820	43.15	-0.13	43.02	74.00	-30.98	peak
2	2390.000	40.23	-0.06	40.17	74.00	-33.83	peak

Standard:	FCC Part 15C	Test Distance:	3m
Test item:	Radiated Emission	Power:	AC 120V/60Hz
Model Number:	ID-80125001-001	Temp.(°C)/Hum.(%RH):	26(°C)/60%RH
Mode:	Mode 2	Date:	03/28/2012
Frequency:	2402 MHz	Test By:	Fly Lu
Ant.Polar.:	Vertical		

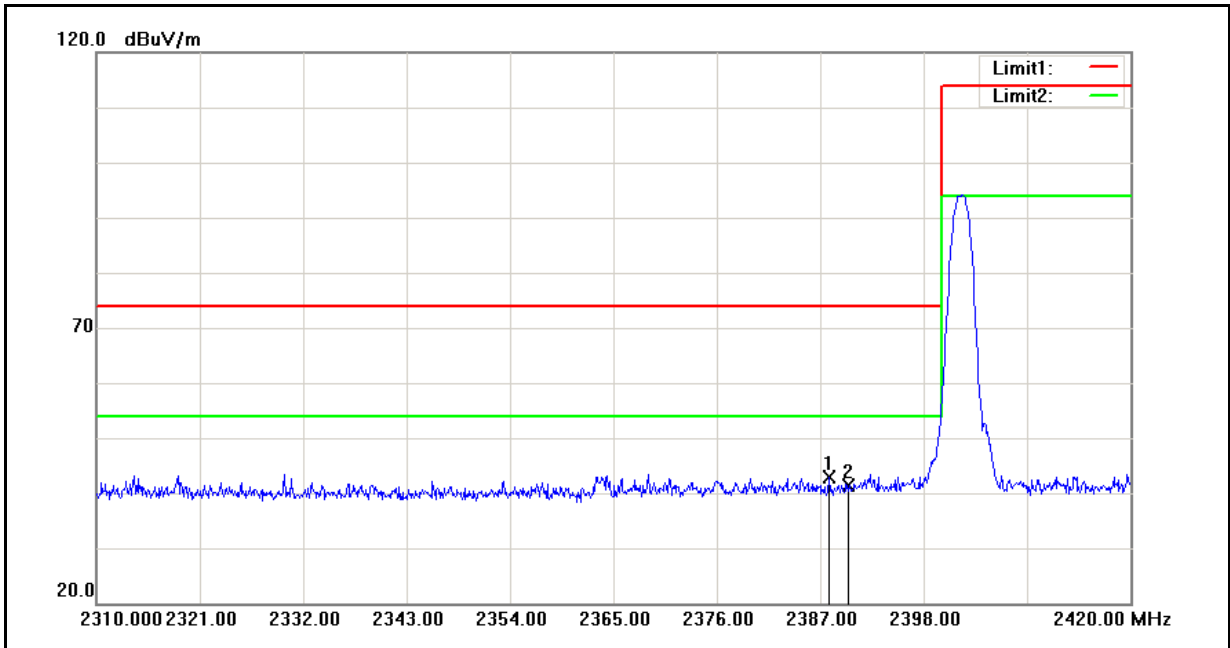

No.	Frequency (MHz)	Reading (dBuV)	Correct Factor(dB/m)	Result (dBuV/m)	Limit (dBuV/m)	Margin (dB)	Remark
1	2387.990	43.04	-0.07	42.97	74.00	-31.03	peak
2	2390.000	41.39	-0.06	41.33	74.00	-32.67	peak

Standard:	FCC Part 15C	Test Distance:	3m
Test item:	Radiated Emission	Power:	AC 120V/60Hz
Model Number:	ID-80125001-001	Temp.(°C)/Hum.(%RH):	26(°C)/60%RH
Mode:	Mode 2	Date:	03/28/2012
Frequency:	2480 MHz	Test By:	Fly Lu
Ant.Polar.:	Horizontal		

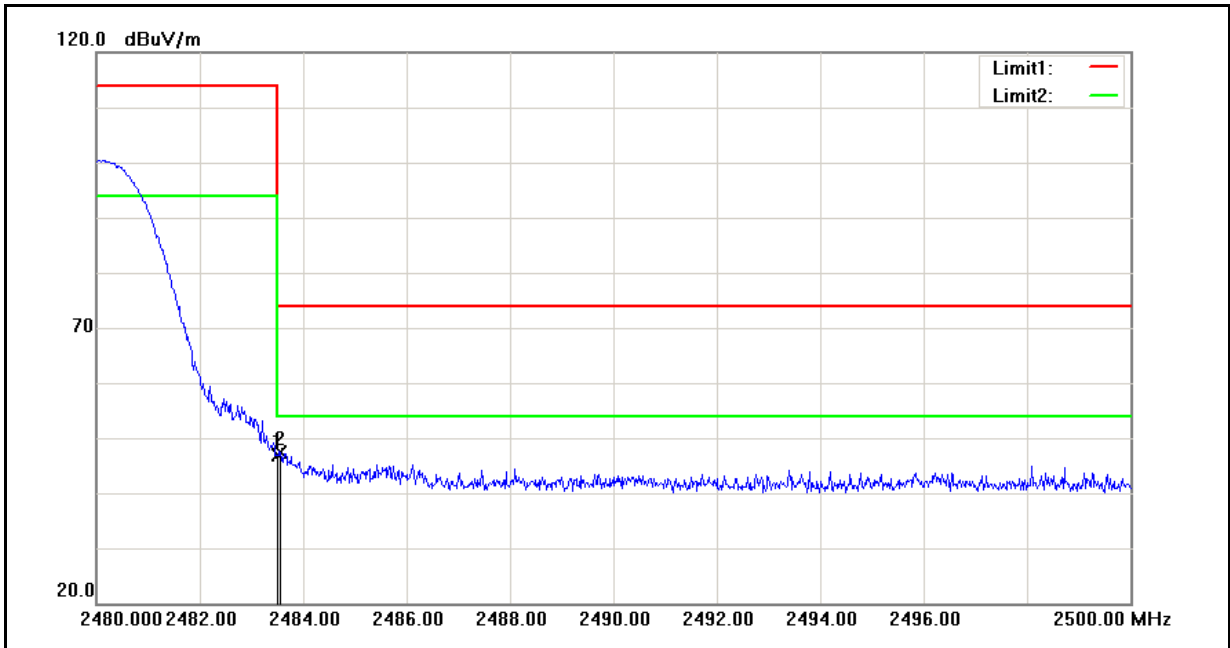

No.	Frequency (MHz)	Reading (dBuV)	Correct Factor(dB/m)	Result (dBuV/m)	Limit (dBuV/m)	Margin (dB)	Remark
1	2483.500	46.62	0.35	46.97	74.00	-27.03	peak
2	2483.560	46.92	0.35	47.27	74.00	-26.73	peak

Standard:	FCC Part 15C	Test Distance:	3m
Test item:	Radiated Emission	Power:	AC 120V/60Hz
Model Number:	ID-80125001-001	Temp.(°C)/Hum.(%RH):	26(°C)/60%RH
Mode:	Mode 2	Date:	03/28/2012
Frequency:	2480 MHz	Test By:	Fly Lu
Ant.Polar.:	Vertical		

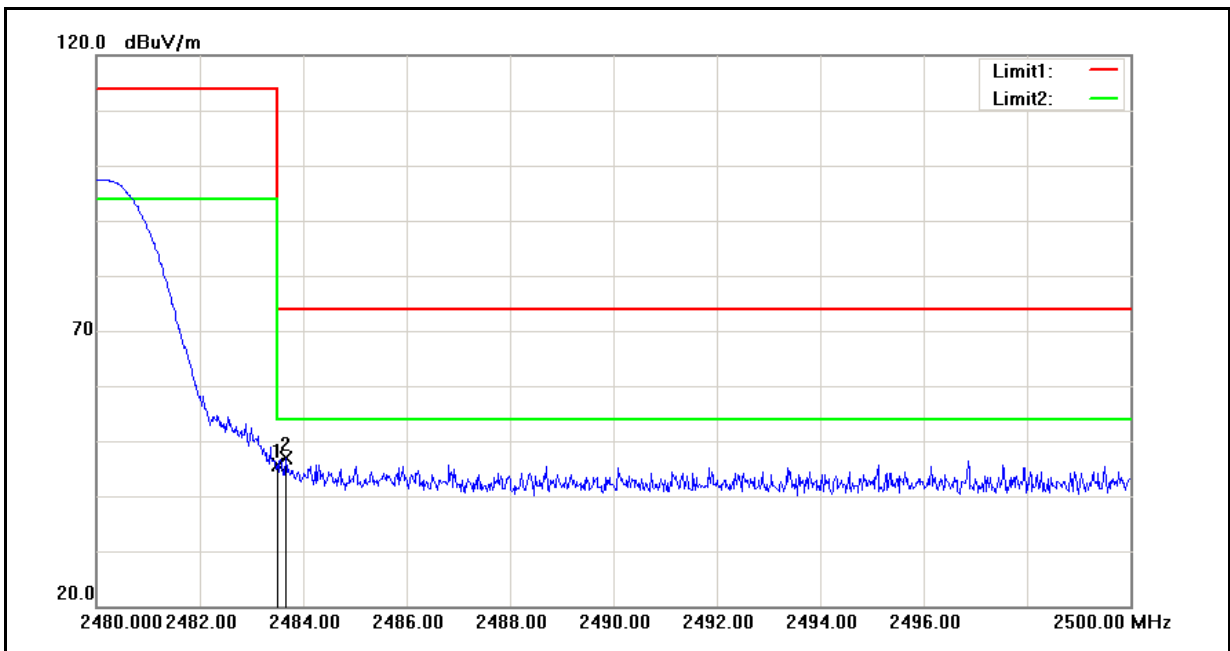

No.	Frequency (MHz)	Reading (dBuV)	Correct Factor(dB/m)	Result (dBuV/m)	Limit (dBuV/m)	Margin (dB)	Remark
1	2483.500	45.30	0.35	45.65	74.00	-28.35	peak
2	2483.660	46.45	0.35	46.80	74.00	-27.20	peak

Standard:	FCC Part 15C	Test Distance:	3m
Test item:	Radiated Emission	Power:	AC 120V/60Hz
Model Number:	ID-80125001-001	Temp.(°C)/Hum.(%RH):	26(°C)/60%RH
Mode:	Hopping	Date:	03/28/2012
Ant.Polar.:	Horizontal	Test By:	Fly Lu

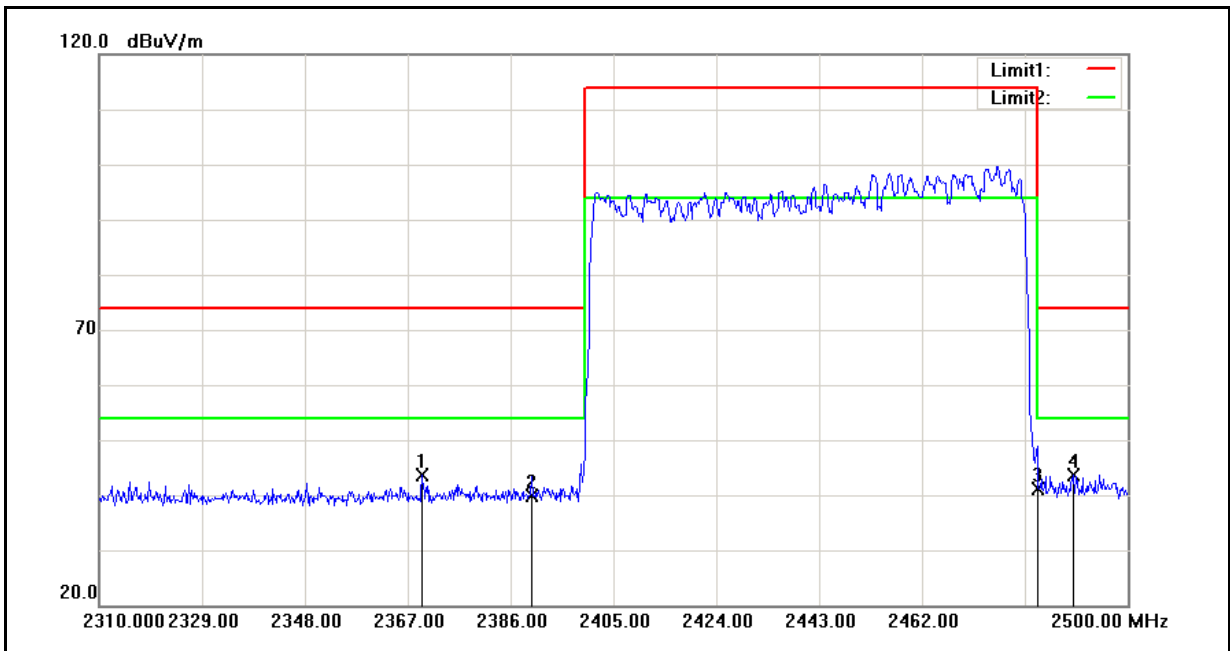

No.	Frequency (MHz)	Reading (dBuV)	Correct Factor(dB/m)	Result (dBuV/m)	Limit (dBuV/m)	Margin (dB)	Remark
1	2369.660	43.68	-0.14	43.54	74.00	-30.46	peak
2	2390.000	40.04	-0.06	39.98	74.00	-34.02	peak
3	2483.500	40.68	0.35	41.03	74.00	-32.97	peak
4	2489.930	43.25	0.38	43.63	74.00	-30.37	peak

Standard:	FCC Part 15C	Test Distance:	3m
Test item:	Radiated Emission	Power:	AC 120V/60Hz
Model Number:	ID-80125001-001	Temp.(°C)/Hum.(%RH):	26(°C)/60%RH
Mode:	Hopping	Date:	03/28/2012
Ant.Polar.:	Vertical	Test By:	Fly Lu

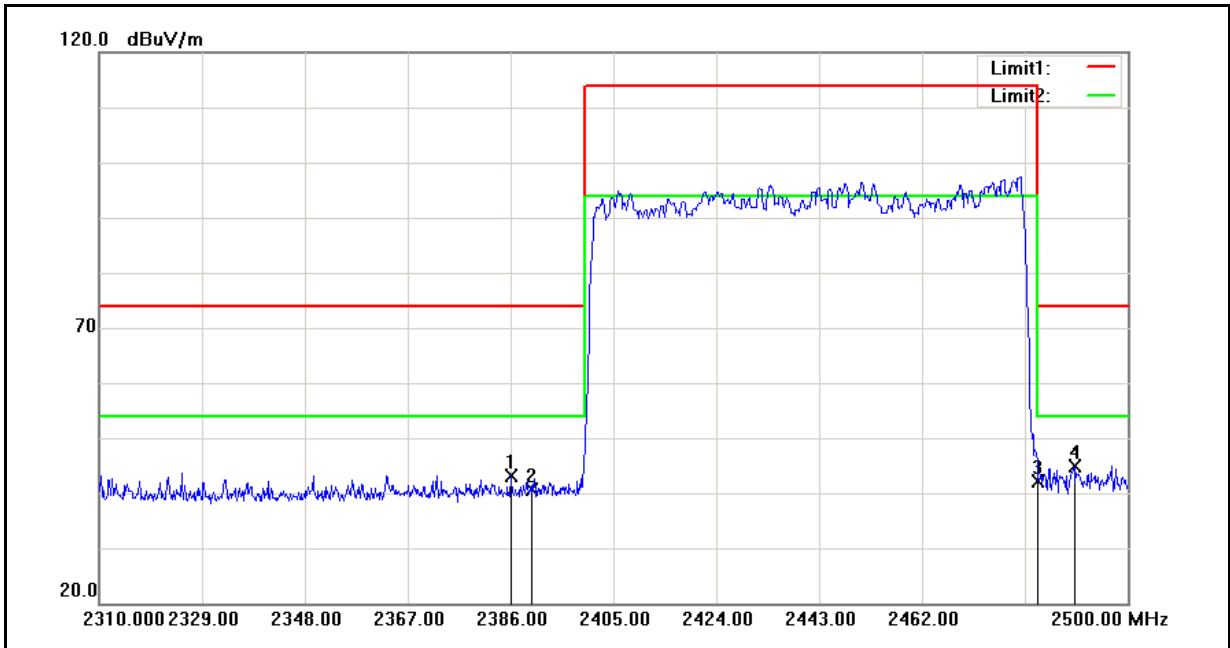

No.	Frequency (MHz)	Reading (dBuV)	Correct Factor(dB/m)	Result (dBuV/m)	Limit (dBuV/m)	Margin (dB)	Remark
1	2386.000	43.13	-0.08	43.05	74.00	-30.95	peak
2	2390.000	40.65	-0.06	40.59	74.00	-33.41	peak
3	2483.500	41.73	0.35	42.08	74.00	-31.92	peak
4	2490.120	44.53	0.38	44.91	74.00	-29.09	peak

13 99 % Occupied Bandwidth Measurement

13.1.Limit

N/A

13.2.Test Setup

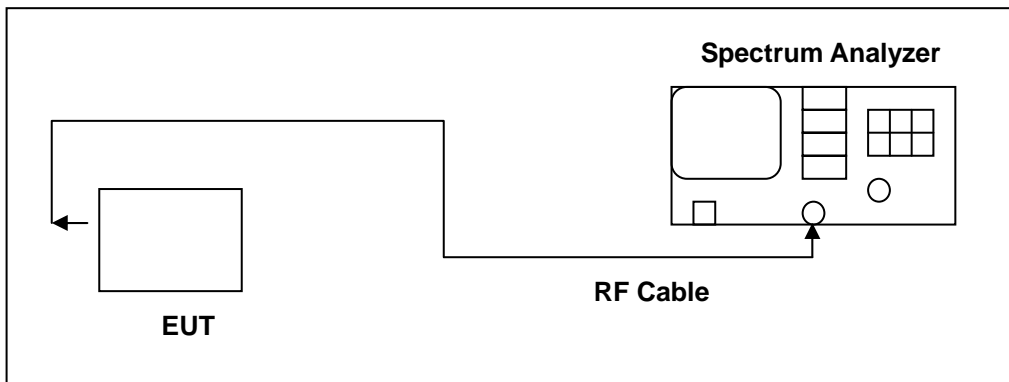

13.3.Test Instruments

Equipment	Manufacturer	Model Number	Serial Number	Cal. Date	Remark
Spectrum Analyzer	Agilent	E4445A	MY45300744	12/20/2011	(1)
Test Site	ATL	TE02	TE02	N.C.R.	-----

Remark: (1) Calibration period 1 year. (2) Calibration period 2 years.

NOTE: N.C.R. = No Calibration Request.

13.4.Test Procedure

The transmitter shall be operated at its maximum carrier power measured under normal test conditions. The span of the analyzer shall be set to capture all products of the modulation process, including the emission skirts. The resolution bandwidth shall be set to as close to 1% of the selected span as is possible without being below 1%. The video bandwidth shall be set to 3 times the resolution bandwidth. Video averaging is not permitted. Where practical, a sampling detector shall be used since a peak or, peak hold, may produce a wider bandwidth than actual.

The trace data points are recovered and are directly summed in linear terms. The recovered amplitude data points, beginning at the lowest frequency, are placed in a running sum until 0.5% of the total is reached and that frequency recorded. The process is repeated for the highest frequency data points. This frequency is recorded.

13.5. Test Result

Model Number	ID-80125001-001		
Test Item	99 % Occupied Bandwidth		
Test Mode	Mode 2: GFSK Link Mode		
Date of Test	06/22/2010	Test Site	TE02
	Frequency (MHz)	Measurement (MHz)	Limit (MHz)
	2402	0.8829302	-----
	2441	0.8860664	-----
	2480	0.8847544	-----

13.6. Test Graphs

Mode 2: GFSK Link Mode	
2402	<p>Agilent R T Freq/Channel</p> <p>Ch Freq 2.402 GHz Trig Free</p> <p>Center Freq 2.40200000 GHz</p> <p>Start Freq 2.40050000 GHz</p> <p>Stop Freq 2.40350000 GHz</p> <p>CF Step 300.000000 kHz Auto Man</p> <p>Freq Offset 0.00000000 Hz</p> <p>Signal Track On Off</p> <p>Ref 20 dBm Atten 30 dB</p> <p>#Samp 10</p> <p>Log dB/ Offst 0.5 dB</p> <p>Center 2.402 000 GHz Span 3 MHz</p> <p>#Res BW 30 kHz #VBW 100 kHz Sweep 10.04 ms (601 pts)</p> <p>Occupied Bandwidth 882.9302 kHz</p> <p>Occ BW % Pwr 99.00 %</p> <p>x dB -26.00 dB</p> <p>Transmit Freq Error -8.541 kHz</p> <p>x dB Bandwidth 1.136 MHz*</p> <p>Copyright 2000-2005 Agilent Technologies</p>
2441	<p>Agilent R T Freq/Channel</p> <p>Ch Freq 2.441 GHz Trig Free</p> <p>Center Freq 2.44100000 GHz</p> <p>Start Freq 2.43950000 GHz</p> <p>Stop Freq 2.44250000 GHz</p> <p>CF Step 300.000000 kHz Auto Man</p> <p>Freq Offset 0.00000000 Hz</p> <p>Signal Track On Off</p> <p>Ref 20 dBm Atten 30 dB</p> <p>#Samp 10</p> <p>Log dB/ Offst 0.5 dB</p> <p>Center 2.441 000 GHz Span 3 MHz</p> <p>#Res BW 30 kHz #VBW 100 kHz Sweep 10.04 ms (601 pts)</p> <p>Occupied Bandwidth 886.0664 kHz</p> <p>Occ BW % Pwr 99.00 %</p> <p>x dB -26.00 dB</p> <p>Transmit Freq Error -10.651 kHz</p> <p>x dB Bandwidth 1.131 MHz*</p> <p>Copyright 2000-2005 Agilent Technologies</p>
2480	<p>Agilent R T Freq/Channel</p> <p>Ch Freq 2.48 GHz Trig Free</p> <p>Center Freq 2.48000000 GHz</p> <p>Start Freq 2.47850000 GHz</p> <p>Stop Freq 2.48150000 GHz</p> <p>CF Step 300.000000 kHz Auto Man</p> <p>Freq Offset 0.00000000 Hz</p> <p>Signal Track On Off</p> <p>Ref 20 dBm Atten 30 dB</p> <p>#Samp 10</p> <p>Log dB/ Offst 0.5 dB</p> <p>Center 2.480 000 GHz Span 3 MHz</p> <p>#Res BW 30 kHz #VBW 100 kHz Sweep 10.04 ms (601 pts)</p> <p>Occupied Bandwidth 884.7544 kHz</p> <p>Occ BW % Pwr 99.00 %</p> <p>x dB -26.00 dB</p> <p>Transmit Freq Error -9.225 kHz</p> <p>x dB Bandwidth 1.132 MHz*</p> <p>Copyright 2000-2005 Agilent Technologies</p>

14 Antenna Measurement

14.1.Limit

For intentional device, according to 15.203, an intentional radiator shall be designed to ensure that no antenna other than that furnished by the responsible party shall be used with the device.

And According to 15.247 (b), if transmitting antennas of directional gain greater than 6 dBi are used, the power shall be reduced by the amount in dB that the directional gain of the antenna exceeds 6dBi.

14.2.Antenna Connector Construction

The antenna used in this product is **Multilayer Chip Antenna**. And the maximum Gain of this antenna is only **2.5 dBi**.