



FCC TEST REPORT

according to

FCC Part 15, Subpart C (15.249) / ANSI C63.4: 2003

Applicant	: IDEalltech Technology Co.,Ltd.
Address	: 8F No 411-1Sec 4 Ren-ai Rd, Da-an District, Taipei, 106, Taiwan
Equipment	: 2.4G Mobile Keyboard
Model No.	: RF240-50K
FCC ID	: WQFIDL0050

Laboratory Accreditation



- The test result refers exclusively to the test presented test model / sample.,
- Without written approval of **CerpPASS Technology Corp.** the test report shall not be reproduced except in full.



Contents

1.	Report of Measurements and Examinations.....	4
1.1.	List of Measurements and Examinations.....	4
2.	Test Configuration of Equipment under Test.....	5
2.1.	Feature of Equipment under Test.....	5
2.2.	Carrier Frequency of Channels.....	6
2.3.	Test Mode and Test Software.....	6
2.4.	Description of Test System.....	7
2.5.	Connection Diagram of Test System.....	7
2.6.	History of this test report.....	8
3.	General Information of Test.....	9
4.	Test of Conducted Emission.....	10
4.1.	Test Limit.....	10
4.2.	Test Procedures.....	10
4.3.	Typical Test Setup.....	11
4.4.	Test Result and Data.....	11
5.	Test of Radiated Emission.....	12
5.1.	Test Limit.....	12
5.2.	Test Procedures.....	12
5.3.	Typical Test Setup Layout of Radiated Emission.....	13
5.4.	Measurement equipment.....	13
5.5.	Test Result and Data.....	14
5.6.	Test Photographs.....	34
Appendix A.	Photographs of EUT.....	A1 ~ A5



CERTIFICATE OF COMPLIANCE

according to

FCC Part 15, Subpart C (15.249) / ANSI C63.4: 2003

Applicant	:	IDEalltech Technology Co.,Ltd.
Address	:	8F No 411-1Sec 4 Ren-ai Rd, Da-an District, Taipei, 106, Taiwan
Equipment	:	2.4G Mobile Keyboard
Model No.	:	RF240-50K
FCC ID	:	WQFIDL0050

I **HEREBY** CERTIFY THAT :

The measurements shown in this test report were made in accordance with the procedures given in **ANSI C63.4**. The equipment was **passed** the test performed according to **FCC Part 15, Subpart C (15.249) / ANSI C63.4: 2003**.

The test was carried out on Nov. 08, 2010 at **CerpPASS Technology Corp.**

Signature

Anson Chou
EMC/RF B.U. Vice General Manager



1. Report of Measurements and Examinations

1.1. List of Measurements and Examinations

FCC Rule	Test Type	Result	Remark
15.207	Conducted Emission	Pass	6Vdc from batteries
15.209 15.249	Radiated Emission	Pass	Minimum Passing margin is -9.08 at 936.30 MHz

Note: the information of measurement uncertainty is available upon the customer's request.



2. Test Configuration of Equipment under Test

2.1. Feature of Equipment under Test

Feature:

- Handy compact devise for living room entertainment.
- Watch PC program on TV screen with easy control from Mobile Keyborad.
- Combo of keyboard & chat with friends on your TV screen.
- Mouse Left, Right & sensor cursor control in compact keybord
- Control Volume or forward music/ movie clip very easily

Spec:

- Optical sensor
- Resolution: 400 dpi
- Power consumption: 14mA
- Button: 56-key keyboard/ Optical Touch Pad/ direction key button
- Power-on when push out Nano USB receiver.
- Power-off when push in Nano USB receiver.
- Dimension: 110mm x 60mm x 18mm
- Weight: 76g
- Frequency: 2.4GHz wireless
- Connection range: upto 10M
- Battery: 2pcs Alkaline AAA battery
- Battery life: 3~4 month
- Low battery indication: blue LED light flashing
- Push-in Nano USB receiver storage.



2.2. Carrier Frequency of Channels

Channel	Frequency(MHz)	Channel	Frequency(MHz)	Channel	Frequency(MHz)
01	2403	26	2427	51	2453
02	2404	27	2428	52	2454
03	2405	28	2429	53	2455
04	2406	29	2430	54	2456
05	2407	30	2431	55	2457
06	2408	31	2432	56	2458
07	2409	32	2433	57	2459
08	2410	33	2435	58	2460
09	2411	34	2436	59	2461
10	2412	35	2437	60	2462
11	2413	36	2438	61	2463
12	2414	37	2439	62	2464
13	2415	38	2440	63	2465
14	2416	39	2441	64	2466
15	2417	40	2442	65	2467
16	2418	41	2443	66	2468
17	2419	42	2444	67	2469
18	2420	43	2445	68	2470
19	2421	44	2446	69	2471
20	2421	45	2447	70	2472
21	2422	46	2448	71	2473
22	2423	47	2449	72	2474
23	2424	48	2450	73	2475
24	2425	49	2451	74	2476
25	2426	50	2452	75	2477

2.3. Test Mode and Test Software

- a. During testing, the interface cables and equipment positions were varied according to ANSI C63.4.
- b. The complete test system included PC, Monitor, Keyboard, Modem, Mouse, Printer, USB Receiver and EUT for EMI test.
- c. The EUT was executed to keep transmitting and receiving data via Wireless.
- d. The following test mode were performed for conduction and radiation test:
 - TX Mode (Transmitting signal by clicking button)
 - RX Mode (Receiving signal)
 - CH01: 2403MHz, CH03: 2440MHz, CH5: 2477MHz



2.4. Description of Test System

Device	Manufacturer	Model No.	Description
PC	DELL	D02M	Power Cable, Unshielding 1.8m
Monitor	PHILIPS	202P73	Power Cable, Unshielding 1.8 m Data Cable, VGA Shielding 1.35 m
Keyboard	Logitech	Y-SU61	Data Cable, PS2 Shielding, 1.85m
Mouse	Logitech	OF-2854	Data Cable, PS2 Shielding, 1.85m
Modem	ACEXX	DM-1414	Power Cable, Adapter Unshielding 1.8 m Data Cable, RS232 Shielding 1.35 m
Printer	hp	Desk Jet400	Power Cable, Adapter Unshielding 1.8 m Data Cable, Print Shielding 1.6 m
USB Receiver	idealltech	N/A	N/A

2.5. Connection Diagram of Test System

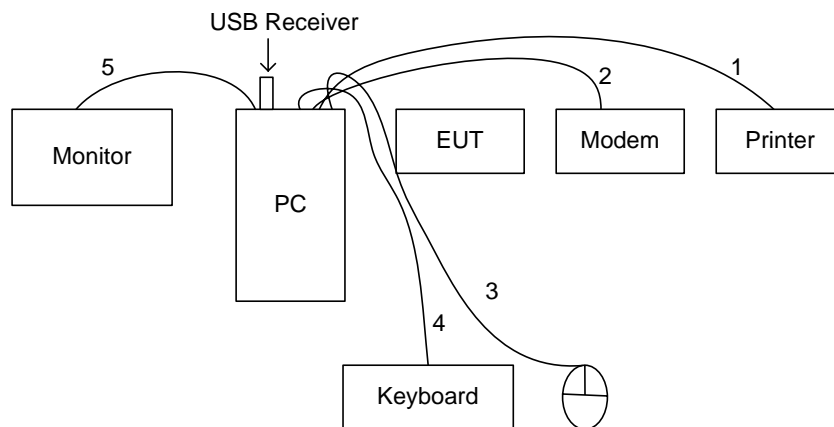

1. The Print cable is connected from PC to Printer
 2. The RS232 cable is connected from PC to Modem.
 3. The PS/2 cable is connected from PC to the Mouse
 4. The PS/2 cable is connected from PC to Keyboard.
 5. The VGA cable is connected from PC to Monitor.
- *The EUT is connecting to the USB receiver with wireless..



3. General Information of Test

Test Site :	CerpPASS Technology Corp. 2F-11, No. 3, Yuan Qu St. (Nankang Software Park), Taipei, Taiwan 115, R.O.C.
Test Site Location (OATS1-SD):	No. 68-1, Shibachong Si, Shihding Township, Taipei County, Taiwan, R.O.C.
FCC Registration Number :	TW1061, TW1056, 390316, 488071
IC Registration Number :	4934B-1, 4934D-1
VCCI Registration Number :	T-543 for Telecommunication Test C-3328 for Conducted emission test R-3428 for Radiated emission test G-97 for Radiated emission test above 1GHz.
Test Voltage:	DC 3V
Test in Compliance with:	FCC Part 15, Subpart C (15.249) / ANSI C63.4: 2003
Frequency Range Investigated:	Conducted Emission Test: from 150kHz to 30 MHz Radiated Emission Test: from 30 MHz to 25000 MHz
Modulation Type:	GFSK
Test Distance:	The test distance of radiated emission above 1GHz from antenna to EUT is 3 M.



4. Test of Conducted Emission

4.1. Test Limit

Conducted Emissions were measured from 150 kHz to 30 MHz with a bandwidth of 9 KHz on the 120 VAC power and return leads of the EUT according to the methods defined in ANSI C63.4-2003 Section 3.1. The EUT was placed on a nonmetallic stand in a shielded room 0.8 meters above the ground plane as shown in section 2.2. The interface cables and equipment positioning were varied within limits of reasonable applications to determine the position produced maximum conducted emissions.

Frequency (MHz)	Quasi Peak (dB μ V)	Average (dB μ V)
0.15 – 0.5	66-56*	56-46*
0.5 – 5.0	56	46
5.0 – 30.0	60	50

*Decreases with the logarithm of the frequency.

4.2. Test Procedures

- The EUT was placed 0.4 meter from the conducting wall of the shielding room was kept at least 80 centimeters from any other grounded conducting surface.
- Connect EUT to the power mains through a line impedance stabilization network (LISN).
- All the support units are connecting to the other LISN.
- The LISN provides 50 ohm coupling impedance for the measuring instrument.
- The FCC states that a 50 ohm, 50 micro-Henry LISN should be used.
- Both sides of AC line were checked for maximum conducted interference.
- The frequency range from 150 kHz to 30 MHz was searched.
- Set the test-receiver system to Peak Detect Function and Specified Bandwidth with Maximum Hold Mode.



4.3. Typical Test Setup

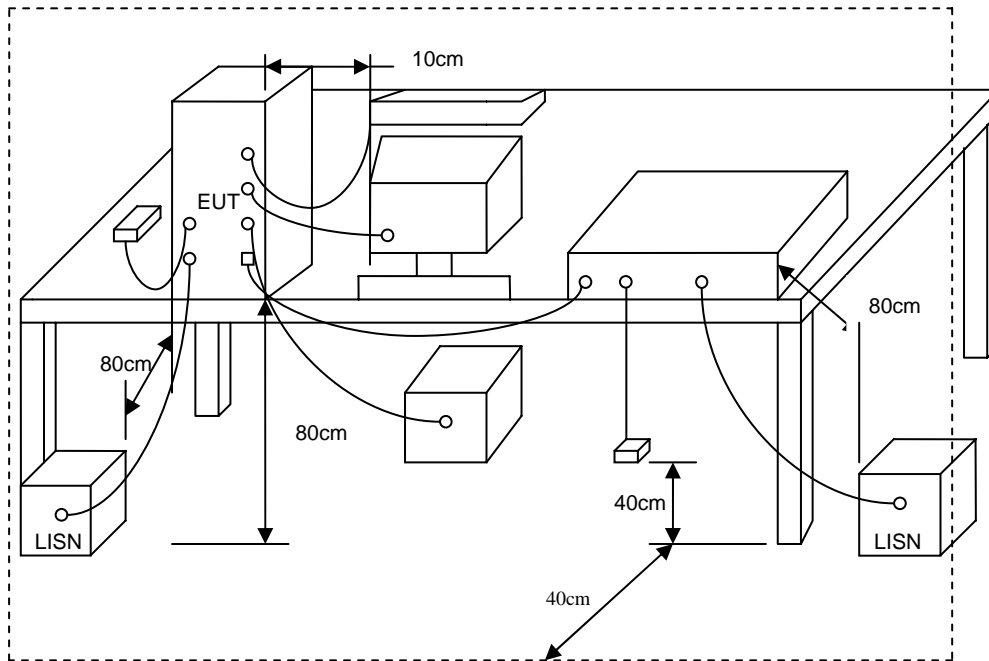

4.4. Test Result and Data

The test item is not applicable, because the EUT is powered from battery.



5. Test of Radiated Emission

5.1. Test Limit

Emissions radiated outside of the specified frequency bands, except for harmonics, shall be attenuated by at least 50 dB below the level of the fundamental or to the general radiated emission limits in § 15.209, whichever is the lesser attenuation.

Frequency (MHz)	Distance	Limit ($\mu\text{V}/\text{m}$)
0.09 ~ 0.490	300m	2400/F(kHz)
0.490 ~ 1.705	30m	24000/ F(kHz)
1.705 ~ 30	30m	30
30 ~ 88	3m	100
88 ~ 216	3m	150
216 ~ 960	3m	200
Above 960	3m	500

Fundamental Frequency:

Fundamental Frequency (MHz)	Field strength of fundamental (millivolts/meter)	Field strength of harmonics (microvolts/meter)
2400-2483.5	50	500
5725-5875	50	500
24000-24250	250	2500

5.2. Test Procedures

- The EUT was placed on a rotatable table top 0.8 meter above ground.
- The EUT was set 3 meters from the interference receiving antenna which was mounted on the top of a variable height antenna tower.
- The table was rotated 360 degrees to determine the position of the highest radiation.
- The antenna is a broadband antenna and its height is varied between one meter and four meters above ground to find the maximum value of the field strength both horizontal polarization and vertical polarization of the antenna are set to make the measurement.
- For each suspected emission the EUT was arranged to its worst case and then tune the antenna tower (from 1 M to 4 M) and turn table (from 0 degree to 360 degrees) to find the maximum reading.
- Set the test-receiver system to Peak or CISPR quasi-peak Detect Function and specified bandwidth with Maximum Hold Mode.
- If the emission level of the EUT in peak mode was 3 dB lower than the limit specified, then testing will be stopped and peak values of EUT will be reported, otherwise, the emissions which do not have 3 dB margin will be repeated one by one using the quasi-peak method and reported.
- For testing above 1GHz, the emission level of the EUT in peak mode was 20dB lower than average limit (that means the emission level in peak mode also complies with the limit in average mode), then testing will be stopped and peak values of EUT will be reported, otherwise, the emissions will be measured in average mode again and reported.
- "Cone of radiation" has been considered to be 3dB beamwidth of the measurement antenna.

NOTE:

- The resolution bandwidth and video bandwidth of test receiver/spectrum analyzer is 120kHz for Peak detection (PK) and Quasi-peak detection (QP) at frequency below 1GHz.
- The resolution bandwidth and video bandwidth of test receiver/spectrum analyzer is 1 MHz for Peak detection at frequency above 1GHz.
- The resolution bandwidth of test receiver/spectrum analyzer is 1 MHz and the video bandwidth is 10 Hz for Average detection (AV) at frequency above 1GHz.



5.3. Typical Test Setup Layout of Radiated Emission

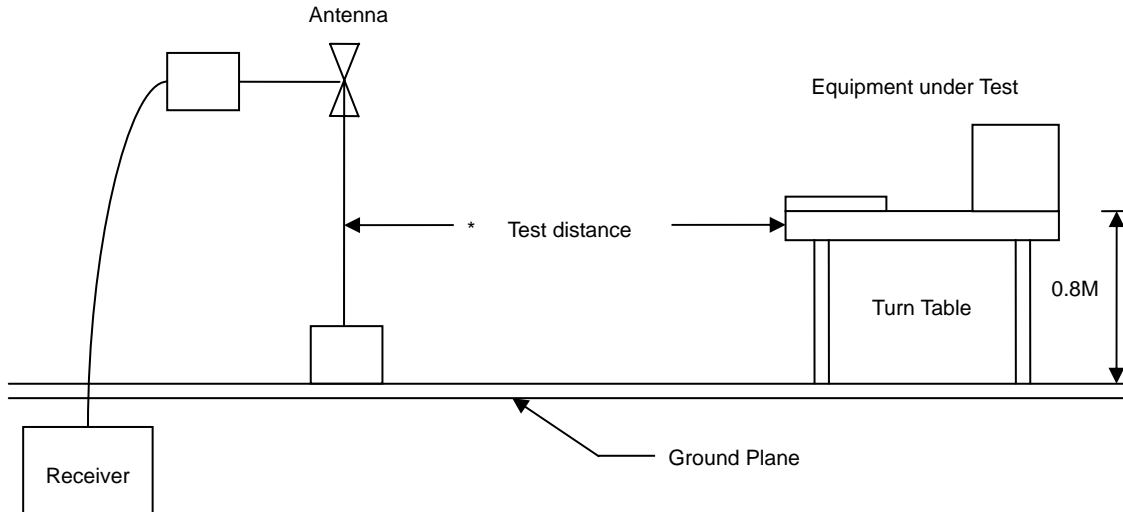

5.4. Measurement equipment

Instrument/Ancillary	Manufacturer	Model No.	Serial No.	Calibration Date	Valid Date
EMI Receiver	SCHAFFNER	SCR3501	437	2010/10/14	2011/10/13
Amplifier	Agilent	8447D	2944A10531	2010/02/05	2011/02/04
Bilog Antenna	Schaffner	CBL6112D	22242	2010/02/05	2011/02/04
Spectrum Analyzer	R&S	FSP 3	100800	2010/02/09	2011/02/08



5.5. Test Result and Data

5.5.1. Test Result of Fundamental Emission

Power	: DC 3V	Pol/Phase	: VERTICAL
Test Mode	: Transmit	Temperature	: 26 °C
Operation Channel	: 1	Humidity	: 57 %
Modulation Type	: GFSK	Atmospheric Pressure	: 1021 hPa

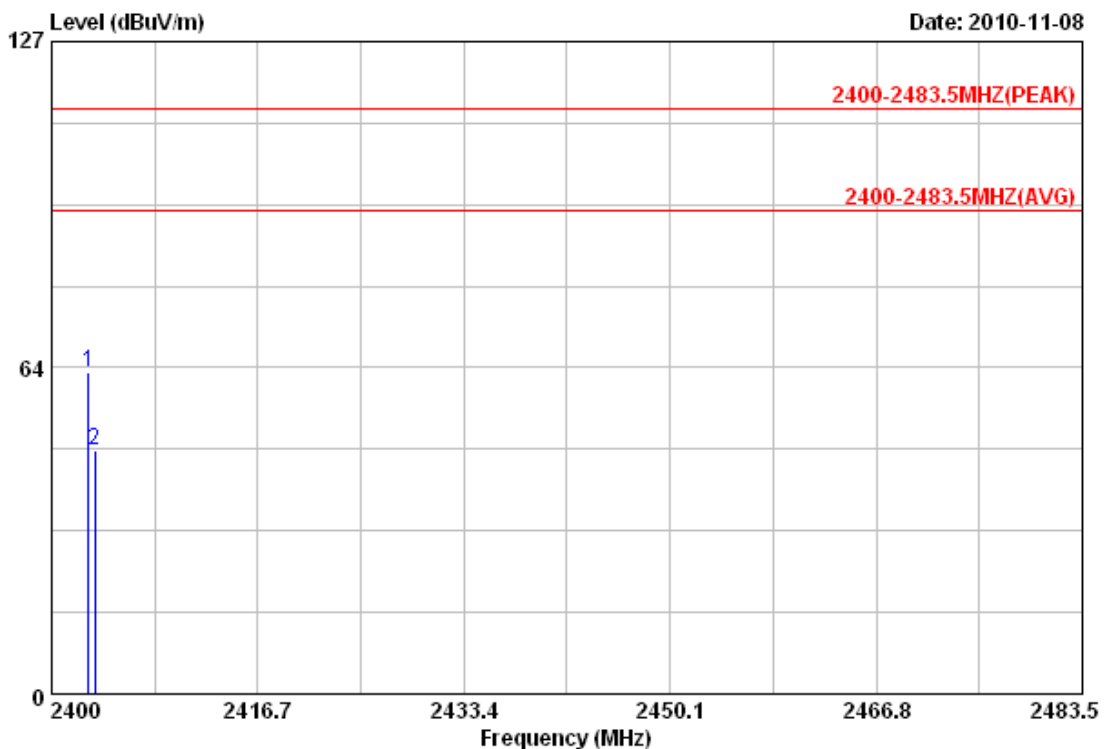

Item	Freq	Read Value	Factor	Result	Limit	Margin	Remark	Ant Pos	Tab Pos
	MHz	dBuV	dB/m	dBuV/m	dBuV/m	dB		cm	Deg
1	2403.00	55.70	6.90	62.60	114.00	-51.40	Peak	100	0
2	2403.50	40.34	6.90	47.24	94.00	-46.76	Average	100	0

Notes:

1. Result = Read Value + Factor
2. Factor = Antenna Factor + Cable Loss - Amplifier
3. The resolution bandwidth of test receiver/spectrum analyzer is 120KHz and video bandwidth is 300KHz for Peak detection and Quasi-peak detection at frequency below 1GHz.
4. The resolution bandwidth of test receiver/spectrum analyzer is 1MHz and video bandwidth is 3MHz for Peak detection at frequency above 1GHz.
5. The resolution bandwidth of test receiver/spectrum analyzer is 1MHz and video bandwidth is 10Hz for Average detection at frequency above 1GHz.
6. The other emissions is too low to be measured.



Power	: DC 3V	Pol/Phase	: HORIZONTAL
Test Mode	: Transmit	Temperature	: 26 °C
Operation Channel	: 1	Humidity	: 57 %
Modulation Type	: GFSK	Atmospheric Pressure	: 1021 hPa

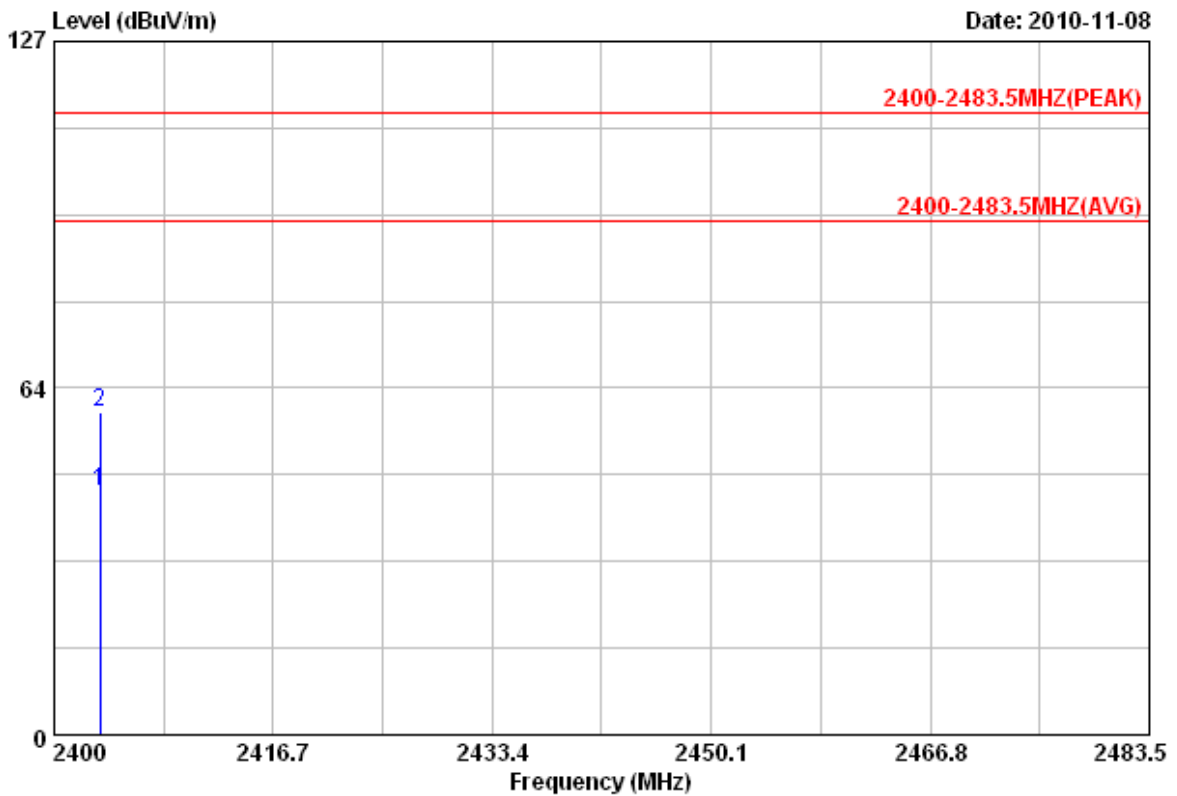

Item	Freq	Read Value	Factor	Result	Limit	Margin	Remark	Ant Pos	Tab Pos
	MHz	dBuV	dB/m	dBuV/m	dBuV/m	dB		cm	Deg
1	2403.50	37.80	6.90	44.70	94.00	-49.30	Average	100	0
2	2403.50	52.17	6.90	59.07	114.00	-54.93	Peak	100	0

Notes:

1. Result = Read Value + Factor
2. Factor = Antenna Factor + Cable Loss - Amplifier
3. The resolution bandwidth of test receiver/spectrum analyzer is 120KHz and video bandwidth is 300kHz for Peak detection and Quasi-peak detection at frequency below 1GHz.
4. The resolution bandwidth of test receiver/spectrum analyzer is 1MHz and video bandwidth is 3MHz for Peak detection at frequency above 1GHz.
5. The resolution bandwidth of test receiver/spectrum analyzer is 1MHz and video bandwidth is 10Hz for Average detection at frequency above 1GHz.
6. The other emissions is too low to be measured.



Power	: DC 3V	Pol/Phase	: VERTICAL
Test Mode	: Transmit	Temperature	: 26 °C
Operation Channel	: 38	Humidity	: 57 %
Modulation Type	: GFSK	Atmospheric Pressure	: 1021 hPa

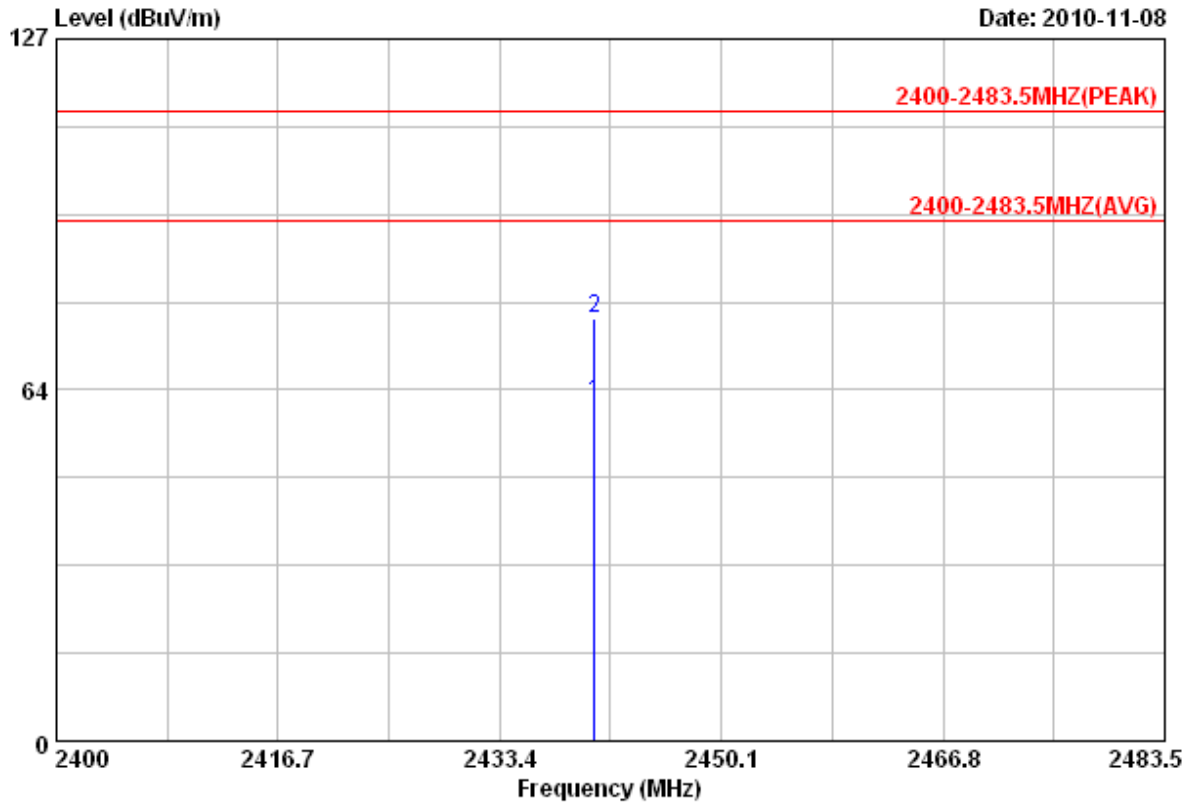

Item	Freq	Read Value	Factor	Result	Limit	Margin	Remark	Ant Pos	Tab Pos
	MHz	dBuV	dB/m	dBuV/m	dBuV/m	dB		cm	Deg
1	2440.50	54.08	7.02	61.10	94.00	-32.90	Average	100	0
2	2440.50	69.22	7.02	76.24	114.00	-37.76	Peak	100	0

Notes:

1. Result = Read Value + Factor
2. Factor = Antenna Factor + Cable Loss - Amplifier
3. The resolution bandwidth of test receiver/spectrum analyzer is 120KHz and video bandwidth is 300kHz for Peak detection and Quasi-peak detection at frequency below 1GHz.
4. The resolution bandwidth of test receiver/spectrum analyzer is 1MHz and video bandwidth is 3MHz for Peak detection at frequency above 1GHz.
5. The resolution bandwidth of test receiver/spectrum analyzer is 1MHz and video bandwidth is 10Hz for Average detection at frequency above 1GHz.
6. The other emissions is too low to be measured.



Power	: DC 3V	Pol/Phase	: HORIZONTAL
Test Mode	: Transmit	Temperature	: 26 °C
Operation Channel	: 38	Humidity	: 57 %
Modulation Type	: GFSK	Atmospheric Pressure	: 1021 hPa

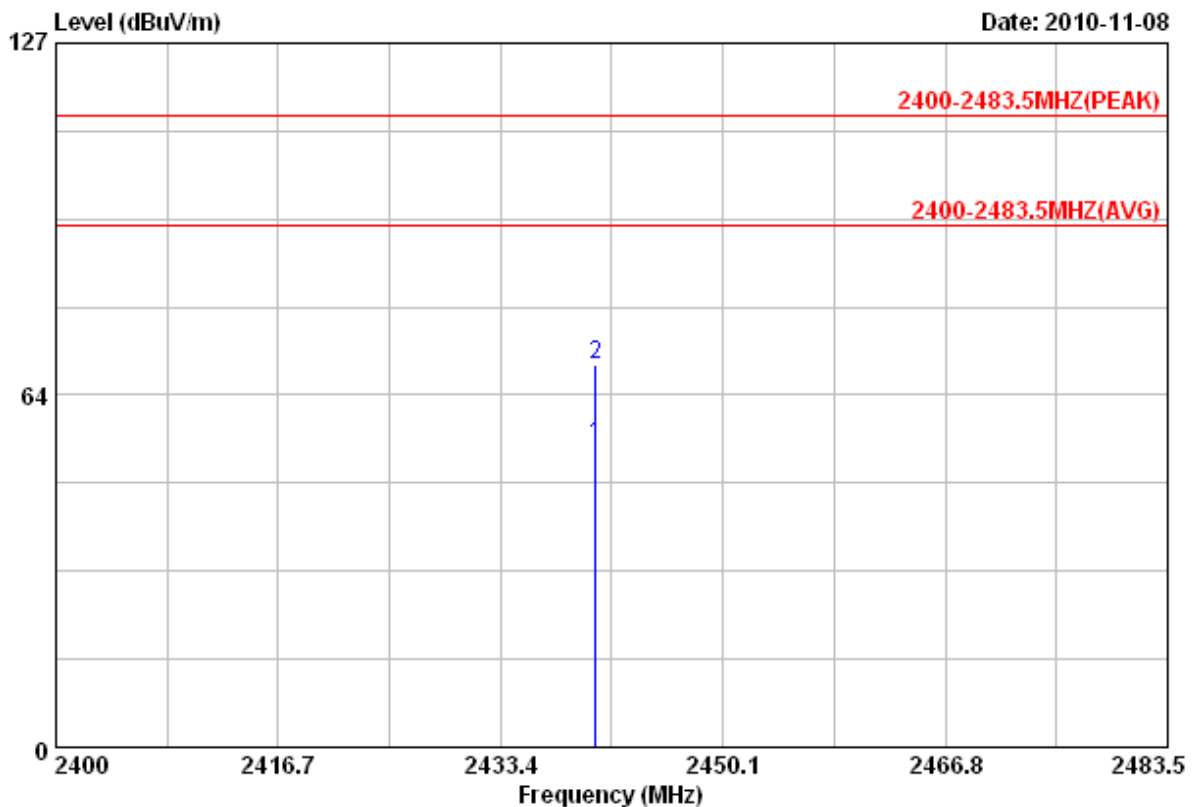

Item	Freq	Read Value	Factor	Result	Limit	Margin	Remark	Ant Pos	Tab Pos
	MHz	dBuV	dB/m	dBuV/m	dBuV/m	dB		cm	Deg
1	2440.50	47.36	7.02	54.38	94.00	-39.62	Average	100	0
2	2440.50	62.08	7.02	69.10	114.00	-44.90	Peak	100	0

Notes:

1. Result = Read Value + Factor
2. Factor = Antenna Factor + Cable Loss - Amplifier
3. The resolution bandwidth of test receiver/spectrum analyzer is 120KHz and video bandwidth is 300kHz for Peak detection and Quasi-peak detection at frequency below 1GHz.
4. The resolution bandwidth of test receiver/spectrum analyzer is 1MHz and video bandwidth is 3MHz for Peak detection at frequency above 1GHz.
5. The resolution bandwidth of test receiver/spectrum analyzer is 1MHz and video bandwidth is 10Hz for Average detection at frequency above 1GHz.
6. The other emissions is too low to be measured.



Power	: DC 3V	Pol/Phase	: VERTICAL
Test Mode	: Transmit	Temperature	: 26 °C
Operation Channel	: 75	Humidity	: 57 %
Modulation Type	: GFSK	Atmospheric Pressure	: 1021 hPa

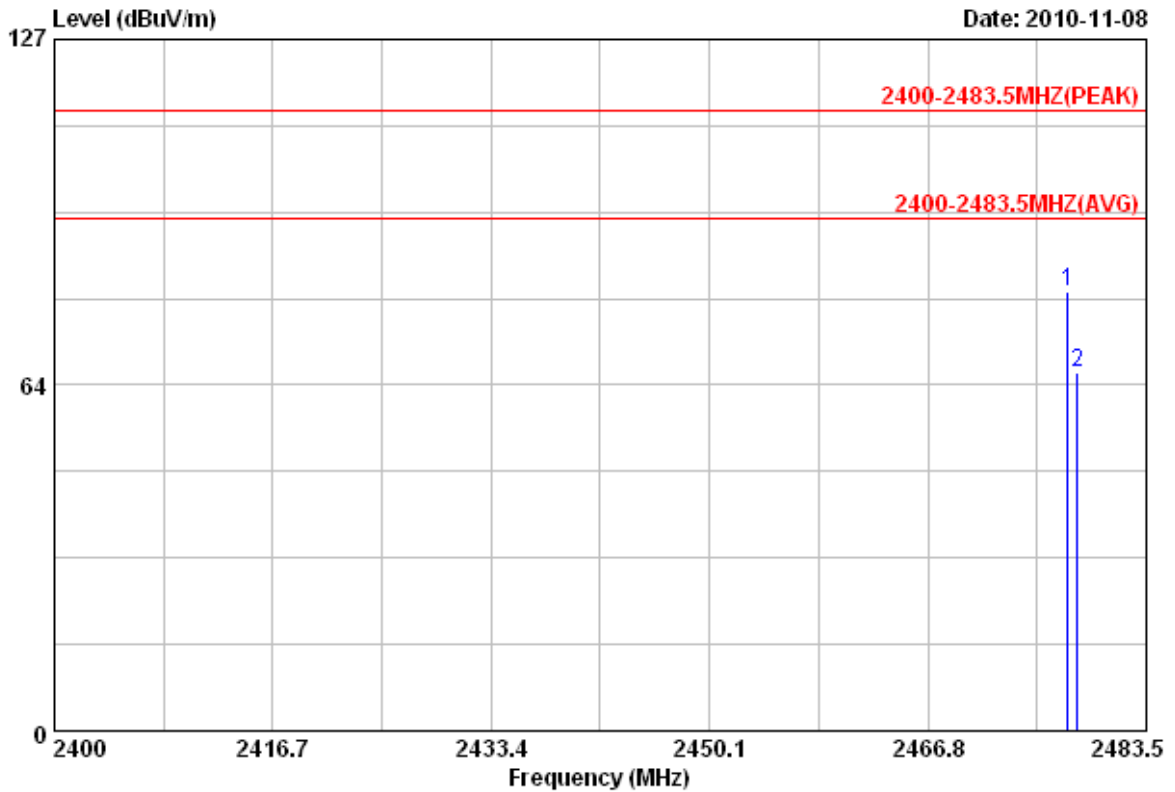

Item	Freq	Read Value	Factor	Result	Limit	Margin	Remark	Ant Pos	Tab Pos
	MHz	dBuV	dB/m	dBuV/m	dBuV/m	dB		cm	Deg
1	2477.50	73.56	7.14	80.70	114.00	-33.30	Peak	100	0
2	2478.25	58.60	7.14	65.74	94.00	-28.26	Average	100	0

Notes:

1. Result = Read Value + Factor
2. Factor = Antenna Factor + Cable Loss - Amplifier
3. The resolution bandwidth of test receiver/spectrum analyzer is 120KHz and video bandwidth is 300kHz for Peak detection and Quasi-peak detection at frequency below 1GHz.
4. The resolution bandwidth of test receiver/spectrum analyzer is 1MHz and video bandwidth is 3MHz for Peak detection at frequency above 1GHz.
5. The resolution bandwidth of test receiver/spectrum analyzer is 1MHz and video bandwidth is 10Hz for Average detection at frequency above 1GHz.
6. The other emissions is too low to be measured.



Power	: DC 3V	Pol/Phase	: HORIZONTAL
Test Mode	: Transmit	Temperature	: 26 °C
Operation Channel	: 75	Humidity	: 57 %
Modulation Type	: GFSK	Atmospheric Pressure	: 1021 hPa

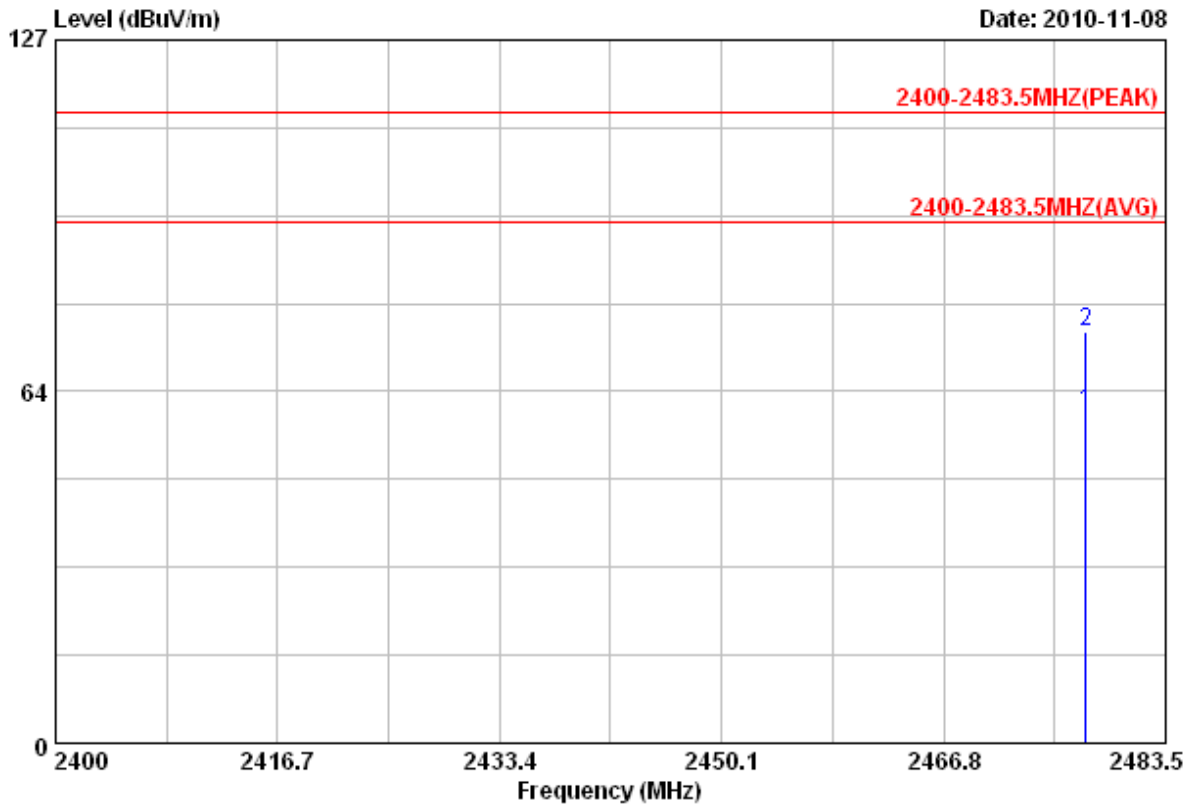

Item	Freq	Read Value	Factor	Result	Limit	Margin	Remark	Ant Pos	Tab Pos
	MHz	dBuV	dB/m	dBuV/m	dBuV/m	dB		cm	Deg
1	2477.50	52.70	7.14	59.84	94.00	-34.16	Average	100	0
2	2477.50	67.21	7.14	74.35	114.00	-39.65	Peak	100	0

Notes:

1. Result = Read Value + Factor
2. Factor = Antenna Factor + Cable Loss - Amplifier
3. The resolution bandwidth of test receiver/spectrum analyzer is 120KHz and video bandwidth is 300kHz for Peak detection and Quasi-peak detection at frequency below 1GHz.
4. The resolution bandwidth of test receiver/spectrum analyzer is 1MHz and video bandwidth is 3MHz for Peak detection at frequency above 1GHz.
5. The resolution bandwidth of test receiver/spectrum analyzer is 1MHz and video bandwidth is 10Hz for Average detection at frequency above 1GHz.
6. The other emissions is too low to be measured.



5.5.2. Test Result of Unwanted Spurious emission

Power	: DC 3V	Pol/Phase	: VERTICAL
Test Mode	: Transmit	Temperature	: 26 °C
Operation Channel	: 1	Humidity	: 57 %
Modulation Type	: GFSK	Atmospheric Pressure	: 1021 hPa

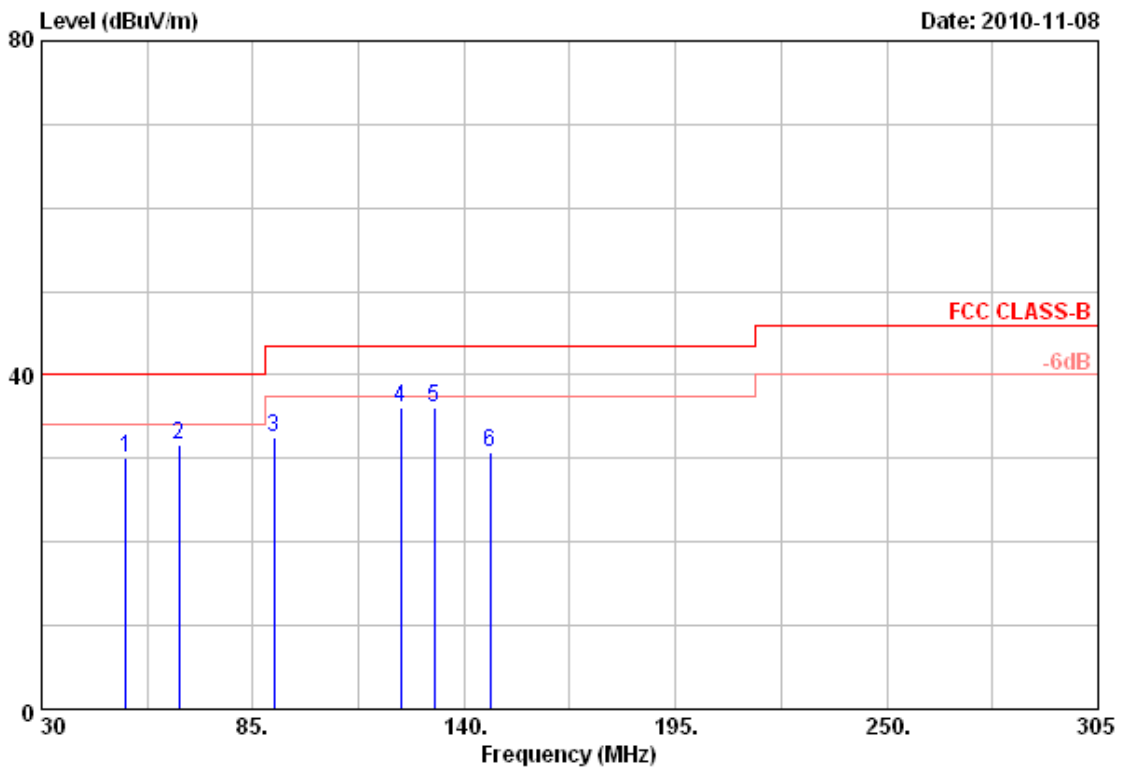

Item	Freq	Read Value	Factor	Result	Limit	Margin	Remark	Ant Pos	Tab Pos
	MHz	dBuV	dB/m	dBuV/m	dBuV/m	dB		cm	Deg
1	52.00	41.21	-11.21	30.00	40.00	-10.00	Peak	100	360
2	65.75	45.89	-14.18	31.71	40.00	-8.29	Peak	100	360
3	90.50	45.10	-12.54	32.56	43.50	-10.94	Peak	100	360
4	123.50	45.79	-9.65	36.14	43.50	-7.36	Peak	100	360
5	132.30	45.45	-9.29	36.16	43.50	-7.34	Peak	100	360
6	146.88	41.89	-11.21	30.68	43.50	-12.82	Peak	100	360

Notes:

1. Result = Read Value + Factor
2. Factor = Antenna Factor + Cable Loss - Amplifier
3. The resolution bandwidth of test receiver/spectrum analyzer is 120KHz and video bandwidth is 300kHz for Peak detection and Quasi-peak detection at frequency below 1GHz.
4. According to technical experiences, all spurious emission of GFSK mode at channel 1,38,75 are almost the same below 1GHz, so that the channel 1 was chosen as representative in final test.
5. The data is worse case.



Power	: DC 3V	Pol/Phase	: VERTICAL
Test Mode	: Transmit	Temperature	: 26 °C
Operation Channel	: 1	Humidity	: 57 %
Modulation Type	: GFSK	Atmospheric Pressure	: 1021 hPa

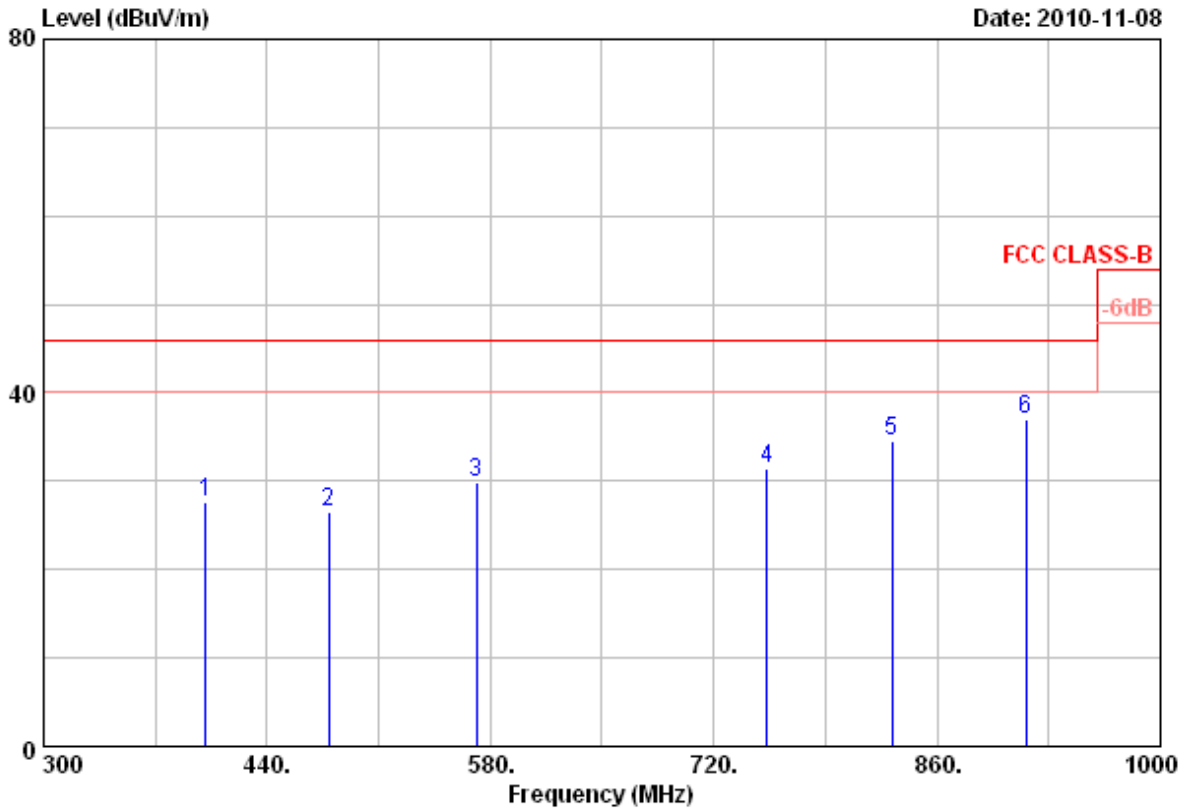

Item	Freq	Read Value	Factor	Result	Limit	Margin	Remark	Ant Pos	Tab Pos
	MHz	dBuV	dB/m	dBuV/m	dBuV/m	dB		cm	Deg
1	401.50	34.38	-6.81	27.57	46.00	-18.43	Peak	100	0
2	478.50	34.76	-8.20	26.56	46.00	-19.44	Peak	100	0
3	571.60	32.96	-3.10	29.86	46.00	-16.14	Peak	100	0
4	753.60	32.77	-1.34	31.43	46.00	-14.57	Peak	100	0
5	832.00	33.84	0.64	34.48	46.00	-11.52	Peak	100	0
6	916.00	32.91	3.99	36.90	46.00	-9.10	Peak	100	0

Notes:

1. Result = Read Value + Factor
2. Factor = Antenna Factor + Cable Loss - Amplifier
3. The resolution bandwidth of test receiver/spectrum analyzer is 120KHz and video bandwidth is 300kHz for Peak detection and Quasi-peak detection at frequency below 1GHz.
4. According to technical experiences, all spurious emission of GFSK mode at channel 1,38,75 are almost the same below 1GHz, so that the channel 1 was chosen as representative in final test.
5. The data is worse case.



Power	: DC 3V	Pol/Phase	: HORIZONTAL
Test Mode	: Transmit	Temperature	: 26 °C
Operation Channel	: 1	Humidity	: 57 %
Modulation Type	: GFSK	Atmospheric Pressure	: 1021 hPa

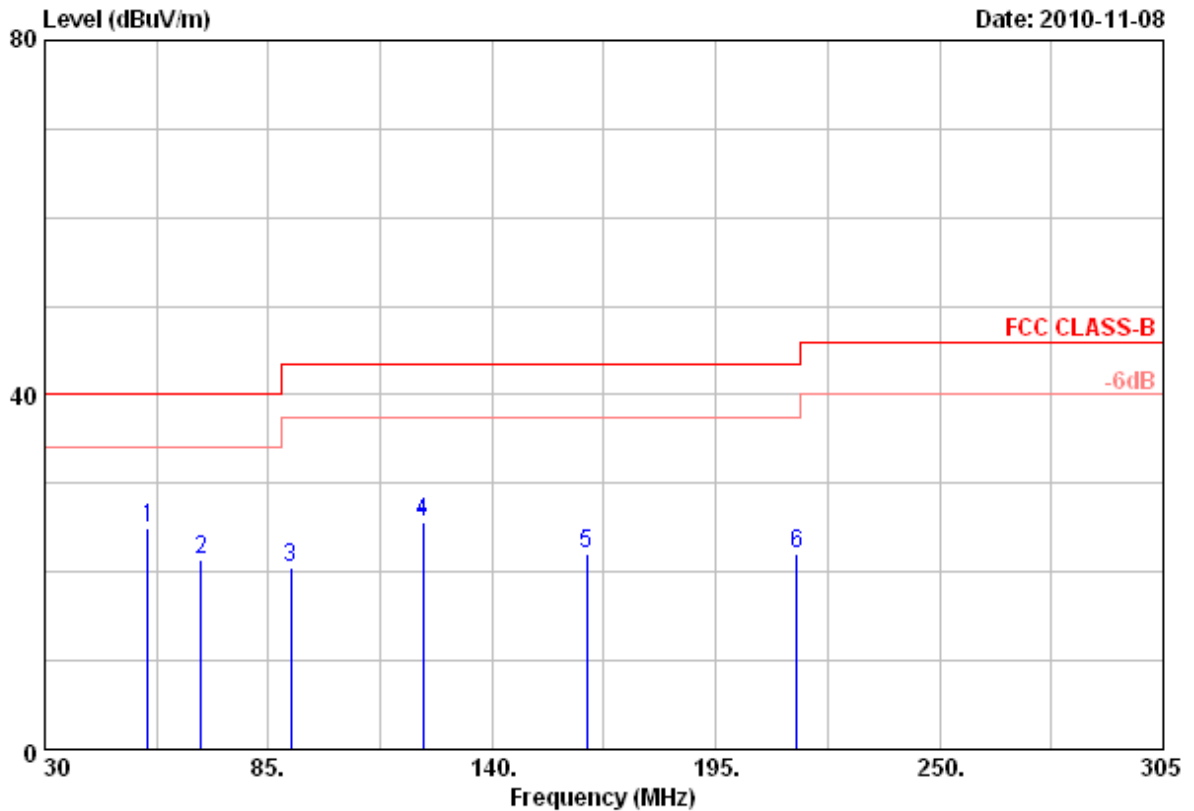

Item	Freq	Read Value	Factor	Result	Limit	Margin	Remark	Ant Pos	Tab Pos
	MHz	dBuV	dB/m	dBuV/m	dBuV/m	dB		cm	Deg
1	55.30	41.75	-16.82	24.93	40.00	-15.07	Peak	100	360
2	68.50	42.62	-21.23	21.39	40.00	-18.61	Peak	100	360
3	90.50	40.23	-19.79	20.44	43.50	-23.06	Peak	100	360
4	122.95	42.44	-16.85	25.59	43.50	-17.91	Peak	100	360
5	163.38	38.75	-16.70	22.05	43.50	-21.45	Peak	100	360
6	214.80	38.59	-16.59	22.00	43.50	-21.50	Peak	100	360

Notes:

1. Result = Read Value + Factor
2. Factor = Antenna Factor + Cable Loss - Amplifier
3. The resolution bandwidth of test receiver/spectrum analyzer is 120KHz and video bandwidth is 300kHz for Peak detection and Quasi-peak detection at frequency below 1GHz.
4. According to technical experiences, all spurious emission of GFSK mode at channel 1,38,75 are almost the same below 1GHz, so that the channel 1 was chosen as representative in final test.
5. The data is worse case.



Power	: DC 3V	Pol/Phase	: HORIZONTAL
Test Mode	: Transmit	Temperature	: 26 °C
Operation Channel	: 1	Humidity	: 57 %
Modulation Type	: GFSK	Atmospheric Pressure	: 1021 hPa

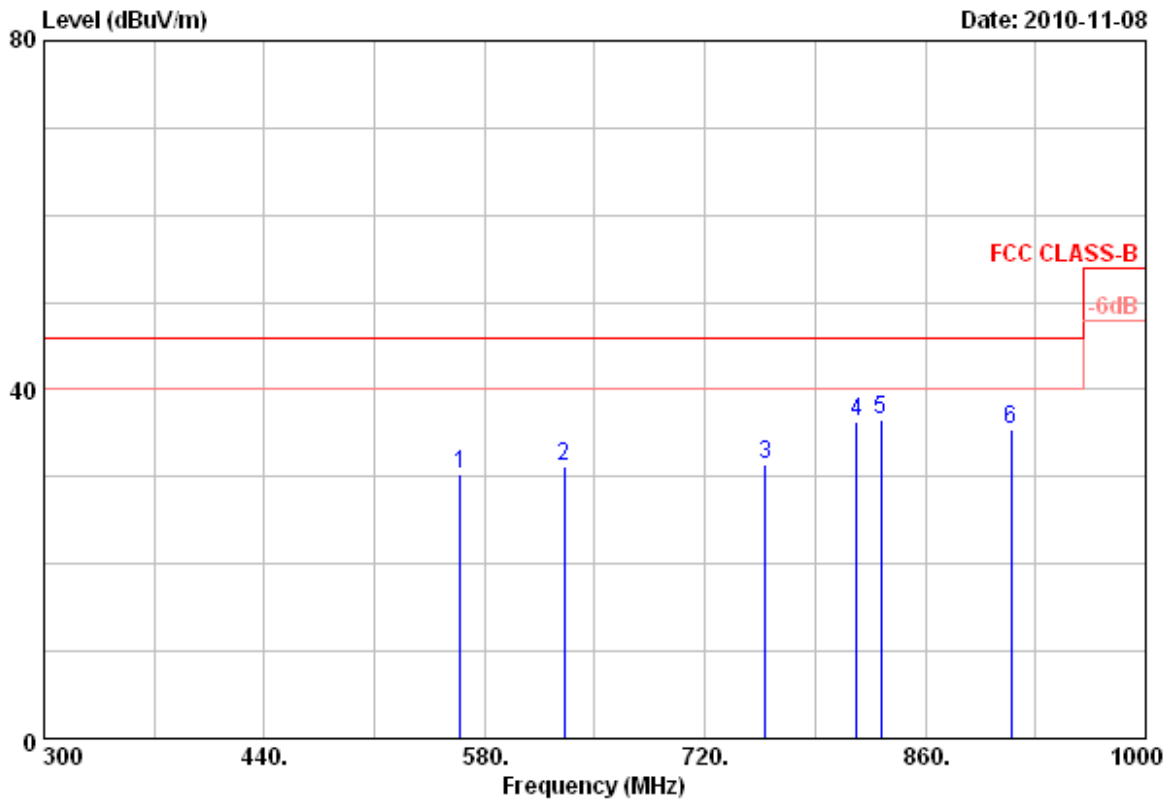

Item	Freq	Read Value	Factor	Result	Limit	Margin	Remark	Ant Pos	Tab Pos
	MHz	dBuV	dB/m	dBuV/m	dBuV/m	dB		cm	Deg
1	564.60	32.03	-1.64	30.39	46.00	-15.61	Peak	100	0
2	630.40	32.30	-1.19	31.11	46.00	-14.89	Peak	100	0
3	758.50	32.57	-1.10	31.47	46.00	-14.53	Peak	100	0
4	816.60	35.89	0.47	36.36	46.00	-9.64	Peak	100	0
5	832.00	34.86	1.76	36.62	46.00	-9.38	Peak	100	0
6	914.60	33.03	2.30	35.33	46.00	-10.67	Peak	100	0

Notes:

1. Result = Read Value + Factor
2. Factor = Antenna Factor + Cable Loss - Amplifier
3. The resolution bandwidth of test receiver/spectrum analyzer is 120KHz and video bandwidth is 300kHz for Peak detection and Quasi-peak detection at frequency below 1GHz.
4. According to technical experiences, all spurious emission of GFSK mode at channel 1,38,75 are almost the same below 1GHz, so that the channel 1 was chosen as representative in final test.
5. The data is worse case.



Power	: DC 3V	Pol/Phase	: VERTICAL
Test Mode	: Transmit	Temperature	: 26 °C
Operation Channel	: 1	Humidity	: 57 %
Modulation Type	: GFSK	Atmospheric Pressure	: 1021 hPa

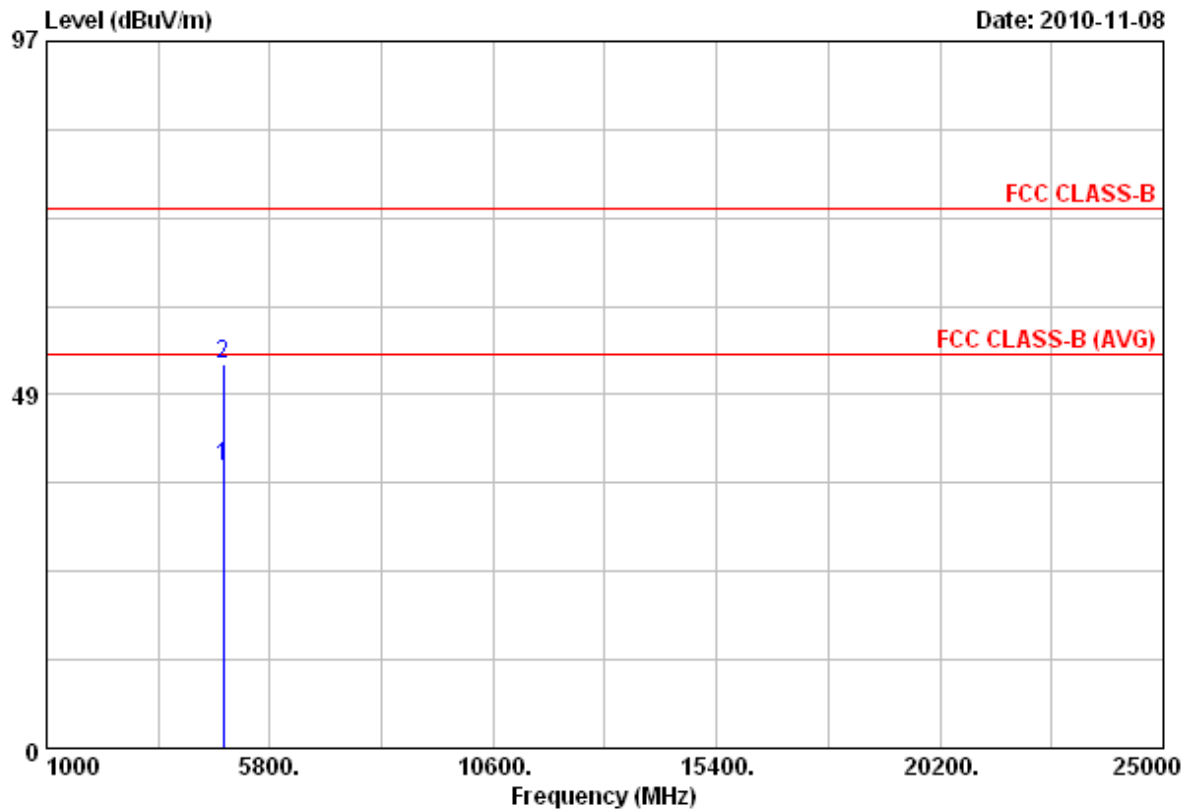

Item	Freq	Read Value	Factor	Result	Limit	Margin	Remark	Ant Pos	Tab Pos
	MHz	dBuV	dB/m	dBuV/m	dBuV/m	dB		cm	Deg
1	4806.75	26.26	12.35	38.61	54.00	-15.39	Average	100	360
2	4807.29	40.40	12.35	52.75	74.00	-21.25	Peak	100	360

Notes:

1. Result = Read Value + Factor
2. Factor = Antenna Factor + Cable Loss - Amplifier
3. The resolution bandwidth of test receiver/spectrum analyzer is 120KHz and video bandwidth is 300kHz for Peak detection and Quasi-peak detection at frequency below 1GHz.
4. The resolution bandwidth of test receiver/spectrum analyzer is 1MHz and video bandwidth is 3MHz for Peak detection at frequency above 1GHz.
5. The resolution bandwidth of test receiver/spectrum analyzer is 1MHz and video bandwidth is 10Hz for Average detection at frequency above 1GHz.
6. The other emissions is too low to be measured.



Power	: DC 3V	Pol/Phase	: VERTICAL
Test Mode	: Transmit	Temperature	: 26 °C
Operation Channel	: 1	Humidity	: 57 %
Modulation Type	: GFSK	Atmospheric Pressure	: 1021 hPa

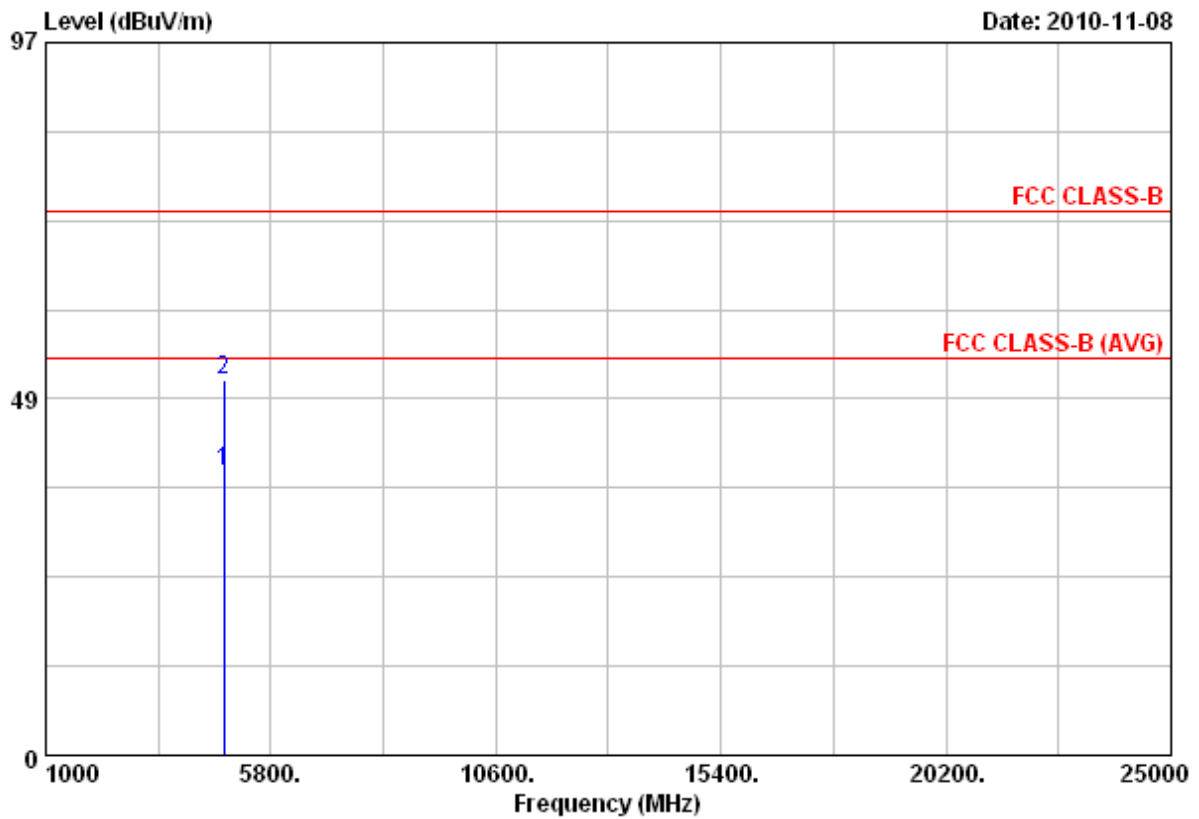

Item	Freq	Read Value	Factor	Result	Limit	Margin	Remark	Ant Pos	Tab Pos
	MHz	dBuV	dB/m	dBuV/m	dBuV/m	dB		cm	Deg
1	4806.00	26.33	12.35	38.68	54.00	-15.32	Average	100	0
2	4807.75	38.73	12.36	51.09	74.00	-22.91	Peak	100	0

Notes:

1. Result = Read Value + Factor
2. Factor = Antenna Factor + Cable Loss - Amplifier
3. The resolution bandwidth of test receiver/spectrum analyzer is 120KHz and video bandwidth is 300kHz for Peak detection and Quasi-peak detection at frequency below 1GHz.
4. The resolution bandwidth of test receiver/spectrum analyzer is 1MHz and video bandwidth is 3MHz for Peak detection at frequency above 1GHz.
5. The resolution bandwidth of test receiver/spectrum analyzer is 1MHz and video bandwidth is 10Hz for Average detection at frequency above 1GHz.
6. The other emissions is too low to be measured.



Power	: DC 3V	Pol/Phase	: VERTICAL
Test Mode	: Transmit	Temperature	: 26 °C
Operation Channel	: 38	Humidity	: 57 %
Modulation Type	: GFSK	Atmospheric Pressure	: 1021 hPa

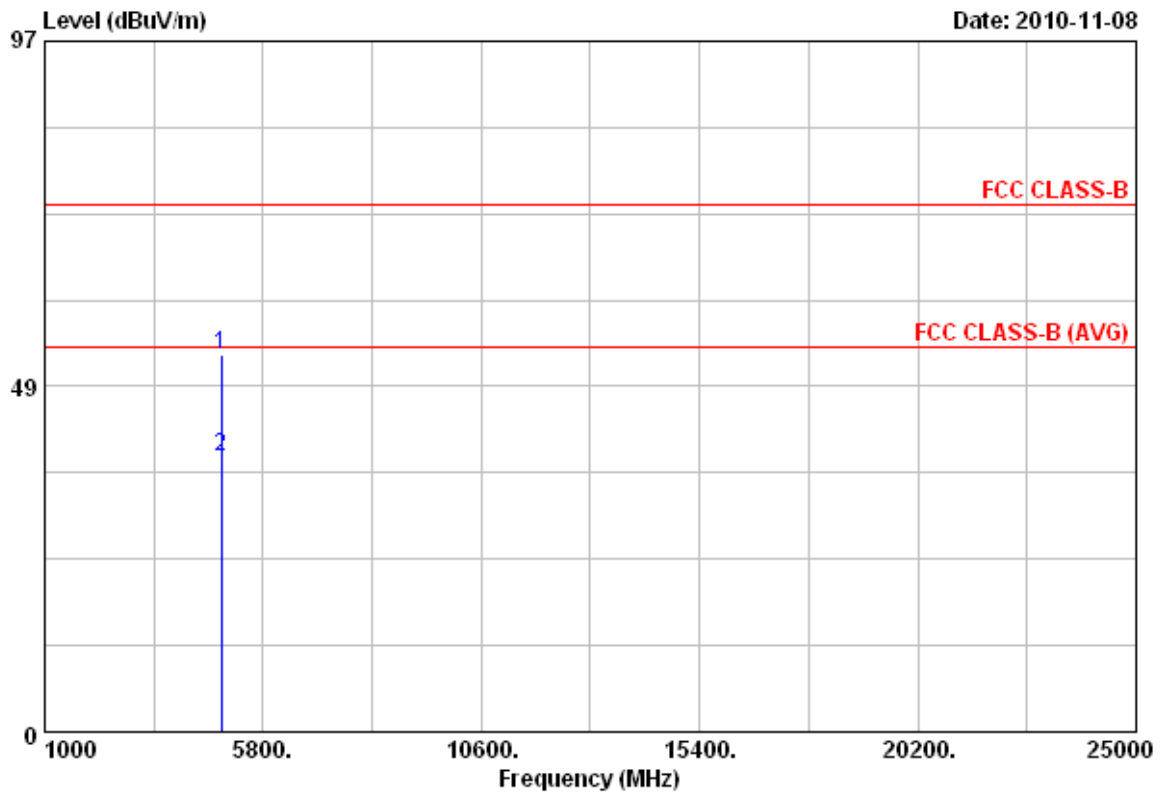

Item	Freq	Read Value	Factor	Result	Limit	Margin	Remark	Ant Pos	Tab Pos
	MHz	dBuV	dB/m	dBuV/m	dBuV/m	dB		cm	Deg
1	4880.00	40.37	12.51	52.88	74.00	-21.12	Peak	100	360
2	4880.88	26.18	12.51	38.69	54.00	-15.31	Average	100	360

Notes:

1. Result = Read Value + Factor
2. Factor = Antenna Factor + Cable Loss - Amplifier
3. The resolution bandwidth of test receiver/spectrum analyzer is 120KHz and video bandwidth is 300kHz for Peak detection and Quasi-peak detection at frequency below 1GHz.
4. The resolution bandwidth of test receiver/spectrum analyzer is 1MHz and video bandwidth is 3MHz for Peak detection at frequency above 1GHz.
5. The resolution bandwidth of test receiver/spectrum analyzer is 1MHz and video bandwidth is 10Hz for Average detection at frequency above 1GHz.
6. The other emissions is too low to be measured.



Power	: DC 3V	Pol/Phase	: HORIZONTAL
Test Mode	: Transmit	Temperature	: 26 °C
Operation Channel	: 38	Humidity	: 57 %
Modulation Type	: GFSK	Atmospheric Pressure	: 1021 hPa

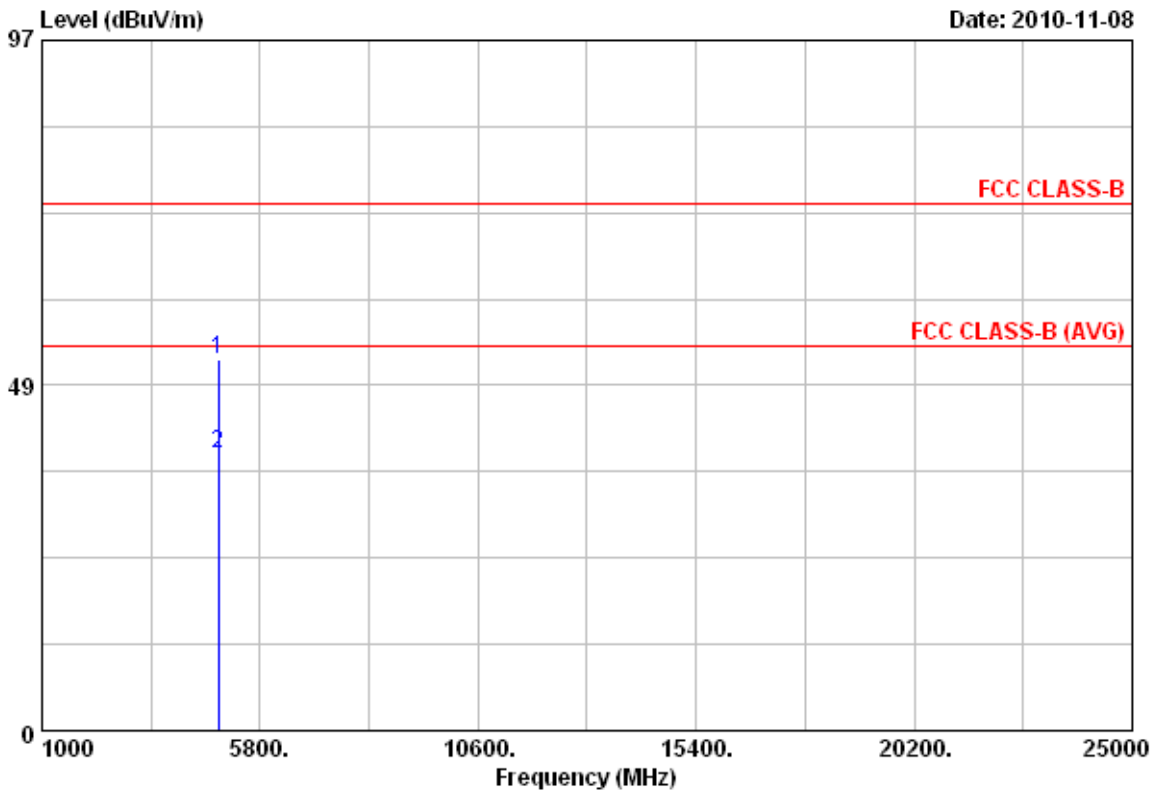

Item	Freq	Read Value	Factor	Result	Limit	Margin	Remark	Ant Pos	Tab Pos
	MHz	dBuV	dB/m	dBuV/m	dBuV/m	dB		cm	Deg
1	4880.25	39.51	12.51	52.02	74.00	-21.98	Peak	100	0
2	4880.75	26.29	12.51	38.80	54.00	-15.20	Average	100	0

Notes:

1. Result = Read Value + Factor
2. Factor = Antenna Factor + Cable Loss - Amplifier
3. The resolution bandwidth of test receiver/spectrum analyzer is 120KHz and video bandwidth is 300kHz for Peak detection and Quasi-peak detection at frequency below 1GHz.
4. The resolution bandwidth of test receiver/spectrum analyzer is 1MHz and video bandwidth is 3MHz for Peak detection at frequency above 1GHz.
5. The resolution bandwidth of test receiver/spectrum analyzer is 1MHz and video bandwidth is 10Hz for Average detection at frequency above 1GHz.
6. The other emissions is too low to be measured.



Power	: DC 3V	Pol/Phase	: VERTICAL
Test Mode	: Transmit	Temperature	: 26 °C
Operation Channel	: 75	Humidity	: 57 %
Modulation Type	: GFSK	Atmospheric Pressure	: 1021 hPa

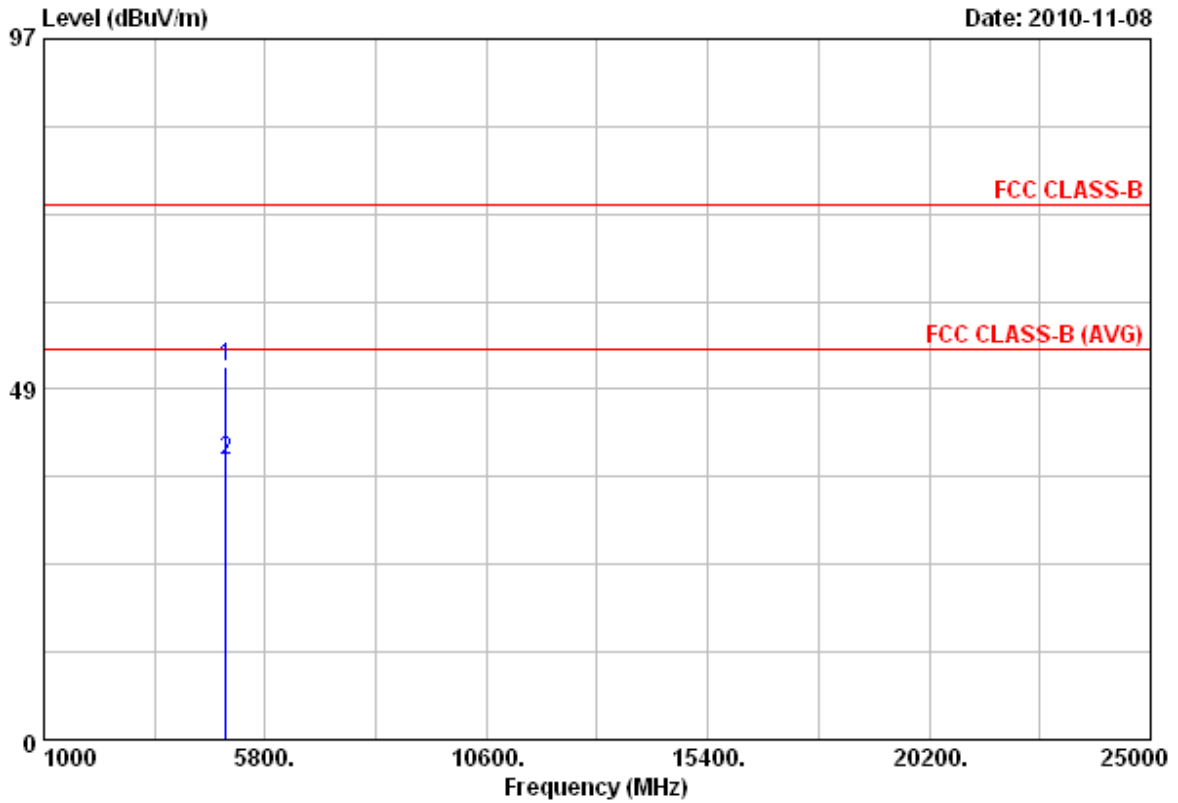

Item	Freq	Read Value	Factor	Result	Limit	Margin	Remark	Ant Pos	Tab Pos
	MHz	dBuV	dB/m	dBuV/m	dBuV/m	dB		cm	Deg
1	4954.50	38.87	12.67	51.54	74.00	-22.46	Peak	100	0
2	4954.88	25.96	12.67	38.63	54.00	-15.37	Average	100	0

Notes:

1. Result = Read Value + Factor
2. Factor = Antenna Factor + Cable Loss - Amplifier
3. The resolution bandwidth of test receiver/spectrum analyzer is 120KHz and video bandwidth is 300kHz for Peak detection and Quasi-peak detection at frequency below 1GHz.
4. The resolution bandwidth of test receiver/spectrum analyzer is 1MHz and video bandwidth is 3MHz for Peak detection at frequency above 1GHz.
5. The resolution bandwidth of test receiver/spectrum analyzer is 1MHz and video bandwidth is 10Hz for Average detection at frequency above 1GHz.
6. The other emissions is too low to be measured.



Power	: DC 3V	Pol/Phase	: HORIZONTAL
Test Mode	: Transmit	Temperature	: 26 °C
Operation Channel	: 75	Humidity	: 57 %
Modulation Type	: GFSK	Atmospheric Pressure	: 1021 hPa

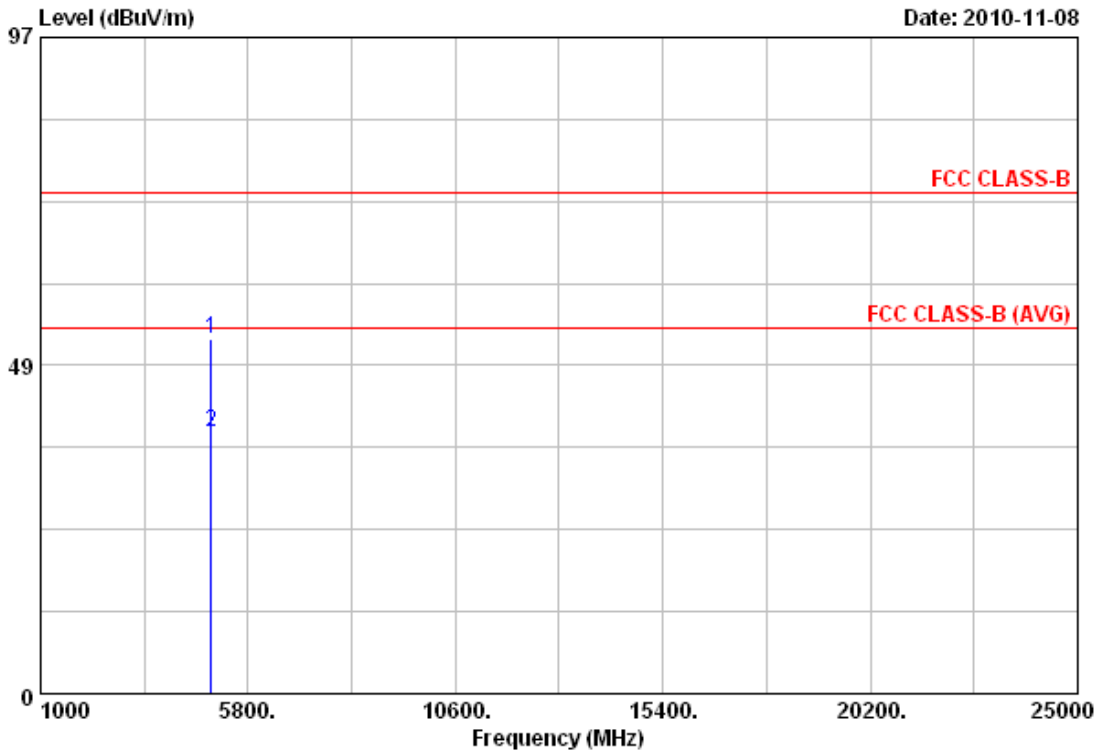

Item	Freq	Read Value	Factor	Result	Limit	Margin	Remark	Ant Pos	Tab Pos
	MHz	dBuV	dB/m	dBuV/m	dBuV/m	dB		cm	Deg
1	4954.38	39.71	12.67	52.38	74.00	-21.62	Peak	100	194
2	4954.50	25.95	12.67	38.62	54.00	-15.38	Average	100	63

Notes:

1. Result = Read Value + Factor
2. Factor = Antenna Factor + Cable Loss - Amplifier
3. The resolution bandwidth of test receiver/spectrum analyzer is 120KHz and video bandwidth is 300kHz for Peak detection and Quasi-peak detection at frequency below 1GHz.
4. The resolution bandwidth of test receiver/spectrum analyzer is 1MHz and video bandwidth is 3MHz for Peak detection at frequency above 1GHz.
5. The resolution bandwidth of test receiver/spectrum analyzer is 1MHz and video bandwidth is 10Hz for Average detection at frequency above 1GHz.
6. The other emissions is too low to be measured.

Test engineer: Ben



5.5.3. Test Result of Band Edges Measurement

Channel: 01, 2403MHz, Vertical, Peak

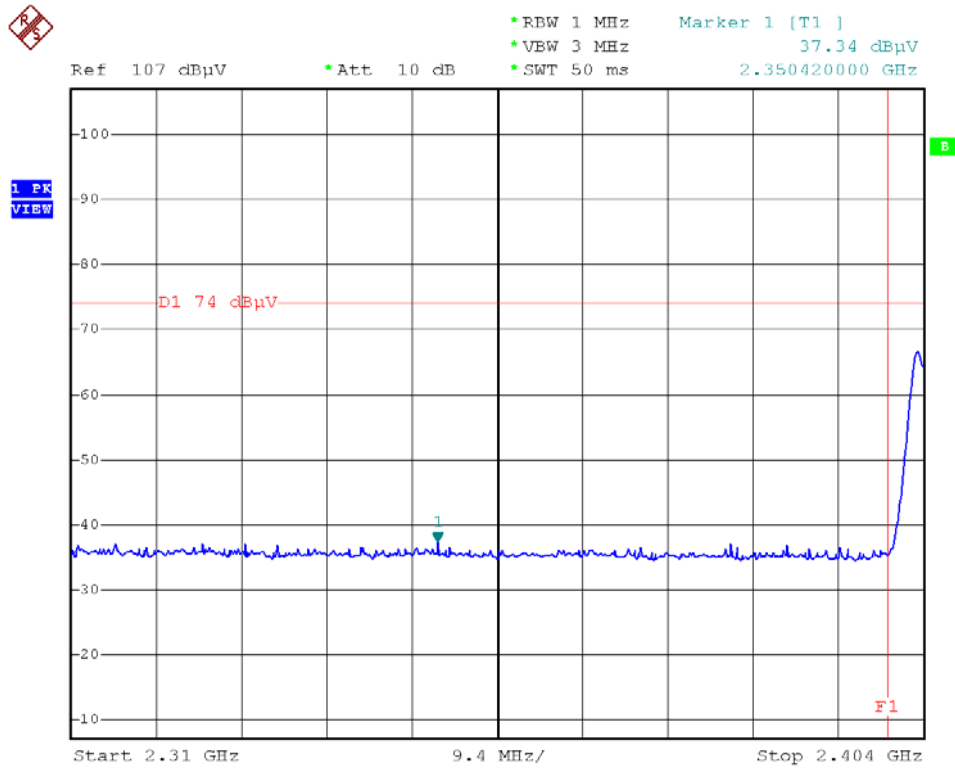

Channel: 01, 2403MHz, Vertical, Average

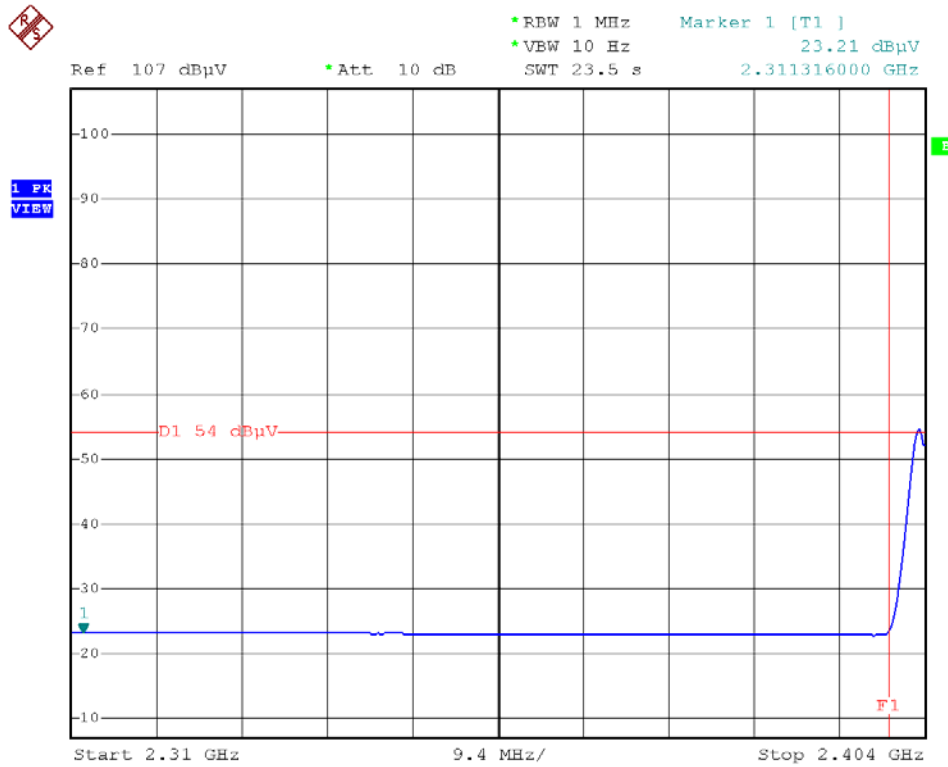



Channel: 01, 2403MHz, Horizontal, Peak

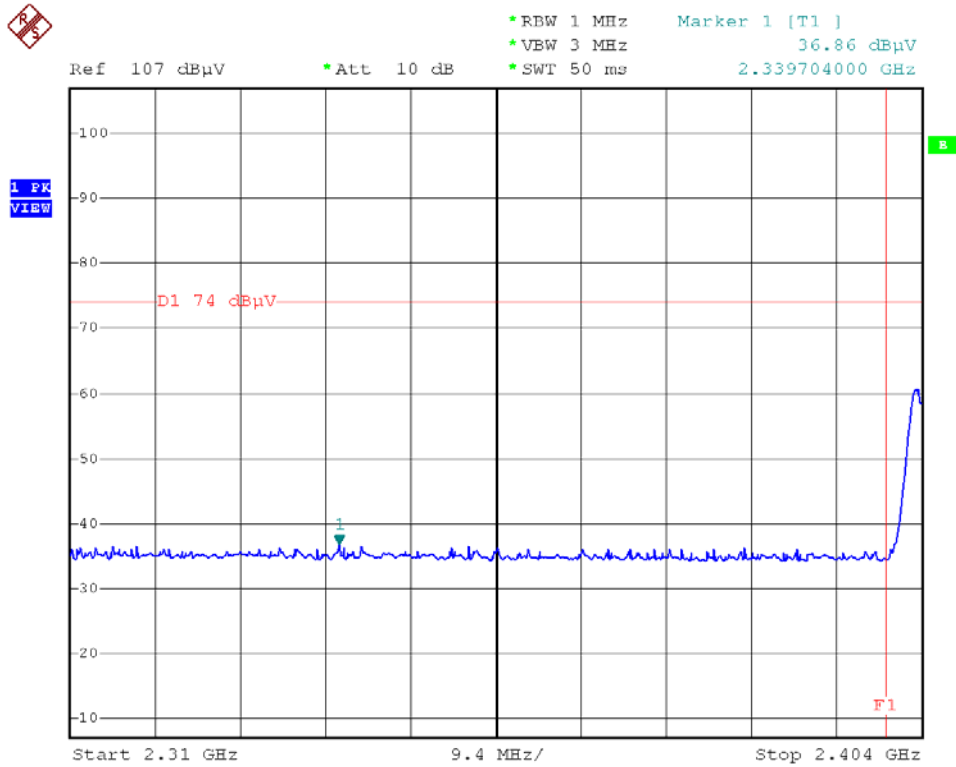

Channel: 01, 2403MHz, Horizontal, Average

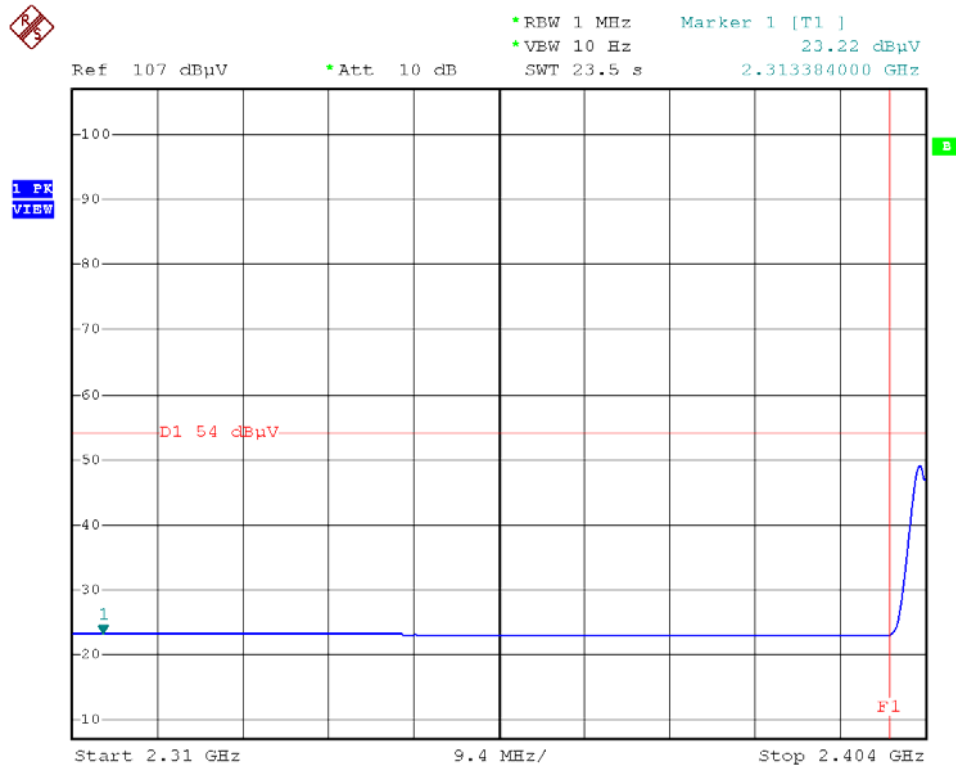



Channel: 75, 2477MHz, Vertical, Peak

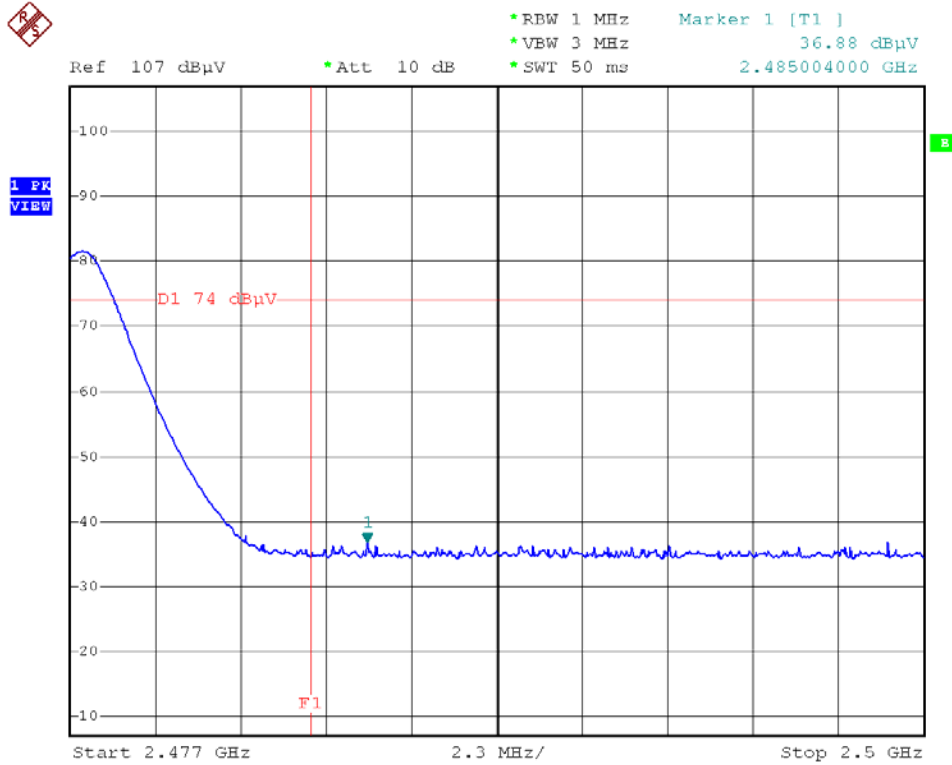

Channel: 75, 2477MHz, Vertical, Average

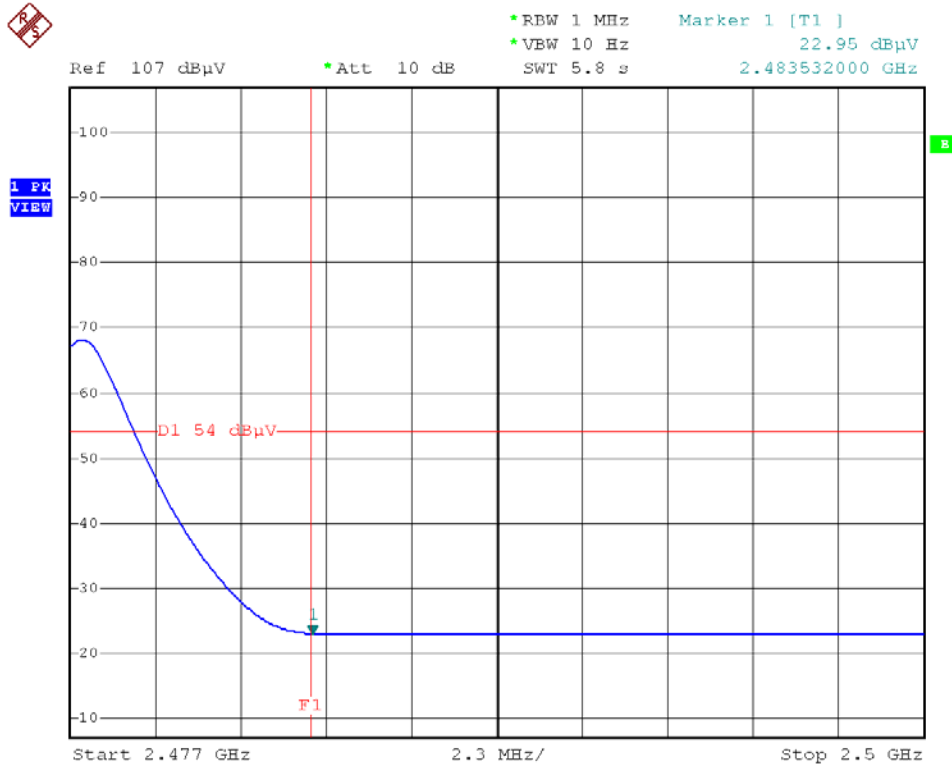



Channel: 75, 2477MHz, Horizontal, Peak

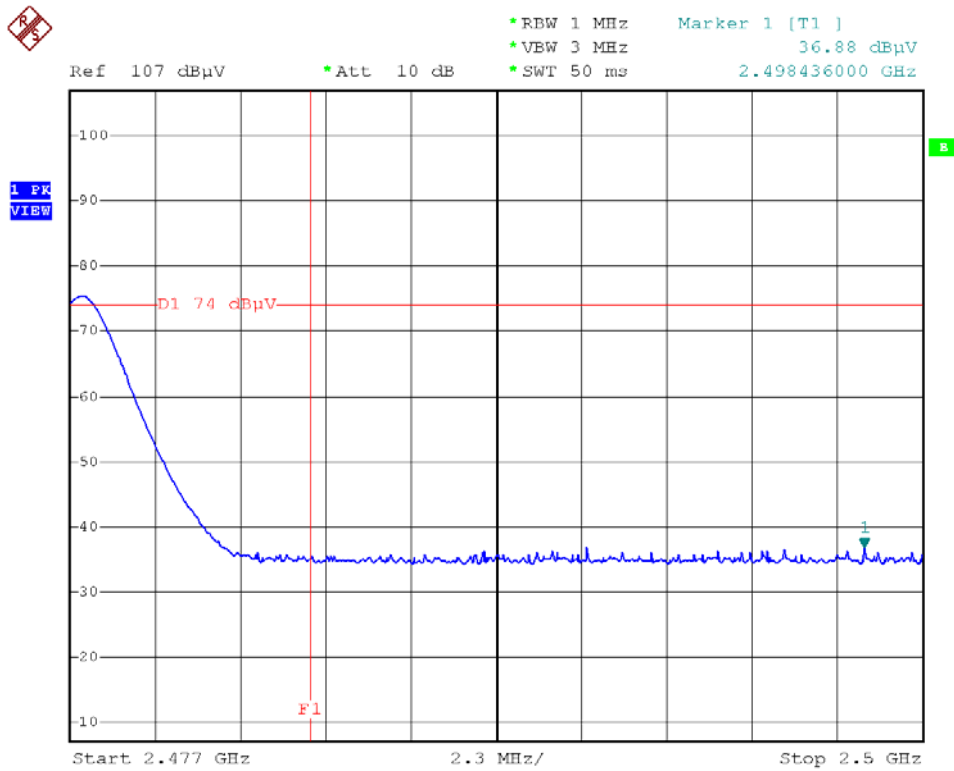

Channel: 75, 2477MHz, Horizontal, Average

