



## SAR Test Report

Product Name : MaxiSys  
Model No. : MaxiSys  
FCC ID : WQ8MAXISYSMY908

Applicant : Shenzhen Autel Intelligent Technology Co., Ltd.  
Address : East Gate, the 1st Floor of SZICC Bldg, Changuang  
Road 1089, Xili Town, Nanshan District, Shenzhen,  
China

Date of Receipt : 11/10/2013  
Date of Test : 16/10/2013  
Issued Date : 28/10/2013  
Report No. : 13AS023R-HP-US-P03V01  
Report Version : V2.0

The test results relate only to the samples tested.

The test report shall not be reproduced except in full without the written approval of Quietek Corporation.

# Test Report Certification

Issued Date: 28/10/2013

Report No.: 13AS023R-HP-US-P03V01



Product Name : MaxiSys

Applicant : Shenzhen Autel Intelligent Technology Co., Ltd.

Address : East Gate, the 1st Floor of SZICC Bldg, Chaguang Road 1089,  
Xili Town, Nanshan District, Shenzhen, China

Manufacturer : Shenzhen Autel Intelligent Technology Co., Ltd.

Address : East Gate, the 1st Floor of SZICC Bldg, Chaguang Road 1089,  
Xili Town, Nanshan District, Shenzhen, China

Model No. : MaxiSys

FCC ID : WQ8MAXISYSMY908

Brand Name : AUTEL

EUT Voltage : DC 3.7V

Applicable Standard : FCC KDB Publication 447498 D05v01r01  
FCC KDB Publication 865664 D01v01r01  
FCC KDB Publication 248227 D01v01r02  
FCC KDB Publication 616217 D04v01r01

Test Result : Max. SAR Measurement (1g)  
0.350 W/kg

Performed Location : Suzhou EMC Laboratory  
No.99 Hongye Rd., Suzhou Industrial Park Loufeng Hi-Tech  
Development Zone., Suzhou, China  
TEL: +86-512-6251-5088 / FAX: +86-512-6251-5098  
FCC Registration Number: 800392

Documented By : Alice Ni

Reviewed By : Jack Zhang

Approved By : Jame Yuan

## Laboratory Information

We, **Quietek Corporation**, are an independent EMC and safety consultancy that was established the whole facility in our laboratories. The test facility has been accredited/accepted(audited or listed) by the following related bodies in compliance with ISO 17025, EN 45001 and specified testing scope:

<b>Taiwan R.O.C.</b>	<b>:</b>	<b>BSMI, NCC, TAF</b>
<b>Germany</b>	<b>:</b>	<b>TUV Rheinland</b>
<b>Norway</b>	<b>:</b>	<b>Nemko, DNV</b>
<b>USA</b>	<b>:</b>	<b>FCC</b>
<b>Japan</b>	<b>:</b>	<b>VCCI</b>
<b>China</b>	<b>:</b>	<b>CNAS</b>

The related certificate for our laboratories about the test site and management system can be downloaded from Quietek Corporation's Web Site :<http://www.quietek.com/tw/ctg/cts/accreditations.htm>

The address and introduction of Quietek Corporation's laboratories can be founded in our Web site :  
<http://www.quietek.com/>

If you have any comments, Please don't hesitate to contact us. Our contact information is as below:

### **HsinChu Testing Laboratory :**

No.75-2, 3rd Lin, Wangye Keng, Yonghxing Tsuen, Qionglin Shiang, Hsinchu County 307, Taiwan, R.O.C.  
TEL:+886-3-592-8858 / FAX:+886-3-592-8859 E-Mail : [service@quietek.com](mailto:service@quietek.com)

### **LinKou Testing Laboratory :**

No.5-22, Ruishukeng, Linkou Dist., New Taipei City 24451, Taiwan, R.O.C.  
TEL : 886-2-8601-3788 / FAX : 886-2-8601-3789 E-Mail : [service@quietek.com](mailto:service@quietek.com)

### **Suzhou Testing Laboratory :**

No.99 Hongye Rd., Suzhou Industrial Park Loufeng Hi-Tech Development Zone., SuZhou, China  
TEL : +86-512-6251-5088 / FAX : 86-512-6251-5098 E-Mail : [service@quietek.com](mailto:service@quietek.com)

## TABLE OF CONTENTS

Description	Page
<b>1. General Information .....</b>	<b>6</b>
1.1. EUT Description .....	6
1.2. Test Environment.....	7
1.3. EUT Antenna Locations.....	7
1.4. Simultaneous Transmission Configurations.....	8
1.5. SAR Test Exclusions Applied.....	9
1.6. Power Reduction for SAR.....	10
1.7. Guidance Documents.....	10
<b>2. SAR Measurement System .....</b>	<b>11</b>
2.1. DASY5 System Description.....	11
2.1.1. Applications .....	12
2.1.2. Area Scans .....	12
2.1.3. Zoom Scan (Cube Scan Averaging) .....	12
2.1.4. Uncertainty of Inter-/Extrapolation and Averaging .....	12
2.2. DASY5 E-Field Probe.....	13
2.2.1. Isotropic E-Field Probe Specification .....	13
2.3. Boundary Detection Unit and Probe Mounting Device .....	14
2.4. DATA Acquisition Electronics (DAE) and Measurement Server.....	14
2.5. Robot.....	15
2.6. Light Beam Unit.....	15
2.7. Device Holder.....	16
2.8. SAM Twin Phantom.....	16
<b>3. Tissue Simulating Liquid .....</b>	<b>17</b>
3.1. The composition of the tissue simulating liquid .....	17
3.2. Tissue Calibration Result.....	17
3.3. Tissue Dielectric Parameters for Head and Body Phantoms.....	18
<b>4. SAR Measurement Procedure .....</b>	<b>19</b>
4.1. SAR System Validation.....	19
4.1.1. Validation Dipoles .....	19
4.1.2. Validation Result.....	19
4.2. SAR Measurement Procedure.....	21
<b>5. SAR Exposure Limits .....</b>	<b>22</b>

<b>6. Test Equipment List.....</b>	<b>23</b>
<b>7. Measurement Uncertainty.....</b>	<b>27</b>
<b>8. Conducted Power Measurement.....</b>	<b>29</b>
<b>9. Test Results.....</b>	<b>32</b>
9.1. Test Results.....	32
9.2. SAR Test Notes.....	34
<b>Appendix A. SAR System Validation Data.....</b>	<b>37</b>
<b>Appendix B. SAR measurement Data.....</b>	<b>40</b>
<b>Appendix C. Test Setup Photographs &amp; EUT Photographs.....</b>	<b>61</b>
<b>Appendix D. Probe Calibration Data.....</b>	<b>67</b>
<b>Appendix E. Dipole Calibration Data.....</b>	<b>80</b>
<b>Appendix F. DAE Calibration Data.....</b>	<b>112</b>

## 1. General Information

### 1.1. EUT Description

Product Name	MaxiSys
Model No.	MaxiSys
<b>GPS</b>	
Operate frequency	1575.42MHz
Type of modulation	BPSK
<b>Wi-Fi</b>	
Frequency Range	802.11b/g/n(20MHz): 2412 - 2462 MHz 802.11n(40MHz): 2422- 2452MHz 802.11a: 5180-5240 MHz; 5745-5825 MHz
Channel Number	802.11b/g/n(20MHz): 11 802.11n(40MHz): 7 802.11a: 9
Type of Modulation	802.11b: DSSS 802.11a/g/n: OFDM
Data Rate	802.11b: 1/2/5.5/11 Mbps 802.11g: 6/9/12/18/24/36/48/54 Mbps 802.11n: up to 65 Mbps 802.11a: 6/9/12/18/24/36/48/54 Mbps
Device Category	Mobile
RF Exposure Environment	Uncontrolled
Antenna Type	Integral Antenna
Peak Antenna Gain	2.4G : 0.68dBi 5G : 0.85dBi
<b>Bluetooth</b>	
Bluetooth Frequency	2402~2480MHz
Bluetooth Version	V2.1+EDR
Type of modulation	GFSK, Pi/4QPSK, 8DPSK
Data Rate	1Mbps, 2Mbps, 3Mbps
Antenna Gain	0.5dBi

1.2. Test Environment

Ambient conditions in the laboratory:

Items	Required	Actual
Temperature (°C)	18-25	21.5± 2
Humidity (%RH)	30-70	52

1.3. EUT Antenna Locations

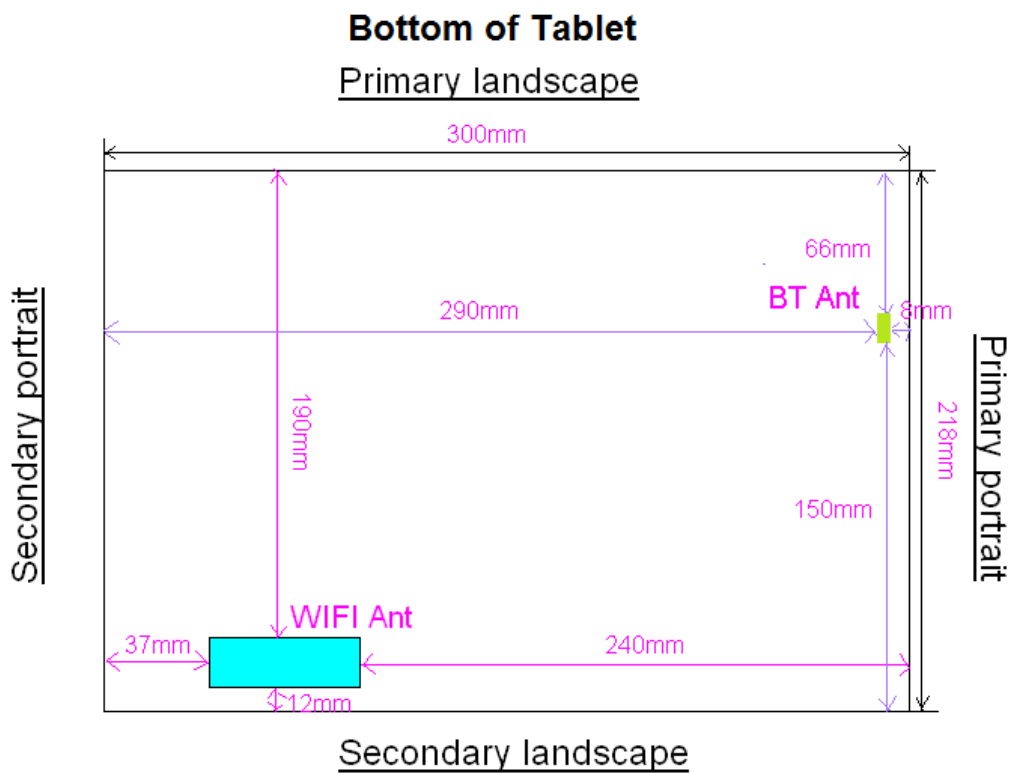

**1.4. Simultaneous Transmission Configurations**

According to FCC KDB Publication 447498 D05v01r01,transmitter are considered to be transmitting simultaneously when there is overlapping transmission, with the exception of transmissions during network hand-offs with maximum hand-off duration less than 30 seconds. This device contains multiple transmitters that may operate simultaneously, and therefore requires a simultaneously transmission analysis according to FCC KDB Publication 447498 D05v01r01 3) procedures.

**Table 1-1  
Simultaneous Transmission Scenarios**

Ref.	Simultaneous Transmit Configurations	Head	Body-Worn	Hotspot	Note
		IEEE1528 Supp C	FCC KDB447498 V05	FCC KDB941225 D06	
1	2.4GHz Wi-Fi + BT	No	Yes	No	
2	5GHz Wi-Fi + BT	No	Yes	No	



**1.5. SAR Test Exclusions Applied**

**Wi-Fi/Bluetooth**

Per FCC KDB 447498 D05v01r01, the SAR exclusion threshold for distances<50mm is defined by the following equation:

$$\frac{\text{Max Power of Channel (mW)}}{\text{Test Separation Dist (mm)}} * \sqrt{\text{Frequency(GHz)}} \leq 3.0$$

Based on the maximum conducted power of Bluetooth and the antenna to use separation distance, 2.4G SAR was required on body;

$$[(25.70\text{mW} / 5) * \sqrt{2.480}] = 8.10 > 3.0 \text{ for Body}$$

Per FCC KDB 447498 D05v01r01, the SAR exclusion threshold for distances>50mm is defined by the following equation:

$$\frac{[\text{Power allowed at numeric threshold for 50 mm in step 1}] + (\text{Test separation distance} - 50 \text{ mm}) (\text{Frequency(MHz)}/150) \text{ mW}}{\text{Test Separation Dist(mm)}} * \sqrt{\text{Frequency(GHz)}}$$

2.4G WIFI Antenna	SAR exclusion threshold( mW)	
	Sepration distances<50mm	Sepration distance>50mm
Primary landscape	--	306
Secondary landscape	23.24	--
Primary portrait	--	384
Secondary portrait	71.65	--

5.2G WIFI Antenna	SAR exclusion threshold( mW)	
	Sepration distances<50mm	Sepration distance>50mm
Primary landscape	--	232
Secondary landscape	15.79	--
Primary portrait	--	285
Secondary portrait	48.68	--

5.8G WIFI Antenna	SAR exclusion threshold( mW)	
	Sepration distances<50mm	Sepration distance>50mm
Primary landscape	--	226
Secondary landscape	14.95	--
Primary portrait	--	275
Secondary portrait	46.09	--

2.4G Bluetooth Antenna	SAR exclusion threshold( mW)	
	Sepration distances<50mm	Sepration distance>50mm
Primary landscape	--	390
Secondary landscape	--	1939
Primary portrait	15.24	--
Secondary portrait	--	4520

**1.6. Power Reduction for SAR**

There is no power reduction used for any band/mode implemented in this device for SAR purposes.

**1.7. Guidance Documents**

- 1) FCC KDB Publication 447498 D05v01r01 (General SAR Guidance)
- 2) FCC KDB Publication 865664 D01v01r01(SAR measurement 100 MHz to 6 GHz)
- 3) FCC KDB Publication 248227 D01v01r02 (SAR Considerations for 802.11 Devices)
- 4) FCC KDB Publication 616217 D04v01r01(SAR Evaluation Considerations for Laptop, Notebook, Netbook and Tablet Computers)

## 2. SAR Measurement System

### 2.1. DASY5 System Description

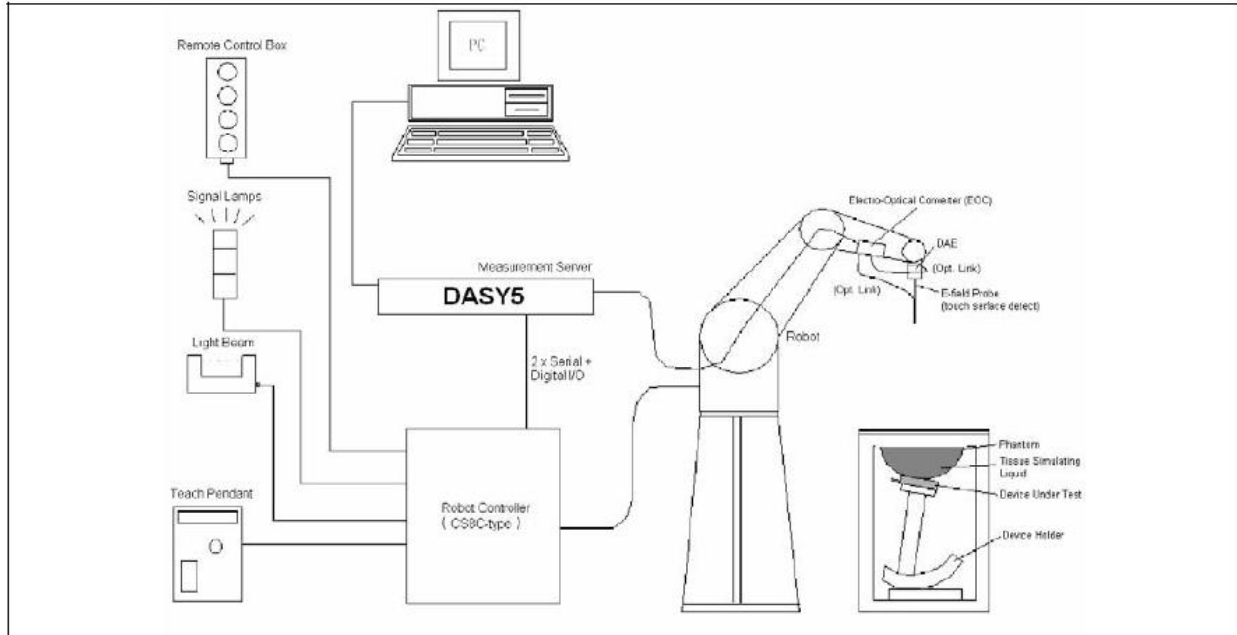

The DASY5 system for performing compliance tests consists of the following items:

- A standard high precision 6-axis robot with controller, teach pendant and software. An arm extension for accommodating the data acquisition electronics (DAE).
- A data acquisition electronics (DAE) which performs the signal amplification, signal multiplexing, AD-conversion, offset measurements, mechanical surface detection, collision detection, etc. The unit is battery powered with standard or rechargeable batteries. The signal is optically transmitted to the EOC.
- The Electro-optical converter (EOC) performs the conversion from optical to electrical signals for the digital communication to the DAE. To use optical surface detection, a special version of the EOC is required. The EOC signal is transmitted to the measurement server.
- The Light Beam used is for probe alignment. This improves the (absolute) accuracy of the probe positioning.
- A computer running WinXP and the DASY5 software.
- Remote control and teach pendant as well as additional circuitry for robot safety such as warning lamps, etc.
- The phantom, the device holder and other accessories according to the targeted measurement.

### **2.1.1. Applications**

Predefined procedures and evaluations for automated compliance testing with all worldwide standards, e.g., IEEE 1528, OET 65, IEC 62209-1, IEC 62209-2, EN 50360, EN 50383 and others.

### **2.1.2. Area Scans**

Area scans are defined prior to the measurement process being executed with a user defined variable spacing between each measurement point (integral) allowing low uncertainty measurements to be conducted. Scans defined for FCC applications utilize a 10mm<sup>2</sup> step integral, with 1mm interpolation used to locate the peak SAR area used for zoom scan assessments.

When an Area Scan has measured all reachable points, it computes the field maxima found in the scanned area, within a range of the global maximum. The range (in dB) is specified in the standards for compliance testing. For example, a 2 dB range is required in IEEE 1528-2003 and IEC 62209 standards, whereby 3 dB is a requirement when compliance is assessed in accordance with the ARIB standard (Japan).

### **2.1.3. Zoom Scan (Cube Scan Averaging)**

Zoom Scans are used to assess the peak spatial SAR values within a cubic averaging volume containing 1 g and 10 g of simulated tissue. A density of 1000 kg/m<sup>3</sup> is used to represent the head and body tissue density and not the phantom liquid density, in order to be consistent with the definition of the liquid dielectric properties, i.e. the side length of the 1 g cube is 10mm, with the side length of the 10 g cube 21,5mm.

The zoom scan integer steps can be user defined so as to reduce uncertainty, but normal practice for typical test applications utilize a physical step of 7x7x7 (5mmx5mmx5mm) providing a volume of 30mm in the X & Y axis, and 30mm in the Z axis.

### **2.1.4. Uncertainty of Inter-/Extrapolation and Averaging**

In order to evaluate the uncertainty of the interpolation, extrapolation and averaged SAR calculation algorithms of the Postprocessor, DASYS5 allows the generation of measurement grids which are artificially predefined by analytically based test functions. Therefore, the grids of area scans and zoom scans can be filled with uncertainty test data, according to the SAR benchmark functions of IEEE 1528. The three analytical functions shown in equations as below are used to describe the possible range of the expected SAR distributions for the tested handsets. The field gradients are covered by the spatially flat distribution f1, the spatially steep distribution f3 and f2 accounts for H-field cancellation on the phantom/tissue surface.

$$f_1(x, y, z) = Ae^{-\frac{z}{2a}} \cos^2 \left( \frac{\pi \sqrt{x'^2 + y'^2}}{2 \cdot 5a} \right)$$

$$f_2(x, y, z) = Ae^{-\frac{z}{a}} \frac{a^2}{a^2 + x'^2} \left( 3 - e^{-\frac{2z}{a}} \right) \cos^2 \left( \frac{\pi y'}{2 \cdot 3a} \right)$$

$$f_3(x, y, z) = A \frac{a^2}{\frac{a^2}{4} + x'^2 + y'^2} \left( e^{-\frac{2z}{a}} + \frac{a^2}{2(a + 2z)^2} \right)$$

**2.2. DASY5 E-Field Probe**

The SAR measurement is conducted with the dosimetric probe manufactured by SPEAG. The probe is specially designed and calibrated for use in liquid with high permittivity. The dosimetric probe has special calibration in liquid at different frequency. SPEAG conducts the probe calibration in compliance with international and national standards (e.g. IEEE 1528, EN 62209-1, IEC 62209, etc.) under ISO 17025. The calibration data are in Appendix D.

**2.2.1. Isotropic E-Field Probe Specification**

<b>Model</b>	EX3DV4	
<b>Construction</b>	Symmetrical design with triangular core Built-in shielding against static charges PEEK enclosure material (resistant to organic solvents, e.g., DGBE)	
<b>Frequency</b>	10 MHz to 6 GHz Linearity: ± 0.2 dB (30 MHz to 6 GHz)	
<b>Directivity</b>	± 0.3 dB in HSL (rotation around probe axis) ± 0.5 dB in tissue material (rotation normal to probe axis)	
<b>Dynamic Range</b>	10 µW/g to 100 mW/g Linearity: ± 0.2 dB (noise: typically < 1 µW/g)	
<b>Dimensions</b>	Overall length: 330 mm (Tip: 20 mm) Tip diameter: 2.5 mm (Body: 12 mm) Typical distance from probe tip to dipole centers: 1 mm	
<b>Application</b>	High precision dosimetric measurements in any exposure scenario (e.g., very strong gradient fields). Only probe which enables compliance testing for frequencies up to 6 GHz with precision of better 30%.	

**2.3. Boundary Detection Unit and Probe Mounting Device**

The DASY probes use a precise connector and an additional holder for the probe, consisting of a plastic tube and a flexible silicon ring to center the probe. The connector at the DAE is flexibly mounted and held in the default position with magnets and springs. Two switching systems in the connector mount detect frontal and lateral probe collisions and trigger the necessary software response.

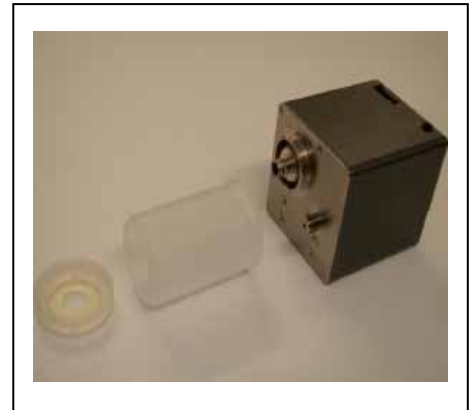

**2.4. DATA Acquisition Electronics (DAE) and Measurement Server**

The data acquisition electronics (DAE) consists of a highly sensitive electrometer-grade preamplifier with auto-zeroing, a channel and gain-switching multiplexer, a fast 16 bit AD-converter and a command decoder and control logic unit.

Transmission to the measurement server is accomplished through an optical downlink for data and status information as well as an optical uplink for commands and the clock.

The input impedance of the DAE4 is 200M Ohm; the inputs are symmetrical and floating. Common mode rejection is above 80dB.

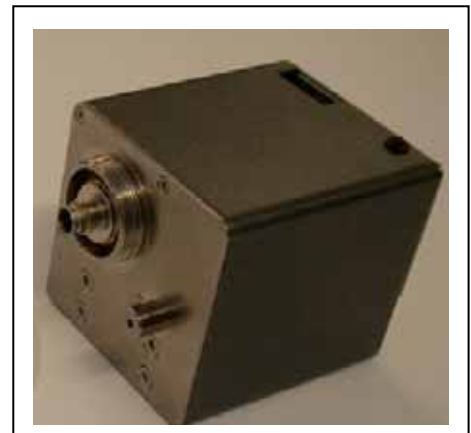

The DASY5 measurement server is based on a PC/104 CPU board with a 400MHz intel ULV Celeron, 128MB chipdisk and 128MB RAM. The necessary circuits for communication with the DAE electronics box, as well as the 16 bit AD converter system for optical detection and digital I/O interface are contained on the DASY5 I/O board, which is directly connected to the PC/104 bus of the CPU board.



**2.5. Robot**

The DASY5 system uses the high precision robots TX90 XL type out of the newer series from Stäubli SA (France). For the 6-axis controller DASY5 system, the CS8C robot controller version from Stäubli is used.

The XL robot series have many features that are important for our application:

- High precision (repeatability 0.02 mm)
- High reliability (industrial design)
- Jerk-free straight movements
- Low ELF interference (the closed metallic construction shields against motor control fields)
- 6-axis controller



**2.6. Light Beam Unit**

The light beam switch allows automatic "tooling" of the probe. During the process, the actual position of the probe tip with respect to the robot arm is measured, as well as the probe length and the horizontal probe offset. The software then corrects all movements, such that the robot coordinates are valid for the probe tip.

The repeatability of this process is better than 0.1 mm. If a position has been taught with an aligned probe, the same position will be reached with another aligned probe within 0.1 mm, even if the other probe has different dimensions. During probe rotations, the probe tip will keep its actual position.



## 2.7. Device Holder

The DASY5 device holder is designed to cope with different positions given in the standard. It has two scales for the device rotation (with respect to the body axis) and the device inclination (with respect to the line between the ear reference points). The rotation center for both scales is the ear reference point (EPR).

Thus the device needs no repositioning when changing the angles.

The DASY5 device holder has been made out of low-loss POM material having the following dielectric parameters: relative permittivity  $\epsilon_r = 3$  and loss tangent  $\delta = 0.02$ . The amount of dielectric material has been reduced in the closest vicinity of the device, since measurements have suggested that the influence of the clamp on the test results could thus be lowered.



## 2.8. SAM Twin Phantom

The SAM twin phantom is a fiberglass shell phantom with 2mm shell thickness (except the ear region where shell thickness increases to 6mm). It has three measurement areas:

- Left head
- Right head
- Flat phantom



The bottom plate contains three pair of bolts for locking the device holder. The device holder positions are adjusted to the standard measurement positions in the three sections. A white cover is provided to tap the phantom during off-periods to prevent water evaporation and changes in the liquid parameters. On the phantom top, three reference markers are provided to identify the phantom position with respect to the robot.



### 3. Tissue Simulating Liquid

#### 3.1. The composition of the tissue simulating liquid

INGREDIENT (% Weight)	2450MHz Body	5200MHz Body	5800MHz Body
Water	73.2	75.68	75.68
Salt	0.04	0.43	0.43
Sugar	0.00	0.00	0.00
HEC	0.00	0.00	0.00
Preventol	0.00	0.00	0.00
DGBE	26.7	4.42	4.42
Triton X-100	0.00	19.47	19.47

#### 3.2. Tissue Calibration Result

The dielectric parameters of the liquids were verified prior to the SAR evaluation using DASYS5 Dielectric Probe Kit and Agilent Vector Network Analyzer E5071C

Body Tissue Simulant Measurement				
Frequency [MHz]	Description	Dielectric Parameters		Tissue Temp. [°C]
		$\epsilon_r$	$\sigma$ [s/m]	
2450MHz	Reference result ± 5% window	52.7 50.07 to 55.34	1.95 1.85 to 2.05	N/A
	16-10-2013	52.24	1.96	21.0
5200MHz	Reference result ± 5% window	49 46.55 to 51.45	5.3 5.04 to 5.56	N/A
	16-10-2013	48.94	5.15	21.0
5800MHz	Reference result ± 5% window	48.2 45.79 to 50.61	6.00 5.70 to 6.30	N/A
	16-10-2013	47.29	6.04	21.0

**3.3. Tissue Dielectric Parameters for Head and Body Phantoms**

The head tissue dielectric parameters recommended by the IEEE SCC-34/SC-2 in P1528 have been incorporated in the following table. These head parameters are derived from planar layer models simulating the highest expected SAR for the dielectric properties and tissue thickness variations in a human head. Other head and body tissue parameters that have not been specified in P1528 are derived from the tissue dielectric parameters computed from the 4-Cole-Cole equations described in Reference [12] and extrapolated according to the head parameters specified in P1528.

Target Frequency (MHz)	Head		Body	
	$\epsilon_r$	$\sigma$ (S/m)	$\epsilon_r$	$\sigma$ (S/m)
150	52.3	0.76	61.9	0.80
300	45.3	0.87	58.2	0.92
450	43.5	0.87	56.7	0.94
835	41.5	0.90	55.2	0.97
900	41.5	0.97	55.0	1.05
915	41.5	0.98	55.0	1.06
1450	40.5	1.20	54.0	1.30
1610	40.3	1.29	53.8	1.40
1800 – 2000	40.0	1.40	53.3	1.52
<b>2450</b>	39.2	1.80	<b>52.7</b>	<b>1.95</b>
3000	38.5	2.40	52.0	2.73
<b>5800</b>	35.3	5.27	<b>48.2</b>	<b>6.00</b>

( $\epsilon_r$  = relative permittivity,  $\sigma$  = conductivity and  $\rho = 1000 \text{ kg/m}^3$ )

## 4. SAR Measurement Procedure

### 4.1. SAR System Validation

#### 4.1.1. Validation Dipoles

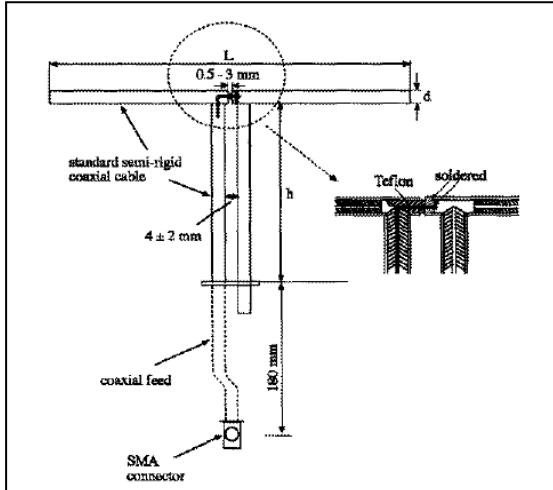

The dipoles used is based on the IEEE-1528 standard, and is complied with mechanical and electrical specifications in line with the requirements of both IEEE and FCC Supplement C. the table below provides details for the mechanical and electrical specifications for the dipoles.

Frequency	L (mm)	h (mm)	d (mm)
2450MHz	53.5	30.4	3.6
5200MHz	20.6	14.2	3.6
5800MHz	20.6	14.2	3.6

#### 4.1.2. Validation Result

System Performance Check at 2450MHz for Body				
Validation Dipole: D2450V2, SN: 839				
Frequency [MHz]	Description	SAR [w/kg] 1g	SAR [w/kg] 10g	Tissue Temp. [°C]
2450 MHz	Reference result ± 10% window	48.7 43.83 to 53.57	22.8 20.52 to 25.08	N/A
	16-10-2013	51.60	23.84	21.0
Validation Dipole: D5GHzV2, SN: 1078				
Frequency [MHz]	Description	SAR [w/kg] 1g	SAR [w/kg] 10g	Tissue Temp. [°C]
5200MHz	Reference result ± 10% window	80.6 72.54 to 88.66	23.1 20.79 to 25.41	N/A
	16-10-2013	80.6	22.8	21.0
Validation Dipole: D5GHzV2, SN: 1078				

Frequency [MHz]	Description	SAR [w/kg] 1g	SAR [w/kg] 10g	Tissue Temp. [°C]
5800 MHz	Reference result ± 10% window	73.5 66.15 to 80.85	20.3 18.27 to 22.33	N/A
	16-10-2013	72.20	20.30	21.0
Note: All SAR values are normalized to 1W forward power.				

#### 4.2. SAR Measurement Procedure

The DASYS5 calculates SAR using the following equation,

$$SAR = \frac{\sigma |E|^2}{\rho}$$

$\sigma$ : represents the simulated tissue conductivity

$\rho$ : represents the tissue density

The EUT is set to transmit at the required power in line with product specification, at each frequency relating to the LOW, MID, and HIGH channel settings.

Pre-scans are made on the device to establish the location for the transmitting antenna, using a large area scan in either air or tissue simulation fluid.

The EUT is placed against the Universal Phantom where the maximum area scan dimensions are larger than the physical size of the resonating antenna. When the scan size is not large enough to cover the peak SAR distribution, it is modified by either extending the area scan size in both the X and Y directions, or the device is shifted within the predefined area.

The area scan is then run to establish the peak SAR location (interpolated resolution set at  $1\text{mm}^2$ ) which is then used to orient the center of the zoom scan. The zoom scan is then executed and the 1g and 10g averages are derived from the zoom scan volume (interpolated resolution set at  $1\text{mm}^3$ ).

## 5. SAR Exposure Limits

SAR assessments have been made in line with the requirements of IEEE-1528, FCC Supplement C, and comply with ANSI/IEEE C95.1-1992 “Uncontrolled Environments” limits. These limits apply to a location which is deemed as “Uncontrolled Environment” which can be described as a situation where the general public may be exposed to an RF source with no prior knowledge or control over their exposure.

### Limits for General Population/Uncontrolled Exposure (W/kg)

Type Exposure	Uncontrolled Environment Limit
Spatial Peak SAR (1g cube tissue for brain or body)	1.60 W/kg
Spatial Average SAR (whole body)	0.08 W/kg
Spatial Peak SAR (10g for hands, feet, ankles and wrist)	4.00 W/kg

## 6. Test Equipment List

Instrument	Manufacturer	Model No.	Serial No.	Cali. Due Date
Stäubli Robot TX60L	Stäubli	TX60L	F10/5C90A1/A/01	only once
Controller	Stäubli	SP1	S-0034	only once
Dipole Validation Kits	Speag	D2450V2	839	2014.02.23
Dipole Validation Kits	Speag	D5GHzV2	1078	2014.02.20
SAM Twin Phantom	Speag	SAM	TP-1561/1562	N/A
Device Holder	Speag	SD 000 H01 HA	N/A	N/A
Data Acquisition Electronic	Speag	DAE4	1220	2014.01.23
E-Field Probe	Speag	EX3DV4	3710	2014.03.27
SAR Software	Speag	DASY5	V5.2 Build 162	N/A
Power Amplifier	Mini-Circuit	ZVA-183-S+	N657400950	N/A
Directional Coupler	Agilent	778D	20160	N/A
Universal Radio Communication Tester	R&S	CMU 200	117088	2014.03.30
Vector Network	Agilent	E5071C	MY48367267	2014.03.30
Signal Generator	Agilent	E4438C	MY49070163	2014.03.30
Power Meter	Anritsu	ML2495A	0905006	2013.11.10
Wide Bandwidth Sensor	Anritsu	MA2411B	0846014	2013.11.10

### Impedance Plot for D2450V2

#### 2450 Body

Calibrated impedance: 52.1  $\Omega$ ; Measured impedance: 53.4  $\Omega$  (within 5 $\Omega$ )

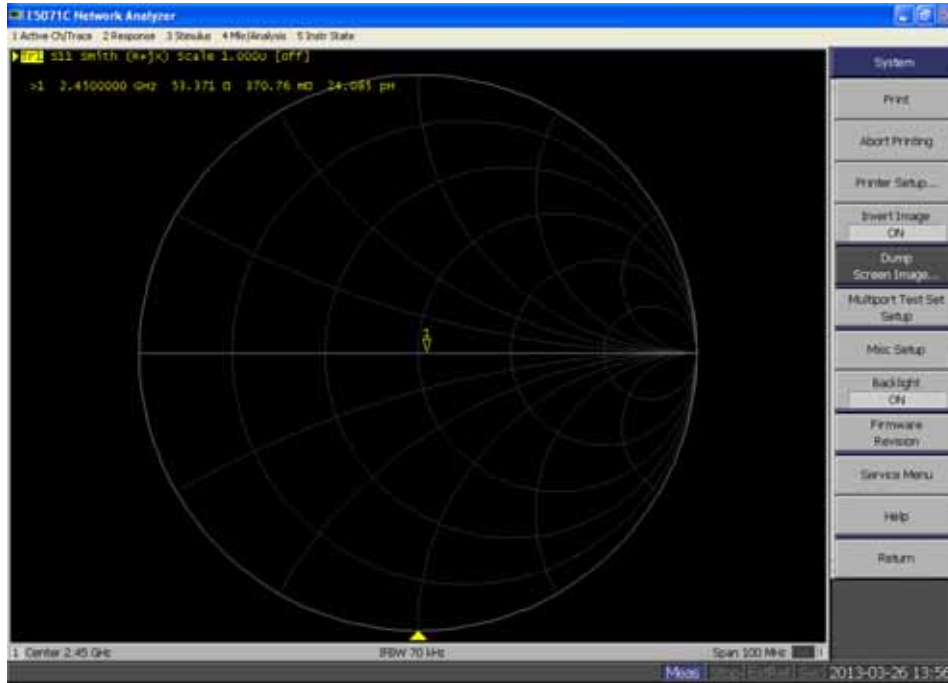

Calibrated return loss: -32.9 dB; Measured return loss: -28.4 dB (within 20%)

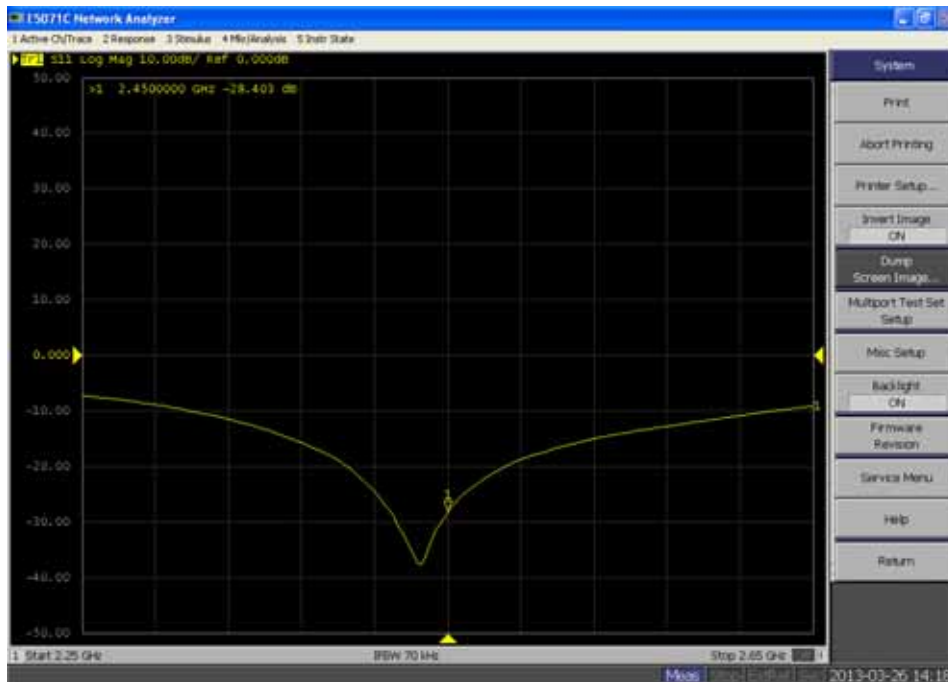



5200 Body

Calibrated impedance: 51.5 Ω; Measured impedance: 50.1 Ω (within 5Ω)

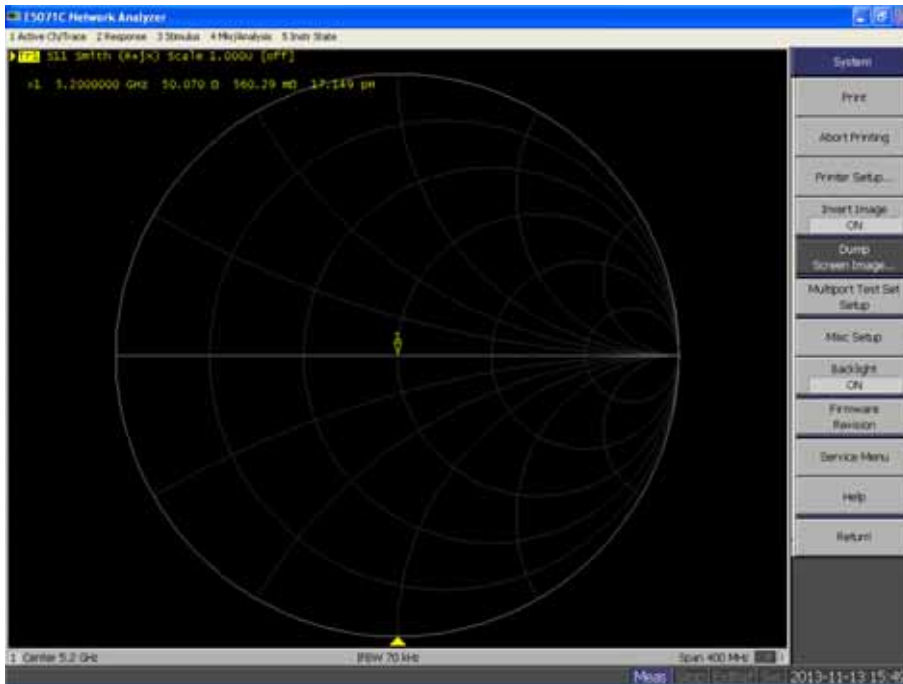

Calibrated return loss: -22 dB; Measured return loss: -20.7dB (within 20%)

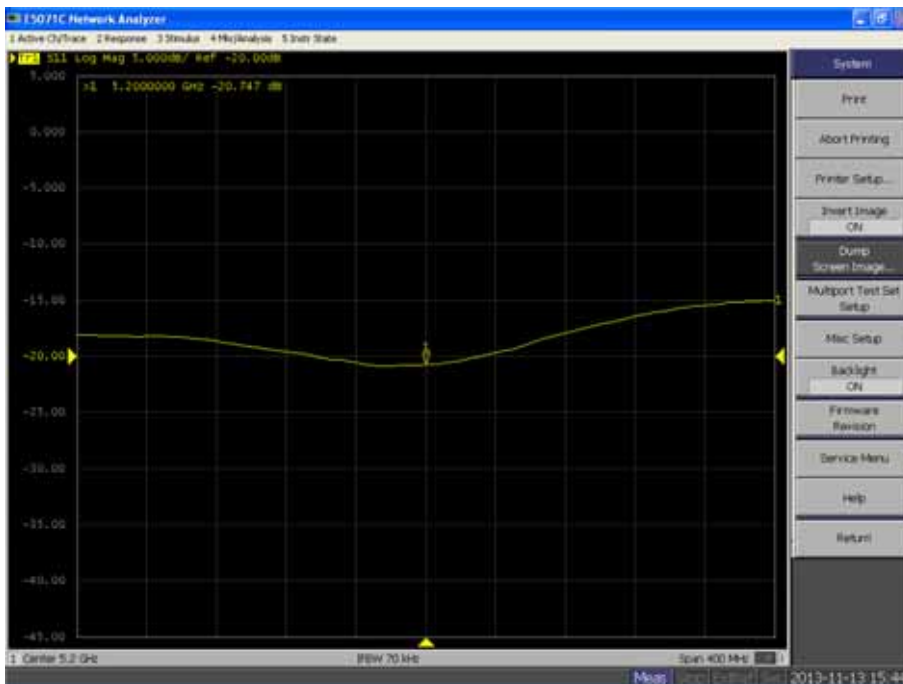

5800 Body

Calibrated impedance: 55.1  $\Omega$ ; Measured impedance: 55.9  $\Omega$  (within 5 $\Omega$ )

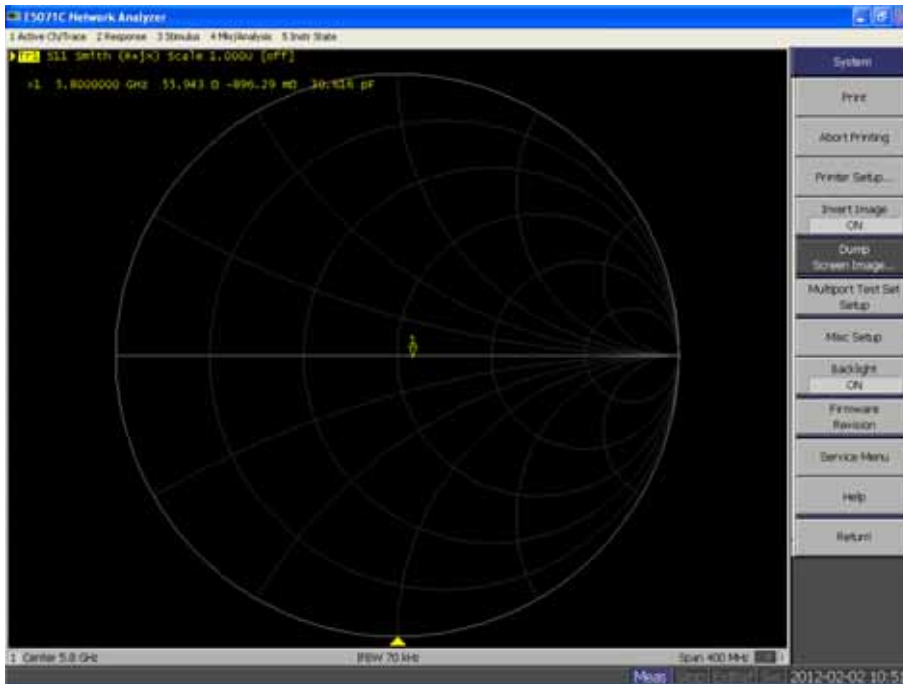

Calibrated return loss: -25.7 dB; Measured return loss: -25.7 dB (within 20%)

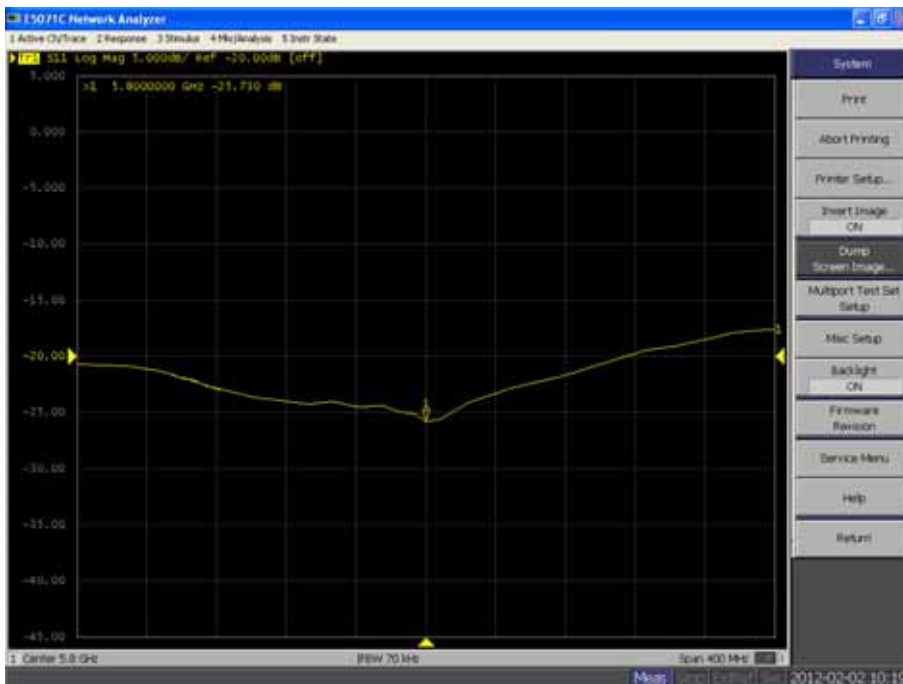

7. Measurement Uncertainty

DASY5 Uncertainty								
Measurement uncertainty for 300 MHz to 3 GHz averaged over 1 gram / 10 gram.								
Error Description	Uncert. value	Prob. Dist.	Div.	(ci) 1g	(ci) 10g	Std. Unc. (1g)	Std. Unc. (10g)	(vi) V <sub>eff</sub>
<b>Measurement System</b>								
Probe Calibration	±6.0%	N	1	1	1	±6.0%	±6.0%	∞
Axial Isotropy	±4.7%	R	√3	0.7	0.7	±1.9%	±1.9%	∞
Hemispherical Isotropy	±9.6%	R	√3	0.7	0.7	±3.9%	±3.9%	∞
Boundary Effects	±1.0%	R	√3	1	1	±0.6%	±0.6%	∞
Linearity	±4.7%	R	√3	1	1	±2.7%	±2.7%	∞
System Detection Limits	±1.0%	R	√3	1	1	±0.6%	±0.6%	∞
Readout Electronics	±0.3%	N	1	1	1	±0.3%	±0.3%	∞
Response Time	±0.8%	R	√3	1	1	±0.5%	±0.5%	∞
Integration Time	±2.6%	R	√3	1	1	±1.5%	±1.5%	∞
RF Ambient Noise	±3.0%	R	√3	1	1	±1.7%	±1.7%	∞
RF Ambient Reflections	±3.0%	R	√3	1	1	±1.7%	±1.7%	∞
Probe Positioner	±0.4%	R	√3	1	1	±0.2%	±0.2%	∞
Probe Positioning	±2.9%	R	√3	1	1	±1.7%	±1.7%	∞
Max. SAR Eval.	±1.0%	R	√3	1	1	±0.6%	±0.6%	∞
<b>Test Sample Related</b>								
Device Positioning	±2.9%	N	1	1	1	±2.9%	±2.9%	145
Device Holder	±3.6%	N	1	1	1	±3.6%	±3.6%	5
Power Drift	±5.0%	R	√3	1	1	±2.9%	±2.9%	∞
<b>Phantom and Setup</b>								
Phantom Uncertainty	±4.0%	R	√3	1	1	±2.3%	±2.3%	∞
Liquid Conductivity (target)	±5.0%	R	√3	0.64	0.43	±1.8%	±1.2%	∞
Liquid Conductivity (meas.)	±2.5%	N	1	0.64	0.43	±1.6%	±1.1%	∞
Liquid Permittivity (target)	±5.0%	R	√3	0.6	0.49	±1.7%	±1.4%	∞
Liquid Permittivity (meas.)	±2.5%	N	1	0.6	0.49	±1.5%	±1.2%	∞
<b>Combined Std. Uncertainty</b>						±11.0%	±10.8%	387
<b>Expanded STD Uncertainty</b>						±22.0%	±21.5%	

DASY5 Uncertainty								
Measurement uncertainty for 3 GHz to 6 GHz averaged over 1 gram / 10 gram.								
Error Description	Uncert. value	Prob. Dist.	Div.	(ci) 1g	(ci) 10g	Std. Unc. (1g)	Std. Unc. (10g)	(vi) V <sub>eff</sub>
<b>Measurement System</b>								
Probe Calibration	±6.55%	N	1	1	1	±6.55%	±6.55%	∞
Axial Isotropy	±4.7%	R	√3	0.7	0.7	±1.9%	±1.9%	∞
Hemispherical Isotropy	±9.6%	R	√3	0.7	0.7	±3.9%	±3.9%	∞
Boundary Effects	±2.0%	R	√3	1	1	±1.2%	±1.2%	∞
Linearity	±4.7%	R	√3	1	1	±2.7%	±2.7%	∞
System Detection Limits	±1.0%	R	√3	1	1	±0.6%	±0.6%	∞
Readout Electronics	±0.3%	N	1	1	1	±0.3%	±0.3%	∞
Response Time	±0.8%	R	√3	1	1	±0.5%	±0.5%	∞
Integration Time	±2.6%	R	√3	1	1	±1.5%	±1.5%	∞
RF Ambient Noise	±3.0%	R	√3	1	1	±1.7%	±1.7%	∞
RF Ambient Reflections	±3.0%	R	√3	1	1	±1.7%	±1.7%	∞
Probe Positioner	±0.8%	R	√3	1	1	±0.5%	±0.5%	∞
Probe Positioning	±9.9%	R	√3	1	1	±5.7%	±5.7%	∞
Max. SAR Eval.	±4.0%	R	√3	1	1	±2.3%	±2.3%	∞
<b>Test Sample Related</b>								
Device Positioning	±2.9%	N	1	1	1	±2.9%	±2.9%	145
Device Holder	±3.6%	N	1	1	1	±3.6%	±3.6%	5
Power Drift	±5.0%	R	√3	1	1	±2.9%	±2.9%	∞
<b>Phantom and Setup</b>								
Phantom Uncertainty	±4.0%	R	√3	1	1	±2.3%	±2.3%	∞
Liquid Conductivity (target)	±5.0%	R	√3	0.64	0.43	±1.8%	±1.2%	∞
Liquid Conductivity (meas.)	±2.5%	N	1	0.64	0.43	±1.6%	±1.1%	∞
Liquid Permittivity (target)	±5.0%	R	√3	0.6	0.49	±1.7%	±1.4%	∞
Liquid Permittivity (meas.)	±2.5%	N	1	0.6	0.49	±1.5%	±1.2%	∞
<b>Combined Std. Uncertainty</b>						±12.8%	±12.6%	330
<b>Expanded STD Uncertainty</b>						±25.6%	±25.2%	

## 8. Conducted Power Measurement

### WLAN output power

Test Mode	Channel No.	Frequency (MHz)	Average Power (dBm)	Max. Power (dBm)	Scaling Factor
802.11b	01	2412	14.62	15.0	1.091
	06	2437	14.75	15.0	1.059
	11	2462	14.92	15.0	1.019
802.11g	01	2412	13.98	14.5	1.127
	06	2437	14.33	14.5	1.040
	11	2462	14.42	14.5	1.019
802.11n (20MHz)	01	2412	14.08	14.5	1.102
	06	2437	14.01	14.5	1.119
	11	2462	14.05	14.5	1.109
802.11n (40MHz)	03	2422	14.82	15.0	1.042
	06	2437	14.78	15.0	1.052
	09	2452	14.76	15.0	1.057

Note1: Justification for reduced test configurations for Wi-Fi channels per KDB Publication 248227 D01v01r02.

2: For 2.4 GHz, highest average RF output power channel for the lowest data rate for IEEE 802.11b were selected for SAR evaluation. Other IEEE 802.11 modes (including 802.11g/n) were not investigated since the average output powers over all channels and data rates were not more than 0.25 dB higher than the tested channel in the lowest data rate of IEEE 802.11b mode.

3: When the maximum extrapolated peak SAR of the zoom scan for the maximum output channel is <1.6 W/kg and the reported 1g averaged SAR is <0.8 W/kg, SAR testing on other channels is not required. Otherwise, the other default (or corresponding required) test channels were additionally tested using the lowest data rate.

4: The bolded channel above was tested for SAR.

Test Mode		Channel No.	Frequency (MHz)	Average Power (dBm)	Max. Power (dBm)	Scaling Factor
802.11a	5.2G	36	5180	13.57	14.0	1.104
		40	5200	13.35	14.0	1.161
		44	5220	13.27	14.0	1.183
		48	5240	13.24	14.0	1.191
	5.8G	149	5745	12.70	14.0	1.349
		153	5765	12.80	14.0	1.318
		157	5785	12.87	14.0	1.297
		161	5805	12.77	14.0	1.327
		165	5825	12.72	14.0	1.343

Test Mode		Channel No.	Frequency (MHz)	Average Power (dBm)	Max. Power (dBm)	Scaling Factor
802.11 n(20MHZ)	5.2G	36	5180	13.51	14.0	1.119
		40	5200	13.32	14.0	1.169
		44	5220	13.27	14.0	1.183
		48	5240	13.16	14.0	1.213
	5.8G	149	5745	13.15	14.0	1.216
		153	5765	13.16	14.0	1.213
		157	5785	13.15	14.0	1.216
		161	5805	13.13	14.0	1.222
		165	5825	13.14	14.0	1.219

Test Mode		Channel No.	Frequency (MHz)	Average Power (dBm)	Max. Power (dBm)	Scaling Factor
802.11 n(40MHZ)	5.2G	36	5180	13.65	14.0	1.084
		44	5220	13.46	14.0	1.132
	5.8G	149	5745	13.64	14.0	1.086
		157	5785	13.63	14.0	1.089

Note: According to the manufacturer, the DFS frequencies from 5260-5700MHz are not supported.

**BT output power**

Test Mode	Channel No.	Frequency (MHz)	Average Power (dBm)	Max. Power (dBm)	Scaling Factor
DH5	01	2402	13.80	14.5	1.175
	40	2441	13.70	14.5	1.202
	78	2480	14.10	14.5	1.096
2DH5	01	2402	3.60	4.0	1.096
	40	2441	3.50	4.0	1.122
	78	2480	3.60	4.0	1.096
3DH5	01	2402	5.10	5.5	1.096
	40	2441	4.90	5.5	1.148
	78	2480	4.80	5.5	1.175

## 9. Test Results

### 9.1. Test Results

SAR MEASUREMENT									
Ambient Temperature (°C) : 21.5 ± 2					Relative Humidity (%): 52				
Liquid Temperature (°C) : 21.0 ± 2					Depth of Liquid (cm):>15				
Product: MaxiSys									
Test Mode: 802.11b									
Test Position Body at 0mm	Antenna Position	Frequency		Frame Power (dBm)	Power Drift (<±0.2)	SAR 1g (W/kg)	Scaling Factor	Scaled SAR 1g (W/kg)	Limit (W/kg)
		Channel	MHz						
Bottom	Fixed	01	2412	14.62	-0.08	0.192	1.091	0.209	1.6
Secondary landscape	Fixed	01	2412	14.62	0.07	0.065	1.091	0.071	1.6
Bottom	Fixed	06	2437	14.75	-0.18	0.171	1.059	0.181	1.6
Bottom	Fixed	11	2462	14.92	-0.02	0.157	1.019	0.160	1.6
Test Mode: 802.11a									
Bottom	Fixed	36	5180	13.57	0.10	0.262	1.104	0.289	1.6
Secondary landscape	Fixed	36	5180	13.57	0.14	0.104	1.104	0.115	1.6
Bottom	Fixed	44	5220	13.27	-0.06	0.296	1.183	0.350	1.6
Bottom	Fixed	153	5765	12.80	-0.01	0.164	1.318	0.216	1.6
Bottom	Fixed	157	5785	12.87	-0.03	0.145	1.297	0.188	1.6
Bottom	Fixed	161	5805	12.77	-0.03	0.165	1.327	0.219	1.6
Test Mode: 5G n(20MHz)									
Bottom	Fixed	36	5180	13.51	-0.07	0.244	1.119	0.273	1.6
Secondary landscape	Fixed	36	5180	13.51	0.18	0.151	1.119	0.169	1.6
Bottom	Fixed	153	5765	13.16	0.18	0.169	1.213	0.205	1.6
Test Mode: 5G n(40MHz)									
Bottom	Fixed	36	5180	13.65	0.11	0.253	1.084	0.274	1.6
Secondary landscape	Fixed	36	5180	13.51	-0.17	0.174	1.119	0.195	1.6
Bottom	Fixed	149	5745	13.64	-0.14	0.164	1.086	0.178	1.6
Note: when the 1-g SAR is ≤ 0.8 W/kg, testing for low and high channel is optional, refer to KDB 447498.									



SAR MEASUREMENT									
Ambient Temperature (°C) : 21.5 ± 2					Relative Humidity (%): 52				
Liquid Temperature (°C) : 21.0 ± 2					Depth of Liquid (cm):>15				
Product: MaxiSys									
Test Mode: Bluetooth									
Test Position Body at 0mm	Antenna Position	Frequency		Frame Power (dBm)	Power Drift (<±0.2)	SAR 1g (W/kg)	Scaling Factor	Scaled SAR 1g (W/kg)	Limit (W/kg)
		Channel	MHz						
Bottom	Fixed	78	2480	14.10	0.05	0.016	1.096	0.018	1.6
Primary portrait	Fixed	78	2480	14.10	0.09	0.019	1.096	0.021	1.6
Note: when the 1-g SAR is ≤ 0.8 W/kg, testing for low and high channel is optional, refer to KDB 447498.									

## 9.2. SAR Test Notes

### General Notes:

1. Batteries are fully charged at the beginning of the SAR measurements.
2. Liquid tissue depth was at least 15.0 cm for all frequencies.
3. The manufacturer has confirmed that the device(s) tested have the same physical, mechanical and thermal characteristics and are within operational tolerances expected for production units.
4. SAR results were scaled to the maximum allowed power to demonstrate compliance per FCC KDB Publication 447498 D05v01r01.
5. Per FCC KDB 616217 D04 Section 4.3, SAR tests are required for the back surface and edges of the tablet with the tablet touching the phantom. The SAR Exclusion Threshold in FCC KDB 447498 D05v01r01 was applied to determine SAR test exclusion for adjacent edge configurations. SAR tests were required for bottom and secondary landscape for the WLAN antenna and bottom and primary portrait for the BT Antenna.

### WLAN/BT Notes:

1. Justification for reduced test configurations for Wi-Fi channels per KDB Publication 248227 D01v01r02 and April 2010 FCC/TCB Meeting Notes for 2.4 GHz Wi-Fi: Highest average RF output power channel for the lowest data rate was selected for SAR evaluation in 802.11b. Other IEEE 802.11 modes (including 802.11g/n) were not investigated since the average output powers over all channels and data rates were not more than 0.25 dB higher than the tested channel in the lowest data rate of IEEE 802.11b mode.
2. When the maximum extrapolated peak SAR of the zoom scan for the maximum output channel is <1.6 W/kg and the reported 1g averaged SAR is <0.8 W/kg, SAR testing on other default channels is not required.

**Simultaneous Transmission Analysis**

Simultaneous Transmission Scenario with Bluetooth (Body at 0mm)

Simult Tx	Configuration	2.4G WLAN SAR (W/kg)	Bluetooth SAR (W/kg)	$\Sigma$ SAR (W/kg)
Body	Bottom	0.209	0.018	0.227
	Primary landscape	--	--	--
	Secondary landscape	0.071	--	0.071
	Primary portrait	--	0.021	0.021
	Secondary portrait	--	--	--
Simult Tx	Configuration	5G WLAN SAR (W/kg)	Bluetooth SAR (W/kg)	$\Sigma$ SAR (W/kg)
Body	Bottom	0.350	0.018	0.368
	Primary landscape	--	--	--
	Secondary landscape	0.195	--	0.195
	Primary portrait	--	0.021	0.021
	Secondary portrait	--	--	--

**Simultaneous Transmission Conclusion**

The above numerical summed SAR results for all the worst-case simultaneous transmission conditions were below the SAR limit. Therefore, the above analysis is sufficient to determine that simultaneous transmission cases will not exceed the SAR limit and therefore no measured volumetric simultaneous SAR summation is required per FCC KDB Publication 447498 D05v01r01.

**Appendix A. SAR System Validation Data**

**Date/Time: 16-10-2013**

Test Laboratory: QuieTek Lab

System Check Body 2450MHz

**DUT: Dipole 2450 MHz D2450V2; Type: D2450V2**

Communication System: CW; Communication System Band: Exported from older format (data unavailable - please correct).; Duty Cycle: 1:1; Frequency: 2450 MHz; Medium parameters used:  $f = 2450$  MHz;  $\sigma = 1.96$  mho/m;  $\epsilon_r = 52.24$ ;  $\rho = 1000$  kg/m<sup>3</sup>; Phantom section: Flat Section; Input Power=250mW

Ambient temperature (°C): 21.5, Liquid temperature (°C): 21.0

DASY5 Configuration:

- Probe: EX3DV4 - SN3710; ConvF(7.08, 7.08, 7.08); Calibrated: 27/03/2013;
- Sensor-Surface: 4mm (Mechanical Surface Detection)
- Electronics: DAE4 Sn1220; Calibrated: 24/01/2013
- Phantom: SAM2; Type: SAM; Serial: TP1562
- Measurement SW: DASY52, Version 52.8 (1); SEMCAD X Version 14.6.5 (6469)

**Configuration/Body 2450MHz/Area Scan (7x11x1):** Measurement grid: dx=10mm, dy=10mm

Maximum value of SAR (measured) = 14.6 mW/g

**Configuration/Body 2450MHz/Zoom Scan (7x7x7)/Cube 0:** Measurement grid: dx=5mm, dy=5mm, dz=5mm, Reference Value = 86.507 V/m; Power Drift = 0.01 dB

Peak SAR (extrapolated) = 26.721 mW/g

**SAR(1 g) = 12.9 mW/g; SAR(10 g) = 5.96 mW/g** Maximum value of SAR (measured) = 14.9 mW/g

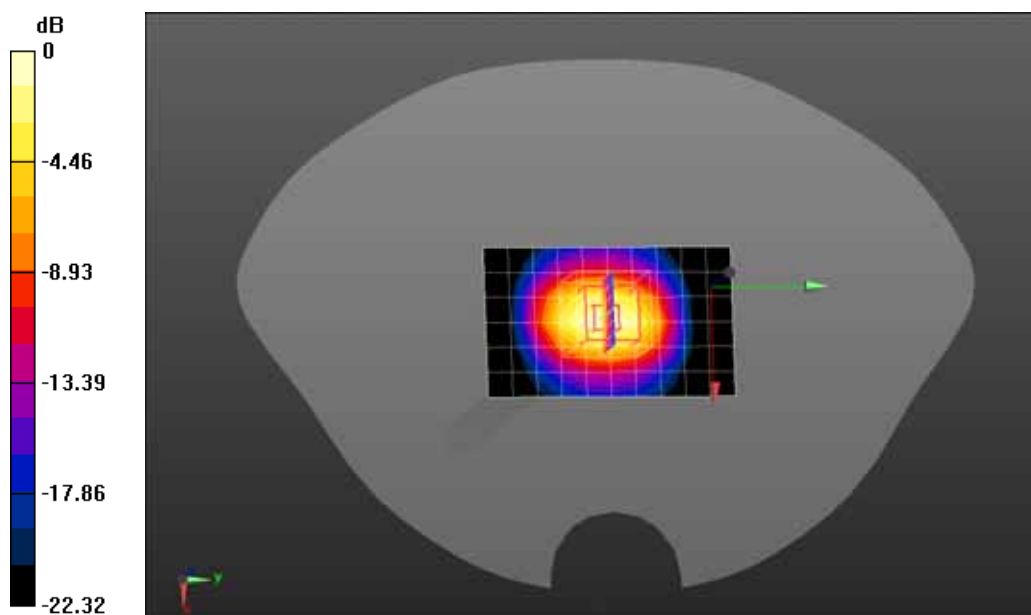

0 dB = 14.9 mW/g = 23.46 dB mW/g

Date/Time: 16-10-2013

Test Laboratory: QuieTek Lab

System Check Body 5200MHz

**DUT: Dipole D5GHzV2; Type: D5GHzV2**

Communication System: CW; Communication System Band: 5GHz; Duty Cycle: 1:1; Frequency: 5200 MHz;  
 Medium parameters used:  $f = 5200 \text{ MHz}$ ;  $\sigma = 5.15 \text{ mho/m}$ ;  $\epsilon_r = 48.94$ ;  $\rho = 1000 \text{ kg/m}^3$ ; Phantom section:  
 Flat Section ; Input Power=100mW

Ambient temperature (°C): 21.5, Liquid temperature (°C): 21.0

DASY5 Configuration:

- Probe: EX3DV4 - SN3710; ConvF(4.32, 4.32, 4.32); Calibrated: 27/03/2013;
- Sensor-Surface: 2mm (Mechanical Surface Detection)
- Electronics: DAE4 Sn1220; Calibrated: 24/01/2013
- Phantom: SAM1; Type: SAM; Serial: TP1561
- Measurement SW: DASY52, Version 52.8 (1); SEMCAD X Version 14.6.5 (6469)

**Configuration/Body 5200MHz/Area Scan (5x8x1):** Measurement grid: dx=10mm, dy=10mm

Maximum value of SAR (measured) = 15.6 mW/g

**Configuration/Body 5200MHz/Zoom Scan (8x8x10)/Cube 0:** Measurement grid: dx=4mm, dy=4mm, dz=2.5mm, Reference Value = 38.204 V/m; Power Drift = 0.01 dB

Peak SAR (extrapolated) = 30.843 mW/g

**SAR(1 g) = 8.06 mW/g; SAR(10 g) = 2.28 mW/g** Maximum value of SAR (measured) = 16.0 mW/g

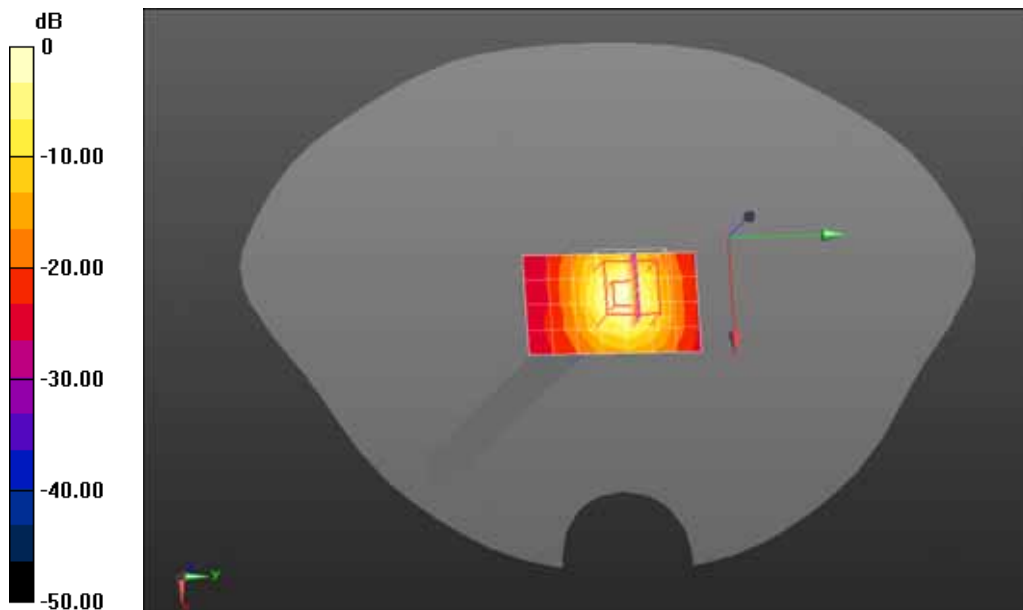

0 dB = 16.0 mW/g = 24.08 dB mW/g

Date/Time: 16-10-2013

Test Laboratory: QuieTek Lab

System Check Body 5800MHz

**DUT: Dipole D5GHzV2; Type: D5GHzV2**

Communication System: CW; Communication System Band: 5GHz; Duty Cycle: 1:1; Frequency: 5800 MHz;  
 Medium parameters used:  $f = 5800 \text{ MHz}$ ;  $\sigma = 6.04 \text{ mho/m}$ ;  $\epsilon_r = 47.29$ ;  $\rho = 1000 \text{ kg/m}^3$ ; Phantom section:  
 Flat Section; Input Power=100mW

Ambient temperature (°C): 21.5, Liquid temperature (°C): 21.0

DASY5 Configuration:

- Probe: EX3DV4 - SN3710; ConvF(4.05, 4.05, 4.05); Calibrated: 27/03/2013;
- Sensor-Surface: 2mm (Mechanical Surface Detection)
- Electronics: DAE4 Sn1220; Calibrated: 24/01/2013
- Phantom: SAM1; Type: SAM; Serial: TP1561
- Measurement SW: DASY52, Version 52.8 (1); SEMCAD X Version 14.6.5 (6469)

**Configuration/Body 5800MHz/Area Scan (5x8x1):** Measurement grid: dx=10mm, dy=10mm

Maximum value of SAR (measured) = 13.8 mW/g

**Configuration/Body 5800MHz/Zoom Scan (8x8x10)/Cube 0:** Measurement grid: dx=4mm, dy=4mm, dz=2.5mm, Reference Value = 31.985 V/m; Power Drift = 0.09 dB

Peak SAR (extrapolated) = 30.593 mW/g

**SAR(1 g) = 7.22 mW/g; SAR(10 g) = 2.03 mW/g** Maximum value of SAR (measured) = 14.4 mW/g

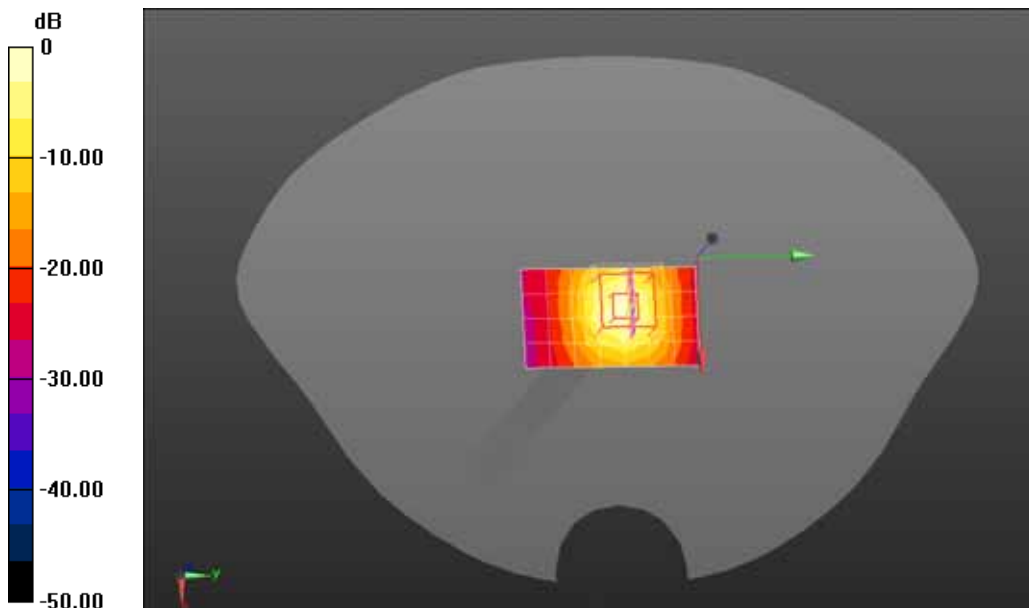

0 dB = 14.4 mW/g = 23.17 dB mW/g

## Appendix B. SAR measurement Data

Date/Time: 16-10-2013

Test Laboratory: QuieTek Lab

802.11b 2412MHz Bottom

**DUT: MaxiSys; Type: MaxiSys**

Communication System: Wi-Fi; Communication System Band: 802.11b; Duty Cycle: 1:1.0; Frequency: 2412 MHz; Medium parameters used:  $f = 2412$  MHz;  $\sigma = 1.92$  mho/m;  $\epsilon_r = 52.34$ ;  $\rho = 1000$  kg/m<sup>3</sup>; Phantom section: Flat Section

Ambient temperature (°C): 21.5, Liquid temperature (°C): 21.0

DASY5 Configuration:

- Probe: EX3DV4 - SN3710; ConvF(7.08, 7.08, 7.08); Calibrated: 27/03/2013;
- Sensor-Surface: 4mm (Mechanical Surface Detection)
- Electronics: DAE4 Sn1220; Calibrated: 24/01/2013
- Phantom: SAM1; Type: SAM; Serial: TP1561
- Measurement SW: DASY52, Version 52.8 (1); SEMCAD X Version 14.6.5 (6469)

**Configuration/802.11b 2412MHz Bottom/Area Scan (10x13x1):** Measurement grid: dx=12mm, dy=12mm

Maximum value of SAR (measured) = 0.215 mW/g

**Configuration/802.11b 2412MHz Bottom/Zoom Scan (5x5x7)/Cube 0:** Measurement grid: dx=8mm,

dy=8mm, dz=5mm, Reference Value = 6.408 V/m; Power Drift = -0.08 dB

Peak SAR (extrapolated) = 0.370 mW/g

**SAR(1 g) = 0.192 mW/g; SAR(10 g) = 0.096 mW/g** Maximum value of SAR (measured) = 0.212 mW/g

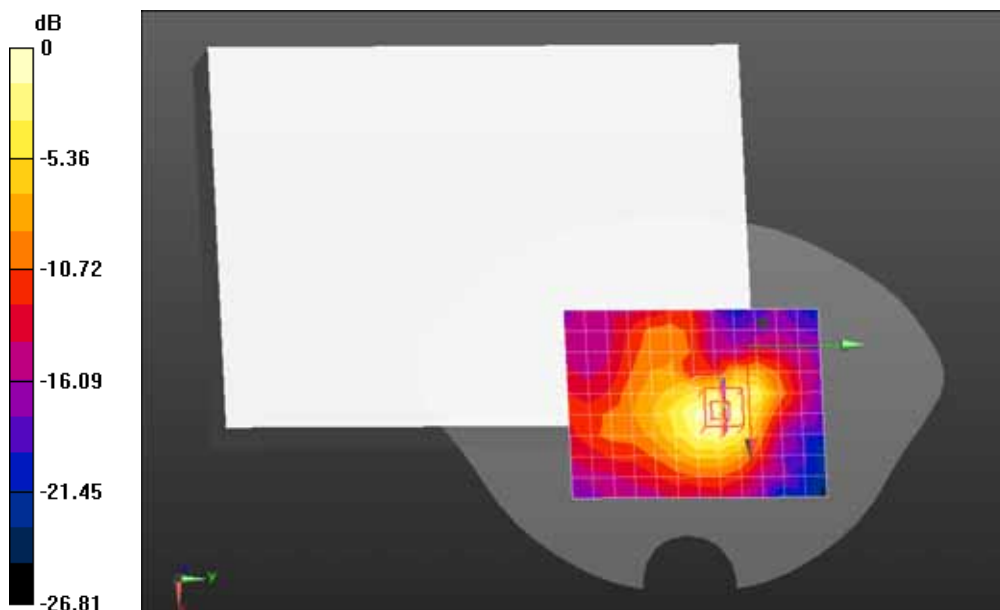

0 dB = 0.212 mW/g = -13.47 dB mW/g



Z-Axis Plot

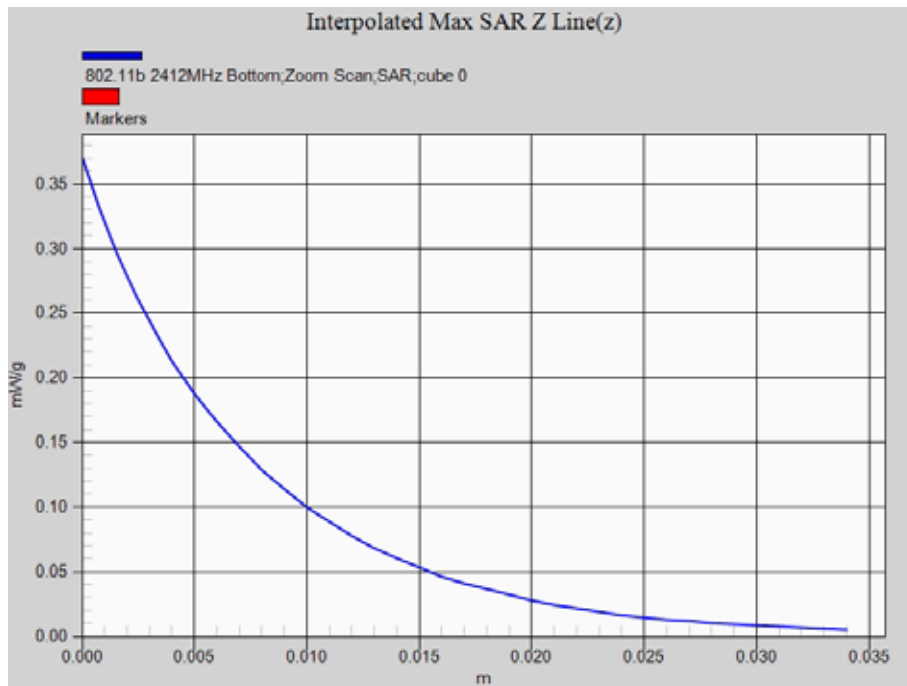

Date/Time: 16-10-2013

Test Laboratory: QuieTek Lab

802.11b 2412MHz Secondary landscape

**DUT: MaxiSys; Type: MaxiSys**

Communication System: Wi-Fi; Communication System Band: 802.11b; Duty Cycle: 1:1.0; Frequency: 2412 MHz; Medium parameters used:  $f = 2412$  MHz;  $\sigma = 1.92$  mho/m;  $\epsilon_r = 52.34$ ;  $\rho = 1000$  kg/m<sup>3</sup> ; Phantom section: Flat Section

Ambient temperature (°C): 21.5, Liquid temperature (°C): 21.0

DASY5 Configuration:

- Probe: EX3DV4 - SN3710; ConvF(7.08, 7.08, 7.08); Calibrated: 27/03/2013;
- Sensor-Surface: 4mm (Mechanical Surface Detection)
- Electronics: DAE4 Sn1220; Calibrated: 24/01/2013
- Phantom: SAM1; Type: SAM; Serial: TP1561
- Measurement SW: DASY52, Version 52.8 (1); SEMCAD X Version 14.6.5 (6469)

**Configuration/802.11b 2412MHz Secondary landscape/Area Scan (10x13x1):** Measurement grid:

dx=12mm, dy=12mm

Maximum value of SAR (measured) = 0.0664 mW/g

**Configuration/802.11b 2412MHz Secondary landscape/Zoom Scan (5x5x7)/Cube 0:** Measurement grid:

dx=8mm, dy=8mm, dz=5mm, Reference Value = 3.315 V/m; Power Drift = 0.07 dB

Peak SAR (extrapolated) = 0.119 mW/g

**SAR(1 g) = 0.065 mW/g; SAR(10 g) = 0.037 mW/g** Maximum value of SAR (measured) = 0.0707 mW/g

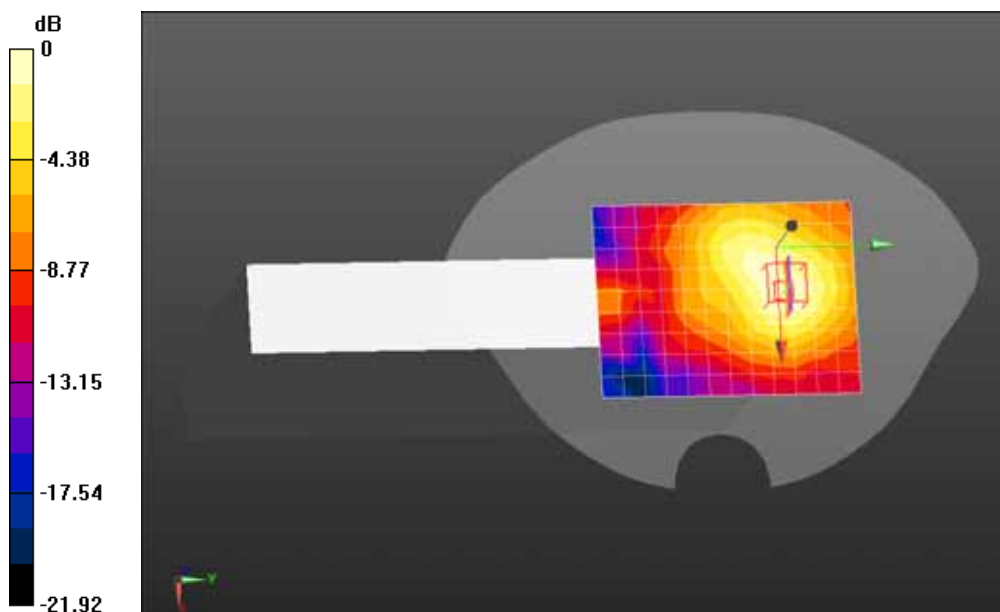

0 dB = 0.0707 mW/g = -23.01 dB mW/g

Date/Time: 16-10-2013

Test Laboratory: QuieTek Lab

802.11b 2437MHz Bottom

**DUT: MaxiSys; Type: MaxiSys**

Communication System: Wi-Fi; Communication System Band: 802.11b; Duty Cycle: 1:1.0; Frequency: 2437 MHz; Medium parameters used:  $f = 2437$  MHz;  $\sigma = 1.95$  mho/m;  $\epsilon_r = 52.31$ ;  $\rho = 1000$  kg/m<sup>3</sup> ; Phantom section: Flat Section

Ambient temperature (°C): 21.5, Liquid temperature (°C): 21.0

DASY5 Configuration:

- Probe: EX3DV4 - SN3710; ConvF(7.08, 7.08, 7.08); Calibrated: 27/03/2013;
- Sensor-Surface: 4mm (Mechanical Surface Detection)
- Electronics: DAE4 Sn1220; Calibrated: 24/01/2013
- Phantom: SAM1; Type: SAM; Serial: TP1561
- Measurement SW: DASY52, Version 52.8 (1); SEMCAD X Version 14.6.5 (6469)

**Configuration/802.11b 2437MHz Bottom/Area Scan (10x13x1):** Measurement grid: dx=12mm, dy=12mm

Maximum value of SAR (measured) = 0.188 mW/g

**Configuration/802.11b 2437MHz Bottom/Zoom Scan (5x5x7)/Cube 0:** Measurement grid: dx=8mm, dy=8mm, dz=5mm, Reference Value = 5.648 V/m; Power Drift = -0.18 dB

Peak SAR (extrapolated) = 0.330 mW/g

**SAR(1 g) = 0.171 mW/g; SAR(10 g) = 0.086 mW/g** Maximum value of SAR (measured) = 0.189 mW/g

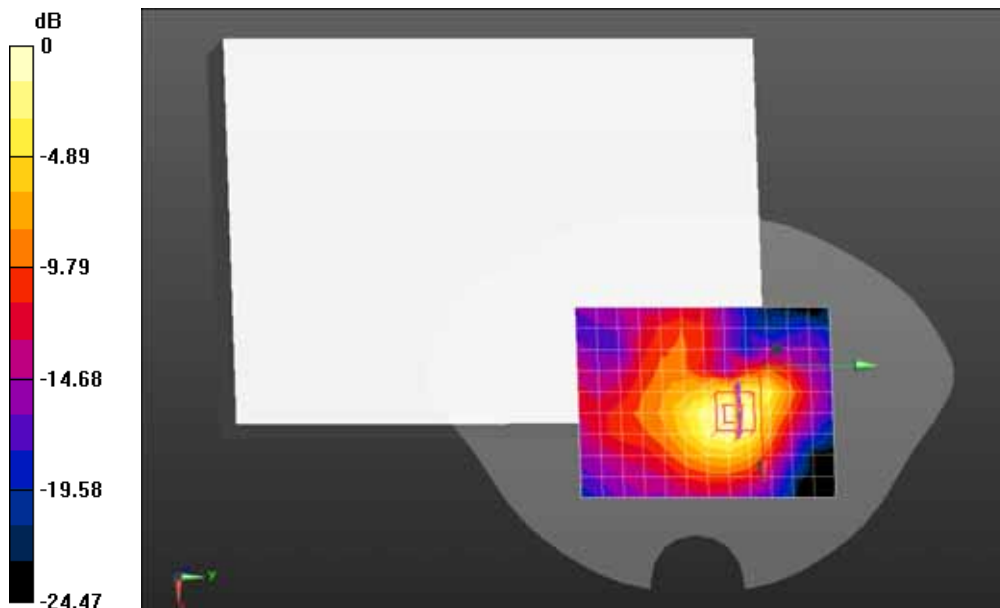

0 dB = 0.189 mW/g = -14.47 dB mW/g

Date/Time: 16-10-2013

Test Laboratory: QuieTek Lab

802.11b 2462MHz Bottom

**DUT: MaxiSys; Type: MaxiSys**

Communication System: Wi-Fi; Communication System Band: 802.11b; Duty Cycle: 1:1.0; Frequency: 2462 MHz; Medium parameters used:  $f = 2462$  MHz;  $\sigma = 1.98$  mho/m;  $\epsilon_r = 52.15$ ;  $\rho = 1000$  kg/m<sup>3</sup> ; Phantom section: Flat Section

Ambient temperature (°C): 21.5, Liquid temperature (°C): 21.0

DASY5 Configuration:

- Probe: EX3DV4 - SN3710; ConvF(7.08, 7.08, 7.08); Calibrated: 27/03/2013;
- Sensor-Surface: 4mm (Mechanical Surface Detection)
- Electronics: DAE4 Sn1220; Calibrated: 24/01/2013
- Phantom: SAM1; Type: SAM; Serial: TP1561
- Measurement SW: DASY52, Version 52.8 (1); SEMCAD X Version 14.6.5 (6469)

**Configuration/802.11b 2462MHz Bottom/Area Scan (10x13x1):** Measurement grid: dx=12mm, dy=12mm

Maximum value of SAR (measured) = 0.155 mW/g

**Configuration/802.11b 2462MHz Bottom/Zoom Scan (5x5x7)/Cube 0:** Measurement grid: dx=8mm, dy=8mm, dz=5mm, Reference Value = 5.601 V/m; Power Drift = -0.02 dB

Peak SAR (extrapolated) = 0.309 mW/g

**SAR(1 g) = 0.157 mW/g; SAR(10 g) = 0.078 mW/g** Maximum value of SAR (measured) = 0.174 mW/g

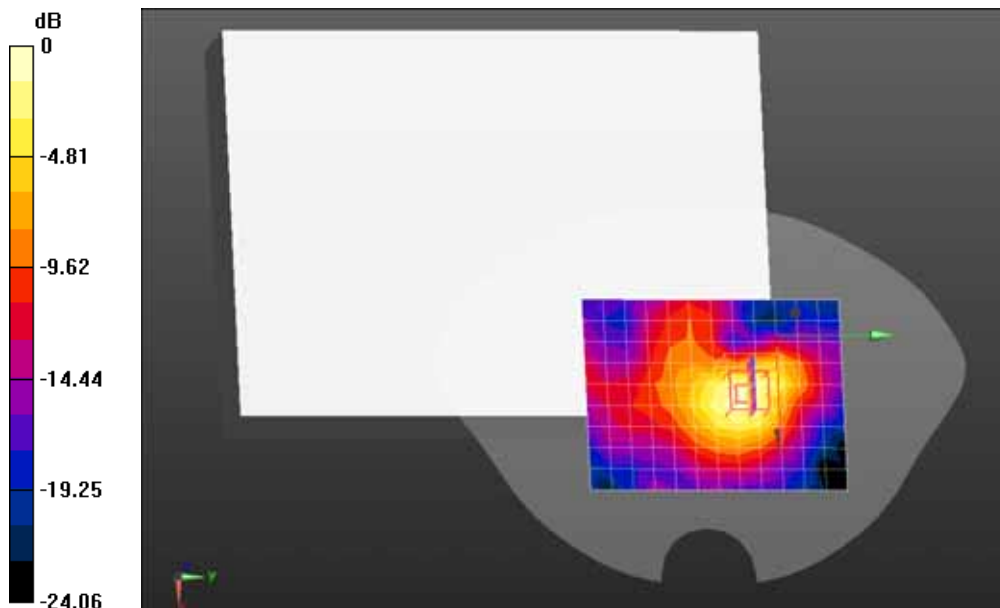

0 dB = 0.174 mW/g = -15.19 dB mW/g

Date/Time: 16-10-2013

Test Laboratory: QuieTek Lab  
 802.11a 5180MHz Body-Bottom

**DUT: MaxiSys; Type: MaxiSys**

Communication System: CW; Communication System Band: 5GHz(5000.0-6000.0MHz); Duty Cycle: 1:1.0;  
 Frequency: 5180 MHz; Medium parameters used:  $f = 5180 \text{ MHz}$ ;  $\sigma = 5.12 \text{ mho/m}$ ;  $\epsilon_r = 49.02$ ;  $\rho = 1000 \text{ kg/m}^3$ ; Phantom section: Flat Section

Ambient temperature (°C): 21.5, Liquid temperature (°C): 21.0

DASY5 Configuration:

- Probe: EX3DV4 - SN3710; ConvF(4.32, 4.32, 4.32); Calibrated: 27/03/2013;
- Sensor-Surface: 2mm (Mechanical Surface Detection)
- Electronics: DAE4 Sn1220; Calibrated: 24/01/2013
- Phantom: SAM2; Type: SAM; Serial: TP1562
- Measurement SW: DASY52, Version 52.8 (1); SEMCAD X Version 14.6.5 (6469)

**Configuration/802.11a 5180MHz Body-Bottom/Area Scan (11x11x1):** Measurement grid: dx=10mm, dy=10mm

Maximum value of SAR (measured) = 0.483 mW/g

**Configuration/802.11a 5180MHz Body-Bottom/Zoom Scan (8x8x6)/Cube 0:** Measurement grid: dx=4mm, dy=4mm, dz=2mm, Reference Value = 5.152 V/m; Power Drift = 0.10 dB

Peak SAR (extrapolated) = 0.913 mW/g

**SAR(1 g) = 0.262 mW/g; SAR(10 g) = 0.104 mW/g** Maximum value of SAR (measured) = 0.466 mW/g

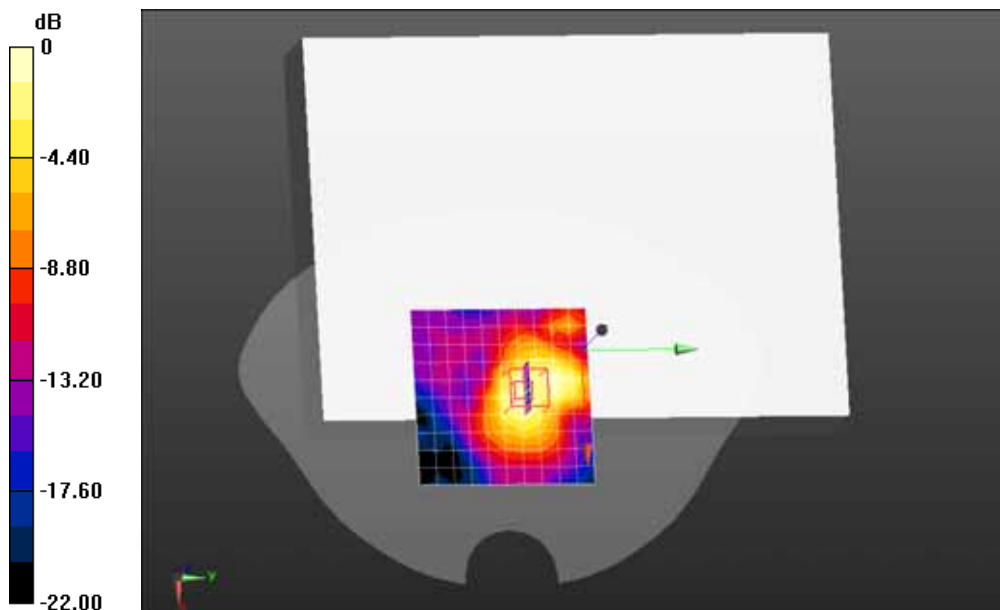

0 dB = 0.466 mW/g = -6.63 dB mW/g

Date/Time: 16-10-2013

Test Laboratory: QuieTek Lab

802.11a 5180MHz Body-Secondary Landscape

**DUT: MaxiSys; Type: MaxiSys**

Communication System: CW; Communication System Band: 5GHz(5000.0-6000.0MHz); Duty Cycle: 1:1.0; Frequency: 5180 MHz; Medium parameters used:  $f = 5180 \text{ MHz}$ ;  $\sigma = 5.12 \text{ mho/m}$ ;  $\epsilon_r = 49.02$ ;  $\rho = 1000 \text{ kg/m}^3$ ; Phantom section: Flat Section

Ambient temperature (°C): 21.5, Liquid temperature (°C): 21.0

DASY5 Configuration:

- Probe: EX3DV4 - SN3710; ConvF(4.32, 4.32, 4.32); Calibrated: 27/03/2013;
- Sensor-Surface: 2mm (Mechanical Surface Detection)
- Electronics: DAE4 Sn1220; Calibrated: 24/01/2013
- Phantom: SAM2; Type: SAM; Serial: TP1562
- Measurement SW: DASY52, Version 52.8 (1); SEMCAD X Version 14.6.5 (6469)

**Configuration/802.11a 5180MHz Body-Secondary landscape/Area Scan (11x11x1):** Measurement grid:

$dx=10\text{mm}$ ,  $dy=10\text{mm}$

Maximum value of SAR (measured) = 0.182 mW/g

**Configuration/802.11a 5180MHz Body-Secondary landscape/Zoom Scan (9x9x6)/Cube 0:**

Measurement grid:  $dx=4\text{mm}$ ,  $dy=4\text{mm}$ ,  $dz=2\text{mm}$ , Reference Value = 0.952 V/m; Power Drift = 0.14 dB

Peak SAR (extrapolated) = 0.362 mW/g

**SAR(1 g) = 0.104 mW/g; SAR(10 g) = 0.043 mW/g** Maximum value of SAR (measured) = 0.186 mW/g

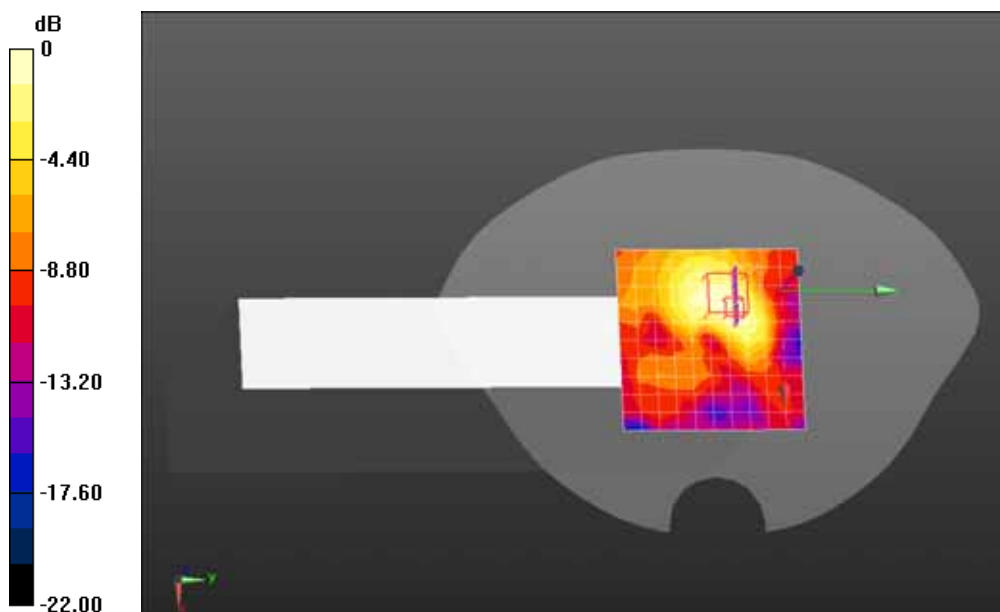

0 dB = 0.186 mW/g = -14.61 dB mW/g

Date/Time: 16-10-2013

Test Laboratory: QuieTek Lab  
 802.11a 5220MHz Body-Bottom

**DUT: MaxiSys; Type: MaxiSys**

Communication System: CW; Communication System Band: 5GHz(5000.0-6000.0MHz); Duty Cycle: 1:1.0;  
 Frequency: 5220 MHz; Medium parameters used:  $f = 5220 \text{ MHz}$ ;  $\sigma = 5.18 \text{ mho/m}$ ;  $\epsilon_r = 48.89$ ;  $\rho = 1000 \text{ kg/m}^3$ ; Phantom section: Flat Section

Ambient temperature (°C): 21.5, Liquid temperature (°C): 21.0

DASY5 Configuration:

- Probe: EX3DV4 - SN3710; ConvF(4.32, 4.32, 4.32); Calibrated: 27/03/2013;
- Sensor-Surface: 2mm (Mechanical Surface Detection)
- Electronics: DAE4 Sn1220; Calibrated: 24/01/2013
- Phantom: SAM2; Type: SAM; Serial: TP1562
- Measurement SW: DASY52, Version 52.8 (1); SEMCAD X Version 14.6.5 (6469)

**Configuration/802.11a 5220MHz Body-Bottom/Area Scan (11x11x1):** Measurement grid: dx=10mm, dy=10mm

Maximum value of SAR (measured) = 0.521 mW/g

**Configuration/802.11a 5220MHz Body-Bottom/Zoom Scan (9x9x6)/Cube 0:** Measurement grid:

dx=4mm, dy=4mm, dz=2mm, Reference Value = 5.428 V/m; Power Drift = -0.06 dB

Peak SAR (extrapolated) = 1.019 mW/g

**SAR(1 g) = 0.296 mW/g; SAR(10 g) = 0.118 mW/g** Maximum value of SAR (measured) = 0.522 mW/g

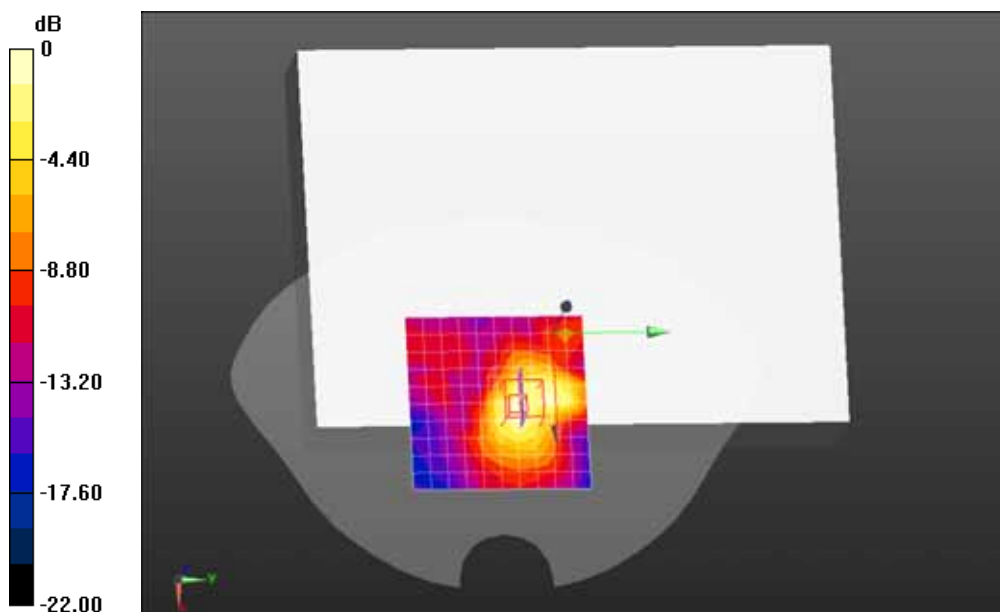

0 dB = 0.522 mW/g = -5.65 dB mW/g

Z-Axis Plot

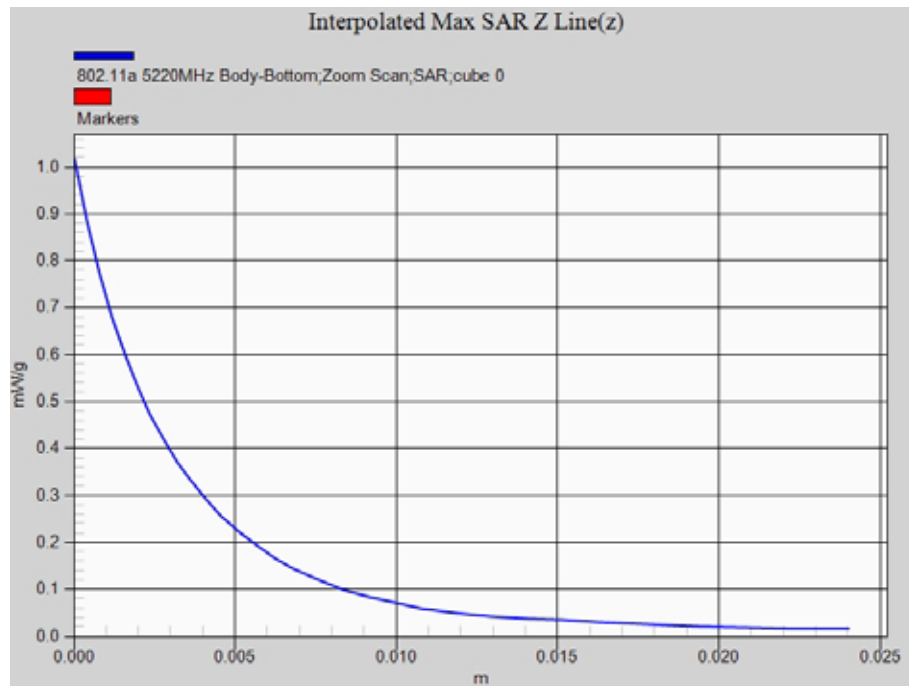



Date/Time: 16-10-2013

Test Laboratory: QuieTek Lab  
 802.11a 5765MHz Body-Bottom

**DUT: MaxiSys; Type: MaxiSys**

Communication System: CW; Communication System Band: 5GHz(5000.0-6000.0MHz); Duty Cycle: 1:1.0;  
 Frequency: 5765 MHz; Medium parameters used:  $f = 5765$  MHz;  $\sigma = 5.86$  mho/m;  $\epsilon_r = 47.57$ ;  $\rho = 1000$  kg/m<sup>3</sup> ; Phantom section: Flat Section

Ambient temperature (°C): 21.5, Liquid temperature (°C): 21.0

DASY5 Configuration:

- Probe: EX3DV4 - SN3710; ConvF(4.05, 4.05, 4.05); Calibrated: 27/03/2013;
- Sensor-Surface: 2mm (Mechanical Surface Detection)
- Electronics: DAE4 Sn1220; Calibrated: 24/01/2013
- Phantom: SAM2; Type: SAM; Serial: TP1562
- Measurement SW: DASY52, Version 52.8 (1); SEMCAD X Version 14.6.5 (6469)

**Configuration/802.11a 5765MHz Body-Bottom/Area Scan (11x11x1):** Measurement grid: dx=10mm, dy=10mm

Maximum value of SAR (measured) = 0.276 mW/g

**Configuration/802.11a 5765MHz Body-Bottom/Zoom Scan (8x8x6)/Cube 0:** Measurement grid: dx=4mm, dy=4mm, dz=2mm, Reference Value = 3.659 V/m; Power Drift = -0.01 dB

Peak SAR (extrapolated) = 0.602 mW/g

**SAR(1 g) = 0.164 mW/g; SAR(10 g) = 0.067 mW/g** Maximum value of SAR (measured) = 0.296 mW/g

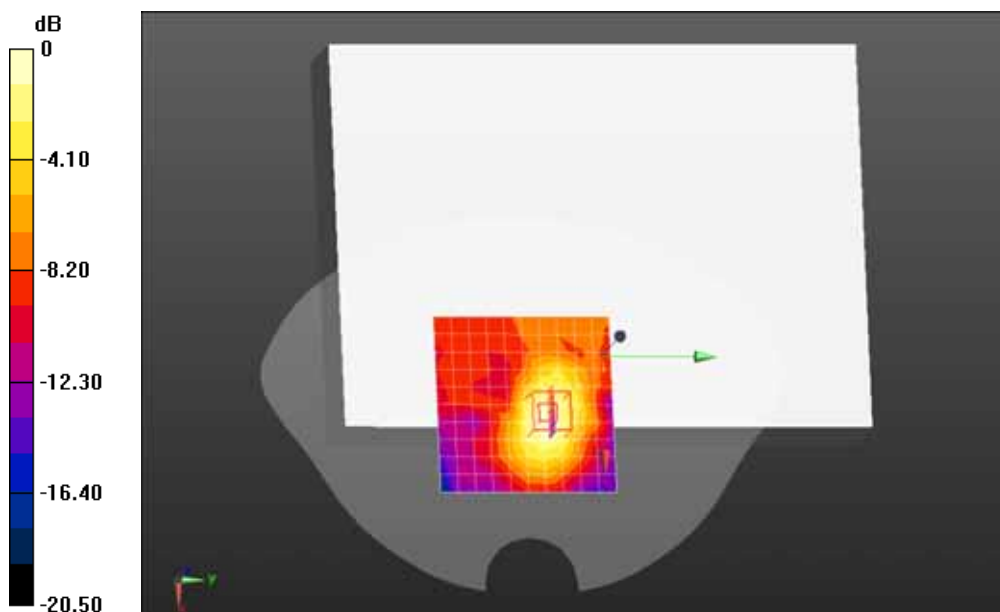

0 dB = 0.296 mW/g = -10.57 dB mW/g

Date/Time: 16-10-2013

Test Laboratory: QuieTek Lab  
 802.11a 5785MHz Body-Bottom

**DUT: MaxiSys; Type: MaxiSys**

Communication System: CW; Communication System Band: 5GHz(5000.0-6000.0MHz); Duty Cycle: 1:1.0;  
 Frequency: 5785 MHz; Medium parameters used:  $f = 5785 \text{ MHz}$ ;  $\sigma = 5.87 \text{ mho/m}$ ;  $\epsilon_r = 47.55$ ;  $\rho = 1000 \text{ kg/m}^3$ ; Phantom section: Flat Section

Ambient temperature (°C): 21.5, Liquid temperature (°C): 21.0

DASY5 Configuration:

- Probe: EX3DV4 - SN3710; ConvF(4.05, 4.05, 4.05); Calibrated: 27/03/2013;
- Sensor-Surface: 2mm (Mechanical Surface Detection)
- Electronics: DAE4 Sn1220; Calibrated: 24/01/2013
- Phantom: SAM2; Type: SAM; Serial: TP1562
- Measurement SW: DASY52, Version 52.8 (1); SEMCAD X Version 14.6.5 (6469)

**Configuration/802.11a 5785MHz Body-Bottom/Area Scan (11x11x1):** Measurement grid: dx=10mm, dy=10mm

Maximum value of SAR (measured) = 0.276 mW/g

**Configuration/802.11a 5785MHz Body-Bottom/Zoom Scan (8x8x6)/Cube 0:** Measurement grid: dx=4mm, dy=4mm, dz=2mm, Reference Value = 3.332 V/m; Power Drift = -0.03 dB

Peak SAR (extrapolated) = 0.498 mW/g

**SAR(1 g) = 0.145 mW/g; SAR(10 g) = 0.068 mW/g** Maximum value of SAR (measured) = 0.277 mW/g

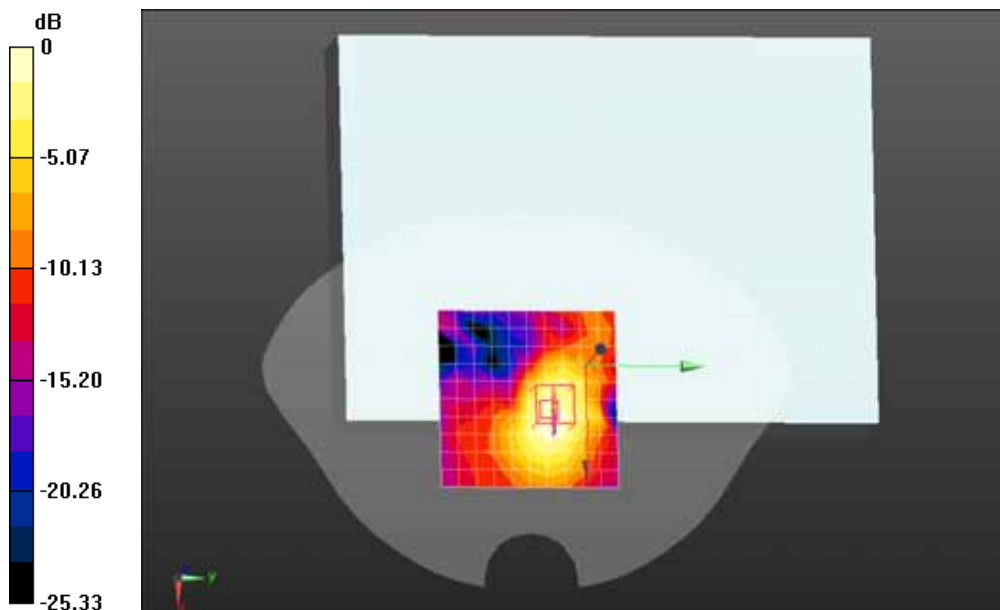

0 dB = 0.277 mW/g = -11.15 dB mW/g

Date/Time: 16-10-2013

Test Laboratory: QuieTek Lab  
 802.11a 5805MHz Body-Bottom

**DUT: MaxiSys; Type: MaxiSys**

Communication System: CW; Communication System Band: 5GHz(5000.0-6000.0MHz); Duty Cycle: 1:1.0;  
 Frequency: 5805 MHz; Medium parameters used:  $f = 5805 \text{ MHz}$ ;  $\sigma = 5.87 \text{ mho/m}$ ;  $\epsilon_r = 47.52$ ;  $\rho = 1000 \text{ kg/m}^3$ ; Phantom section: Flat Section

Ambient temperature (°C): 21.5, Liquid temperature (°C): 21.0

DASY5 Configuration:

- Probe: EX3DV4 - SN3710; ConvF(4.05, 4.05, 4.05); Calibrated: 27/03/2013;
- Sensor-Surface: 2mm (Mechanical Surface Detection)
- Electronics: DAE4 Sn1220; Calibrated: 24/01/2013
- Phantom: SAM2; Type: SAM; Serial: TP1562
- Measurement SW: DASY52, Version 52.8 (1); SEMCAD X Version 14.6.5 (6469)

**Configuration/802.11a 5805MHz Body-Bottom/Area Scan (11x11x1):** Measurement grid: dx=10mm, dy=10mm

Maximum value of SAR (measured) = 0.279 mW/g

**Configuration/802.11a 5805MHz Body-Bottom/Zoom Scan (8x8x6)/Cube 0:** Measurement grid: dx=4mm, dy=4mm, dz=2mm, Reference Value = 3.702 V/m; Power Drift = -0.03 dB

Peak SAR (extrapolated) = 0.695 mW/g

**SAR(1 g) = 0.165 mW/g; SAR(10 g) = 0.071 mW/g** Maximum value of SAR (measured) = 0.295 mW/g

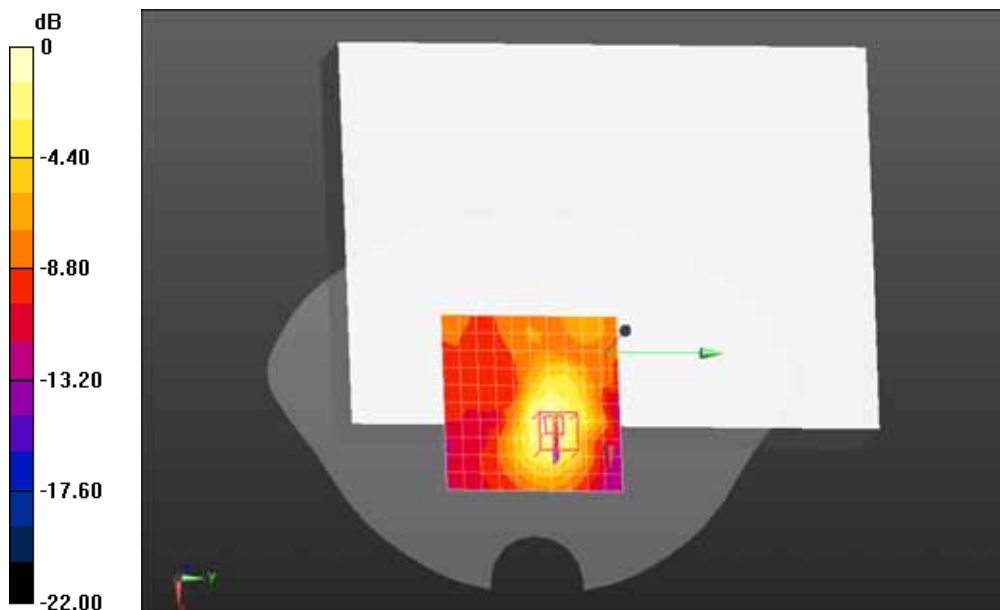

0 dB = 0.295 mW/g = -10.60 dB mW/g

Date/Time: 16-10-2013

Test Laboratory: QuieTek Lab

802.11n(20) 5180MHz Body-Bottom

**DUT: MaxiSys; Type: MaxiSys**

Communication System: CW; Communication System Band: 5GHz(5000.0-6000.0MHz); Duty Cycle: 1:1.0; Frequency: 5180 MHz; Medium parameters used:  $f = 5180$  MHz;  $\sigma = 5.12$  mho/m;  $\epsilon_r = 49.02$ ;  $\rho = 1000$  kg/m<sup>3</sup> ; Phantom section: Flat Section

Ambient temperature (°C): 21.5, Liquid temperature (°C): 21.0

DASY5 Configuration:

- Probe: EX3DV4 - SN3710; ConvF(4.32, 4.32, 4.32); Calibrated: 27/03/2013;
- Sensor-Surface: 2mm (Mechanical Surface Detection)
- Electronics: DAE4 Sn1220; Calibrated: 24/01/2013
- Phantom: SAM2; Type: SAM; Serial: TP1562
- Measurement SW: DASY52, Version 52.8 (1); SEMCAD X Version 14.6.5 (6469)

**Configuration/802.11n(20) 5180MHz Body-Bottom/Area Scan (11x11x1):** Measurement grid: dx=10mm, dy=10mm

Maximum value of SAR (measured) = 0.454 mW/g

**Configuration/802.11n(20) 5180MHz Body-Bottom/Zoom Scan (8x8x6)/Cube 0:** Measurement grid: dx=4mm, dy=4mm, dz=2mm, Reference Value = 3.423 V/m; Power Drift = -0.07 dB

Peak SAR (extrapolated) = 0.850 mW/g

**SAR(1 g) = 0.244 mW/g; SAR(10 g) = 0.093 mW/g** Maximum value of SAR (measured) = 0.457 mW/g

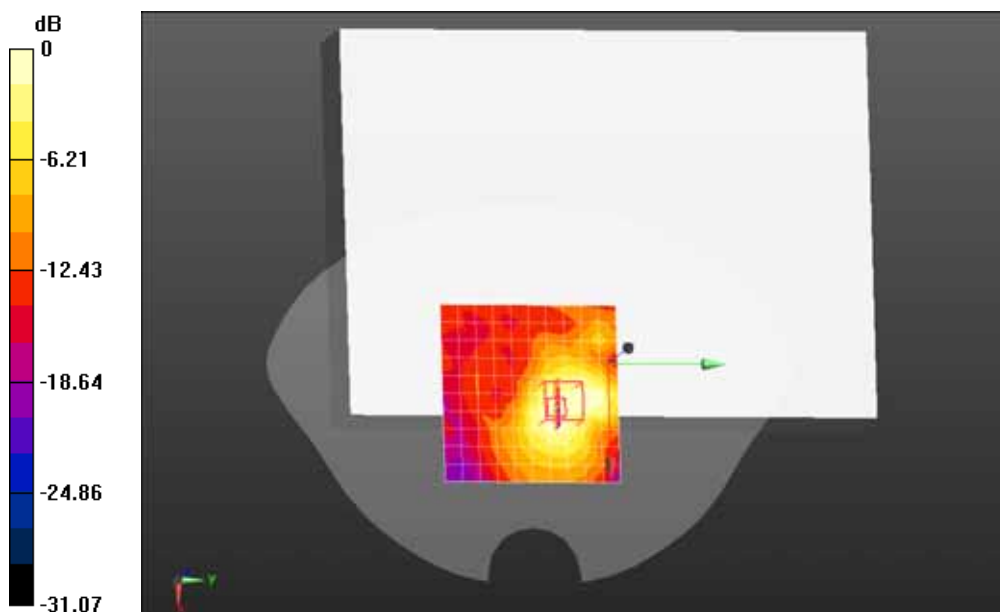

0 dB = 0.457 mW/g = -6.80 dB mW/g

Date/Time: 16-10-2013

Test Laboratory: QuieTek Lab

802.11n(20) 5180MHz Body-Secondary Landscape

**DUT: MaxiSys; Type: MY908**

Communication System: CW; Communication System Band: 5GHz(5000.0-6000.0MHz); Duty Cycle: 1:1.0; Frequency: 5180 MHz; Medium parameters used:  $f = 5180 \text{ MHz}$ ;  $\sigma = 5.12 \text{ mho/m}$ ;  $\epsilon_r = 49.02$ ;  $\rho = 1000 \text{ kg/m}^3$ ; Phantom section: Flat Section

Ambient temperature (°C): 21.5, Liquid temperature (°C): 21.0

DASY5 Configuration:

- Probe: EX3DV4 - SN3710; ConvF(4.32, 4.32, 4.32); Calibrated: 27/03/2013;
- Sensor-Surface: 2mm (Mechanical Surface Detection)
- Electronics: DAE4 Sn1220; Calibrated: 24/01/2013
- Phantom: SAM2; Type: SAM; Serial: TP1562
- Measurement SW: DASY52, Version 52.8 (1); SEMCAD X Version 14.6.5 (6469)

**Configuration/802.11n(20) 5180MHz Body-Secondary landscape/Area Scan (11x11x1):** Measurement grid: dx=10mm, dy=10mm

Maximum value of SAR (measured) = 0.229 mW/g

**Configuration/802.11n(20) 5180MHz Body-Secondary landscape/Zoom Scan (9x9x6)/Cube 0:**

Measurement grid: dx=4mm, dy=4mm, dz=2mm, Reference Value = 3.900 V/m; Power Drift = 0.18 dB

Peak SAR (extrapolated) = 0.454 mW/g

**SAR(1 g) = 0.151 mW/g; SAR(10 g) = 0.090 mW/g** Maximum value of SAR (measured) = 0.236 mW/g

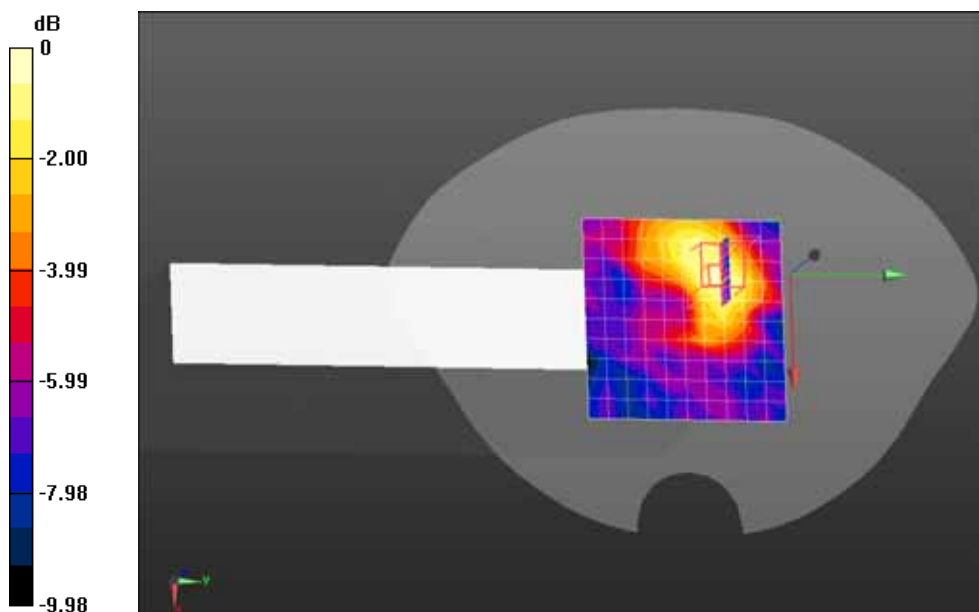

0 dB = 0.236 mW/g = -12.54 dB mW/g

Date/Time: 16-10-2013

Test Laboratory: QuieTek Lab

802.11n(20) 5765MHz Body-Bottom

**DUT: MaxiSys; Type: MaxiSys**

Communication System: CW; Communication System Band: 5GHz(5000.0-6000.0MHz); Duty Cycle: 1:1.0; Frequency: 5765 MHz; Medium parameters used:  $f = 5765$  MHz;  $\sigma = 5.86$  mho/m;  $\epsilon_r = 47.57$ ;  $\rho = 1000$  kg/m<sup>3</sup> ; Phantom section: Flat Section

Ambient temperature (°C): 21.5, Liquid temperature (°C): 21.0

DASY5 Configuration:

- Probe: EX3DV4 - SN3710; ConvF(4.05, 4.05, 4.05); Calibrated: 27/03/2013;
- Sensor-Surface: 2mm (Mechanical Surface Detection)
- Electronics: DAE4 Sn1220; Calibrated: 24/01/2013
- Phantom: SAM2; Type: SAM; Serial: TP1562
- Measurement SW: DASY52, Version 52.8 (1); SEMCAD X Version 14.6.5 (6469)

**Configuration/802.11n(20) 5765MHz Body-Bottom/Area Scan (11x11x1):** Measurement grid: dx=10mm, dy=10mm

Maximum value of SAR (measured) = 0.287 mW/g

**Configuration/802.11n(20) 5765MHz Body-Bottom/Zoom Scan (8x8x6)/Cube 0:** Measurement grid: dx=4mm, dy=4mm, dz=2mm, Reference Value = 3.977 V/m; Power Drift = 0.18 dB

Peak SAR (extrapolated) = 0.677 mW/g

**SAR(1 g) = 0.169 mW/g; SAR(10 g) = 0.075 mW/g** Maximum value of SAR (measured) = 0.292 mW/g

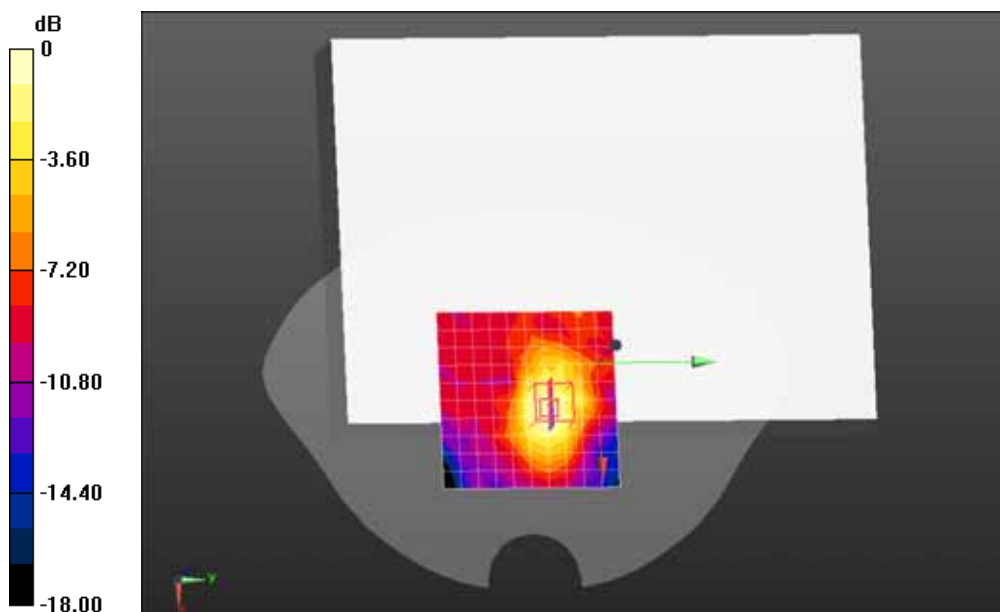

0 dB = 0.292 mW/g = -10.69 dB mW/g

Date/Time: 16-10-2013

Test Laboratory: QuieTek Lab

802.11n(40) 5180MHz Body-Bottom

**DUT: MaxiSys; Type: MaxiSys**

Communication System: CW; Communication System Band: 5GHz(5000.0-6000.0MHz); Duty Cycle: 1:1.0; Frequency: 5180 MHz; Medium parameters used:  $f = 5180$  MHz;  $\sigma = 5.12$  mho/m;  $\epsilon_r = 49.02$ ;  $\rho = 1000$  kg/m<sup>3</sup> ; Phantom section: Flat Section

Ambient temperature (°C): 21.5, Liquid temperature (°C): 21.0

DASY5 Configuration:

- Probe: EX3DV4 - SN3710; ConvF(4.32, 4.32, 4.32); Calibrated: 27/03/2013;
- Sensor-Surface: 2mm (Mechanical Surface Detection)
- Electronics: DAE4 Sn1220; Calibrated: 24/01/2013
- Phantom: SAM2; Type: SAM; Serial: TP1562
- Measurement SW: DASY52, Version 52.8 (1); SEMCAD X Version 14.6.5 (6469)

**Configuration/802.11n(40) 5180MHz Body-Bottom/Area Scan (11x11x1):** Measurement grid: dx=10mm, dy=10mm

Maximum value of SAR (measured) = 0.476 mW/g

**Configuration/802.11n(40) 5180MHz Body-Bottom/Zoom Scan (8x8x6)/Cube 0:** Measurement grid: dx=4mm, dy=4mm, dz=2mm, Reference Value = 5.255 V/m; Power Drift = 0.11 dB

Peak SAR (extrapolated) = 0.889 mW/g

**SAR(1 g) = 0.253 mW/g; SAR(10 g) = 0.096 mW/g** Maximum value of SAR (measured) = 0.476 mW/g

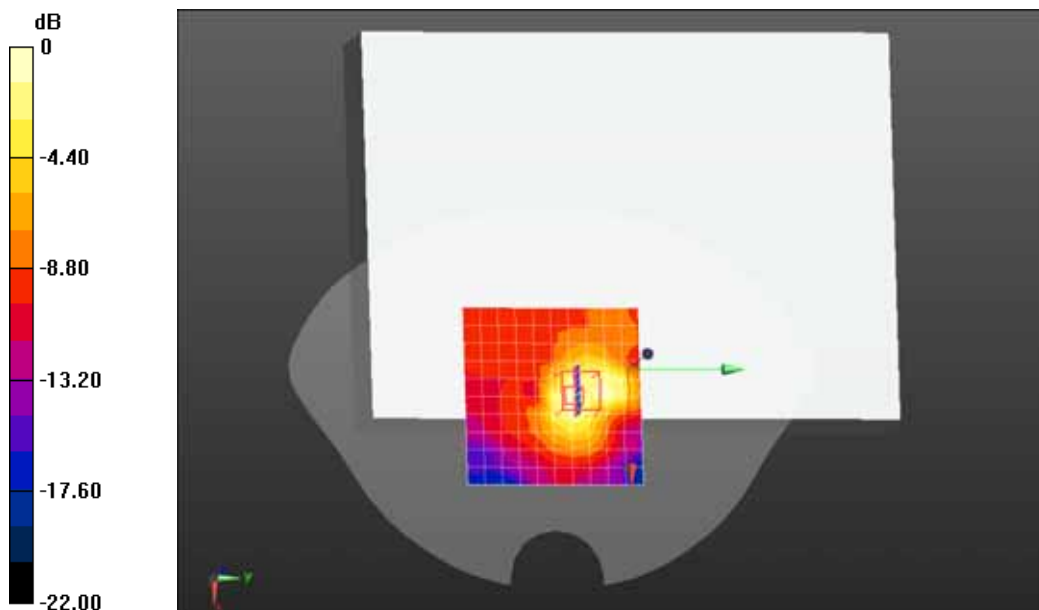

0 dB = 0.476 mW/g = -6.45 dB mW/g

Date/Time: 16-10-2013

Test Laboratory: QuieTek Lab

802.11n(40) 5180MHz Body-Secondary Landscape

**DUT: MaxiSys; Type: MY908**

Communication System: CW; Communication System Band: 5GHz(5000.0-6000.0MHz); Duty Cycle: 1:1.0; Frequency: 5180 MHz; Medium parameters used:  $f = 5180 \text{ MHz}$ ;  $\sigma = 5.12 \text{ mho/m}$ ;  $\epsilon_r = 49.02$ ;  $\rho = 1000 \text{ kg/m}^3$ ; Phantom section: Flat Section

Ambient temperature (°C): 21.5, Liquid temperature (°C): 21.0

DASY5 Configuration:

- Probe: EX3DV4 - SN3710; ConvF(4.32, 4.32, 4.32); Calibrated: 27/03/2013;
- Sensor-Surface: 2mm (Mechanical Surface Detection)
- Electronics: DAE4 Sn1220; Calibrated: 24/01/2013
- Phantom: SAM2; Type: SAM; Serial: TP1562
- Measurement SW: DASY52, Version 52.8 (1); SEMCAD X Version 14.6.5 (6469)

**Configuration/802.11n(40) 5180MHz Body-Secondary landscape/Area Scan (11x11x1):** Measurement grid: dx=10mm, dy=10mm

Maximum value of SAR (measured) = 0.254 mW/g

**Configuration/802.11n(40) 5180MHz Body-Secondary landscape/Zoom Scan (9x9x6)/Cube 0:**

Measurement grid: dx=4mm, dy=4mm, dz=2mm, Reference Value = 3.935 V/m; Power Drift = -0.17 dB

Peak SAR (extrapolated) = 0.502 mW/g

**SAR(1 g) = 0.174 mW/g; SAR(10 g) = 0.100 mW/g**

Maximum value of SAR (measured) = 0.277 mW/g

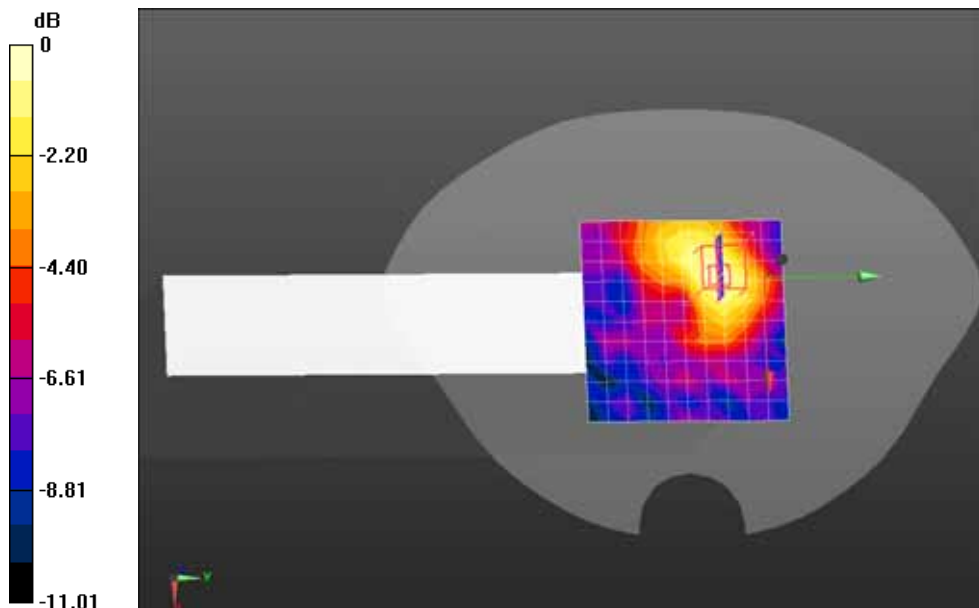

0 dB = 0.277 mW/g = -11.15 dB mW/g



Date/Time: 16-10-2013

Test Laboratory: QuieTek Lab

802.11n(40) 5745MHz Body-Bottom

**DUT: MaxiSys; Type: MaxiSys**

Communication System: CW; Communication System Band: 5GHz(5000.0-6000.0MHz); Duty Cycle: 1:1.0; Frequency: 5745 MHz; Medium parameters used:  $f = 5745 \text{ MHz}$ ;  $\sigma = 5.95 \text{ mho/m}$ ;  $\epsilon_r = 47.44$ ;  $\rho = 1000 \text{ kg/m}^3$ ; Phantom section: Flat Section

Ambient temperature (°C): 21.5, Liquid temperature (°C): 21.0

DASY5 Configuration:

- Probe: EX3DV4 - SN3710; ConvF(4.05, 4.05, 4.05); Calibrated: 27/03/2013;
- Sensor-Surface: 2mm (Mechanical Surface Detection)
- Electronics: DAE4 Sn1220; Calibrated: 24/01/2013
- Phantom: SAM2; Type: SAM; Serial: TP1562
- Measurement SW: DASY52, Version 52.8 (1); SEMCAD X Version 14.6.5 (6469)

**Configuration/802.11n(40) 5745MHz Body-Bottom/Area Scan (11x11x1):** Measurement grid: dx=10mm, dy=10mm

Maximum value of SAR (measured) = 0.278 mW/g

**Configuration/802.11n(40) 5745MHz Body-Bottom/Zoom Scan (8x8x6)/Cube 0:** Measurement grid: dx=4mm, dy=4mm, dz=2mm, Reference Value = 3.498 V/m; Power Drift = -0.14 dB

Peak SAR (extrapolated) = 0.643 mW/g

**SAR(1 g) = 0.164 mW/g; SAR(10 g) = 0.062 mW/g** Maximum value of SAR (measured) = 0.299 mW/g

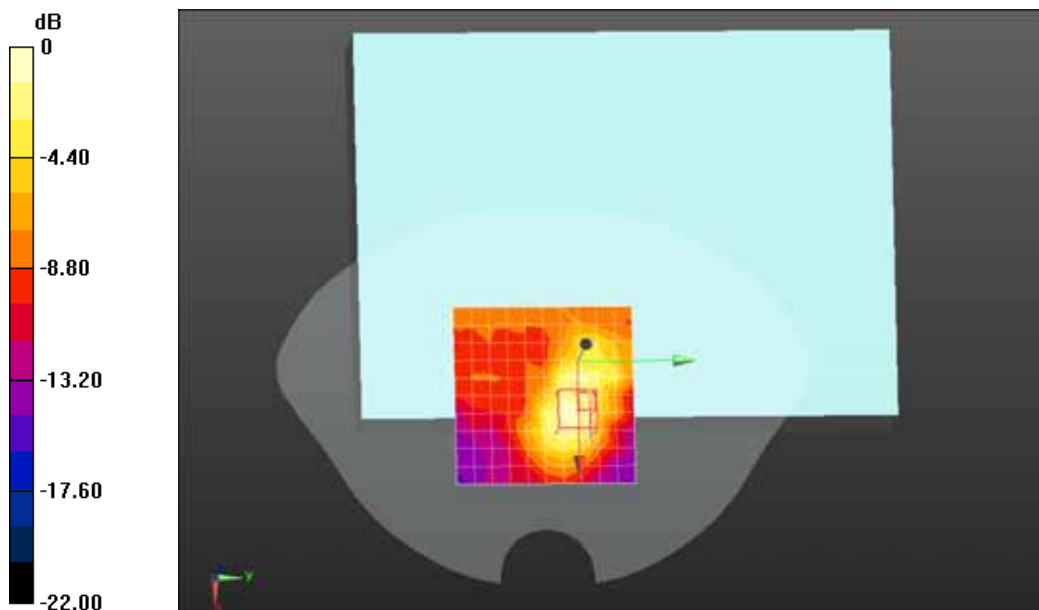

0 dB = 0.299 mW/g = -10.49 dB mW/g

Date/Time: 16-10-2013

Test Laboratory: QuieTek Lab

Bluetooth 2480MHz Bottom

**DUT: MaxiSys; Type: MaxiSys**

Communication System: Bluetooth; Communication System Band: ISM Band; Duty Cycle: 1:1.0; Frequency: 2480 MHz; Medium parameters used:  $f = 2480$  MHz;  $\sigma = 2$  mho/m;  $\epsilon_r = 52.02$ ;  $\rho = 1000$  kg/m<sup>3</sup>; Phantom section: Flat Section

Ambient temperature (°C): 21.5, Liquid temperature (°C): 21.0

DASY5 Configuration:

- Probe: EX3DV4 - SN3710; ConvF(7.08, 7.08, 7.08); Calibrated: 27/03/2013;
- Sensor-Surface: 4mm (Mechanical Surface Detection)
- Electronics: DAE4 Sn1220; Calibrated: 24/01/2013
- Phantom: SAM1; Type: SAM; Serial: TP1561
- Measurement SW: DASY52, Version 52.8 (1); SEMCAD X Version 14.6.5 (6469)

**Configuration/Bluetooth 2480MHz Bottom/Area Scan (10x10x1):** Measurement grid: dx=12mm, dy=12mm

Maximum value of SAR (measured) = 0.0160 mW/g

**Configuration/Bluetooth 2480MHz Bottom/Zoom Scan (6x6x7)/Cube 0:** Measurement grid: dx=8mm, dy=8mm, dz=5mm, Reference Value = 2.494 V/m; Power Drift = 0.05 dB

Peak SAR (extrapolated) = 0.024 mW/g

**SAR(1 g) = 0.016 mW/g; SAR(10 g) = 0.00892 mW/g** Maximum value of SAR (measured) = 0.0182 mW/g

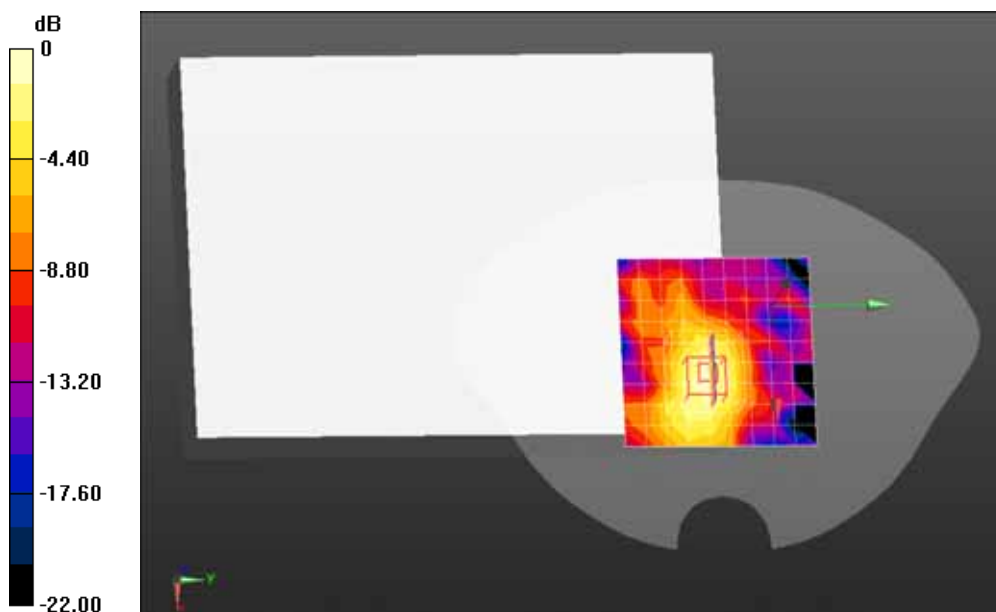

0 dB = 0.0182 mW/g = -34.80 dB mW/g

Date/Time: 16-10-2013

Test Laboratory: QuieTek Lab

Bluetooth 2480MHz Primary portrait

**DUT: MaxiSys; Type: MaxiSys**

Communication System: Bluetooth; Communication System Band: ISM Band; Duty Cycle: 1:1.0; Frequency: 2480 MHz; Medium parameters used:  $f = 2480$  MHz;  $\sigma = 2$  mho/m;  $\epsilon_r = 52.02$ ;  $\rho = 1000$  kg/m<sup>3</sup>; Phantom section: Flat Section

Ambient temperature (°C): 21.5, Liquid temperature (°C): 21.0

DASY5 Configuration:

- Probe: EX3DV4 - SN3710; ConvF(7.08, 7.08, 7.08); Calibrated: 27/03/2013;
- Sensor-Surface: 4mm (Mechanical Surface Detection)
- Electronics: DAE4 Sn1220; Calibrated: 24/01/2013
- Phantom: SAM1; Type: SAM; Serial: TP1561
- Measurement SW: DASY52, Version 52.8 (1); SEMCAD X Version 14.6.5 (6469)

**Configuration/Bluetooth 2480MHz Primary portrait/Area Scan (10x10x1):** Measurement grid: dx=12mm, dy=12mm

Maximum value of SAR (measured) = 0.0176 mW/g

**Configuration/Bluetooth 2480MHz Primary portrait/Zoom Scan (5x5x7)/Cube 0:** Measurement grid: dx=8mm, dy=8mm, dz=5mm, Reference Value = 1.817 V/m; Power Drift = 0.09 dB

Peak SAR (extrapolated) = 0.047 mW/g

**SAR(1 g) = 0.019 mW/g; SAR(10 g) = 0.00957 mW/g** Maximum value of SAR (measured) = 0.0206 mW/g

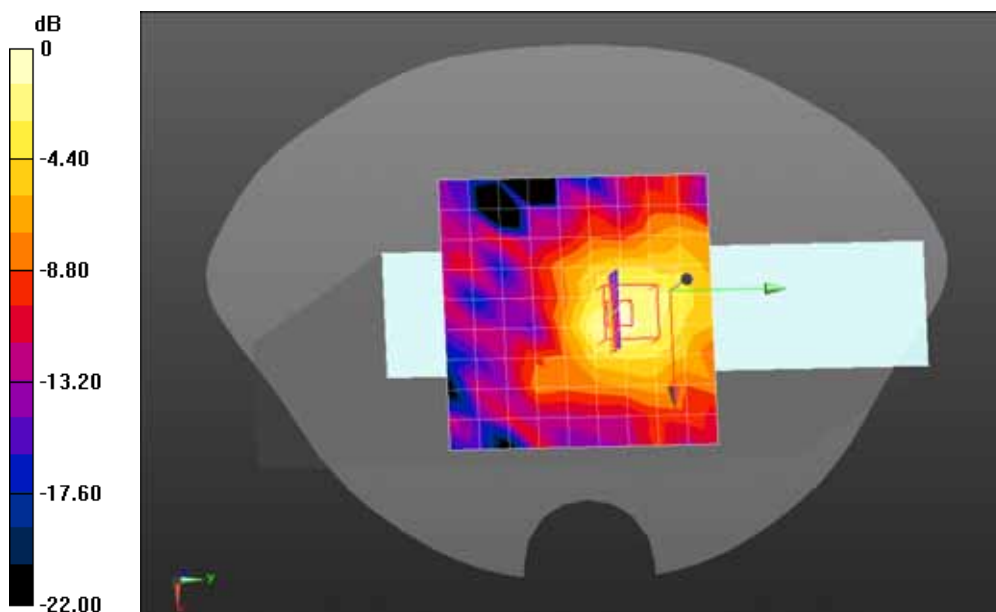

0 dB = 0.0206 mW/g = -33.72 dB mW/g

Z-Axis Plot

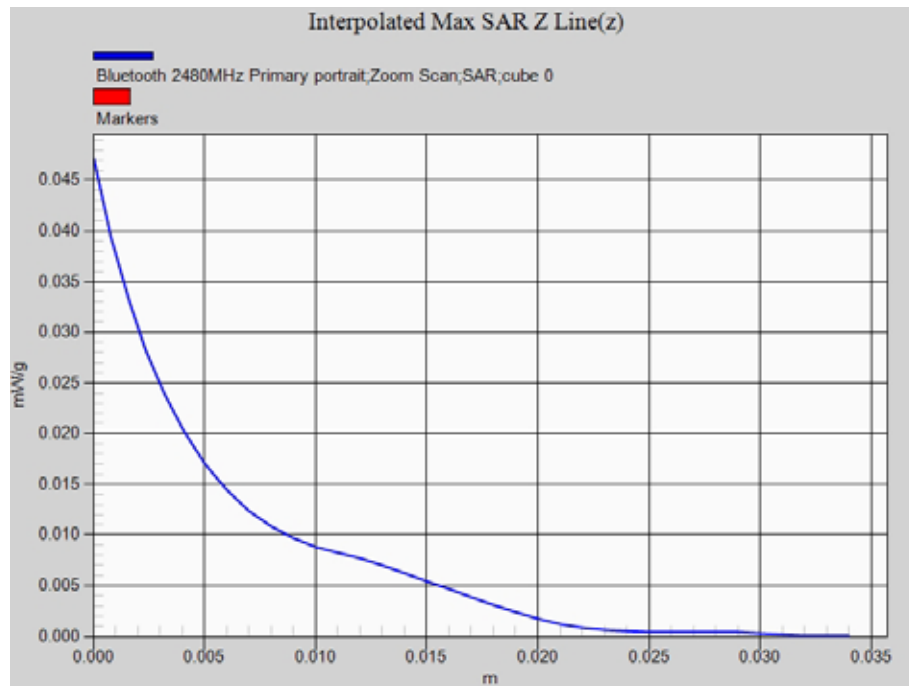

Appendix C. Test Setup Photographs & EUT Photographs

Antenna to Antenna/User Separation Distances

**Bottom of Tablet**

Primary landscape

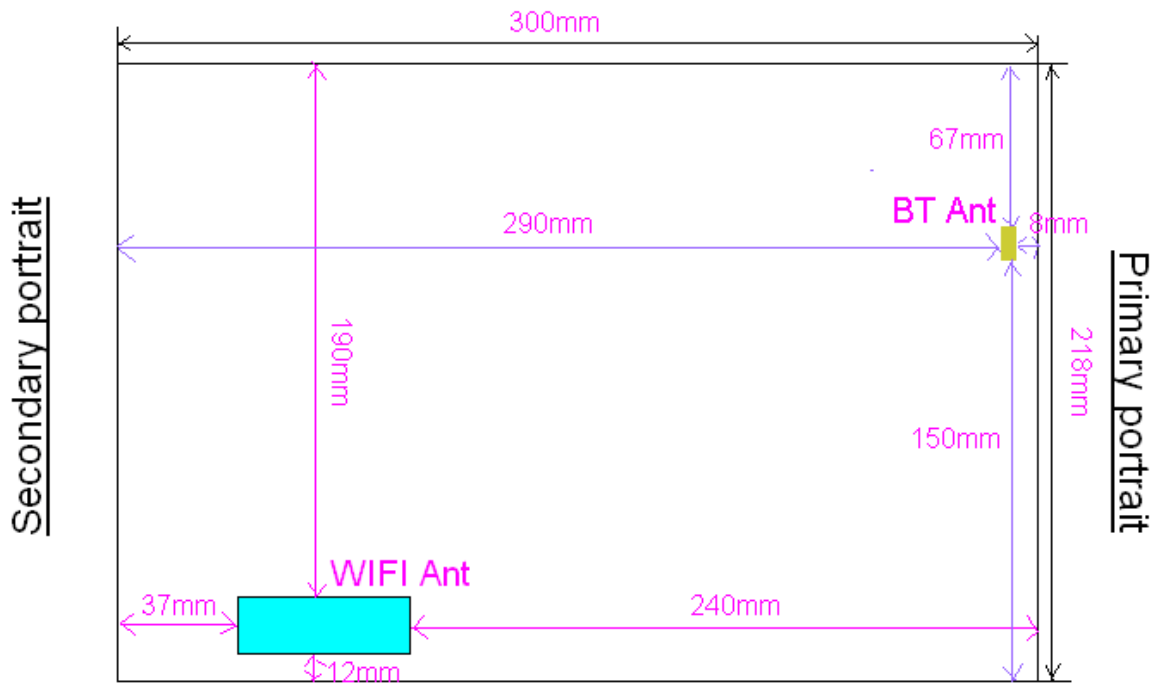

Secondary landscape

Antenna-to-user separation distances:	<p><b><u>WIFI Antenna</u></b></p> <p>Tablet-Bottom face: 6mm from WIFI Antenna-to-user</p> <p>Tablet-Edges with the following configurations</p> <ul style="list-style-type: none"> <li>● Primary landscape: 190mm from WIFI Antenna-to-user</li> <li>● Secondary landscape: 12mm from WIFI Antenna-to-user</li> <li>● Primary portrait: 240mm from WIFI Antenna-to-user</li> <li>● Secondary portrait: 37mm from WIFI Antenna-to-user</li> </ul>
	<p><b><u>Bluetooth Antenna</u></b></p> <p>Tablet-Bottom face: 6mm from WIFI Antenna-to-user</p> <p>Tablet-Edges with the following configurations</p> <ul style="list-style-type: none"> <li>● Primary landscape: 67mm from WIFI Antenna-to-user</li> <li>● Secondary landscape: 150mm from WIFI Antenna-to-user</li> <li>● Primary portrait: 8mm from WIFI Antenna-to-user</li> <li>● Secondary portrait: 290mm from WIFI Antenna-to-user</li> </ul>

**Test Setup Photographs**



WIFI Body SAR Bottom



WIFI Body SAR Secondary landscape



Bluetooth Body SAR Bottom

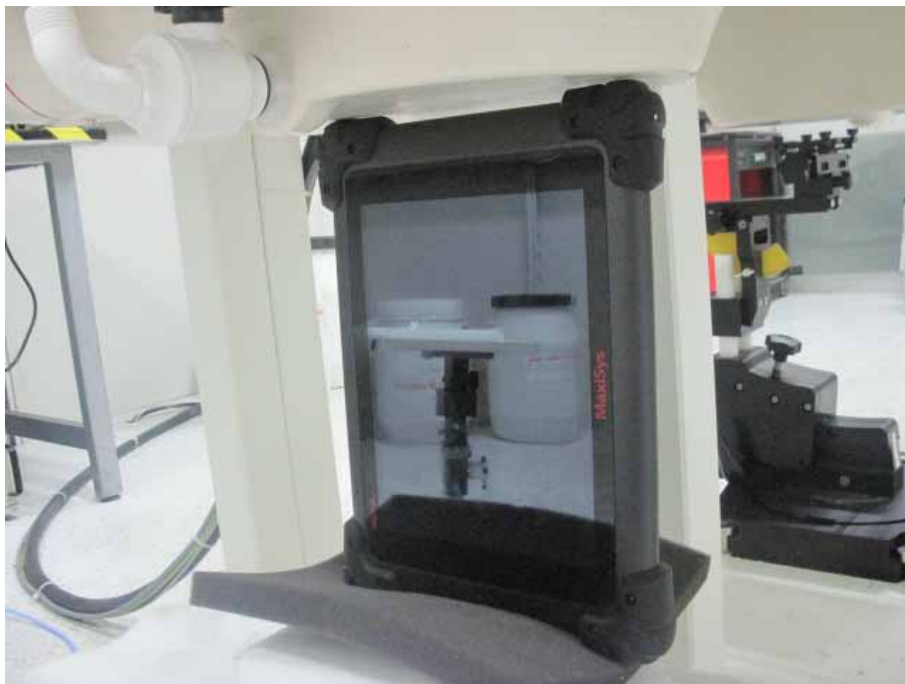

Bluetooth Body SAR Primary portrait

**Depth of the liquid in the phantom – Zoom in**

Note: The position used in the measurements were according to IEEE 1528 - 2003

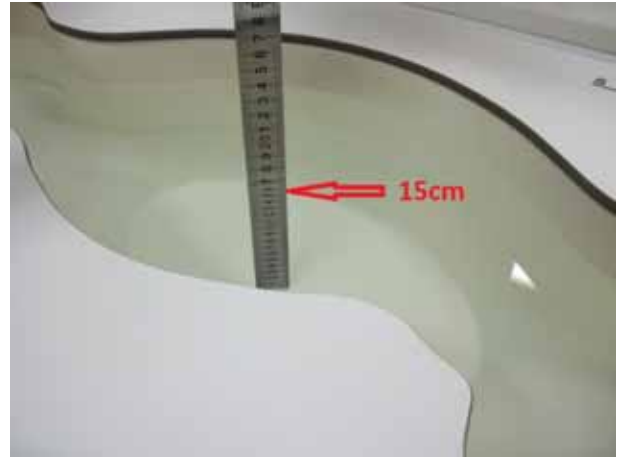
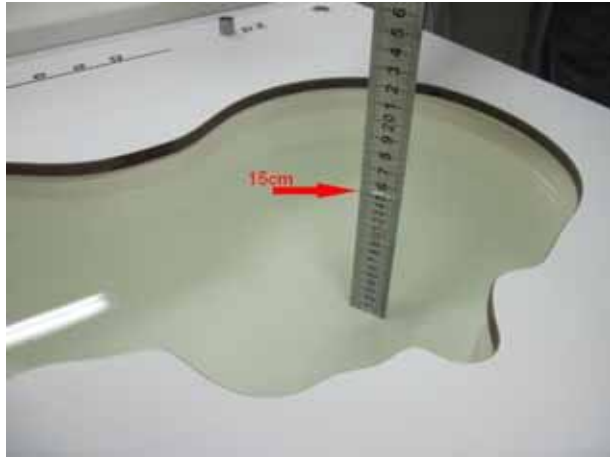



EUT Photographs

(1) EUT Photo



(2) EUT Photo



(3) EUT Photo



(4) EUT Photo



(5) EUT Photo



(6) EUT Photo

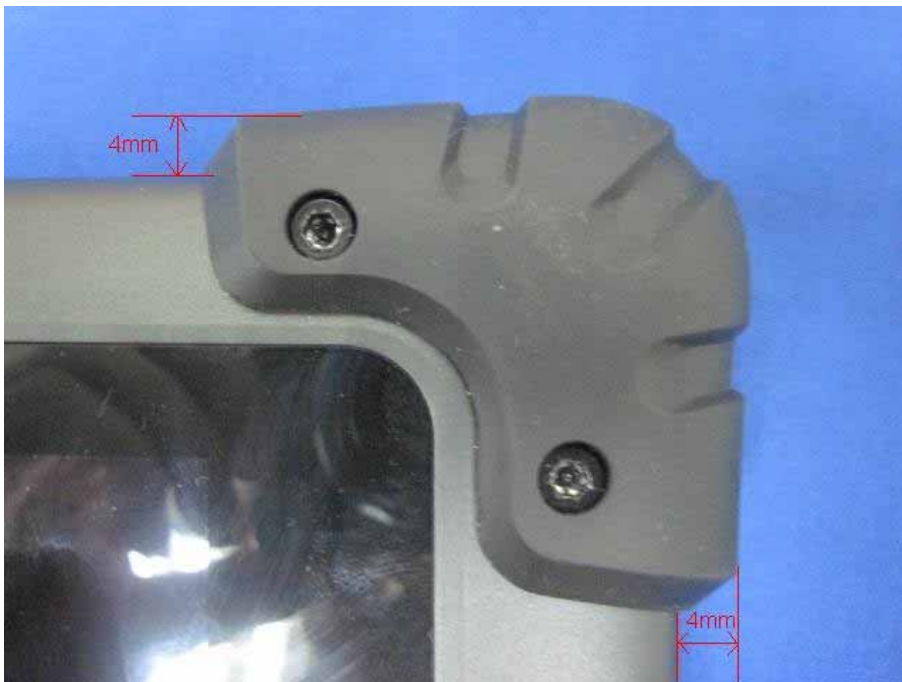

(7) EUT Photo

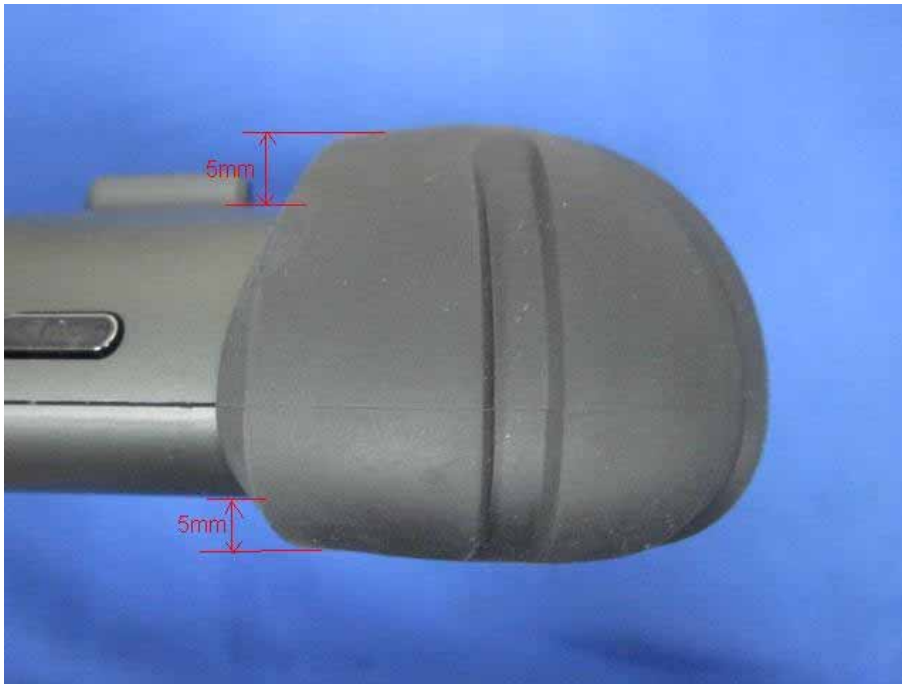

## Appendix D. Probe Calibration Data

**Calibration Laboratory of  
Schmid & Partner  
Engineering AG**  
Zeughausstrasse 43, 8004 Zurich, Switzerland



**S** Schweizerischer Kalibrierdienst  
**C** Service suisse d'étalonnage  
**S** Servizio svizzero di taratura  
Swiss Calibration Service

Accredited by the Swiss Accreditation Service (SAS)  
The Swiss Accreditation Service is one of the signatories to the EA  
Multilateral Agreement for the recognition of calibration certificates

Accreditation No.: **SCS 108**

Client **Quietek-CN (Auden)**

Certificate No: **EX3-3710\_Mar13**

### CALIBRATION CERTIFICATE

Object **EX3DV4 - SN:3710**

Calibration procedure(s) **QA CAL-01.v8, QA CAL-12.v7, QA CAL-14.v3, QA CAL-23.v4,  
QA CAL-25.v4  
Calibration procedure for dosimetric E-field probes**

Calibration date: **March 27, 2013**

This calibration certificate documents the traceability to national standards, which realize the physical units of measurements (SI).  
The measurements and the uncertainties with confidence probability are given on the following pages and are part of the certificate.

All calibrations have been conducted in the closed laboratory facility: environment temperature (22 ± 3)°C and humidity < 70%.

Calibration Equipment used (M&TE critical for calibration)

Primary Standards	ID	Cal Date (Certificate No.)	Scheduled Calibration
Power meter E4419B	GB41293874	29-Mar-12 (No. 217-01508)	Apr-13
Power sensor E4412A	MY41498087	29-Mar-12 (No. 217-01508)	Apr-13
Reference 3 dB Attenuator	SN: S5054 (3c)	27-Mar-12 (No. 217-01531)	Apr-13
Reference 20 dB Attenuator	SN: S5086 (20b)	27-Mar-12 (No. 217-01529)	Apr-13
Reference 30 dB Attenuator	SN: S5129 (30b)	27-Mar-12 (No. 217-01532)	Apr-13
Reference Probe ES3DV2	SN: 3013	28-Dec-12 (No. ES1-3013_Dec12)	Dec-12
DAE4	SN: 660	31-Jan-13 (No. DAE4-660_Jan13)	Jan-14
Secondary Standards	ID	Check Date (in house)	Scheduled Check
RF generator HP 8648C	US3642U01700	4-Aug-09 (in house check Apr-11)	In house check: Apr-13
Network Analyzer HP 8753E	US37390585	18-Oct-01 (in house check Oct-12)	In house check: Oct-13

Calibrated by:	Name <b>Claudio Leubler</b>	Function Laboratory Technician	Signature 
Approved by:	Name <b>Katja Pokovic</b>	Technical Manager	

Issued: April 2, 2013

This calibration certificate shall not be reproduced except in full without written approval of the laboratory.

**Calibration Laboratory of  
Schmid & Partner  
Engineering AG**  
Zeughausstrasse 43, 8004 Zurich, Switzerland



**S** Schweizerischer Kalibrierdienst  
**C** Service suisse d'étalonnage  
**S** Servizio svizzero di taratura  
**S** Swiss Calibration Service

Accredited by the Swiss Accreditation Service (SAS)  
The Swiss Accreditation Service is one of the signatories to the EA  
Multilateral Agreement for the recognition of calibration certificates

Accreditation No.: **SCS 108**

### Glossary:

TSL	tissue simulating liquid
NORM <sub>x,y,z</sub>	sensitivity in free space
ConvF	sensitivity in TSL / NORM <sub>x,y,z</sub>
DCP	diode compression point
CF	crest factor (1/duty_cycle) of the RF signal
A, B, C, D	modulation dependent linearization parameters
Polarization $\varphi$	$\varphi$ rotation around probe axis
Polarization $\theta$	$\theta$ rotation around an axis that is in the plane normal to probe axis (at measurement center), i.e., $\theta = 0$ is normal to probe axis

### Calibration is Performed According to the Following Standards:

- IEEE Std 1528-2003, "IEEE Recommended Practice for Determining the Peak Spatial-Averaged Specific Absorption Rate (SAR) in the Human Head from Wireless Communications Devices: Measurement Techniques", December 2003
- IEC 62209-1, "Procedure to measure the Specific Absorption Rate (SAR) for hand-held devices used in close proximity to the ear (frequency range of 300 MHz to 3 GHz)", February 2005

### Methods Applied and Interpretation of Parameters:

- NORM<sub>x,y,z</sub>:** Assessed for E-field polarization  $\theta = 0$  ( $f \leq 900$  MHz in TEM-cell;  $f > 1800$  MHz: R22 waveguide). NORM<sub>x,y,z</sub> are only intermediate values, i.e., the uncertainties of NORM<sub>x,y,z</sub> does not affect the E<sup>2</sup>-field uncertainty inside TSL (see below ConvF).
- NORM(f)<sub>x,y,z</sub> = NORM<sub>x,y,z</sub> \* frequency\_response** (see Frequency Response Chart). This linearization is implemented in DASY4 software versions later than 4.2. The uncertainty of the frequency response is included in the stated uncertainty of ConvF.
- DCP<sub>x,y,z</sub>:** DCP are numerical linearization parameters assessed based on the data of power sweep with CW signal (no uncertainty required). DCP does not depend on frequency nor media.
- PAR:** PAR is the Peak to Average Ratio that is not calibrated but determined based on the signal characteristics
- A<sub>x,y,z</sub>; B<sub>x,y,z</sub>; C<sub>x,y,z</sub>; D<sub>x,y,z</sub>; VR<sub>x,y,z</sub>; A, B, C, D** are numerical linearization parameters assessed based on the data of power sweep for specific modulation signal. The parameters do not depend on frequency nor media. VR is the maximum calibration range expressed in RMS voltage across the diode.
- ConvF and Boundary Effect Parameters:** Assessed in flat phantom using E-field (or Temperature Transfer Standard for  $f \leq 800$  MHz) and inside waveguide using analytical field distributions based on power measurements for  $f > 800$  MHz. The same setups are used for assessment of the parameters applied for boundary compensation (alpha, depth) of which typical uncertainty values are given. These parameters are used in DASY4 software to improve probe accuracy close to the boundary. The sensitivity in TSL corresponds to NORM<sub>x,y,z</sub> \* ConvF whereby the uncertainty corresponds to that given for ConvF. A frequency dependent ConvF is used in DASY version 4.4 and higher which allows extending the validity from  $\pm 50$  MHz to  $\pm 100$  MHz.
- Spherical isotropy (3D deviation from isotropy):** in a field of low gradients realized using a flat phantom exposed by a patch antenna.
- Sensor Offset:** The sensor offset corresponds to the offset of virtual measurement center from the probe tip (on probe axis). No tolerance required.

EX3DV4 – SN:3710

March 27, 2013

# Probe EX3DV4

## SN:3710

Manufactured: July 21, 2009  
Calibrated: March 27, 2013

Calibrated for DASY/EASY Systems  
(Note: non-compatible with DASY2 system!)

EX3DV4- SN:3710

March 27, 2013

## DASY/EASY - Parameters of Probe: EX3DV4 - SN:3710

### Basic Calibration Parameters

	Sensor X	Sensor Y	Sensor Z	Unc (k=2)
Norm ( $\mu\text{V}/(\text{V}/\text{m})^2$ ) <sup>a</sup>	0.51	0.56	0.45	$\pm 10.1\%$
DCP (mV) <sup>b</sup>	101.3	99.6	96.6	

### Modulation Calibration Parameters

UID	Communication System Name		A dB	B dB $\sqrt{\mu\text{V}}$	C	D dB	VR mV	Unc <sup>c</sup> (k=2)
0	CW	X	0.0	0.0	1.0	0.00	159.5	$\pm 2.7\%$
		Y	0.0	0.0	1.0		162.9	
		Z	0.0	0.0	1.0		159.4	

The reported uncertainty of measurement is stated as the standard uncertainty of measurement multiplied by the coverage factor k=2, which for a normal distribution corresponds to a coverage probability of approximately 95%.

<sup>a</sup> The uncertainties of NormX,Y,Z do not affect the E<sup>2</sup>-field uncertainty inside TSL (see Pages 5 and 6).

<sup>b</sup> Numerical linearization parameter: uncertainty not required.

<sup>c</sup> Uncertainty is determined using the max. deviation from linear response applying rectangular distribution and is expressed for the square of the field value.



EX3DV4- SN:3710

March 27, 2013

## DASY/EASY - Parameters of Probe: EX3DV4 - SN:3710

### Calibration Parameter Determined in Head Tissue Simulating Media

f (MHz) <sup>c</sup>	Relative Permittivity <sup>f</sup>	Conductivity (S/m) <sup>f</sup>	ConvF X	ConvF Y	ConvF Z	Alpha	Depth (mm)	Unct. (k=2)
450	43.5	0.87	9.87	9.87	9.87	0.14	1.30	± 13.4 %
750	41.9	0.89	9.94	9.94	9.94	0.29	0.99	± 12.0 %
835	41.5	0.90	9.52	9.52	9.52	0.39	0.83	± 12.0 %
900	41.5	0.97	9.50	9.50	9.50	0.70	0.63	± 12.0 %
1810	40.0	1.40	7.75	7.75	7.75	0.66	0.63	± 12.0 %
1950	40.0	1.40	7.47	7.47	7.47	0.75	0.59	± 12.0 %
2450	39.2	1.80	7.03	7.03	7.03	0.63	0.64	± 12.0 %
2600	39.0	1.96	6.83	6.83	6.83	0.50	0.74	± 12.0 %
3500	37.9	2.91	6.81	6.81	6.81	0.82	0.73	± 13.1 %
5200	36.0	4.66	4.86	4.86	4.86	0.45	1.80	± 13.1 %
5300	35.9	4.76	4.74	4.74	4.74	0.45	1.80	± 13.1 %
5500	35.6	4.96	4.50	4.50	4.50	0.50	1.80	± 13.1 %
5600	35.5	5.07	4.42	4.42	4.42	0.45	1.80	± 13.1 %
5800	35.3	5.27	4.43	4.43	4.43	0.50	1.80	± 13.1 %

<sup>c</sup> Frequency validity of ± 100 MHz only applies for DASY v4.4 and higher (see Page 2), else it is restricted to ± 50 MHz. The uncertainty is the RSS of the ConvF uncertainty at calibration frequency and the uncertainty for the indicated frequency band.

<sup>f</sup> At frequencies below 3 GHz, the validity of tissue parameters ( $\epsilon$  and  $\sigma$ ) can be relaxed to ± 10% if liquid compensation formula is applied to measured SAR values. At frequencies above 3 GHz, the validity of tissue parameters ( $\epsilon$  and  $\sigma$ ) is restricted to ± 5%. The uncertainty is the RSS of the ConvF uncertainty for indicated target tissue parameters.

EX3DV4- SN:3710

March 27, 2013

## DASY/EASY - Parameters of Probe: EX3DV4 - SN:3710

### Calibration Parameter Determined in Body Tissue Simulating Media

f (MHz) <sup>c</sup>	Relative Permittivity <sup>f</sup>	Conductivity (S/m) <sup>f</sup>	ConvF X	ConvF Y	ConvF Z	Alpha	Depth (mm)	Unct. (k=2)
450	56.7	0.94	10.89	10.89	10.89	0.05	1.20	± 13.4 %
750	55.5	0.96	9.60	9.60	9.60	0.48	0.83	± 12.0 %
835	55.2	0.97	9.41	9.41	9.41	0.38	0.90	± 12.0 %
900	55.0	1.05	9.30	9.30	9.30	0.80	0.63	± 12.0 %
1810	53.3	1.52	7.60	7.60	7.60	0.42	0.81	± 12.0 %
1950	53.3	1.52	7.62	7.62	7.62	0.34	0.98	± 12.0 %
2450	52.7	1.95	7.08	7.08	7.08	0.76	0.56	± 12.0 %
2600	52.5	2.16	6.88	6.88	6.88	0.80	0.50	± 12.0 %
3500	51.3	3.31	6.38	6.38	6.38	1.00	0.57	± 13.1 %
5200	49.0	5.30	4.32	4.32	4.32	0.45	1.90	± 13.1 %
5300	48.9	5.42	4.16	4.16	4.16	0.45	1.90	± 13.1 %
5500	48.6	5.65	3.87	3.87	3.87	0.50	1.90	± 13.1 %
5600	48.5	5.77	3.89	3.89	3.89	0.40	1.90	± 13.1 %
5800	48.2	6.00	4.05	4.05	4.05	0.50	1.90	± 13.1 %

<sup>c</sup> Frequency validity of ± 100 MHz only applies for DASY v4.4 and higher (see Page 2), else it is restricted to ± 50 MHz. The uncertainty is the RSS of the ConvF uncertainty at calibration frequency and the uncertainty for the indicated frequency band.

<sup>f</sup> At frequencies below 3 GHz, the validity of tissue parameters ( $\epsilon$  and  $\sigma$ ) can be relaxed to ± 10% if liquid compensation formula is applied to measured SAR values. At frequencies above 3 GHz, the validity of tissue parameters ( $\epsilon$  and  $\sigma$ ) is restricted to ± 5%. The uncertainty is the RSS of the ConvF uncertainty for indicated target tissue parameters.

EX30V4-SN:3710

March 27, 2013

### Frequency Response of E-Field (TEM-Cell: ifi110 EXX, Waveguide: R22)

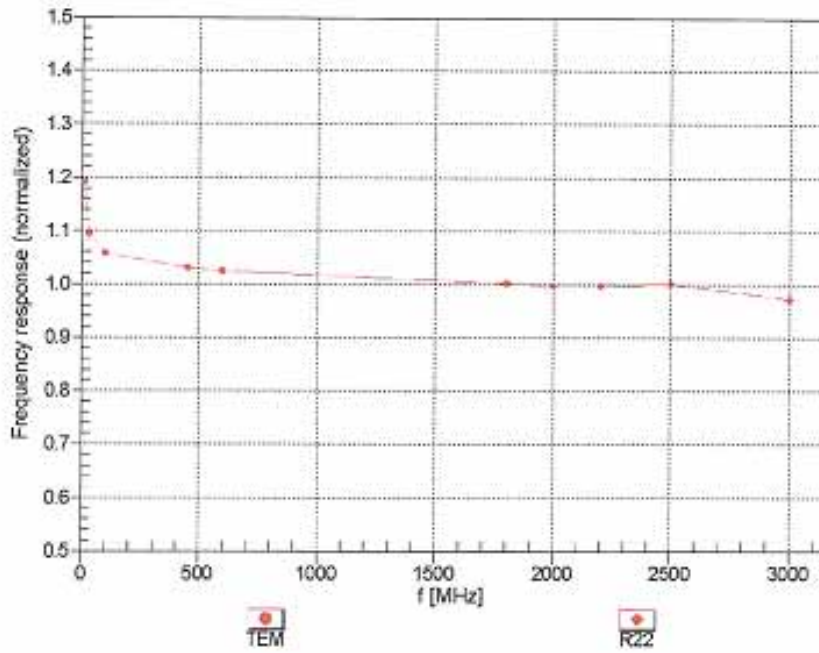

Uncertainty of Frequency Response of E-field:  $\pm 6.3\%$  (k=2)

EX3DV4-SN:3710

March 27, 2013

Receiving Pattern ( $\phi$ ),  $\theta = 0^\circ$

f=600 MHz, TEM

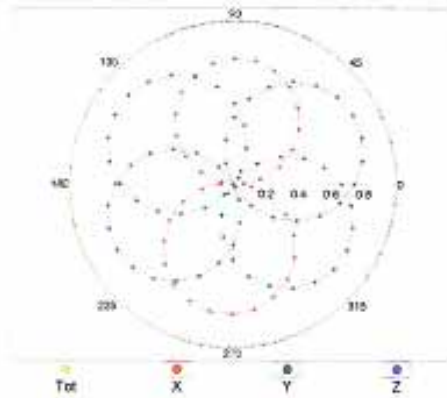

f=1800 MHz, R22

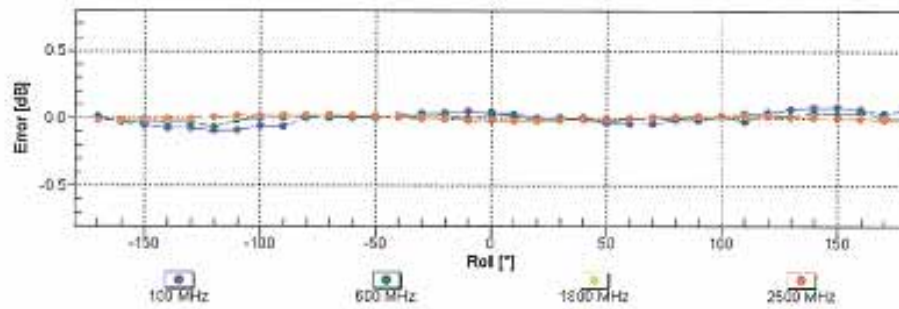
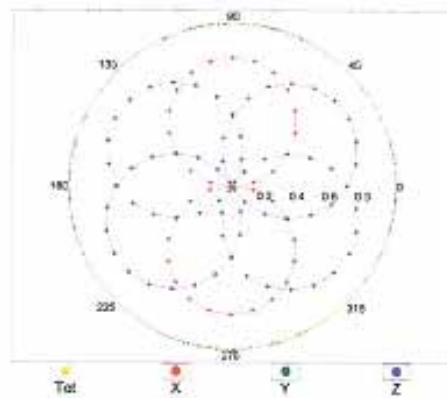

Uncertainty of Axial Isotropy Assessment:  $\pm 0.5\%$  (k=2)

EX3DV4-SN:3710

March 27, 2013

**Dynamic Range f(SAR<sub>head</sub>)**  
 (TEM cell , f = 900 MHz)

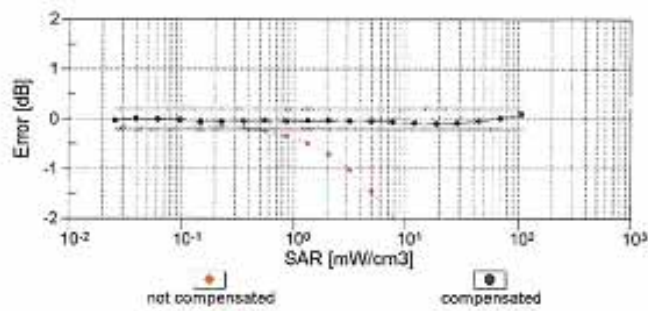
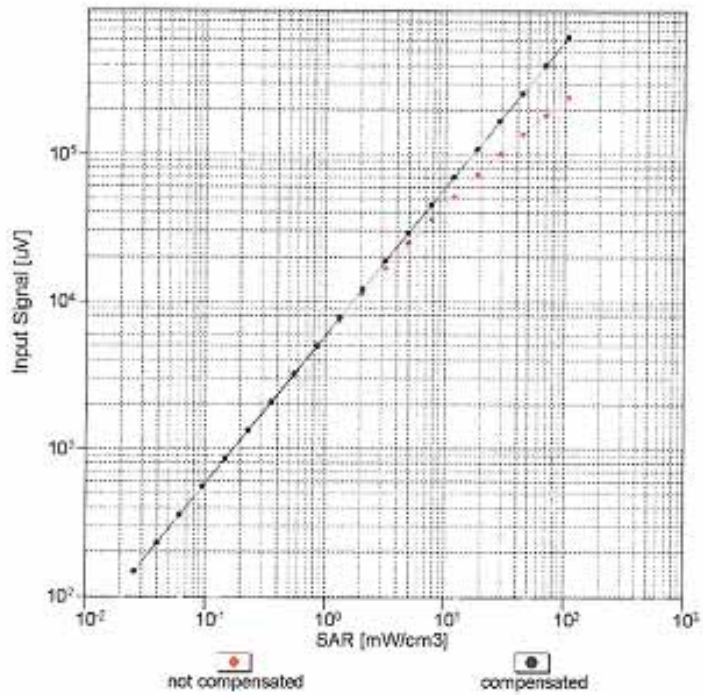

Uncertainty of Linearity Assessment:  $\pm 0.6\%$  (k=2)

EX3DV4- SN:3710

March 27, 2013

### Conversion Factor Assessment

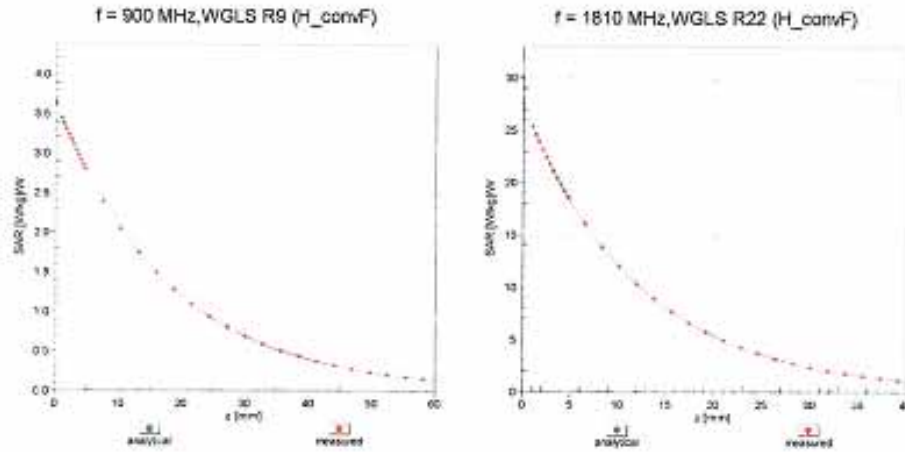

### Deviation from Isotropy in Liquid

Error ( $\phi, \theta$ ), f = 900 MHz

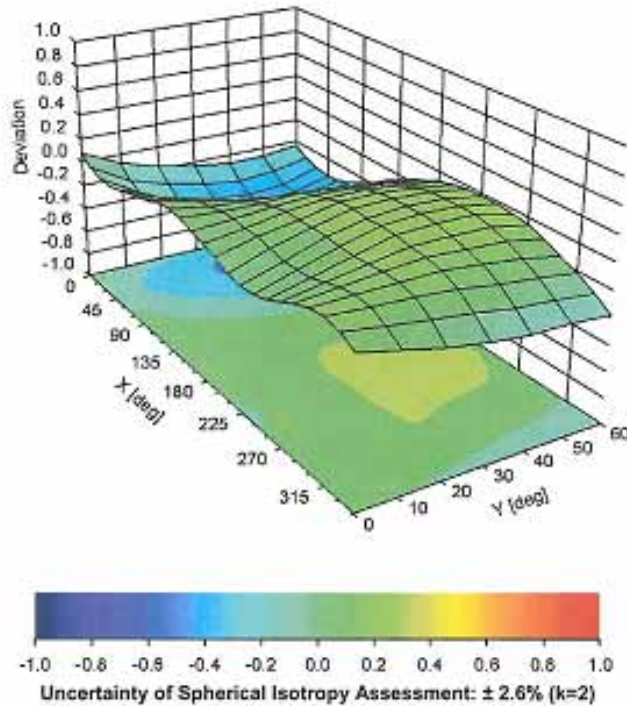

EX3DV4- SN:3710

March 27, 2013

**DASY/EASY - Parameters of Probe: EX3DV4 - SN:3710**

**Other Probe Parameters**

Sensor Arrangement	Triangular
Connector Angle (°)	-20.2
Mechanical Surface Detection Mode	enabled
Optical Surface Detection Mode	disabled
Probe Overall Length	337 mm
Probe Body Diameter	10 mm
Tip Length	9 mm
Tip Diameter	2.5 mm
Probe Tip to Sensor X Calibration Point	1 mm
Probe Tip to Sensor Y Calibration Point	1 mm
Probe Tip to Sensor Z Calibration Point	1 mm
Recommended Measurement Distance from Surface	2 mm

**Appendix E. Dipole Calibration Data**

Calibration Laboratory of  
Schmid & Partner  
Engineering AG  
Zeughausstrasse 43, 8004 Zurich, Switzerland



S Schweizerischer Kalibrierdienst  
S Service suisse d'étalonnage  
C Servizio svizzero di taratura  
S Swiss Calibration Service

Accredited by the Swiss Accreditation Service (SAS)  
The Swiss Accreditation Service is one of the signatories to the EA  
Multilateral Agreement for the recognition of calibration certificates

Accreditation No.: **SCS 108**

Client **Quietek-CN (Auden)**

Certificate No: **D900V2-1d096\_Feb12**

**CALIBRATION CERTIFICATE**

Object: **D900V2 - SN: 1d096**

Calibration procedure(s): **QA CAL-05.v8  
Calibration procedure for dipole validation kits above 700 MHz**

Calibration date: **February 17, 2012**

This calibration certificate documents the traceability to national standards, which realize the physical units of measurements (SI).  
The measurements and the uncertainties with confidence probability are given on the following pages and are part of the certificate.

All calibrations have been conducted in the closed laboratory facility: environment temperature (22 ± 3)°C and humidity < 70%.

Calibration Equipment used (M&TE critical for calibration)

Primary Standards	ID #	Cal Date (Certificate No.)	Scheduled Calibration
Power meter EPM-442A	GB37480704	05-Oct-11 (No. 217-01451)	Oct-12
Power sensor HP 8481A	US37292783	05-Oct-11 (No. 217-01451)	Oct-12
Reference 20 dB Attenuator	SN: 5086 (20g)	29-Mar-11 (No. 217-01368)	Apr-12
Type-N mismatch combination	SN: 5047.2 / 06327	29-Mar-11 (No. 217-01371)	Apr-12
Reference Probe ES3DV3	SN: 3205	30-Dec-11 (No. ES3-3205_Dec11)	Dec-12
DAE4	SN: 601	04-Jul-11 (No. DAE4-601_Jul11)	Jul-12
Secondary Standards	ID #	Check Date (in house)	Scheduled Check
Power sensor HP 8481A	MY41092317	18-Oct-02 (in house check Oct-11)	In house check: Oct-13
RF generator R&S SMT-06	100005	04-Aug-99 (in house check Oct-11)	In house check: Oct-13
Network Analyzer HP 8753E	US37390585 S4206	18-Oct-01 (in house check Oct-11)	In house check: Oct-12

Calibrated by:	Name <b>Israe El-Naouq</b>	Function <b>Laboratory Technician</b>	Signature 
Approved by:	<b>Katja Pokovic</b>	<b>Technical Manager</b>	

Issued: February 20, 2012

This calibration certificate shall not be reproduced except in full without written approval of the laboratory.



**Calibration Laboratory of  
Schmid & Partner  
Engineering AG**  
Zeughausstrasse 43, 8004 Zurich, Switzerland



**S** Schweizerischer Kalibrierdienst  
**C** Service suisse d'étalonnage  
**S** Servizio svizzero di taratura  
**S** Swiss Calibration Service

Accredited by the Swiss Accreditation Service (SAS)  
The Swiss Accreditation Service is one of the signatories to the EA  
Multilateral Agreement for the recognition of calibration certificates

Accreditation No.: **SCS 108**

**Glossary:**

TSL	tissue simulating liquid
ConvF	sensitivity in TSL / NORM x,y,z
N/A	not applicable or not measured

**Calibration is Performed According to the Following Standards:**

- a) IEEE Std 1528-2003, "IEEE Recommended Practice for Determining the Peak Spatial-Averaged Specific Absorption Rate (SAR) in the Human Head from Wireless Communications Devices: Measurement Techniques", December 2003
- b) IEC 62209-1, "Procedure to measure the Specific Absorption Rate (SAR) for hand-held devices used in close proximity to the ear (frequency range of 300 MHz to 3 GHz)", February 2005
- c) Federal Communications Commission Office of Engineering & Technology (FCC OET), "Evaluating Compliance with FCC Guidelines for Human Exposure to Radiofrequency Electromagnetic Fields; Additional Information for Evaluating Compliance of Mobile and Portable Devices with FCC Limits for Human Exposure to Radiofrequency Emissions", Supplement C (Edition 01-01) to Bulletin 65

**Additional Documentation:**

- d) DASY4/5 System Handbook

**Methods Applied and Interpretation of Parameters:**

- *Measurement Conditions:* Further details are available from the Validation Report at the end of the certificate. All figures stated in the certificate are valid at the frequency indicated.
- *Antenna Parameters with TSL:* The dipole is mounted with the spacer to position its feed point exactly below the center marking of the flat phantom section, with the arms oriented parallel to the body axis.
- *Feed Point Impedance and Return Loss:* These parameters are measured with the dipole positioned under the liquid filled phantom. The impedance stated is transformed from the measurement at the SMA connector to the feed point. The Return Loss ensures low reflected power. No uncertainty required.
- *Electrical Delay:* One-way delay between the SMA connector and the antenna feed point. No uncertainty required.
- *SAR measured:* SAR measured at the stated antenna input power.
- *SAR normalized:* SAR as measured, normalized to an input power of 1 W at the antenna connector.
- *SAR for nominal TSL parameters:* The measured TSL parameters are used to calculate the nominal SAR result.

**Measurement Conditions**

DASY system configuration, as far as not given on page 1.

DASY Version	DASY5	V52.8.0
Extrapolation	Advanced Extrapolation	
Phantom	Modular Flat Phantom	
Distance Dipole Center - TSL	15 mm	with Spacer
Zoom Scan Resolution	dx, dy, dz = 5 mm	
Frequency	900 MHz ± 1 MHz	

**Head TSL parameters**

The following parameters and calculations were applied.

	Temperature	Permittivity	Conductivity
Nominal Head TSL parameters	22.0 °C	41.5	0.97 mho/m
Measured Head TSL parameters	(22.0 ± 0.2) °C	40.3 ± 6 %	0.95 mho/m ± 6 %
Head TSL temperature change during test	< 0.5 °C	----	----

**SAR result with Head TSL**

SAR averaged over 1 cm <sup>3</sup> (1 g) of Head TSL	Condition	
SAR measured	250 mW input power	2.60 mW / g
SAR for nominal Head TSL parameters	normalized to 1W	10.5 mW / g ± 17.0 % (k=2)

SAR averaged over 10 cm <sup>3</sup> (10 g) of Head TSL	condition	
SAR measured	250 mW input power	1.67 mW / g
SAR for nominal Head TSL parameters	normalized to 1W	6.73 mW / g ± 16.5 % (k=2)

**Body TSL parameters**

The following parameters and calculations were applied.

	Temperature	Permittivity	Conductivity
Nominal Body TSL parameters	22.0 °C	55.0	1.05 mho/m
Measured Body TSL parameters	(22.0 ± 0.2) °C	55.1 ± 6 %	1.08 mho/m ± 6 %
Body TSL temperature change during test	< 0.5 °C	----	----

**SAR result with Body TSL**

SAR averaged over 1 cm <sup>3</sup> (1 g) of Body TSL	Condition	
SAR measured	250 mW input power	2.80 mW / g
SAR for nominal Body TSL parameters	normalized to 1W	11.0 mW / g ± 17.0 % (k=2)

SAR averaged over 10 cm <sup>3</sup> (10 g) of Body TSL	condition	
SAR measured	250 mW input power	1.80 mW / g
SAR for nominal Body TSL parameters	normalized to 1W	7.08 mW / g ± 16.5 % (k=2)

**Appendix**

**Antenna Parameters with Head TSL**

Impedance, transformed to feed point	53.1 $\Omega$ + 1.4 j $\Omega$
Return Loss	- 29.7 dB

**Antenna Parameters with Body TSL**

Impedance, transformed to feed point	48.5 $\Omega$ - 1.8 j $\Omega$
Return Loss	- 32.3 dB

**General Antenna Parameters and Design**

Electrical Delay (one direction)	1.410 ns
----------------------------------	----------

After long term use with 100W radiated power, only a slight warming of the dipole near the feedpoint can be measured.

The dipole is made of standard semirigid coaxial cable. The center conductor of the feeding line is directly connected to the second arm of the dipole. The antenna is therefore short-circuited for DC-signals. On some of the dipoles, small end caps are added to the dipole arms in order to improve matching when loaded according to the position as explained in the "Measurement Conditions" paragraph. The SAR data are not affected by this change. The overall dipole length is still according to the Standard.

No excessive force must be applied to the dipole arms, because they might bend or the soldered connections near the feedpoint may be damaged.

**Additional EUT Data**

Manufactured by	SPEAG
Manufactured on	September 22, 2009

**DASY5 Validation Report for Head TSL**

Date: 17.02.2012

Test Laboratory: SPEAG, Zurich, Switzerland

**DUT: Dipole 900 MHz; Type: D900V2; Serial: D900V2 - SN: 1d096**

Communication System: CW; Frequency: 900 MHz

Medium parameters used:  $f = 900$  MHz;  $\sigma = 0.95$  mho/m;  $\epsilon_r = 40.3$ ;  $\rho = 1000$  kg/m<sup>3</sup>

Phantom section: Flat Section

Measurement Standard: DASY5 (IEEE/IEC/ANSI C63.19-2007)

DASY52 Configuration:

- Probe: ES3DV3 - SN3205; ConvF(5.97, 5.97, 5.97); Calibrated: 30.12.2011
- Sensor-Surface: 3mm (Mechanical Surface Detection)
- Electronics: DAE4 Sn601; Calibrated: 04.07.2011
- Phantom: Flat Phantom 4.9L; Type: QD000P49AA; Serial: 1001
- DASY52 52.8.0(692); SEMCAD X 14.6.4(4989)

**Dipole Calibration for Head Tissue/Pin=250 mW, d=15mm/Zoom Scan (7x7x7)/Cube 0:**

Measurement grid: dx=5mm, dy=5mm, dz=5mm

Reference Value = 58.787 V/m; Power Drift = 0.01 dB

Peak SAR (extrapolated) = 3.8810

**SAR(1 g) = 2.6 mW/g; SAR(10 g) = 1.67 mW/g**

Maximum value of SAR (measured) = 3.046 mW/g

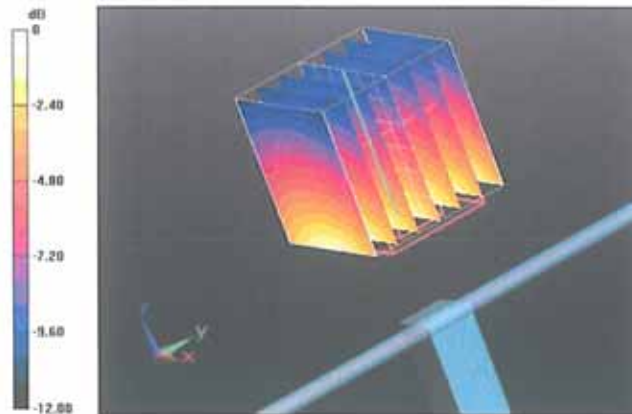

0 dB = 3.050mW/g = 9.69 dB mW/g

Impedance Measurement Plot for Head TSL

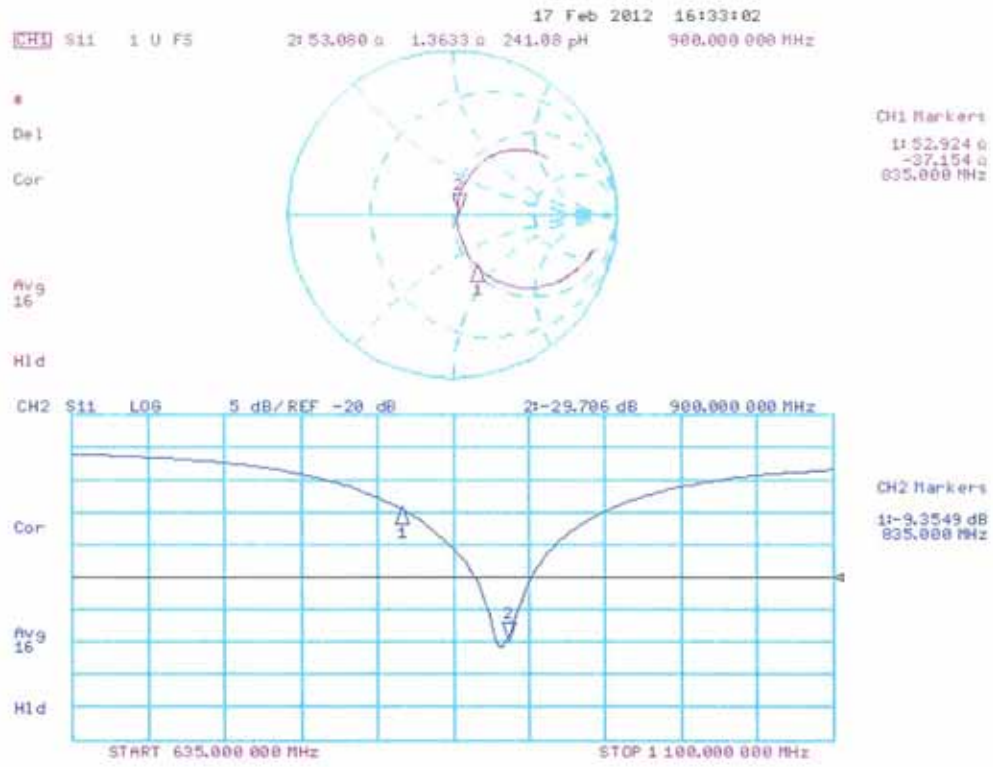

**DASY5 Validation Report for Body TSL**

Date: 17.02.2012

Test Laboratory: SPEAG, Zurich, Switzerland

**DUT: Dipole 900 MHz; Type: D900V2; Serial: D900V2 - SN: 1d096**

Communication System: CW; Frequency: 900 MHz

Medium parameters used:  $f = 900 \text{ MHz}$ ;  $\sigma = 1.08 \text{ mho/m}$ ;  $\epsilon_r = 55.1$ ;  $\rho = 1000 \text{ kg/m}^3$

Phantom section: Flat Section

Measurement Standard: DASY5 (IEEE/IEC/ANSI C63.19-2007)

DASY52 Configuration:

- Probe: ES3DV3 - SN3205; ConvF(5.94, 5.94, 5.94); Calibrated: 30.12.2011
- Sensor-Surface: 3mm (Mechanical Surface Detection)
- Electronics: DAE4 Sn601; Calibrated: 04.07.2011
- Phantom: Flat Phantom 4.9L; Type: QD000P49AA; Serial: 1001
- DASY52 52.8.0(692); SEMCAD X 14.6.4(4989)

**Dipole Calibration for Body Tissue/Pin=250 mW, d=15mm/Zoom Scan (7x7x7)/Cube 0:**

Measurement grid:  $dx=5\text{mm}$ ,  $dy=5\text{mm}$ ,  $dz=5\text{mm}$

Reference Value = 56.370 V/m; Power Drift = 0.0075 dB

Peak SAR (extrapolated) = 4.2490

**SAR(1 g) = 2.8 mW/g; SAR(10 g) = 1.8 mW/g**

Maximum value of SAR (measured) = 3.283 mW/g

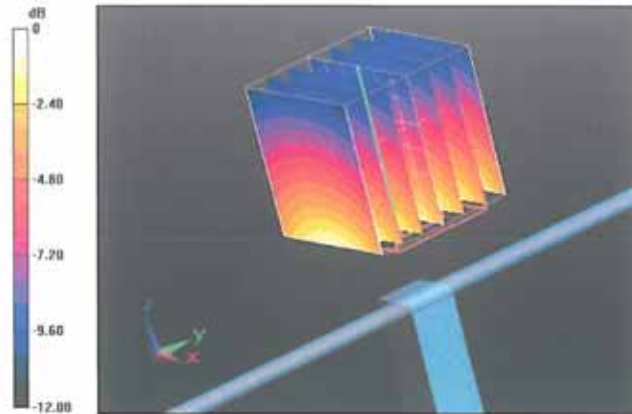

0 dB = 3.280mW/g = 10.32 dB mW/g

Impedance Measurement Plot for Body TSL

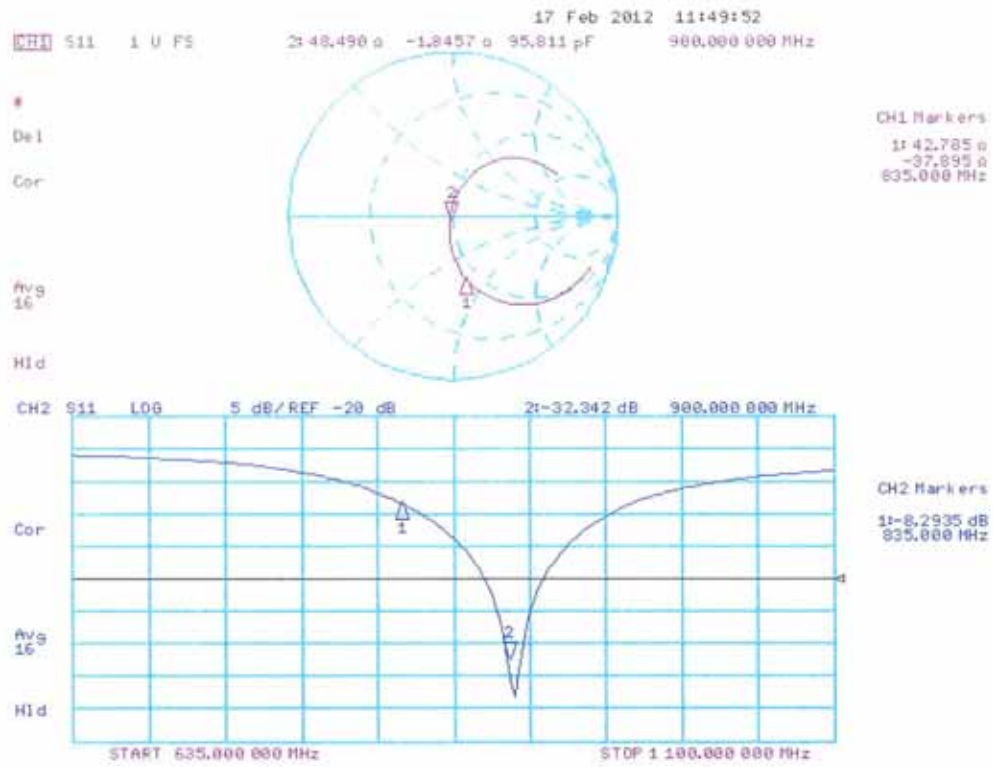

**Calibration Laboratory of  
Schmid & Partner  
Engineering AG**  
Zoughausstrasse 43, 8004 Zurich, Switzerland



**S** Schweizerischer Kalibrierdienst  
**C** Service suisse d'étalonnage  
**S** Servizio svizzero di taratura  
**S** Swiss Calibration Service

Accredited by the Swiss Accreditation Service (SAS)  
The Swiss Accreditation Service is one of the signatories to the EA  
Multilateral Agreement for the recognition of calibration certificates

Accreditation No.: **SCS 108**

Client **Quietek-CN (Auden)**

Certificate No: **D1800V2-2d179\_Feb12**

## CALIBRATION CERTIFICATE

Object: **D1800V2 - SN: 2d179**

Calibration procedure(s): **QA CAL-05.v8  
Calibration procedure for dipole validation kits above 700 MHz**

Calibration date: **February 22, 2012**

This calibration certificate documents the traceability to national standards, which realize the physical units of measurements (SI).  
The measurements and the uncertainties with confidence probability are given on the following pages and are part of the certificate.

All calibrations have been conducted in the closed laboratory facility: environment temperature (22 ± 3)°C and humidity < 70%.

Calibration Equipment used (M&TE critical for calibration)

Primary Standards	ID #	Cal Date (Certificate No.)	Scheduled Calibration
Power meter EPM-442A	GB37480704	05-Oct-11 (No. 217-01451)	Oct-12
Power sensor HP 8481A	US37292783	05-Oct-11 (No. 217-01451)	Oct-12
Reference 20 dB Attenuator	SN: 5086 (20g)	29-Mar-11 (No. 217-01368)	Apr-12
Type-N mismatch combination	SN: 5047.2 / 06327	29-Mar-11 (No. 217-01371)	Apr-12
Reference Probe ES3DV3	SN: 3205	30-Dec-11 (No. ES3-3205_Dec11)	Dec-12
DAE4	SN: 601	04-Jul-11 (No. DAE4-601_Jul11)	Jul-12
Secondary Standards	ID #	Check Date (in house)	Scheduled Check
Power sensor HP 8481A	MY41092317	18-Oct-02 (in house check Oct-11)	In house check: Oct-13
RF generator R&S SMT-06	100005	04-Aug-99 (in house check Oct-11)	In house check: Oct-13
Network Analyzer HP 8753E	US37390585 S4206	18-Oct-01 (in house check Oct-11)	In house check: Oct-12

	Name	Function	Signature
Calibrated by:	Israe El-Naouq	Laboratory Technician	
Approved by:	Katja Pokovic	Technical Manager	

Issued: February 22, 2012

This calibration certificate shall not be reproduced except in full without written approval of the laboratory.



**Calibration Laboratory of  
Schmid & Partner  
Engineering AG**  
Zeughausstrasse 43, 8004 Zurich, Switzerland



**S** Schweizerischer Kalibrierdienst  
**C** Service suisse d'étalonnage  
**S** Servizio svizzero di taratura  
**S** Swiss Calibration Service

Accredited by the Swiss Accreditation Service (SAS)  
The Swiss Accreditation Service is one of the signatories to the EA  
Multilateral Agreement for the recognition of calibration certificates

Accreditation No.: **SCS 108**

**Glossary:**

TSL	tissue simulating liquid
ConvF	sensitivity in TSL / NORM x,y,z
N/A	not applicable or not measured

**Calibration is Performed According to the Following Standards:**

- a) IEEE Std 1528-2003, "IEEE Recommended Practice for Determining the Peak Spatial-Averaged Specific Absorption Rate (SAR) in the Human Head from Wireless Communications Devices: Measurement Techniques", December 2003
- b) IEC 62209-1, "Procedure to measure the Specific Absorption Rate (SAR) for hand-held devices used in close proximity to the ear (frequency range of 300 MHz to 3 GHz)", February 2005
- c) Federal Communications Commission Office of Engineering & Technology (FCC OET), "Evaluating Compliance with FCC Guidelines for Human Exposure to Radiofrequency Electromagnetic Fields; Additional Information for Evaluating Compliance of Mobile and Portable Devices with FCC Limits for Human Exposure to Radiofrequency Emissions", Supplement C (Edition 01-01) to Bulletin 65

**Additional Documentation:**

- d) DASY4/5 System Handbook

**Methods Applied and Interpretation of Parameters:**

- *Measurement Conditions:* Further details are available from the Validation Report at the end of the certificate. All figures stated in the certificate are valid at the frequency indicated.
- *Antenna Parameters with TSL:* The dipole is mounted with the spacer to position its feed point exactly below the center marking of the flat phantom section, with the arms oriented parallel to the body axis.
- *Feed Point Impedance and Return Loss:* These parameters are measured with the dipole positioned under the liquid filled phantom. The impedance stated is transformed from the measurement at the SMA connector to the feed point. The Return Loss ensures low reflected power. No uncertainty required.
- *Electrical Delay:* One-way delay between the SMA connector and the antenna feed point. No uncertainty required.
- *SAR measured:* SAR measured at the stated antenna input power.
- *SAR normalized:* SAR as measured, normalized to an input power of 1 W at the antenna connector.
- *SAR for nominal TSL parameters:* The measured TSL parameters are used to calculate the nominal SAR result.

**Measurement Conditions**

DASY system configuration, as far as not given on page 1.

DASY Version	DASY5	V52.8.0
Extrapolation	Advanced Extrapolation	
Phantom	Modular Flat Phantom	
Distance Dipole Center - TSL	10 mm	with Spacer
Zoom Scan Resolution	dx, dy, dz = 5 mm	
Frequency	1800 MHz ± 1 MHz	

**Head TSL parameters**

The following parameters and calculations were applied.

	Temperature	Permittivity	Conductivity
Nominal Head TSL parameters	22.0 °C	40.0	1.40 mho/m
Measured Head TSL parameters	(22.0 ± 0.2) °C	40.5 ± 6 %	1.34 mho/m ± 6 %
Head TSL temperature change during test	< 0.5 °C	----	----

**SAR result with Head TSL**

SAR averaged over 1 cm <sup>3</sup> (1 g) of Head TSL	Condition	
SAR measured	250 mW input power	9.17 mW / g
SAR for nominal Head TSL parameters	normalized to 1W	<b>37.8 mW / g ± 17.0 % (k=2)</b>

SAR averaged over 10 cm <sup>3</sup> (10 g) of Head TSL	condition	
SAR measured	250 mW input power	4.91 mW / g
SAR for nominal Head TSL parameters	normalized to 1W	<b>20.0 mW / g ± 16.5 % (k=2)</b>

**Body TSL parameters**

The following parameters and calculations were applied.

	Temperature	Permittivity	Conductivity
Nominal Body TSL parameters	22.0 °C	53.3	1.52 mho/m
Measured Body TSL parameters	(22.0 ± 0.2) °C	53.1 ± 6 %	1.49 mho/m ± 6 %
Body TSL temperature change during test	< 0.5 °C	----	----

**SAR result with Body TSL**

SAR averaged over 1 cm <sup>3</sup> (1 g) of Body TSL	Condition	
SAR measured	250 mW input power	9.27 mW / g
SAR for nominal Body TSL parameters	normalized to 1W	<b>37.5 mW / g ± 17.0 % (k=2)</b>

SAR averaged over 10 cm <sup>3</sup> (10 g) of Body TSL	condition	
SAR measured	250 mW input power	4.92 mW / g
SAR for nominal Body TSL parameters	normalized to 1W	<b>19.8 mW / g ± 16.5 % (k=2)</b>

**Appendix**

**Antenna Parameters with Head TSL**

Impedance, transformed to feed point	50.2 $\Omega$ - 2.9 j $\Omega$
Return Loss	- 30.7 dB

**Antenna Parameters with Body TSL**

Impedance, transformed to feed point	46.1 $\Omega$ - 2.8 j $\Omega$
Return Loss	- 26.0 dB

**General Antenna Parameters and Design**

Electrical Delay (one direction)	1.214 ns
----------------------------------	----------

After long term use with 100W radiated power, only a slight warming of the dipole near the feedpoint can be measured.

The dipole is made of standard semirigid coaxial cable. The center conductor of the feeding line is directly connected to the second arm of the dipole. The antenna is therefore short-circuited for DC-signals. On some of the dipoles, small end caps are added to the dipole arms in order to improve matching when loaded according to the position as explained in the "Measurement Conditions" paragraph. The SAR data are not affected by this change. The overall dipole length is still according to the Standard.

No excessive force must be applied to the dipole arms, because they might bend or the soldered connections near the feedpoint may be damaged.

**Additional EUT Data**

Manufactured by	SPEAG
Manufactured on	September 05, 2008

## DASY5 Validation Report for Head TSL

Date: 22.02.2012

Test Laboratory: SPEAG, Zurich, Switzerland

**DUT: Dipole 1800 MHz; Type: D1800V2; Serial: D1800V2 - SN: 2d179**

Communication System: CW; Frequency: 1800 MHz

Medium parameters used:  $f = 1800$  MHz;  $\sigma = 1.34$  mho/m;  $\epsilon_r = 40.5$ ;  $\rho = 1000$  kg/m<sup>3</sup>

Phantom section: Flat Section

Measurement Standard: DASY5 (IEEE/IEC/ANSI C63.19-2007)

DASY52 Configuration:

- Probe: ES3DV3 - SN3205; ConvF(5.07, 5.07, 5.07); Calibrated: 30.12.2011
- Sensor-Surface: 3mm (Mechanical Surface Detection)
- Electronics: DAE4 Sn601; Calibrated: 04.07.2011
- Phantom: Flat Phantom 5.0 (front); Type: QD000P50AA; Serial: 1001
- DASY52 52.8.0(692); SEMCAD X 14.6.4(4989)

### Dipole Calibration for Head Tissue/Pin=250 mW, d=10mm/Zoom Scan (7x7x7)/Cube 0:

Measurement grid: dx=5mm, dy=5mm, dz=5mm

Reference Value = 95.908 V/m; Power Drift = 0.04 dB

Peak SAR (extrapolated) = 16.0120

**SAR(1 g) = 9.17 mW/g; SAR(10 g) = 4.91 mW/g**

Maximum value of SAR (measured) = 11.315 mW/g

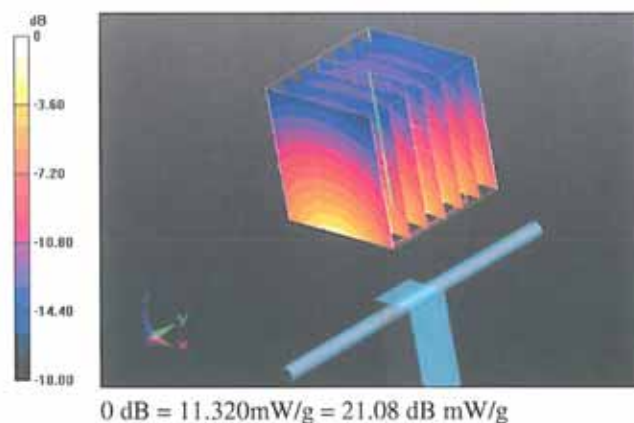

Impedance Measurement Plot for Head TSL

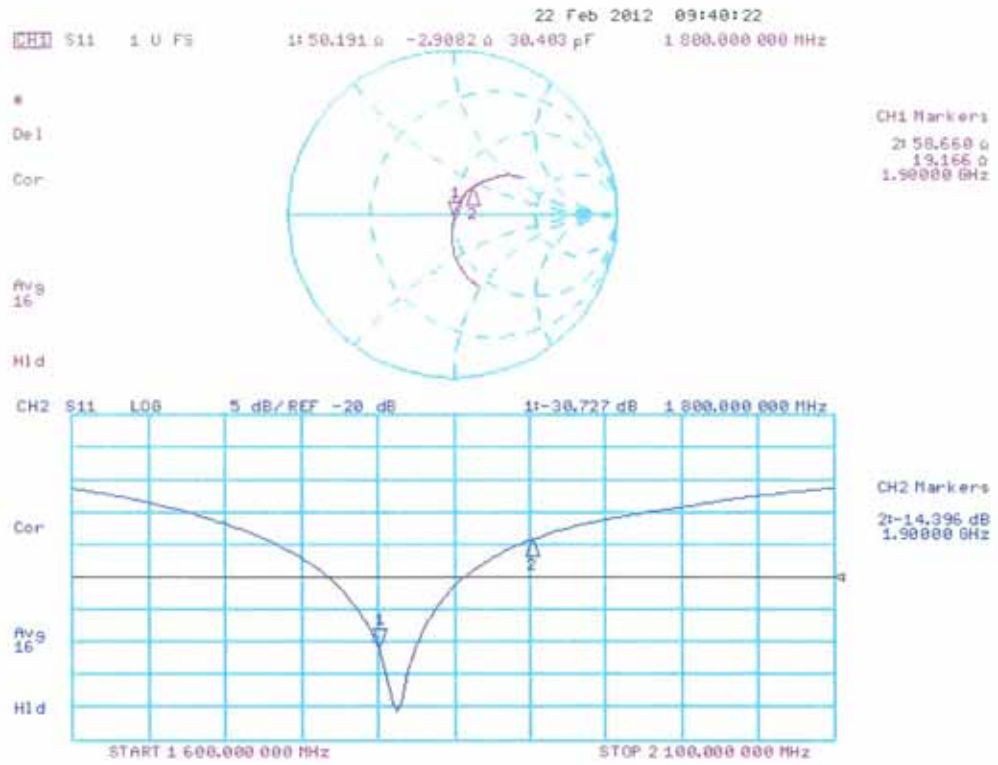

## DASY5 Validation Report for Body TSL

Date: 22.02.2012

Test Laboratory: SPEAG, Zurich, Switzerland

**DUT: Dipole 1800 MHz; Type: D1800V2; Serial: D1800V2 - SN: 2d179**

Communication System: CW; Frequency: 1800 MHz

Medium parameters used:  $f = 1800$  MHz;  $\sigma = 1.49$  mho/m;  $\epsilon_r = 53.1$ ;  $\rho = 1000$  kg/m<sup>3</sup>

Phantom section: Flat Section

Measurement Standard: DASY5 (IEEE/IEC/ANSI C63.19-2007)

DASY52 Configuration:

- Probe: ES3DV3 - SN3205; ConvF(4.74, 4.74, 4.74); Calibrated: 30.12.2011
- Sensor-Surface: 3mm (Mechanical Surface Detection)
- Electronics: DAE4 Sn601; Calibrated: 04.07.2011
- Phantom: Flat Phantom 5.0 (back); Type: QD000P50AA; Serial: 1002
- DASY52 52.8.0(692); SEMCAD X 14.6.4(4989)

### Dipole Calibration for Body Tissue/Pin=250 mW, d=10mm/Zoom Scan (7x7x7)/Cube 0:

Measurement grid: dx=5mm, dy=5mm, dz=5mm

Reference Value = 92.820 V/m; Power Drift = 0.0038 dB

Peak SAR (extrapolated) = 16.0810

**SAR(1 g) = 9.27 mW/g; SAR(10 g) = 4.92 mW/g**

Maximum value of SAR (measured) = 11.751 mW/g

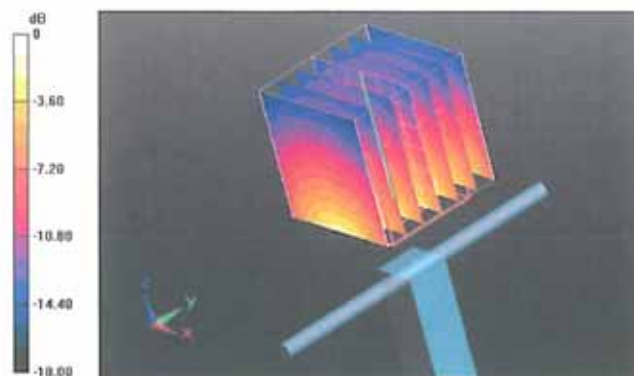

0 dB = 11.750mW/g = 21.40 dB mW/g

Impedance Measurement Plot for Body TSL

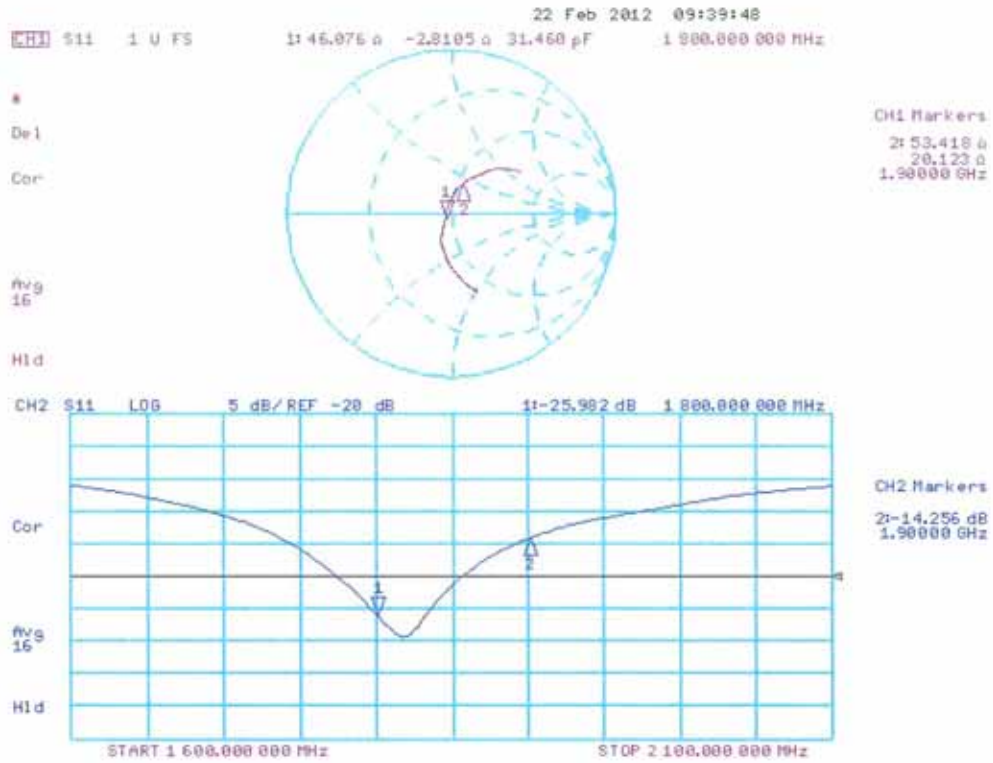

**Calibration Laboratory of  
Schmid & Partner  
Engineering AG**  
Zeughausstrasse 43, 8004 Zurich, Switzerland



**S** Schweizerischer Kalibrierdienst  
**C** Service suisse d'étalonnage  
**S** Servizio svizzero di taratura  
**S** Swiss Calibration Service

Accredited by the Swiss Accreditation Service (SAS)  
The Swiss Accreditation Service is one of the signatories to the EA  
Multilateral Agreement for the recognition of calibration certificates

Accreditation No.: **SCS 108**

Client **Quietek-CN (Auden)**

Certificate No: **D1900V2-5d121\_Feb12**

## CALIBRATION CERTIFICATE

Object **D1900V2 - SN: 5d121**

Calibration procedure(s) **QA CAL-05.v8  
Calibration procedure for dipole validation kits above 700 MHz**

Calibration date: **February 22, 2012**

This calibration certificate documents the traceability to national standards, which realize the physical units of measurements (SI).  
The measurements and the uncertainties with confidence probability are given on the following pages and are part of the certificate.

All calibrations have been conducted in the closed laboratory facility: environment temperature (22 ± 3)°C and humidity < 70%.

Calibration Equipment used (M&TE critical for calibration)

Primary Standards	ID #	Cal Date (Certificate No.)	Scheduled Calibration
Power meter EPM-442A	GB37480704	05-Oct-11 (No. 217-01451)	Oct-12
Power sensor HP 8481A	US37292783	05-Oct-11 (No. 217-01451)	Oct-12
Reference 20 dB Attenuator	SN: 5086 (20g)	29-Mar-11 (No. 217-01368)	Apr-12
Type-N mismatch combination	SN: 6047.2 / 06327	29-Mar-11 (No. 217-01371)	Apr-12
Reference Probe ES3DV3	SN: 3205	30-Dec-11 (No. ES3-3205_Dec11)	Dec-12
DAE4	SN: 601	04-Jul-11 (No. DAE4-601_Jul11)	Jul-12
Secondary Standards	ID #	Check Date (in house)	Scheduled Check
Power sensor HP 8481A	MY41092317	18-Oct-02 (in house check Oct-11)	In house check: Oct-13
RF generator R&S SMT-06	100005	04-Aug-99 (in house check Oct-11)	In house check: Oct-13
Network Analyzer HP 8753E	US37390585 S4206	18-Oct-01 (in house check Oct-11)	In house check: Oct-12

Calibrated by:	Name <b>Israe El-Nacouq</b>	Function <b>Laboratory Technician</b>	Signature 
Approved by:	<b>Katja Pokovic</b>	<b>Technical Manager</b>	

Issued: February 22, 2012

This calibration certificate shall not be reproduced except in full without written approval of the laboratory.



**Calibration Laboratory of  
Schmid & Partner  
Engineering AG**  
Zeughausstrasse 43, 8004 Zurich, Switzerland



**S** Schweizerischer Kalibrierdienst  
**C** Service suisse d'étalonnage  
**S** Servizio svizzero di taratura  
**S** Swiss Calibration Service

Accredited by the Swiss Accreditation Service (SAS)  
The Swiss Accreditation Service is one of the signatories to the EA  
Multilateral Agreement for the recognition of calibration certificates

Accreditation No.: **SCS 108**

**Glossary:**

TSL tissue simulating liquid  
ConvF sensitivity in TSL / NORM x,y,z  
N/A not applicable or not measured

**Calibration is Performed According to the Following Standards:**

- a) IEEE Std 1528-2003, "IEEE Recommended Practice for Determining the Peak Spatial-Averaged Specific Absorption Rate (SAR) in the Human Head from Wireless Communications Devices: Measurement Techniques", December 2003
- b) IEC 62209-1, "Procedure to measure the Specific Absorption Rate (SAR) for hand-held devices used in close proximity to the ear (frequency range of 300 MHz to 3 GHz)", February 2005
- c) Federal Communications Commission Office of Engineering & Technology (FCC OET), "Evaluating Compliance with FCC Guidelines for Human Exposure to Radiofrequency Electromagnetic Fields; Additional Information for Evaluating Compliance of Mobile and Portable Devices with FCC Limits for Human Exposure to Radiofrequency Emissions", Supplement C (Edition 01-01) to Bulletin 65

**Additional Documentation:**

- d) DASy4/5 System Handbook

**Methods Applied and Interpretation of Parameters:**

- *Measurement Conditions:* Further details are available from the Validation Report at the end of the certificate. All figures stated in the certificate are valid at the frequency indicated.
- *Antenna Parameters with TSL:* The dipole is mounted with the spacer to position its feed point exactly below the center marking of the flat phantom section, with the arms oriented parallel to the body axis.
- *Feed Point Impedance and Return Loss:* These parameters are measured with the dipole positioned under the liquid filled phantom. The impedance stated is transformed from the measurement at the SMA connector to the feed point. The Return Loss ensures low reflected power. No uncertainty required.
- *Electrical Delay:* One-way delay between the SMA connector and the antenna feed point. No uncertainty required.
- *SAR measured:* SAR measured at the stated antenna input power.
- *SAR normalized:* SAR as measured, normalized to an input power of 1 W at the antenna connector.
- *SAR for nominal TSL parameters:* The measured TSL parameters are used to calculate the nominal SAR result.

## Measurement Conditions

DASY system configuration, as far as not given on page 1.

DASY Version	DASY5	V52.8.0
Extrapolation	Advanced Extrapolation	
Phantom	Modular Flat Phantom	
Distance Dipole Center - TSL	10 mm	with Spacer
Zoom Scan Resolution	dx, dy, dz = 5 mm	
Frequency	1900 MHz ± 1 MHz	

## Head TSL parameters

The following parameters and calculations were applied.

	Temperature	Permittivity	Conductivity
Nominal Head TSL parameters	22.0 °C	40.0	1.40 mho/m
Measured Head TSL parameters	(22.0 ± 0.2) °C	40.4 ± 6 %	1.40 mho/m ± 6 %
Head TSL temperature change during test	< 0.5 °C	----	----

## SAR result with Head TSL

SAR averaged over 1 cm <sup>3</sup> (1 g) of Head TSL	Condition	
SAR measured	250 mW input power	9.84 mW / g
SAR for nominal Head TSL parameters	normalized to 1W	<b>39.4 mW / g ± 17.0 % (k=2)</b>

SAR averaged over 10 cm <sup>3</sup> (10 g) of Head TSL	condition	
SAR measured	250 mW input power	5.19 mW / g
SAR for nominal Head TSL parameters	normalized to 1W	<b>20.8 mW / g ± 16.5 % (k=2)</b>

## Body TSL parameters

The following parameters and calculations were applied.

	Temperature	Permittivity	Conductivity
Nominal Body TSL parameters	22.0 °C	53.3	1.52 mho/m
Measured Body TSL parameters	(22.0 ± 0.2) °C	53.0 ± 6 %	1.56 mho/m ± 6 %
Body TSL temperature change during test	< 0.5 °C	----	----

## SAR result with Body TSL

SAR averaged over 1 cm <sup>3</sup> (1 g) of Body TSL	Condition	
SAR measured	250 mW input power	9.84 mW / g
SAR for nominal Body TSL parameters	normalized to 1W	<b>38.7 mW / g ± 17.0 % (k=2)</b>

SAR averaged over 10 cm <sup>3</sup> (10 g) of Body TSL	condition	
SAR measured	250 mW input power	5.15 mW / g
SAR for nominal Body TSL parameters	normalized to 1W	<b>20.4 mW / g ± 16.5 % (k=2)</b>

**Appendix**

**Antenna Parameters with Head TSL**

Impedance, transformed to feed point	51.6 $\Omega$ + 7.2 j $\Omega$
Return Loss	- 22.8 dB

**Antenna Parameters with Body TSL**

Impedance, transformed to feed point	47.4 $\Omega$ + 7.4 j $\Omega$
Return Loss	- 21.9 dB

**General Antenna Parameters and Design**

Electrical Delay (one direction)	1.205 ns
----------------------------------	----------

After long term use with 100W radiated power, only a slight warming of the dipole near the feedpoint can be measured.

The dipole is made of standard semirigid coaxial cable. The center conductor of the feeding line is directly connected to the second arm of the dipole. The antenna is therefore short-circuited for DC-signals. On some of the dipoles, small end caps are added to the dipole arms in order to improve matching when loaded according to the position as explained in the "Measurement Conditions" paragraph. The SAR data are not affected by this change. The overall dipole length is still according to the Standard.

No excessive force must be applied to the dipole arms, because they might bend or the soldered connections near the feedpoint may be damaged.

**Additional EUT Data**

Manufactured by	SPEAG
Manufactured on	August 25, 2009

## DASY5 Validation Report for Head TSL

Date: 22.02.2012

Test Laboratory: SPEAG, Zurich, Switzerland

**DUT: Dipole 1900 MHz; Type: D1900V2; Serial: D1900V2 - SN: 5d121**

Communication System: CW; Frequency: 1900 MHz

Medium parameters used:  $f = 1900$  MHz;  $\sigma = 1.4$  mho/m;  $\epsilon_r = 40.4$ ;  $\rho = 1000$  kg/m<sup>3</sup>

Phantom section: Flat Section

Measurement Standard: DASY5 (IEEE/IEC/ANSI C63.19-2007)

DASY52 Configuration:

- Probe: ES3DV3 - SN3205; ConvF(5.01, 5.01, 5.01); Calibrated: 30.12.2011
- Sensor-Surface: 3mm (Mechanical Surface Detection)
- Electronics: DAE4 Sn601; Calibrated: 04.07.2011
- Phantom: Flat Phantom 5.0 (front); Type: QD000P50AA; Serial: 1001
- DASY52 52.8.0(692); SEMCAD X 14.6.4(4989)

### Dipole Calibration for Head Tissue/Pin=250 mW, d=10mm/Zoom Scan (7x7x7)/Cube 0:

Measurement grid: dx=5mm, dy=5mm, dz=5mm

Reference Value = 96.900 V/m; Power Drift = 0.04 dB

Peak SAR (extrapolated) = 17.5160

**SAR(1 g) = 9.84 mW/g; SAR(10 g) = 5.19 mW/g**

Maximum value of SAR (measured) = 12.195 mW/g

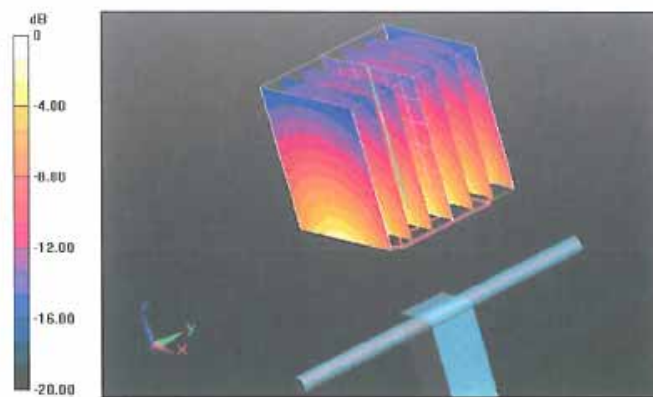

0 dB = 12.200mW/g = 21.73 dB mW/g

Impedance Measurement Plot for Head TSL

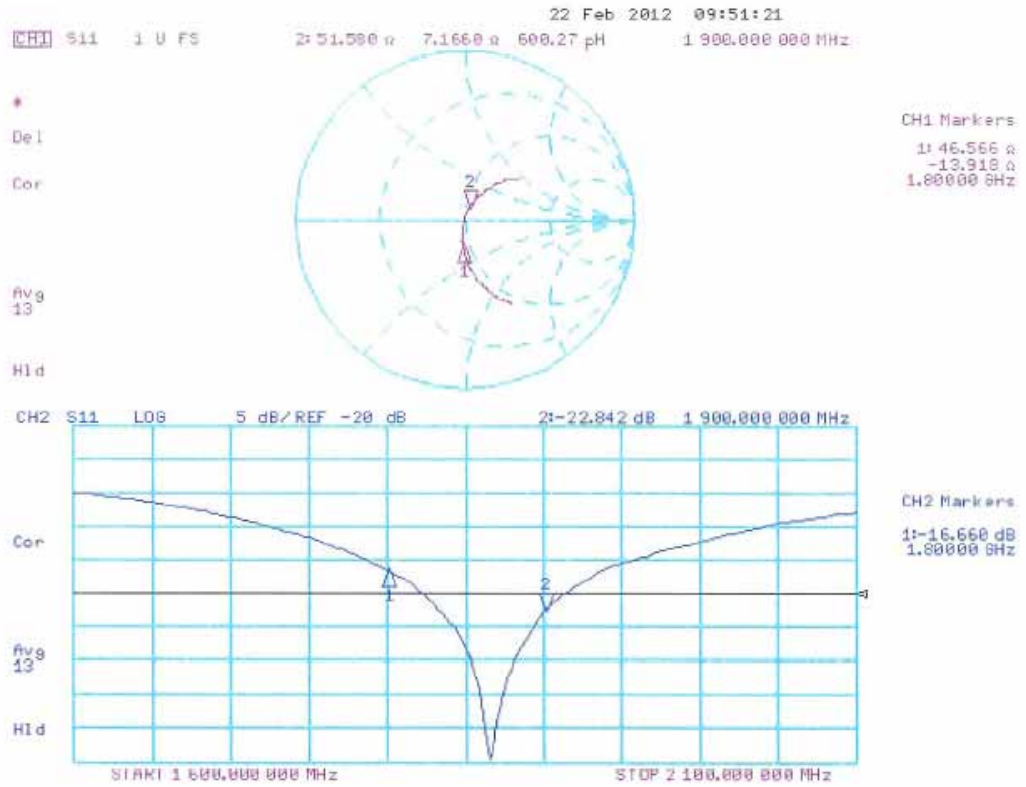

**DASY5 Validation Report for Body TSL**

Date: 22.02.2012

Test Laboratory: SPEAG, Zurich, Switzerland

**DUT: Dipole 1900 MHz; Type: D1900V2; Serial: D1900V2 - SN: 5d121**

Communication System: CW; Frequency: 1900 MHz  
 Medium parameters used:  $f = 1900$  MHz;  $\sigma = 1.56$  mho/m;  $\epsilon_r = 53$ ;  $\rho = 1000$  kg/m<sup>3</sup>  
 Phantom section: Flat Section  
 Measurement Standard: DASY5 (IEEE/IEC/ANSI C63.19-2007)

**DASY52 Configuration:**

- Probe: ES3DV3 - SN3205; ConvF(4.62, 4.62, 4.62); Calibrated: 30.12.2011
- Sensor-Surface: 3mm (Mechanical Surface Detection)
- Electronics: DAE4 Sn601; Calibrated: 04.07.2011
- Phantom: Flat Phantom 5.0 (back); Type: QD000P50AA; Serial: 1002
- DASY52 52.8.0(692); SEMCAD X 14.6.4(4989)

**Dipole Calibration for Body Tissue/Pin=250 mW, d=10mm/Zoom Scan (7x7x7)/Cube 0:**

Measurement grid: dx=5mm, dy=5mm, dz=5mm  
 Reference Value = 93.537 V/m; Power Drift = 0.0039 dB  
 Peak SAR (extrapolated) = 17.3450  
**SAR(1 g) = 9.84 mW/g; SAR(10 g) = 5.15 mW/g**  
 Maximum value of SAR (measured) = 12.473 mW/g

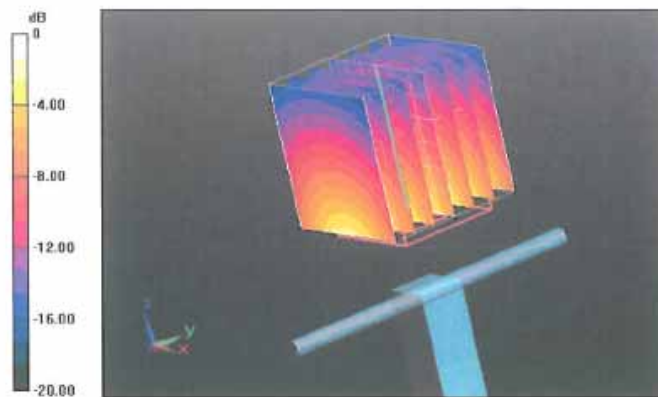

0 dB = 12.470mW/g = 21.92 dB mW/g

# Impedance Measurement Plot for Body TSL

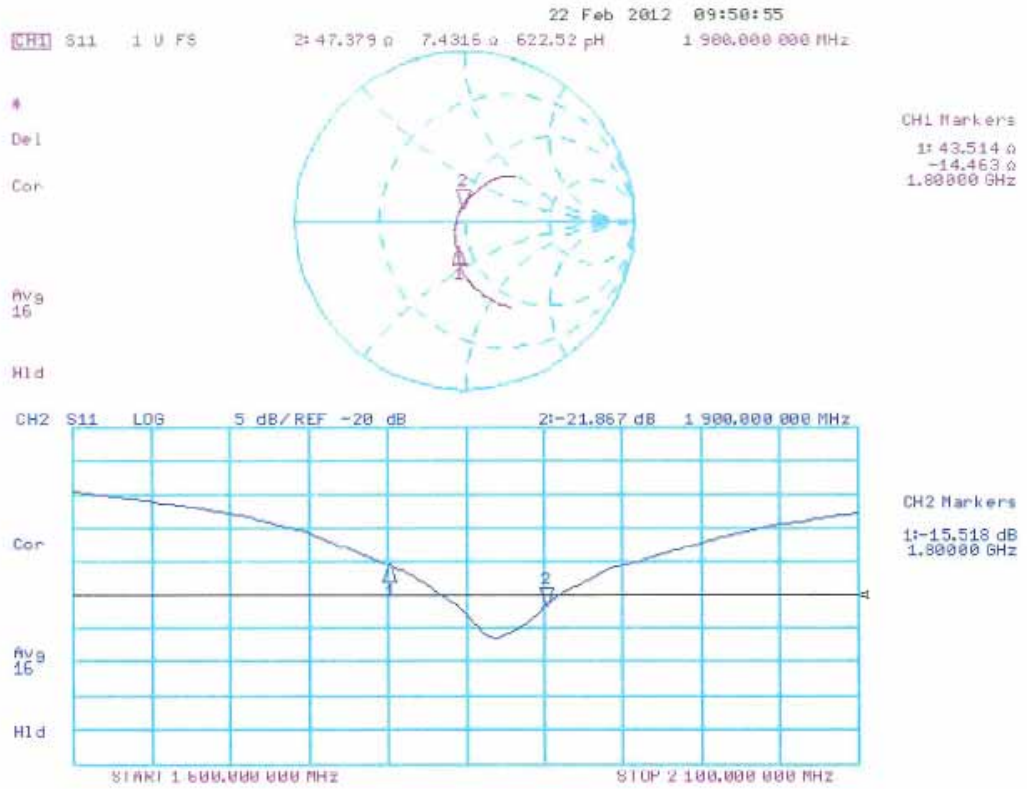

**Calibration Laboratory of  
Schmid & Partner  
Engineering AG**  
Zeughausstrasse 43, 8004 Zurich, Switzerland



**S** Schweizerischer Kalibrierdienst  
**S** Service suisse d'étalonnage  
**C** Servizio svizzero di taratura  
**S** Swiss Calibration Service

Accredited by the Swiss Accreditation Service (SAS)  
The Swiss Accreditation Service is one of the signatories to the EA  
Multilateral Agreement for the recognition of calibration certificates

Accreditation No.: **SCS 108**

Client **Quietek-CN (Auden)**

Certificate No: **D2450V2-839\_Feb12**

## CALIBRATION CERTIFICATE

Object **D2450V2 - SN: 839**

Calibration procedure(s) **QA CAL-05.v8  
Calibration procedure for dipole validation kits above 700 MHz**

Calibration date: **February 23, 2012**

This calibration certificate documents the traceability to national standards, which realize the physical units of measurements (SI).  
The measurements and the uncertainties with confidence probability are given on the following pages and are part of the certificate.

All calibrations have been conducted in the closed laboratory facility: environment temperature (22 ± 3)°C and humidity < 70%.

Calibration Equipment used (M&TE critical for calibration)

Primary Standards	ID #	Cal Date (Certificate No.)	Scheduled Calibration
Power meter EPM-442A	GB37480704	05-Oct-11 (No. 217-01451)	Oct-12
Power sensor HP 8481A	US37292783	05-Oct-11 (No. 217-01451)	Oct-12
Reference 20 dB Attenuator	SN: 5086 (20g)	29-Mar-11 (No. 217-01368)	Apr-12
Type N mismatch combination	SN: 5017.2 / 06327	29-Mar-11 (No. 217-01371)	Apr-12
Reference Probe ES3DV3	SN: 3205	30-Dec-11 (No. ES3-3205_Dec11)	Dec-12
DAE4	SN: 601	04-Jul-11 (No. DAE4-601_Jul11)	Jul-12
Secondary Standards	ID #	Check Date (in house)	Scheduled Check
Power sensor HP 8481A	MY41092317	18-Oct-02 (in house check Oct-11)	In house check: Oct-13
RF generator R&S SMT-06	100005	04-Aug-99 (in house check Oct-11)	In house check: Oct-13
Network Analyzer HP 8753E	US37390585 S4206	18-Oct-01 (in house check Oct-11)	In house check: Oct-12

Calibrated by:	Name <b>Israa El-Naouq</b>	Function <b>Laboratory Technician</b>	Signature 
Approved by:	Name <b>Katja Pokovic</b>	Function <b>Technical Manager</b>	

Issued: February 23, 2012

This calibration certificate shall not be reproduced except in full without written approval of the laboratory.



**Calibration Laboratory of  
Schmid & Partner  
Engineering AG**  
Zeughausstrasse 43, 8004 Zurich, Switzerland



**S** Schweizerischer Kalibrierdienst  
**C** Service suisse d'étalonnage  
**S** Servizio svizzero di taratura  
**S** Swiss Calibration Service

Accredited by the Swiss Accreditation Service (SAS)  
The Swiss Accreditation Service is one of the signatories to the EA  
Multilateral Agreement for the recognition of calibration certificates

Accreditation No.: **SCS 108**

**Glossary:**

TSL	tissue simulating liquid
ConvF	sensitivity in TSL / NORM x,y,z
N/A	not applicable or not measured

**Calibration is Performed According to the Following Standards:**

- a) IEEE Std 1528-2003, "IEEE Recommended Practice for Determining the Peak Spatial-Averaged Specific Absorption Rate (SAR) in the Human Head from Wireless Communications Devices: Measurement Techniques", December 2003
- b) IEC 62209-1, "Procedure to measure the Specific Absorption Rate (SAR) for hand-held devices used in close proximity to the ear (frequency range of 300 MHz to 3 GHz)", February 2005
- c) Federal Communications Commission Office of Engineering & Technology (FCC OET), "Evaluating Compliance with FCC Guidelines for Human Exposure to Radiofrequency Electromagnetic Fields; Additional Information for Evaluating Compliance of Mobile and Portable Devices with FCC Limits for Human Exposure to Radiofrequency Emissions", Supplement C (Edition 01-01) to Bulletin 65

**Additional Documentation:**

- d) DASY4/5 System Handbook

**Methods Applied and Interpretation of Parameters:**

- *Measurement Conditions:* Further details are available from the Validation Report at the end of the certificate. All figures stated in the certificate are valid at the frequency indicated.
- *Antenna Parameters with TSL:* The dipole is mounted with the spacer to position its feed point exactly below the center marking of the flat phantom section, with the arms oriented parallel to the body axis.
- *Feed Point Impedance and Return Loss:* These parameters are measured with the dipole positioned under the liquid filled phantom. The impedance stated is transformed from the measurement at the SMA connector to the feed point. The Return Loss ensures low reflected power. No uncertainty required.
- *Electrical Delay:* One-way delay between the SMA connector and the antenna feed point. No uncertainty required.
- *SAR measured:* SAR measured at the stated antenna input power.
- *SAR normalized:* SAR as measured, normalized to an input power of 1 W at the antenna connector.
- *SAR for nominal TSL parameters:* The measured TSL parameters are used to calculate the nominal SAR result.

**Measurement Conditions**

DASY system configuration, as far as not given on page 1.

DASY Version	DASY5	V52.8.0
Extrapolation	Advanced Extrapolation	
Phantom	Modular Flat Phantom	
Distance Dipole Center - TSL	10 mm	with Spacer
Zoom Scan Resolution	dx, dy, dz = 5 mm	
Frequency	2450 MHz ± 1 MHz	

**Head TSL parameters**

The following parameters and calculations were applied.

	Temperature	Permittivity	Conductivity
Nominal Head TSL parameters	22.0 °C	39.2	1.80 mho/m
Measured Head TSL parameters	(22.0 ± 0.2) °C	38.9 ± 6 %	1.86 mho/m ± 6 %
Head TSL temperature change during test	< 0.5 °C	----	----

**SAR result with Head TSL**

SAR averaged over 1 cm <sup>3</sup> (1 g) of Head TSL	Condition	
SAR measured	250 mW input power	13.2 mW / g
SAR for nominal Head TSL parameters	normalized to 1W	<b>51.9 mW / g ± 17.0 % (k=2)</b>

SAR averaged over 10 cm <sup>3</sup> (10 g) of Head TSL	condition	
SAR measured	250 mW input power	6.09 mW / g
SAR for nominal Head TSL parameters	normalized to 1W	<b>24.1 mW / g ± 16.5 % (k=2)</b>

**Body TSL parameters**

The following parameters and calculations were applied.

	Temperature	Permittivity	Conductivity
Nominal Body TSL parameters	22.0 °C	52.7	1.95 mho/m
Measured Body TSL parameters	(22.0 ± 0.2) °C	52.3 ± 6 %	2.02 mho/m ± 6 %
Body TSL temperature change during test	< 0.5 °C	----	----

**SAR result with Body TSL**

SAR averaged over 1 cm <sup>3</sup> (1 g) of Body TSL	Condition	
SAR measured	250 mW input power	12.4 mW / g
SAR for nominal Body TSL parameters	normalized to 1W	<b>48.7 mW / g ± 17.0 % (k=2)</b>

SAR averaged over 10 cm <sup>3</sup> (10 g) of Body TSL	condition	
SAR measured	250 mW input power	5.76 mW / g
SAR for nominal Body TSL parameters	normalized to 1W	<b>22.8 mW / g ± 16.5 % (k=2)</b>

**Appendix**

**Antenna Parameters with Head TSL**

Impedance, transformed to feed point	55.7 $\Omega$ - 1.0 j $\Omega$
Return Loss	- 25.2 dB

**Antenna Parameters with Body TSL**

Impedance, transformed to feed point	52.1 $\Omega$ + 1.0 j $\Omega$
Return Loss	- 32.9 dB

**General Antenna Parameters and Design**

Electrical Delay (one direction)	1.160 ns
----------------------------------	----------

After long term use with 100W radiated power, only a slight warming of the dipole near the feedpoint can be measured.

The dipole is made of standard semirigid coaxial cable. The center conductor of the feeding line is directly connected to the second arm of the dipole. The antenna is therefore short-circuited for DC-signals. On some of the dipoles, small end caps are added to the dipole arms in order to improve matching when loaded according to the position as explained in the "Measurement Conditions" paragraph. The SAR data are not affected by this change. The overall dipole length is still according to the Standard.

No excessive force must be applied to the dipole arms, because they might bend or the soldered connections near the feedpoint may be damaged.

**Additional EUT Data**

Manufactured by	SPEAG
Manufactured on	July 20, 2009

## DASY5 Validation Report for Head TSL

Date: 23.02.2012

Test Laboratory: SPEAG, Zurich, Switzerland

**DUT: Dipole 2450 MHz; Type: D2450V2; Serial: D2450V2 - SN: 839**

Communication System: CW; Frequency: 2450 MHz

Medium parameters used:  $f = 2450$  MHz;  $\sigma = 1.86$  mho/m;  $\epsilon_r = 38.9$ ;  $\rho = 1000$  kg/m<sup>3</sup>

Phantom section: Flat Section

Measurement Standard: DASY5 (IEEE/IEC/ANSI C63.19-2007)

DASY52 Configuration:

- Probe: ES3DV3 - SN3205; ConvF(4.45, 4.45, 4.45); Calibrated: 30.12.2011
- Sensor-Surface: 3mm (Mechanical Surface Detection)
- Electronics: DAE4 Sn601; Calibrated: 04.07.2011
- Phantom: Flat Phantom 5.0 (front); Type: QD000P50AA; Serial: 1001
- DASY52 52.8.0(692); SEMCAD X 14.6.4(4989)

### Dipole Calibration for Head Tissue/Pin=250 mW, d=10mm/Zoom Scan (7x7x7)/Cube 0:

Measurement grid:  $dx=5$ mm,  $dy=5$ mm,  $dz=5$ mm

Reference Value = 98.155 V/m; Power Drift = 0.08 dB

Peak SAR (extrapolated) = 27.8700

**SAR(1 g) = 13.2 mW/g; SAR(10 g) = 6.09 mW/g**

Maximum value of SAR (measured) = 16.839 mW/g

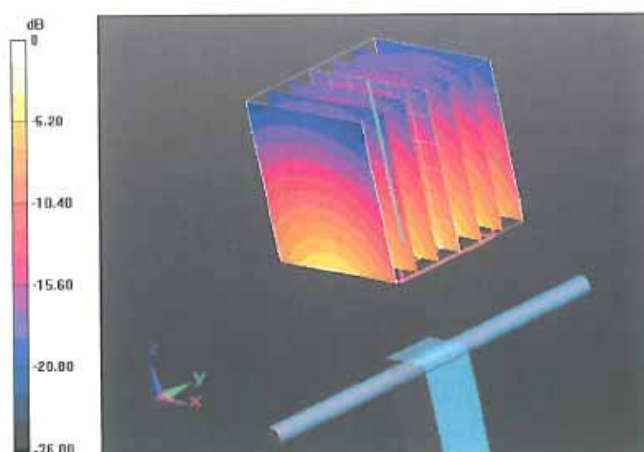

0 dB = 16.840mW/g = 24.53 dB mW/g

Impedance Measurement Plot for Head TSL

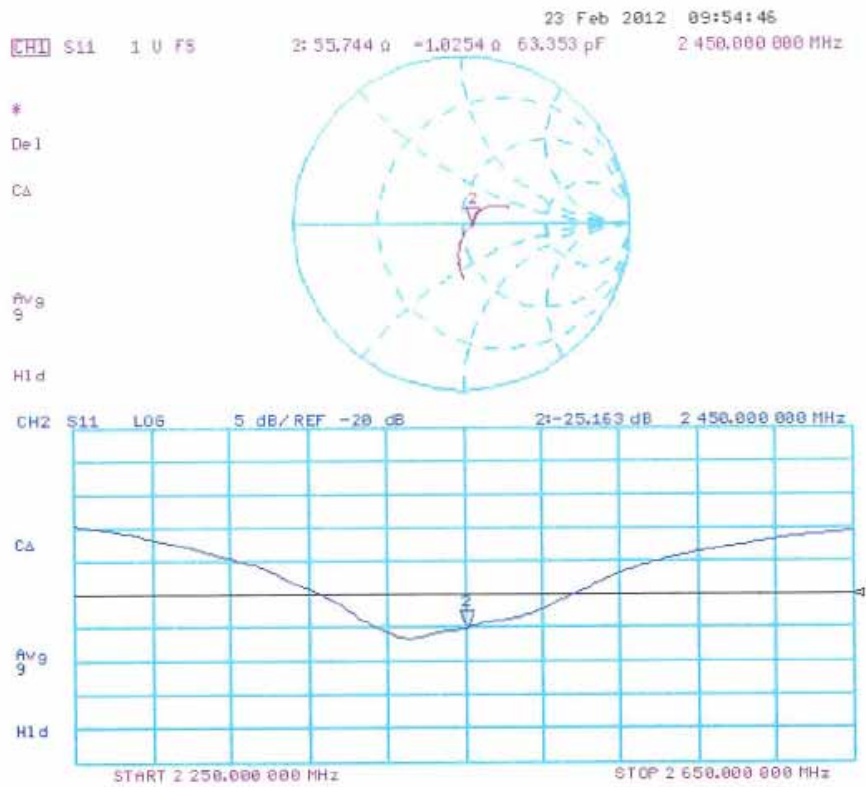

## DASY5 Validation Report for Body TSL

Date: 23.02.2012

Test Laboratory: SPEAG, Zurich, Switzerland

**DUT: Dipole 2450 MHz; Type: D2450V2; Serial: D2450V2 - SN: 839**

Communication System: CW; Frequency: 2450 MHz

Medium parameters used:  $f = 2450$  MHz;  $\sigma = 2.02$  mho/m;  $\epsilon_r = 52.3$ ;  $\rho = 1000$  kg/m<sup>3</sup>

Phantom section: Flat Section

Measurement Standard: DASY5 (IEEE/IEC/ANSI C63.19-2007)

DASY52 Configuration:

- Probe: ES3DV3 - SN3205; ConvF(4.26, 4.26, 4.26); Calibrated: 30.12.2011
- Sensor-Surface: 3mm (Mechanical Surface Detection)
- Electronics: DAE4 Sn601; Calibrated: 04.07.2011
- Phantom: Flat Phantom 5.0 (back); Type: QD000P50AA; Serial: 1002
- DASY52 52.8.0(692); SEMCAD X 14.6.4(4989)

### Dipole Calibration for Body Tissue/Pin=250 mW, d=10mm/Zoom Scan (7x7x7)/Cube 0:

Measurement grid: dx=5mm, dy=5mm, dz=5mm

Reference Value = 93.056 V/m; Power Drift = 0.0053 dB

Peak SAR (extrapolated) = 25.2250

**SAR(1 g) = 12.4 mW/g; SAR(10 g) = 5.76 mW/g**

Maximum value of SAR (measured) – 16.258 mW/g

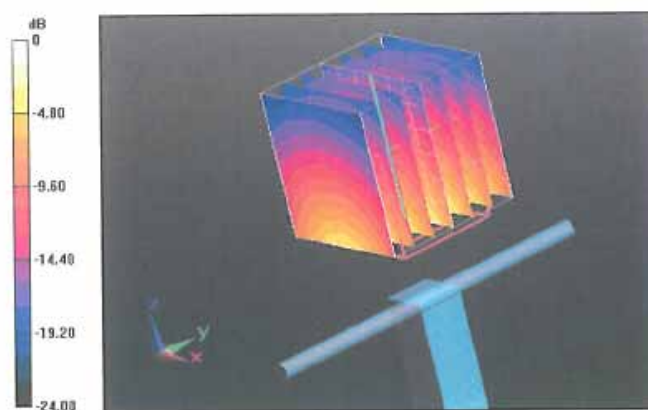

Impedance Measurement Plot for Body TSL

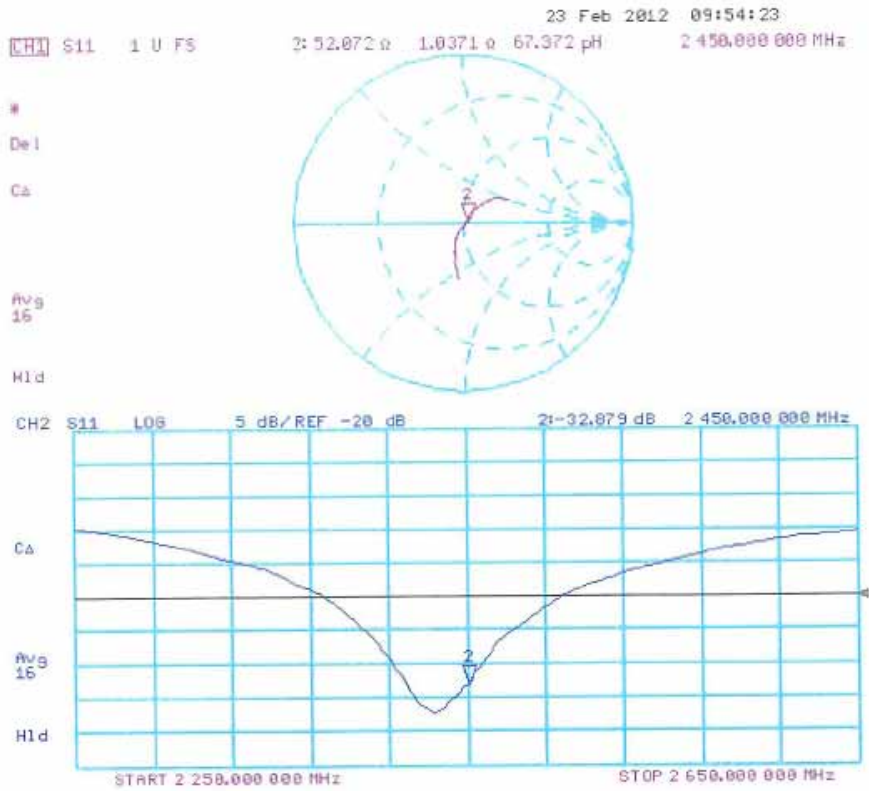

**Calibration Laboratory of  
Schmid & Partner  
Engineering AG**  
Zeughausstrasse 43, 8004 Zurich, Switzerland



**S** Schweizerischer Kalibrierdienst  
**C** Service suisse d'étalonnage  
**S** Servizio svizzero di taratura  
**S** Swiss Calibration Service

Accredited by the Swiss Accreditation Service (SAS)  
The Swiss Accreditation Service is one of the signatories to the EA  
Multilateral Agreement for the recognition of calibration certificates

Accreditation No.: **SCS 108**

Client **Quietek-CN (Auden)**

Certificate No: **D5GHzV2-1078\_Feb12**

## CALIBRATION CERTIFICATE

Object **D5GHzV2 - SN: 1078**

Calibration procedure(s) **QA CAL-22.v1  
Calibration procedure for dipole validation kits between 3-6 GHz**

Calibration date: **February 21, 2012**

This calibration certificate documents the traceability to national standards, which realize the physical units of measurements (SI).  
The measurements and the uncertainties with confidence probability are given on the following pages and are part of the certificate.

All calibrations have been conducted in the closed laboratory facility: environment temperature (22 ± 3)°C and humidity < 70%.

Calibration Equipment used (M&TE critical for calibration)

Primary Standards	ID #	Cal Date (Certificate No.)	Scheduled Calibration
Power meter EPM-442A	GB37480704	05-Oct-11 (No. 217-01451)	Oct-12
Power sensor HP 8481A	US37292783	05-Oct-11 (No. 217-01451)	Oct-12
Reference 20 dB Attenuator	SN: 5086 (20g)	29-Mar-11 (No. 217-01368)	Apr-12
Type-N mismatch combination	SN: 5047.2 / 06327	29 Mar 11 (No. 217 01371)	Apr-12
Reference Probe EX3DV4	SN: 3503	30-Dec-11 (No. EX3-3503_Dec11)	Dec-12
DAE4	SN: 601	04-Jul-11 (No. DAE4-601_Jul11)	Jul-12

Secondary Standards	ID #	Check Date (in house)	Scheduled Check
Power sensor HP 8481A	MY41092317	18-Oct-02 (in house check Oct-11)	In house check: Oct-13
RF generator R&S SMT-06	100005	04-Aug-99 (in house check Oct-11)	In house check: Oct-13
Network Analyzer HP 8753E	US37390585 S4206	18-Oct-01 (in house check Oct-11)	In house check: Oct-12

	Name	Function	Signature
Calibrated by:	Jeton Kastrati	Laboratory Technician	
Approved by:	Katja Pokovic	Technical Manager	

Issued: February 22, 2012

This calibration certificate shall not be reproduced except in full without written approval of the laboratory.



**Calibration Laboratory of  
Schmid & Partner  
Engineering AG**  
Zeughausstrasse 43, 8004 Zurich, Switzerland



**S** Schweizerischer Kalibrierdienst  
**C** Service suisse d'étalonnage  
**S** Servizio svizzero di taratura  
**S** Swiss Calibration Service

Accredited by the Swiss Accreditation Service (SAS)  
The Swiss Accreditation Service is one of the signatories to the EA  
Multilateral Agreement for the recognition of calibration certificates

Accreditation No.: **SCS 108**

**Glossary:**

TSL	tissue simulating liquid
ConvF	sensitivity in TSL / NORM x,y,z
N/A	not applicable or not measured

**Calibration is Performed According to the Following Standards:**

- a) IEEE Std 1528-2003, "IEEE Recommended Practice for Determining the Peak Spatial-Averaged Specific Absorption Rate (SAR) in the Human Head from Wireless Communications Devices: Measurement Techniques", December 2003
- b) IEC 62209-1, "Procedure to measure the Specific Absorption Rate (SAR) for hand-held devices used in close proximity to the ear (frequency range of 300 MHz to 3 GHz)", February 2005
- c) Federal Communications Commission Office of Engineering & Technology (FCC OET), "Evaluating Compliance with FCC Guidelines for Human Exposure to Radiofrequency Electromagnetic Fields; Additional Information for Evaluating Compliance of Mobile and Portable Devices with FCC Limits for Human Exposure to Radiofrequency Emissions", Supplement C (Edition 01-01) to Bulletin 65

**Additional Documentation:**

- d) DASY4/5 System Handbook

**Methods Applied and Interpretation of Parameters:**

- *Measurement Conditions:* Further details are available from the Validation Report at the end of the certificate. All figures stated in the certificate are valid at the frequency indicated.
- *Antenna Parameters with TSL:* The dipole is mounted with the spacer to position its feed point exactly below the center marking of the flat phantom section, with the arms oriented parallel to the body axis.
- *Feed Point Impedance and Return Loss:* These parameters are measured with the dipole positioned under the liquid filled phantom. The impedance stated is transformed from the measurement at the SMA connector to the feed point. The Return Loss ensures low reflected power. No uncertainty required.
- *Electrical Delay:* One-way delay between the SMA connector and the antenna feed point. No uncertainty required.
- *SAR measured:* SAR measured at the stated antenna input power.
- *SAR normalized:* SAR as measured, normalized to an input power of 1 W at the antenna connector.
- *SAR for nominal TSL parameters:* The measured TSL parameters are used to calculate the nominal SAR result.

**Measurement Conditions**

DASY system configuration, as far as not given on page 1.

DASY Version	DASY5	V52.8.0
Extrapolation	Advanced Extrapolation	
Phantom	Modular Flat Phantom V5.0	
Distance Dipole Center - TSL	10 mm	with Spacer
Zoom Scan Resolution	dx, dy = 4.0 mm, dz = 1.4 mm	Graded Ratio = 1.4 (Z direction)
Frequency	5200 MHz ± 1 MHz 5500 MHz ± 1 MHz 5800 MHz ± 1 MHz	

**Head TSL parameters at 5200 MHz**

The following parameters and calculations were applied.

	Temperature	Permittivity	Conductivity
Nominal Head TSL parameters	22.0 °C	36.0	4.66 mho/m
Measured Head TSL parameters	(22.0 ± 0.2) °C	35.3 ± 6 %	4.60 mho/m ± 6 %
Head TSL temperature change during test	< 0.5 °C	----	----

**SAR result with Head TSL at 5200 MHz**

SAR averaged over 1 cm <sup>3</sup> (1 g) of Head TSL	Condition	
SAR measured	100 mW input power	8.09 mW / g
SAR for nominal Head TSL parameters	normalized to 1W	<b>80.6 mW / g ± 17.0 % (k=2)</b>

SAR averaged over 10 cm <sup>3</sup> (10 g) of Head TSL	condition	
SAR measured	100 mW input power	2.32 mW / g
SAR for nominal Head TSL parameters	normalized to 1W	<b>23.1 mW / g ± 16.5 % (k=2)</b>

**Head TSL parameters at 5500 MHz**

The following parameters and calculations were applied.

	Temperature	Permittivity	Conductivity
Nominal Head TSL parameters	22.0 °C	35.6	4.96 mho/m
Measured Head TSL parameters	(22.0 ± 0.2) °C	34.9 ± 6 %	4.89 mho/m ± 6 %
Head TSL temperature change during test	< 0.5 °C	----	----

**SAR result with Head TSL at 5500 MHz**

SAR averaged over 1 cm <sup>3</sup> (1 g) of Head TSL	Condition	
SAR measured	100 mW input power	8.54 mW / g
SAR for nominal Head TSL parameters	normalized to 1W	<b>85.0 mW / g ± 17.0 % (k=2)</b>

SAR averaged over 10 cm <sup>3</sup> (10 g) of Head TSL	condition	
SAR measured	100 mW input power	2.44 mW / g
SAR for nominal Head TSL parameters	normalized to 1W	<b>24.3 mW / g ± 16.5 % (k=2)</b>

**Head TSL parameters at 5800 MHz**

The following parameters and calculations were applied.

	Temperature	Permittivity	Conductivity
Nominal Head TSL parameters	22.0 °C	35.3	5.27 mho/m
Measured Head TSL parameters	(22.0 ± 0.2) °C	34.4 ± 6 %	5.19 mho/m ± 6 %
Head TSL temperature change during test	< 0.5 °C	----	----

**SAR result with Head TSL at 5800 MHz**

SAR averaged over 1 cm <sup>3</sup> (1 g) of Head TSL	Condition	
SAR measured	100 mW input power	7.94 mW / g
SAR for nominal Head TSL parameters	normalized to 1W	<b>78.9 mW / g ± 17.0 % (k=2)</b>

SAR averaged over 10 cm <sup>3</sup> (10 g) of Head TSL	condition	
SAR measured	100 mW input power	2.27 mW / g
SAR for nominal Head TSL parameters	normalized to 1W	<b>22.5 mW / g ± 16.5 % (k=2)</b>

**Body TSL parameters at 5200 MHz**

The following parameters and calculations were applied.

	Temperature	Permittivity	Conductivity
Nominal Body TSL parameters	22.0 °C	49.0	5.30 mho/m
Measured Body TSL parameters	(22.0 ± 0.2) °C	48.6 ± 6 %	5.48 mho/m ± 6 %
Body TSL temperature change during test	< 0.5 °C	----	----

**SAR result with Body TSL at 5200 MHz**

SAR averaged over 1 cm <sup>3</sup> (1 g) of Body TSL	Condition	
SAR measured	100 mW input power	7.32 mW / g
SAR for nominal Body TSL parameters	normalized to 1W	<b>73.1 mW / g ± 18.1 % (k=2)</b>

SAR averaged over 10 cm <sup>3</sup> (10 g) of Body TSL	condition	
SAR measured	100 mW input power	2.05 mW / g
SAR for nominal Body TSL parameters	normalized to 1W	<b>20.5 mW / g ± 17.6 % (k=2)</b>

**Body TSL parameters at 5500 MHz**

The following parameters and calculations were applied.

	Temperature	Permittivity	Conductivity
Nominal Body TSL parameters	22.0 °C	48.6	5.65 mho/m
Measured Body TSL parameters	(22.0 ± 0.2) °C	48.1 ± 6 %	5.87 mho/m ± 6 %
Body TSL temperature change during test	< 0.5 °C	----	----

**SAR result with Body TSL at 5500 MHz**

SAR averaged over 1 cm <sup>3</sup> (1 g) of Body TSL	Condition	
SAR measured	100 mW input power	7.79 mW / g
SAR for nominal Body TSL parameters	normalized to 1W	<b>77.9 mW / g ± 18.1 % (k=2)</b>

SAR averaged over 10 cm <sup>3</sup> (10 g) of Body TSL	condition	
SAR measured	100 mW input power	2.16 mW / g
SAR for nominal Body TSL parameters	normalized to 1W	<b>21.6 mW / g ± 17.6 % (k=2)</b>

**Body TSL parameters at 5800 MHz**

The following parameters and calculations were applied.

	Temperature	Permittivity	Conductivity
Nominal Body TSL parameters	22.0 °C	48.2	6.00 mho/m
Measured Body TSL parameters	(22.0 ± 0.2) °C	48.2 ± 6 %	6.28 mho/m ± 6 %
Body TSL temperature change during test	< 0.5 °C	----	----

**SAR result with Body TSL at 5800 MHz**

SAR averaged over 1 cm <sup>3</sup> (1 g) of Body TSL	Condition	
SAR measured	100 mW input power	7.34 mW / g
SAR for nominal Body TSL parameters	normalized to 1W	<b>73.5 mW / g ± 18.1 % (k=2)</b>

SAR averaged over 10 cm <sup>3</sup> (10 g) of Body TSL	condition	
SAR measured	100 mW input power	2.03 mW / g
SAR for nominal Body TSL parameters	normalized to 1W	<b>20.3 mW / g ± 17.6 % (k=2)</b>

**Appendix**

**Antenna Parameters with Head TSL at 5200 MHz**

Impedance, transformed to feed point	51.5 $\Omega$ - 8.0 j $\Omega$
Return Loss	- 22.0 dB

**Antenna Parameters with Head TSL at 5500 MHz**

Impedance, transformed to feed point	52.7 $\Omega$ - 4.0 j $\Omega$
Return Loss	- 26.6 dB

**Antenna Parameters with Head TSL at 5800 MHz**

Impedance, transformed to feed point	57.7 $\Omega$ - 0.5 j $\Omega$
Return Loss	- 22.9 dB

**Antenna Parameters with Body TSL at 5200 MHz**

Impedance, transformed to feed point	52.0 $\Omega$ - 8.4 j $\Omega$
Return Loss	- 21.5 dB

**Antenna Parameters with Body TSL at 5500 MHz**

Impedance, transformed to feed point	51.7 $\Omega$ - 4.9 j $\Omega$
Return Loss	- 25.9 dB

**Antenna Parameters with Body TSL at 5800 MHz**

Impedance, transformed to feed point	55.1 $\Omega$ - 2.0 j $\Omega$
Return Loss	- 25.7 dB

**General Antenna Parameters and Design**

Electrical Delay (one direction)	1.199 ns
----------------------------------	----------

After long term use with 100W radiated power, only a slight warming of the dipole near the feedpoint can be measured.

The dipole is made of standard semirigid coaxial cable. The center conductor of the feeding line is directly connected to the second arm of the dipole. The antenna is therefore short-circuited for DC-signals. On some of the dipoles, small end caps are added to the dipole arms in order to improve matching when loaded according to the position as explained in the "Measurement Conditions" paragraph. The SAR data are not affected by this change. The overall dipole length is still according to the Standard.

No excessive force must be applied to the dipole arms, because they might bend or the soldered connections near the feedpoint may be damaged.

**Additional EUT Data**

Manufactured by	SPEAG
Manufactured on	September 26, 2008

**DASY5 Validation Report for Head TSL**

Date: 21.02.2012

Test Laboratory: SPEAG, Zurich, Switzerland

**DUT: Dipole 5GHz; Type: D5GHzV2; Serial: D5GHzV2 - SN: 1078**

Communication System: CW; Frequency: 5200 MHz, Frequency: 5500 MHz, Frequency: 5800 MHz  
 Medium parameters used:  $f = 5200$  MHz;  $\sigma = 4.6$  mho/m;  $\epsilon_r = 35.3$ ;  $\rho = 1000$  kg/m<sup>3</sup>, Medium parameters used:  $f = 5500$  MHz;  $\sigma = 4.89$  mho/m;  $\epsilon_r = 34.9$ ;  $\rho = 1000$  kg/m<sup>3</sup>, Medium parameters used:  $f = 5800$  MHz;  $\sigma = 5.19$  mho/m;  $\epsilon_r = 34.4$ ;  $\rho = 1000$  kg/m<sup>3</sup>  
 Phantom section: Flat Section  
 Measurement Standard: DASY5 (IEEE/IEC/ANSI C63.19-2007)

DASY52 Configuration:

- Probe: EX3DV4 - SN3503; ConvF(5.41, 5.41, 5.41), ConvF(4.91, 4.91, 4.91), ConvF(4.81, 4.81, 4.81); Calibrated: 30.12.2011
- Sensor-Surface: 1.4mm (Mechanical Surface Detection)
- Electronics: DAE4 Sn601; Calibrated: 04.07.2011
- Phantom: Flat Phantom 5.0 (front); Type: QD000P50AA; Serial: 1001
- DASY52 52.8.0(692); SEMCAD X 14.6.4(4989)

**Dipole Calibration for Head Tissue/Pin=100mW, dist=10mm, f=5200 MHz/Zoom Scan, dist=1.4mm (8x8x7)/Cube 0:** Measurement grid: dx=4mm, dy=4mm, dz=1.4mm  
 Reference Value = 64.753 V/m; Power Drift = 0.03 dB  
 Peak SAR (extrapolated) = 30.0660  
**SAR(1 g) = 8.09 mW/g; SAR(10 g) = 2.32 mW/g**  
 Maximum value of SAR (measured) = 18.532 mW/g

**Dipole Calibration for Head Tissue/Pin=100mW, dist=10mm, f=5500 MHz/Zoom Scan, dist=1.4mm (8x8x7)/Cube 0:** Measurement grid: dx=4mm, dy=4mm, dz=1.4mm  
 Reference Value = 65.079 V/m; Power Drift = 0.02 dB  
 Peak SAR (extrapolated) = 33.9620  
**SAR(1 g) = 8.54 mW/g; SAR(10 g) = 2.44 mW/g**  
 Maximum value of SAR (measured) = 19.991 mW/g

**Dipole Calibration for Head Tissue/Pin=100mW, dist=10mm, f=5800 MHz/Zoom Scan, dist=1.4mm (8x8x7)/Cube 0:** Measurement grid: dx=4mm, dy=4mm, dz=1.4mm  
 Reference Value = 61.472 V/m; Power Drift = 0.0053 dB  
 Peak SAR (extrapolated) = 33.1950  
**SAR(1 g) = 7.94 mW/g; SAR(10 g) = 2.27 mW/g**  
 Maximum value of SAR (measured) = 19.013 mW/g

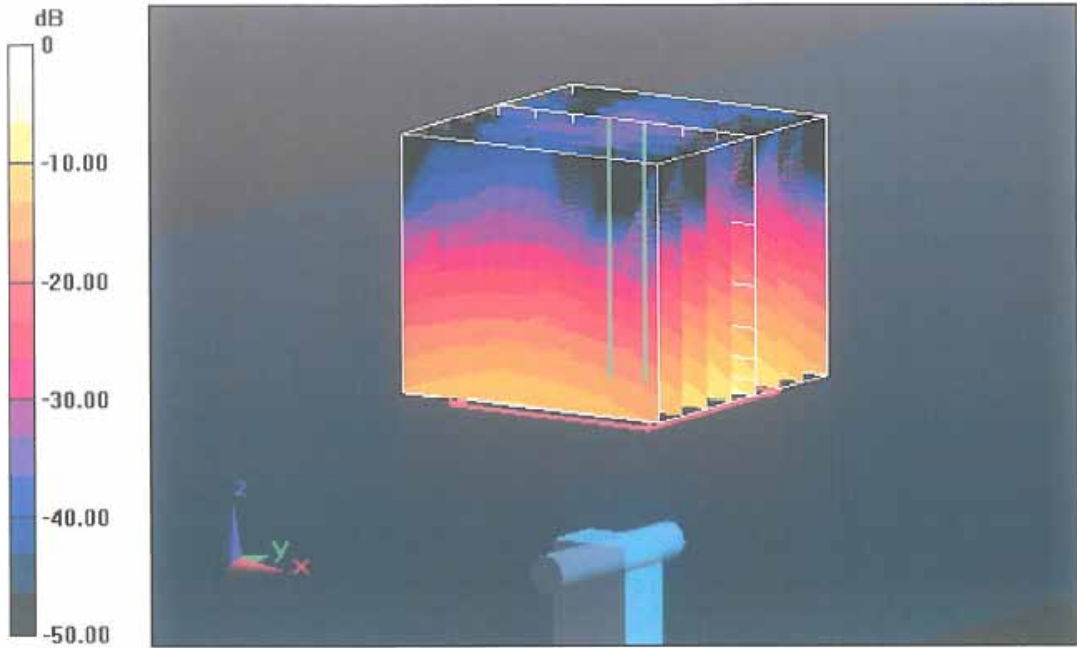

0 dB = 19.010mW/g = 25.58 dB mW/g



Impedance Measurement Plot for Head TSL

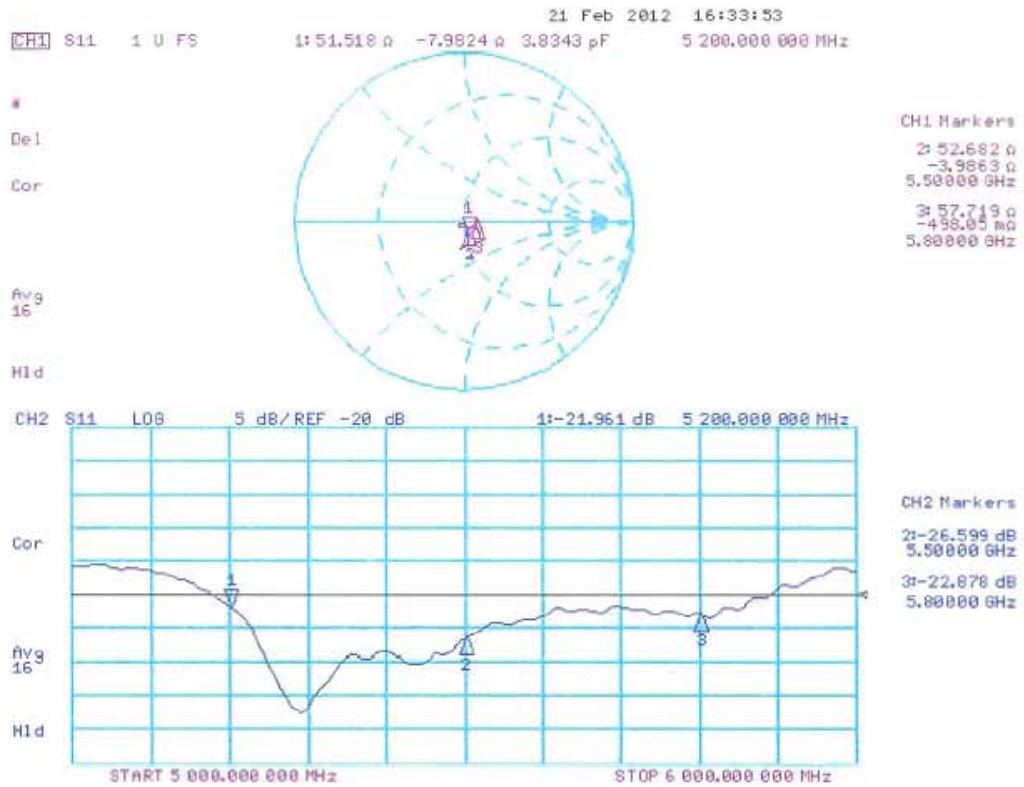

**DASY5 Validation Report for Body TSL**

Date: 20.02.2012

Test Laboratory: SPEAG, Zurich, Switzerland

**DUT: Dipole 5GHz; Type: D5GHzV2; Serial: D5GHzV2 - SN: 1078**

Communication System: CW; Frequency: 5200 MHz, Frequency: 5500 MHz, Frequency: 5800 MHz  
 Medium parameters used:  $f = 5200$  MHz;  $\sigma = 5.48$  mho/m;  $\epsilon_r = 48.6$ ;  $\rho = 1000$  kg/m<sup>3</sup>, Medium parameters used:  $f = 5500$  MHz;  $\sigma = 5.87$  mho/m;  $\epsilon_r = 48.1$ ;  $\rho = 1000$  kg/m<sup>3</sup>, Medium parameters used:  $f = 5800$  MHz;  $\sigma = 6.28$  mho/m;  $\epsilon_r = 48.2$ ;  $\rho = 1000$  kg/m<sup>3</sup>  
 Phantom section: Flat Section  
 Measurement Standard: DASY5 (IEEE/IEC/ANSI C63.19-2007)

DASY52 Configuration:

- Probe: EX3DV4 - SN3503; ConvF(4.91, 4.91, 4.91), ConvF(4.43, 4.43, 4.43), ConvF(4.38, 4.38, 4.38); Calibrated: 30.12.2011
- Sensor-Surface: 1.4mm (Mechanical Surface Detection)
- Electronics: DAE4 Sn601; Calibrated: 04.07.2011
- Phantom: Flat Phantom 5.0 (back); Type: QD000P50AA; Serial: 1002
- DASY52 52.8.0(692); SEMCAD X 14.6.4(4989)

**Dipole Calibration for Body Tissue/Pin=100mW, dist=10mm, f=5200 MHz/Zoom Scan, dist=1.4mm (8x8x7)/Cube 0:** Measurement grid: dx=4mm, dy=4mm, dz=1.4mm  
 Reference Value = 57.301 V/m; Power Drift = -0.02 dB  
 Peak SAR (extrapolated) = 28.7930  
**SAR(1 g) = 7.32 mW/g; SAR(10 g) = 2.05 mW/g**  
 Maximum value of SAR (measured) = 17.024 mW/g

**Dipole Calibration for Body Tissue/Pin=100mW, dist=10mm, f=5500 MHz/Zoom Scan, dist=1.4mm (8x8x7)/Cube 0:** Measurement grid: dx=4mm, dy=4mm, dz=1.4mm  
 Reference Value = 57.671 V/m; Power Drift = -0.02 dB  
 Peak SAR (extrapolated) = 33.4840  
**SAR(1 g) = 7.79 mW/g; SAR(10 g) = 2.16 mW/g**  
 Maximum value of SAR (measured) = 18.648 mW/g

**Dipole Calibration for Body Tissue/Pin=100mW, dist=10mm, f=5800 MHz/Zoom Scan, dist=1.4mm (8x8x7)/Cube 0:** Measurement grid: dx=4mm, dy=4mm, dz=1.4mm  
 Reference Value = 54.184 V/m; Power Drift = -0.02 dB  
 Peak SAR (extrapolated) = 34.4800  
**SAR(1 g) = 7.34 mW/g; SAR(10 g) = 2.03 mW/g**  
 Maximum value of SAR (measured) = 18.069 mW/g

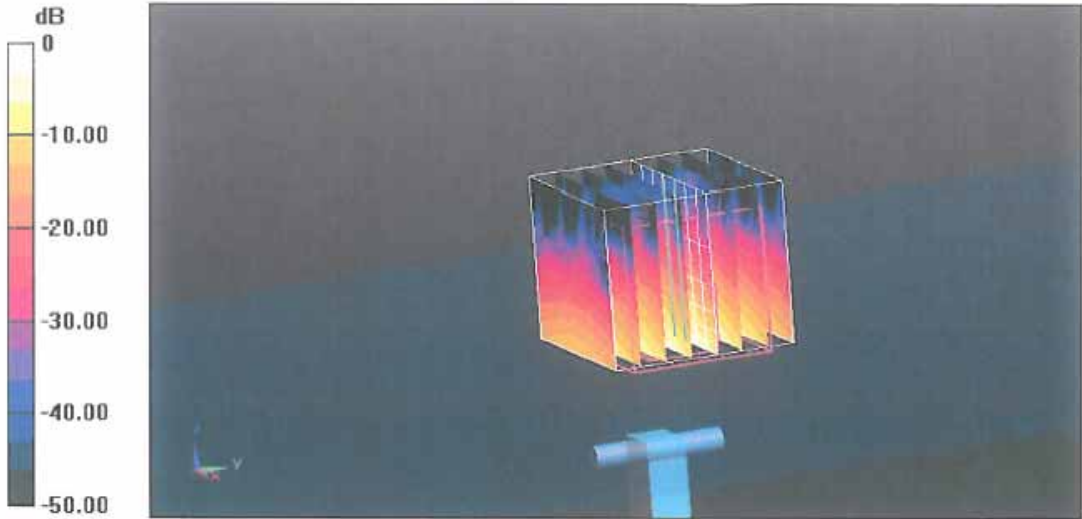

0 dB = 18.070mW/g = 25.14 dB mW/g

Impedance Measurement Plot for Body TSL

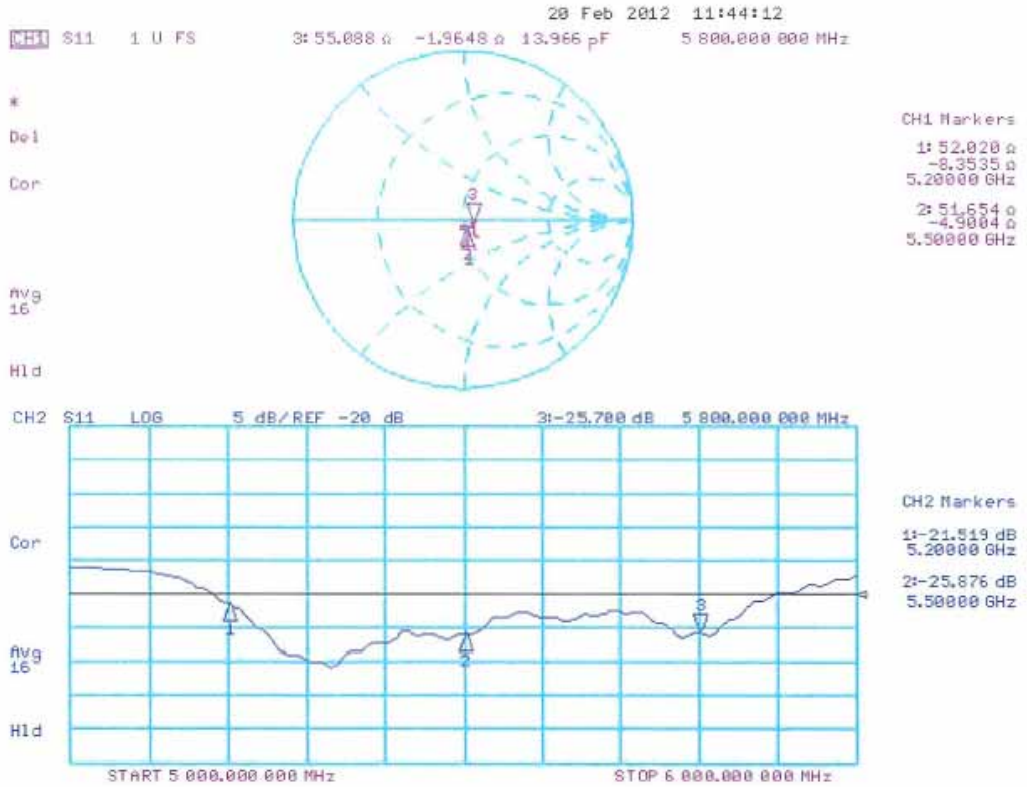

**Appendix F. DAE Calibration Data**

**Calibration Laboratory of  
Schmid & Partner  
Engineering AG**  
Zeughausstrasse 43, 8004 Zurich, Switzerland



**S** Schweizerischer Kalibrierdienst  
**C** Service suisse d'étalonnage  
**S** Servizio svizzero di taratura  
**S** Swiss Calibration Service

Accredited by the Swiss Accreditation Service (SAS)  
The Swiss Accreditation Service is one of the signatories to the EA  
Multilateral Agreement for the recognition of calibration certificates

Accreditation No.: **SCS 108**

Client **Quie Tek (Auden)**

Certificate No: **DAE4-1220\_Jan13**

**CALIBRATION CERTIFICATE**

Object **DAE4 - SD 000 D04 BJ - SN: 1220**

Calibration procedure(s) **QA CAL-06 v25  
Calibration procedure for the data acquisition electronics (DAE)**

Calibration date: **January 24, 2013**

This calibration certificate documents the traceability to national standards, which realize the physical units of measurements (SI).  
The measurements and the uncertainties with confidence probability are given on the following pages and are part of the certificate.

All calibrations have been conducted in the closed laboratory facility: environment temperature (22 ± 3)°C and humidity < 70%.

Calibration Equipment used (M&TE critical for calibration)

Primary Standards	ID #	Cal Date (Certificate No.)	Scheduled Calibration
Keithley Multimeter Type 2001	SN: 0810278	02-Oct-12 (No:12728)	Oct-13
Secondary Standards	ID #	Check Date (in house)	Scheduled Check
Auto DAE Calibration Unit	SE UWS 053 AA 1001	07-Jan-13 (in house check)	In house check: Jan-14
Calibrator Box V2.1	SE UMS 006 AA 1002	07-Jan-13 (in house check)	In house check: Jan-14

	Name	Function	Signature
Calibrated by:	R Mayoraz	Technician	<i>R Mayoraz</i>
Approved by:	Fin Bornholt	Deputy Technical Manager	<i>Fin Bornholt</i>

Issued: January 24, 2013

This calibration certificate shall not be reproduced except in full without written approval of the laboratory.

**Calibration Laboratory of  
Schmid & Partner  
Engineering AG**  
Zeughausstrasse 43, 8004 Zurich, Switzerland



**S** Schweizerischer Kalibrierdienst  
**S** Service suisse d'étalonnage  
**C** Servizio svizzero di taratura  
**S** Swiss Calibration Service

Accredited by the Swiss Accreditation Service (SAS)  
The Swiss Accreditation Service is one of the signatories to the EA  
Multilateral Agreement for the recognition of calibration certificates

Accreditation No.: **SCS 108**

## Glossary

**DAE** data acquisition electronics  
**Connector angle** information used in DASY system to align probe sensor X to the robot coordinate system.

## Methods Applied and Interpretation of Parameters

- *DC Voltage Measurement:* Calibration Factor assessed for use in DASY system by comparison with a calibrated instrument traceable to national standards. The figure given corresponds to the full scale range of the voltmeter in the respective range.
- *Connector angle:* The angle of the connector is assessed measuring the angle mechanically by a tool inserted. Uncertainty is not required.
- The following parameters as documented in the Appendix contain technical information as a result from the performance test and require no uncertainty.
  - *DC Voltage Measurement Linearity:* Verification of the Linearity at +10% and -10% of the nominal calibration voltage. Influence of offset voltage is included in this measurement.
  - *Common mode sensitivity:* Influence of a positive or negative common mode voltage on the differential measurement.
  - *Channel separation:* Influence of a voltage on the neighbor channels not subject to an input voltage.
  - *AD Converter Values with inputs shorted:* Values on the internal AD converter corresponding to zero input voltage
  - *Input Offset Measurement:* Output voltage and statistical results over a large number of zero voltage measurements.
  - *Input Offset Current:* Typical value for information; Maximum channel input offset current, not considering the input resistance.
  - *Input resistance:* Typical value for information: DAE input resistance at the connector, during internal auto-zeroing and during measurement.
  - *Low Battery Alarm Voltage:* Typical value for information. Below this voltage, a battery alarm signal is generated.
  - *Power consumption:* Typical value for information. Supply currents in various operating modes.

**DC Voltage Measurement**

A/D - Converter Resolution nominal

High Range: 1LSB = 6.1 $\mu$ V, full range = -100...+300 mV

Low Range: 1LSB = 61nV, full range = -1.....+3mV

DASY measurement parameters: Auto Zero Time: 3 sec; Measuring time: 3 sec

Calibration Factors	X	Y	Z
High Range	405.203 $\pm$ 0.02% (k=2)	404.925 $\pm$ 0.02% (k=2)	404.155 $\pm$ 0.02% (k=2)
Low Range	3.97823 $\pm$ 1.55% (k=2)	3.99494 $\pm$ 1.55% (k=2)	3.98678 $\pm$ 1.55% (k=2)

**Connector Angle**

Connector Angle to be used in DASY system	176.5 $^{\circ}$ $\pm$ 1 $^{\circ}$
---	-------------------------------------

**Appendix**

**1. DC Voltage Linearity**

High Range	Reading ( $\mu\text{V}$ )	Difference ( $\mu\text{V}$ )	Error (%)
Channel X + Input	199994.51	-0.20	-0.00
Channel X + Input	20002.32	2.74	0.01
Channel X - Input	-19999.37	2.24	-0.01
Channel Y + Input	199995.12	0.58	0.00
Channel Y + Input	19999.79	0.15	0.00
Channel Y - Input	-20001.15	0.37	-0.00
Channel Z + Input	199993.80	-0.47	-0.00
Channel Z + Input	19998.06	-1.59	-0.01
Channel Z - Input	-20003.12	-1.65	0.01

Low Range	Reading ( $\mu\text{V}$ )	Difference ( $\mu\text{V}$ )	Error (%)
Channel X + Input	2000.11	0.30	0.02
Channel X + Input	199.89	-0.29	-0.15
Channel X - Input	-199.74	-0.14	0.07
Channel Y + Input	2000.30	0.54	0.03
Channel Y + Input	200.19	0.06	0.03
Channel Y - Input	-199.81	-0.14	0.07
Channel Z + Input	1999.40	-0.47	-0.02
Channel Z + Input	199.41	-0.98	-0.49
Channel Z - Input	-200.25	-0.72	0.36

**2. Common mode sensitivity**

DASY measurement parameters: Auto Zero Time: 3 sec; Measuring time: 3 sec

	Common mode Input Voltage (mV)	High Range Average Reading ( $\mu\text{V}$ )	Low Range Average Reading ( $\mu\text{V}$ )
Channel X	200	9.11	7.73
	- 200	-8.18	-9.59
Channel Y	200	-9.61	-9.37
	- 200	8.21	8.45
Channel Z	200	12.18	11.90
	- 200	-15.16	-14.84

**3. Channel separation**

DASY measurement parameters: Auto Zero Time: 3 sec; Measuring time: 3 sec

	Input Voltage (mV)	Channel X ( $\mu\text{V}$ )	Channel Y ( $\mu\text{V}$ )	Channel Z ( $\mu\text{V}$ )
Channel X	200	-	2.08	-4.00
Channel Y	200	7.59	-	2.69
Channel Z	200	9.59	6.24	-



**4. AD-Converter Values with inputs shorted**

DASY measurement parameters: Auto Zero Time: 3 sec; Measuring time: 3 sec

	High Range (LSB)	Low Range (LSB)
Channel X	15892	15975
Channel Y	16014	16213
Channel Z	15705	16067

**5. Input Offset Measurement**

DASY measurement parameters: Auto Zero Time: 3 sec; Measuring time: 3 sec  
Input 10MΩ

	Average (μV)	min. Offset (μV)	max. Offset (μV)	Std. Deviation (μV)
Channel X	1.05	-0.80	2.18	0.45
Channel Y	-0.16	-1.22	0.92	0.45
Channel Z	-0.69	-2.22	0.60	0.48

**6. Input Offset Current**

Nominal Input circuitry offset current on all channels: <25fA

**7. Input Resistance** (Typical values for information)

	Zeroing (kOhm)	Measuring (MOhm)
Channel X	200	200
Channel Y	200	200
Channel Z	200	200

**8. Low Battery Alarm Voltage** (Typical values for information)

Typical values	Alarm Level (VDC)
Supply (+ Vcc)	+7.9
Supply (- Vcc)	-7.6

**9. Power Consumption** (Typical values for information)

Typical values	Switched off (mA)	Stand by (mA)	Transmitting (mA)
Supply (+ Vcc)	+0.01	+6	+14
Supply (- Vcc)	-0.01	-8	-9