

GOC-Q82008W V1.2

Bluetooth Module Hardware Specification

Document Type: Bluetooth Module Hardware Specification
Document Number: GOC-Q82008W V1.2
Document Version: V1.0
Release Date: 2022/09/01

Autel Intelligent Tech. Corp., Ltd

Fax:0755-86147758 TEL: 0755-86147778

Website:www.auteltech.net

Address:7th, 8th and 10th Floor, Building B1, Zhiyuan, Xueyuan Road, Xili, Nanshan, Shenzhen, 518055, China.

Be careful:

- 1. The module must use ladder steel net, and recommend ladder steel net thickness 0.16--0.20mm. The adaptability of the products is adjusted accordingly.**
- 2. Before the use of the module, bake at 60 degrees centigrade and bake for 12 hours.**

Release Record

Version Number	Release Date	Comments
V1.0	2022/09/01	Initial issue

Contents

1. Introduction.....	4
1.1 Module Block Diagram.....	4
1.2 Features	4
1.3 Application.....	5
2. Main Specification Instruction.....	6
3. Pin Diagram And Description.....	7
3.1 Pin Diagram.....	7
3.2 Pin Definition	7
3.3 PCB Layout Footprint	9
4. UART Interface	10
5. PCM Interface.....	11
6. USB Interface.....	15
7. Electrical Characteristics	16
7.1 Absolute Maximum Ratings	16
7.2 Recommended Operating Conditions	16
8. Recommended Reflow Profile.....	16
9. PCB Layout Recommendation	17
9.1 HCI UART Lines Layout Guideline	17
9.2 PCM Lines Layout Guideline	17
9.3 Power Trace Lines Layout Guideline.....	17
9.4 Ground Lines Layout Guideline.....	17
10. Module Part Number Description.....	17
11. Ordering Information	17
12. Packaging Information.....	18
12.1 Net Weight	18
12.2 Package.....	18
12.3 Storage Requirements	18
12.4 Humidity Sensitive Characteristic.....	18

1. Introduction

The GOC-Q82008W V1.2 is a single-chip flash programmable dual mode Bluetooth v5.0 device with integrated application processor, low-power audio DSP, on-chip ROM and RAM, stereo codec, battery charger, switch-mode and linear regulators, and LED drivers.

The GOC-Q82008W V1.2 on-chip ROM includes Bluetooth HCI lower and upper stack, and the audio DSP application with the end product application and user interface in external flash programmable memory.

The GOC-Q82008W V1.2 device, the 1-mic hands-free stereo speaker application (binary image and source code), IDE, and configuration tools provide a flexible and powerful platform for developing Bluetooth audio products with fast time to market.

GOC-Q82008W V1.2 can be the same with instructions of A2DP V1.3.1 AVRCP V1.6 HFP V1.7 HSP V1.2 SPP V1.2 DIDV1.3 HOGP V1.0 PXP V1.0.1 FMP V1.0 BAS V1.0 and so on, and is easy to apply the module into your own product design.

In addition, GOC-Q82008W V1.2 can help users to customize soft well based on abundance in extra soft well design.

1.1 Module Block Diagram

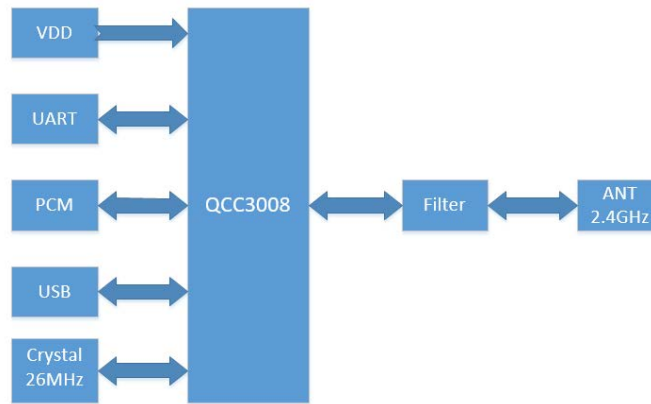

Figure 1: Module Block Diagram

1.2 Features

- Bluetooth v5.0 specification compliant
- Dual Mode Bluetooth
- Dual Mode Topology
- Link Layer Topology
- Supports Multiple BR/EDR and Bluetooth Low Energy connection scenarios
- 16 dBm (typ) RF transmit power
- -92 dBm (typ) $\pi/4$ DQPSK receiver sensitivity and -82.0 dBm (typ) 8DPSK receiver sensitivity
- Qualcomm® Bluetooth® Low Energy secure connection
- Qualcomm® cVc™ noise reduction technology Mic/ Generation
- Bluetooth Profiles
 - A2DP V1.3.1
 - AVRCP V1.6
 - HFP V1.7
 - HSP V1.2
 - SPP V1.2
 - DIDV1.3
 - HOGP V1.0

PXP V1.0.1

FMP V1.0

BAS V1.0

- Stereo audio of SBC and AAC audio codecs
- Decoders
- Qualcomm TrueWireless™ Stereo
- Use Cases
 - Concurrent A2DP and Android/iOS L APP LE connections
 - Background over-the-air software update

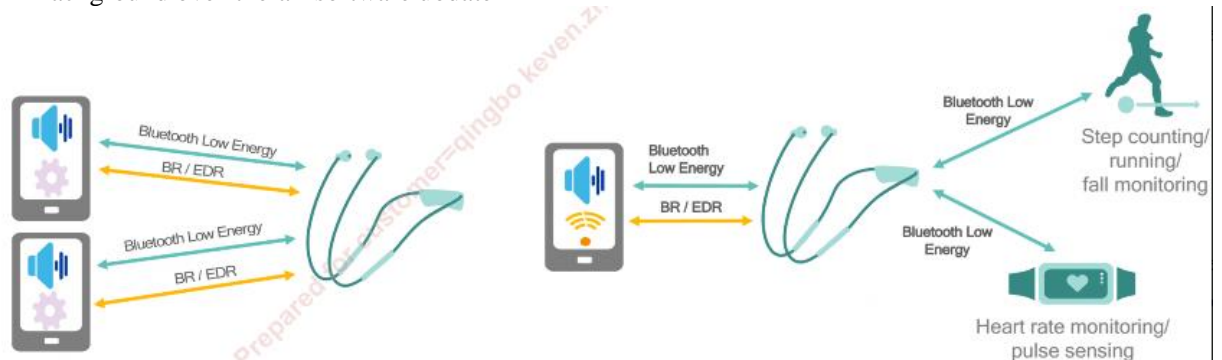

- Stereo speakers
- Speakerphones
- TVs
- Smart remote controllers
- Wired or wireless soundbars
- Wired or wireless speakers and headphones
- Wearable audio with sensors (health and well-being applications)
- Wired or wireless speakers
- Wired or wireless speakerphones
- Mono headsets for voice
- Stereo headsets
- Wired stereo headsets and headphones

1.3 Application

- Over the air Update
- Voice Prompt Updates
- LE Secure Connections
- Fully configurable EQ: 6 banks for music enhancement; 1 bank for speaker
- Serial interfaces: UART
- USB 2.0 (full-speed) interface
- Operating Voltage : VDD : 3.13 to 3.46V
- GPIO Voltage:3.30V
- Dimension: 35.75mm*14.50mm*3.00mm
- Stamp- 28 package module suitable for Surface Mounted Technology (SMT)
- Green (RoHS compliant and noantimony or halogenated flame retardants)

2. Main Specification Instruction

Production	Bluetooth Module
Type	GOC-Q82008W V1.2
Standard	Bluetooth V5.0
IC	QCC3008
Frequency Range	2402~2480MHz
Modulation Method	GFSK, $\pi/4$ -DQPSK,8DPSK
Max Speed For Transfer	Asynchronous: 723.2Kbps/57.6Kbps Synchronous: 433.9Kbps/433.9Kbps
Hop	1600hops/sec, 1MHz Channel Space
Output Impedance	50 Ohms
Crystal Frequency	26MHz
Outer Interface	UART, SPI,PCM,USB,Microphone
Apply To Bluetooth Instructions	A2DP V1.3.1 AVRCP V1.6 HFP V1.7 HSP V1.2 SPP V1.2 DIDV1.3 HOGP V1.0 PXP V1.0.1 FMP V1.0 BAS V1.0
Receiving Sensitivity	-89dBm
Transmit Power	16dBm
Dimension	35.75mm*14.50mm*3.00mm
Power Voltage	3.30 V Supply Voltage Typically
Working Current	90--100mA
Standby Current	10--15mA
Storage Temperature	-40 ℃ to +105 ℃
Temperature Range	-40 ℃ to +85 ℃
Humidity Range	10%~90% Non-Condensing
Antenna Type	Ceramic Antenna
Antenna Gain	0.5dBi

Table 1: Main Specifications

3. Pin Diagram And Description

3.1 Pin Diagram

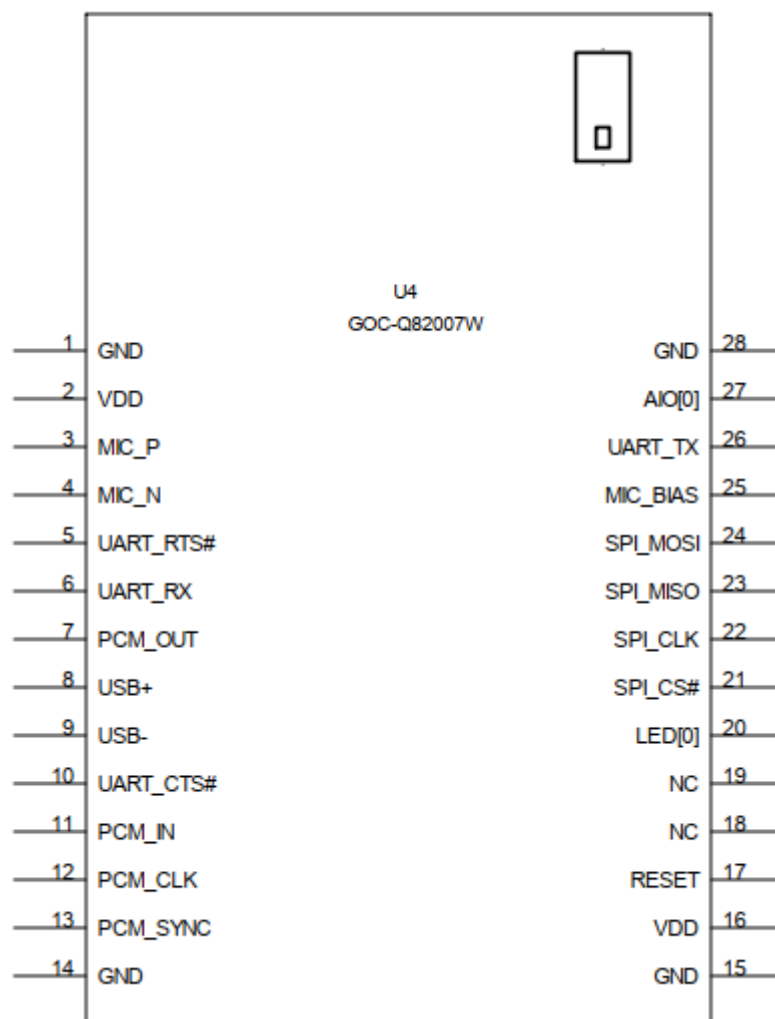

Figure 2: Pin Diagram

3.2 Pin Definition

Pin	Pin Name	Pad Type	Description
1	GND	GND	Ground connections
2	VDD	Power	3.3V Supply voltage
3	MIC_P	Analog in	Microphone input positive
4	MIC_N	Analog in	Microphone input negative
5	UART_RTS#	Bidirectional with strong pull-up	UART request to send, active low

6	UART_RX	Bidirectional with strong pull-up	UART data input
7	PCM_OUT	Bidirectional with weak pull-down	Synchronous data output
8	USB_D+	Bidirectional	USB data plus with selectable internal 1.5 kΩ pull-up resistor
9	USB_D-	Bidirectional	USB data minus
10	UART_CTS#	Bidirectional with strong pull-down	UART clear to send, active low
11	PCM_IN	Bidirectional with weak pull-down	Synchronous data input
12	PCM_CLK	Bidirectional with weak pull-down	Synchronous data clock
13	PCM_SYNC	Bidirectional with weak pull-down	Synchronous data sync
14	GND	GND	Ground connections
15	GND	GND	Ground connections
16	VDD	Power	3.3V Supply voltage
17	RESET	Input with strong pull-up	Reset if high. Pull low for minimum 5 ms to cause a reset
18	NC	NC	NC
19	NC	NC	NC
20	LED[0]	Bidirectional	Open-drain output
21	SPI_CS#	Bidirectional with weak pull-down	chip select for Debug SPI, active low
22	SPI_CLK	Bidirectional with weak pull-down	Debug SPI clock
23	SPI_MISO	Bidirectional with weak pull-down	Debug SPI data output
24	SPI_MOSI	Bidirectional with weak pull-down	Debug SPI data input
25	MIC_BAIS	Analog in	Microphone bias
26	UART_TX	Bidirectional with strong pull-up	UART data output
27	AIO[0]	Bidirectional	Analog programmable input

28	GND	GND	Ground connections
----	-----	-----	--------------------

Table 2: Pin Description

3.3 PCB Layout Footprint

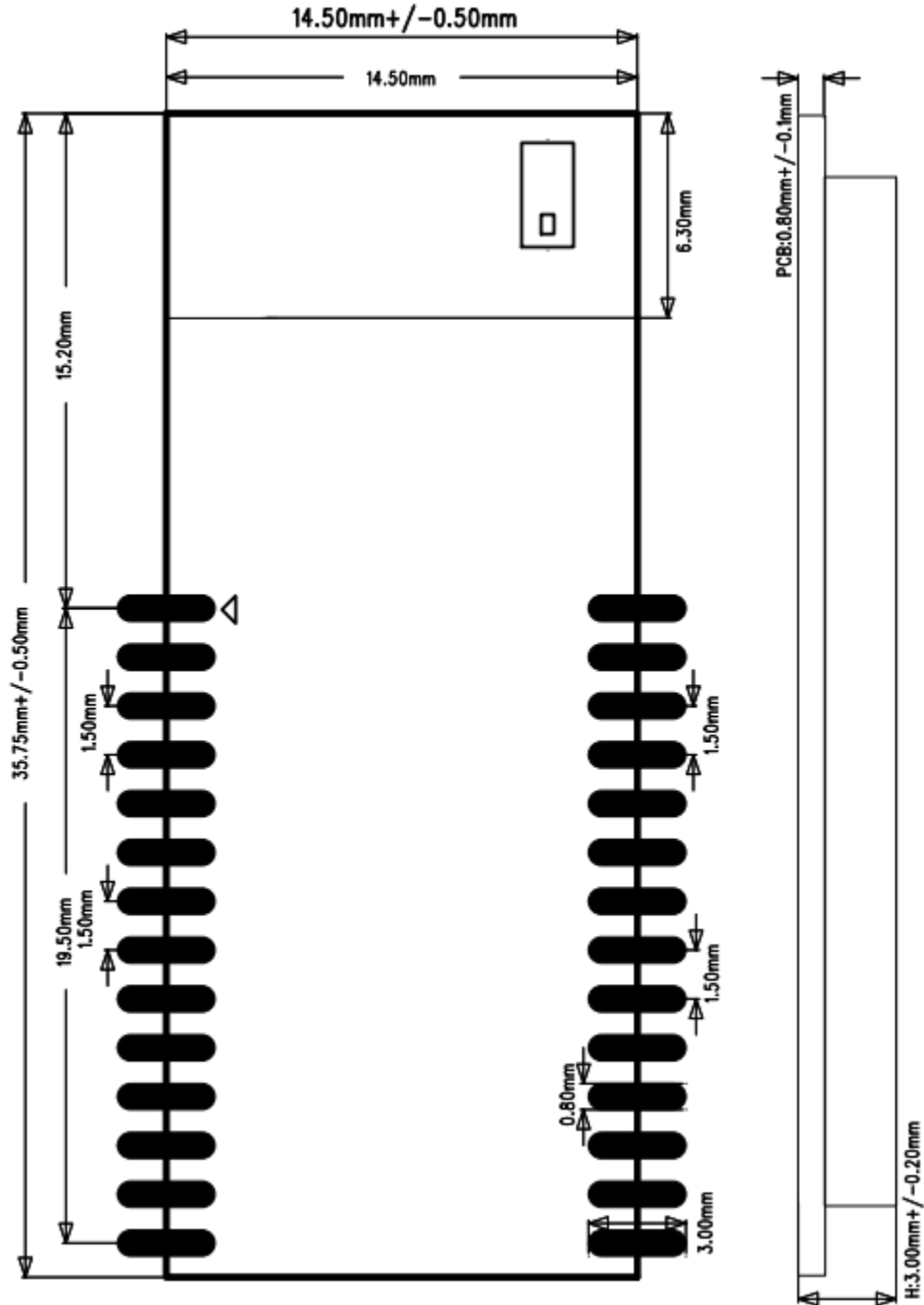

Figure 3: GOC-Q82007W PCB Layout Footprint

4. UART Interface

GOC-Q82008W V1.2 has a UART serial interface that provides a simple mechanism for communicating with other serial devices using the RS232 protocol, including for test and debug. The UART interface is multiplexed with PIOs and other functions, and hardware flow control is optional.

PS Keys for UART/PIO multiplexing

PS Key	PIO location
UART_RX	PIO[0]
UART_TX	PIO[1]
UART_RTS	PIO[8] or PIO[16]
UART_CTS	PIO[9] or PIO[17]

shows the 4 signals that implement the UART function

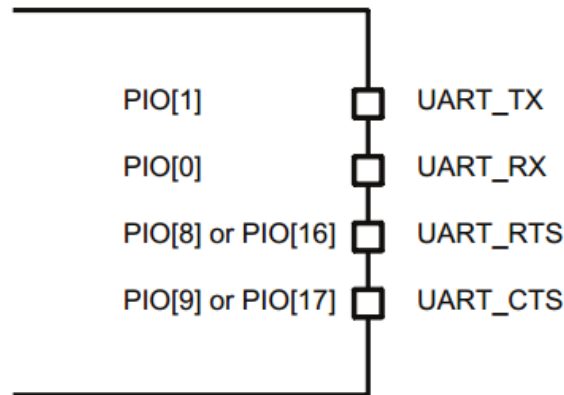

Figure 4: Universal asynchronous receiver

When GOC-Q82008W V1.2 is connected to another digital device, UART_RX and UART_TX transfer data between the 2 devices. The remaining 2 signals, UART_CTS and UART_RTS, implement optional RS232 hardware flow control where both are active low indicators.

UART configuration parameters, such as baud rate and packet format, are set using the GOC-Q82008W V1.2 firmware.

Possible UART settings

Parameter	Possible values	
Baud rate	Minimum	1200 baud ($\leq 2\%$ Error)
	Maximum	9600 baud ($\leq 1\%$ Error)
Flow control	RTS/CTS or None	
Parity	None, Odd or Even	
Number of stop bits	1 or 2	
Bits per byte	8	

Table 3: Possible UART settings

Standard baud rates

Baud rate	Error
1200	1.73%
2400	1.73%
4800	1.73%
9600	-0.82%
19200	0.45%

38400	-0.18%
57600	0.03%
76800	0.14%
115200	0.03%
230400	0.03%
460800	-0.02%
921600	0.00%
1382400	-0.01%
1843200	0.00%
2764800	0.00%
3686400	0.00%

Table 4: Standard baud rates

5. PCM Interface

The PCM Interface on the GOC-Q82008W V1.2 can connect to linear PCM Codec devices in master or slave mode. In master mode, the GOC-Q82008W V1.2 generates the PCM_CLK and PCM_SYNC signals, and in slave mode, these signals are provided by another master on the PCM interface and are inputs to the GOC-Q82008W V1.2.

The configuration of the PCM interface may be adjusted by the host through the use of vendor-specific HCI commands.

Slot Mapping

The GOC-Q82008W V1.2 supports up to three simultaneous full-duplex SCO or eSCO channels through the PCM interface. These three channels are time-multiplexed onto the single PCM interface by using a time-slotting scheme where the 8 kHz or 16 kHz audio sample interval is divided into as many as 16 slots. The number of slots is dependent on the selected interface rate of 128 kHz, 512 kHz, or 1024 kHz. The corresponding number of slots for these interface rate is 1, 2, 4, 8, and 16, respectively. Transmit and receive PCM data from an SCO channel is always mapped to the same slot. The PCM data output driver tristates its output on unused slots to allow other devices to share the same PCM interface signals. The data output driver tristates its output after the falling edge of the PCM clock during the last bit of the slot.

Frame Synchronization

The GOC-Q82008W V1.2 supports both short- and long-frame synchronization in both master and slave modes. In shortframe synchronization mode, the frame synchronization signal is an active-high pulse at the audio frame rate that is a single-bit period in width and is synchronized to the rising edge of the bit clock. The PCM slave looks for a high on the falling edge of the bit clock and expects the first bit of the first slot to start at the next rising edge of the clock. In long-frame synchronization mode, the frame synchronization signal is again an active-high pulse at the audio frame rate; however, the duration is three bit periods and the pulse starts coincident with the first bit of the first slot.

Data Formatting

The GOC-Q82008W V1.2 may be configured to generate and accept several different data formats. For conventional narrowband speech mode, the GOC-Q82008W V1.2 uses 13 of the 16 bits in each PCM frame. The location and order of these 13 bits can be configured to support various data formats on the PCM interface. The remaining three bits are ignored on the input and may be filled with 0s, 1s, a sign bit, or a programmed value on the output. The default format is 13-bit 2's complement data, left justified, and clocked MSB first.

PCM Interface Timing
Short Frame Sync, Master Mode

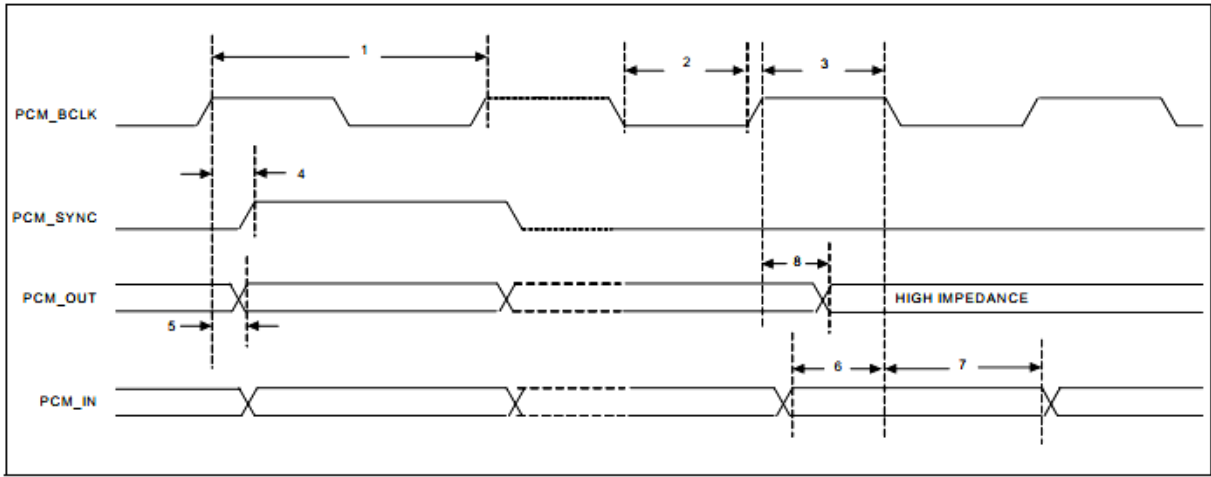

Figure 5: PCM Timing Diagram (Short Frame Sync, Master Mode)

Reference	Characteristics	Minimum	Typical	Maximum	Unit
1	PCM bit clock frequency	-	-	12	MHz
2	PCM bit clock LOW	41	-	-	ns
3	PCM bit clock HIGH	41	-	-	ns
4	PCM_SYNC delay	0	-	25	ns
5	PCM_OUT delay	0	-	25	ns
6	PCM_IN setup	8	-	-	ns
7	PCM_IN hold	8	-	-	ns
8	Delay from rising edge of PCM_BCLK during last bit period to PCM_OUT becoming high impedance	0	-	25	ns

Table 5: PCM Interface Timing Specifications (Short Frame Sync, Master Mode)

Short Frame Sync, Slave Mode

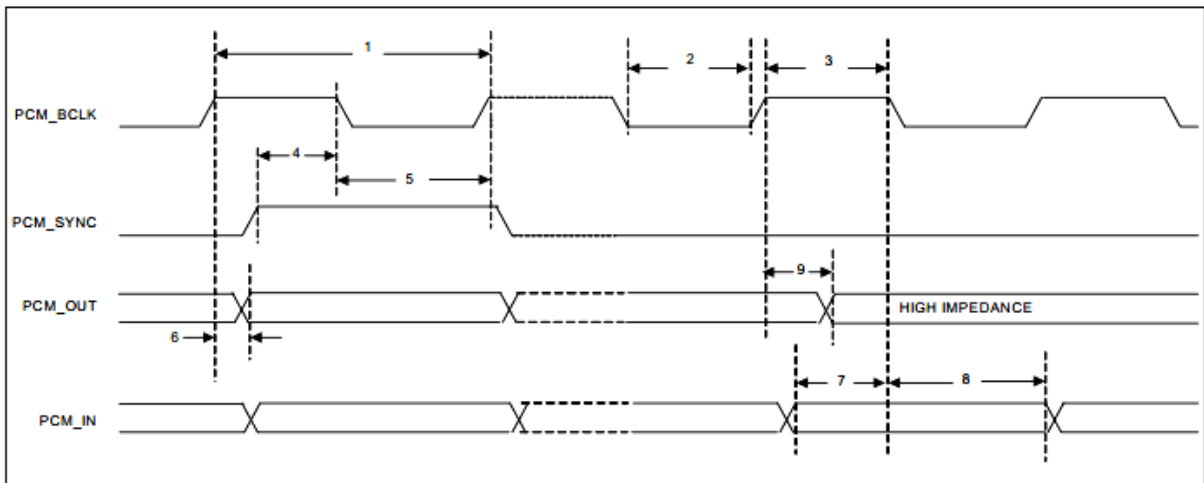

Figure 6: PCM Timing Diagram (Short Frame Sync, Slave Mode)

Reference	Characteristics	Minimum	Typical	Maximum	Unit
1	PCM bit clock frequency	-	-	12	MHz
2	PCM bit clock LOW	41	-	-	ns
3	PCM bit clock HIGH	41	-	-	ns
4	PCM_SYNC setup	8	-	-	ns
5	PCM_SYNC hold	8	-	-	ns
6	PCM_OUT delay	0	-	25	ns
7	PCM_IN setup	8	-	-	ns
8	PCM_IN hold	8	-	-	ns
9	Delay from rising edge of PCM_BCLK during last bit period to PCM_OUT becoming high impedance	0	-	25	ns

Table 6: PCM Interface Timing Specifications (Short Frame Sync, Slave Mode)

Long Frame Sync, Master Mode

Figure 7: PCM Timing Diagram (Long Frame Sync, Master Mode)

Reference	Characteristics	Minimum	Typical	Maximum	Unit
1	PCM bit clock frequency	-	-	12	MHz
2	PCM bit clock LOW	41	-	-	ns
3	PCM bit clock HIGH	41	-	-	ns
4	PCM_SYNC delay	0	-	25	ns
5	PCM_OUT delay	0	-	25	ns
6	PCM_IN setup	8	-	-	ns
7	PCM_IN hold	8	-	-	ns
8	Delay from rising edge of PCM_BCLK during last bit period to PCM_OUT becoming high impedance	0	-	25	ns

Table 7: PCM Interface Timing Specifications (Long Frame Sync, Master Mode)

Long Frame Sync, Slave Mode

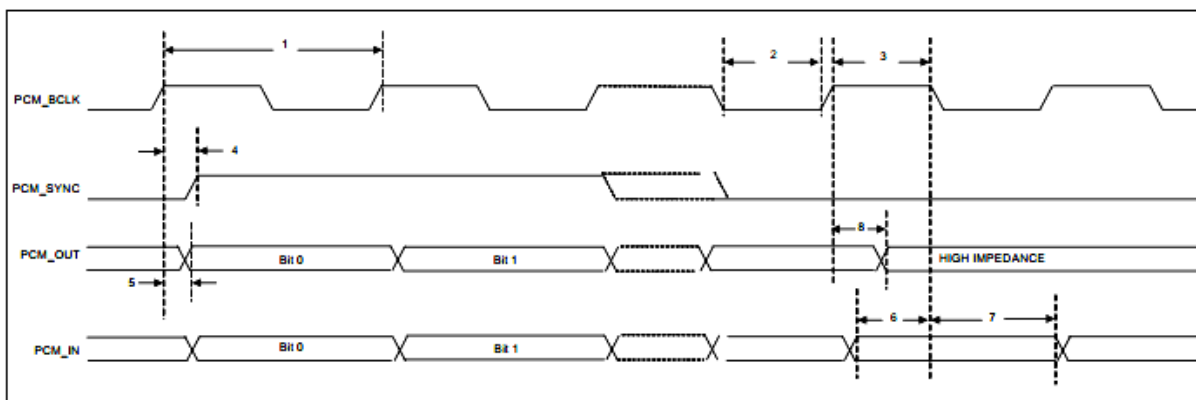
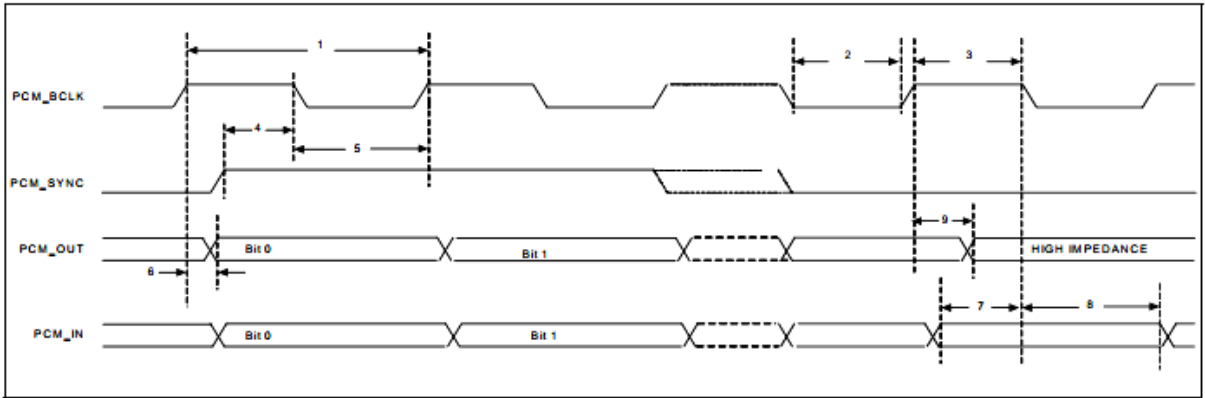

Figure 8: PCM Timing Diagram (Long Frame Sync, Slave Mode)

Reference	Characteristics	Minimum	Typical	Maximum	Unit
1	PCM bit clock frequency	-	-	12	MHz
2	PCM bit clock LOW	41	-	-	ns
3	PCM bit clock HIGH	41	-	-	ns
4	PCM_SYNC setup	8	-	-	ns
5	PCM_SYNC hold	8	-	-	ns
6	PCM_OUT delay	0	-	25	ns
7	PCM_IN setup	8	-	-	ns
8	PCM_IN hold	8	-	-	ns
9	Delay from rising edge of PCM_BCLK during last bit period to PCM_OUT becoming high impedance	0	-	25	ns

Table 8: PCM Interface Timing Specifications (Long Frame Sync, Slave Mode)

Short Frame Sync, Burst Mode

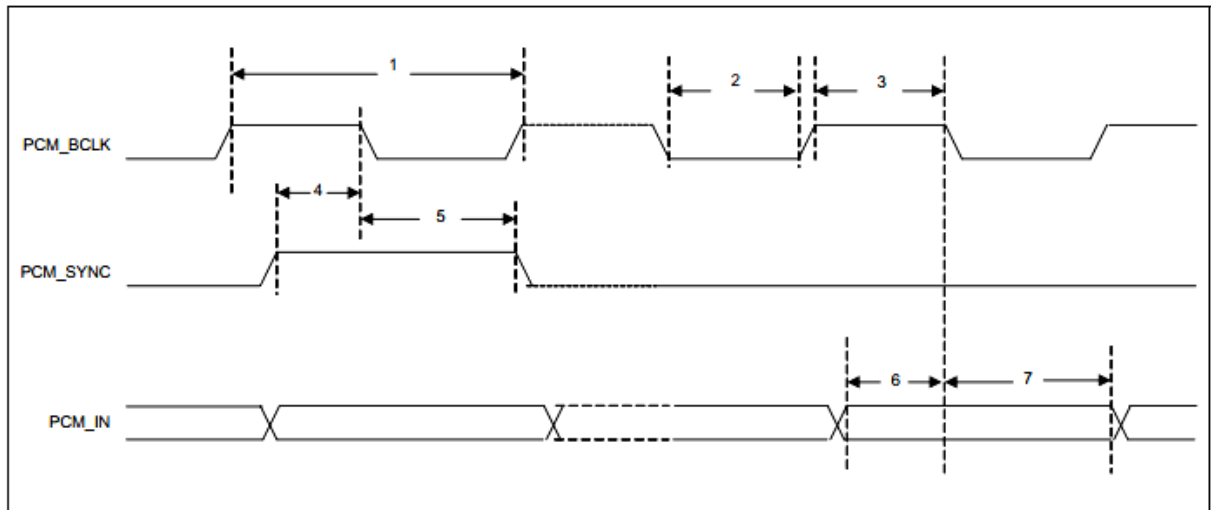

Figure 9: PCM Burst Mode Timing (Receive Only, Short Frame Sync)

Reference	Characteristics	Minimum	Typical	Maximum	Unit
1	PCM bit clock frequency	-	-	24	MHz
2	PCM bit clock LOW	20.8	-	-	ns
3	PCM bit clock HIGH	20.8	-	-	ns
4	PCM_SYNC setup	8	-	-	ns
5	PCM_SYNC hold	8	-	-	ns
6	PCM_OUT delay	8	-	-	ns
7	PCM_IN setup	8	-	-	ns
8	PCM_IN hold	8	-	-	ns

Table 9: PCM Burst Mode (Receive Only, Short Frame Sync)

Long Frame Sync, Burst Mode

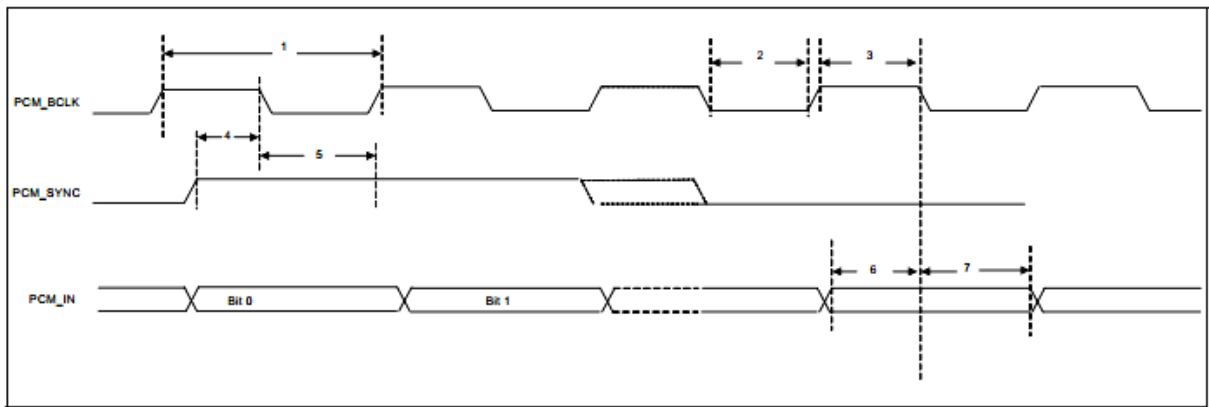

Figure 10: PCM Burst Mode Timing (Receive Only, Long Frame Sync)

Reference	Characteristics	Minimum	Typical	Maximum	Unit
1	PCM bit clock frequency	-	-	24	MHz
2	PCM bit clock LOW	20.8	-	-	ns
3	PCM bit clock HIGH	20.8	-	-	ns
4	PCM_SYNC setup	8	-	-	ns
5	PCM_SYNC hold	8	-	-	ns
6	PCM_OUT delay	8	-	-	ns
7	PCM_IN setup	8	-	-	ns
8	PCM_IN hold	8	-	-	ns

Table 10: PCM Burst Mode (Receive Only, Long Frame Sync)

6. USB Interface

GOC-Q82008W V1.2 has a full-speed (12 Mbps) USB interface for communicating with other compatible digital devices. The USB interface on GOC-Q82008W V1.2 acts as a USB peripheral, responding to requests from a master host controller.

GOC-Q82008W V1.2 contains internal USB termination resistors and requires no external resistors.

GOC-Q82008W V1.2 supports the Universal Serial Bus Specification, Revision v2.0 (USB v2.0 Specification), supports USB standard charger detection, and fully supports the USB Battery Charging Specification v1.2. For more information on how to integrate the USB interface on GOC-Q82008W V1.2, see the Bluetooth and USB Design Considerations Application Note.

As well as describing USB basics and architecture, the application note describes:

- USB Audio
- DFU

7. Electrical Characteristics

7.1 Absolute Maximum Ratings

Maximum Ratings	Min	Typical	Max
VDD	3.10V	3.30V	3.60V

Table 11: Absolute Maximum Ratings

7.2 Recommended Operating Conditions

Operating Conditions	Min	Typical	Max
Storage Temperature	-40 °C	/	+105 °C
Operating Temperature	-40 °C	20 °C	+85 °C
VDD	3.14V	3.30V	3.46V

Table 12: Recommended Operating Conditions

8. Recommended Reflow Profile

Referred to IPC/JEDEC standard.

Peak package body temperature : <math><260\text{ }^\circ\text{C}</math>.

Time of peak temperature for Pb-free assembly : 5~10sec.

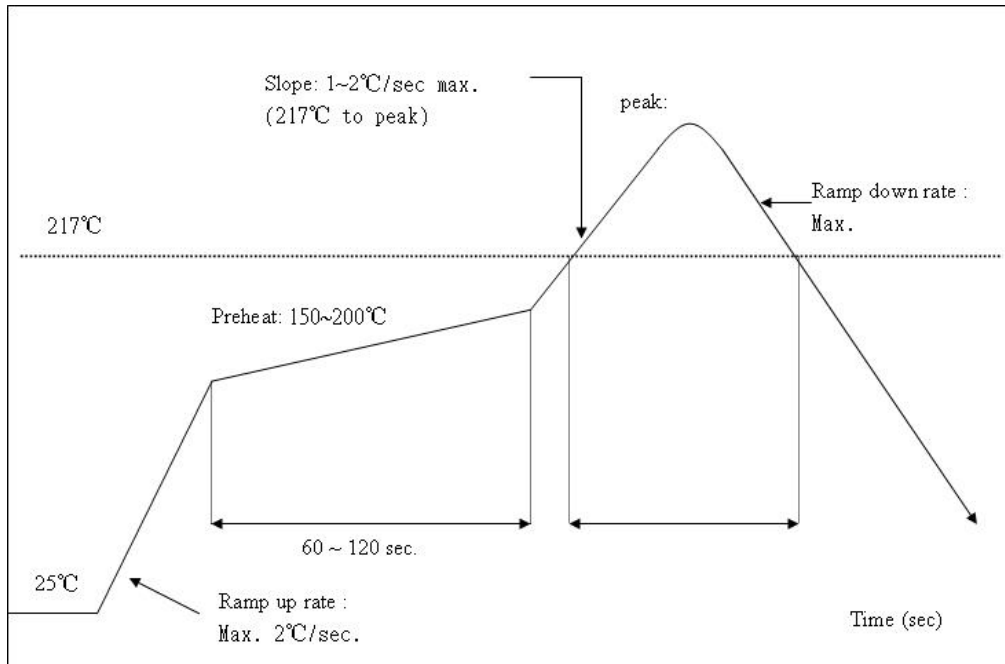

Figure11: Recommended Reflow Profile

9. PCB Layout Recommendation

9.1 HCI UART Lines Layout Guideline

The following HCI line routing must obey the following rule to prevent overshoot/undershoot, as these lines drive 4 ~ 8mA

UART_RX UART_TX UART_CTS UART_RTS

The route length of these signals be less than 15 cm and the line impedance be less than 50Ω.

9.2 PCM Lines Layout Guideline

The following HCI line routing must obey the following rule to prevent overshoot/undershoot, as these lines drive 4 mA

PCM_SYNC PCM_CLK PCM_OUT PCM_IN

The route length of these signals be less than 15 cm and the line impedance be less than 50Ω.

9.3 Power Trace Lines Layout Guideline

- VDD Trace Width: 30mil

9.4 Ground Lines Layout Guideline

- A Complete Ground in Ground Layer.
- Add Ground Through Holes to GOC-Q82008W V1.2 Module Ground Pads
- Decoupling Capacitors close to GOC-Q82008W V1.2 Module Power and Ground Pads

10. Module Part Number Description

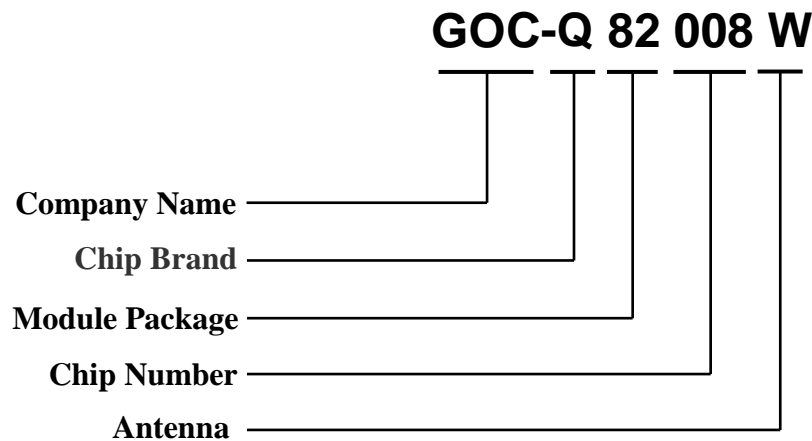

Figure12: Module Part Number Description

For a list of available options (e.g. package, packing) and orderable part numbers or for further information on any aspect of this device, please go to www.auteltech.com or contact the AUTEL Sales Office nearest to you.

11. Ordering Information

Part Number	Description	Remark
GOC-Q82008W V1.2	Bluetooth module with external PA and LNA	

Table 13: Ordering information

12. Packaging Information

12.1 Net Weight

The module net weight: $2g \pm 0.2g$

12.2 Package

TBD

12.3 Storage Requirements

1) Temperature: 22~28 °C;

2) Humidity: <70% (RH) ;

Vacuum packed and sealed in good condition to ensure 12 months of welding.

12.4 Humidity Sensitive Characteristic

1) MSL: 3 level

2) Once opened, SMT within 168 hours in the condition of temperature: 22~28 °C and humidity<60%(RH).

3) Handling, storage, and processing should follow JEDEC J-STD-020

13.Statement

FCC Statement

This equipment has been tested and found to comply with the limits for a Class B digital device, pursuant to part 15 of the FCC rules.

These limits are designed to provide reasonable protection against harmful interference in a residential installation. This equipment generates, uses and can radiate radio frequency energy and, if not installed and used in accordance with the instructions, may cause harmful interference to radio communications.

However, there is no guarantee that interference will not occur in a particular installation. If this equipment does cause harmful interference to radio or television reception, which can be determined by turning the equipment off and on, the user is encouraged to try to correct the interference by one or more of the following measures:

-Reorient or relocate the receiving antenna.

-Increase the separation between the equipment and receiver.

-Connect the equipment into an outlet on a circuit different from that to which the receiver is connected.

-Consult the dealer or an experienced radio/TV technician for help.

This equipment complies with Part 15 of the FCC Rules. Operation is subject to the following two conditions:

(1) This device may not cause harmful interference, and

(2) This device must accept any interference received, including interference that may cause undesired operation.

Any changes or modifications not expressly approved by the party responsible for compliance could void the user's authority to operate the equipment.

Please notice that if the FCC identification number is not visible when the module is installed inside another device, then the outside of the device into which the module is installed must also display a label referring to the enclosed module. This exterior label can use wording such as the following: "Contains FCC ID:WQ8-GOCQ82008W" any similar wording that expresses the same meaning may be used. This equipment complies with FCC radiation exposure limits set forth for an uncontrolled environment.

Canada Statement

This device complies with Industry Canada's licence-exempt RSSs. Operation is subject to the following two conditions:

(1) This device may not cause interference; and

(2) This device must accept any interference received, including interference that may cause undesired operation of the device.

Le présent appareil est conforme aux CNR d'Industrie Canada applicables aux appareils radio exempts de licence. L'exploitation est autorisée aux deux conditions suivantes :

(1) l'appareil ne doit pas produire de brouillage;

(2) l'utilisateur de l'appareil doit accepter tout brouillage radioélectrique subi, même si le brouillage est susceptible d'en compromettre le fonctionnement.

Please notice that if the ISED certification number is not visible when the module is installed inside another device, then the outside of the device into which the module is installed must also display a label referring to the enclosed module. This exterior label can use wording such as the following: "Contains IC:10826A-GOCQ82008W" any similar wording that expresses the same meaning may be used. l'appareil hôte doit porter une étiquette donnant le numéro de certification du module d'Industrie Canada, précédé des mots « Contient un module d'émission », du mot « IC:10826A-GOCQ82008W » ou d'une formulation similaire exprimant le même sens.