



Hermon Laboratories Ltd.
Harakevet Industrial Zone, Binyamina 30500,
Israel
Tel. +972-4-6288001
Fax. +972-4-6288277
E-mail: mail@hermonlabs.com

TEST REPORT

ACCORDING TO: FCC 47CFR part 15 subpart C § 15.247 (FHSS)

FOR:

Visonic Ltd.

**Wireless Repeater for
PowerG Communications**

Model: RP-610 PG2

This report is in conformity with ISO/ IEC 17025. The "A2LA Accredited" symbol endorsement applies only to the tests and calibrations that are listed in the scope of Hermon Laboratories accreditation. The test results relate only to the items tested. This test report shall not be reproduced in any form except in full with the written approval of Hermon Laboratories Ltd.

Table of contents

1	Applicant information	3
2	Equipment under test attributes	3
3	Manufacturer information	3
4	Test details	3
5	Tests summary	4
6	EUT description	5
6.1	General information	5
6.2	Ports and lines	5
6.3	Test configuration	5
6.4	Changes made in the EUT	5
6.5	Transmitter characteristics	6
7	Transmitter tests according to 47CFR part 15 subpart C requirements	7
7.1	20 dB bandwidth	7
7.2	Carrier frequency separation	11
7.3	Number of hopping frequencies	13
7.4	Average time of occupancy	16
7.5	Peak output power	17
7.6	Band edge radiated emissions	25
7.7	Field strength of spurious emissions	30
7.8	Antenna requirements	54
7.9	Conducted emissions	55
8	APPENDIX A Test equipment and ancillaries used for tests	58
9	APPENDIX B Measurement uncertainties	59
10	APPENDIX C Test laboratory description	60
11	APPENDIX D Specification references	60
12	APPENDIX E Test equipment correction factors	61
13	APPENDIX F Abbreviations and acronyms	72
14	APPENDIX G Applicant's declaration	73

1 Applicant information

Client name: Visonic Ltd.
Address: Habarzel street 24, Tel Aviv 69710, Israel
Telephone: +972 3645 6714
Fax: +972 3645 6788
E-mail: aelshtein@visonic.com
Contact name: Mr. Arick Elshtein

2 Equipment under test attributes

Product name: Wireless repeater for PowerG communications
Product type: Transceiver
Model(s): RP-610 PG2
Serial number: 0-100972
Hardware version: 90-203437 E-203267
Software release: JS-701608 PCA MCX-610 (REPEATER) PG2
Receipt date: 11/28/2010

3 Manufacturer information

Manufacturer name: Visonic Ltd.
Address: Habarzel street 24, Tel Aviv 69710, Israel
Telephone: +972 3645 6789
Fax: +972 3645 6788
E-Mail: aelshtein@visonic.com
Contact name: Mr. Arick Elshtein



4 Test details

Project ID: 21125
Location: Hermon Laboratories Ltd. Harakevet Industrial Zone, Binyamina 30500, Israel
Test started: 11/28/2010
Test completed: 12/28/2010
Test specification(s): FCC 47CFR part 15, subpart C, §15.247 (FHSS)

5 Tests summary

Test	Status
Transmitter characteristics	
Section 15.247(a)1, The 20 dB bandwidth	Pass
Section 15.247(a)1, Frequency separation	Pass
Section 15.247(a)1, Number of hopping frequencies	Pass
Section 15.247(a)1, Average time of occupancy	Pass
Section 15.247(b), Peak output power	Pass
Section 15.247(d), Emissions at band edges	Pass
Section 15.247(d), Radiated spurious emissions	Pass
Section 15.203, Antenna requirements	Pass
Section 15.207(a), Conducted emission	Pass
Section 15.247(i), RF exposure	Pass, the exhibit to the application of certification is provided

Testing was completed against all relevant requirements of the test standard. The results obtained indicate that the product under test complies in full with the requirements tested. The test results relate only to the items tested. Pass/ fail decision was based on nominal values.

	Name and Title	Date	Signature
Tested by:	Mrs. E. Pitt, test engineer	December 28, 2010	
Reviewed by:	Mrs. M. Cherniavsky, certification engineer	December 29, 2010	
Approved by:	Mr. M. Nikishin, EMC and radio group manager	December 30, 2010	

6 EUT description

6.1 General information

The EUT, a wireless repeater for PowerG communications, is a range extender designed to relay digital data between wireless PowerMaster-10 devices and a PowerMaster-10 Control Panel. The EUT is equipped with an integral antenna. The EUT is powered by 120 VAC/ 9 VAC adapter and is equipped with 4.8 V backup battery.

6.2 Ports and lines

Port type	Port description	Connected from	Connected to	Q-ty	Cable type	Cable length, m
Power	9 VAC power	EUT	AC/AC adapter	1	Unshielded	1.5
Power	AC power	AC/AC adapter	AC mains	1	NA	NA

6.3 Test configuration

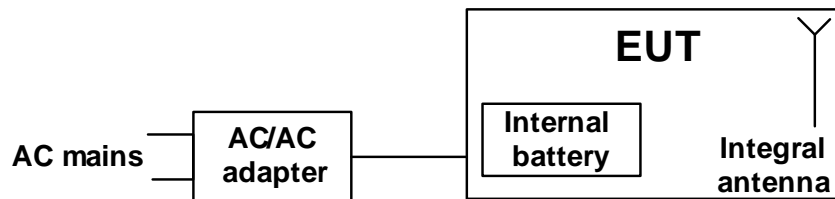

6.4 Changes made in the EUT

No changes were implemented in the EUT.



6.5 Transmitter characteristics

Type of equipment					
X	Stand-alone (Equipment with or without its own control provisions)				
	Combined equipment (Equipment where the radio part is fully integrated within another type of equipment)				
	Plug-in card (Equipment intended for a variety of host systems)				
Intended use		Condition of use			
	fixed	Always at a distance more than 2 m from all people			
X	mobile	Always at a distance more than 20 cm from all people			
	portable	May operate at a distance closer than 20 cm to human body			
Assigned frequency ranges		902 – 928 MHz			
Operating frequencies		912.750 – 919.106 MHz			
Maximum rated output power		At transmitter 50 Ω RF output connector		dBm	
		Peak output power		9.24 dBm	
Is transmitter output power variable?		X	No		
			Yes	continuous variable	
				stepped variable with stepsize	dB
				minimum RF power	dBm
				maximum RF power	dBm
Antenna connection					
unique coupling		standard connector		X	integral
					with temporary RF connector
				X	without temporary RF connector
Antenna/s technical characteristics					
Type	Manufacturer	Model number		Gain	
Integral	Visonic	Built-in wire antenna		2 dBi	
Transmitter aggregate data rate/s		50 kbps			
Type of modulation		GFSK			
Modulating test signal (baseband)		PRBS			
Maximum transmitter duty cycle in normal use		0.1%			
Transmitter power source					
X	Battery	Nominal rated voltage	4.8 VDC	Battery type	
X	AC mains	Nominal rated voltage	120 VAC	Frequency	60 Hz
Common power source for transmitter and receiver				X	yes
					no
Spread spectrum technique used		X	Frequency hopping (FHSS)		
			Digital transmission system (DTS)		
			Hybrid		
Spread spectrum parameters for transmitters tested per FCC 15.247 only					
FHSS	Total number of hops	50			
	Bandwidth per hop	98 kHz			
	Max. separation of hops	131 kHz			

Test specification: Section 15.247(a)1, 20 dB bandwidth			
Test procedure: Public notice DA 00-705			
Test mode: Compliance	Verdict: PASS		
Date: 12/10/2010			
Temperature: 23 °C	Air Pressure: 1018 hPa	Relative Humidity: 50 %	Power Supply: 120 VAC
Remarks:			

7 Transmitter tests according to 47CFR part 15 subpart C requirements

7.1 20 dB bandwidth

7.1.1 General

This test was performed to measure 20 dB bandwidth of the transmitter hopping channel. Specification test limits are given in Table 7.1.1.

Table 7.1.1 The 20 dB bandwidth limits

Assigned frequency, MHz	Maximum bandwidth, kHz	Modulation envelope reference points*, dBc
902.0 – 928.0	500	20
2400.0 – 2483.5	NA	
5725.0 – 5850.0	1000	

* - Modulation envelope reference points provided in terms of attenuation below the peak of modulated carrier.

7.1.2 Test procedure

- 7.1.2.1 The EUT was set up as shown in Figure 7.1.1, energized and its proper operation was checked.
- 7.1.2.2 The EUT was set to transmit modulated carrier at maximum data rate.
- 7.1.2.3 The transmitter bandwidth was measured with spectrum analyzer as frequency delta between reference points on modulation envelope and provided in Table 7.1.2 and associated plot.
- 7.1.2.4 The test was repeated for each data rate and each modulation format.

Figure 7.1.1 The 20 dB bandwidth test setup





Test specification:		Section 15.247(a)1, 20 dB bandwidth	
Test procedure:		Public notice DA 00-705	
Test mode:	Compliance	Verdict:	PASS
Date:	12/10/2010		
Temperature: 23 °C	Air Pressure: 1018 hPa	Relative Humidity: 50 %	Power Supply: 120 VAC
Remarks:			

Table 7.1.2 The 20 dB bandwidth test results

ASSIGNED FREQUENCY RANGE: 902-928 MHz
DETECTOR USED: Peak
SWEEP TIME: Auto
RESOLUTION BANDWIDTH: ≥ 1% of the 20 dB bandwidth
VIDEO BANDWIDTH: ≥ RBW
MODULATION ENVELOPE REFERENCE POINTS: 20.0 dBc
FREQUENCY HOPPING: Disabled

Carrier frequency, MHz	Type of modulation	Data rate, kbps	Symbol rate, Msymbols/s	20 dB bandwidth, kHz	Limit, kHz	Margin, kHz	Verdict
912.750	GFSK	50	NA	92.3	500	-407.7	Pass
915.863				92.3		-407.7	Pass
919.106				98.3		-401.7	Pass

Reference numbers of test equipment used

HL 0521	HL 0604	HL 2871	HL 3622				
---------	---------	---------	---------	--	--	--	--

Full description is given in Appendix A.

Test specification:	Section 15.247(a)1, 20 dB bandwidth		
Test procedure:	Public notice DA 00-705		
Test mode:	Compliance	Verdict:	PASS
Date:	12/10/2010		
Temperature: 23 °C	Air Pressure: 1018 hPa	Relative Humidity: 50 %	Power Supply: 120 VAC
Remarks:			

Plot 7.1.1 The 20 dB bandwidth test result at low frequency

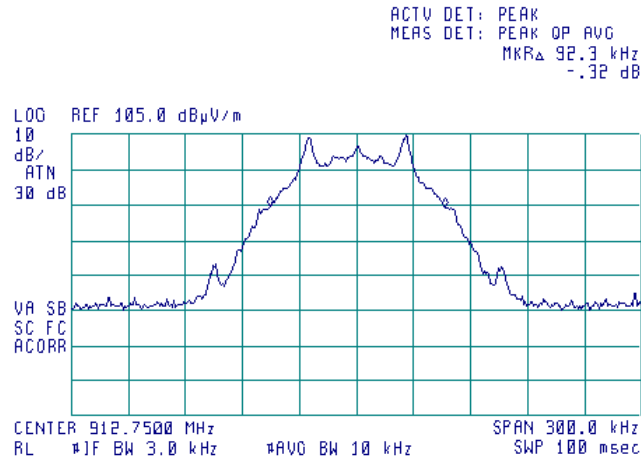

Plot 7.1.2 20 dB bandwidth test result at mid frequency

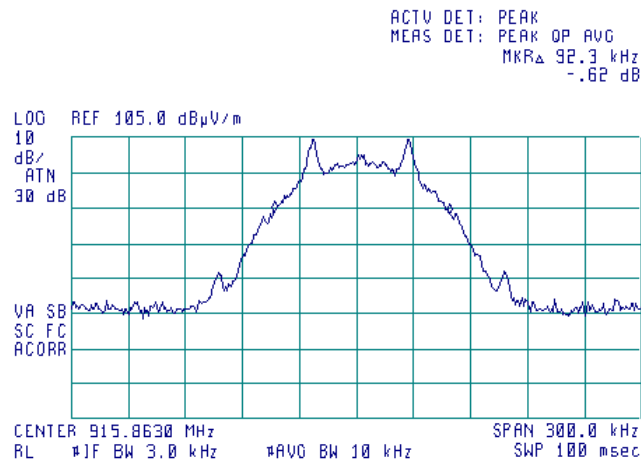



HERMON LABORATORIES

Test specification:	Section 15.247(a)1, 20 dB bandwidth		
Test procedure:	Public notice DA 00-705		
Test mode:	Compliance	Verdict:	PASS
Date:	12/10/2010		
Temperature: 23 °C	Air Pressure: 1018 hPa	Relative Humidity: 50 %	Power Supply: 120 VAC
Remarks:			

Plot 7.1.3 20 dB bandwidth test result at high frequency



ACTV DET: PEAK
MEAS DET: PEAK OP AVG
MKR Δ 98.3 kHz
-.19 dB

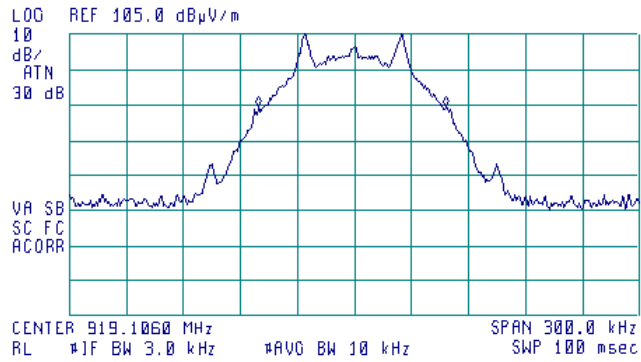

Test specification:	Section 15.247(a)1, Frequency separation		
Test procedure:	Public notice DA 00-705		
Test mode:	Compliance	Verdict:	PASS
Date:	12/20/2010		
Temperature: 22 °C	Air Pressure: 1021 hPa	Relative Humidity: 41 %	Power Supply: 120 VAC
Remarks:			

7.2 Carrier frequency separation

7.2.1 General

This test was performed to measure frequency separation between the peaks of adjacent channels. Specification test limits are given in Table 7.2.1.

Table 7.2.1 Carrier frequency separation limits

Assigned frequency range, MHz	Carrier frequency separation
902.0 – 928.0	25 kHz or 20 dB bandwidth of the hopping channel, whichever is greater
2400.0 – 2483.5	
5725.0 – 5850.0	

7.2.2 Test procedure

- 7.2.2.1 The EUT was set up as shown in Figure 7.2.1, energized with frequency hopping function enabled and its proper operation was checked.
- 7.2.2.2 The spectrum analyzer span was set to capture the carrier frequency and both of adjacent channels, the lower and the higher. The resolution bandwidth was set wider than 1 % of the frequency span.
- 7.2.2.3 The spectrum analyzer was set in max hold mode and allowed trace to stabilize.
- 7.2.2.4 The frequency separation between the peaks of adjacent channels was measured as provided in Table 7.2.2 and the associated plots.

Figure 7.2.1 Carrier frequency separation test setup



Test specification: Section 15.247(a)1, Frequency separation	
Test procedure: Public notice DA 00-705	
Test mode: Compliance	Verdict: PASS
Date: 12/20/2010	
Temperature: 22 °C	Air Pressure: 1021 hPa
Relative Humidity: 41 %	
Power Supply: 120 VAC	
Remarks:	

Table 7.2.2 Carrier frequency separation test results

ASSIGNED FREQUENCY RANGE: 902-928 MHz
 MODULATION: GFSK
 BIT RATE: 50 kbps
 DETECTOR USED: Peak
 RESOLUTION BANDWIDTH: ≥ 1% of the span
 VIDEO BANDWIDTH: ≥ RBW
 FREQUENCY HOPPING: Enabled
 20 dB BANDWIDTH: 101.3kHz

Carrier frequency separation, kHz	Limit, kHz	Margin*	Verdict
131	101.3	29.7	Pass

* - Margin = Carrier frequency separation – specification limit.

Reference numbers of test equipment used

HL 1431	HL 1984	HL 2883	HL 3386				
---------	---------	---------	---------	--	--	--	--

Full description is given in Appendix A.

Plot 7.2.1 Carrier frequency separation

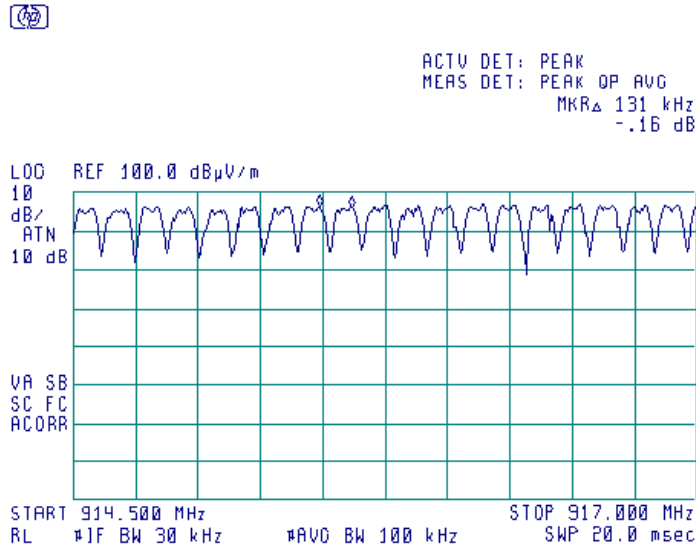

Test specification:	Section 15.247(a)1, Number of hopping frequencies		
Test procedure:	Public notice DA 00-705		
Test mode:	Compliance	Verdict:	PASS
Date:	12/12/2010		
Temperature: 22 °C	Air Pressure: 1001 hPa	Relative Humidity: 44 %	Power Supply: 120 VAC
Remarks:			

7.3 Number of hopping frequencies

7.3.1 General

This test was performed to calculate the number of hopping frequencies used by the EUT. Specification test limits are given in Table 7.3.1.

Table 7.3.1 Minimum number of hopping frequencies

Assigned frequency range, MHz	Number of hopping frequencies
902.0 – 928.0	50 (if the 20 dB bandwidth is less than 250 kHz) 25 (if the 20 dB bandwidth is 250 kHz or greater)
2400.0 – 2483.5	15
5725.0 – 5850.0	75

7.3.2 Test procedure

7.3.2.1 The EUT was set up as shown in Figure 7.3.1, energized with frequency hopping function enabled and its proper operation was checked.

7.3.2.2 Initially the spectrum analyzer span was set equal to frequency band of operation and the resolution bandwidth was set wider than 1 % of the frequency span. If the separate hopping channels were not clearly resolved the frequency band of operation was broken to sections and the resolution bandwidth was set wider than 1 % of the frequency span of each section.

7.3.2.3 The spectrum analyzer was set in max hold mode and allowed trace to stabilize.

7.3.2.4 The number of frequency hopping channels was calculated as provided in Table 7.3.2 and associated plots.

Figure 7.3.1 Hopping frequencies test setup



Test specification: Section 15.247(a)1, Number of hopping frequencies			
Test procedure: Public notice DA 00-705			
Test mode: Compliance	Verdict: PASS		
Date: 12/12/2010			
Temperature: 22 °C	Air Pressure: 1001 hPa	Relative Humidity: 44 %	Power Supply: 120 VAC
Remarks:			

Table 7.3.2 Hopping frequencies test results

ASSIGNED FREQUENCY RANGE: 902-928 MHz
 MODULATION: GFSK
 BIT RATE: 50 kbps
 DETECTOR USED: Peak
 RESOLUTION BANDWIDTH: ≥ 1% of the span
 VIDEO BANDWIDTH: ≥ RBW
 FREQUENCY HOPPING: Enabled

Number of hopping frequencies	Minimum number of hopping frequencies	Margin*	Verdict
50	50	0	PASS

* - Margin = Number of hopping frequencies – Minimum number of hopping frequencies.

Reference numbers of test equipment used

HL 1431	HL 2883	HL 3386	HL 1984				
---------	---------	---------	---------	--	--	--	--

Full description is given in Appendix A.

Plot 7.3.1 Number of hopping frequencies in the frequency range 912 –914.5 MHz (fourteen)

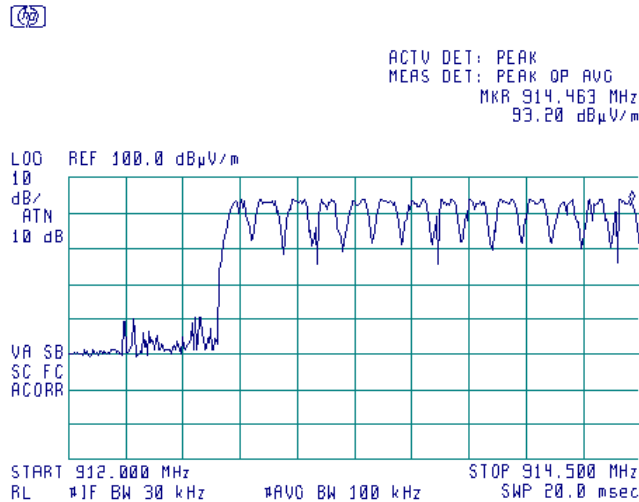

Test specification:	Section 15.247(a)1, Number of hopping frequencies		
Test procedure:	Public notice DA 00-705		
Test mode:	Compliance	Verdict:	PASS
Date:	12/12/2010		
Temperature: 22 °C	Air Pressure: 1001 hPa	Relative Humidity: 44 %	Power Supply: 120 VAC
Remarks:			

Plot 7.3.2 Number of hopping frequencies in the frequency range 914.5 –917.0 MHz (nineteen)

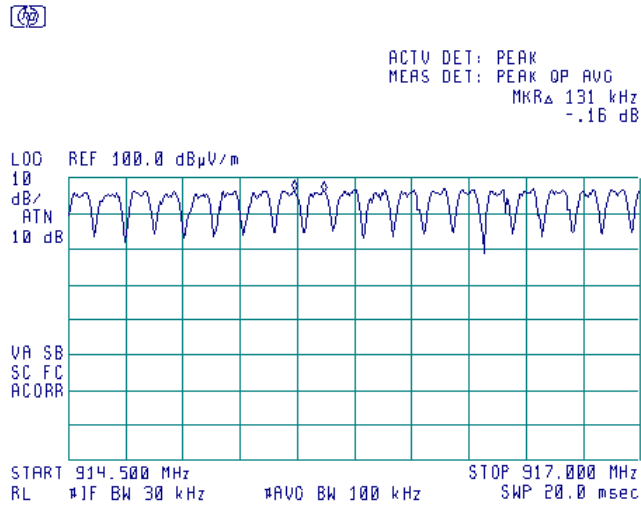

Plot 7.3.3 Number of hopping frequencies in the frequency range 917 –919.5 MHz (seventeen)

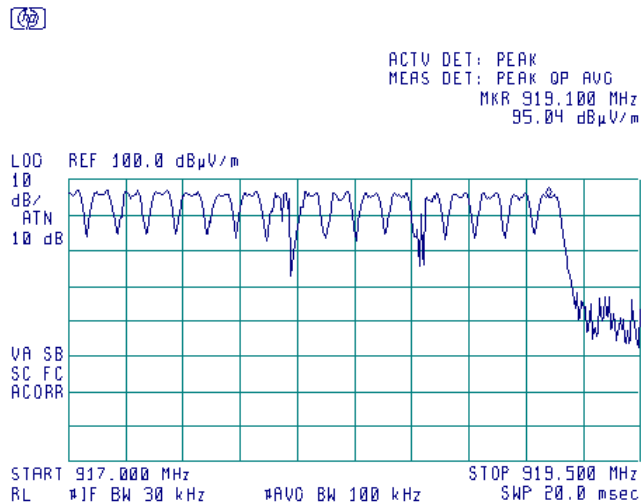



Test specification:		Section 15.247(a)1, Average time of occupancy	
Test procedure:		Public notice DA 00-705	
Test mode:	Compliance	Verdict:	PASS
Date:	12/12/2010		
Temperature: 22 °C	Air Pressure: 1001 hPa	Relative Humidity: 44 %	Power Supply: 120 VAC
Remarks:			

7.4 Average time of occupancy

The average time of occupancy (dwell time) on any frequency limit is given in Table 7.4.1.

Table 7.4.1 Average time of occupancy limits

Assigned frequency range, MHz	Maximum average time of occupancy, s	Investigated period, s	Number of hopping frequencies
902.0 – 928.0	0.4	20.0	≥ 50

According to the applicant's declaration the EUT complies with the FCC requirement: the average time of occupancy on any frequency shall not be greater than 0.4 seconds within a 20 seconds period. The Declaration provided in Appendix G attached to this test report.

Test specification:		Section 15.247(b), Peak output power	
Test procedure:		Public notice DA 00-705	
Test mode:	Compliance	Verdict:	PASS
Date:	12/10/2010		
Temperature: 24 °C	Air Pressure: hPa	Relative Humidity: 44 %	Power Supply: 120 VAC
Remarks:			

7.5 Peak output power

7.5.1 General

This test was performed to measure the maximum peak output power radiated by transmitter. Specification test limits are given in Table 7.5.1.

Table 7.5.1 Peak output power limits

Assigned frequency range MHz	Peak output power*		Equivalent field strength limit @ 3m, dB(μV/m)*	Maximum antenna gain, dBi
	W	dBm		
902.0 – 928.0	1.0	30.0	131.2	
2400.0 – 2483.5	0.125 (<75 hopping channels)	21.0 (<75 hopping channels)	122.2 (<75 hopping channels)	6.0*
	1.0 (≥75 hopping channels)	30.0 (≥75 hopping channels)	131.2 (≥75 hopping channels)	
5725.0 – 5850.0	1.0	30.0	131.2	

*- Equivalent field strength limit was calculated from the peak output power as follows: $E = \sqrt{(30 \times P \times G)/r}$, where P is peak output power in Watts, r is antenna to EUT distance in meters and G is transmitter antenna gain in dBi.

** - The limit is provided in terms of conducted RF power at the antenna connector. If transmitting antennas of directional gain greater than 6 dBi are used, the peak output power limit shall be reduced below the stated value as follows:

- by 1 dB for every 3 dB that the directional gain of antenna exceeds 6 dBi for fixed point-to-point transmitters operate in 2400-2483.5 MHz band;
- without any corresponding reduction for fixed point-to-point transmitters operate in 5725-5850 MHz band;
- by the amount in dB that the directional gain of antenna exceeds 6 dBi for the rest of transmitters.

7.5.2 Test procedure

7.5.2.1 The EUT was set up as shown in Figure 7.5.1, energized and its proper operation was checked.

7.5.2.2 The EUT was adjusted to produce maximum available to end user RF output power.

7.5.2.3 The frequency span of spectrum analyzer was set approximately 5 times wider than 20 dB bandwidth of the EUT and the resolution bandwidth was set wider than 20 dB bandwidth of the EUT. To find maximum radiation the turntable was rotated 360° and the measuring antenna height was swept in both vertical and horizontal polarizations.

7.5.2.4 The maximum field strength of the EUT carrier frequency was measured as provided in Table 7.5.2 and associated plots.

7.5.2.5 The maximum peak output power was calculated from the field strength of carrier as follows:

$$P = (E \times d)^2 / (30 \times G),$$

where P is the peak output power in W, E is the field strength in V/m, d is the test distance and G is the transmitter numeric antenna gain over an isotropic radiator.

The above equation was converted in logarithmic units for 3 m test distance:

$$\text{Peak output power in dBm} = \text{Field strength in dB}(\mu\text{V/m}) - \text{Transmitter antenna gain in dBi} - 95.2 \text{ dB}$$

7.5.2.6 The worst test results (the lowest margins) were recorded in Table 7.5.2.

Test specification:	Section 15.247(b), Peak output power		
Test procedure:	Public notice DA 00-705		
Test mode:	Compliance	Verdict:	PASS
Date:	12/10/2010		
Temperature: 24 °C	Air Pressure: hPa	Relative Humidity: 44 %	Power Supply: 120 VAC
Remarks:			

Figure 7.5.1 Setup for carrier field strength measurements

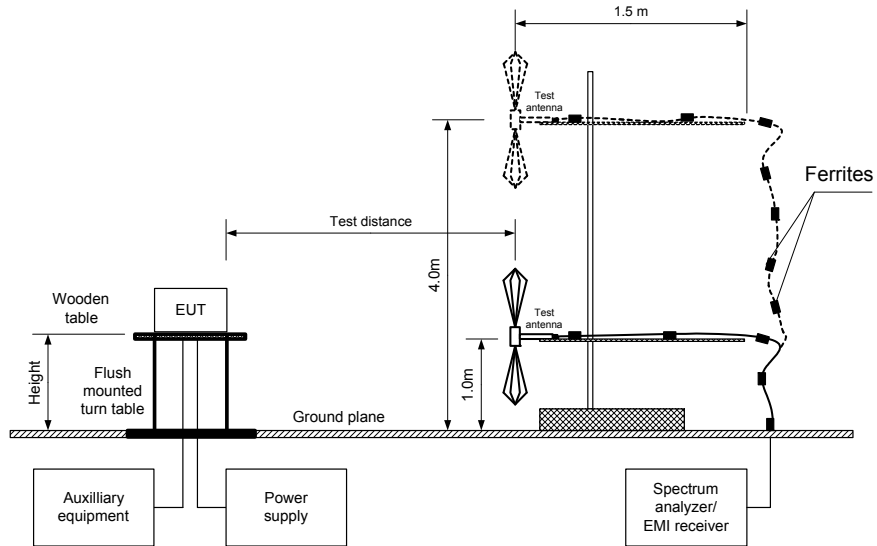



HERMON LABORATORIES

Test specification: Section 15.247(b), Peak output power	
Test procedure: Public notice DA 00-705	
Test mode: Compliance	Verdict: PASS
Date: 12/10/2010	
Temperature: 24 °C	Air Pressure: hPa
Relative Humidity: 44 %	
Power Supply: 120 VAC	
Remarks:	

Table 7.5.2 Peak output power test results

ASSIGNED FREQUENCY RANGE: 902-928 MHz
 TEST DISTANCE: 3 m
 TEST SITE: Semi anechoic chamber
 EUT HEIGHT: 0.8 m
 DETECTOR USED: Peak
 TEST ANTENNA TYPE: Biconilog (30 MHz – 1000 MHz)
 Double ridged guide (above 1000 MHz)
 MODULATION: GFSK
 BIT RATE: 50 kbps
 TRANSMITTER OUTPUT POWER SETTINGS: Maximum
 DETECTOR USED: Peak
 EUT 20 dB BANDWIDTH: 98.3 kHz
 RESOLUTION BANDWIDTH: 120 kHz
 VIDEO BANDWIDTH: 300 kHz
 FREQUENCY HOPPING: Disabled
 NUMBER OF FREQUENCY HOPPING CHANNELS: 50

Frequency, MHz	Field strength, dB(µV/m)	Antenna polarization	Antenna height, m	Azimuth, degrees*	EUT antenna gain, dBi	Peak output power, dBm**	Limit, dBm	Margin, dB***	Verdict
912.750	105.76	V	1.1	45	2	8.56	30	-21.44	Pass
915.863	105.24	V	1.1	50	2	8.04	30	-21.96	Pass
919.106	106.44	V	1.1	45	2	9.24	30	-20.76	Pass

*- EUT front panel refer to 0 degrees position of turntable.

**-. Peak output power was calculated from the field strength of carrier as follows: $P = (E \times d)^2 / (30 \times G)$, where P is the peak output power in W, E is the field strength in V/m, d is the test distance in meters and G is the transmitter numeric antenna gain over an isotropic radiator. The above equation was converted in logarithmic units for 3 m test distance: *Peak output power in dBm = Field strength in dB(µV/m) - Transmitter antenna gain in dBi - 95.2 dB*

***- Margin = Peak output power – specification limit.

Reference numbers of test equipment used

HL 0521	HL 0604	HL 2871	HL 3622	HL 4051			
---------	---------	---------	---------	---------	--	--	--

Full description is given in Appendix A.

Test specification:	Section 15.247(b), Peak output power		
Test procedure:	Public notice DA 00-705		
Test mode:	Compliance	Verdict:	PASS
Date:	12/10/2010		
Temperature: 24 °C	Air Pressure: hPa	Relative Humidity: 44 %	Power Supply: 120 VAC
Remarks:			

Plot 7.5.1 Field strength of carrier at low frequency and Unom

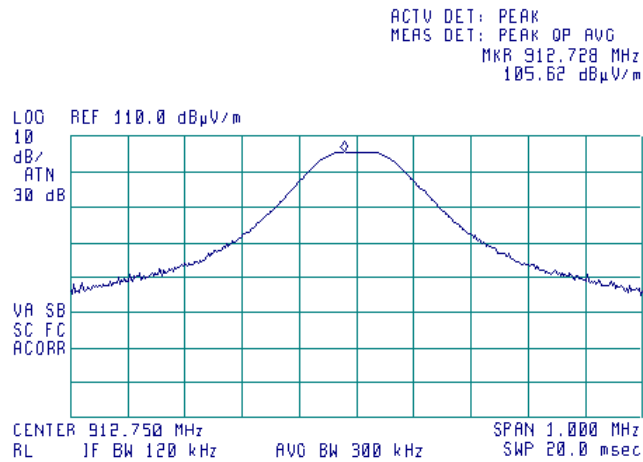

Plot 7.5.2 Field strength of carrier at mid frequency and Unom

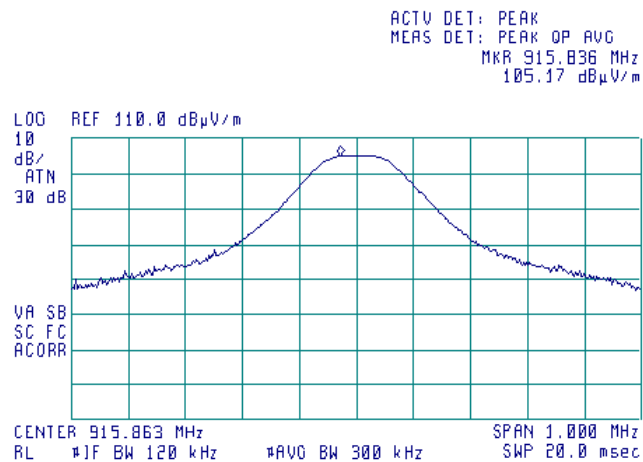

Test specification:	Section 15.247(b), Peak output power		
Test procedure:	Public notice DA 00-705		
Test mode:	Compliance	Verdict:	PASS
Date:	12/10/2010		
Temperature: 24 °C	Air Pressure: hPa	Relative Humidity: 44 %	Power Supply: 120 VAC
Remarks:			

Plot 7.5.3 Field strength of carrier at high frequency and Unom

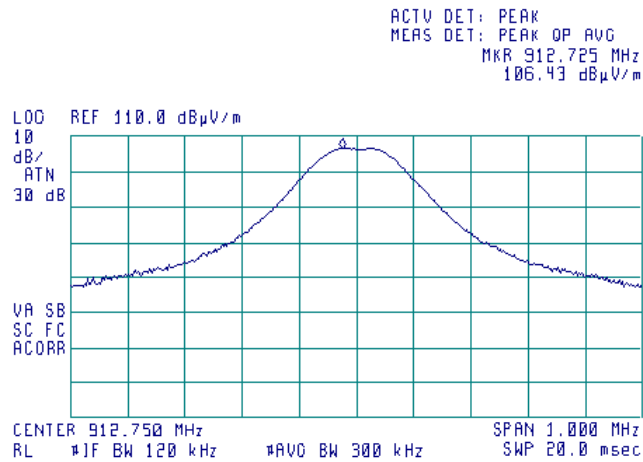

Plot 7.5.4 Peak output power at low frequency and 115%Unom

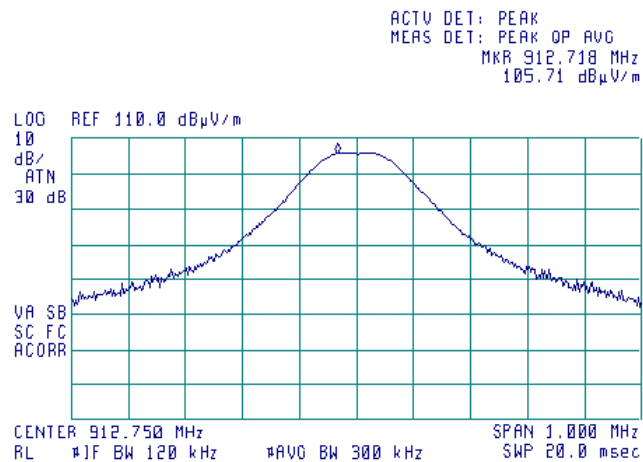

Test specification:	Section 15.247(b), Peak output power		
Test procedure:	Public notice DA 00-705		
Test mode:	Compliance	Verdict:	PASS
Date:	12/10/2010		
Temperature: 24 °C	Air Pressure: hPa	Relative Humidity: 44 %	Power Supply: 120 VAC
Remarks:			

Plot 7.5.5 Peak output power at mid frequency and 115%Unom

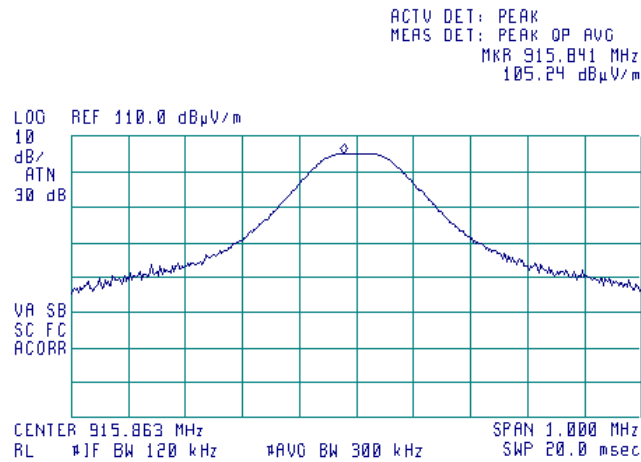

Plot 7.5.6 Peak output power at high frequency and 115%Unom

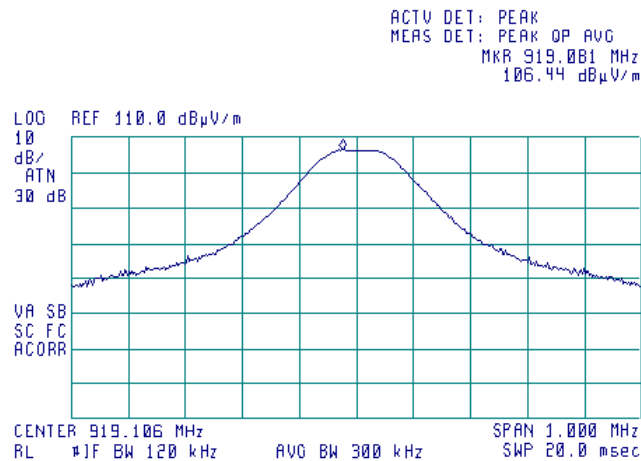

Test specification:	Section 15.247(b), Peak output power		
Test procedure:	Public notice DA 00-705		
Test mode:	Compliance	Verdict:	PASS
Date:	12/10/2010		
Temperature: 24 °C	Air Pressure: hPa	Relative Humidity: 44 %	Power Supply: 120 VAC
Remarks:			

Plot 7.5.7 Peak output power at low frequency and 85%Unom

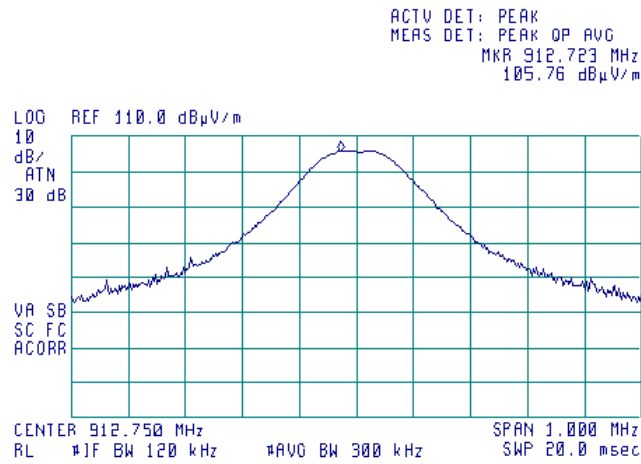

Plot 7.5.8 Peak output power at mid frequency and 85%Unom

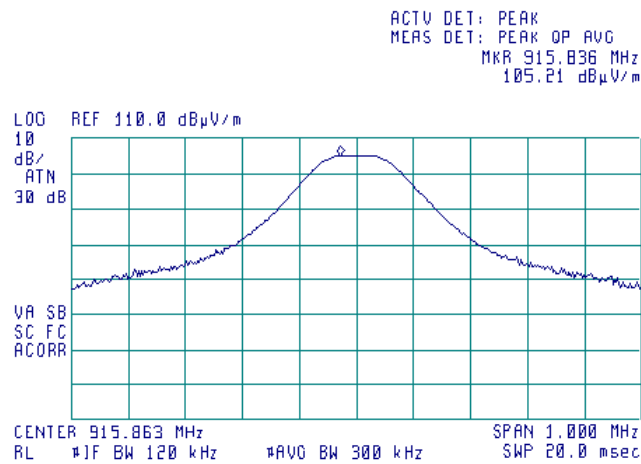



HERMON LABORATORIES

Test specification:	Section 15.247(b), Peak output power		
Test procedure:	Public notice DA 00-705		
Test mode:	Compliance	Verdict:	PASS
Date:	12/10/2010		
Temperature: 24 °C	Air Pressure: hPa	Relative Humidity: 44 %	Power Supply: 120 VAC
Remarks:			

Plot 7.5.9 Peak output power at high frequency and 85%Unom

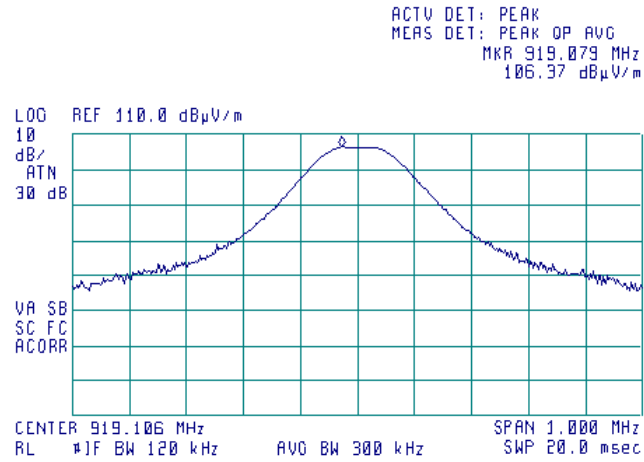

Test specification: Section 15.247(d), Emissions at band edges	
Test procedure: Public notice DA 00-705	
Test mode: Compliance	Verdict: PASS
Date: 12/22/2010	
Temperature: 23 °C	Air Pressure: 1018 hPa
Relative Humidity: 50 %	
Power Supply: 120 VAC	
Remarks:	

7.6 Band edge radiated emissions

7.6.1 General

This test was performed to measure emissions, radiated from the EUT at the assigned frequency band edges. Specification test limits are given in Table 7.6.1.

Table 7.6.1 Band edge emission limits

Assigned frequency, MHz	Attenuation below carrier*, dBc	Field strength at 3 m within restricted bands, dB(μV/m)	
		Peak	Average
902.0 – 928.0	20.0	74.0	54.0
2400.0 – 2483.5			
5725.0 – 5850.0			

* - Band edge emission limit is provided in terms of attenuation below the peak of modulated carrier measured with the same resolution bandwidth.

7.6.2 Test procedure

- 7.6.2.1 The EUT was set up as shown in Figure 7.6.1, energized normally modulated at the maximum data rate with its hopping function disabled and its proper operation was checked.
- 7.6.2.2 The EUT was adjusted to produce maximum available to end user RF output power at the lowest carrier frequency.
- 7.6.2.3 The spectrum analyzer span was set to capture the carrier frequency and associated modulation products. The resolution bandwidth was set wider than 1 % of the frequency span.
- 7.6.2.4 The spectrum analyzer was set in max hold mode and allowed trace to stabilize. The highest emission level within the authorized band was measured.
- 7.6.2.5 The maximum band edge emission and modulation product outside of the band were measured as provided in Table 7.6.2 and associated plots and referenced to the highest emission level measured within the authorized band.
- 7.6.2.6 The above procedure was repeated with the EUT adjusted to produce maximum RF output power at the highest carrier frequency.
- 7.6.2.7 The above procedure was repeated with the frequency hopping function enabled.

Figure 7.6.1 Band edge emission test setup





HERMON LABORATORIES

Test specification:		Section 15.247(d), Emissions at band edges	
Test procedure:		Public notice DA 00-705	
Test mode:	Compliance	Verdict:	PASS
Date:	12/22/2010		
Temperature: 23 °C	Air Pressure: 1018 hPa	Relative Humidity: 50 %	Power Supply: 120 VAC
Remarks:			

Table 7.6.2 Band edge emission test results

ASSIGNED FREQUENCY RANGE: 902-928 MHz
DETECTOR USED: Peak
MODULATION: GFSK
BIT RATE: 50 kbps
TRANSMITTER OUTPUT POWER SETTINGS: Maximum
RESOLUTION BANDWIDTH: ≥ 1% of the span
VIDEO BANDWIDTH: ≥ RBW

Frequency, MHz	Band edge emission, dBuV/m	Emission at carrier, dBuV/m	Attenuation below carrier, dBc	Limit, dBc	Margin, dB*	Verdict
Frequency hopping disabled						
902	63.75	105.62	41.87	20.0	21.87	Pass
928	65.11	106.43	41.32		21.32	
Frequency hopping enabled						
902	38.28	105.60	67.32	20.0	47.32	Pass
928	47.68	106.43	58.75		38.75	

*- Margin = Attenuation below carrier – specification limit.

Reference numbers of test equipment used

HL 0521	HL 0604	HL 2871	HL 3622				
---------	---------	---------	---------	--	--	--	--

Full description is given in Appendix A.

Test specification:	Section 15.247(d), Emissions at band edges		
Test procedure:	Public notice DA 00-705		
Test mode:	Compliance	Verdict:	PASS
Date:	12/22/2010		
Temperature: 23 °C	Air Pressure: 1018 hPa	Relative Humidity: 50 %	Power Supply: 120 VAC
Remarks:			

Plot 7.6.1 The highest emission level within the assigned band at low carrier frequency

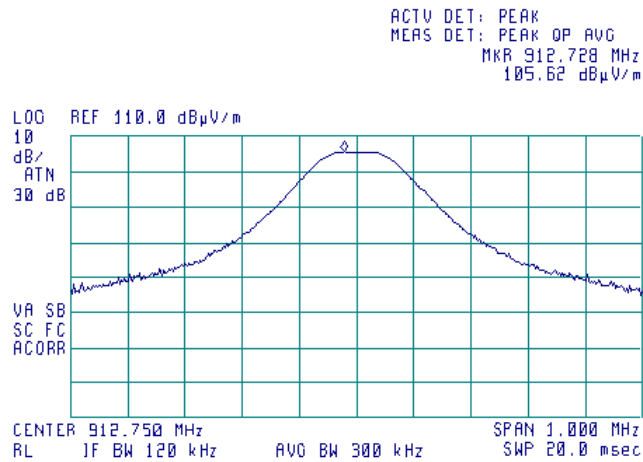

Plot 7.6.2 The highest emission level within the assigned band at high carrier frequency

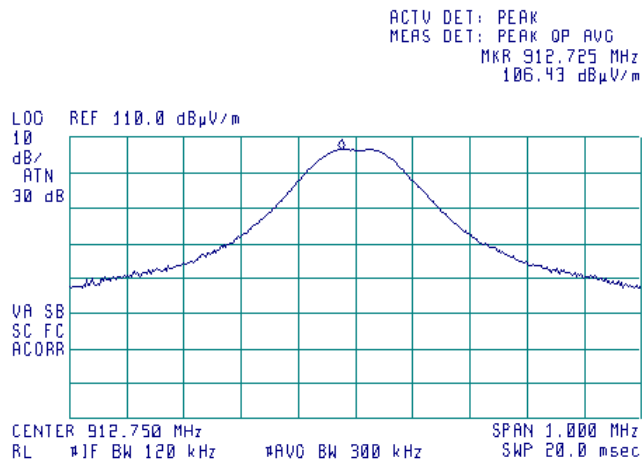

Test specification: Section 15.247(d), Emissions at band edges			
Test procedure: Public notice DA 00-705			
Test mode: Compliance	Verdict: PASS		
Date: 12/22/2010			
Temperature: 23 °C	Air Pressure: 1018 hPa	Relative Humidity: 50 %	Power Supply: 120 VAC
Remarks:			

Plot 7.6.3 The highest band edge emission at low carrier frequency with hopping function disabled

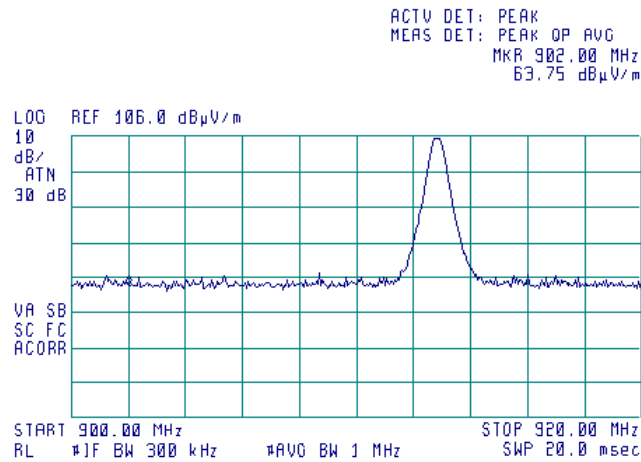

Plot 7.6.4 The highest band edge emission at high carrier frequency with hopping function disabled

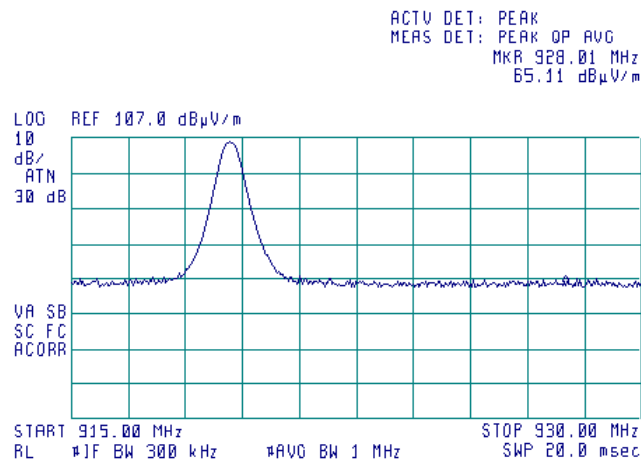

Test specification: Section 15.247(d), Emissions at band edges			
Test procedure: Public notice DA 00-705			
Test mode: Compliance	Verdict: PASS		
Date: 12/22/2010			
Temperature: 23 °C	Air Pressure: 1018 hPa	Relative Humidity: 50 %	Power Supply: 120 VAC
Remarks:			

Plot 7.6.5 The highest band edge emission at low carrier frequency with hopping function enabled

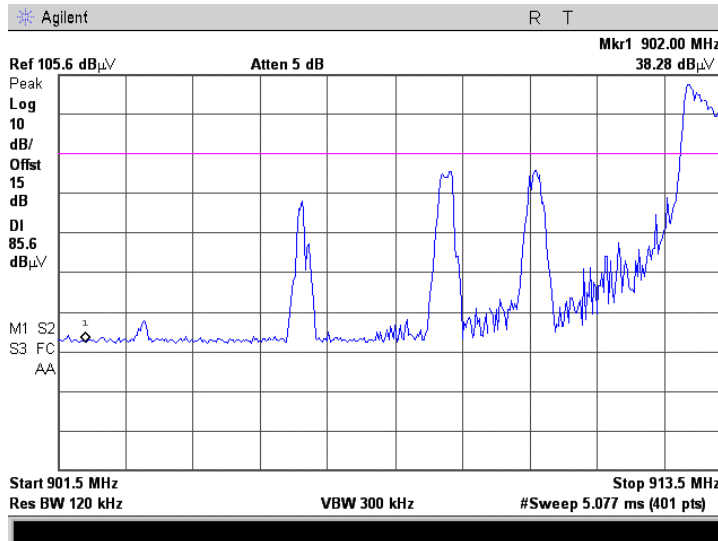

Plot 7.6.6 The highest band edge emission at high carrier frequency with hopping function enabled

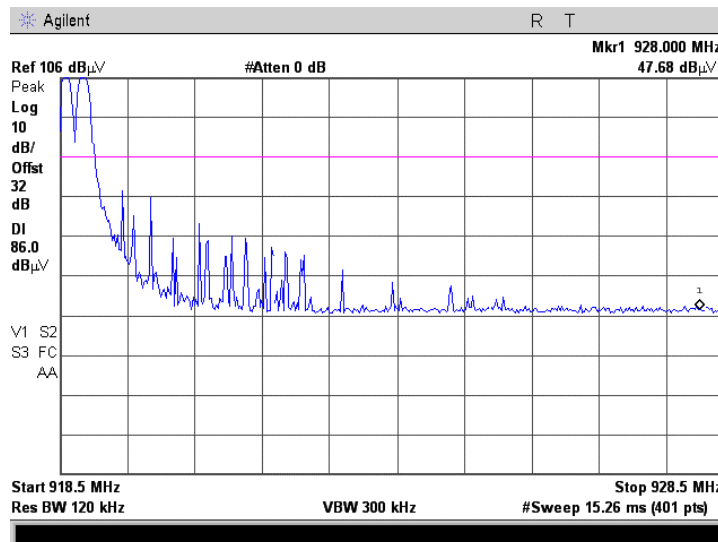

Test specification:		Section 15.247(d), Radiated spurious emissions	
Test procedure:		Public notice DA 00-705/ 47 CFR, Section 15.247(c) / ANSI C63.4, Section 13.1.4	
Test mode:	Compliance	Verdict:	PASS
Date:	12/20/2010		
Temperature: 23 °C	Air Pressure: 1018 hPa	Relative Humidity: 50 %	Power Supply: 120 VAC
Remarks:			

7.7 Field strength of spurious emissions

7.7.1 General

This test was performed to measure field strength of spurious emissions from the EUT. Specification test limits are given in Table 7.7.1.

Table 7.7.1 Radiated spurious emissions limits

Frequency, MHz	Field strength at 3 m within restricted bands, dB(μV/m) ^{***}			Attenuation of field strength of spurious versus carrier outside restricted bands, dBc ^{***}
	Peak	Quasi Peak	Average	
0.009 – 0.090	148.5 – 128.5	NA	128.5 – 108.5 ^{**}	20.0
0.090 – 0.110	NA	108.5 – 106.8 ^{**}	NA	
0.110 – 0.490	126.8 – 113.8	NA	106.8 – 93.8 ^{**}	
0.490 – 1.705	NA	73.8 – 63.0 ^{**}	NA	
1.705 – 30.0*		69.5		
30 – 88		40.0		
88 – 216		43.5		
216 – 960		46.0		
960 – 1000		54.0		
1000 – 10 th harmonic	74.0	NA	54.0	

*- The limit for 3 m test distance was calculated using the inverse square distance extrapolation factor as follows:

$$\text{Lim}_{S_2} = \text{Lim}_{S_1} + 40 \log(S_1/S_2),$$

where S_1 and S_2 – standard defined and test distance respectively in meters.

** - The limit decreases linearly with the logarithm of frequency.

*** - The field strength limits applied from the lowest radio frequency generated in the device, without going below 9 kHz up to the tenth harmonic of the highest fundamental frequency.

7.7.2 Test procedure for spurious emission field strength measurements in 9 kHz to 30 MHz band

7.7.2.1 The EUT was set up as shown in Figure 7.7.1, energized and the performance check was conducted.

7.7.2.2 The specified frequency range was investigated with antenna connected to spectrum analyzer/ EMI receiver. To find maximum radiation the turntable was rotated 360° and the measuring antenna was rotated around its vertical axis.

7.7.2.3 The worst test results (the lowest margins) were recorded and shown in the associated plots.

7.7.3 Test procedure for spurious emission field strength measurements above 30 MHz

7.7.3.1 The EUT was set up as shown in Figure 7.7.2, energized and the performance check was conducted.

7.7.3.2 The specified frequency range was investigated with antenna connected to spectrum analyzer/ EMI receiver. To find maximum radiation the turntable was rotated 360°, the measuring antenna height was changed from 1 to 4 m, its polarization was switched from vertical to horizontal.

7.7.3.3 The worst test results (the lowest margins) were recorded and shown in the associated plots.

Test specification: Section 15.247(d), Radiated spurious emissions			
Test procedure: Public notice DA 00-705/ 47 CFR, Section 15.247(c) / ANSI C63.4, Section 13.1.4			
Test mode: Compliance	Verdict: PASS		
Date: 12/20/2010			
Temperature: 23 °C	Air Pressure: 1018 hPa	Relative Humidity: 50 %	Power Supply: 120 VAC
Remarks:			

Figure 7.7.1 Setup for spurious emission field strength measurements below 30 MHz

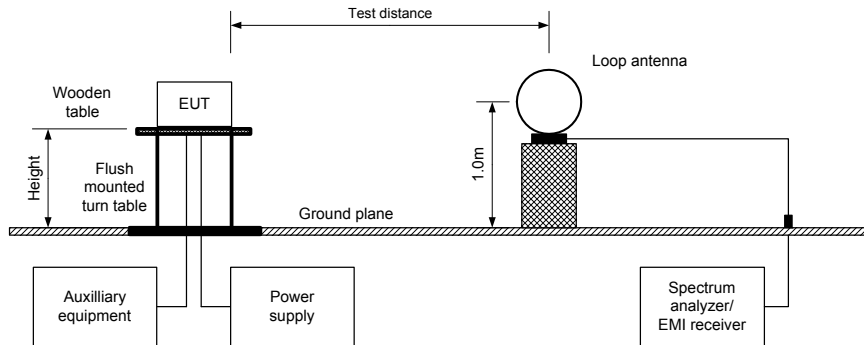
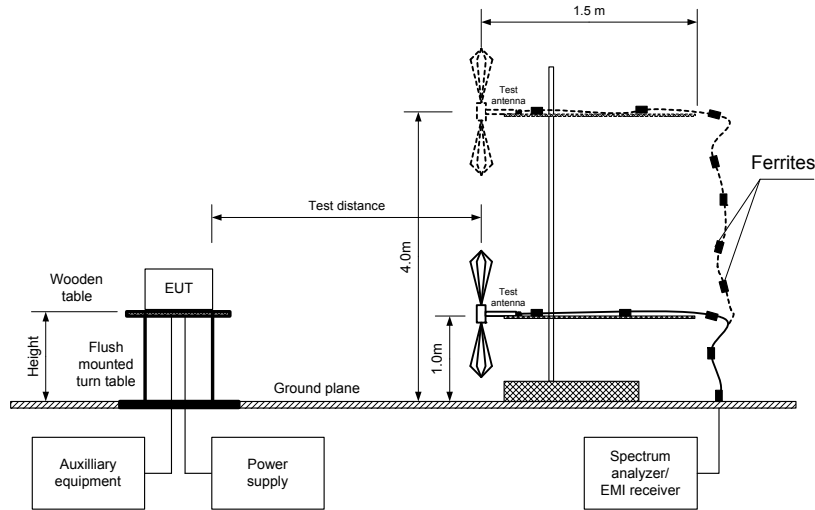

Figure 7.7.2 Setup for spurious emission field strength measurements above 30 MHz





Test specification: Section 15.247(d), Radiated spurious emissions	
Test procedure: Public notice DA 00-705/ 47 CFR, Section 15.247(c) / ANSI C63.4, Section 13.1.4	
Test mode: Compliance	Verdict: PASS
Date: 12/20/2010	
Temperature: 23 °C	Air Pressure: 1018 hPa
Relative Humidity: 50 %	
Power Supply: 120 VAC	
Remarks:	

Table 7.7.2 Field strength of emissions outside restricted bands

ASSIGNED FREQUENCY RANGE: 902-928 MHz
 INVESTIGATED FREQUENCY RANGE: 0.009 - 9300 MHz
 TEST DISTANCE: 3 m
 MODULATION: GFSK
 MODULATING SIGNAL: PRBS
 BIT RATE: 50 Kbps
 DUTY CYCLE: 100 %
 TRANSMITTER OUTPUT POWER SETTINGS: Maximum
 DETECTOR USED: Peak
 RESOLUTION BANDWIDTH: 100 kHz
 VIDEO BANDWIDTH: 300 kHz
 TEST ANTENNA TYPE: Active loop (9 kHz – 30 MHz)
 Biconilog (30 MHz – 1000 MHz)
 Double ridged guide (above 1000 MHz)
 FREQUENCY HOPPING: Disabled

Frequency, MHz	Field strength of spurious, dB(µV/m)	Antenna polarization	Antenna height, m	Azimuth, degrees*	Field strength of carrier, dB(µV/m)	Attenuation below carrier, dBc	Limit, dBc	Margin, dB**	Verdict
Low carrier frequency									
1825.458	42.17	V	2.1	90	105.62	63.45	20.0	43.45	Pass
5476.358	51.24	H	1.7	350		54.38		34.38	
6389.420	38.39	H	1.8	30		67.23		47.23	
Mid carrier frequency									
1831.771	47.36	V	1.9	120	105.17	57.81	20.0	37.81	Pass
5495.322	54.01	H	1.9	340		51.16		31.16	
6410.857	40.20	H	1.4	340		64.97		44.97	
High carrier frequency									
1838.159	46.44	V	2.0	90	106.43	59.99	20.0	39.99	Pass
5514.486	52.22	H	1.9	330		54.21		34.21	
6433.558	42.63	H	1.8	330		63.80		43.80	

*- EUT front panel refers to 0 degrees position of turntable.
 **- Margin = Attenuation below carrier – specification limit.

Test specification:	Section 15.247(d), Radiated spurious emissions		
Test procedure:	Public notice DA 00-705/ 47 CFR, Section 15.247(c) / ANSI C63.4, Section 13.1.4		
Test mode:	Compliance	Verdict: PASS	
Date:	12/20/2010		
Temperature: 23 °C	Air Pressure: 1018 hPa	Relative Humidity: 50 %	Power Supply: 120 VAC
Remarks:			

Table 7.7.3 Field strength of spurious emissions above 1 GHz within restricted bands

ASSIGNED FREQUENCY RANGE: 902-928 MHz
 INVESTIGATED FREQUENCY RANGE: 1000 - 9300 MHz
 TEST DISTANCE: 3 m
 MODULATION: GFSK
 BIT RATE: 50 kbps
 DUTY CYCLE: 100 %
 TRANSMITTER OUTPUT POWER SETTINGS: Maximum
 DETECTOR USED: Peak
 RESOLUTION BANDWIDTH: 1000 kHz
 TEST ANTENNA TYPE: Double ridged guide
 FREQUENCY HOPPING: Disabled

Frequency, MHz	Antenna		Azimuth, degrees*	Peak field strength(VBW=3 MHz)			Average field strength(VBW=10 Hz)				Verdict
	Polarization	Height, m		Measured, dB(μV/m)	Limit, dB(μV/m)	Margin, dB**	Measured, dB(μV/m)	Calculated, dB(μV/m)	Limit, dB(μV/m)	Margin, dB***	
Low carrier frequency											
2738.265	H	1.0	0	46.85	74	-27.15	42.99	35.50	54	-18.50	Pass
7302.010	H	2.0	0	52.16	74	-21.84	46.77	39.28	54	-14.72	
9127.540	H	1.8	90	50.49	74	-23.51	40.34	32.85	54	-21.15	
Mid carrier frequency											
2747.599	H	1.0	0	47.44	74	-26.56	43.99	36.50	54	-17.50	Pass
7326.919	H	1.5	0	54.05	74	-19.95	49.78	42.29	54	-11.71	
9158.660	H	1.5	60	51.93	74	-22.07	44.53	37.04	54	-16.96	
High carrier frequency											
2757.330	H	1.0	0	48.17	74	-25.83	45.07	37.58	54	-16.42	Pass
7352.843	H	1.7	60	52.97	74	-21.03	48.28	40.79	54	-13.21	
9191.050	H	1.5	60	51.76	74	-22.24	45.06	37.57	54	-16.43	

*- EUT front panel refers to 0 degrees position of turntable.
 **- Margin = Measured field strength - specification limit.
 ***- Margin = Calculated field strength - specification limit,
 where Calculated field strength = Measured field strength + average factor.

Table 7.7.4 Average factor calculation

Transmission pulse		Transmission burst		Transmission train duration, ms	Average factor, dB**
Duration, ms*	Period, ms	Duration, ms	Period, ms		
42.24	>100	NA	NA	NA	-7.49

* - according to manufacturer declaration
 **- average factor was calculated as follows: $20 \log(42.24/100) = -7.49$ dB
 for pulse train shorter than 100 ms: $Average\ factor = 20 \times \log_{10} \left(\frac{Pulse\ duration}{Pulse\ period} \times \frac{Burst\ duration}{Train\ duration} \times Number\ of\ bursts\ within\ pulse\ train \right)$
 for pulse train longer than 100 ms: $Average\ factor = 20 \times \log_{10} \left(\frac{Pulse\ duration}{Pulse\ period} \times \frac{Burst\ duration}{100\ ms} \times Number\ of\ bursts\ within\ 100\ ms \right)$

Test specification: Section 15.247(d), Radiated spurious emissions			
Test procedure: Public notice DA 00-705/ 47 CFR, Section 15.247(c) / ANSI C63.4, Section 13.1.4			
Test mode: Compliance	Verdict: PASS		
Date: 12/20/2010			
Temperature: 23 °C	Air Pressure: 1018 hPa	Relative Humidity: 50 %	Power Supply: 120 VAC
Remarks:			

Table 7.7.5 Field strength of spurious emissions below 1 GHz within restricted bands

ASSIGNED FREQUENCY RANGE: 902-928 MHz
 INVESTIGATED FREQUENCY RANGE: 0.009 – 1000 MHz
 TEST DISTANCE: 3 m
 MODULATION: GFSK
 MODULATING SIGNAL: PRBS
 BIT RATE: 50 kbps
 DUTY CYCLE: 100 %
 TRANSMITTER OUTPUT POWER SETTINGS: Maximum
 RESOLUTION BANDWIDTH: 0.2 kHz (9 kHz – 150 kHz)
 9.0 kHz (150 kHz – 30 MHz)
 120 kHz (30 MHz – 1000 MHz)
 VIDEO BANDWIDTH: > Resolution bandwidth
 TEST ANTENNA TYPE: Active loop (9 kHz – 30 MHz)
 Biconilog (30 MHz – 1000 MHz)
 FREQUENCY HOPPING: Disabled

Frequency MHz	Peak emission, dB(µV/m)	Quasi-peak			Antenna polarization	Antenna height, m	Turn-table position**, degrees	Verdict
		Measured emission, dB(µV/m)	Limit, dB(µV/m)	Margin, dB				
No spurious emissions were found								Pass

*- Margin = Measured emission - specification limit.

**-. EUT front panel refer to 0 degrees position of turntable.

Table 7.7.6 Restricted bands

MHz	MHz	MHz	MHz	MHz	GHz
0.09 - 0.11	8.37625 - 8.38675	73 - 74.6	399.9 - 410	2690 - 2900	10.6 - 12.7
0.495 - 0.505	8.41425 - 8.41475	74.8 - 75.2	608 - 614	3260 - 3267	13.25 - 13.4
2.1735 - 2.1905	12.29 - 12.293	108 - 121.94	960 - 1240	3332 - 3339	14.47 - 14.5
4.125 - 4.128	12.51975 - 12.52025	123 - 138	1300 - 1427	3345.8 - 3358	15.35 - 16.2
4.17725 - 4.17775	12.57675 - 12.57725	149.9 - 150.05	1435 - 1626.5	3600 - 4400	17.7 - 21.4
4.20725 - 4.20775	13.36 - 13.41	156.52475 - 156.52525	1645.5 - 1646.5	4500 - 5150	22.01 - 23.12
6.215 - 6.218	16.42 - 16.423	156.7 - 156.9	1660 - 1710	5350 - 5460	23.6 - 24
6.26775 - 6.26825	16.69475 - 16.69525	162.0125 - 167.17	1718.8 - 1722.2	7250 - 7750	31.2 - 31.8
6.31175 - 6.31225	16.80425 - 16.80475	167.72 - 173.2	2200 - 2300	8025 - 8500	36.43 - 36.5
8.291 - 8.294	25.5 - 25.67	240 - 285	2310 - 2390	9000 - 9200	Above 38.6
8.362 - 8.366	37.5 - 38.25	322 - 335.4	2483.5 - 2500	9300 - 9500	

Reference numbers of test equipment used

HL 0446	HL 0521	HL 0604	HL 2432	HL 2780	HL 2871	HL 3123	HL 3341
HL 3343	HL 3346	HL 3622	HL 3883				

Full description is given in Appendix A.

Test specification: Section 15.247(d), Radiated spurious emissions			
Test procedure: Public notice DA 00-705/ 47 CFR, Section 15.247(c) / ANSI C63.4, Section 13.1.4			
Test mode: Compliance	Verdict: PASS		
Date: 12/20/2010			
Temperature: 23 °C	Air Pressure: 1018 hPa	Relative Humidity: 50 %	Power Supply: 120 VAC
Remarks:			

Plot 7.7.1 Radiated emission measurements at the low carrier frequency

TEST SITE: Semi anechoic chamber
TEST DISTANCE: 3 m
ANTENNA POLARIZATION: Vertical & Horizontal

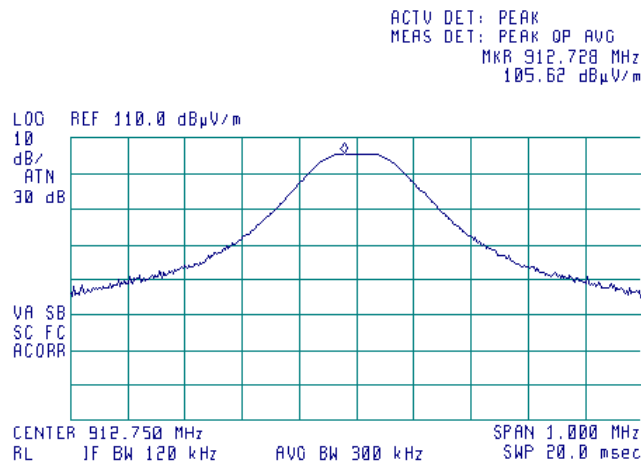

Plot 7.7.2 Radiated emission measurements at the mid carrier frequency

TEST SITE: Semi anechoic chamber
TEST DISTANCE: 3 m
ANTENNA POLARIZATION: Vertical & Horizontal

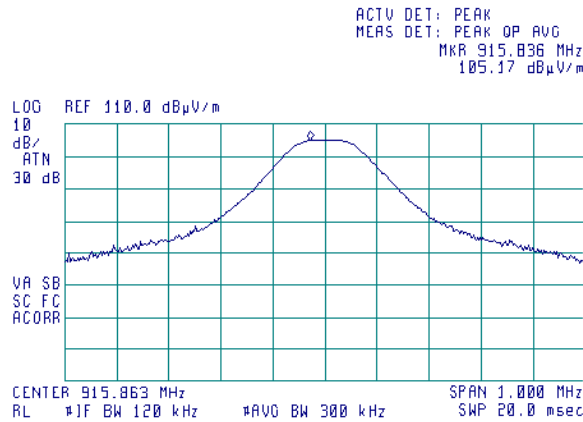



HERMON LABORATORIES

Test specification:		Section 15.247(d), Radiated spurious emissions	
Test procedure:		Public notice DA 00-705/ 47 CFR, Section 15.247(c) / ANSI C63.4, Section 13.1.4	
Test mode:	Compliance	Verdict:	PASS
Date:	12/20/2010		
Temperature: 23 °C	Air Pressure: 1018 hPa	Relative Humidity: 50 %	Power Supply: 120 VAC
Remarks:			

Plot 7.7.3 Radiated emission measurements at the high carrier frequency

TEST SITE: Semi anechoic chamber
TEST DISTANCE: 3 m
ANTENNA POLARIZATION: Vertical & Horizontal



ACTV DET: PEAK
MEAS DET: PEAK QP AVG
MKR 912.725 MHz
106.43 dBµV/m

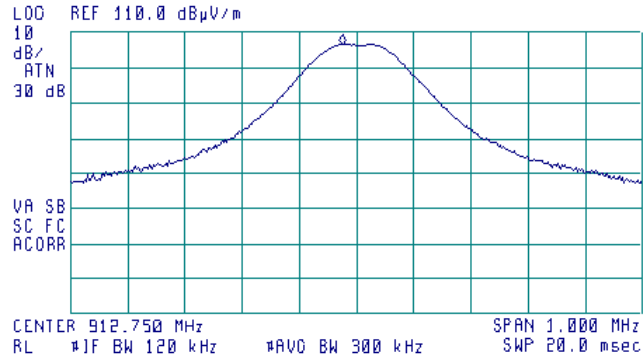

Test specification: Section 15.247(d), Radiated spurious emissions			
Test procedure: Public notice DA 00-705/ 47 CFR, Section 15.247(c) / ANSI C63.4, Section 13.1.4			
Test mode: Compliance	Verdict: PASS		
Date: 12/20/2010			
Temperature: 23 °C	Air Pressure: 1018 hPa	Relative Humidity: 50 %	Power Supply: 120 VAC
Remarks:			

Plot 7.7.4 Radiated emission measurements from 9 to 150 kHz at the low, mid and high carrier frequency

TEST SITE: Semi anechoic chamber
TEST DISTANCE: 3 m
ANTENNA POLARIZATION: Vertical

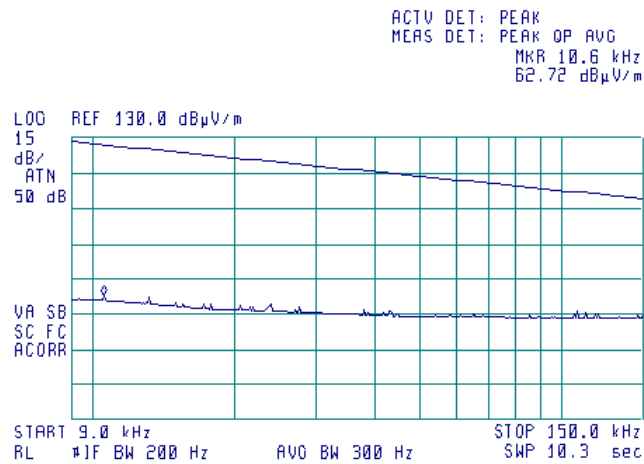

Plot 7.7.5 Radiated emission measurements from 0.15 to 30 MHz at the low, mid and high carrier frequency

TEST SITE: Semi anechoic chamber
TEST DISTANCE: 3 m
ANTENNA POLARIZATION: Vertical

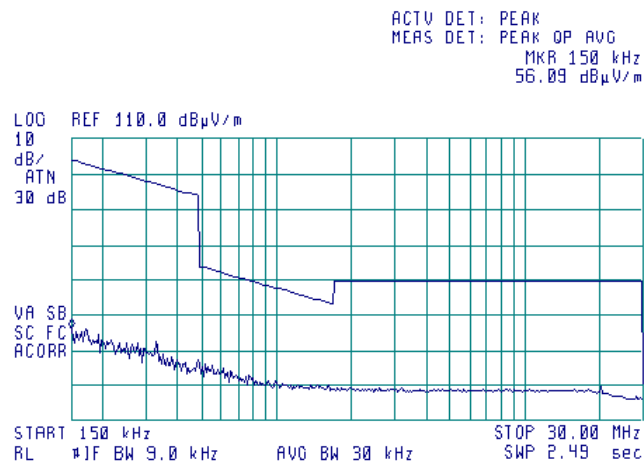

Test specification: Section 15.247(d), Radiated spurious emissions			
Test procedure: Public notice DA 00-705/ 47 CFR, Section 15.247(c) / ANSI C63.4, Section 13.1.4			
Test mode: Compliance	Verdict: PASS		
Date: 12/20/2010			
Temperature: 23 °C	Air Pressure: 1018 hPa	Relative Humidity: 50 %	Power Supply: 120 VAC
Remarks:			

Plot 7.7.6 Radiated emission measurements from 30 to 902 MHz at the low carrier frequency

TEST SITE: Semi anechoic chamber
TEST DISTANCE: 3 m
ANTENNA POLARIZATION: Vertical and Horizontal

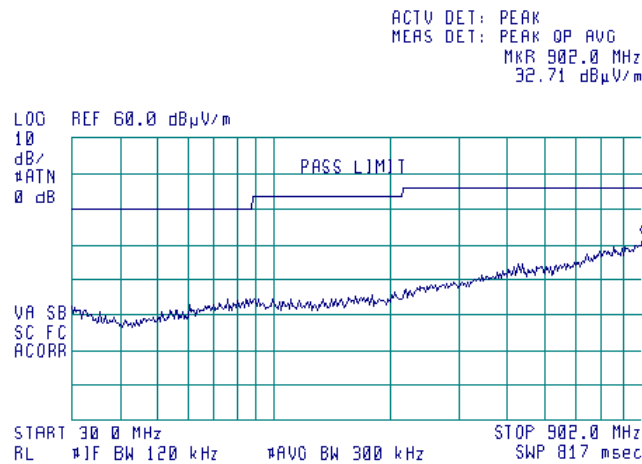

Plot 7.7.7 Radiated emission measurements from 928 to 1000 MHz at the low carrier frequency

TEST SITE: Semi anechoic chamber
TEST DISTANCE: 3 m
ANTENNA POLARIZATION: Vertical and Horizontal

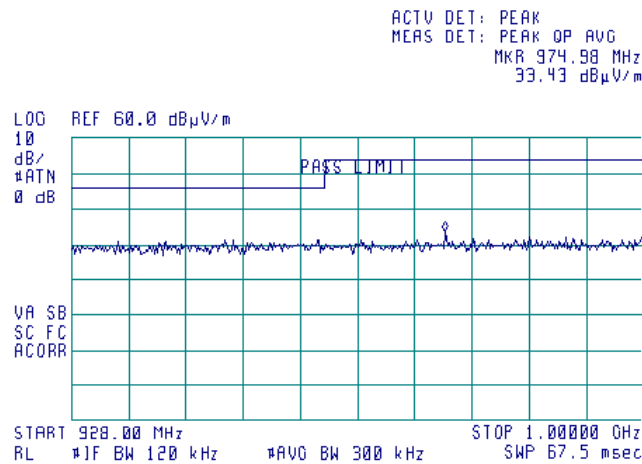

Test specification: Section 15.247(d), Radiated spurious emissions			
Test procedure: Public notice DA 00-705/ 47 CFR, Section 15.247(c) / ANSI C63.4, Section 13.1.4			
Test mode: Compliance	Verdict: PASS		
Date: 12/20/2010			
Temperature: 23 °C	Air Pressure: 1018 hPa	Relative Humidity: 50 %	Power Supply: 120 VAC
Remarks:			

Plot 7.7.8 Radiated emission measurements from 30 to 902 MHz at the mid carrier frequency

TEST SITE: Semi anechoic chamber
TEST DISTANCE: 3 m
ANTENNA POLARIZATION: Vertical and Horizontal

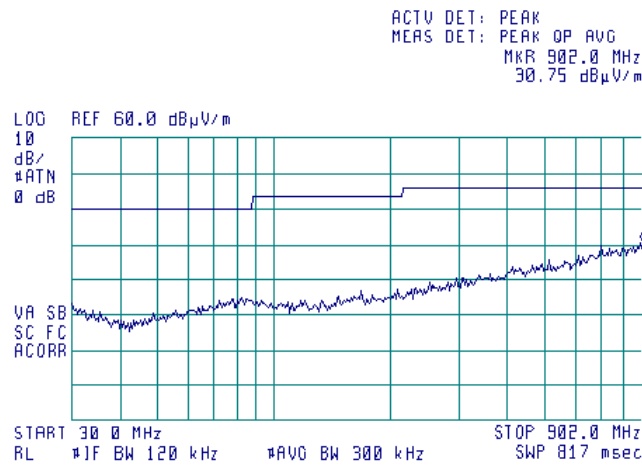

Plot 7.7.9 Radiated emission measurements from 928 to 1000 MHz at the mid carrier frequency

TEST SITE: Semi anechoic chamber
TEST DISTANCE: 3 m
ANTENNA POLARIZATION: Vertical and Horizontal

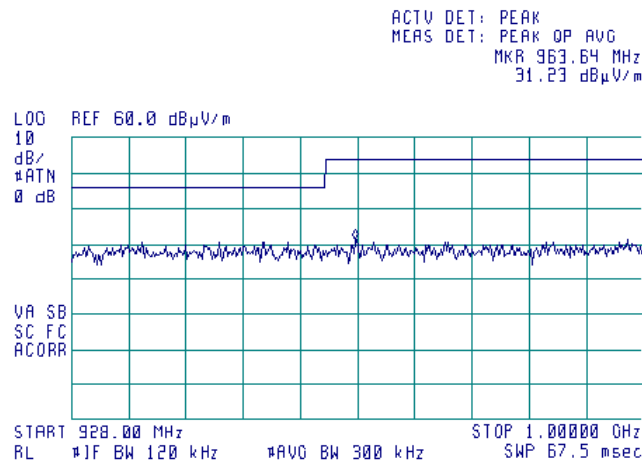

Test specification: Section 15.247(d), Radiated spurious emissions			
Test procedure: Public notice DA 00-705/ 47 CFR, Section 15.247(c) / ANSI C63.4, Section 13.1.4			
Test mode: Compliance	Verdict: PASS		
Date: 12/20/2010			
Temperature: 23 °C	Air Pressure: 1018 hPa	Relative Humidity: 50 %	Power Supply: 120 VAC
Remarks:			

Plot 7.7.10 Radiated emission measurements from 30 to 902 MHz at the high carrier frequency

TEST SITE: Semi anechoic chamber
TEST DISTANCE: 3 m
ANTENNA POLARIZATION: Vertical and Horizontal

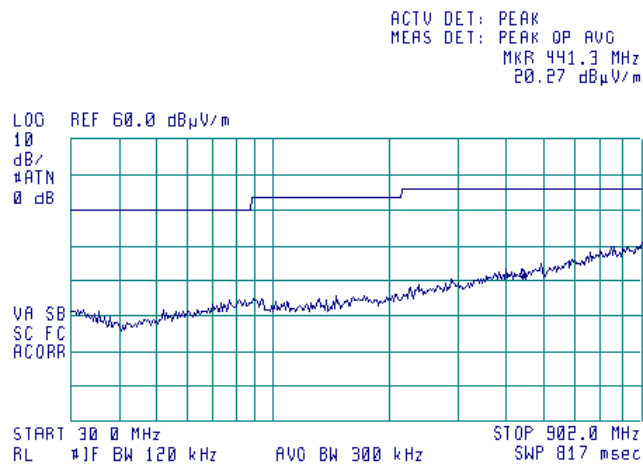

Plot 7.7.11 Radiated emission measurements from 928 to 1000 MHz at the high carrier frequency

TEST SITE: Semi anechoic chamber
TEST DISTANCE: 3 m
ANTENNA POLARIZATION: Vertical and Horizontal

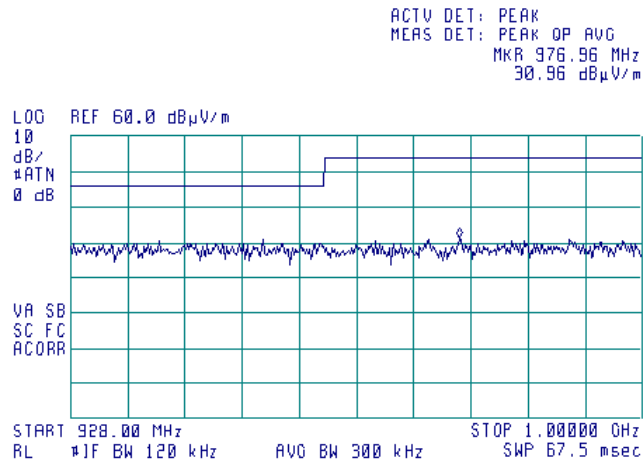

Test specification: Section 15.247(d), Radiated spurious emissions			
Test procedure: Public notice DA 00-705/ 47 CFR, Section 15.247(c) / ANSI C63.4, Section 13.1.4			
Test mode: Compliance	Verdict: PASS		
Date: 12/20/2010			
Temperature: 23 °C	Air Pressure: 1018 hPa	Relative Humidity: 50 %	Power Supply: 120 VAC
Remarks:			

Plot 7.7.12 Radiated emission measurements from 1000 to 6000 MHz at the low carrier frequency

TEST SITE: Semi anechoic chamber
TEST DISTANCE: 3 m
ANTENNA POLARIZATION: Vertical and Horizontal

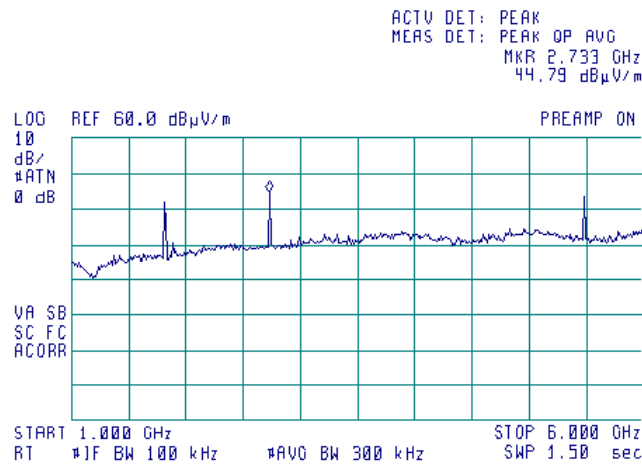

Plot 7.7.13 Radiated emission measurements from 1000 to 6000 MHz at the mid carrier frequency

TEST SITE: Semi anechoic chamber
TEST DISTANCE: 3 m
ANTENNA POLARIZATION: Vertical and Horizontal

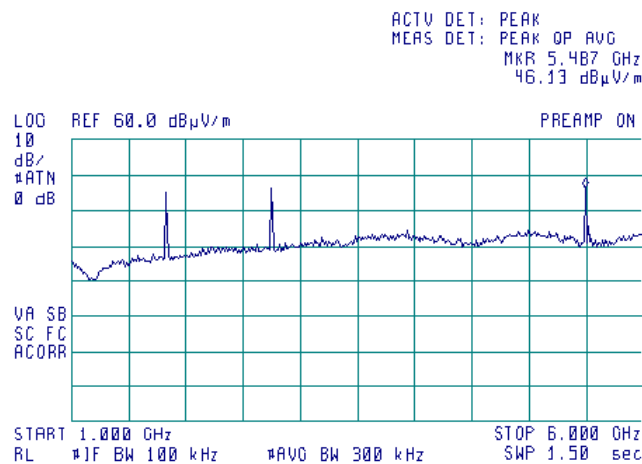

Test specification: Section 15.247(d), Radiated spurious emissions			
Test procedure: Public notice DA 00-705/ 47 CFR, Section 15.247(c) / ANSI C63.4, Section 13.1.4			
Test mode: Compliance	Verdict: PASS		
Date: 12/20/2010			
Temperature: 23 °C	Air Pressure: 1018 hPa	Relative Humidity: 50 %	Power Supply: 120 VAC
Remarks:			

Plot 7.7.14 Radiated emission measurements from 1000 to 6000 MHz at the high carrier frequency

TEST SITE: Semi anechoic chamber
TEST DISTANCE: 3 m
ANTENNA POLARIZATION: Vertical and Horizontal

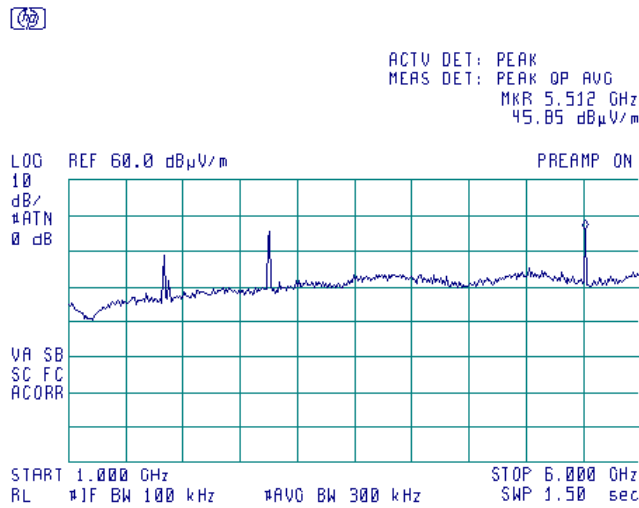

Plot 7.7.15 Radiated emission measurements from 6000 to 9200 MHz at the low carrier frequency

TEST SITE: Semi anechoic chamber
TEST DISTANCE: 3 m
ANTENNA POLARIZATION: Vertical and Horizontal

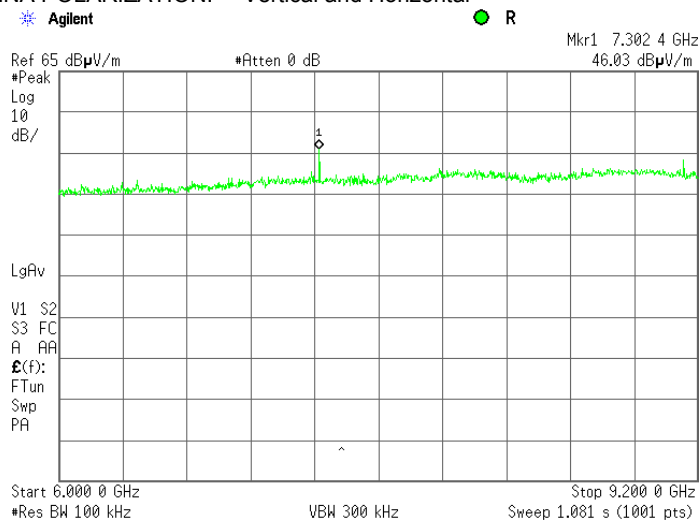

Test specification: Section 15.247(d), Radiated spurious emissions			
Test procedure: Public notice DA 00-705/ 47 CFR, Section 15.247(c) / ANSI C63.4, Section 13.1.4			
Test mode: Compliance	Verdict: PASS		
Date: 12/20/2010			
Temperature: 23 °C	Air Pressure: 1018 hPa	Relative Humidity: 50 %	Power Supply: 120 VAC
Remarks:			

Plot 7.7.16 Radiated emission measurements from 6000 to 9200 MHz at the mid carrier frequency

TEST SITE: Semi anechoic chamber
TEST DISTANCE: 3 m
ANTENNA POLARIZATION: Vertical and Horizontal

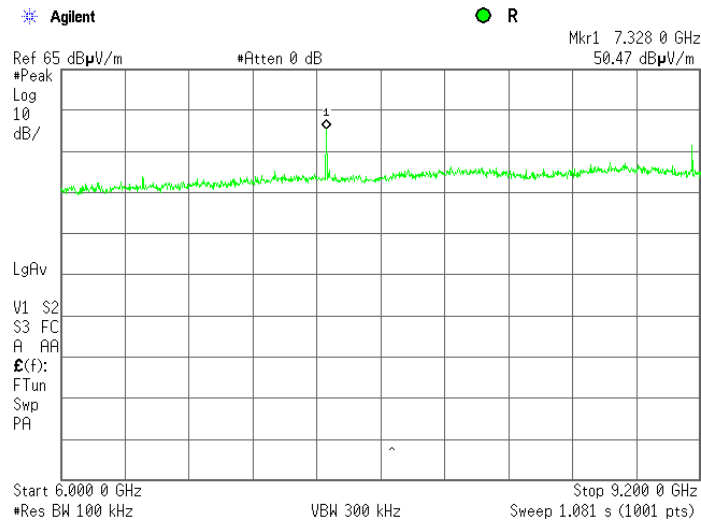

Plot 7.7.17 Radiated emission measurements from 6000 to 9300 MHz at the high carrier frequency

TEST SITE: Semi anechoic chamber
TEST DISTANCE: 3 m
ANTENNA POLARIZATION: Vertical and Horizontal

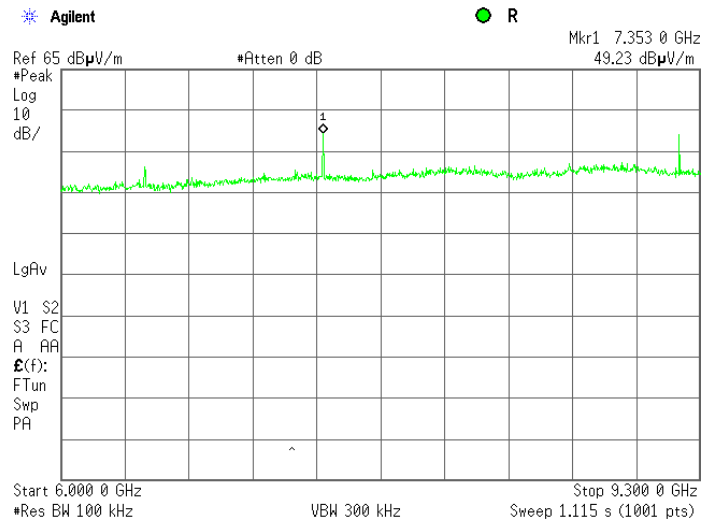

Test specification: Section 15.247(d), Radiated spurious emissions			
Test procedure: Public notice DA 00-705/ 47 CFR, Section 15.247(c) / ANSI C63.4, Section 13.1.4			
Test mode: Compliance	Verdict: PASS		
Date: 12/20/2010			
Temperature: 23 °C	Air Pressure: 1018 hPa	Relative Humidity: 50 %	Power Supply: 120 VAC
Remarks:			

Plot 7.7.18 Radiated emission measurements at the second harmonic of low carrier frequency

TEST SITE: Semi anechoic chamber
TEST DISTANCE: 3 m
ANTENNA POLARIZATION: Vertical & Horizontal

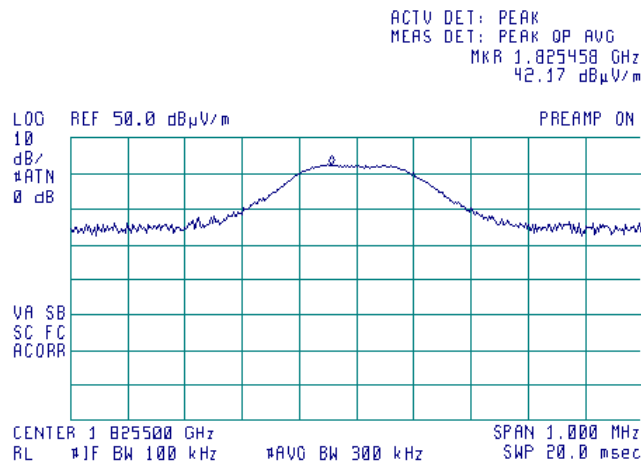

Plot 7.7.19 Radiated emission measurements at the second harmonic of mid carrier frequency

TEST SITE: Semi anechoic chamber
TEST DISTANCE: 3 m
ANTENNA POLARIZATION: Vertical & Horizontal

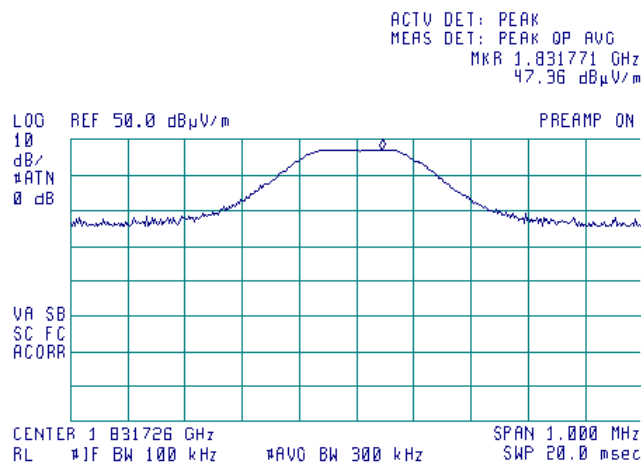



HERMON LABORATORIES

Test specification:	Section 15.247(d), Radiated spurious emissions		
Test procedure:	Public notice DA 00-705/ 47 CFR, Section 15.247(c) / ANSI C63.4, Section 13.1.4		
Test mode:	Compliance	Verdict:	PASS
Date:	12/20/2010		
Temperature: 23 °C	Air Pressure: 1018 hPa	Relative Humidity: 50 %	Power Supply: 120 VAC
Remarks:			

Plot 7.7.20 Radiated emission measurements at the second harmonic of high carrier frequency

TEST SITE: Semi anechoic chamber
 TEST DISTANCE: 3 m
 ANTENNA POLARIZATION: Vertical & Horizontal

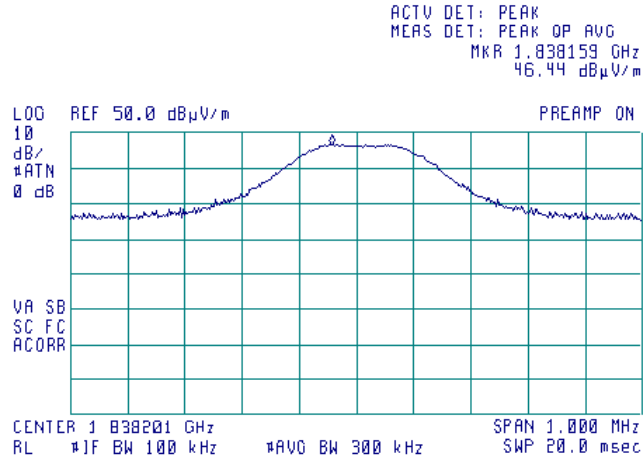

Test specification: Section 15.247(d), Radiated spurious emissions			
Test procedure: Public notice DA 00-705/ 47 CFR, Section 15.247(c) / ANSI C63.4, Section 13.1.4			
Test mode: Compliance	Verdict: PASS		
Date: 12/20/2010			
Temperature: 23 °C	Air Pressure: 1018 hPa	Relative Humidity: 50 %	Power Supply: 120 VAC
Remarks:			

Plot 7.7.21 Radiated emission measurements at the third harmonic of low carrier frequency

TEST SITE: OATS
TEST DISTANCE: 3 m
ANTENNA POLARIZATION: Vertical & Horizontal

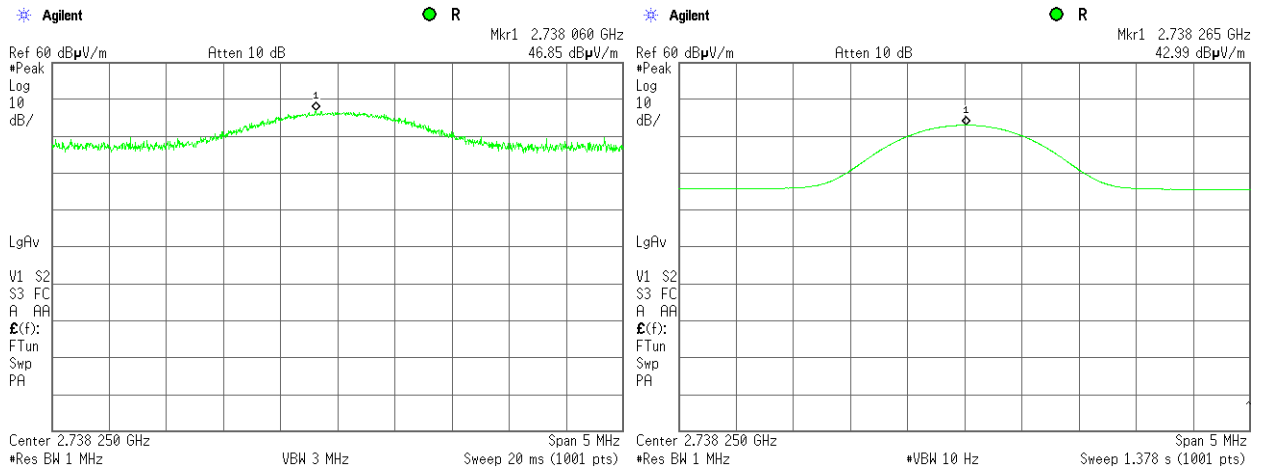

Plot 7.7.22 Radiated emission measurements at the third harmonic of mid carrier frequency

TEST SITE: OATS
TEST DISTANCE: 3 m
ANTENNA POLARIZATION: Vertical & Horizontal

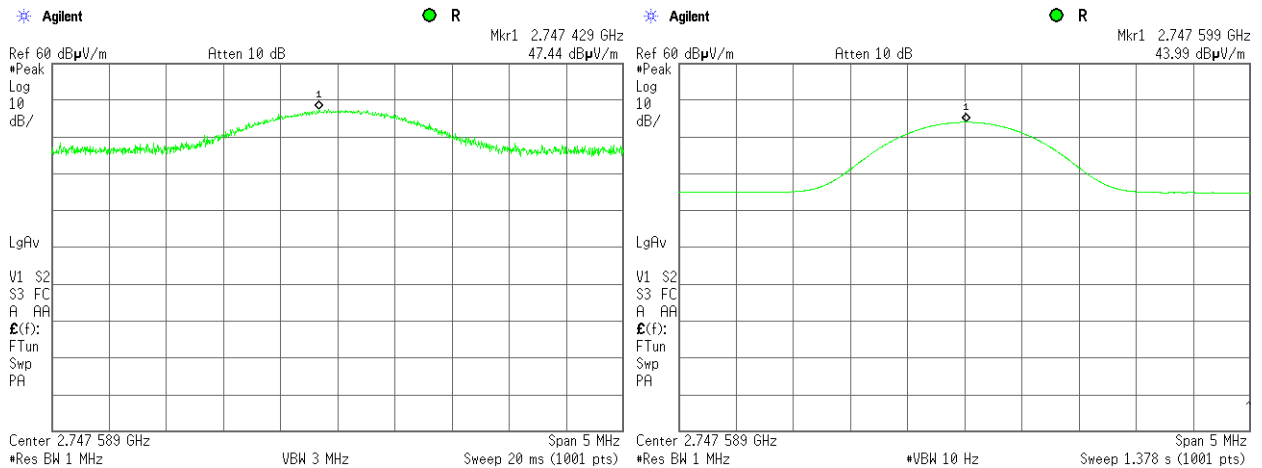

Test specification: Section 15.247(d), Radiated spurious emissions			
Test procedure: Public notice DA 00-705/ 47 CFR, Section 15.247(c) / ANSI C63.4, Section 13.1.4			
Test mode: Compliance	Verdict: PASS		
Date: 12/20/2010			
Temperature: 23 °C	Air Pressure: 1018 hPa	Relative Humidity: 50 %	Power Supply: 120 VAC
Remarks:			

Plot 7.7.23 Radiated emission measurements at the third harmonic of high carrier frequency

TEST SITE: OATS
TEST DISTANCE: 3 m
ANTENNA POLARIZATION: Vertical & Horizontal

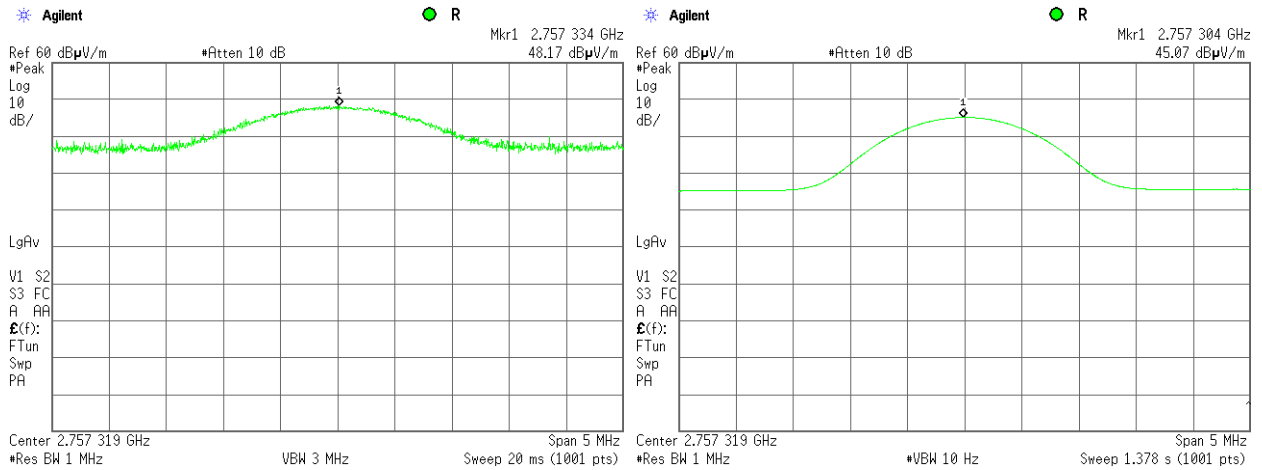

Plot 7.7.24 Radiated emission measurements at the sixth harmonic of low carrier frequency

TEST SITE: OATS
TEST DISTANCE: 3 m
ANTENNA POLARIZATION: Vertical & Horizontal

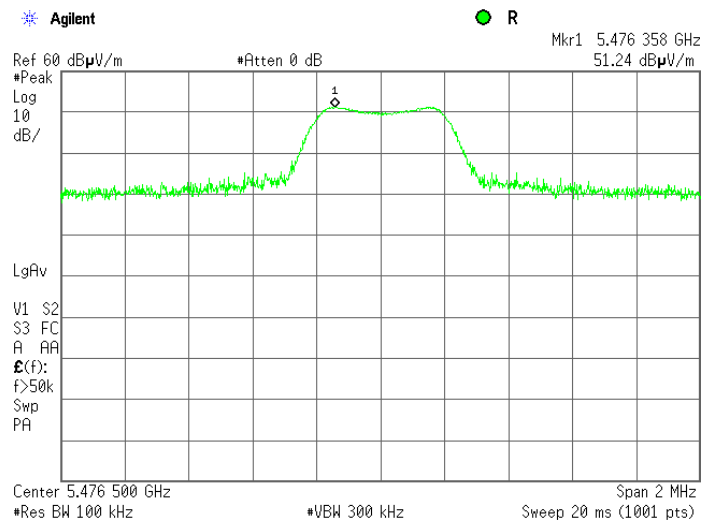

Test specification:	Section 15.247(d), Radiated spurious emissions		
Test procedure:	Public notice DA 00-705/ 47 CFR, Section 15.247(c) / ANSI C63.4, Section 13.1.4		
Test mode:	Compliance	Verdict:	PASS
Date:	12/20/2010		
Temperature: 23 °C	Air Pressure: 1018 hPa	Relative Humidity: 50 %	Power Supply: 120 VAC
Remarks:			

Plot 7.7.25 Radiated emission measurements at the sixth harmonic of mid carrier frequency

TEST SITE: OATS
TEST DISTANCE: 3 m
ANTENNA POLARIZATION: Vertical & Horizontal

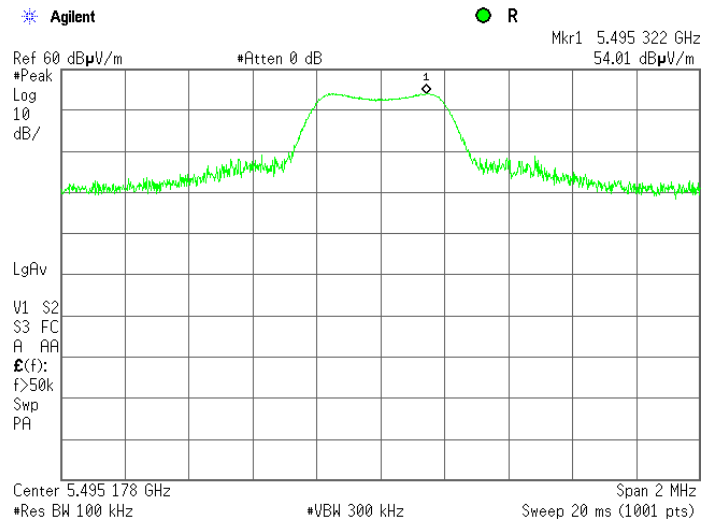

Plot 7.7.26 Radiated emission measurements at the sixth harmonic of high carrier frequency

TEST SITE: OATS
TEST DISTANCE: 3 m
ANTENNA POLARIZATION: Vertical & Horizontal

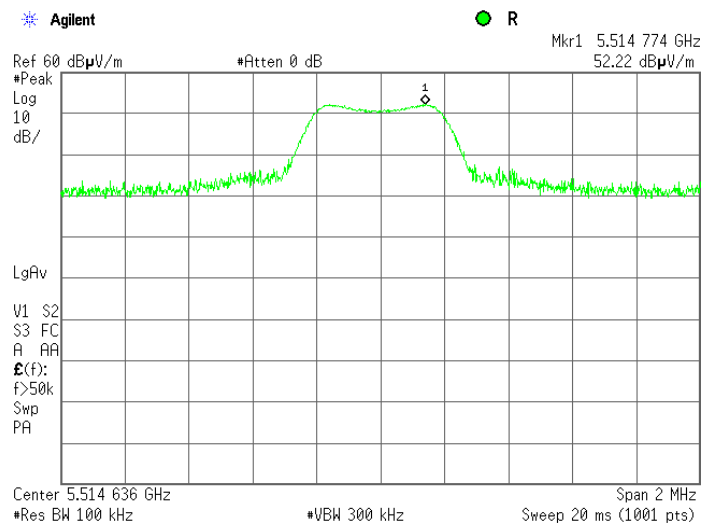

Test specification:	Section 15.247(d), Radiated spurious emissions		
Test procedure:	Public notice DA 00-705/ 47 CFR, Section 15.247(c) / ANSI C63.4, Section 13.1.4		
Test mode:	Compliance	Verdict: PASS	
Date:	12/20/2010		
Temperature: 23 °C	Air Pressure: 1018 hPa	Relative Humidity: 50 %	Power Supply: 120 VAC
Remarks:			

Plot 7.7.27 Radiated emission measurements at the seventh harmonic of low carrier frequency

TEST SITE: OATS
TEST DISTANCE: 3 m
ANTENNA POLARIZATION: Vertical & Horizontal

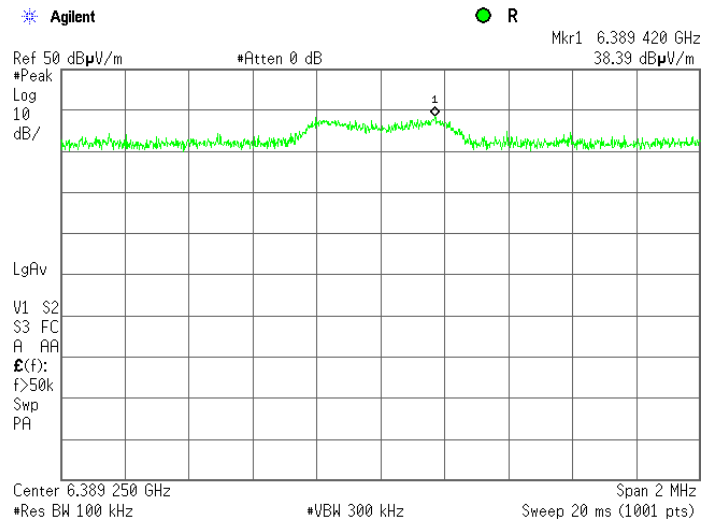

Plot 7.7.28 Radiated emission measurements at the seventh harmonic of mid carrier frequency

TEST SITE: OATS
TEST DISTANCE: 3 m
ANTENNA POLARIZATION: Vertical & Horizontal

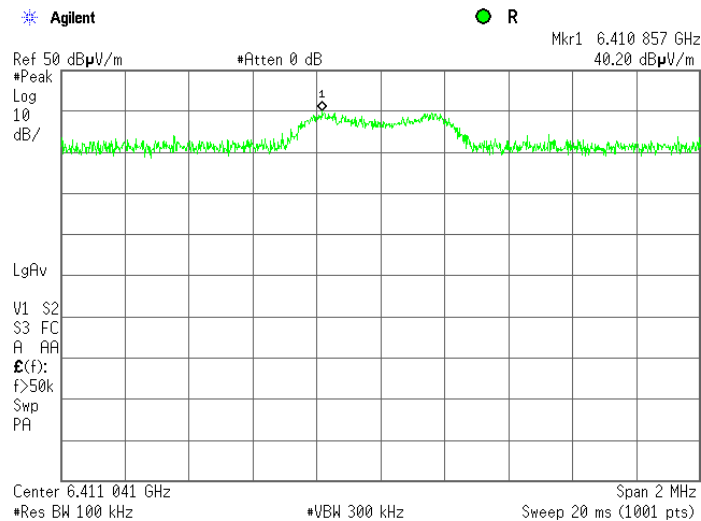

Test specification: Section 15.247(d), Radiated spurious emissions			
Test procedure: Public notice DA 00-705/ 47 CFR, Section 15.247(c) / ANSI C63.4, Section 13.1.4			
Test mode: Compliance	Verdict: PASS		
Date: 12/20/2010			
Temperature: 23 °C	Air Pressure: 1018 hPa	Relative Humidity: 50 %	Power Supply: 120 VAC
Remarks:			

Plot 7.7.29 Radiated emission measurements at the seventh harmonic of high carrier frequency

TEST SITE: OATS
TEST DISTANCE: 3 m
ANTENNA POLARIZATION: Vertical & Horizontal

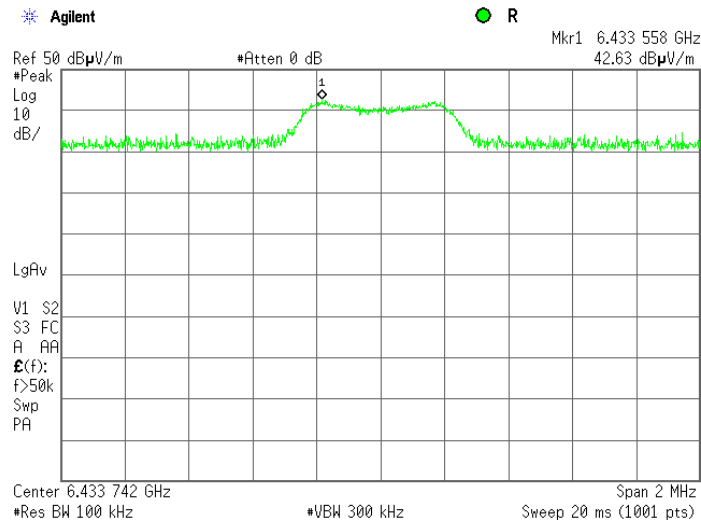

Plot 7.7.30 Radiated emission measurements at the eighth harmonic of low carrier frequency

TEST SITE: OATS
TEST DISTANCE: 3 m
ANTENNA POLARIZATION: Vertical & Horizontal

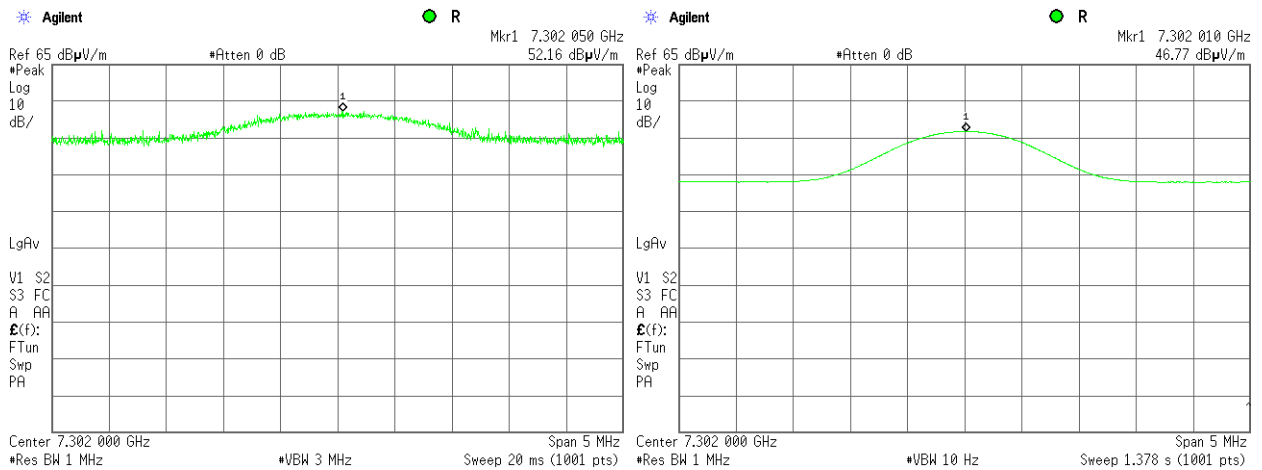

Test specification: Section 15.247(d), Radiated spurious emissions			
Test procedure: Public notice DA 00-705/ 47 CFR, Section 15.247(c) / ANSI C63.4, Section 13.1.4			
Test mode: Compliance	Verdict: PASS		
Date: 12/20/2010			
Temperature: 23 °C	Air Pressure: 1018 hPa	Relative Humidity: 50 %	Power Supply: 120 VAC
Remarks:			

Plot 7.7.31 Radiated emission measurements at the eighth harmonic of mid carrier frequency

TEST SITE: OATS
TEST DISTANCE: 3 m
ANTENNA POLARIZATION: Vertical & Horizontal

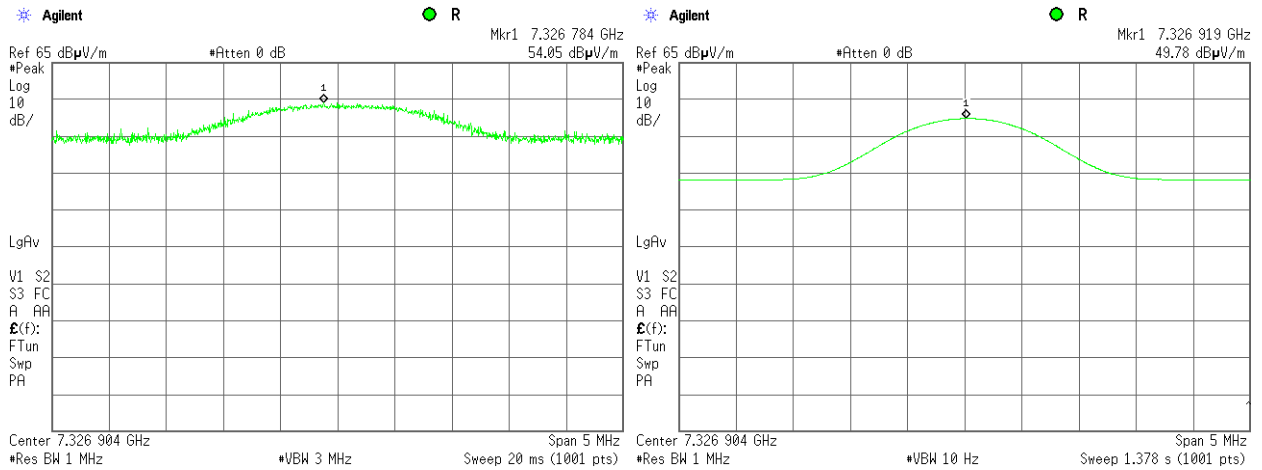

Plot 7.7.32 Radiated emission measurements at the eighth harmonic of high carrier frequency

TEST SITE: OATS
TEST DISTANCE: 3 m
ANTENNA POLARIZATION: Vertical & Horizontal

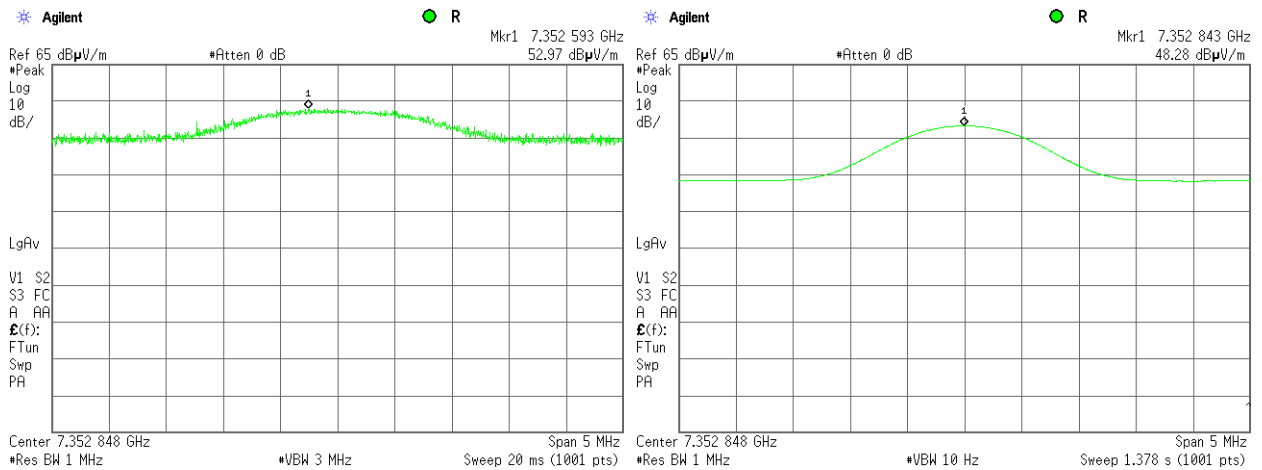

Test specification: Section 15.247(d), Radiated spurious emissions			
Test procedure: Public notice DA 00-705/ 47 CFR, Section 15.247(c) / ANSI C63.4, Section 13.1.4			
Test mode: Compliance	Verdict: PASS		
Date: 12/20/2010			
Temperature: 23 °C	Air Pressure: 1018 hPa	Relative Humidity: 50 %	Power Supply: 120 VAC
Remarks:			

Plot 7.7.33 Radiated emission measurements at the tenth harmonic of low carrier frequency

TEST SITE: OATS
TEST DISTANCE: 3 m
ANTENNA POLARIZATION: Vertical & Horizontal

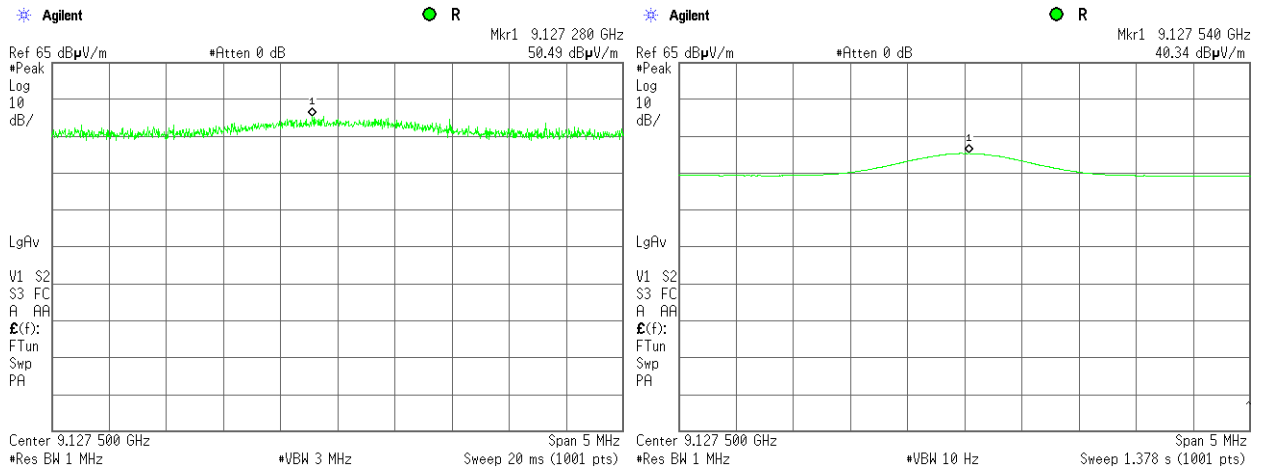

Plot 7.7.34 Radiated emission measurements at the tenth harmonic of mid carrier frequency

TEST SITE: OATS
TEST DISTANCE: 3 m
ANTENNA POLARIZATION: Vertical & Horizontal

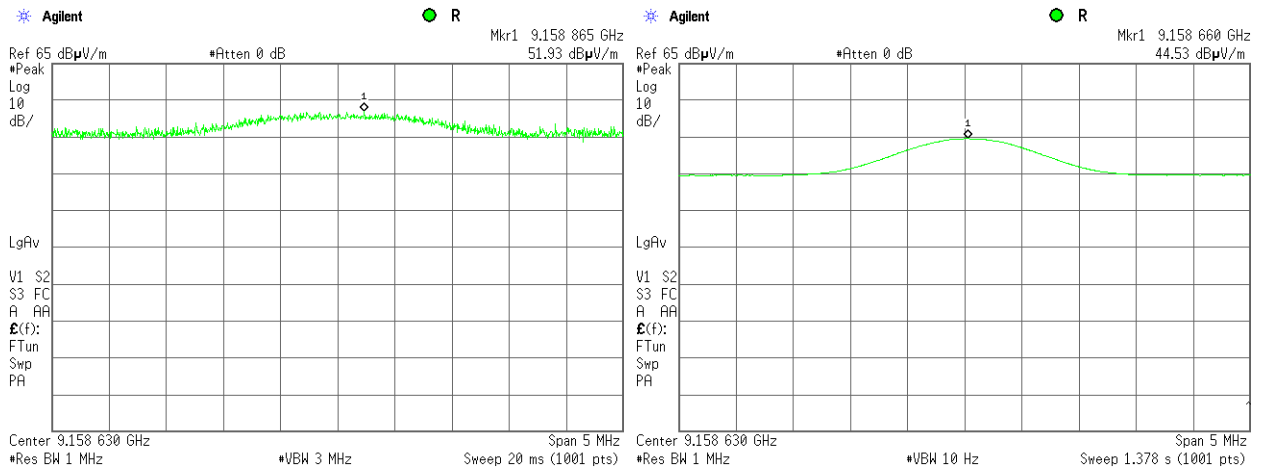



HERMON LABORATORIES

Test specification: Section 15.247(d), Radiated spurious emissions			
Test procedure: Public notice DA 00-705/ 47 CFR, Section 15.247(c) / ANSI C63.4, Section 13.1.4			
Test mode: Compliance	Verdict: PASS		
Date: 12/20/2010			
Temperature: 23 °C	Air Pressure: 1018 hPa	Relative Humidity: 50 %	Power Supply: 120 VAC
Remarks:			

Plot 7.7.35 Radiated emission measurements at the tenth harmonic of high carrier frequency

TEST SITE: OATS
TEST DISTANCE: 3 m
ANTENNA POLARIZATION: Vertical & Horizontal

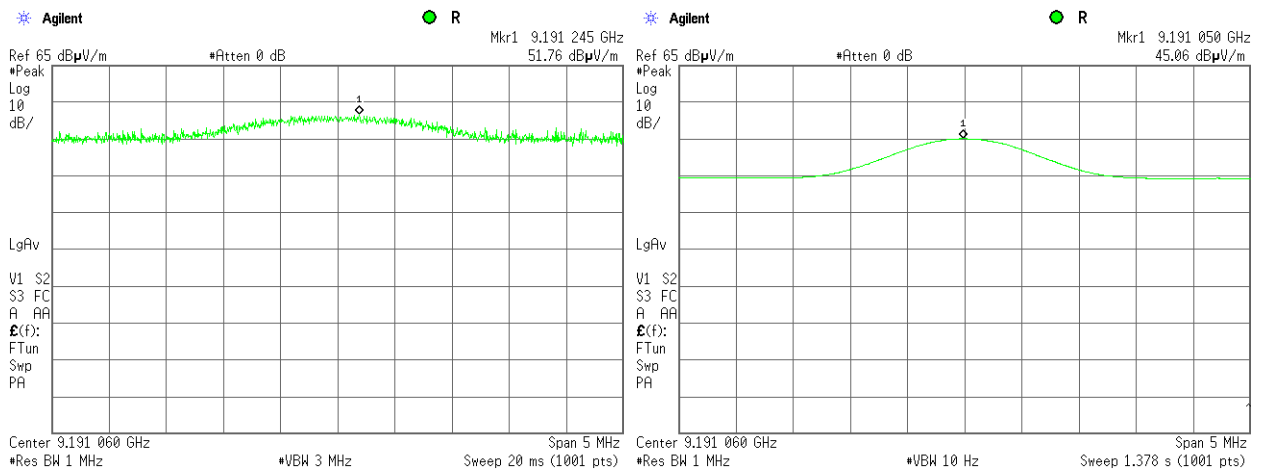

Test specification:	Section 15.203, Antenna requirements		
Test procedure:	Public notice DA 00-705		
Test mode:	Compliance	Verdict:	PASS
Date:	12/13/2010		
Temperature: 25 °C	Air Pressure: 1018 hPa	Relative Humidity: 38 %	Power Supply: 120 VAC
Remarks:			

7.8 Antenna requirements

The EUT was verified for compliance with antenna requirements. A transmitter shall be designed to ensure that no antenna other than that furnished by the responsible party will be used with the device. It may be either permanently attached or employs a unique antenna connector for every antenna proposed for use with the EUT. This requirement does not apply to professionally installed transmitters.

The rationale for compliance with the above requirements was either visual inspection results or supplier declaration. The summary of results is provided in Table 7.8.1.

Table 7.8.1 Antenna requirements

Requirement	Rationale	Verdict
The transmitter antenna is permanently attached	Visual inspection	Comply
The transmitter employs a unique antenna connector	NA	
The transmitter requires professional installation	NA	

Test specification: Section 15.207(a), Conducted emission			
Test procedure: ANSI C63.4, Section 13.1.3			
Test mode: Compliance	Verdict: PASS		
Date: 12/28/2010			
Temperature: 23.6°C	Air Pressure: 1015 hPa	Relative Humidity: 32 %	Power Supply: 120 VAC
Remarks:			

7.9 Conducted emissions

7.9.1 General

This test was performed to measure the common mode conducted emissions at the EUT power port. The specification test limits are given in Table 7.9.1.

Table 7.9.1 Limits for conducted emissions

Frequency, MHz	Class B limit, dB(μV)	
	QP	AVRG
0.15 - 0.5	66 - 56*	56 - 46*
0.5 - 5.0	56	46
5.0 - 30	60	50

* - The limit decreases linearly with the logarithm of frequency.

7.9.2 Test procedure

- 7.9.2.1 The EUT was set up as shown in Figure 7.9.1, energized and the EUT performance was checked.
- 7.9.2.2 The measurements were performed at the EUT power terminals with the LISN connected to the EMI receiver in the frequency range referred to in Table 7.9.2. The unused coaxial connector of the LISN was terminated with 50 Ohm.
- 7.9.2.3 The position of the EUT cables was varied to find the highest emission.
- 7.9.2.4 The worst test results with respect to the limits were recorded in Table 7.9.2 and shown in the associated plots.

Figure 7.9.1 Setup for conducted emission measurements, table-top EUT

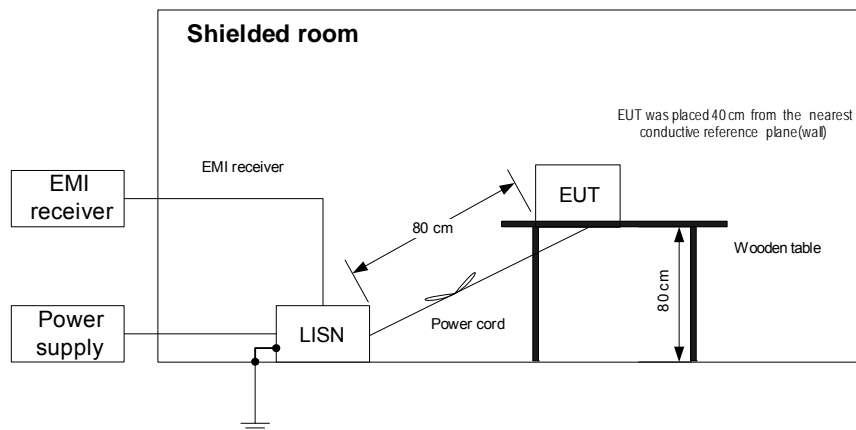



HERMON LABORATORIES

Test specification:		Section 15.207(a), Conducted emission	
Test procedure:		ANSI C63.4, Section 13.1.3	
Test mode:	Compliance	Verdict:	PASS
Date:	12/28/2010		
Temperature: 23.6°C	Air Pressure: 1015 hPa	Relative Humidity: 32 %	Power Supply: 120 VAC
Remarks:			

Table 7.9.2 Conducted emission test results

LINE: AC mains
 EUT SET UP: TABLE-TOP
 TEST SITE: SHIELDED ROOM
 DETECTORS USED: PEAK / QUASI-PEAK / AVERAGE
 FREQUENCY RANGE: 150 kHz - 30 MHz
 RESOLUTION BANDWIDTH: 9 kHz

Frequency, MHz	Peak emission, dB(μV)	Quasi-peak			Average			Line ID	Verdict
		Measured emission, dB(μV)	Limit, dB(μV)	Margin, dB*	Measured emission, dB(μV)	Limit, dB(μV)	Margin, dB*		
1.034590	34.47	24.48	56.00	-31.52	14.04	46.00	-31.96	L1	Pass
1.175228	25.02	20.36	56.00	-35.64	11.55	46.00	-34.45		
1.030595	33.24	27.00	56.00	-29.00	17.42	46.00	-28.58	L2	Pass
1.457873	27.54	23.59	56.00	-32.41	11.01	46.00	-34.99		

*- Margin = Measured emission - specification limit.

Reference numbers of test equipment used

HL 0787	HL 1205	HL 1425	HL 1513	HL 2888	HL 3612		
---------	---------	---------	---------	---------	---------	--	--

Full description is given in Appendix A.

Test specification: Section 15.207(a), Conducted emission			
Test procedure: ANSI C63.4, Section 13.1.3			
Test mode: Compliance	Verdict: PASS		
Date: 12/28/2010			
Temperature: 23.6°C	Air Pressure: 1015 hPa	Relative Humidity: 32 %	Power Supply: 120 VAC
Remarks:			

Plot 7.9.1 Conducted emission measurements

LINE: L1
EUT OPERATING MODE: Transmit
LIMIT: QUASI-PEAK, AVERAGE
DETECTOR: PEAK



ACTV DET: PEAK
MEAS DET: PEAK OP AVG
MKR 1.03 MHz
26.82 dBμV

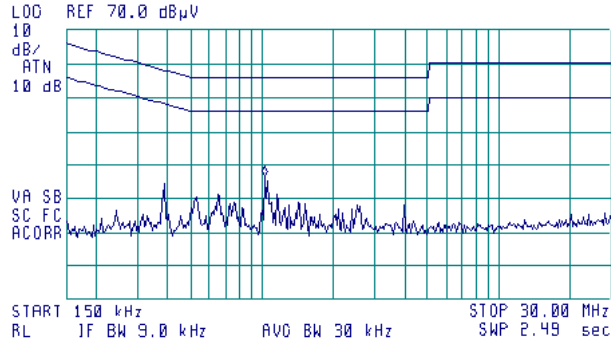

Plot 7.9.2 Conducted emission measurements

LINE: L2
EUT OPERATING MODE: Transmit
LIMIT: QUASI-PEAK, AVERAGE
DETECTOR: PEAK



ACTV DET: PEAK
MEAS DET: PEAK OP AVG
MKR 1.03 MHz
26.94 dBμV

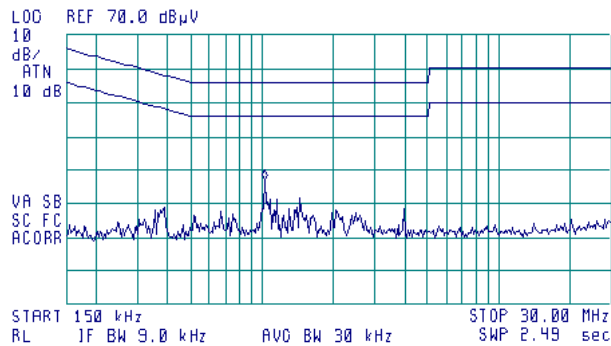

8 APPENDIX A Test equipment and ancillaries used for tests

HL No	Description	Manufacturer	Model	Ser. No.	Last Cal./ Check	Due Cal./ Check
0446	Antenna, Loop, Active, 10 kHz - 30 MHz	EMCO	6502	2857	29-Jun-10	29-Jun-11
0521	EMI Receiver (Spectrum Analyzer) with RF filter section 9 kHz-6.5 GHz	Hewlett Packard	8546A	3617A 00319, 3448A002 53	25-Aug-10	25-Aug-11
0604	Antenna BiconiLog Log-Periodic/T Bow-TIE, 26 - 2000 MHz	EMCO	3141	9611-1011	11-Jan-10	11-Jan-11
0787	Transient Limiter 9 kHz-200 MHz	Hewlett Packard	11947A	3107A018 77	18-Oct-10	18-Oct-11
1205	One phase voltage regulator, 2kVA, 0-250V	Hermon Laboratories	TDGC-2	109	18-Jul-10	18-Jul-11
1425	EMI Receiver, 9 kHz - 2.9 GHz	Agilent Technologies	8542E	3710A002 22, 3705A002 04	24-Aug-10	24-Aug-11
1431	Receiver RF Section, 9 kHz-2.9 GHz, part of HL1430 system	Agilent Technologies	85422E	308070026 2	25-Nov-10	25-Nov-11
1513	Cable RF, 8 m, BNC/BNC	Belden	M17/167 MIL-C-17	1513	01-Sep-10	01-Sep-11
1984	Antenna, Double-Ridged Waveguide Horn, 1-18 GHz, 300 W	EMC Test Systems	3115	9911-5964	11-Jun-10	11-Jun-11
2432	Antenna, Double-Ridged Waveguide Horn 1-18 GHz	EMC Test Systems	3115	00027177	11-Jun-10	11-Jun-11
2780	EMC analyzer, 100 Hz to 26.5 GHz	Agilent Technologies	E7405A	MY451024 62	07-Jul-10	07-Jul-11
2871	Microwave Cable Assembly, 18 GHz, 6.4 m, SMA - SMA	Huber-Suhner	198-8155- 00	2871	14-Sep-10	14-Sep-11
2883	Cable, 18 GHz N-type, M-F, 3 m	Bird Electronic Corp.	TC- MNFN-3.0	211539 003	01-Dec-10	01-Dec-11
2888	LISN Two-line V-Network 50 Ohm / 50 uH + 5 Ohm, 16A, MIL STD 461E, CISPR 16-1	Rolf Heine	NNB- 2/16Z	02/10018	07-Jul-10	07-Jul-11
3123	Microwave Cable Assembly, 18 GHz, 5.0 m, SMA - SMA	Huber-Suhner	198-9155- 00	3123	03-Oct-10	03-Oct-11
3341	High Pass Filter, 50 Ohm, 1400 to 5000 MHz	Mini-Circuits	VHF- 1300+	NA	04-Oct-10	04-Oct-11
3343	High Pass Filter, 50 Ohm, 2650 to 6500 MHz	Mini-Circuits	VHF- 2700+	NA	04-Oct-10	04-Oct-11
3346	High Pass Filter, 50 Ohm, 5000 to 11000 MHz	Mini-Circuits	VHF- 4600+	NA	04-Oct-10	04-Oct-11
3386	Microwave Cable Assembly, 26.5 GHz, 1.0 m, N type/N type	Suhner Sucoflex	104EA	3386	25-Feb-10	25-Feb-11
3612	Cable RF, 17.5 m, N type-N type	Teldor	RG-214/U	NA	02-Dec-10	02-Dec-11
3622	Cable RF, 6.0 m, N type-N type, DC-6.5 GHz	Alpha Wire	RG 214/U	NA	27-May-10	27-May-11
3883	Preamplifier, 0.1 to 18 GHz, Gain 25 dB, N-type (f) in, N-type (m) out.	Agilent Technologies	87405C	MY470104 06	13-Jan-10	13-Jan-11
4051	Variac (Contact voltage regulator), 3kVA, 1phase, current rated 12A	Hermon Laboratories	TDGC20- 3	NA	28-Oct-10	28-Oct-11

9 APPENDIX B Measurement uncertainties

Expanded uncertainty at 95% confidence in Hermon Labs EMC measurements

Test description	Expanded uncertainty
Conducted carrier power at RF antenna connector	Below 12.4 GHz: ± 1.7 dB 12.4 GHz to 40 GHz: ± 2.3 dB
Conducted emissions at RF antenna connector	9 kHz to 2.9 GHz: ± 2.6 dB 2.9 GHz to 6.46 GHz: ± 3.5 dB 6.46 GHz to 13.2 GHz: ± 4.3 dB 13.2 GHz to 22.0 GHz: ± 5.0 dB 22.0 GHz to 26.8 GHz: ± 5.5 dB 26.8 GHz to 40.0 GHz: ± 4.8 dB
Occupied bandwidth	± 8.0 %
Duty cycle, timing (Tx ON / OFF) and average factor measurements	± 1.0 %
Conducted emissions with LISN	9 kHz to 150 kHz: ± 3.9 dB 150 kHz to 30 MHz: ± 3.8 dB
Radiated emissions at 3 m measuring distance Horizontal polarization Vertical polarization	Biconilog antenna: ± 5.3 dB Biconical antenna: ± 5.0 dB Log periodic antenna: ± 5.3 dB Double ridged horn antenna: ± 5.3 dB Biconilog antenna: ± 6.0 dB Biconical antenna: ± 5.7 dB Log periodic antenna: ± 6.0 dB Double ridged horn antenna: ± 6.0 dB

Hermon Laboratories is accredited by A2LA for calibration according to present requirements of ISO/IEC 17025 and NCSL Z540-1. The accreditation is granted to perform calibration of parameters that are listed in the Scope of Hermon Laboratories Accreditation.

Hermon Laboratories calibrates its reference and transfer standards by calibration laboratories accredited to ISO/IEC 17025 by a mutually recognized Accreditation Body or by a recognized national metrology institute. All reference and transfer standards used in the calibration system are traceable to national or international standards.

In-house calibration of all test and measurement equipment is performed on a regular basis according to Hermon Laboratories calibration procedures, manufacturer calibration/verification procedures or procedures defined in the relevant standards. The Hermon Laboratories test and measurement equipment is calibrated within the tolerances specified by the manufacturers and/or by the relevant standards.

10 APPENDIX C Test laboratory description

Tests were performed at Hermon Laboratories Ltd., which is a fully independent, private, EMC, safety, environmental and telecommunication testing facility.

Hermon Laboratories is listed by the Federal Communications Commission (USA) for all parts of Code of Federal Regulations 47 (CFR 47), Registration Numbers 90624 for OATS and 90623 for the anechoic chamber; by Industry Canada for electromagnetic emissions (file numbers IC 2186A-1 for OATS, IC 2186A-2 for anechoic chamber, IC 2186A-3 for full-anechoic chamber for RE measurements above 1 GHz), certified by VCCI, Japan (the registration numbers are R-808 for OATS, R-1082 for anechoic chamber, G-27 for full-anechoic chamber for RE measurements above 1 GHz, C-845 for conducted emissions site, T-1606 for conducted emissions at telecommunication ports), has a status of a Telefication - Listed Testing Laboratory, Certificate No. L138/00. The laboratory is accredited by American Association for Laboratory Accreditation (USA) according to ISO/IEC 17025 for electromagnetic compatibility, product safety, telecommunications testing and environmental simulation (for exact scope please refer to Certificate No. 839.01). The FCC Designation Number is US1003.

Address: P.O. Box 23, Binyamina 30500, Israel.
Telephone: +972 4628 8001
Fax: +972 4628 8277
e-mail: mail@hermonlabs.com
website: www.hermonlabs.com

Person for contact: Mr. Alex Usoskin, CEO.

11 APPENDIX D Specification references

FCC 47CFR part 15: 2009	Radio Frequency Devices
Public notice DA 00- 705: 2000	Filing and measurement guidelines for frequency hopping spread spectrum systems.
ANSI C63.2: 1996	American National Standard for Instrumentation-Electromagnetic Noise and Field Strength, 10 kHz to 40 GHz-Specifications
ANSI C63.4: 2003	American National Standard for Methods of Measurement of Radio-Noise Emissions from Low-Voltage Electrical and Electronic Equipment in the Range of 9 kHz to 40 GHz

12 APPENDIX E Test equipment correction factors

Correction factor
Line impedance stabilization network
Model NNB-2/16Z, Rolf Heine, HL 2888

Frequency, kHz	Insertion loss, dB		Measurement Uncertainty, dB
	L1	N	
10	0.48	0.79	±0.6
20	0.52	0.63	
30	0.31	0.35	
40	0.20	0.22	
50	0.16	0.17	
100	0.10	0.08	
300	0.08	0.06	
500	0.10	0.06	
600	0.09	0.07	
800	0.10	0.07	
1000	0.10	0.08	
2000	0.12	0.11	
3000	0.16	0.14	
4000	0.17	0.18	
6000	0.26	0.23	
10000	0.49	0.41	
14000	0.66	0.54	
16000	0.79	0.69	
18000	0.86	0.76	
20000	0.96	0.85	
25000	1.22	1.08	
28000	1.35	1.21	
30000	1.43	1.29	

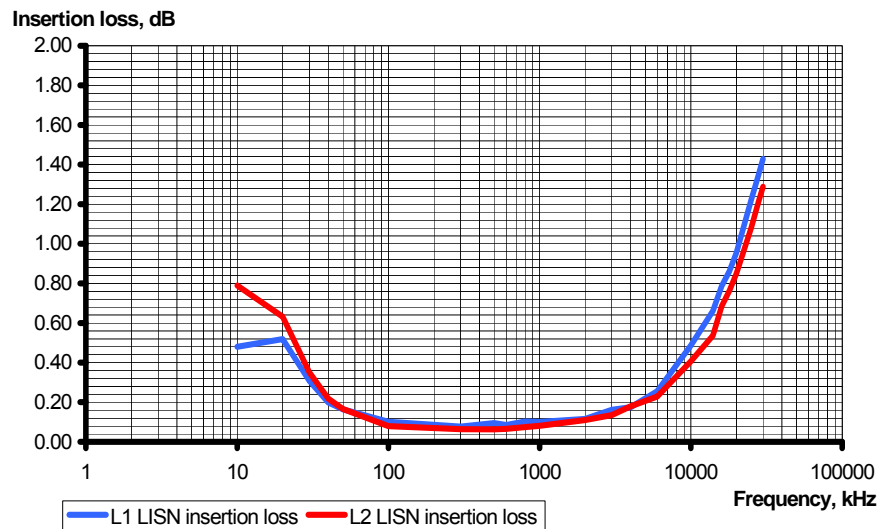

Antenna factor
Active loop antenna
Model 6502, S/N 2857, HL 0446

Frequency, MHz	Magnetic antenna factor, dB	Electric antenna factor, dB
0.009	-32.8	18.7
0.010	-33.8	17.7
0.020	-38.3	13.2
0.050	-41.1	10.4
0.075	-41.3	10.2
0.100	-41.6	9.9
0.150	-41.7	9.8
0.250	-41.6	9.9
0.500	-41.8	9.8
0.750	-41.9	9.7
1.000	-41.4	10.1
2.000	-41.5	10.0
3.000	-41.4	10.2
4.000	-41.4	10.1
5.000	-41.5	10.1
10.000	-41.9	9.6
15.000	-41.9	9.6
20.000	-42.2	9.3
25.000	-42.8	8.7
30.000	-44.0	7.5

Antenna factor in dB(1/m) is to be added to receiver meter reading in dB(μ V) to convert it into field intensity in dB(μ V/m).

Antenna factor
Biconilog antenna EMCO Model 3141
Ser.No.1011, HL 0604

Frequency, MHz	Antenna Factor, dB(1/m)	Frequency, MHz	Antenna Factor, dB(1/m)
26	7.8	940	24.0
28	7.8	960	24.1
30	7.8	980	24.5
40	7.2	1000	24.9
60	7.1	1020	25.0
70	8.5	1040	25.2
80	9.4	1060	25.4
90	9.8	1080	25.6
100	9.7	1100	25.7
110	9.3	1120	26.0
120	8.8	1140	26.4
130	8.7	1160	27.0
140	9.2	1180	27.0
150	9.8	1200	26.7
160	10.2	1220	26.5
170	10.4	1240	26.5
180	10.4	1260	26.5
190	10.3	1280	26.6
200	10.6	1300	27.0
220	11.6	1320	27.8
240	12.4	1340	28.3
260	12.8	1360	28.2
280	13.7	1380	27.9
300	14.7	1400	27.9
320	15.2	1420	27.9
340	15.4	1440	27.8
360	16.1	1460	27.8
380	16.4	1480	28.0
400	16.6	1500	28.5
420	16.7	1520	28.9
440	17.0	1540	29.6
460	17.7	1560	29.8
480	18.1	1580	29.6
500	18.5	1600	29.5
520	19.1	1620	29.3
540	19.5	1640	29.2
560	19.8	1660	29.4
580	20.6	1680	29.6
600	21.3	1700	29.8
620	21.5	1720	30.3
640	21.2	1740	30.8
660	21.4	1760	31.1
680	21.9	1780	31.0
700	22.2	1800	30.9
720	22.2	1820	30.7
740	22.1	1840	30.6
760	22.3	1860	30.6
780	22.6	1880	30.6
800	22.7	1900	30.6
820	22.9	1920	30.7
840	23.1	1940	30.9
860	23.4	1960	31.2
880	23.8	1980	31.6
900	24.1	2000	32.0
920	24.1		

Antenna factor in dB(1/m) is to be added to receiver meter reading in dB(μ V) to convert it into field intensity in dB(μ V/m).

**Antenna factor
Double-ridged wave guide horn antenna
Model 3115, S/N 9911-5964, HL1984**

Frequency, MHz	Antenna factor, dB(1/m)
1000.0	24.7
1500.0	25.7
2000.0	27.6
2500.0	28.9
3000.0	31.2
3500.0	32.0
4000.0	32.5
4500.0	32.7
5000.0	33.6
5500.0	35.1
6000.0	35.4
6500.0	34.9
7000.0	36.1
7500.0	37.8
8000.0	38.0
8500.0	38.1
9000.0	39.1
9500.0	38.3
10000.0	38.6
10500.0	38.2
11000.0	38.7
11500.0	39.5
12000.0	40.0
12500.0	40.4
13000.0	40.5
13500.0	41.1
14000.0	41.6
14500.0	41.7
15000.0	38.7
15500.0	38.2
16000.0	38.8
16500.0	40.5
17000.0	42.5
17500.0	45.9
18000.0	49.4

Antenna factor in dB(1/m) is to be added to receiver meter reading in dB(μ V) to convert it into field intensity in dB(μ V/m).

**Antenna factor
Double-ridged guide horn antenna
Model 3115, serial number: 00027177, HL 2432**

Frequency, MHz	Antenna factor. dB(1/m)
1000.0	24.7
1500.0	25.7
2000.0	27.8
2500.0	28.9
3000.0	30.7
3500.0	31.8
4000.0	33.0
4500.0	32.8
5000.0	34.2
5500.0	34.9
6000.0	35.2
6500.0	35.4
7000.0	36.3
7500.0	37.3
8000.0	37.5
8500.0	38.0
9000.0	38.3
9500.0	38.3
10000.0	38.7
10500.0	38.7
11000.0	38.9
11500.0	39.5
12000.0	39.5
12500.0	39.4
13000.0	40.5
13500.0	40.8
14000.0	41.5
14500.0	41.3
15000.0	40.2
15500.0	38.7
16000.0	38.5
16500.0	39.8
17000.0	41.9
17500.0	45.8
18000.0	49.1

Antenna factor in dB(1/m) is to be added to receiver meter reading in dB(μ V) to convert it into field intensity in dB(μ V/m).

Cable loss
Cable coaxial, Huber-Suhner, 18 GHz, 6.4 m, SMA - SMA, model 198-8155-00,
HL 2871

Frequency, MHz	Cable loss, dB	Frequency, MHz	Cable loss, dB	Frequency, MHz	Cable loss, dB
10	0.12	5750	2.34	12000	3.55
30	0.14	6000	2.39	12250	3.61
100	0.27	6250	2.46	12500	3.67
250	0.45	6500	2.52	12750	3.74
500	0.63	6750	2.58	13000	3.79
750	0.76	7000	2.64	13250	3.82
1000	0.89	7250	2.68	13500	3.83
1250	1.01	7500	2.73	13750	3.83
1500	1.12	7750	2.78	14000	3.88
1750	1.23	8000	2.83	14250	3.93
2000	1.32	8250	2.88	14500	3.96
2250	1.41	8500	2.94	14750	4.01
2500	1.49	8750	2.97	15000	4.00
2750	1.58	9000	3.02	15250	4.01
3000	1.66	9250	3.07	15500	4.00
3250	1.73	9500	3.13	15750	4.13
3500	1.80	9750	3.18	16000	4.22
3750	1.87	10000	3.21	16250	4.29
4000	1.93	10250	3.26	16500	4.29
4250	2.01	10500	3.30	16750	4.32
4500	2.06	10750	3.36	17000	4.37
4750	2.12	11000	3.39	17250	4.45
5000	2.17	11250	3.44	17500	4.49
5250	2.24	11500	3.48	17750	4.53
5500	2.29	11750	3.52	18000	4.55

Cable loss
Cable coaxial, Bird, 18 GHz, N-type, M-F, model TC-MNFN-3.0, S/N 211539 003
HL 2883

Frequency, MHz	Cable loss, dB	Frequency, MHz	Cable loss, dB	Frequency, MHz	Cable loss, dB
10	0.06	5750	1.70	12000	2.46
30	0.12	6000	1.75	12250	2.48
100	0.21	6250	1.80	12500	2.52
250	0.34	6500	1.81	12750	2.50
500	0.47	6750	1.86	13000	2.54
750	0.59	7000	1.86	13250	2.48
1000	0.67	7250	1.92	13500	2.63
1250	0.76	7500	1.96	13750	2.65
1500	0.84	7750	1.98	14000	2.72
1750	0.92	8000	2.02	14250	2.67
2000	0.98	8250	2.03	14500	2.70
2250	1.05	8500	2.05	14750	2.72
2500	1.12	8750	2.11	15000	2.79
2750	1.17	9000	2.17	15250	2.80
3000	1.22	9250	2.17	15500	2.83
3250	1.27	9500	2.20	15750	2.75
3500	1.33	9750	2.19	16000	2.82
3750	1.38	10000	2.22	16250	2.85
4000	1.42	10250	2.25	16500	2.90
4250	1.46	10500	2.30	16750	2.89
4500	1.51	10750	2.28	17000	2.88
4750	1.54	11000	2.32	17250	2.85
5000	1.59	11250	2.34	17500	2.96
5250	1.62	11500	2.39	17750	3.04
5500	1.65	11750	2.42	18000	3.04

Cable loss
Microwave Cable Assembly, 18 GHz, 6.4 m, SMA – SMA, Huber-Suhner, model 198-9155-00
HL 3123

Frequency, MHz	Cable loss, dB	Frequency, MHz	Cable loss, dB	Frequency, MHz	Cable loss, dB	Frequency, MHz	Cable loss, dB	Frequency, MHz	Cable loss, dB
10	0.11	3600	1.97	7400	3.12	11200	3.90	15100	4.74
30	0.17	3700	1.97	7500	3.13	11300	3.93	15200	4.70
50	0.25	3800	2.03	7600	3.16	11400	3.88	15300	4.73
100	0.32	3900	2.04	7700	3.18	11500	3.87	15400	4.78
200	0.46	4000	2.10	7800	3.20	11600	3.90	15500	4.75
300	0.58	4100	1.97	7900	3.23	11700	3.86	15600	4.76
400	0.65	4200	1.97	8000	3.25	11800	3.88	15700	4.75
500	0.74	4300	2.03	8100	3.26	11900	3.86	15800	4.78
600	0.82	4400	2.04	8200	3.28	12000	3.89	15900	4.79
700	0.89	4500	2.10	8300	3.31	12100	3.94	16000	4.73
800	0.95	4600	1.97	8400	3.31	12200	3.92	16100	4.78
900	1.01	4700	1.97	8500	3.32	12300	3.96	16200	4.84
1000	1.07	4800	2.03	8600	3.34	12400	4.01	16300	4.90
1100	1.11	4900	2.04	8700	3.35	12500	4.07	16400	4.87
1200	1.17	5000	2.10	8800	3.37	12600	4.08	16500	4.90
1300	1.22	5100	2.53	8900	3.39	12700	4.17	16600	4.98
1400	1.27	5200	2.55	9000	3.42	12800	4.26	16700	5.05
1500	1.29	5300	2.60	9100	3.43	12900	4.16	16800	5.04
1600	1.35	5400	2.61	9200	3.51	13000	4.21	16900	5.02
1700	1.40	5500	2.64	9300	3.52	13100	4.24	17000	5.09
1800	1.44	5600	2.70	9400	3.54	13200	4.27	17100	5.07
1900	1.51	5700	2.67	9500	3.63	13300	4.31	17200	5.10
2000	1.49	5800	2.71	9600	3.61	13400	4.33	17300	5.13
2100	1.55	5900	2.74	9700	3.71	13500	4.25	17400	5.23
2200	1.58	6000	2.80	9800	3.66	13600	4.27	17500	5.21
2300	1.62	6100	2.79	9900	3.77	13700	4.33	17600	5.22
2400	1.72	6200	2.81	10000	3.75	13800	4.33	17700	5.36
2500	1.76	6300	2.83	10100	3.77	13900	4.31	17800	5.35
2600	1.78	6400	2.86	10200	3.80	14000	4.30	17900	5.45
2700	1.80	6500	2.88	10300	3.79	14100	4.30	18000	5.43
2800	1.86	6600	2.90	10400	3.87	14200	4.31		
2900	1.90	6700	2.92	10500	3.83	14300	4.37		
3000	1.90	6800	2.98	10600	3.88	14400	4.35		
3100	1.97	6900	2.98	10700	3.86	14600	4.53		
3200	1.97	7000	3.00	10800	3.87	14700	4.50		
3300	2.03	7100	3.02	10900	3.90	14800	4.62		
3400	2.04	7200	3.04	11000	3.84	14900	4.65		
3500	2.10	7300	3.06	11100	3.88	15000	4.79		



Cable loss
Cable coaxial, Microwave Cable Assembly, 104EA, 18 GHz, 1.0 m
Suhner Sucoflex, HL 3386

Frequency, MHz	Cable loss, dB	Frequency, MHz	Cable loss, dB	Frequency, MHz	Cable loss, dB
10	0.05	5750	1.01	12000	1.29
30	0.07	6000	1.02	12250	1.33
100	0.12	6250	1.02	12500	1.36
250	0.18	6500	0.95	12750	1.35
500	0.26	6750	0.96	13000	1.36
750	0.32	7000	1.01	13250	1.39
1000	0.35	7250	1.04	13500	1.37
1250	0.41	7500	1.09	13750	1.43
1500	0.45	7750	1.12	14000	1.46
1750	0.50	8000	1.13	14250	1.39
2000	0.54	8250	1.15	14500	1.36
2250	0.57	8500	1.15	14750	1.47
2500	0.61	8750	1.15	15000	1.47
2750	0.64	9000	1.16	15250	1.41
3000	0.67	9250	1.14	15500	1.52
3250	0.70	9500	1.14	15750	1.54
3500	0.71	9750	1.19	16000	1.49
3750	0.74	10000	1.20	16250	1.48
4000	0.77	10250	1.22	16500	1.52
4250	0.80	10500	1.23	16750	1.56
4500	0.84	10750	1.22	17000	1.57
4750	0.85	11000	1.21	17250	1.53
5000	0.84	11250	1.24	17500	1.55
5250	0.85	11500	1.26	17750	1.55
5500	0.92	11750	1.28	18000	1.54

Cable loss
Cable coaxial, RG-214/U, N type-N type, 17 m
Teldor, HL 3612

Frequency, MHz	Cable loss, dB
0.1	0.05
0.5	0.07
1	0.10
3	0.22
5	0.29
10	0.39
30	0.68
50	0.90
100	1.27
150	1.58
200	1.80
250	2.12
300	2.36
350	2.60
400	2.82
450	2.99
500	3.23
550	3.40
600	3.56
650	3.71
700	3.90
750	4.04
800	4.23
850	4.39
900	4.55
950	4.65
1000	4.79

Cable loss
Cable coaxial, RG-214/U, N type-N type, 6 m
Alpha Wire, HL 3622

Frequency, MHz	Cable loss, dB	Frequency, MHz	Cable loss, dB	Frequency, MHz	Cable loss, dB
10	0.13	2100	2.95	4400	4.99
30	0.24	2200	2.99	4500	5.00
50	0.32	2300	3.11	4600	5.17
100	0.47	2400	3.16	4700	5.18
200	0.70	2500	3.31	4800	5.33
300	0.88	2600	3.36	4900	5.34
400	1.05	2700	3.46	5000	5.50
500	1.21	2800	3.52	5100	5.56
600	1.36	2900	3.65	5200	5.76
700	1.49	3000	3.70	5300	5.76
800	1.63	3100	3.82	5400	5.85
900	1.72	3200	3.88	5500	5.88
1000	1.84	3300	3.99	5600	5.96
1100	1.96	3400	4.08	5700	6.02
1200	2.06	3500	4.19	5800	6.06
1300	2.15	3600	4.28	5900	6.14
1400	2.28	3700	4.42	6000	6.17
1500	2.35	3800	4.40	6100	6.28
1600	2.43	3900	4.51	6200	6.36
1700	2.57	4000	4.62	6300	6.47
1800	2.62	4100	4.70	6400	6.51
1900	2.75	4200	4.78	6500	6.65
2000	2.80	4300	4.83		

13 APPENDIX F Abbreviations and acronyms

A	ampere
AC	alternating current
A/m	ampere per meter
AM	amplitude modulation
AVRG	average (detector)
cm	centimeter
dB	decibel
dBm	decibel referred to one milliwatt
dB(μ V)	decibel referred to one microvolt
dB(μ V/m)	decibel referred to one microvolt per meter
dB(μ A)	decibel referred to one microampere
DC	direct current
EIRP	equivalent isotropically radiated power
ERP	effective radiated power
EUT	equipment under test
F	frequency
GHz	gigahertz
GND	ground
H	height
HL	Hermon laboratories
Hz	hertz
k	kilo
kHz	kilohertz
LO	local oscillator
m	meter
MHz	megahertz
min	minute
mm	millimeter
ms	millisecond
μ s	microsecond
NA	not applicable
NB	narrow band
OATS	open area test site
Ω	Ohm
PM	pulse modulation
PS	power supply
ppm	part per million (10^{-6})
QP	quasi-peak
RE	radiated emission
RF	radio frequency
rms	root mean square
Rx	receive
s	second
T	temperature
Tx	transmit
V	volt
WB	wideband

END OF TEST REPORT

14 APPENDIX G Applicant's declaration

Declaration of Conformity

To:
Hermon labs Binyamina
Israel

15/12/2010

Attention: Mr. Alex Usoskin Mr. Michael Nikishen Ms Ella Pit

This is to confirm that the maximum continuous transmission duration, in a single channel, of a PowerG transceiver of the SR 610 (915 MHz) is limited to 42.24ms, and all the units comply with the FCC requirements down below:

§ 15.247 Operation within the bands 902–928 MHz, 2400–2483.5 MHz, and 5725–5850 MHz

(a) (1) Frequency hopping systems shall have hopping channel carrier frequencies separated by a minimum of 25 kHz or the 20 dB bandwidth of the hopping channel, whichever is greater.

(a)(1)(i) For frequency hopping systems operating in the 902–928 MHz band: if the 20 dB bandwidth of the hopping channel is less than 250 kHz, the system shall use at least 50 hopping frequencies and the average time of occupancy on any frequency shall not be greater than 0.4 seconds within a 20 second period.

Regards

 Arick Elshtein

International Standards Manager



Visonic®
For a secure way of life

Head Office
24 Habarzel Street, Tel-Aviv 69710 Israel
Postal Address: P.O.B. 22020, Tel-Aviv 61220
Tel. +972 3 645 6789 Fax. +972 3 645 6788

www.visonic.com