

PowerMaster-10 Installer Guide

TABLE OF CONTENTS

1. INTRODUCTION	4	4.4.3 Setting User Codes.....	18
PowerG Technology is easy to install and maintain	4	4.4.4 Enabling User Permit for Installer Access.....	18
2. SPECIFICATIONS.....	5	4.4.5 Configuring Permissions for System Reset after Alarm Event.....	18
Functional.....	5	4.4.6 Configuring a Duress Code	19
Wireless	6	4.5 Zones / Devices	20
Electrical	6	4.5.1 General Guidance.....	20
Communication.....	6	4.5.2 Adding a Wireless Device.....	20
Physical Properties	7	4.5.3 Adding Wired Zones.....	24
Peripherals and Accessory Devices.....	7	4.5.4 Deleting a Device.....	25
3. INSTALLATION.....	7	4.5.5 Modifying a Device	26
3.1 Choosing the Mounting Location	7	4.5.6 Replacing a Device.....	27
3.2 Mounting the Unit	8	4.5.7 Defining Defaults.....	28
Opening the Control Panel and Bracket Mounting.....	8	4.6 Siren Configuration	29
Closing the Control Panel.....	8	4.6.1 Configuring the Length of Time the Bell is allowed to Function.....	29
3.3 Supplying Power to the Unit.....	9	4.6.2 Enabling the Internal Siren	29
Inserting Backup Battery	9	4.6.3 Configuring the Period of Strobe Light Activation	30
Connecting Power to Panel.....	10	4.6.4 Enabling Siren Activation upon Telephone Line Failure	30
3.4 Connecting to the Telephone Line.....	10	4.7 Event Reporting Configuration	31
3.5 System Planning & Programming.....	12	4.7.1 General.....	31
3.6 Extension Modules GSM Installation.....	12	4.7.2 Setup Report Communicators.....	31
PowerLink Broadband Module Installation....	12	4.7.3 Configuring Event Reporting to Monitoring Station.....	34
3.7 Annual System Check	13	4.7.4 Configuring Event Reporting to Users.....	43
4. PROGRAMMING.....	14	4.8 Security System Configuration	46
4.1 General Guidance	14	4.8.1 Enable Cross Zoning.....	46
4.2 Entering the Installer Menu	14	4.8.2 Configuring Swinger Stop.....	47
Installer Mode Options Menu.....	14	4.8.3 Enable Monitoring of Activity at Home	47
Programming User Settings.....	15	4.8.4 Configuring Alarm Cancel Period	48
4.3 Navigation.....	16	4.8.5 Configuring Power Failure Threshold Period.....	48
4.4 Permissions and User Codes.....	16	4.8.6 Configuring Abort Time	49
4.4.1 Setting a New Installer Code.....	16	4.8.7 Configuring a Confirmed Alarm.....	50
4.4.2 Setting the Master Installer Code	17	4.8.8 Enable Alarm upon Detection of Jammed or Missing Device	50
		4.8.9 Configuring the Jamming Detection	51
		4.8.10 Configuring Whether a Missing Device Causes the System to Become "NOT READY"	51
		4.8.11 Configuring the Time Period by which a Device is considered Missing.....	52

4.9 Arming/Disarming Options And Exit/Entry Delay	53	7. MAINTENANCE	75
4.9.1 Configuring Exit Modes	53	7.1 Handling System Troubles	75
4.9.2 Configuring Entry Delays Duration	53	7.2 Dismounting the Control Panel	76
4.9.3 Configuring Exit Delay Duration	54	7.3 Replacing the Backup Battery	76
4.9.4 Enabling Quick Arm	54	7.4 Fuse Replacement	76
4.9.5 Configuring Bypassing Zones	55	7.5 Replacing/Relocating Detectors.....	77
4.9.6 Configuring Panic Alarm Activation	56	7.6 Restoring Factory Defaults	77
4.9.7 Enabling Latchkey Arming	56	7.7 Viewing the Serial Number	77
4.10 User Interface Customization.....	57	8 READING THE EVENT LOG.....	78
4.10.1 Enabling Trouble Beeps.....	57	8.1 Reading the Event Log	78
4.10.2 Enabling Piezo Beeps	57	8.2 Erasing and Exiting the Event Log	78
4.10.3 Enabling the Back Light	58	APPENDIX A. Detector Deployment & Transmitter	Assignments
4.10.4 Configuring the Disarm Option.....	58	A1. Detector Deployment Plan	79
4.10.5 Configuring the Screen Saver Options	59	A2. Keyfob Transmitter List	80
4.10.6 Enabling the Memory Prompt.....	60	A3. Emergency Transmitter List.....	80
4.10.7 Enabling Keyfob Low Battery Acknowledgement	60	A4. Non-Alarm Transmitter List.....	80
4.11 DEFINE CUSTOM LOCATIONS.....	61	APPENDIX B. Event Codes.....	81
4.12 CONFIGURING OUTPUT PARAMETERS.	61	B1. Contact ID Event Codes.....	81
4.12.1 Preliminary Guidance	61	B2. SIA Event Codes.....	81
4.12.2 Define PGM	62	B3. 4/2 Event Codes.....	81
4.13 Configuring Remote Programming Access Permissions.....	66	B4. Understanding the Scancom Reporting Protocol Data Format	83
5 DIAGNOSTIC TEST	68	APPENDIX C. Glossary.....	84
5.1 Testing Devices	68	APPENDIX D. DEFAULT AND PROGRAMMED ZONE DEFINITIONS.....	86
5.1.1 Testing all Devices.....	68		
5.1.2 Testing One Device	69		
5.1.3 Displaying Signal Strength Indication of All Devices	70		
5.1.4 Displaying Signal Strength Indication of RF Devices	71		
5.1.5 GPRS Communication Test	71		
5.1.6 LAN Connection Test	72		
5.1.7 LAN Reset Option	73		
6 CALLING UPLOAD/DOWNLOAD SERVER	74		

MESSAGE TO THE INSTALLER

The PowerMaster-10 control panel is supplied with 3 instruction manuals:

- **Installer Guide** (this manual - for your exclusive use)
- **User's Guide** (for your use during installation only - Must be handed over to the master user after testing the system)
- **Accessories Guide** (includes a full description of devices that are supported by the PowerMaster-10 system)

Appendices A.1 and A.2 of the Installer Guide will help you prepare an installation plan. Please take time to fill out the forms - your job will become much easier and confusion will be prevented. Filling out the forms will also help you create a list of detectors and transmitters that must be obtained for the particular application. Compatible detectors and transmitters are listed in the Accessories Guide.

Remember - it is advisable to power up the control panel temporarily after unpacking and program it on the work bench, in accordance with the installation plan.

Although setting the correct time and date is one of the user tasks, we recommend that you set the time and date in the course of programming. Access to the "User Settings" for the installer is possible through the installer's menu or through the user menu (see User's Guide section 2).

After programming, proceed to install the system as detailed in the Installation Instructions, from paragraph **Error! Reference source not found.**

The installer should verify line seizure. Be aware of other phone line services such as DSL. If DSL service is present on the phone line, you must install a filter. It is suggested to use the DSL alarm filter model Z-A431PJ31X manufactured by Excelsus Technologies, or equivalent. This filter simply plugs into the RJ-31X jack and allows alarm reporting without breaking the internet connection.

Compliance Statement

Hereby, Visonic Group declares that the PowerG series of central units and accessories are designed to comply with:

- **U.S. Standards:** USA: (FCC) CFR 47 part 15 and part 68
- **Canada Standards:** RSS 210
- **European CE Standards**

The PowerMaster-10 is compatible with the RTTE requirements - Directive 1999/5/EC of the European Parliament and of the Council of 9 March 1999.

According to the European standard EN50131-1, the PowerMaster-10 security grading is 2 – "low to medium risk" and environmental classification is II – "indoor general" and the power supply type is A. EN 50131-6

- **GSM standards:**

Europe: Complies with CE standards 3GPP TS 51.010-1, EN 301 511, EN301489-7

USA: CFR 47 Part 22 (GSM850) and Part 24 (GSM 1900).

EMC standard: CFR 47 Part 15

1. INTRODUCTION

The PowerMaster-10[®] is a user and installer-friendly, 29-zone fully-supervised wireless control system using Visonic's new revolutionary PowerG™ two-way Time Division Multiple Access (TDMA) Frequency Hopping Spread Spectrum (FHSS) technology.

The system is designed to function in an appealing way to the user and also offers features that make installers' life easier than ever before:

PowerG Technology is easy to install and maintain

- **Quick and easy installation and on-site diagnostics:**

Choosing the ideal location to install a wireless device or testing it at a later stage can be very strenuous and frustrating. With PowerMaster-10 there is no need to run back and forth to the panel to read the link quality because PowerG devices have a quality link indicator built-into the device itself which enables choosing the ideal location quickly and easily without using the panel. See Chapter 3.

- **Quick and easy on-site and remote configuration of sensors and system peripherals:**

PowerMaster-10 devices (sensors, PIR cameras, sirens, keypads etc) can be configured from the control panel or from remote locations (installation or monitoring company's offices) with the option for using configurable defaults providing a collective device configuration.

This saves time since there is no need to travel to the installation site, to climb ladders and open devices. See – Chapter 4.

- **Cost-saving advanced remote diagnostics and walk testing:**

Many of the problems associated with wireless systems are due to invisible RF phenomena, such as interferences, changes in the premises and unstable link quality. Having a professional diagnostic tool in the RF network is critical for cost saving servicing of wireless alarm systems. The PowerMaster-10 performs continuous diagnostic tests on the RF environment and on interferences at the site and provides you (locally and remotely) with pertinent information that helps you to understand and resolve the problems.

In addition, PowerMaster-10 provides you with remote real time testing and walk testing of the system sensors and peripherals – saving you time and money in not needing to visit the site. See Chapter 5.

Main Benefits and Features:

- Two-way communication ensures there are no lost alarms
- Multiple channels (up to 50) and frequency hopping technology overcomes interferences to wireless communication
- Transmission range is by far greater than the industry standard (2000m, 6000ft), enabling repeater-free installations even in large premises
- Message collisions are eliminated by using the same technologies used in WiMAX, GSM and Bluetooth
- Devices dynamically start and stop using available repeaters according to need
- Smart mechanism enables adjacent systems to co-exist without disturbing one another
- Short keep-alive period provides reliable supervision of any vandalism attempts or device failure
- Communication is protected by the proven AES-128 encryption algorithm to protect against sophisticated intruders
- Two-way communication eliminates all unnecessary re-transmissions
- 5-8 years battery life for all peripherals*
- Minimum power consumption and "air pollution" due to:
 - Adaptive transmission power which is determined according to the level of RF interferences
 - Devices dynamically change wireless signal routing to utilize the most reliable communication pathway available
- All devices are configured from the panel – no hardware switches and no need to re-open the peripherals once closed
- 7-digit code on each device is used for easy local or remote enrollment
- Configuration templates enable to configure the devices collectively instead of individually
- Special button on each device prevents RF activity from interfering with enrollment procedures
- Wireless signal quality indication visible on all devices – enables to choose the ideal location for installation without using the panel during mounting of peripherals
- Powerful diagnostic tool indicates RF link quality to show abrupt problems and to verify installation in house setup.

- Remotely review and/or change configuration and status of all peripherals
- Initiate remote walk test with assistance by anyone in the house
- Remote diagnostics of wireless signal quality for all peripherals - measure all wireless connections and reports back

System Architecture:

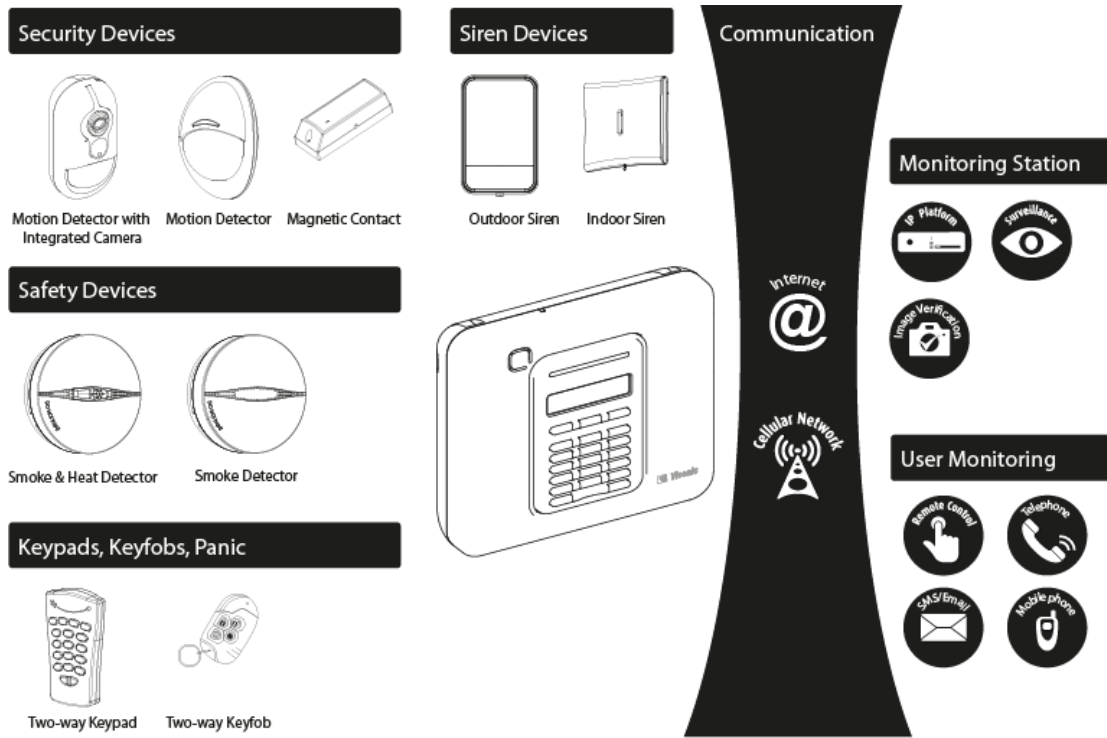

2. SPECIFICATIONS

Functional

Zones Number

28 wireless zones, 1 hardwired input.

Hardwired Zone Requirements

2.2 kΩ E.O.L. resistance (max. resistance of wires 220 Ω).

Installer and User Codes

- 1 master installer (9999 by default)*
 - 1 installer (8888 by default)*
 - 1 master user, no. 1 (1111 by default)
 - Users nos. 2 - 8
- * Codes must not be identical

Control Facilities

- Integral keypad, wireless keyfobs and keypads
- SMS commands via optional GSM/GPRS module.
- Remote control by telephone.

Note: For SIA CP-01 compliance, when using KF-234 PG2 an external siren must also be used.

Display

Single line, backlit 16-large character LCD.

Arming Modes

AWAY, HOME, AWAY-INSTANT, HOME-INSTANT, LATCHKEY, FORCED, BYPASS.

Alarm Types

Silent alarm, personal emergency alarm, burglary alarm and fire alarm.

Siren Signals	<u>Continuous</u> (intrusion / 24 hours / panic); <u>triple pulse - pause - triple pulse...</u> (fire).
Siren (bell) Timeout	Programmable (4 min. by default)
Internal Sounder Output	At least 85 dBA at 10 ft (3 m)
Supervision	Programmable time frame for inactivity alert
Special Functions	<ul style="list-style-type: none"> - Chime zones - Diagnostic test and event log. - Local and Remote Programming over Telephone, GSM /GPRS connections. - Calling for help by using an emergency transmitter. - Tracking inactivity of elderly, physically handicapped and infirm people.
Data Retrieval	Alarm memory, trouble, event log
Real Time Clock (RTC)	The control panel keeps and displays time and date. This feature is also used for the log file by providing the date and time of each event

Wireless

RF Network	PowerG – 2-way synchronized Frequency Hopping (TDMA / FHSS)		
Frequency bands (Mhz)	433 – 434	868 - 869	912 - 918
Hopping frequencies	8	4	50
Encryption	AES-128		

Electrical

External AC/AC adapter	<p>Europe: 230VAC 50Hz input, 9VAC 700mA output.</p> <p>USA: 120VAC 60Hz input, 9VAC 1000mA output.</p>
Internal AC/DC	<p>Switching power supply:</p> <p>Input: 100-240V AC, 0.12 A Max.</p> <p>Output: 7.5V DC, 1.2A Max.</p>
Current Drain	Approx. 70 mA standby, 1600 mA peak at full load.
Backup Battery Pack	<p>4.8V 1300 mAh, rechargeable NiMH battery pack, p/n GP130AAM4YMX, manufactured by GP or equivalent</p> <p>Note: For compliance with UL standards the battery backup period shall exceed 24 hours and 12 hours for compliance with CE standards.</p>
Time to Charge	80 % (~ 13 Hrs)
Optional Backup Battery Pack	4.8V 2200 mAh, rechargeable NiMH battery pack, p/n GP230AAHC4YMX, manufactured by GP
Low Voltage Alarm	~ 4.8V

Communication

Communication	PSTN; GSM; GPRS; IP (for future use)
Built-in Modem	300 baud, Bell 103 protocol
Data Transfer to Local Computer	Via RS232 serial port
Report Destinations	2 Monitoring Stations, 4 private telephones
Reporting Format Options	SIA, Pulse 4/2 1900/1400 Hz, Pulse 4/2 1800/2300 Hz, Contact ID, Scancom, SIA IP, Visonic PowerNet.

Pulse Rate	10, 20, 33 and 40 pps - programmable
Message to Private Phones	Tone
Ring Detection	The unit does not support ring detection without DC voltage present on the telephone lines.

Physical Properties

Operating Temp. Range	14°F to 120°F (-10°C to 49°C)
Storage Temp. Range	-4°F to 140°F (-20°C to 60°C)
Humidity	85% relative humidity, @ 30°C (86°F)
Size	196 x 180 x 55 mm (7-5/8 x 7 x 2 in.)
Weight	658g (23 Oz) (with battery)
Color	White

Peripherals and Accessory Devices

Modules	GSM/GPRS, IP (future use)
Additional wireless devices	30 detectors, 8 keyfobs, 2 keypads, 2 sirens, 4 repeaters
Wireless Devices and peripherals (*):	<p>Magnetic Contact: MC-302 PG2</p> <p>Motion Detectors: Next PG2; Next K9 PG2</p> <p>PIR Camera Detectors: Next CAM PG2; Next-K9 CAM PG2</p> <p>Smoke Detector: SMD-426 PG2/ SMD-427 PG2</p> <p>Keyfob: KF-234 PG2</p> <p>Keypad: KP-140 PG2</p> <p>Outdoor Siren: SR-730 PG2</p> <p>Repeater: RP-610 PG2</p>

(* *Visonic is currently developing many more devices and peripherals that will be available during 2011.*)

3. INSTALLATION

3.1 Choosing the Mounting Location

To ensure the best possible mounting location of the PowerMaster-10 control panel, the following points should be observed:

- Mount the system approximately in the center of the installation site between all the transmitters
- In close proximity to an AC source and a telephone line connection (if PSTN is used)
- Far from sources of interference, such as:
 - Electrical noise and strong electromagnetic sources, such as computers, television, power conductors, cordless phones, light dimmers, etc.
 - Large metal objects (such as metal doors and metal closets)
- **Note:** A distance of at least 1 meter (3 ft) is recommended.
- Make sure that the signal reception level for each transmitter's signal, shown during the Diagnostics test of the PowerMaster-10, is "Strong" or "Good".
- The alarm can be heard during HOME mode.
- Wireless magnetic contacts should be installed in a vertical position and as high up the door or window as possible.
- Wireless detectors should be installed at the height specified in their Installation Instructions
- Repeaters should be located high on the wall in mid-distance between the transmitters and the control panel.

WARNING! To comply with FCC RF exposure compliance requirements, the control panel should be located at a distance of at least 20 cm from all persons during normal operation. The antennas used for this product must not be co-located or operated in conjunction with any other antenna or transmitter.

3.2 Mounting the Unit

Required tool: Philips screwdriver #2.

PowerMaster-10 mounting process is shown in Figure 3.1 - 3.2.

Opening the Control Panel and Bracket Mounting

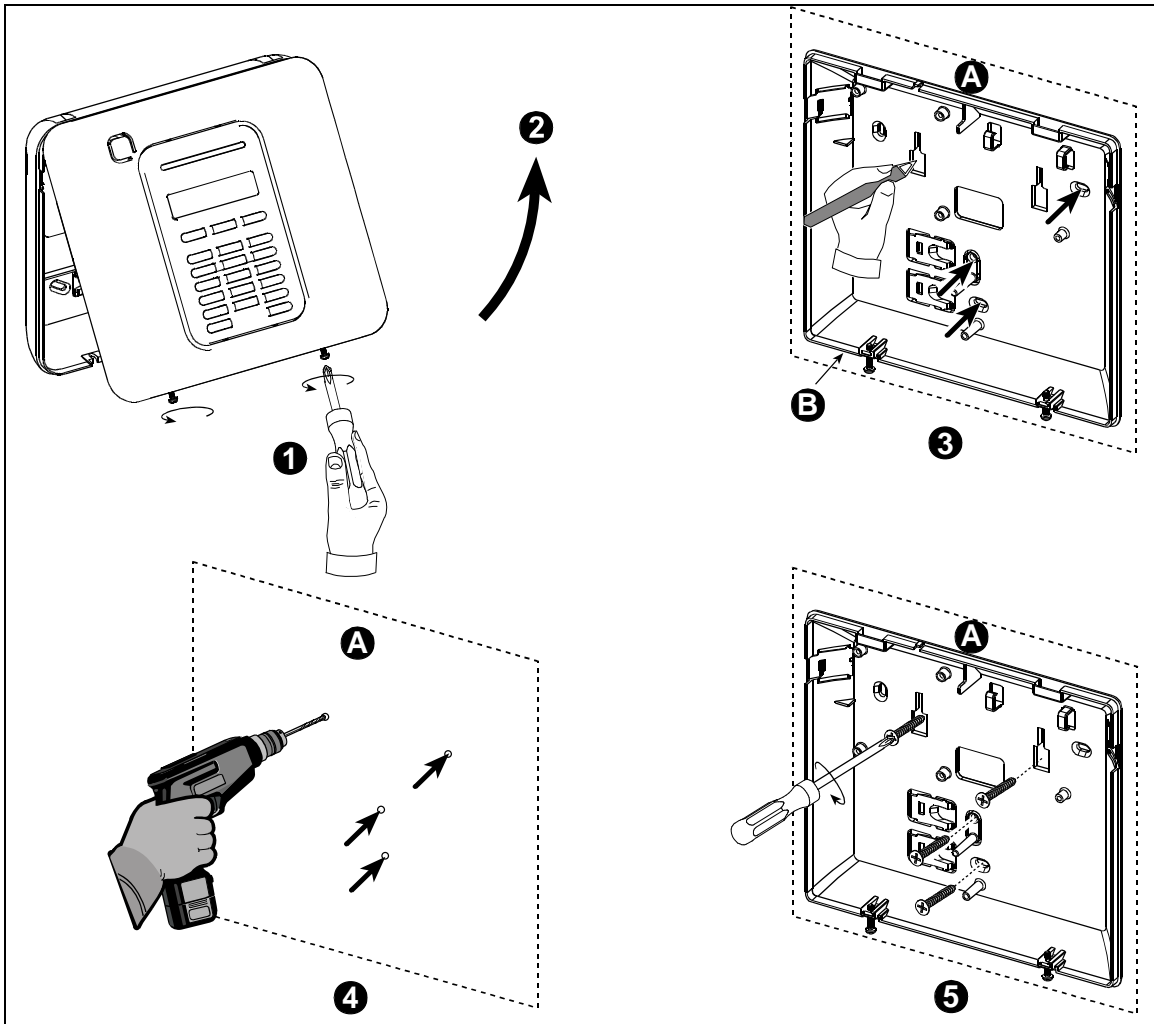

A. Mounting surface

B. Back unit

To Mount the Unit:

1. Release the screws
2. Remove the front cover
3. Mark 4 drilling points on the mounting surface
4. Drill 4 holes and insert wall anchors
5. Fasten the back unit with 4 screws

Figure 3.1 – Back Unit Mounting

WARNING! When plugging SIREN & ZONE terminals back into place, be sure to align them carefully with the pins on the PCB. Misaligned or reverse insertion of terminals may damage internal PowerMaster-10 circuits!

Closing the Control Panel

Control panel final closure is shown below.

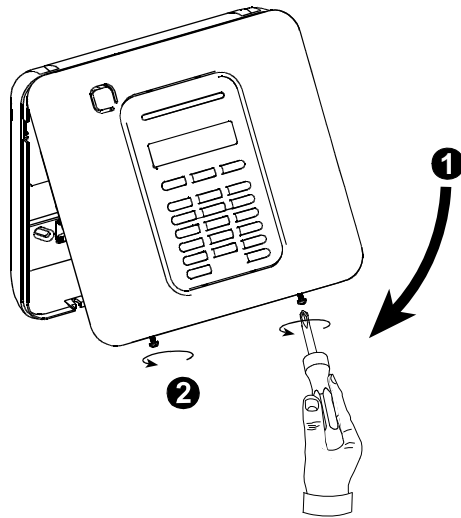

To Close the Control Panel:

1. Close the front cover
2. Fasten the screws

Figure 3.2 - Final Closure

3.3 Supplying Power to the Unit

Connect power to the PowerMaster-10 temporarily (see Figure 3.4). Alternatively, you may power up from the backup battery, as shown in Figure 3.3.

Disregard any "trouble" indications pertaining to lack of battery or lack of telephone line connection.

For Europe Safety Compliance:

- a. The model shall be installed according to the local electrical code.
 - b. The circuit breaker shall be readily accessible.
 - c. The rating of the external circuit breaker shall be 16A or less.
 - d. The cables for the AC mains connection shall have an overall diameter of 13mm and 16mm conduit.
- Please refer to Figure 3.4 "Power Cable Connection".

Inserting Backup Battery

Connect battery pack as shown in the next drawing.

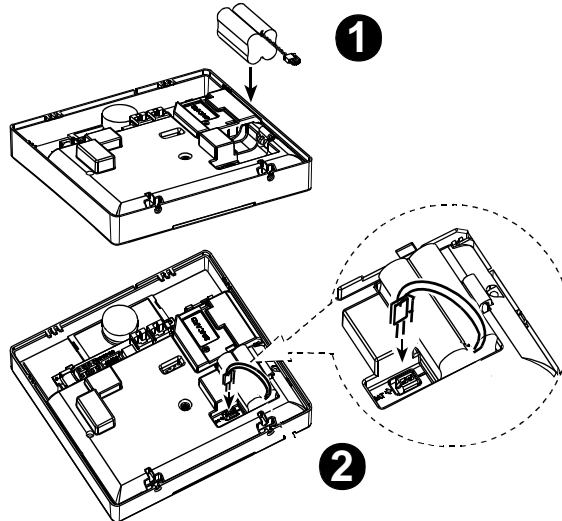

1. Battery insertion
2. Battery connection

Figure 3.3 – Connecting Power to the Control Panel

Connecting Power to Panel

Connect the power cable and close the control panel as shown below. Electrical socket-outlet shall be installed near the equipment and shall be easily accessible.

WARNING! DO NOT USE AN OUTLET CONTROLLED BY A WALL SWITCH.

Note: This equipment should be installed in accordance with Chapter 2 of the National Fire Alarm Code, ANSI/NFPA 72, (National Fire Protection Association).

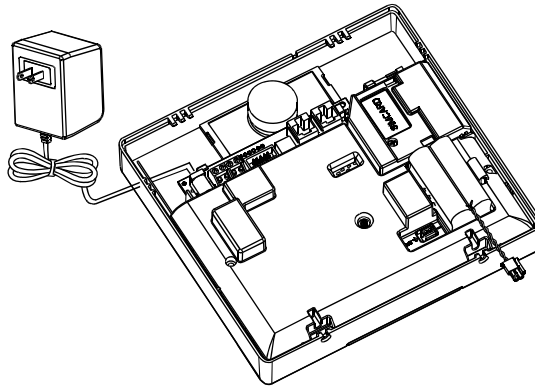

Connect the power adapter to the power connector.

Figure 3.4 - Power Cable Connection

3.4 Connecting to the Telephone Line

PHONE WIRING

Connect the telephone cable to the SET connector and connect the telephone line cable to the LINE connector (through the desired wiring cable entry). **Note:** The telephone cable should be no longer than 3 meters.

The diagram shows the control panel on the left. A dashed circle highlights a close-up of the terminal block with two connectors labeled 'A' and 'B'. A telephone cable is connected to connector 'A'. To the right, a telephone line wall jack labeled 'C' is shown with a telephone line cable plugged into it. A telephone is also connected to the wall jack. A line connects the wall jack to the 'LINE' connector (B) on the terminal block.

A. SET
 B. LINE
 C. Tel line wall jack

PHONE WIRING IN NORTH AMERICA

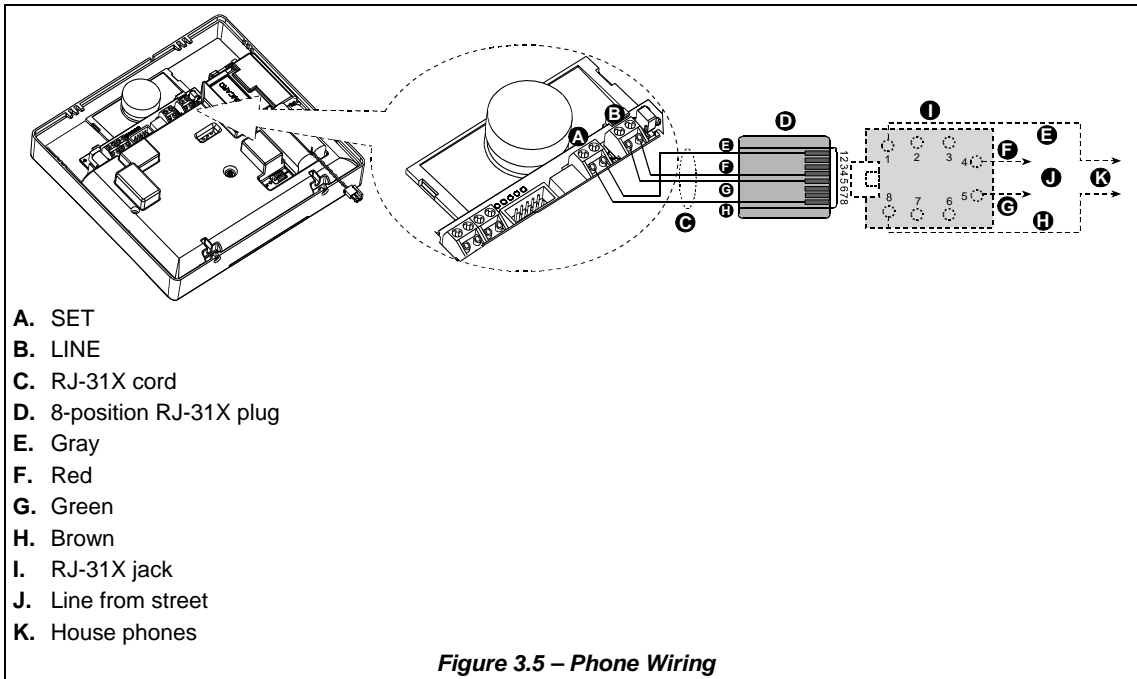

This equipment is designed to be connected to the telephone network using RJ11 connector which complies with Part 68 rules and requirements adopted by ACTA and properly installed RJ31X connector. See drawing below for details.

In the case that RJ31X is not available (consult your telephone company or a qualified installer), the telephone line should be connected to the PowerMaster-10 unit first and then all other home equipment should be connected to PowerMaster-10 "Phone" outlet.

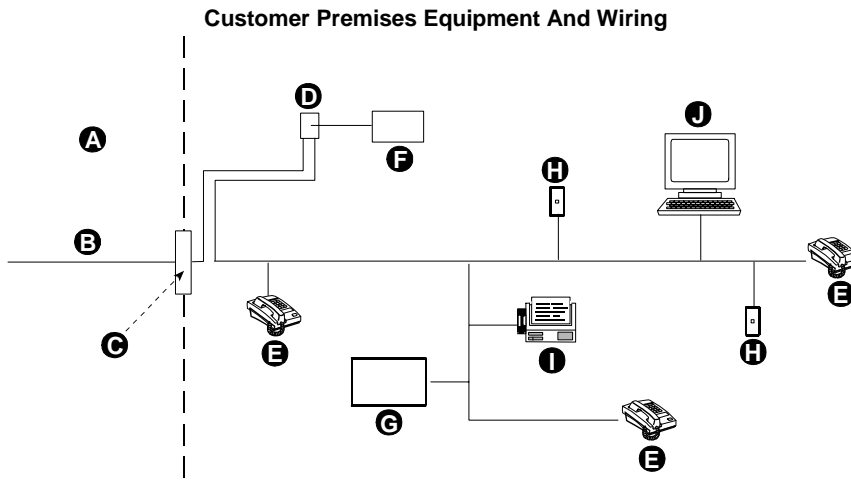

- A.** Network Service Provider's Facilities
- B.** Telephone Line
- C.** Network Demarcation Point
- D.** RJ-31X Jack
- E.** Telephone
- F.** Alarm Dialing Equipment
- G.** Answering System
- H.** Unused RJ-11 Jack
- I.** Fax Machine
- J.** Computer

Note: The REN is used to determine the number of devices that may be connected to a telephone line. Excessive RENs on a telephone line may result in the devices not ringing in response to an incoming call. In most but not all areas, the sum of RENs should not exceed five (5.0). To be certain of the number of devices that may be connected to a line, as determined by the total RENs, contact the local telephone company.

Connection to telephone company provided coin service is prohibited. Connection to party lines service is subject to state tariffs.

The installer should verify line seizure. Be aware of other phone line services such as DSL. If DSL service is present on the phone line, you must install a filter. It is suggested to use the DSL alarm filter model Z-A431PJ31X manufactured by Excelsus Technologies, or equivalent. This filter simply plugs into the RJ-31X jack and allows alarm reporting without breaking the internet connection.

3.5 System Planning & Programming

It pays to plan ahead - use the tables in appendices A and B at the end of this guide to register the intended location of each detector, the holder and assignment of each transmitter.

Gather up all transmitters and detectors used in the system and mark each one in accordance with your deployment plan.

Program the system now, before mounting, as instructed in the programming section.

3.6 Extension Modules GSM Installation

The internal GSM 350 module enables the PowerMaster-10 system to operate over a GSM/GPRS cellular network (for further details, see the GSM 350 PG2 Installation Instructions).

The GSM modem auto detection feature enables automatic enrollment of the GSM modem into the PowerMaster-10 control panel memory. GSM modem auto detection is activated in one of two ways: after tamper restore and after reset (power-up or after exiting the installer menu). This causes the PowerMaster-10 to automatically scan GSM COM ports for the presence of the GSM modem.

In the event that the GSM modem auto detection fails and the modem was previously enrolled in the PowerMaster-10.

G2 control panel, the message "Cel Rmvd Cnfrm" will be displayed. This message will disappear from the display only after the user presses the **OK** button. The modem is then considered as not enrolled and no GSM trouble message will be displayed.

Note: A message is displayed only when the PowerMaster-10 alarm system is disarmed.

PowerLink Broadband Module Installation

The PowerLink broadband module enables viewing the PowerMaster-10 system over the internet (for further details, see the PLINK PRO Installation Instructions).

The PowerLink Broadband Module modem auto detection feature enables automatic enrollment of the PowerLink Broadband Module modem into the PowerMaster-10 control panel memory. The PowerLink Broadband Module modem auto detection is activated in one of two ways: after tamper restore and after reset (power-up or after exiting the installer menu). This causes the PowerMaster-10 to automatically scan the PowerLink Broadband Module COM ports for the presence of the PowerLink Broadband Module modem.

In the event that the PowerLink Broadband Module modem auto detection fails and the modem was previously enrolled in the PowerMaster-10 control panel, the message "PLNK Remvd Cnfrm" will be displayed. This message will disappear from the display only after the user presses the **OK** button. The modem is then considered as not enrolled and no PowerLink Broadband Module trouble message will be displayed.

Notes:

A message is displayed only when the PowerMaster-10 alarm system is disarmed.

In the event of a power failure the PowerLink Broadband Module will not operate. Power (AC or battery) must be disconnected from the circuit before connecting / disconnecting the PowerLink Broadband Module.

3.7 Annual System Check

Note: *This system must be checked by a qualified technician at least once every three (3) years (preferably every year).*

The annual system check is designed to ensure proper operation of the alarm system by performing the following checks:

- Periodic test
- Arm/disarm function
- No trouble messages are displayed on control panel
- The clock displays the correct time
- Reporting: generating an event to be transmitted to the central station and to the user.

4. PROGRAMMING















4.1 General Guidance



We recommend programming the PowerMaster-10 on the work bench before actual installation. Operating power may be obtained from the backup battery or from the AC power supply.

4.2 Entering the Installer Menu

The following procedure describes how to enter the Installer Menu.













To Enter the Installer Menu





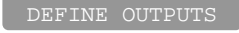























1.  Make sure the system is disarmed and then press the  button repeatedly until the PowerMaster-10 display reads "INSTALLER MODE".
2. 



 Enter your Installer Code.
3. 
 Enter your Installer Code.
4.  or  Press the  or  button repeatedly until the display reads the desired setting option, for example, "ZONES/DEVICES".

You can program any other menu or press the  or  buttons to take you to "<OK> TO EXIT".

Installer Mode Options Menu

Click the  button until the display reads the desired setting option and then press the  button.

- | | |
|--|---|
| 
 | Use to program the Installer Code and the Master Installer Code . See section 4.4.1 |
| 
 | Use to Add, Delete, Configure, Replace and Configure devices and also to define your personal set of Defaults for device configuration. See section 4.5. |
| 
 | Use to define control panel parameters. See sections 4.6, 4.8, 4.9 and 4.10. |
| 
 | Use to define control panel communication parameters. See section 4.7. |
| 
 | Use to define the PGM output. See section 4.12. |
| 
 | Use to define custom zone names. See section 4.11. |
|  | Use to test and identify devices and wireless communication link quality. See Chapter 5. |

 	Chapter 5.
 	Use to enter the USER SETTINGS menu to perform user settings. See section 4.2.
 	
 	
 	Use to restore the control panel to factory defaults. See section 7.6.
 	
 	
 	Use to read the serial number of the control panel. See section 7.7.
 	
 	Use to initiate the upload/download process. See Chapter 6.
 	
 	
 	Use to exit from the “INSTALLER MODE” menu back to Main Menu. See section 4.3.
 	Returns to first option

Programming User Settings

This mode provides you with a gateway to the user functions through the regular user programming menu.



To Enter the User Settings Menu

1. Repeat steps 1 to 4 of section 4.2 "Entering the Installer Menu".

  USER SETTINGS



- 2.

  I OK





Refer to the PowerMaster-10 User Guide for detailed procedure. Clicking the  or  buttons at any stage in the procedure will take you to “<OK> TO EXIT”.

Caution! If after having programmed the user codes the system does not recognize your installer code, this indicates you must have programmed a user code that is identical with your installer code. If so, access the user menu and change the code that is identical with your installer code. This will re-validate your installer code.





4.3 Navigation

This mode allows you to customize the control panel and adapt its characteristics and behavior to the requirements of the particular user. To review the options within the control panel menus, repeatedly press the  or  button, until the desired option is displayed, then press the  button.

You will mainly use 5 control pushbuttons during the entire programming process:

	- to move one step forward in a menu.
	- to move one step backward in a menu.
	- to enter the relevant menu or confirm data.
	- to move one level up in a menu.
	- to return to the "OK TO EXIT" state.

The sounds you will hear while programming are:

	- Single beep, heard whenever a key is pressed.
	- Double beep, indicates automatic return to the normal operating mode (by timeout).
	- Happy Melody (- - - —), indicates successful completion of an operation.
	- Sad Melody (—), indicates a wrong move or rejection.

If you enter an invalid installer code 5 times, the keypad will be automatically disabled for 90 seconds and the message WRONG PASSWORD will be displayed.

4.4 Permissions and User Codes

The PowerMaster-10 system includes four code levels, as follows:

- **Installer Code:** By using the installer code, the menu enables changing the installer code.
- **Master Installer Code:** By using the master installer code, the menu enables changing both master installer code and installer code.
- **User Code:** See PowerMaster-10 User Guide
- **Master User Code:** See PowerMaster-10 User Guide

Not every system includes a MASTER INSTALLER code. In a system with an INSTALLER code only, the installer can use all the functions in the system.

The following actions can be done only by using the master installer code:

- Changing master installer code.
- Resetting the PowerMaster-10 parameters to the default parameters,
- Defining specific communication parameters.

You are expected to use this code only once for gaining initial access, and replace it with a secret code known only to yourself.

4.4.1 Setting a New Installer Code

To set an installer code, perform the actions that are presented below. When you are instructed to enter code, enter a 4-digit code.

A. To Set a New Installer Code

1. Repeat steps 1 to 4 of section 4.2 "Entering the Installer Menu".

2. 





Note: The menu displayed within the dashed box appears only if the control panel includes the Master Installer Code.

3. 

4. 



Enter the new 4-digit Installer Code (8888 or 9999) at the position of the blinking cursor and then press **OK**.*

* The default Installer Code is 9999.
If your system uses MASTER CODE, you should proceed to setting the MASTER INSTALLER code in section 4.4.2 by pressing the **▶▶** button, or press the **🔒** button to take you to "<OK> TO EXIT".

Note: Installer Code should never be programmed as "0000". Doing so will lock the user out of the installer menu!

4.4.2 Setting the Master Installer Code

For PowerMaster-10 with MASTER INSTALLER code, set a new INSTALLER code as described in section 4.3.1 "Setting a New Installer Code" and set the MASTER INSTALLER code as described in this section.

Note: For Control Panel that has installer code & master installer code, the following functions are available only if the MASTER INSTALLER code is entered:

- PSTN/GSM RCVR1
- RCVR 1 ACCOUNT#
- PSTN/GSM RCVR2
- RCVR 2 ACCOUNT#
- PSTN RPRT FORMAT
- 4/2 PLS RATE
- REPORT EVENTS
- RPRT CNFRM ALRM
- SEND 2WV CODE
- RINGBACK TIME
- PSTN RPRT RETRY
- GSM RPRT RETRY
- MAST. DL CODE

By using the master installer code, the menu enables changing both master installer code and installer code. By using the installer code, the menu enables changing the installer code only.

B. To Set a New Master Installer Code

1. Repeat steps 1 to 4 of section 4.2 "Entering the Installer Menu".

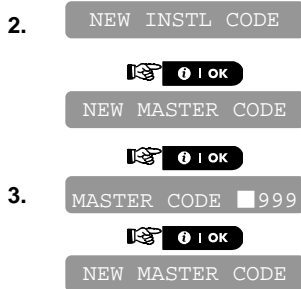

Enter the new 4-digit Installer Code (8888 or 9999) at the position of the blinking cursor and then press **OK**.*

* **Master Installer** Code should never be programmed as ' 000'. Doing so will lock the user out of the installer menu!
You can now press the **▶▶** button to set the INSTALLER code or press the **🔒** button to take you to "<OK> TO EXIT".

4.4.3 Setting User Codes

For detailed instructions on setting user codes, refer to the PowerMaster-10 user guide "Menus and Functions".

4.4.4 Enabling User Permit for Installer Access

User Permission enables you to determine whether access to the INSTALLER MODE requires user permission. Access to the installer menu, in PowerMaster-10 that has "User Permission" enabled (for example, in UK) is via the last menu in the user menu. This option can be changed, if necessary. Here you determine whether the access to the INSTALLER MODE requires user permission. If you select ENABLE, the installer mode will be accessible only through the user menu after entering the user code.

Options: **Enable** (default in UK), **Disable** (default).

Note: To comply with EN requirements, "Enable" must be selected.

To Enable User Permit for Installer Access

1. Repeat steps 1 to 4 of section 4.2 "Entering the Installer Menu".

2. DEFINE PANEL

3. 

01:ENTRY DELAY 1

4.  or 

36:USER PERMIT

5. 

Disable

Select between "Disable" (default) and "Enable".



36:USER PERMIT

You can now press the  or  button to program any other menu in "DEFINE PANEL" or press the  button to take you to "<< >> TO EXIT".

4.4.5 Configuring Permissions for System Reset after Alarm Event

(Not applicable in the USA)

Here you determine whether the system can be rearmed (after an event) by the user or only by the installer.

Options: **user reset** (default), **engineer reset**, or **anti code reset**.

If Engineer Reset is selected, the system can be rearmed only by the installer; by entering and exiting the installer menu, by entering and exiting the event log (see section 8), or by remote telephone. To perform Engineer Reset via the telephone, establish communication with the PowerMaster-10 (see user guide, Chapter 5) and continue as follows:

a. + "*", "installer code", "#"

b. Wait for 2 beeps

c. + "*", "1", "#"

d. + "*", "99", "#"

Visonic uses Technistore anti code reset. Installers should check with their Monitoring Station for a code version (seed code) which needs to be entered.

To Configure Permissions for System Reset after an Alarm Event

1. Repeat steps 1 to 4 of section 4.2 "Entering the Installer Menu".

2. DEFINE PANEL

3.  

01:ENTRY DELAY 1

4.  or 

25:RESET OPTION

5.  

user reset

Select between "user reset" (default), "engineer reset" and "anti code reset".

25:RESET OPTION

You can now press the  or  button to program any other menu in "DEFINE PANEL" or press the  button to take you to "<OK> TO EXIT".

4.4.6 Configuring a Duress Code

A duress alarm (ambush) message can be sent to the Monitoring Station if the user is forced to disarm the system under violence or menace. To initiate a duress message, the user must disarm the system with the duress code (2580 by default). Here you can change the code digits or enter "0000" to disable the duress feature. **The system does not allow the user to program the duress code saved in this memory location as an existing user code.**

Note: Duress Code is not applicable in the UK.

To Configure a Duress Code

1. Repeat steps 1 to 4 of section 4.2 "Entering the Installer Menu".

2. DEFINE PANEL

3.  

01:ENTRY DELAY 1

4.  or 

23:DURESS

5.  

DURESS CODE 2580

Change the code or enter 0000 to disable the duress function.

23:DURESS

You can now press the  or  button to program any other menu in "DEFINE PANEL" or press the  button to take you to "<OK> TO EXIT".

4.5 Zones / Devices

4.5.1 General Guidance

The ZONES / DEVICES mode enables the following functions:

- Defining default parameters common for each devices family.
- Adding new devices (enrolling) and defining their zones name, zone type and chime zone.
- Deleting devices.
- Modifying devices parameters.
- Reviewing devices parameters.

Enrolling can be performed for Keyfobs (multi-button), wireless detectors, wireless sirens and repeaters.

The control panel enables entering a device identification (ID) instead of enrolling an actual device. This enables pre-enrolling off site.

Upon boot up, the control panel checks if there are pre-enrolled devices that have not yet been registered (ID of the devices are entered but the devices have not communicated with the control panel). In this case, the control panel will display "SYNC WITH DEV" on the LCD and the trouble LED will be on until all the devices have registered or the pre-enrolled devices that have not registered will be deleted from the enrollment menu.

Refer to sections 4.4.3 and 4.4.4 for detailed instructions on Enrolling/Deleting a device.

Notes

- Keyfob enrolling can be performed also by the user (via USER SETTINGS menu).
- Wired magnetic contact or any other contact can be enrolled in zones 29 & 30.
- Wireless detectors can be enrolled in zones 01-28.

Before beginning, gather all the devices that you intend to enroll and make sure they all have batteries installed.

Your control panel must recognize the unique identification code (ID) of each such detector in order to supervise them, receive their signals and respond accordingly.









- Before enrolling, the lens at the front of PIR and dual-technology sensors should be masked to prevent inadvertent transmission.
- Make sure that magnetic contact transmitters are together with their magnets, to prevent them from sending out alarm transmissions.

4.5.2 Adding a Wireless Device

This section describes how to add a new device to the PowerMaster-10 control panel.

Note: It is much easier to enroll the device while holding the device in your hand, close to the control panel.

A. To Add a Device

1. Repeat steps 1 to 4 of section 4.2 "Entering the Installer Menu".
2. 
3. 

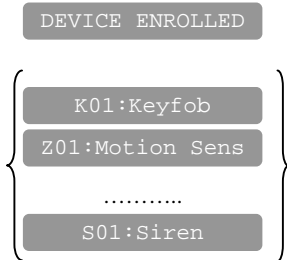
4.  You are now instructed to enroll the device.
5. 
 Enter the 7-digit number printed on the back side of the device and press
 or

 Perform the enrollment sequence for the specific device:
For most devices: Remove the device bracket or cover and press the device's Enroll button continuously until the red & green LEDs turn ON and then release. The PowerMaster-10 will indicate the result on its LCD display.
For Keyfobs: Press the '*' button until the red LED blinks rapidly and then release (the LED will continue blinking) then press the same button again. The LED lights green and the PowerMaster-10 will indicate the result on its LCD display.



The PowerMaster-10 display reads "DEVICE ENROLLED" (or "ID accepted" if the device was enrolled manually by entering the ID number) and the PowerMaster-10 display will then change to K01:Keyfob / Z01:Motion Sens / S01:Siren depending on the type of enrolled device".

However, if the device was previously enrolled in the system, the PowerMaster-10 display reads "ALREADY ENROLLED".

Repeat the above procedure for each device to be enrolled in the PowerMaster-10 system.

Continue to section 4.4.2.1 Assigning a Location, Zone type and Chime Option.

When exiting "ZONES / DEVICES" menu the PowerMaster-10 system displays the number of devices that need to be updated, as follows: DEV UPDATING NNN.

* If you enter the 7-digit number, you must physically install the device to complete the procedure. If the device is not installed the system will display the device as "NOT NET" (device is pre-enrolled – not networked).

You can now press the button to enroll the next device of the same type or press the button to move to the "LOCATION" menu (see section 4.4.2.1) or press the button to take you to "<OK> TO EXIT".

4.5.2.1 Assigning a Location, Zone type and Chime Option

B. To Assign a Location, Zone Type and Chime Option

The PowerMaster-10 system behavior is defined according to one of 11 zone types assigned to each of the system's 30 (wireless & wired) zones.





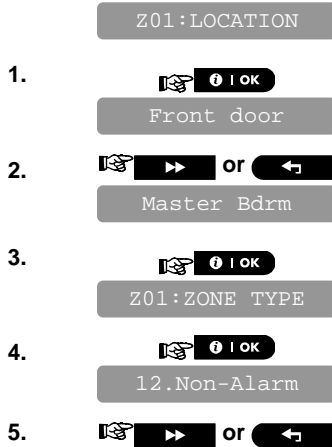









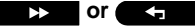

Note: This step is applicable to detectors only.

Continue below from the previous section.



Select a zone type, or, enter the zone type number, for example, pressing 03 selects "3. Home Delay".



To understand the behavior of each zone, see section 4.5.2.3 Zone Types.

6.  
Z01:SET CHIME
7.  
Chime off... 
8.   or 
9.  
melody-chime
Z01:DEV SETTINGS
10.  
NEXT device
11.  
MODIFY SAME Dev.
12.  
EXIT Enrollment

Press  to change chime settings or press the  button to skip.

Select between "Chime off" and "melody-chime".

Note: In "melody chime" mode when a chime zone is triggered, chime melody is heard.

* When the PowerMaster-10 will read "NEXT device" you can click the  button to enroll the next device. When the PowerMaster-10 will read "MODIFY SAME Dev." you can click the  button to modify the same device. When the PowerMaster-10 will read "EXIT Enrollment" you can click the  button to revert to "ADD NEW DEVICES".

4.5.2.2 Configuring Device Parameters

Refer to the PowerMaster-10 Accessories Guide for detailed instructions on how to modify specific device settings for each device

4.5.2.3 Zone Types

Upon enrollment of a new detector (marked "Zxx") you must select the proper zone type. The zone type determines how the system handles alarms and other signals sent from the device.

A list of factory defaults is printed in Appendix D. You may fill out the blank columns even before you start and proceed to program according to your own list.

Zone types are fully explained below:

Delay Zones:

A delay zone has exit and entry delays set by you in the course of programming the system. Warning beeps will sound throughout these delays, unless you choose to mute them.

- **Exit Delay** - The exit delay begins once the user arms the system. It allows him to leave via interior zones and a doorway before arming actually takes effect. When the exit delay starts, the buzzer beeps slowly and maintains a slow beeping rate until the last 10 seconds, during which it beeps rapidly. The PowerMaster-10 has two types of delay zones, for which different delay times may be set.
- **Entry Delay** - The entry delay begins once the user enters the protected area via a specific doorway (his entry is sensed by a delay zone detector). To avoid an alarm, he must reach the keypad via interior zones (which become "follower zones" during the entry delay) and disarm the system before the delay expires. When the entry delay starts, the buzzer beeps slowly until the last 10 seconds, during which it beeps rapidly.

Remember!

A delay zone is also a perimeter zone by definition.

Emergency Zones:

You can provide incapacitated, sick or elderly people with a miniature single-button transmitter to be carried on the neck like a pendant or to be worn on the wrist like a watch. In distress situations, they can press the button on their transmitter, causing the PowerMaster-10 to send an **emergency call** to the Monitoring Station or to private telephones designated by the installer.

To make this possible, define the required number of zones as emergency zones and enroll a portable transmitter to each one of these zones. When completed, ask the master user to distribute these transmitters to their potential users.

Interior Zone:

Interior zones are zones within the protected premises that have nothing to do with perimeter protection. Their most important feature is that they allow free movement within the protected area without initiating an alarm, provided that the system is armed in the "HOME" mode. People can therefore stay at home and move about freely, as long as they do not disturb a PERIMETER zone.

Once the system is armed in the AWAY mode (all zones are protected), interior zones will initiate an alarm if violated.

Interior Follower Zones:

"Interior Follower" zone is a zone that is located between entry/exit zone and the alarm system control panel. This zone is temporarily ignored by the alarm system during entry/exit delay periods, to enable you to walk (without causing an alarm) in front of a motion detector that is associated with the Interior Follower zone, after you enter through an entry zone on the way to the control panel, or when leaving the protected premises after system arming.

Home/Delay Zones:

A zone type which functions as a delay zone when the system is armed HOME and as a perimeter-follower zone when the system is armed AWAY.

Non-Alarm Zones:

A non-alarm zone does not directly participate in the alarm system. It can be used for chime or for optional KEY ON-OFF feature (when enabled).

You can define the desired number of non-alarm zones and enroll a portable transmitter or a wireless device (detector) to this type of zone.

Perimeter Zones:

Perimeter zones rely on detectors designed to protect doors, windows and walls. An immediate alarm is initiated when such a zone is violated by opening the door/window or by trying to break the wall.

Perimeter Follower Zones:

A non-entry/exit zone, typically a perimeter zone located on an entry/exit path, that is treated as an entry/exit zone during an entry/exit time.

24-Hour Zones:

24 hour zones are mainly used for PANIC buttons, perimeter detectors and anti-tamper protection. They therefore trigger an alarm in both armed and disarmed states.

- **24 Hour Zone - Silent.** - Upon detection, this zone initiates a silent alarm, meaning that the sirens do not function. Instead the PowerMaster-10 dials telephone numbers and reports the event to Monitoring Stations and/or to private telephones, as programmed.
- **24 Hour Zone - Audible.** - Upon detection, this zone initiates a siren alarm. The PowerMaster-10 also dials telephone numbers and reports the event to Monitoring Stations and/or to private telephones, as programmed.

4.5.2.4 Locations

You can select or assign a named location to a device (e.g. Garage, Front Door etc.). 31 locations can be selected, 26 fixed names and 5 custom names (defined by the installer).

Note: Custom Locations can be defined via the *DEFINE CUSTOM* menu, and these custom names will also appear on your location list in addition to the default names.

Note: To facilitate assigning a location name to a device, a shortcut procedure may be used by entering the location number which takes you directly to the location name.

Selectable Locations:

Attic
Back door
Basement
Bathroom
Bedroom

Child room
 Closet (UK: Conservatory)
 Den (UK: Playroom)
 Dining room
 Downstairs
 Emergency
 Fire
 Front door
 Garage
 Garage door
 Guest room
 Hall
 Kitchen
 Laundry room
 Living room
 Master bath
 Master bdrm
 Office (UK: Study)
 Upstairs
 Utility room
 Yard (UK: Garden)
 Custom 1
 Custom 2
 Custom 3
 Custom 4
 Custom 5

4.5.3 Adding Wired Zones

Required tools: Cutter and slotted screwdriver - 3 mm blade.
 PowerMaster-10 wiring is shown in Figure 4.1.

CABLES ROUTING GUIDE

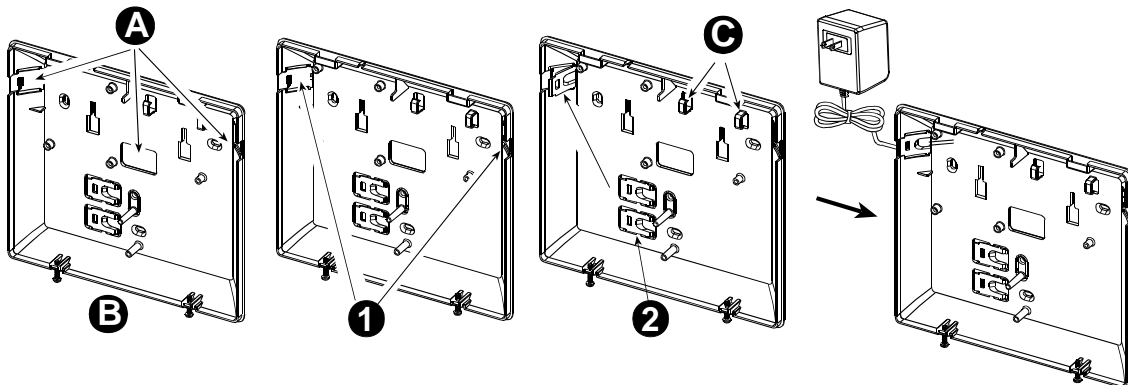

- A. Cables entry options
- B. Back unit
- C. Cable clips

To Route the Cable:

1. Remove the left or right side cables entry knockout(s) and enter the required cable(s)
2. Remove and use as cable clamp(s)

ZONE WIRING

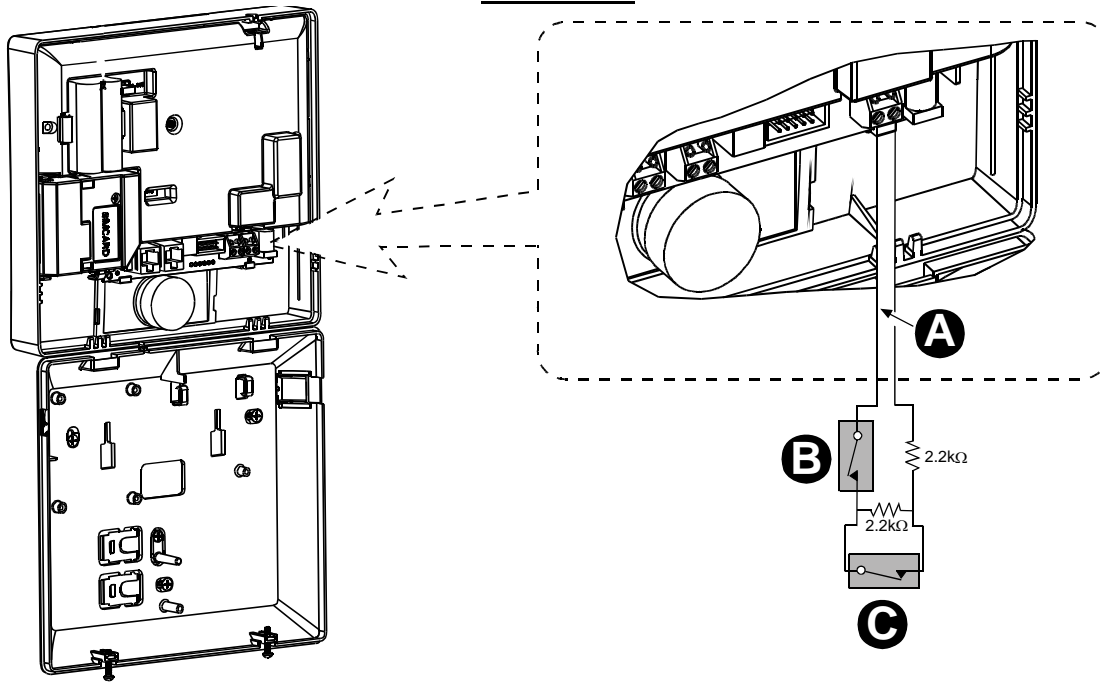













- A. ZONE
- B. TAMPER
- C. ALARM





Note: Do not use mains cable other than that supplied by the manufacturer (3 m long).



Figure 4.1 - Wiring

4.5.4 Deleting a Device

C. To Delete a Device

1. Repeat steps 1 to 3 in section 4.5.2 "Adding a Wireless Device".
 - ADD NEW DEVICES
2.  
 - DELETE DEVICES
3.  
 - CONTACT SENSORS
4. Select the type of device to be deleted. Select between "CONTACT SENSORS", "MOTION SENSORS", "SMOKE SENSORS", "WIRED SENSORS", "KEYFOBS", "SIRENS" and "REPEATERS" for example, "MOTION SENSORS".
 -   or 
 - MOTION SENSORS
5.  
 - Z01:Motion Sens
6.   or  Select the motion sensor to be deleted, for example, "Z03:Motion Sens".

- 7.  Z03:Motion Sens

- 8.  MOTION SENSORS



The device is deleted from the PowerMaster-10 system.
 When exiting "ZONES / DEVICES" menu the PowerMaster-10 system displays the number of devices that need to be updated, as follows: DEV UPDATING NNN.
 You can now press the  button to delete the device of the same type, or press the  button to delete a different device, or press the  button to take you to "<OK> TO EXIT".

4.5.5 Modifying a Device

D. To Modify a Device

Note: This procedure is applicable to detectors only.

- 1. Repeat steps 1 to 3 in section 4.5.2 "Adding a Wireless Device".

- 2.  ADD NEW DEVICES
MODIFY DEVICES

- 3.  CONTACT SENSORS

Select the desired sensor to be modified. Select between "CONTACT SENSORS", "MOTION SENSORS", "SMOKE SENSORS" and "WIRED SENSORS", for example, "MOTION SENSORS".

- 4.  Z01:Motions Sens

- 5.  Z01:LOCATION

- 6.  Front door

The PowerMaster-10 display will read "Front door".

- 7.  Master Bdrm

Select a location, or, enter the location number, for example, "Master Bdrm".









- 8.  Z01:ZONE TYPE

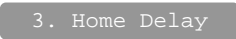

- 9.  12.Non-Alarm

- 10. Select a zone type, or, enter the zone type number, for example, pressing 03 selects "3. Home Delay".

To understand the behavior of each zone, see section 4.5.2.3 Zone Types.



- 

11.  
12.  
13.   or 
14.  

Press  to change chime settings or press the  button to skip.

Select between "CHIME OFF" and "melody-chime".

















Note: In "melody chime" mode when a chime zone is triggered, chime melody is heard

You can now press the  button to modify the next device of the same type, or press the  button to configure the parameters of the device (see the Accessories Guide for instructions), or press the  button to take you to "<OK> TO EXIT".

4.5.6 Replacing a Device

This feature is used for replacing a device that is enrolled in the system with another device of the same type while keeping the same parameters of the original device. This can save valuable time, since instead of having to delete the original device from the control panel, then to enroll the new device and then to set the device parameters again – all this can now be performed in one short procedure.

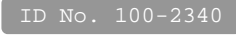
To Replace a Device

1. 
2.  
3.   or 
4.  
5.   or 
6.  
7.   or 

Repeat steps 1 to 4 of section 4.2 "Entering the Installer Menu".

Select the desired device type to be replaced. Select between "CONTACT SENSORS", "MOTION SENSORS", "SMOKE SENSORS", "KEYFOBS", "SIRENS" or "REPEATERS", for example, "CONTACT SENSORS".

The PowerMaster-10 display will read the name of the first enrolled device of the selected type to be replaced alternating with the ID number of the device.

At this stage you can select another device of the same type (in this example, contact sensor) to be replaced.

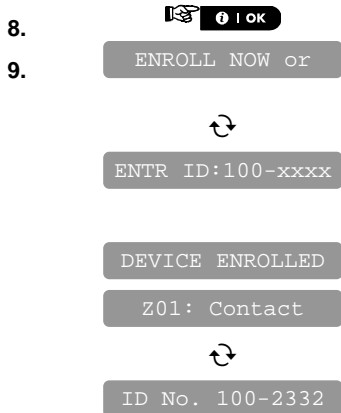

Enroll the new device, or, enter the last 4 digits of the ID number of the new device.*

The PowerMaster-10 display will read the result.**

* If the device was previously enrolled in the system, the PowerMaster-10 display reads "ALREADY ENROLLED" and then switches to the name of the device alternating with the ID number of the device. If the device ID number is invalid the PowerMaster-10 display reads "WRONG ID No".
 If the new device type is different from the existing device to be replaced, the PowerMaster-10 display reads "WRONG DEV.TYPE".
 ** If the device was enrolled manually, by entering the ID number, the PowerMaster-10 display reads "ID ACCEPTED".
 At the end of the procedure you can press the button and perform the same procedure for a different device of the same type, or you can press the button to select a different device type to be replaced, or you can press the button to take you to "<OK> TO EXIT".

4.5.7 Defining Defaults

Attention! When changing the default parameters of one device in Define Defaults, all new devices of the same device type that are enrolled in the PowerMaster-10 system will have the same defaults. Devices that were already enrolled in the PowerMaster-10 system before the procedure was performed will not be affected by the new default settings.

To Define Device Defaults

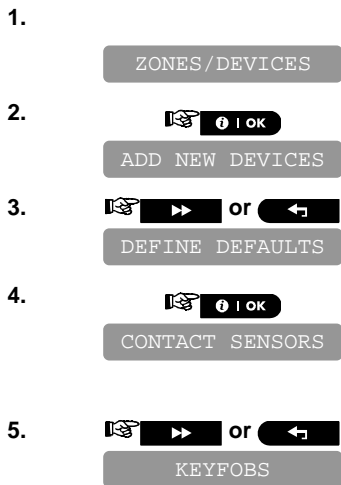

Repeat steps 1 to 4 of section 4.2 "Entering the Installer Menu".

Select the desired device whose defaults you wish to define. Select between "CONTACT SENSORS", "MOTION SENSORS", "SMOKE SENSORS", "KEYFOBS" and "SIRENS", for example, "KEYFOBS".

6.



For reviewing parameter configurations refer to the PowerMaster-10 Accessories Guide in section "MODIFY DEVICE SETTINGS" of the desired device.

At the end of the procedure you can press the button and perform the same procedure for a different device or you can press the button to take you to "<OK> TO EXIT".

4.6 Siren Configuration

4.6.1 Configuring the Length of Time the Bell is Allowed to Function

Here you select the length of time the bell (or siren) is allowed to function upon alarm. The bell time starts upon activation of the siren. Once the bell time expires, the siren is automatically shut down.

Available options are: **1, 3, 4** (default), **8, 10, 15** and **20** minutes.

Note: To comply with EN requirements, the Bell Time should be set to 15 min. max.

To Configure the Length of Time the Bell is Allowed to Function

1.



Repeat steps 1 to 4 of section 4.2 "Entering the Installer Menu".

2.



3.



4.

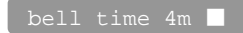

5.



Select between "bell time 1m", "bell time 3m", "bell time 4m", "bell time 8m", "bell time 10m", "bell time 15m" and "bell time 20m".

6.



You can now press the or button to program any other menu in "DEFINE PANEL" or press the button to take you to "<OK> TO EXIT".

4.6.2 Enabling the Internal Siren

Here you determine whether the internal siren will sound or remain silent upon alarm (according to the user preference). Options: **piezo siren on** (default), **piezo siren off**.

To Enable the Internal Siren

1.









Repeat steps 1 to 4 of section 4.2 "Entering the Installer Menu".

2.





3.



4.  
5.   or 
6.  

Select between "piezo siren ON" and "piezo siren OFF".













You can now press the  or  button to program any other menu in "DEFINE PANEL" or press the  button to take you to "<OK> TO EXIT".

4.6.3 Configuring the Period of Strobe Light Activation

Here you can define the period of strobe light activation when the siren is in alarm state.



Options: **5 minutes, 10 minutes, 20 minutes** (default), **40 minutes and 60 minutes**.

To Configure the Period of Strobe Light Activation

1. 
2.  
3.   or 
4.  
5.   or 
6.  

Repeat steps 1 to 4 of section 4.2 "Entering the Installer Menu".





Select between "5 minutes", "10 minutes", "20 minutes", "40 minutes" and "60 minutes".

You can now press the  or  button to program any other menu in "DEFINE PANEL" or press the  button to take you to "<OK> TO EXIT".









4.6.4 Enabling Siren Activation upon Telephone Line Failure

Here you determine whether the siren will be activated or not when the telephone line fails during system armed state. Available options are: **enable on fail, disable on fail** (default).



To Enable Siren Activation upon Telephone Line Failure

1. 
2.  
3.   or 

Repeat steps 1 to 4 of section 4.2 "Entering the Installer Menu".

- 4.  

- 5.   or 
- 6.  

Select between "disable on fail" and "enable on fail".

You can now press the  or  button to program any other menu in "DEFINE PANEL" or press the  button to take you to "<OK> TO EXIT".





















4.7 Event Reporting Configuration







4.7.1 General

The PowerMaster-10 system uses an IP platform that supports GSM and GPRS cellular communication and broadband to forward all events received at the control panel to the monitoring station.

4.7.2 Setup Report Communicators



4.7.2.1 Configuring PSTN / GSM Communicators

1. Repeat steps 1 to 4 of section 4.2 "Entering the Installer Menu".

2.  
3.  
4.  **TEL. AREA CODE** Enter the system tel. area code (up to 4 digits).
5.  
6.  
7.  **LINE PREFIX** Enter the number that is used as a prefix to access an outside telephone line (if exists).
8.  
9.  
10.  
11.   or  Select between "Pulse" and "tone (dtmf)".

12. 
DIAL METHOD
13. 
GSM KEEP ALIVE
14. 
disable
15.  or 
16. 
GSM KEEP ALIVE













Here you prevent the GSM Service provider from disconnecting the GSM line if the user has not initiated any outgoing telephone calls during the last 28 days.

Select between "disable" and "every 28 days".



























You can now press the  button to revert to the "AI EA CODE" menu, or press the  button to take you to "<OK> TO EXIT".











4.7.2.2 Configuring GPRS / BB Communicators

The GSM/GPRS module is capable of communicating with the Monitoring station receiver by GPRS, GSM Voice and SMS Channels. Each of the channels can be separately enabled or disabled in order to allow or prohibit the module from using it for the event reporting. If all channels are enabled, the GSM/GPRS module will always try GPRS first. If fails, it will try GSM voice. If fails, it will try any other possible method (PSTN Broadband) and only then it will try SMS. This is due to the fact that SMS the most unreliable option of communication. Disabling any of the GSM Module channels will cause the module to use a different sequence than the one described above.

1. Repeat steps 1 to 4 of section 4.2 "Entering the Installer Menu".
DEFINE COMM.
2. 
1: PSTN/GSM
3. 
2: GSM/GPRS
4. 
GPRS REPORT
5. 
disable
6.  or  Select between "disable" and "enable".
7. 
GPRS REPORT
8. 
GSM REPORT
9. 
disable
10.  or  Select between "disable" and "enable".
11. 

12. GSM REPORT
 SMS REPORT
Here you determine whether the alarm system will report events to the Monitoring Station via the SMS Channel.
13. | OK
disable
14. or Select between "disable" and "enable".
15. | OK
SMS REPORT
16. GPRS APN
17. | OK
18. APN NAME Enter the name of the APN Access Point used for the internet settings for the GPRS (up to 40 digits).
Note: The table at the end of this section provides a list of the keys used by the PowerMaster-10 editor.
19. | OK
GPRS APN
20. GPRS USERNAME
21. | OK
22. APN USERNAME Enter the username of the APN used for GPRS communications (up to 30 digits).
Note: The table at the end of this section provides a list of the keys used by the PowerMaster-10 editor.
23. | OK
GPRS USERNAME
24. GPRS PASSWORD
25. | OK
26. APN PASSWORD Enter the password of the APN used for GPRS communications (up to 16 digits).
Note: The table at the end of this section provides a list of the keys used by the PowerMaster-10 editor.
27. | OK
GPRS PASSWORD
28. PIN CODE
29. | OK
30. PIN CODE Enter the PIN code of the SIM card installed in the PowerMaster-10 unit (up to 16 digits).
31. | OK

32.     Here you determine whether to force the SIM card to use the home network only and not to select another network in case the home network cannot be found.
33.    Select between "disable" and "enable".
34.   or 
35.   
36.    Here you determine whether the control panel will stay continuously connected via GPRS communication, or, temporarily connected to receive event reports only.
37.    Select between "off on timeout" and "always ON".
38.   or 
39.   
- You can now press the  button to take you to the "GPRS REPORT" menu, or press the  button to take you to "<OK> TO EXIT".*

Key	Functionality
	Moves the cursor from left to right. Long press for speed.
	Moves the cursor from right to left. Long press for speed.
	Scrolls upward the sequence of inserted digits. Long press for speed.
	Scrolls downward the sequence of inserted digits. Long press for speed.
	Places cursor to extreme right position of edit string and shows the last 16 digits of edit string.
	Reverts to previous or top menu without saving the edit string.
	Reverts to "<OK> TO EXIT" without saving the edit string.
	Saves and reverts to previous menu.
	Clears all digits to the right of cursor.
	Clears one digit by cursor.
	Selects between uppercase or lowercase digits.

4.7.3 Configuring Event Reporting to Monitoring Station.

Here you determine which types of event will be reported to Monitoring Stations. Due to lack of space in the display, abbreviations are used: alarm is "alarm", alert is "alert" and open/close is "o/c". The asterisk (*) is a

separator between events reported to **Monitoring Station 1** and events reported to **Monitoring Station 2**. Messages are divided by type into the following groups:

Group	Abbr.	Events Reported
Alarms	alm	Fire, Burglary, Panic, Tamper
Open/close	o/c	Arming AWAY, Arming HOME, Disarming
Alerts	Alrt	No-activity, Emergency, Latchkey
Maintenance	-	Low-battery AC failure

"Alarm" group has the highest priority and "Alert" group has the lowest priority. The selectable options are as follows:

Plan name	Sent to center 1	Sent to center 2
"all -o/c γ backup"	All but open/close	All but open/close if center 1 doesn't respond
"all γ all"	All	All
"all-o/c γ all -o/c "	All but open/close	All but open/close
"all -o/c γ o/c "	All but open/close	Open/close
"all (-alrt) γ alrt"	All but alerts	Alerts
"alm γ all (-alm)"	Alarms	All but alarms
"disable report"	Nothing	Nothing
"all γ backup"	All	All if cent. 1 doesn't respond

Note: "All" means that all 4 groups are reported and also trouble messages - sensor / system low battery, sensor inactivity, power failure, jamming, communication failure etc.

4.7.3.1 Configuring the Types of Events to be Reported

- Repeat steps 1 to 4 of section 4.2 "Entering the Installer Menu".

2. 

3. 

4. 

5. 

6. 

7.  Select between "all-o/c* backup", "all *all", "all-o/c*all-o/c", "all-o/c*o/c", "all(-alrt)*alrt", "alm*all(-alm)", "disable report" and "all *backup".

































8. 

You can now press the  button to take you to the "1st RPRT METHOD" menu, or press the  button to take you to "<OK> TO EXIT".

4.7.3.2 Configuring the Communicators Report Sequence

Continue below from the previous section or repeat steps 1 to 4 of section 4.7.3.1 before continuing with the

following instructions:

- 1. 

- 2. 

- 3.  or 
- 4. 

- 5. 

- 6. 

- 7.  or 
- 8. 

- 9. 

- 10. 

- 11.  or 
- 12. 

- 13. 

- 14. 

- 15.  or 
- 16. 

Here you define the 1st priority of method used to report events.

Select between "disable", "cellular", "broadband" and "PSTN".

Here you define the 2nd priority method used to report events. If the method defined to report events in the 1st priority fails, the control panel will attempt to report using the method defined in the 2nd priority.

Select between "disable", "cellular", "broadband" and "PSTN".

Here you define the 3rd priority method used to report events. If the method defined to report events in the 2nd priority fails, the control panel will attempt to report using the method defined in the 3rd priority.

Select between "disable", "cellular", "broadband" and "PSTN".

















Here you determine whether to report events using PSTN and cellular at the same time instead of waiting for the 1st method to fail before trying the 2nd method.

Select between "disable", "PSTN & broadband", and "PSTN & cellular".

You can now press the  button to take you o the "RCVR 1 ACCOUNT#" menu, or press the  button to take you to "<OK> TO EXIT".

4.7.3.3 Configuring Account Numbers to be Reported to the Monitoring Station

Continue below from the previous section or repeat steps 1 to 4 of section 4.7.3.1 before continuing with the following instructions:













- REPORT EVENTS
1.   or  
RCVR 1 ACCOUNT# Here you enter the number that will identify your specific alarm control system to the 1st Monitoring Station. The number consists of 6 hexadecimal digits.
 2.  
1st acc. #001234
 3.  1st RCVR ACC. NO. Enter the first receiver account number.
 4.  
RCV 1 ACCOUNT#
 5.  
RCV 2 ACCOUNT# Here you enter the number that will identify your system to the 2nd Monitoring Station. The account number consists of 6 hexadecimal digits.
 6.  
2nd acc. #001234
 7.  2nd RCVR ACC. NO. Enter the second receiver account number.
 8.  
RCV 2 ACCOUNT#

















You can now press the  button to take you to the "PSTN/GSM RCVR 1" menu, or press the  button to take you to "<OK> TO EXIT".

4.7.3.4 Configuring the Monitoring Station's Telephone Numbers and IP Addresses

This mode allows you to adapt the telephone communication parameters to the local requirements.

Continue below from the previous section or repeat steps 1 to 4 of section 4.7.3.1 before continuing with the following instructions:

- REPORT EVENTS
1.   or  
PSTN/GSM RCVR 1 Here you program the telephone number of the 1st Monitoring Station (including area code, 16 digit max.) to which the system will report the event groups defined in Report Events.
 2.  
 Enter the telephone number of the first PSTN/GSM receiver (for further details see the table at the end of this section).
 3.  
PSTN/GSM RCVR 1
 4.  
PSTN/GSM RCVR 2 Here you program the telephone number of the 2nd Monitoring Station (including area code, 16 digit max.) to which the system will report the event groups defined in Report Events.
 5.  

6.  
 PSTN/GSM RCVR 2
7. 
 IP RCVR 1
8. 
 000.000.000.000
9. 
 IP RCVR 1
10. 
 IP RCVR 2
11. 
 000.000.000.000
12. 
 IP RCVR 2
13. 
 SMS RCVR1
14. 

15. 
 SMS RCVR1
16. 
 SMS RCVR2
17. 

18. 
 SMS RCVR2

Enter the telephone number of the second PSTN/GSM receiver (for further details see the table at the end of this section).

Here you enter the IP address of the IP receiver that is located in the 1st Monitoring Station.

Enter the IP address of the first IP receiver (for further details see the table at the end of this section).

Here you enter the IP address of the IP receiver that is located in the 2nd Monitoring Station.



Enter the IP address of the second IP receiver (for further details see the table at the end of this section).

Here you enter the telephone number of the SMS receiver that is located in the 1st Monitoring Station.

Enter the telephone number of the first SMS receiver (for further details see the table at the end of this section).

Here you enter the telephone number of the SMS receiver that is located in the 2nd Monitoring Station.

Enter the telephone number of the second SMS receiver (for further details see the table at the end of this section).

You can now press the  button to take you to the "PSTN REPORT FORMAT" menu, or press the  button to take you to "<OK> TO EXIT".

**Compatible Monitoring Station receivers are:
 Osborne-Hoffman model 2000, Ademco Model 685, FBII Model CP220, Radionics Model D6500, Surgard Model SG-MLR2-DG and Silent Knight Model 9500.**

IMPORTANT: In telephone number locations and account number locations, you may be required to enter hexadecimal digits. In telephone number locations, these digits are used as codes to control the dialer:

Hex.Digit	Keying Sequence	Code Significance
A	<#> ⇒ <0>	Applicable <i>only</i> at the beginning of a number - the dialer waits 10 seconds or waits for dial tone, whichever comes first and then dials.
D	<#> ⇒ <3>	Applicable <i>only</i> at the beginning of a number - the dialer waits 5 seconds for dial tone and goes on hook if none is received.
E	<#> ⇒ <4>	Applicable <i>only</i> in the middle of the number - the dialer waits 5 seconds
F	<#> ⇒ <5>	Not applicable in phone numbers

Note: A "+" can be entered at the beginning of the line by pressing # and then .

To enter a series of digits, use the following keys:
 <Numeric keypad> - to enter the number
 - moves the cursor from left to right
 - moves the cursor from right to left
 - deletes everything after the cursor (to the right)

4.7.3.5 Configuring the Report Method (Protocol) to Monitoring Station

Continue below from the previous section or repeat steps 1 to 4 of section 4.7.3.1 before continuing with the following instructions:

1. or

2. | OK

3. or

4. | OK

5.

6. | OK

7. or

8. | OK

Here you select the reporting format used by the control panel to report events to Monitoring Stations.

Select between "SIA", "4/2 1900/1400", "4/2 1800/2300", "Scancom", "SIA text" and "contact ID".

























Here you select the pulse rate at which data will be sent to Monitoring Stations if any one of the 4/2 formats has been selected in PSTN Report Format.



Select between "10 pps", "20 pps", "33 pps" and "40 pps".

You can now press the button to take you to the "PSTN RPRT RETRY" menu, or press the button to take you to "<OK> TO EXIT".

4.7.3.6 Configuring the Number of Retry Attempts







Continue below from the previous section or repeat steps 1 to 4 of section 4.7.3.1 before continuing with the following instructions:

1.   or 
 PSTN RPRT RETRY
 Here you determine the number of times the communicator will dial the Monitoring Station's number via PSTN.
2.  
 4 attempts
 Select between "2 attempts", "4 attempts", "8 attempts", "12 attempts" and "16 attempts".
3.   or 
 PSTN RPRT RETRY
4.  
 PSTN RPRT RETRY
5.  
 GSM RPRT RETRY
 Here you determine the number of times the communicator will try to report via a cellular group (GPRS, GSM and SMS) to the Monitoring Station.
6.  
 4 attempts
 Select between "2 attempts", "4 attempts", "8 attempts", "12 attempts" and "16 attempts".
7.   or 
 GSM RPRT RETRY
8.  
 GSM RPRT RETRY
9.  
 LAN RPRT RETRY
 Here you determine the number of times the communicator will try to report via the PowerLink Broadband Module communication to the Monitoring Station.
10.  
 4 attempts
 Select between "2 attempts", "4 attempts", "8 attempts", "12 attempts" and "16 attempts".
11.   or 
 LAN RPRT RETRY
12.  
 LAN RPRT RETRY

You can now press the  button to take you to the "AUTO TEST TIME" menu, or press the  button to take you to "<OK> TO EXIT".

4.7.3.7 Configuring the Auto Test Report

Continue below from the previous section or repeat steps 1 to 4 of section 4.7.3.1 before continuing with the following instructions:

1.   or 
 REPORT EVENTS
 AUTO TEST TIME
 Here you determine the time at which the telephone line will be tested and reported to the Monitoring Station.
2.  
 test time 12:00P
 Enter the auto test time.
3.  
 AUTO TEST TIME



Here you determine the time interval between consecutive telephone line test messages sent to the Monitoring Station. The control panel performs this at regular intervals to verify proper communications.



Select between "test OFF", "test every 1 d", "test every 2 d", "test every 5 d", "test every 7 d", "test every 14 d", "test every 30 d" and "test every 5 h".



Here you determine if the PSTN telephone line disconnection will be reported or not and determine the delay between detection of line disconnection and the failure reporting. If the telephone line is disconnected, the event "tel line fail" will be stored in the event log.



Select between "immediately", "5 minutes", "30 minutes", "60 minutes", "180 minutes" and "don't report".



Here you determine if the GSM/GPRS line disconnection will be reported or not and determine the delay between detection of line disconnection and report failure. If the telephone line is disconnected, the event "GSM line fail" will be stored in the event log.



Select between "2 minutes", "5 minutes", "30 minutes", "60 minutes", "180 minutes" and "don't report".





Here you determine if the PowerLink Broadband Module line disconnection will be reported or not and determine the delay between detection of line disconnection and report failure. If the telephone line is disconnected, the event "PLNK line fail" will be stored in the event log.



Select between "2 minutes", "5 minutes", "30 minutes", "60 minutes", "180 minutes" and "don't report".

20. 
broadband

21. 
LINE FAIL REPORT

You can now press the  button to take you to the *POSTN UP/DOWN* menu (see *Configuring Remote Programming Access Permissions*), or press the  button to take you to "<OK> TO EXIT".

4.7.3.8 Configuring the Event Types to be Reported to the Monitoring Station

Continue below from the previous section or repeat steps 1 to 4 of section 4.7.3.1 before continuing with the following instructions:

REPORT EVENTS

1. 
RPRT CNFRM ALARM

Here you determine whether the system will report whenever 2 or more events (**confirmed alarm**) occur during a specific period.

2. 
disable report

3. 

Select between "disable report", "enable + bypass" and "enable report".

4. 
RPRT CNFRM ALARM

5. 
RECENT CLOSE

Here you enable or disable the "recent closing" report, that is sent to the Monitoring Station if an alarm occurs within 2 minutes from the expiry of the exit delay.

6. 
recent cl. OFF

7. 

Select between "recent cl. OFF" and "recent cl. ON".

8. 
RECENT CLOSE

9. 
ZONE RESTORE

Here you determine whether a zone restore will be reported or not.

10. 
report restore







11. 

Select between "report restore" and "don't report".



12. 
ZONE RESTORE

13. 
SYS INACT REPORT

Here you determine whether the Monitoring Station will receive a message if the system is inactive (not armed) during a defined period (days).

14.  
15.   or 
16.  









Select between "disable", "rep. after 7d", " rep. after 14d ", " rep. after 30d", and "rep. after 90d".

You can now press the  button to take you to the "REPORT EVENTS" menu (see section 4.7.2.1), or press the  button to take you to "<OK> TO EXIT".

4.7.4 Configuring Event Reporting to Users

A. To Enable Report to Users

1. Repeat steps 1 to 4 of section 4.2 "Entering the Installer Menu".

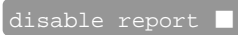
2.  
3.   or  
4.  
5.  

B. To Configure Event Types to be Reported to User

Here you determine which event groups will be reported to private telephone subscribers.

Term	Description
"all"	All messages
"all (-op/cl)"	All messages, except open/close
"all (-alerts)"	All messages, except alerts
"alarms"	Alarm messages
"alerts"	Alert messages
"op/cl"	Open/close
"disable report"	No message will be reported

Note: "All" means all events including the L. BAT and AC FAIL trouble messages.





Note: All the above options can be reported to private telephone subscribers by SMS. When Voice Report is enabled alarms and alerts only can be reported.

The following siren signal will be sent to private telephone upon event reporting:

FIRE: ON - ON - ON - pause.... (- - - - -

BURGLAR: ON continuously (————— ...)

EMERGENCY/LATCHKEY: 2-tone siren; like an ambulance.

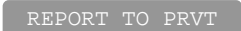
6.   or  Select between "disable report", "all", "all (-op/cl)", "all(-alerts)", "alarms", "alerts" and "op/cl".
7.  

You can now press the  button to take you to the "VOICE REPORT" menu, or press the  button to take you to "<OK> TO EXIT".

C. To Configure Event Types to be Reported to User

8. 
VOICE REPORT



9. 
1st private tel#

10. 
11.  1st PRIVATE TEL.
NO.

Enter the first private telephone number (including area code, if required) of the private subscriber to which the system will report the event groups defined in Report To Private.

12. 
1st private tel#



13. 
2nd private tel#

14. 
15.  2nd PRIVATE TEL.
NO.

Enter the second private telephone number (including area code, if required) of the private subscriber to which the system will report the event groups defined in Report To Private.

16. 
2nd private tel#



17. 
3rd private tel#

18. 
19.  3rd PRIVATE TEL.
NO.

Enter the third private telephone number (including area code, if required) of the private subscriber to which the system will report the event groups defined in Report To Private.

20. 
3rd private tel#

21. 
4th private tel#

22. 
23.  4th PRIVATE TEL.
NO.

Enter the fourth private telephone number (including area code, if required) of the private subscriber to which the system will report the event groups defined in Report To Private.

24. 
4th private tel#

25. 
Redial attempts

Here you determine the number of times the communicator will dial the called party's number (private telephone).

26. 

3 attempts

27. or

Select between "1 attempt", "2 attempts", "3 attempts" and "4 attempts".

Attention! A maximum of 2 dialing attempts is permitted by the Australian Telecommunication Authority.

28. | OK
Redial attempts

29.
Tel. acknowledge

Here you determine whether the system will use the single acknowledge or the all acknowledge mode when reporting to private telephones.

Note: In the single acknowledge mode, receiving an acknowledge signal from a single telephone is sufficient to consider the current event closed and call off the communication session. The remaining telephones serve for backup purposes only. In the all acknowledge mode, an acknowledge signal must be received from each telephone before the current event is considered reported.

30. | OK
single ack

31. or

Select between "single ack" and "all ack".

32. | OK
Tel. acknowledge

33.
VOICE REPORT

You can now press the button to take you to the "SMS REPORT TEL#" menu (see the next section), or press the button to take you to "<OK> TO EXIT".

D. To Configure Reports to User by SMS

VOICE REPORT

34.
SMS REPORT TEL#

35. | OK
1st SMS tel#

36. | OK

37. 1st SMS TEL. NO.

Enter the first SMS phone number (including area code, 16 digits max.) to which pre-selected event types will be reported.







38. | OK
1st SMS tel#



39.
2nd SMS tel#

40. | OK

41. 2nd SMS TEL. NO.

Enter the second SMS phone number (including area code, 16 digits max.) to which pre-selected event types will be reported.

42.  2nd SMS tel#
43.  3rd SMS tel#
44.  3rd SMS TEL. NO. Enter the third SMS phone number (including area code, 16 digits max.) to which pre-selected event types will be reported.
45.  3rd SMS tel#
46.  4th SMS tel#
47.  4th SMS TEL. NO. Enter the fourth SMS phone number (including area code, 16 digits max.) to which pre-selected event types will be reported.
49.  4th SMS tel#

You can now press the  button to take you to the "1st private tel#" menu (see step C. To Configure Event Types to be Reported to User), or press the  button to take you to "<OK> To EXIT".

4.8 Security System Configuration

4.8.1 Enable Cross Zoning

Here you determine whether cross zoning will be active or inactive. Cross zoning is a method used to counteract false alarms - an alarm will not be initiated unless two adjacent zones are violated within a 30-second time limit.

This feature is active only when arming AWAY and only with zone couples from zone No. 18 to 27 (18 and 19, 20 and 21, etc.). You may use any one of these zone couples to create a "cross-zoned" area.









Note: If one of two crossed zones is bypassed (see Para. 4.3.5), the remaining zone will function independently.



Note: Every 2 crossed zones must be of the allowed zone type (Interior, Perimeter, Perimeter follower).

The options are: **cross zone ON** and **cross zone OFF** (default).

Cross zoning is not applicable in Entry/ Exit zones and 24h zones (Fire, Emergency, 24h audible, 24h silent).

To Enable Cross Zoning

1.  Repeat steps 1 to 4 of section 4.2 "Entering the Installer Menu".
2.  01:ENTRY DELAY 1
3.  OR  14:CROSS ZONING
4.  cross zone OFF
5.  OR  Select between "cross zone OFF" and "cross zone ON".
6. 

You can now press the  or  button to program any other menu in "DEFINE PANEL" or press the  button to take you to "<OK> TO EXIT".

















4.8.2 Configuring Swinger Stop



Here you determine the number of times each zone is allowed to initiate an alarm within a single arming/disarming period (including tamper & power failure events of detectors, PowerMaster-10, wireless siren, etc.). If the alarms number from a specific zone exceeds the programmed number, the control panel automatically bypasses the zone to prevent recurrent siren noise and nuisance reporting to the Monitoring Station. The zone will be reactivated upon disarming, or 48 hours after having been bypassed (if the system remains armed).

Available options are: **shut after 1** (default), **shut after 2** (default in USA), **shut after 3** and **no shutdown**.

Note: To comply with EN requirements, the swinger stop should be set to 3.

To Configure Swinger Stop

1.  Repeat steps 1 to 4 of section 4.2 "Entering the Installer Menu".
2.  

3.   or 

4.  

5.   or  Select between "shut after 1", "shut after 2", "shut after 3" and "no shutdown".
6.  





You can now press the  or  button to program any other menu in "DEFINE PANEL" or press the  button to take you to "<OK> TO EXIT".









4.8.3 Enable Monitoring of Activity at Home

Here you determine the time limit for reception of signals from sensors used to monitor the activity of sick, elderly or disabled people. If no sensor detects and reports movement at least once within the defined time limit, a "not-active" alert is initiated.



Options: **3, 6, 12, 24, 48, 72 hours** and **no act disable** (default).

To Configure Monitoring of Activity at Home

1.  Repeat steps 1 to 4 of section 4.2 "Entering the Installer Menu".
2.  

3.  
4.  
5.  
6.  

Select between "no act disable", "3 h", "6 h", "12 h", "24 h", "48 h", and "72 h".

You can now press the  or  button to program any other menu in "DEFINE PANEL" or press the  button to take you to "<OK> TO EXIT".











4.8.4 Configuring Alarm Cancel Period

Here you determine the "cancel alarm" period that starts upon reporting an alarm to the Monitoring Station. If the user disarms the system within that time period, a "cancel alarm" message is sent to the Monitoring Station.

Available options are: **cancel time 1 m**, **cancel time 5 m** (default), **cancel time 15 m**, **cancel time 60 m**, **cancel time 4 hours** and also **cancel inactive** (default in USA).



Note: To comply with CP-01 requirements, "1 minute" option is not available.

To Configure the Alarm Cancel Period

1. 
2.  
3.  
4.  
5.  
6.  

Repeat steps 1 to 4 of section 4.2 "Entering the Installer Menu".

Select between "cancel time 1 m", "cancel time 5 m", "cancel time 15 m", "cancel time 60 m", "cancel time 4 h", and "cancel inactive".

You can now press the  or  button to program any other menu in "DEFINE PANEL" or press the  button to take you to "<OK> TO EXIT".













4.8.5 Configuring Power Failure Threshold Period



Here you determine the time interval between AC power failure occurrence and the failure reporting.

Options: **5 minutes** (default), **30 minutes**, **60 minutes** or **180 minutes**.

Note: To comply with EN requirements, set to 60 min. max.

To Configure the Power Failure Threshold Period

1. Repeat steps 1 to 4 of section 4.2 "Entering the Installer Menu".

2. 

3.  or 

4. 

5.  or  Select between "5 minutes", "30 minutes", "60 minutes", and "180 minutes".
6. 

You can now press the  or  button to program any other menu in "DEFINE PANEL" or press the  button to take you to "<OK> TO EXIT".

4.8.6 Configuring Abort Time











Here you select the length of time allowed by the system to abort an alarm (not applicable to alarms from FIRE, 24H SILENT and EMERGENCY zones). The PowerMaster-10 is programmed to provide an "abort interval" that starts upon detection of an event. During this interval, the buzzer sounds a warning but the siren remains inactive and the alarm is not reported. If the user disarms the system within the allowed abort interval, the alarm is aborted.

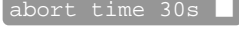

Available options are: **00s** (default in USA), **15s**, **30s** (default), **45s**, **60s**, **2m**, **3m** and **4m**.

Note: To comply with CP-01 requirements, "60s", "3m" and "4m" options are not available.

Note: To comply with UL requirements, the abort time must not exceed 45 sec.

To Configure the Abort Time

1. Repeat steps 1 to 4 of section 4.2 "Entering the Installer Menu".

2. 

3.  or 

4. 

5.  or  Select between "abort time 00s", "abort time 15s", "abort time 30s", "abort time 45s", "abort time 60s", "abort time 2m", "abort time 3m" and "abort time 4m".
6. 



You can now press the  or  button to program any other menu in "DEFINE PANEL" or press the  button to take you to "<OK> TO EXIT".











4.8.7 Configuring a Confirmed Alarm

Here you determine that if 2 successive alarms will occur during a specific period, the second alarm will be considered as a **confirmed alarm** for confirmed alarm reporting, (see par. 4.6.3.2 "Configuring the Event Types to be Reported").

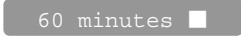
Options: **disable** (default in USA), **30 min.**, **45 min.**, **60 min.** (default), or **90 min.**

To Configure a Confirmed Alarm

1.  Repeat steps 1 to 4 of section 4.2 "Entering the Installer Menu".
 2. 













 3.  or 

 4. 

 5.  or  Select between "disable", "30 minutes", "45 minutes", "60 minutes", and "90 minutes".
 6. 

- You can now press the  or  button to program any other menu in "DEFINE PANEL" or press the  button to take you to "<OK> TO EXIT".*



4.8.8 Enable Alarm upon Detection of Jammed or Missing Device

Here you determine whether an alarm will be initiated (siren / report) when there is a supervision / jamming failure during AWAY arming state.

Available options are: **EN standard** and **other** (default). When "EN standard" is selected, if there is supervision / jamming failure during AWAY arming, the siren is activated and the events are reported as tamper events. When "Other" is selected, there is no such activity during AWAY arming.

To Enable an Alarm Upon Detection of a Jammed or Missing Device

1.  Repeat steps 1 to 4 of section 4.2 "Entering the Installer Menu".
2. 

3.  or 

4. 

5.  or  Select between "EN standard", and "other".
6. 

You can now press the  or  button to program any other menu in "DEFINE PANEL" or press the  button to take you to "<OK> TO EXIT".

4.8.9 Configuring the Jamming Detection

















Here you determine whether jamming (interfering transmissions, on the radio channel used by the system) will be detected and reported or not.



If a jam detection option is selected, the system does not allow arming under the relevant jamming conditions.

Jam Detection Options

Option	Detection and Reporting when
UL 20/20 (USA standard)	There is continuous 20 seconds of jamming
EN 30/60 (Europe standard)	There is an accumulated 30 seconds of jamming within 60 sec.
class 6 (30/60) (British standard)	Like EN (30/60) but the event will be reported only if the jamming duration exceeds 5 minutes.
Disable (default)	(No jamming detection and reporting).

To Configure the Jamming Detection

- Repeat steps 1 to 4 of section 4.2 "Entering the Installer Menu".

-  

-   or 

-  

-   or 
 Select between "UL 20/20", "EN 30/60", "class 6 (30/60)" and "disable".
-  

You can now press the  or  button to program any other menu in "DEFINE PANEL" or press the  button to take you to "<OK> TO EXIT".

4.8.10 Configuring Whether a Missing Device Causes the System to Become "NOT READY"

Here you determine if the system will be in NOT READY status when there is a supervision failure. In the "in supervision" mode, the system will be in NOT READY status if during the last 20 minutes a supervision message was not received. Options: **normal** (default) and **in supervision**.

Note: To comply with EN requirements, "in supervision" must be selected.

To Configure whether a missing device causes the system to become "NOT READY"



1. Repeat steps 1 to 4 of section 4.2 "Entering the Installer Menu".

DEFINE PANEL



2.  OK
01:ENTRY DELAY 1

3.  or 
16:NOT READY

4.  OK
normal

5.  or  Select between "normal", and "in supervision".

6.  OK
16:NOT READY

You can now press the  or  button to program any other menu in "DEFINE PANEL" or press the  button to take you to "<OK> TO EXIT".

4.8.11 Configuring the Time Period by which a Device is considered Missing

Here you determine the time limit for reception of supervision reports from various supervised wireless devices. If any device does not report at least once within the selected time limit, an "INACTIVITY" alert is initiated.

The options are: **1, 2, 4, 8, 12 hours** (default) and **disable**.

Note: To comply with EN requirements, 1 or 2 hours must be selected.

To Configure the Time Period by which a Device is Considered Missing



1. Repeat steps 1 to 4 of section 4.2 "Entering the Installer Menu".

DEFINE PANEL



2.  OK
01:ENTRY DELAY 1

3.  or 
15: SUPERVISION

4.  OK
superv time 12h

5.  or  Select between "superv time 1h", "superv time 2h", "superv time 4h", "superv time 8h", "superv time 12h" and "disable".

6.  OK
15: SUPERVISION

You can now press the  or  button to program any other menu in "DEFINE PANEL" or press the  button to take you to "<OK> TO EXIT".

4.9 Arming/Disarming Options And Exit/Entry Delay

4.9.1 Configuring Exit Modes

Here you determine exit delay mode options. Three types of exit delay modes are available:

restart exit - Exit delay restarts when the door is reopened during exit delay. The restart occurs once only. Restarting the exit delay is helpful if the user re-enters immediately after going out to retrieve an item that he left behind.

off by door - When the door is closed, the exit delay is automatically terminated (even if the defined exit delay was not completed).

normal (default) - The exit delay is exactly as defined, regardless of whether the door is open or closed.

To Configure the Exit Modes

1.

DEFINE PANEL

Repeat steps 1 to 4 of section 4.2 "Entering the Installer Menu".

2.

| OK

01:ENTRY DELAY 1

3.

or

09:EXIT MODE

4.

| OK

normal

5.

or

Select between "restart exit", "off by door", and "normal".

6.

| OK

09:EXIT MODE

You can now press the or button to program any other menu in "DEFINE PANEL" or press the button to take you to "<OK> TO EXIT".

4.9.2 Configuring Entry Delays Duration

Two different entry delays allow the user to enter the protected site (while the system is in the armed state) via 2 specific doors and routes without causing an alarm.

Following entry, the user must disarm the control panel before the entry delay expires. Slow-rate warning beeps start sounding once the door is opened, until the last 10 seconds of the delay, during which the beeping rate increases. Locations No. 1 (entry delay 1) and 2 (entry delay 2) allow you to program the length of these delays. Available options for each delay are: "00s", "15s" (default for entry delay 2), "30s" (default for entry delay 1), "45s", "60s", "3m" and "4m".

Note: To comply with CP-01 requirements, "00s" and "15s" options are not available.

Note: To comply with EN requirements, the entry delay must not exceed 45 sec.

Note: To comply with UL requirements, the entry delay must not exceed 45 sec.

To Configure the Duration of the Entry Delays

1.

DEFINE PANEL

Repeat steps 1 to 4 of section 4.2 "Entering the Installer Menu".

2.

| OK

01:ENTRY DELAY 1

*

3.





| OK

entry dly1 30s

4.   or 

Select between "entry dly1 00s", "entry dly1 15s", "entry dly1 30s", "entry dly1 45s", "entry dly1 60s", "entry dly1 3m" and "entry dly1 4m".**

5.  
09:EXIT MODE

* Press the  button for "02:ENTRY DELAY 2".
** In the "02:ENTRY DELAY 2" menu, the PowerMas ar-10 display will read "entry dly2...".
You can now press the  or  button to program any other menu in "DEFINE PANEL" or press the  button to take you to "<OK> TO EXIT".

4.9.3 Configuring Exit Delay Duration

An exit delay allows the user to arm the system and leave the protected site via specific routes and doors without causing an alarm. Slow-rate warning beeps start sounding once the arming command has been given, until the last 10 seconds of the delay, during which the beeping rate increases. Location No. 3 allows programming of the exit delay length. Available options are: **30s**, **60s** (default), **90s**, **120s**, **3m**, and **4m**.

Note: To comply with CP-01 requirements, "30s" option is not available.

Note: To comply with UL requirements, the exit delay must not exceed 120 sec.

To Configure the Exit Delay Duration

1. Repeat steps 1 to 4 of section 4.2 "Entering the Installer Menu".

DEFINE PANEL

2.  

01:ENTRY DELAY 1

3.   or 

03:EXIT DELAY

4.  



exit delay 60s

5.   or 

Select between "exit delay 30s", "exit delay 60s", "exit delay 90s", "exit delay 120s", "exit delay 3m" and "exit delay 4m".

6.  

03:EXIT DELAY

You can now press the  or  button to program any other menu in "DEFINE PANEL" or press the  button to take you to "<OK> TO EXIT".

4.9.4 Enabling Quick Arm

Here you determine whether the user will be allowed to perform quick arming or not. Once quick arming is permitted, the control panel does not request a user code before it arms the system.

The two options are: **quick arm ON** (default in USA) and **quick arm OFF** (default).

To Enable Quick Arm

1. Repeat steps 1 to 4 of section 4.2 "Entering the Installer Menu".

DEFINE PANEL

2.  OK

01:ENTRY DELAY 1

3.  or 

07:QUICK ARM

4.  OK



quick arm OFF

5.  or 

Select between "quick arm ON", and "quick arm OFF".

6.  OK

07:QUICK ARM

You can now press the  or  button to program any other menu in "DEFINE PANEL" or press the  button to take you to "<OK> TO EXIT".

4.9.5 Configuring Bypassing Zones

Here you permit either manual bypassing of individual zones (through the USER SETTINGS menu), or allow the system to "force arm" (perform automatic bypassing) of open zones during the exit delay. If desired, press the arming key again if you want to eliminate the protest tone that sounds during forced arming. If a zone is open and forced arming is not permitted, "NOT READY" is displayed and the system does not arm (the "Sad Melody" will sound). If "no bypass" is selected, neither manual bypassing nor force arming is allowed.

Options: **manual bypass** (default in USA), **force arm** and **no bypass** (default).

Note: To comply with EN requirements, "manual bypass" or "force arm" must be selected.

Note: The option "force arm" is not applicable in the UK.

To Configure Bypass

1. Repeat steps 1 to 4 of section 4.2 "Entering the Installer Menu".

DEFINE PANEL

2.  OK

01:ENTRY DELAY 1

3.  or 

08:BYPASS

4.  OK



no bypass

5.  or 

Select between "manual bypass", "force arm" and "no bypass".

6.  OK

08:BYPASS















You can now press the  or  button to program any other menu in "DEFINE PANEL" or press the  button to take you to "<OK> TO EXIT".



4.9.6 Configuring Panic Alarm Activation

Here you determine whether the user will be allowed to initiate a panic alarm by simultaneous pressing of either the two panic buttons (on the keypad / wireless commander) or away + home (on a keyfob transmitter). Audible panic activates the siren and simultaneously transmits a message via telephone. Silent panic only transmits a message via telephone.

The options are: **silent panic**, **audible panic** (default) and **disable panic**.

To Configure Panic Alarm Activation

1. Repeat steps 1 to 4 of section 4.2 "Entering the Installer Menu".

2. 

3.   or 

4. 

5.   or  Select between "silent panic", "audible panic" and "disable panic".
6. 















You can now press the  or  button to program any other menu in "DEFINE PANEL" or press the  button to take you to "<OK> TO EXIT".



4.9.7 Enabling Latchkey Arming

Here you determine whether the system can be armed in the latchkey mode. If the system is armed this way, a "latchkey" message will be sent to specific telephones upon disarming by a "latchkey user" (users 5-8 or keyfob transmitters 5-8). This mode is useful when parents at work want to be informed of a child's return from school.

The options are: **Latchkey ON** and **Latchkey OFF** (default).

To Enable Latchkey Arming

1. Repeat steps 1 to 4 of section 4.2 "Entering the Installer Menu".

2. 

3.   or 

4. 

5.   or  Select between "Latchkey ON", and "Latchkey OFF".
6. 

You can now press the  or  button to program any other menu in "DEFINE PANEL" or press the  button to take you to "<OK> TO EXIT".

4.10 User Interface Customization

4.10.1 Enabling Trouble Beeps

Under trouble conditions, the sounder emits a series of 3 short beeps once per minute. Here you determine whether this special beeping sequence will be active, inactive, or just inactive at night (the range of "night" hours is defined in the factory but is usually from 8 PM until 7 AM).

The 3 options are: **enable beeps** (default in USA), **off at night** (default) and **disable beeps**.

To Enable Trouble Beeps

1.

 DEFINE PANEL

Repeat steps 1 to 4 of section 4.2 "Entering the Installer Menu".

2.

 
01:ENTRY DELAY 1

3.

  or 
11:TROUBLE BEEPS

4.

 
off at night



5.

  or 

Select between "enable beeps", "off at night" and "disable beeps".

6.

 
11:TROUBLE BEEPS

You can now press the  or  button to program any other menu in "DEFINE PANEL" or press the  button to take you to "<OK> TO EXIT".

4.10.2 Enabling Piezo Beeps

Here you determine whether warning beeps will sound or muted during exit and entry delays. An additional option is to mute the warning beeps only when the system is armed "HOME".

Options: **enable beeps** (default), **off when home** (default in USA) and **disable beeps**.

Note: When exit beeps are disabled toward the end of a delay, the happy (success) melody will sound.

To Enable Piezo Beeps

1.

 DEFINE PANEL

Repeat steps 1 to 4 of section 4.2 "Entering the Installer Menu".

2.









 
01:ENTRY DELAY 1

3.

  or 
10:PIEZO BEEPS

4.

















- enable beeps
-   or 
 -  
- 10:PIEZO BEEPS
- Select between "enable beeps", "off when home" and "disable beeps".
- You can now press the  or  button to program any other menu in "DEFINE PANEL" or press the  button to take you to "<OK> TO EXIT".

4.10.3 Enabling the Back Light

Here you determine whether the keypad back lighting will remain on at all times or will turn on when a key is pressed and turn off within 10 seconds if no further keystrokes are sensed.

The two options are: **always ON** and **OFF after 10 s** (default).

To Enable the Back Light

- 
 -  
 -   or 
 -  
 -   or 
 -  
- Repeat steps 1 to 4 of section 4.2 "Entering the Installer Menu".
- 01:ENTRY DELAY 1
- 22:BACK LIGHT
- OFF after 10s
- Select between "OFF after 10s", and "always ON".
- 22:BACK LIGHT
- You can now press the  or  button to program any other menu in "DEFINE PANEL" or press the  button to take you to "<OK> TO EXIT".









4.10.4 Configuring the Disarm Option



Here you determine when it is possible to disarm the system:

- A. Any time.
 - B. In AWAY mode, during entry delay, by using the PowerMaster-10 keypad or wireless sensor (keyfob).
 - C. In AWAY mode, during entry delay, by using a wireless device (keyfob) only (this is set as a default in UK to comply with DD243).
 - D. During entry delay, or by using the PowerMaster-10 keypad in AWAY mode.
- Options: **any time** (default), **on entry wireless**, **entry + away kp** (default in UK), or **on entry all**.

To Configure the Disarm Option

- 
- Repeat steps 1 to 4 of section 4.2 "Entering the Installer Menu".

2.  
3.  
4.  
5.  Select between "any time", "on entry wrless", "entry + away kp" and "on entry all".
6.  

You can now press the  or  button to program any other menu in "DEFINE PANEL" or press the  button to take you to "<OK> TO EXIT".

4.10.5 Configuring the Screen Saver Options

Here you can determine that if no key is pressed during more than 30 seconds the display will read "PowerMaster-10" (to prevent a possible intruder of knowing the system status). You can determine that normal











display will return after pressing the  button followed by entering user code (**Refresh by Code**) or after pressing any key (**Refresh by Key**).



If **Refresh by Key** is selected, the first pressing of any key (except Fire and Emergency) will cause normal display return and the second press will perform the key function. Regarding the Fire and Emergency keys, the first key press will cause normal display return and also will perform the Fire/Emergency function.

Options: **scrn saver OFF** (default), **refresh by code**, **refresh by key**.

Note: To comply with EN requirements, "refresh by code" must be selected.

To Configure the Screen Saver Option

1. Repeat steps 1 to 4 of section 4.2 "Entering the Installer Menu".
2.  
3.  
4.  
5.   Select between "scrn saver OFF", "refresh by Code", and "refresh by Key".
6.  

You can now press the  or  button to program any other menu in "DEFINE PANEL" or press the  button to take you to "<OK> TO EXIT".

4.10.6 Enabling the Memory Prompt

Here you determine whether the user will receive indication that an alarm has been activated. Available options are: **enable** (default) and **disable**.

To Enable the Memory Prompt

1. Repeat steps 1 to 4 of section 4.2 "Entering the Installer Menu".

DEFINE PANEL



2.  OK
01:ENTRY DELAY 1

3.  or 
28:MEMORY PROMPT

4.  OK
enable

5.  or  Select between "enable" and "disable".

6.  OK
28:MEMORY PROMPT

You can now press the  or  button to program any other menu in "DEFINE PANEL" or press the  button to take you to "<OK> TO EXIT".

4.10.7 Enabling Keyfob Low Battery Acknowledgement

Here you determine whether the user will hear or will not hear low battery sound when he tries to disarm the system with a keyfob whose battery voltage is low.

Available options are: **keyfob L-B on** - the user has to acknowledge the keyfob low battery message, or, **keyfob L-B off** (default) - the user does not have to acknowledge the keyfob low battery message.

To Enable Keyfob Low Battery Acknowledgement

1. Repeat steps 1 to 4 of section 4.2 "Entering the Installer Menu".

DEFINE PANEL



2.  OK
01:ENTRY DELAY 1

3.  or 
31:LOW-BAT ACK

4.  OK
keyfob L-B off

5.  or  Select between "keyfob L-B on" and "keyfob L-B off".

6.  OK
31:LOW-BAT ACK

You can now press the  or  button to program any other menu in "DEFINE PANEL" or press the  button to take you to "<OK> TO EXIT".

4.11 DEFINE CUSTOM LOCATIONS

This mode allows you to define up to 5 locations (in addition to the locations that can be defined in the ZONES / DEVICES mode - see par. 4.4).

To Define Custom Locations

1. Repeat steps 1 to 4 of section 4.2 "Entering the Installer Menu".

DEFINE CUSTOM

- 2.

OK

CUST. ZONES NAME

- 3.

OK

EDIT USER TERM 1

- 4.

OK

Custom 1



Enter the first custom location.

Note: The table at the end of this section provides a list of the keys used by the PowerMaster-10 editor.















- 5.

OK

EDIT USER TERM 1

Press the  or  button and repeat the procedure for "EDIT USER TERM 2" - "EDIT USER TERM 5", as required.

Pressing the  or  buttons at any stage in the procedure will take you to "<OK> TO EXIT".

Key	Functionality
	Moves the cursor from left to right. Long press for speed.
	Moves the cursor from right to left. Long press for speed.
	Scrolls upward the sequence of inserted digits. Long press for speed.
 	Scrolls downward the sequence of inserted digits. Long press for speed.
 	Places cursor to extreme right position of edit string and shows the last 16 digits of edit string.
	Reverts to previous or top menu without saving the edit string.
	Reverts to "<OK> TO EXIT" without saving the edit string.
	Saves and reverts to previous menu.
	Clears all digits to the right of cursor.
 	Clears one digit by cursor.
	Selects between uppercase or lowercase digits.

4.12 CONFIGURING OUTPUT PARAMETERS

4.12.1 Preliminary Guidance

This mode allows you:

- Events/conditions selection under which PGM (programmable) output will function.
- Selection of the internal siren or STROBE light (that will be activated according to system programming).

4.12.2 Define PGM



For the PGM output, you can select **disable**, **turn on**, **turn off** or **pulse active** (turn on for predefined period, selected by **PULSE TIME**), as follows:

- **ARM AWAY** (upon AWAY arming).
- **ARM HOME** (upon HOME arming).
- **DISARM** (upon disarming).
- **MEMORY** (activated upon registration of an alarm in the memory, turned off upon memory clearing).
- **DELAY** (during exit / entry delays).
- **KEYFOB** (upon AUX button pressing in the keyfob transmitter).
- **ZONES** (by disturbance in each of 3 selected zones, irrespective of arming / disarming). If you select **toggle**, the PGM output will be turned on upon event occurrence in these zones and will be turned off upon next event occurrence, alternately.
- **LINE FAIL**: PGM output is ON if telephone line is disconnected.

For PGM devices, you can select the following actions:

- **FLASH ON ALARM** - you can select **no flash** or **all light flash**, to control PGM lighting devices in alarm conditions.
- **LOCKOUT TIME** - you can enter daytime limits between which PGM lighting devices controlled by sensors will be off, even when the associated sensors are triggered.

A. To Configure Output Parameters

1.  Repeat steps 1 to 4 of section 4.2 "Entering the Installer Menu".
2.  There are two sub-menus "DEFINE PGM" and "PGM GENERAL DEF". The PowerMaster-10 display will first read "DEFINE PGM".
3. 
4. 
5.  Select between "pulse time 2s", "pulse time 30s", "pulse time 2m" and "pulse time 4m"
6. 
7. 
8.  Select between "disable", "turn ON", "turn OFF" and "pulse active".
9. 
10. 
11. 
12.  Select between "disable", "turn ON", "turn OFF" and "pulse active".

13.
 PGM: BY ARM HOME

14.
 PGM: BY DISARM

15.
 disable

16. or

Select between "disable", "turn ON", "turn OFF" and "pulse active".

17.
 PGM: BY DISARM

18.
 PGM: BY MEMORY

19.
 disable

20. or

Select between "disable", "turn ON", "turn OFF" and "pulse active".

21.
 PGM: BY MEMORY

22.
 PGM: BY DELAY

23.
 disable

24. or

Select between "disable", "turn ON", "turn OFF" and "pulse active".

25.
 PGM: BY DELAY

26.
 PGM: BY KEYFOB

27.
 disable

28. or

Select between "disable", "turn ON", "turn OFF", "pulse active" and "toggle".











































29.
 PGM: BY KEYFOB

30.
 PGM: BY ZONES

31.
 a - zone

32.
 a - zone Z:00

Enter the number of the first zone that you designate for activating this output

33.   
disable
34.   or 
a - zone
35.  
a - zone
36.  
b - zone
37.  
b - zone Z:00
38.   
disable
39.   or 
b - zone
40.  
b - zone
41.  
c - zone
42.  
c - zone Z:00
43.   
disable
44.   or 
c - zone
45.  
c - zone
46.  
PGM: BY ZONES
47.  
PGM: BY LINE
48.  
by line fail NO
49.   or 
PGM: BY LINE
50.  
PGM: BY LINE

output.

Select between "disable", "turn ON", "turn OFF", "pulse active" and "toggle".

Enter the number of the second zone that you designate for activating this output.

Select between "disable", "turn ON", "turn OFF", "pulse active" and "toggle".

Enter the number of the third zone that you designate for activating this output.

Select between "disable", "turn ON", "turn OFF", "pulse active" and "toggle".

Select between "by line fail NO" and "by line failYES".

Pressing the  or  buttons at any stage in the procedure will take you to "<OK> TO EXIT".

B. To Configure PGM Lighting Devices in Alarm Conditions and To Set Daytime Limits of Lighting Devices

1. Repeat steps 1 to 4 of section 4.2 "Entering the Installer Menu".

DEFINE OUTPUTS

2.  

DEFINE PGM

3.  





PGM: GENERAL DEF

4.  

FLASH ON ALARM

5.  

no flash

6.   or   Select between "no flash" and "all light flash".

7.    

FLASH ON ALARM

8.  

LOCKOUT TIME





9.  

start - HH:MM

10.  

TIME 07:00A

Enter the time at which you wish the lockout state to begin (usually at dawn).

Note: AM and PM are selected by pressing   and  , respectively.

11.  

start - HH:MM





12.  

stop - HH:MM

13.  

TIME 07:00P

Enter the time at which you wish the lockout state to end (usually in the evening).













Note: AM and PM are selected by pressing   and  , respectively.





14.  





stop - HH:MM



Pressing the  or  buttons at any stage in the procedure will take you to "<OK> TO EXIT".





4.13 Configuring Remote Programming Access Permissions



1. Repeat steps 1 to 4 of section 4.2 "Entering the Installer Menu".

2. 

3. 

4. 

5.  or 

6. 





Here you give or deny permission to access the system and exercise control from a remote telephone.
7. 

8.  or 

Select between "rem. access ON" and "rem. access OFF"
9. 

10. 

Here you set the master installer 4-digit password for downloading/ uploading data to/from the PowerMaster-10 memory.
11. 

Enter the 4-digit master download code ("0000" is not a valid code).
12. 

13. 

Here you set the installer 4-digit password for downloading data into the PowerMaster-10 memory.
Attention! If "0000" is used, it will not enable connection of the PowerMaster-10 to the PC for upload/download purpose.
14. 

Enter the 4-digit installer download code ("0000" is not a valid code).
15. 

16. 

Here you determine whether the PowerMaster-10 data can be uploaded into a computer while the system is in disarm state or at any time (in HOME/AWAY arming & disarm state).



17. any time

18. or



Select between "any time" and "when system OFF".

Here you enter the telephone number (up to 16 digits) of the UL/DL server.

Note: Only for use of control panels monitored by compatible Monitoring Stations. Leave empty if not used.

Enter the upload/download software telephone number.

Here you enter the PowerMaster-10 SIM card telephone number. The Monitoring Station dials this number when it needs to connect to the PowerMaster-10 for uploading / downloading data.



Enter the SIM card telephone number.

Here you determine the 1st IPMP receiver telephone number. When the PowerMaster-10 responds to an incoming call from the telephone number defined here, it creates a connection to the IPMP for uploading / downloading data.



Note: Caller ID#1 / ID#2 should be 6 or more digits for wake-up by IPMP to work.

Enter the first IP receiver telephone number.

Here you determine the 2nd IPMP receiver telephone number. When the PowerMaster-10 responds to an incoming call from the telephone number defined here, it creates a connection to the IPMP for uploading / downloading data.

33. 
 2nd caller ID#
34. 
 GPRS UP / DOWN

Enter the second IP receiver telephone number.

You can now press the  button to take you to the "RPRT CNFRM ALARM" menu (see section 4.7.3.8), or press the  button to take you to "<OK> TO EXIT".

5 DIAGNOSTIC TEST

This mode allows you to test the functionality of all devices of the system and to receive / review information regarding the received signal strength. Communication between system components can also be tested and detailed information is reported.

The wireless signal strength measured and reported (see details in the drawing below).

IMPORTANT! Reliable reception must be assured during the initial testing and also throughout subsequent system maintenance. A **device should not be installed in location where signal strength is "poor"**. If you get a "poor" signal strength from a certain device, simply re-locate it and re-test until a "good" or "strong" signal strength is received. This principle should be followed throughout the diagnostic test procedure.

The diagnostic test process is shown below.

5.1 Testing Devices



This section describes how to test or review a device enrolled to the PowerMaster-10 control panel.

Note:

It is much easier to test the device while holding the device in your hand, close to the control panel.

5.1.1 Testing all Devices

1. Repeat steps 1 to 4 of section 4.2 "Entering the Installer Menu".



2. 
 WL DEVICES
3. 
 TEST ALL DEVICES
4. 
 TESTING Zxx NNN
 TEST KEYFOBS NN
- or
- ACTIVATE NOW Uxx

(or press the  button for "TEST ONE DEVICE".)

The PowerMaster-10 system will now perform automatic testing of all enrolled devices in the following order: repeaters, sensors, detectors, keypads.



The PowerMaster-10 system will perform automatic testing of keyfobs (if enrolled) at the end of testing all other devices.

Note: "Zxx" indicates the type of device and device number that is being tested. "NNN" indicates the number of devices that have not yet been tested.





At this stage if any key is pressed the PowerMaster-10 display will read "<NEXT> TO END" alternating with "<OK> TO CONTINUE". Press the  button to stop the current test and jump to the next test, or, press the  button to continue the test, or, press the  button to exit.

At the end of the testing procedure the PowerMaster-10 display will read "SHOW ALL DEVICES".

* If there are no wireless devices enrolled in the PowerMaster-10 system, the PowerMaster-10 display reads "NO DEVICES".

Pressing the  or  buttons at any stage in the procedure will take you to "<NEXT> TO END" or "<OK> TO EXIT".

5.1.2 Testing One Device

1. 
2.  
3.  
4.  
5.  
6.   or 
 Select between "CONTACT SENSORS", "MOTION SENSORS", "SMOKE SENSORS", "KEYFOBS", "SIRENS" or "REPEATERS", for example, "MOTION SENSORS".
 
7.  
 The PowerMaster-10 display will read the device name alternating with the location.
 
 
8.   or 
 (press the  or  button to select another enrolled device.)
 The PowerMaster-10 display will read "TESTING Zxx 001" or "ACTIVATE NOW Uxx" for keyfobs.
 
 
 or
 
 
 

After testing the PowerMaster-10 display will then automatically change to read the average level for the last 24 hours (for stationary devices) or the number of activations that the control panel has received (for keyfobs).

The signal strength indications are as follows: "STRONG GOOD"; "POOR"; "1-WAY" (the device operates in 1-way mode, or, the "NOW" communication test failed); "NO COM." (no communication); "NOT TST" (results are shown without any performed test); "NOT NET" (device is pre-enrolled – not networked); "NONE" (keyfob 24Hr result); or "EARLY" (result of the last 24Hrs without statistics).

Pressing the or buttons at any stage in the procedure will take you to "<OK> TO EXIT".

5.1.3 Displaying Signal Strength Indication of All Devices

1. Repeat steps 1 to 4 of section 4.2 "Entering the Installer Menu".
- 2.
- 3.
4. or
5.

















The PowerMaster-10 display switches between the average signal strength indication for the last 24 hours and the current signal strength indications of the first device type.*
6. Press the button to view the signal strength indications for the next device type.*

The signal strength indications are as follows: "STRONG GOOD"; "POOR"; "1-WAY" (the device operates in 1-way mode, or, the "NOW" communication test failed); "NO COM." (no communication); "NOT TST" (results are shown without any performed test); "NOT NET" (device is pre-enrolled – not networked); "NONE" (keyfob 24Hr result); or "EARLY" (result of the last 24Hrs without statistics).

* Pressing the button will display the number and type of device to which the signal strength indications refer.

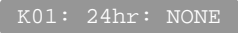

Pressing the or buttons at any stage in the procedure will take you to "<OK> TO EXIT".

5.1.4 Displaying Signal Strength Indication of RF Devices

1.  Repeat steps 1 to 4 of section 4.2 "Entering the Installer Menu".
2.   *
3.  
4.  or  
5.   The PowerMaster-10 display switches between the average signal strength indication for the last 24 hours and the current signal strength indications of the first device type.*
 
6.  Press the  button to view the signal strength indications for the next RF device type.*
  







The signal strength indications are as follows: "STRONG GOOD"; "POOR"; "1-WAY" (the device operates in 1-way mode, or, the "NOW" communication test failed); "NO COM." (no communication); "NOT TEST" (results are shown without any performed test); "NOT NET" (device is pre-enrolled – not networked); "NONE" (keyfob 24Hr result); or "EARLY" (result of the last 24Hrs without statistics).

** Pressing the  button will display the number and type of device to which the signal strength indications refer.*

Pressing the  or  buttons at any stage in the procedure will take you to "<OK> TO EXIT".

5.1.5 GPRS Communication Test

The GPRS Communication diagnostic procedure tests GSM/GPRS communication and reports the diagnostic result. In case of communication failure, detailed information of the failure is reported.

1.  Repeat steps 1 to 4 of section 4.2 "Entering the Installer Menu".
2.   *
3.  
4.  **

PLEASE WAIT...



UNIT IS OK

See the table below for a complete list of possible GSM/GPRS messages.

* If there are no wireless devices enrolled in the PowerMaster-10 system, the PowerMaster-10 display reads "NO DEVICES".

** When the **OK** button is pressed the test result takes up to 4 min. before it is displayed, depending on the severity of the failure.

Pressing the **Back** or **Home** buttons at any stage in the procedure will take you to "<OK> TO EXIT" or pressing the **Next** button at the end of the procedure will take you to the "LAN" menu.

The following GSM/ GPRS messages are reported:

Message	Description
Unit is OK	GSM / GPRS is functioning correctly.
GSM comm. loss	The GSM/GPRS module does not communicate with the Panel
Pin code fail	Missing or wrong PIN code. (Only if SIM card PIN code is enabled.)
GSM net. fail	Unit failed with registration to local GSM network.
SIM card fail	SIM not installed or SIM card failure.
GSM not detected	GSM auto enroll failed to detect GSM/GPRS module.
No GPRS service	The SIM card does not have the GPRS service enabled.
GPRS conn. fail	Local GPRS network is not available or, wrong setting to GPRS APN, user and/or password.
Srvr unavailable	IPMP Receiver cannot be reached – Check the Server IP
IP not defined	Server IP #1 and #2 are not configured.
APN not defined	APN is not configured.
SIM card locked	After entering a wrong PIN code 3 consecutive times the SIM is locked. To unlock it enter a PUK number. The PUK number cannot be entered by the PowerMaster-10.
Denied by server	The IPMP denies the connection request. Check that the Panel is registered to the IPMP Receiver.

5.1.6 LAN Connection Test

The LAN Connection diagnostic procedure tests PowerLink Broadband Module communication to the IPMP and reports the diagnostic result. In case of communication failure, detailed information of the failure is reported.

Note: If the PowerLink Broadband Module is not registered to the PowerMaster-10, the menu "LAN CONNECT .TEST" will not be displayed.



- Repeat steps 1 to 4 of section 4.2 "Entering the Installer Menu".

-
- *
- or
- **

See the table below for a complete list of possible LAN messages.

* If there are no wireless devices enrolled in the PowerMaster-10 system, the PowerMaster-10 display reads "NO DEVICES".

** When the  | OK button is pressed the test result takes up to 4 min. before it is displayed, depending on the severity of the failure.

Pressing the  or  buttons at any stage in the procedure will take you to "<OK> TO EXIT" or pressing the  button at the end of the procedure will take you to the "LAN RESET OPTION" menu.

The following LAN messages are reported:

Message	Description
Unit is ok	PowerLink Broadband Module is functioning correctly.
Test aborted	The diagnostic test is aborted, as follows: <ul style="list-style-type: none"> • AC failure – PowerLink Broadband Module is set to OFF mode. • PowerLink Broadband Module has not completed the power-up procedure. In this case, the installer should wait a maximum of 30 seconds before re-testing.
Comm. loss	The RS-232 serial interface between the PowerLink Broadband Module and the PowerMaster-10 failed.
Rcvr Ip missing	Receivers IP 1 and 2 settings are missing in the PowerMaster-10.
Cable unplugged	The Ethernet cable is not connected to the PowerLink Broadband Module.
Check lan config	This message appears in any of the following cases: <ul style="list-style-type: none"> • Incorrect PowerLink Broadband Module IP has been entered. • Incorrect subnet mask has been entered. • Incorrect default gateway has been entered. • DHCP server failure.
Rcvr#1 UnReach. Rcvr#2 UnReach.	Receiver 1 or 2 is inaccessible, as follows: <ul style="list-style-type: none"> • Wrong receiver IP has been entered. • Receiver failure. • WAN Network failure.
Rcvr#1 UnReg. Rcvr#2 UnReg.	The PowerMaster-10 unit is not registered to IP receiver 1 or 2.
Broadband Module timeout err.	PowerLink Broadband Module does not respond to test result within 70 sec.
Invalid result	PowerLink Broadband Module responds with a result code that is not recognized by the PowerMaster-10.

5.1.7 LAN Reset Option

1. Repeat steps 1 to 4 of section 4.2 "Entering the Installer Menu".



2.  | OK



*

3.  or 



4.  | OK





To reset the PowerLink Broadband Module

5.  

To reset all LAN setting definitions (does not reset Monitoring Station IP definitions)

6.  
7.  

* If there are no wireless devices enrolled in the PowerMaster-10 system, the PowerMaster-10 display reads "NO DEVICES".

Pressing the  or  buttons at any stage in the procedure will take you to "<OK> TO EXIT" or pressing the  button at the end of the procedure will take you to the "WL DEVICES" menu.









6 CALLING UPLOAD/DOWNLOAD SERVER

Note:

This option is only used during the installation of panels monitored by compatible Monitoring Stations.

This option allows the installer to initiate a call to the upload/download server. The server uploads the PowerMaster-10 configuration to its data base and can unload predefined parameters to the PowerMaster-10.

To Perform Server Upload/Download

1.  Repeat steps 1 to 4 of section 4.2 "Entering the Installer Menu".
2.  
-  If the UL/DL server telephone number was already defined (see section 4.7.3.1 "Configuring the Types of Events to be Reported"), the PowerMaster-10 display will read "COMMUNICATING" which is displayed during the dialing process.
-  If the UL/DL server telephone number was not defined (see section 4.7.3.1 "Configuring the Types of Events to be Reported"), the PowerMaster-10 display will read "TEL# NOT DEFINED" which is displayed for approx. 30 sec. and is followed by a sad (failure) tune.
-  If communication has been established between the PowerMaster-10 control panel and the upload/download server, the PowerMaster-10 display will read "DOWNLOADING" which is displayed during the dialing process.
-  If communication has failed between the PowerMaster-10 control panel and the upload/download server, the PowerMaster-10 display will read "DIAL ATTEMPT FAIL" which is displayed for approx. 30 sec. and is followed by a sad (failure) tune.
-  After the downloaded/uploaded process has been completed successfully, the PowerMaster-10 display will read "DOWNLOAD OK" which is displayed for approx. 30 sec. and is followed by a happy (success) tune.
- If communication has been established between the PowerMaster-10 control panel and the upload/download server but the downloaded/uploaded process has failed, the PowerMaster-10 display will read "DOWNLOAD FAILED" which is displayed for approx. 30 sec. and is followed by a sad (failure) tune.

7. MAINTENANCE

7.1 Handling System Troubles

Fault	What it means	Solution
1-WAY	The control panel cannot configure or control the device. Battery consumption increases.	<ul style="list-style-type: none"> i) Make sure the device is physically present. ii) Check the display for device faults, for example, low battery. iii) Use RF diagnostics to check the current signal strength and during the last 24 hours. iv) Open the device cover and replace the battery or press the tamper switch. v) Install the device in a different location. vi) Replace the device.
NOT NETWORKED	A device was not installed or not installed correctly, or, cannot establish communication with the control panel after installation.	<ul style="list-style-type: none"> i) Make sure the device is physically present. ii) Use RF diagnostics to check the current signal strength and during the last 24 hours. iii) Open the device cover and replace the battery or press the tamper switch. iv) Enroll the device again.
MISSING	A device or detector has not reported for some time to the control panel.	<ul style="list-style-type: none"> i) Make sure the device is physically present. ii) Check the display for device faults, for example, low battery. iii) Use RF diagnostics to check the current signal strength and during the last 24 hours. iv) Replace the battery. v) Replace the device.
JAMMING	A radio-frequency signal which is blocking communication channel of sensors and control panel is detected.	<p>Locate the source of interference by switching off any wireless devices (cordless telephones, wireless ear plugs, etc.) in the house for 2 minutes then check if trouble continues.</p> <p>Use also RF diagnostics to check signal strength.</p>
LOW BATTERY	The battery in a sensor, keyfob or wireless commander is near the end of its useful life.	<ul style="list-style-type: none"> i) For AC powered devices, check AC power is available and connected to the device. ii) Replace the device battery.
CLEAN ME	The fire detector must be cleaned	Use a vacuum cleaner to clean the detector air vents occasionally to keep them free of dust.
GAS TROUBLE	Gas detector failure	<p>Gas detector: Disconnect and then put back the AC power supply connector</p> <p>CO Gas detector: Replace the detector</p>

Fault	What it means	Solution
SIREN AC FAILURE	There is no power to the siren	Make sure that the AC power supply is connected properly
AC FAILURE	There is no power to gas sensor	Make sure that the AC power supply is connected properly
GSM NET FAIL	The GSM communicator is not able to connect to the cellular network.	i) Move the Panel and GSM unit to another location. ii) Enter and exit the installer menu iii) Disconnect GSM unit and install it again iv) Replace SIM card v) Replace the GSM unit
RSSI LOW	The GSM communicator has detected that GSM network signal is weak	Move the Panel and GSM unit to another location.
AC SUPPLY FAILURE	There is no power and the system is working on backup battery power	Make sure that the AC power supply is connected properly
COMM. FAILURE	A message could not be sent to the monitoring station or to a private telephone (or a message was sent but was not acknowledged)	i) Check telephone cable connection ii) Check that correct telephone number has been dialed. iii) Dial Monitoring Station to check whether or not events are received.
CPU LOW BATTERY	The backup battery within the control panel is weak and must be replaced (see Chapter 7 - Replacing Backup Battery).	i) Check for AC power is available in the Panel. ii) If trouble exists for more than 72 hours, replace the battery pack
CPU TAMPER	The control panel was physically tampered with or its cover was opened, or it was removed from wall.	The control panel is not closed properly. Open the control panel and then close it.
FUSE TROUBLE	The PGM fuse is burnt out or overloaded.	Make sure that the connection load conforms to that specified in the Specifications.
LINE FAILURE	There is a problem with the telephone line	i) Lift the telephone receiver and make sure a telephone line can be heard ii) Check the telephone connection to the control panel

7.2 Dismounting the Control Panel

- A. Remove the screw that fastens the front unit to the back unit (see Figure 3.3).
- B. Remove the 4 screws that fasten the back unit to the mounting surface (see Figure 3.3) and remove the control panel.

7.3 Replacing the Backup Battery

Replacement and first-time insertion of battery pack is similar (see Figure 3.1).

With fresh battery pack, correct insertion and tightened battery compartment lid, the TROUBLE indicator should extinguish. However, the "MEMORY" message will now blink in the display (caused by the "tamper" alarm you triggered when opening the battery compartment lid). Clear it by arming the system and immediately disarming.

7.4 Fuse Replacement

The PowerMaster-10 has an internal fuse that has automatic reset. Therefore, there is no need to replace the fuse.

When over current condition occurs, the fuse cuts off the circuit current. Upon fault current being removed for several seconds, the fuse is automatically reset and allows current flow through the circuit again.

7.5 Replacing/Relocating Detectors

Whenever maintenance work involves replacement or re-location of detectors, always perform a **full diagnostic test according to section 5**.

Remember! A "poor" signal is not acceptable, as stated at the end of the introduction to the test procedure.

7.6 Restoring Factory Defaults

If you want to reset the PowerMaster-10 parameters to the factory default parameters, you should enter the installer menu and perform the "FACTORY DEFLT" function, as detailed below. To get the relevant parameters defaults, contact the PowerMaster-10 dealer.

Note: For PowerMaster-10 with 2 installer codes, *INSTALLER code and MASTER INSTALLER code, only the master installer code enables to perform factory default function.*

To Reset PowerMaster-10 Parameters to the Factory Default Parameters

1. Repeat steps 1 to 4 of section 4.2 "Entering the Installer Menu".

FACTORY DEFLT

2.  

<OK> to restore

3.  

ENTER CODE:



The screen will now prompt you to enter your installer code.

4.  

PLEASE WAIT...

FACTORY DEFLT

The factory defaults are now restored.

You can now press the  or  buttons to take you to "<OK> TO EXIT".

7.7 Viewing the Serial Number

The menu "SERIAL NUMBER" allows reading the system serial number and panel ID for support purposes only.

Panel ID is a unique number of the control panel that is used for registering the PowerMaster-10 to IPMP when using GPRS.

To View the Serial Number

1. Repeat steps 1 to 4 of section 4.2 "Entering the Installer Menu".

SERIAL NUMBER

2.  

0907030000.

The PowerMaster-10 display will read serial number of the unit.

3.  

JSMivory 0.2.22



The PowerMaster-10 display will read the version of the unit.

4.  

Panel ID:

The PowerMaster-10 display will read the panel ID of the unit.

Pressing the  button at any stage in the procedure will take you to "SERIAL NUMBER".

Pressing the  or  buttons will take you to "<OK> TO EXIT".















8 READING THE EVENT LOG

Events are stored in the event log. You can access this log and review the events, one by one. If the event log fills up completely, the oldest event is deleted upon registration of each new event.





















The date and time of occurrence are memorized for each event.

When reading the event log, events are shown in chronological order - from the newest to the oldest. Access to the event log is provided by pressing the  button and not through the installer's menu. The reading and erasing process of the event log is shown below.

8.1 Reading the Event Log

- 
1.  While the system is in the normal operating mode, press the  key.
- 
2. Enter the current installer code.
- 
3.  

The latest event is shown.

The event is displayed in two parts, for example, "z13 alarm" then "09/02/10 3:37 P".
-  
4. Press the  button repeatedly to scroll through the list of events.
Pressing the  or  buttons at any stage in the procedure will take you to "<OK> TO EXIT".

8.2 Erasing and Exiting the Event Log

- 

5.  
From anywhere within the event log, press the  button.
Note: This is applicable only if the installer code entered.
- 
6.  

At this stage in the procedure, pressing the  or  buttons will take you to "<OK> TO EXIT" without erasing the event log. Pressing the  button will return you to "CLEAR EVENT LOG".
-  

7.  
8. 
The system erases the event log and reverts to the normal operating mode.
Pressing the  or  buttons at any stage in the procedure will take you to "<OK> TO EXIT".

APPENDIX A. Detector Deployment & Transmitter Assignments

A1. Detector Deployment Plan

Zone No.	Zone Type	Sensor Location or Transmitter Assignment (in non-alarm or emergency zones)	Chime (Yes / No)
1			
2			
3			
4			
5			
6			
7			
8			
9			
10			
11			
12			
13			
14			
15			
16			
17			
18			
19			
20			
21			
22			
23			
24			
25			
26			
27			
28			
29 (*)			
30 (*)			

Zone Types: 1 = Interior follower Ψ 2 = Perimeter Ψ 3 = Perimeter follower Ψ 4 = Delay 1 Ψ 5 = Delay 2 Ψ 6 = 24 h silent Ψ 7 = 24 h audible Ψ 8 = Non-alarm Ψ 9 = Emergency Ψ 10 = Interior Ψ 11 = Home / delay.

Zone Locations: Note down the intended location for each detector. When programming, you may select one of 26 available locations (plus 5 custom locations that you can add – see Zones Devices menu).

* Zones 29 only is hardwired zones.

A2. Keyfob Transmitter List

Transmitter Data			AUX button Assignments
No.	Type	Holder	Skip exit delay or Arming "instant"
1			Indicate the desired function (if any)
2			
3			
4			
5			
6			Skip exit delay <input type="checkbox"/>
7			Arming "instant" <input type="checkbox"/>
8			

A3. Emergency Transmitter List

Tx #	Transmitter Type	Enrolled to Zone	Name of holder
1			
2			
3			
4			
5			
6			
7			
8			
9			
10			

A4. Non-Alarm Transmitter List

Tx #	Transmitter Type	Enrolled to Zone	Name of holder	Assignment
1				
2				
3				
4				
5				
6				
7				
8				
9				
10				

APPENDIX B. Event Codes

B1. Contact ID Event Codes

Code	Definition
101	Emergency
110	Fire
120	Panic
121	Duress
122	Silent
123	Audible
131	Perimeter
132	Interior
134	Entry/Exit
137	Tamper/CP
139	Burglary verified
151	Gas alarm
154	Flood alarm
180	Gas trouble
301	AC loss
302	Low system battery
311	Battery disconnect
313	Engineer reset
321	Bell
344	RF receiver jam detect
350	Communication trouble

Code	Definition
351	Telco fault
373	Fire detector trouble
381	Loss of supervision RF
383	Sensor tamper
384	RF low battery
393	Fire detector clean me
401	O/C by user
403	Auto arm
406	Cancel
408	Quick arm
426	Door open event
441	Armed home
454	Fail to close
455	Fail to arm
456	Partial arm
459	Recent close event
570	Bypass
602	Periodic test report
607	Walk test mode
641	Senior watch trouble

B2. SIA Event Codes

Code	Definition
AR	AC Restore
AT	AC Trouble
BA	Burglary Alarm
BB	Burglary Bypass
BC	Burglary Cancel
BR	Burglary Restore
BT	Burglary Trouble / Jamming
BV	Burglary Verified
BZ	Missing Supervision
CF	Forced Closing
CI	Fail to Close
CL	Closing Report
CP	Auto Arm
CR	Recent Close
EA	Door Open
FA	Fire Alarm
FT	Fire Detector Clean
FJ	Fire detector trouble
FR	Fire Restore
GA	Gas alarm
GR	Gas alarm restore
GT	Gas trouble

Code	Definition
GJ	Gas trouble restore
HA	Holdup Alarm (duress)
LR	Phone Line Restore
LT	Phone Line Trouble
OP	Opening Report
OT	Fail to Arm
PA	Panic Alarm
QA	Emergency Alarm
RN	Engineer Reset
RP	Automatic Test
RX	Manual Test
RY	Exit from Manual Test
TA	Tamper Alarm
TR	Tamper Restore
WA	Flood alarm
WR	Flood alarm restore
XR	Sensor Battery Restore
XT	Sensor Battery Trouble
YR	System Battery Restore
YT	System Battery Trouble / Disconnection
YX	Service Required

B3. 4/2 Event Codes

Note: The report to Monitoring Station is on the following zones: First wireless siren - zone 31, second wireless siren - zone 32, GSM - zone 33.

Alarms

Zone #	1	2	3	4	5	6	7	8	9	10	11	12	13	14	15	16	17	18	19	20	21	22	23	24	25	26	27	28	29
1 st digit	4	4	4	4	4	4	4	4	4	4	4	4	4	4	4	5	5	5	5	5	5	5	5	5	5	5	5	5	5
2 nd digit	1	2	3	4	5	6	7	8	9	A	B	C	D	E	F	1	2	3	4	5	6	7	8	9	A	B	C	D	E

Restorals

Zone #	1	2	3	4	5	6	7	8	9	10	11	12	13	14	15	16	17	18	19	20	21	22	23	24	25	26	27	28	29
1 st digit	C	C	C	C	C	C	C	C	C	C	C	C	C	C	C	D	D	D	D	D	D	D	D	D	D	D	D	D	D
2 nd digit	1	2	3	4	5	6	7	8	9	A	B	C	D	E	F	1	2	3	4	5	6	7	8	9	A	B	C	D	E

Supervisory trouble

Zone #	1	2	3	4	5	6	7	8	9	10	11	12	13	14	15	16	17	18	19	20	21	22	23	24	25	26	27	28
1 st digit	6	6	6	6	6	6	6	6	6	6	6	6	6	6	6	7	7	7	7	7	7	7	7	7	7	7	7	7
2 nd digit	1	2	3	4	5	6	7	8	9	A	B	C	D	E	F	1	2	3	4	5	6	7	8	9	A	B	C	D

Low Battery

Zone #	1	2	3	4	5	6	7	8	9	10	11	12	13	14	15	16	17	18	19	20	21	22	23	24	25	26	27	28
1 st digit	8	8	8	8	8	8	8	8	8	8	8	8	8	8	8	9	9	9	9	9	9	9	9	9	9	9	9	9
2 nd digit	1	2	3	4	5	6	7	8	9	A	B	C	D	E	F	1	2	3	4	5	6	7	8	9	A	B	C	D

Forced Arming – 8 users

User No.	1	2	3	4	5	6	7	8
1 st digit	A	A	A	A	A	A	A	A
2 nd digit	1	2	3	4	5	6	7	8

Zone Bypass

Zone #	1	2	3	4	5	6	7	8	9	10	11	12	13	14	15	16	17	18	19	20	21	22	23	24	25	26	27	28	29
1 st digit	A	A	A	A	A	A	A	A	A	A	A	A	A	A	B	B	B	B	B	B	B	B	B	B	B	B	B	B	B
2 nd digit	1	2	3	4	5	6	7	8	9	A	B	C	D	E	F	1	2	3	4	5	6	7	8	9	A	B	C	D	E

Panic / 24 Hours - 8 users

User No.	1	2	3	4	5	6	7	8	Panic CP	Duress
1 st digit	2	2	2	2	2	2	2	2	2	2
2 nd digit	1	2	3	4	5	6	7	8	9	A

Arm HOME and AWAY (Closing)

User No.	1	2	3	4	5	6	7	8	Cancel alarm	Recent Close
1 st digit	E	E	E	E	E	E	E	E	E	E
2 nd digit	1	2	3	4	5	6	7	8	9	C

Disarm (Opening)

User No.	1	2	3	4	5	6	7	8
1 st digit	F	F	F	F	F	F	F	F
2 nd digit	1	2	3	4	5	6	7	8

Trouble

Event	Fuse Fail	Fuse Restore	Jamming	Jamming Restore	AC Failure	AC Restore	CPU Low Battery	CPU Low Battery Restore	CP Tamper
1 st digit	2	2	2	2	1	1	1	1	1
2 nd digit	C	D	E	F	1	2	3	4	6

Event	CP Tamper Restore	No Active	COMM. & LINE Restore	Enter Test	Exit Test	Auto Test
1 st digit	1	1	1	1	1	1
2 nd digit	7	8	A	D	E	F

B4. Understanding the Scancom Reporting Protocol Data Format

The SCANCOM data format consists of 13 decimal digits divided into 4 groups, from left to right, as shown at the right side.

Each channel is associated with a specific event as follows:

- 1st "C": Fire
- 2nd "C": Personal attack
- 3rd "C": Intruder
- 4th "C": Open/close
- 5th "C": Alarm cancel
- 6th "C": Emergency
- 7th "C": Second alarm
- 8th "C": Trouble messages

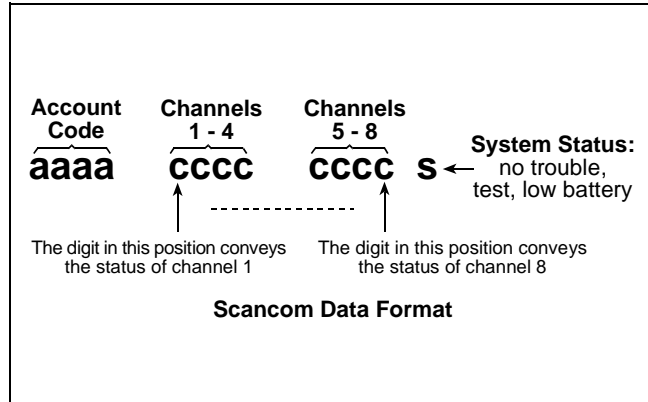

APPENDIX C. Glossary

This list of terms is arranged in alphabetical order. Any term indicated by *cursive (italic) letters* within the explanatory text can be looked up separately.

Abort Period: When an alarm is initiated, the internal sounder is activated first for a limited period of time which is the *abort period* set by the installer. If you cause an alarm accidentally, you can disarm the system within the abort period before the real sirens start and before the alarm is reported to the *remote responders*.

Alarm: There are 2 kinds of alarm:

Loud alarm - both internal and external sirens blare out constantly and the control panel reports the event by telephone.

Silent alarm - the sirens remain silent, but the control panel reports the event by telephone.

A state of alarm is caused by:

- Motion detected by a *motion detector*
- Change of state detected by a *magnetic contact detector* - a closed window or door is opened
- Detection of smoke by a *smoke detector*
- *Tampering* with any one of the detectors
- Pressing the two emergency buttons simultaneously (panic).

Arming: Arming the alarm system is an action that prepares it to sound an alarm if a zone is "violated" by motion or by opening a door or window, as the case may be. The control panel may be armed in various modes (see *AWAY, HOME, INSTANT* and *LATCHKEY*).

Assigned: Refers to zones.

Associated: Refers to devices.

AWAY: This type of arming is used when the protected site is vacated entirely. All zones, *interior* and *perimeter* alike, are protected.

Chime Zones: Allow you to keep track of activity in the protected area while the alarm system is in the disarmed state. Whenever a chime zone is "opened", the buzzer beeps twice. The buzzer doesn't beep, however, upon closing the zone (return to normal). Residences can use this feature to announce visitors or look after children. Businesses can use it to signal when customers enter the premises or when personnel enter restricted areas.

Note: *Your installer will never designate a 24-hour zone or a fire zone as a chime zone, because both zone types actuate an alarm if disturbed while the system is in the disarmed state.*

Although one zone or more are designated as chime zones, you can still enable or disable the chime function.

Communicators: Refers to communication channel, for example, GSM, PSTN and broadband.

Control Panel: The control panel is a cabinet that incorporates the electronic circuitry and microprocessor that control the alarm system. It collects information from various sensors, processes it and responds in various ways. It also includes the user-interface - control keys, numerical keypad, display, sounder and loudspeaker.

Default Settings: Settings that are applicable to a specific device group.

Detector: The device (apparatus) that sends an alarm, that communicates with the control panel (e.g. Tower 20 AM is a motion detector, MCT-425 is a smoke detector)

Disarming: The opposite of arming - an action that restores the control panel to the normal standby state. In this state, only *fire and 24-hour zones* will sound an alarm if violated, but a "*panic alarm*" may also be initiated.

Disturbed Zone: A zone in a state of alarm (this may be caused by an open window or door or by motion in the field of view of a motion detector). A disturbed zone is considered "not secured".

Forced Arming: When any one of the system zones is *disturbed* (open), the alarm system cannot be armed. One way to solve this problem is to find and eliminate the cause for zone disturbance (closing doors and windows). Another way to deal with this is to impose **forced arming** - automatic de-activation of zones that are still *disturbed* upon termination of the exit delay. Bypassed zones will not be protected throughout the arming period. Even if restored to normal (closed), bypassed zones will remain unprotected until the system is disarmed.

Permission to "force arm" is given or denied by the installer while programming the system.

HOME: This type of arming is used when people are present within the protected site. A classic example is night-time at home, when the family is about to retire to bed. With HOME arming, perimeter zones are protected but interior zones are not. Consequently, motion within interior zones will be ignored by the control panel, but disturbance of a perimeter zone will cause an alarm.

Instant: You can arm the system AWAY-INSTANT or HOME-INSTANT, thereby canceling the entry delay for all delay zones for the duration of one arming period.

For example, you may arm the control panel in the HOME-INSTANT mode and remain within the protected area. Only perimeter protection is active, and if you do not expect somebody to drop in while the system is armed, alarm upon entry via the main door is an advantage.

To disarm the system without causing an alarm, use your control keypad (which is normally accessible without disturbing a perimeter zone) or use a keyfob transmitter.

Latchkey: The Latchkey mode is a special arming mode in which designated "latchkey users" will trigger a "latchkey message" to be sent to a telephone or a pager when they disarm the system.

For example, if a parent wants to be sure that their child has returned from school and disarmed the system. Latchkey arming is only possible when the system is armed in the AWAY mode.

Location: Assigning a named location to a device (e.g. Garage, Front Door etc.)

Magnetic Contact Detector, Wireless: A Magnet-controlled switch and a wireless PowerG transmitter in a shared housing. The detector is mounted on doors and windows to detect changes in state (from closed to open and vice versa). Upon sensing that a door or window is open, the detector transmits its unique identification code accompanied by an "alarm" signal and various other status signals to the control panel.

The control panel, if not armed at that time, will consider the alarm system as "not ready for arming" until it receives a "restored" signal from the same detector.

Motion Detector, Wireless: A passive Infrared motion sensor and a wireless PowerG transmitter in a shared housing. Upon sensing motion, the detector transmits its unique identification code, accompanied by an alarm signal and various other status signals to the control panel. After transmission, it stands by to sense further motion.

Non-Alarm Zone: Your installer can designate a zone for roles other than alarm. For instance, a motion detector installed in a dark stairway may be used to switch on lights automatically when someone crosses the dark area. Another example is a miniature wireless transmitter linked to a zone that controls a gate opening mechanism.

Quick Arming: Arming without a user code. The control panel does not request your user code when you press one of the arming buttons. Permission to use this arming method is given or denied by the installer while programming the system.

Remote Responder: A responder can be either a professional service provider to which the home or business owner subscribes (*a Monitoring Station*) or a family relation/friend who agrees to look after the protected site during absence of its occupants. The *control panel* reports events by telephone to both kinds of responders.

Restore: When a detector reverts from the state of alarm to the normal standby state, it is said to have been "restored".

A *motion detector* restores automatically after detection of movement, and becomes ready to detect again. This kind of "restore" is not reported to the remote responders.

A *magnetic contact detector* restores only upon closure of the protected door or window. This kind of "restore" is reported to the remote responders.

Sensor: The sensing element: pyroelectric sensor, photo-diode, microphone, smoke optical sensor etc.

Signal Strength: The quality link communication between the system components and the control panel.

Smoke Detector, Wireless: A regular smoke detector and a wireless PowerG transmitter in a shared housing. Upon detection of smoke, the detector transmits its unique identification code accompanied by an alarm signal and various status signals to the *control panel*. Since the smoke detector is linked to a special *fire zone*, a fire alarm is initiated.

State: AWAY, HOME, AWAY-INSTANT, HOME-INSTANT, LATCHKEY, FORCED, BYPASS.

Status: AC fail, low battery, trouble, etc

User Codes: The PowerMaster-10 is designed to obey your commands, provided that they are preceded by a valid security access code.

Unauthorized people do not know this code, so any attempt on their part to *disarm* or defeat the system is bound to fail. Some operations, however, can be carried out without a user code as they do not degrade the security level of the alarm system.

Zone: A zone is an area within the protected site under supervision of a specific detector. During programming, the installer allows the *control panel* to learn the detector's identity code and links it to the desired zone. Since the zone is distinguished by number and name, the control panel can report the zone status to the user and register in its memory all the events reported by the zone detector. Instant and delay zones are "on watch" only when the control panel is armed, and other (*24-hour*) zones are "on watch" regardless of whether the system is armed or not.

Zone Type: The zone type determines how the system handles alarms and other signals sent from the device

APPENDIX D. DEFAULT AND PROGRAMMED ZONE DEFINITIONS

Zone No.	Zone Type		Location		Chime (melody Location or Off) (*)
	Default	Programmed	Default	Programmed	
1	Delay 1		Front Door		
2	Delay 1		Garage		
3	Delay 2		Garage Door		
4	Perimeter		Back Door		
5	Perimeter		Child Room		
6	Interior		Office		
7	Interior		Dining Room		
8	Perimeter		Dining Room		
9	Perimeter		Kitchen		
10	Perimeter		Living Room		
11	Interior		Living Room		
12	Interior		Bedroom		
13	Perimeter		Bedroom		
14	Perimeter		Guest Room		
15	Interior		Master Bedroom		
16	Perimeter		Master Bedroom		
17	Perimeter		Laundry Room		
18	Perimeter		Master Bathroom		
19	Perimeter		Basement		
20	24 h / audible		Fire		
21	24 h / audible		Fire		
22	Emergency		Emergency		
23	Emergency		Emergency		
24	24 h / silent		Basement		
25	24 h / silent		Office		
26	24 h / audible		Attic		
27	24 h / audible		Den		
28	non-alarm		Yard		
29	non-alarm		Hall		
30	non-alarm		Utility room		

* **Note:** All zones are CHIME OFF by default. Enter your own choice in the last column and program accordingly.

Industry Canada Declaration

This product meets the applicable Industry Canada technical specifications/Le présent matériel est conforme aux spécifications techniques applicables d'Industrie Canada.

The Ringer Equivalence Number is an indication of the maximum number of devices allowed to be connected to a telephone interface. The termination on an interface may consist of any combination of devices subject only to the requirement that the sum of the RENs of all the devices does not exceed five/L'indice d'équivalence de la sonnerie (IES) sert à indiquer le nombre maximal de terminaux qui peuvent être raccordés à une interface téléphonique. La terminaison d'une interface peut consister en une combinaison quelconque de dispositifs, à la seule condition que la somme d'indices d'équivalence de la sonnerie de tous les dispositifs n'excède pas 5.

The Ringer Equivalence Number (REN) for this terminal equipment is 0.3B.

This device complies with FCC Rules Part 15. Operation is subject to two conditions: (1) This device may not cause harmful interference, and (2) this device must accept any interference that may be received or that may cause undesired operation.

This device has been tested and found to comply with the limits for a Class B digital device, pursuant to Part 15 of the FCC Rules. These limits are designed to provide reasonable protection against harmful interference in residential installations. This equipment generates uses and can radiate radio frequency energy and, if not installed and used in accordance with the instructions, may cause harmful interference to radio and television reception.

However, there is no guarantee that interference will not occur in a particular installation. If this device does cause such interference, which can be verified by turning the device off and on, the user is encouraged to eliminate the interference by one or more of the following measures:

- Re-orient or re-locate the receiving antenna.
- Increase the distance between the device and the receiver.
- Connect the device to an outlet on a circuit different from the one that supplies power to the receiver.
- Consult the dealer or an experienced radio/TV technician.

WARNING! Changes or modifications to this unit not expressly approved by the party responsible for compliance could void the user's authority to operate the equipment.

WARRANTY

Visonic Limited (the "Manufacturer") warrants this product only (the "Product") to the original purchaser only (the "Purchaser") against defective workmanship and materials under normal use of the Product for a period of twelve (12) months from the date of shipment by the Manufacturer.

This Warranty is absolutely conditional upon the Product having been properly installed, maintained and operated under conditions of normal use in accordance with the Manufacturers recommended installation and operation instructions. Products which have become defective for any other reason, according to the Manufacturers discretion, such as improper installation, failure to follow recommended installation and operational instructions, neglect, willful damage, misuse or vandalism, accidental damage, alteration or tampering, or repair by anyone other than the manufacturer, are not covered by this Warranty.

The Manufacturer does not represent that this Product may not be compromised and/or circumvented or that the Product will prevent any death and/or personal injury and/or damage to property resulting from burglary, robbery, fire or otherwise, or that the Product will in all cases provide adequate warning or protection. The Product, properly installed and maintained, only reduces the risk of such events without warning and it is not a guarantee or insurance that such events will not occur.

THIS WARRANTY IS EXCLUSIVE AND EXPRESSLY IN LIEU OF ALL OTHER WARRANTIES, OBLIGATIONS OR LIABILITIES, WHETHER WRITTEN, ORAL, EXPRESS OR IMPLIED, INCLUDING ANY WARRANTY OF MERCHANTABILITY OR FITNESS FOR A PARTICULAR PURPOSE, OR OTHERWISE. IN NO CASE SHALL THE MANUFACTURER BE LIABLE TO ANYONE FOR ANY CONSEQUENTIAL OR INCIDENTAL DAMAGES FOR BREACH OF THIS WARRANTY OR ANY OTHER WARRANTIES WHATSOEVER, AS AFORESAID.

THE MANUFACTURER SHALL IN NO EVENT BE LIABLE FOR ANY SPECIAL, INDIRECT, INCIDENTAL, CONSEQUENTIAL OR PUNITIVE DAMAGES OR FOR LOSS, DAMAGE, OR EXPENSE, INCLUDING LOSS OF USE, PROFITS, REVENUE, OR GOODWILL, DIRECTLY OR INDIRECTLY ARISING FROM PURCHASER'S USE OR INABILITY TO USE THE PRODUCT, OR FOR LOSS OR DESTRUCTION OF OTHER PROPERTY OR FROM ANY OTHER CAUSE, EVEN IF MANUFACTURER HAS BEEN ADVISED OF THE POSSIBILITY OF SUCH DAMAGE.

THE MANUFACTURER SHALL HAVE NO LIABILITY FOR ANY DEATH, PERSONAL AND/OR BODILY INJURY AND/OR DAMAGE TO PROPERTY OR OTHER LOSS WHETHER DIRECT, INDIRECT, INCIDENTAL, CONSEQUENTIAL OR OTHERWISE, BASED ON A CLAIM THAT THE PRODUCT FAILED TO FUNCTION.

However, if the Manufacturer is held liable, whether directly or indirectly, for any loss or damage arising under this limited warranty, **THE MANUFACTURER'S MAXIMUM LIABILITY (IF ANY) SHALL NOT IN ANY CASE EXCEED THE PURCHASE PRICE OF THE PRODUCT**, which shall be fixed as liquidated damages and not as a penalty, and shall be the complete and exclusive remedy against the Manufacturer.

When accepting the delivery of the Product, the Purchaser agrees to the said conditions of sale and warranty and he recognizes having been informed of.

Some jurisdictions do not allow the exclusion or limitation of incidental or consequential damages, so these limitations may not apply under certain circumstances.

The Manufacturer shall be under no liability whatsoever arising out of the corruption and/or malfunctioning of any telecommunication or electronic equipment or any programs.

The Manufacturers obligations under this Warranty are limited solely to repair and/or replace at the Manufacturer's discretion any Product or part thereof that may prove defective. Any repair and/or replacement shall not extend the original Warranty period. The Manufacturer shall not be responsible for dismantling and/or reinstallation costs. To exercise this Warranty the Product must be returned to the Manufacturer freight pre-paid and insured. All freight and insurance costs are the responsibility of the Purchaser and are not included in this Warranty.

This warranty shall not be modified, varied or extended, and the Manufacturer does not authorize any person to act on its behalf in the modification, variation or extension of this warranty. This warranty shall apply to the Product only. All products, accessories or attachments of others used in conjunction with the Product, including batteries, shall be covered solely by their own warranty, if any. The Manufacturer shall not be liable for any damage or loss whatsoever, whether directly, indirectly, incidentally, consequentially or otherwise, caused by the malfunction of the Product due to products, accessories, or attachments of others, including batteries, used in conjunction with the Products. This Warranty is exclusive to the original Purchaser and is not assignable.

This Warranty is in addition to and does not affect your legal rights. Any provision in this warranty which is contrary to the Law in the state or country where the Product is supplied shall not apply.

Warning: The user must follow the Manufacturer's installation and operational instructions including testing the Product and its whole system at least once a week and to take all necessary precautions for his/her safety and the protection of his/her property.

1/08

The technical documentation as required by the European Conformity Assessment procedure is kept at:

UNIT 6 MADINGLEY COURT CHIPPENHAM DRIVE KINGSTON MILTON KEYNES MK10 0BZ. Telephone number: 0870 7300800, Fax number: 0870 7300801



VISONIC LTD. (ISRAEL):
VISONIC INC. (U.S.A.):

P.O.B 22020 TEL-AVIV 61220 ISRAEL. PHONE: (972-3) 645-6789, FAX: (972-3) 645-6788
65 WEST DUDLEY TOWN ROAD, BLOOMFIELD CT. 06002-1376. PHONE: (860) 243-0833, (800) 223-0020
FAX: (860) 242-8094

VISONIC LTD. (UK):

UNIT 6 MADINGLEY COURT CHIPPENHAM DRIVE KINGSTON MILTON KEYNES MK10 0BZ.
TEL: (0870) 7300800 FAX: (0870) 7300801.

VISONIC GMBH (D):

KIRCHFELDSTR. 118, D-42015 DÜSSELDORF, GERMANY, FAX (0211) 60069619 Email: info-dach@visonic.com

VISONIC IBERICA:

ISLA DE PALMA, 32 NAVE 7, POLÍGONO INDUSTRIAL NORTE, 28700 SAN SEBASTIÁN DE LOS REYES, (MADRID), ESPAÑA. TEL (34) 91659-3120, FAX (34) 91663-8468. www.visonic-iberica.es
www.visonic.com

INTERNET:

©VISONIC LTD. 2010

POWERMASTER-10 Installer Guide D-302756 Rev 2 (10/10)



MADE IN ISRAEL