

TEST REPORT

ACCORDING TO: FCC 47CFR part 15 subpart C § 15.247 (FHSS)

FOR:

Visonic Ltd.

Burglar Alarm Control Panel

Model: PowerMaster-10 G2

This report is in conformity with ISO/ IEC 17025. The "A2LA Accredited" symbol endorsement applies only to the tests and calibrations that are listed in the scope of Hermon Laboratories accreditation. The test results relate only to the items tested. This test report shall not be reproduced in any form except in full with the written approval of Hermon Laboratories Ltd.

Table of contents

1	Applicant information	3
2	Equipment under test attributes	3
3	Manufacturer information	3
4	Test details	3
5	Tests summary	4
6	EUT description	5
6.1	General information	5
6.2	Ports and lines	5
6.3	Test configuration	5
6.4	Changes made in the EUT	5
6.5	Transmitter characteristics	6
7	Transmitter tests according to 47CFR part 15 subpart C requirements	7
7.1	20 dB bandwidth	7
7.2	Carrier frequency separation	11
7.3	Number of hopping frequencies	13
7.4	Average time of occupancy	16
7.5	Peak output power	19
7.6	Band edge radiated emissions	27
7.7	Field strength of spurious emissions	32
7.8	Conducted emissions	57
7.9	Antenna requirements	60
8	APPENDIX A Test equipment and ancillaries used for tests	61
9	APPENDIX B Measurement uncertainties	62
10	APPENDIX C Test laboratory description	63
11	APPENDIX D Specification references	63
12	APPENDIX E Test equipment correction factors	64
13	APPENDIX F Abbreviations and acronyms	75

1 Applicant information

Client name: Visonic Ltd.
Address: Habarzel street 24, Tel Aviv 69710, Israel
Telephone: +972 3645 6714
Fax: +972 3645 6788
E-mail: aelshtein@visonic.com
Contact name: Mr. Arick Elshtein

2 Equipment under test attributes

Product name: Burglar alarm control panel
Product type: Transceiver
Model(s): PowerMaster-10 G2
Serial number: 3010035457
Hardware version: 90
Receipt date 12/23/2010

3 Manufacturer information

Manufacturer name: Visonic Ltd.
Address: Habarzel street 24, Tel Aviv 69710, Israel
Telephone: +972 3645 6714
Fax: +972 3645 6788
E-Mail: aelshtein@visonic.com
Contact name: Mr. Arick Elshtein

4 Test details

Project ID: 21096
Location: Hermon Laboratories Ltd. Harakevet Industrial Zone, Binyamina 30500, Israel
Test started: 12/23/2010
Test completed: 1/03/2011
Test specification(s): FCC 47CFR part 15, subpart C, §15.247 (FHSS)



5 Tests summary

Test	Status
Transmitter characteristics	
Section 15.247(a)1, The 20 dB bandwidth	Pass
Section 15.247(a)1, Frequency separation	Pass
Section 15.247(a)1, Number of hopping frequencies	Pass
Section 15.247(a)1, Average time of occupancy	Pass
Section 15.247(b), Peak output power	Pass
Section 15.247(d), Emissions at band edges	Pass
Section 15.247(d), Radiated spurious emissions	Pass
Section 15.203, Antenna requirements	Pass
Section 15.207(a), Conducted emission	Pass
Section 15.247(i), RF exposure	Pass, the exhibit to the application of certification is provided

Testing was completed against all relevant requirements of the test standard. The results obtained indicate that the product under test complies in full with the requirements tested. The test results relate only to the items tested. Pass/ fail decision was based on nominal values.

	Name and Title	Date	Signature
Tested by:	Mrs. E. Pitt, test engineer	January 3, 2011	
Reviewed by:	Mrs. M. Cherniavsky, certification engineer	January 4, 2011	
Approved by:	Mr. M. Nikishin, EMC and radio group manager	January 18, 2011	



6 EUT description

6.1 General information

The EUT, PowerMaster-10 G2 is a wireless alarm control panel of a system that provides protection against burglary, fire and tampering. In addition, it can be used to monitor the activity of disabled or elderly people left at home. Status information is presented visually. The EUT is equipped with an integral antenna.

6.2 Ports and lines

Port type	Port description	Connected from	Connected to	Qty.	Cable type	Cable length	Indoor / outdoor
Power	AC power	EUT	AC mains	1	Unshielded	1.5 m	Indoor
Telecom	PSTN	EUT	Open circuit	1	UTP	20 m	Outdoor
Signal	Phone	EUT	Open circuit	1	Unshielded	2 m	Indoor
Signal	PGM	EUT	Open circuit	2	Unshielded	2 m	Indoor
Signal	Zone	EUT	Open circuit	2	Unshielded	2 m	Indoor

6.3 Test configuration

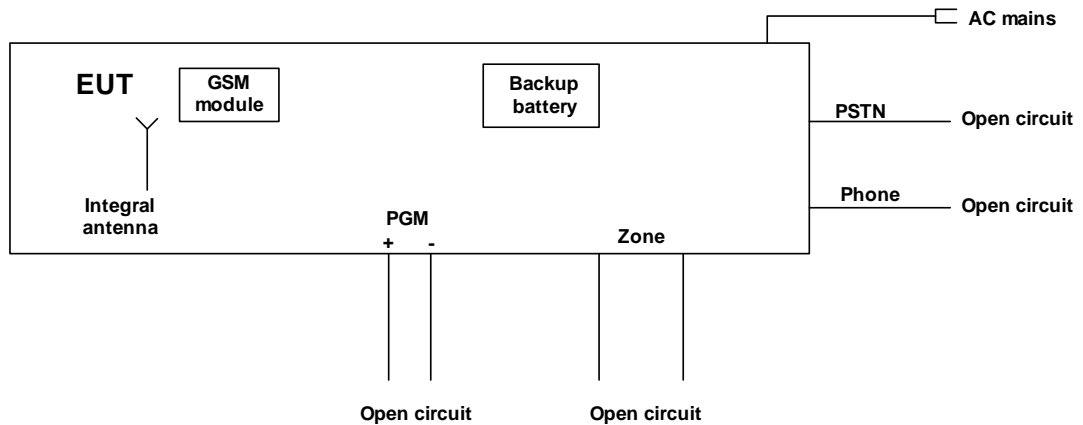

6.4 Changes made in the EUT

No changes were implemented in the EUT.

6.5 Transmitter characteristics

Type of equipment						
X	Stand-alone (Equipment with or without its own control provisions)					
	Combined equipment (Equipment where the radio part is fully integrated within another type of equipment)					
	Plug-in card (Equipment intended for a variety of host systems)					
Intended use		Condition of use				
	fixed	Always at a distance more than 2 m from all people				
X	mobile	Always at a distance more than 20 cm from all people				
	portable	May operate at a distance closer than 20 cm to human body				
Assigned frequency ranges		902 – 928 MHz				
Operating frequencies		912.750 – 919.106 MHz				
Maximum rated output power		At transmitter 50 Ω RF output connector			dBm	
		Peak output power			15.62 dBm	
Is transmitter output power variable?		X	No			
			Yes	continuous variable		
				stepped variable with stepsize		
				minimum RF power		
		maximum RF power				
				dB		
				dBm		
				dBm		
Antenna connection						
	unique coupling	standard connector	X	integral	with temporary RF connector	
					X without temporary RF connector	
Antenna/s technical characteristics						
Type	Manufacturer	Model number		Gain		
Integral	Visonic	Built-in wire antenna		-4 dBi		
Transmitter aggregate data rate/s		50 kbps				
Type of modulation		GFSK				
Modulating test signal (baseband)		PRBS				
Maximum transmitter duty cycle in normal use		0.1%				
Transmitter power source						
X	AC mains	Nominal rated voltage	120 VAC	Frequency	60 Hz	
X	Battery	Nominal rated voltage	9 VDC			
Common power source for transmitter and receiver			X	yes	no	
Spread spectrum technique used		X	Frequency hopping (FHSS)			
			Digital transmission system (DTS)			
			Hybrid			
Spread spectrum parameters for transmitters tested per FCC 15.247 only						
FHSS	Total number of hops		50			
	Bandwidth per hop		91 kHz			
	Max. separation of hops		131 kHz			

Test specification: Section 15.247(a)1, 20 dB bandwidth			
Test procedure: Public notice DA 00-705			
Test mode: Compliance	Verdict: PASS		
Date: 12/24/2010			
Temperature: 22 °C	Air Pressure: 1013 hPa	Relative Humidity: 55 %	Power Supply: 120 VAC
Remarks:			

7 Transmitter tests according to 47CFR part 15 subpart C requirements

7.1 20 dB bandwidth

7.1.1 General

This test was performed to measure 20 dB bandwidth of the transmitter hopping channel. Specification test limits are given in Table 7.1.1.

Table 7.1.1 The 20 dB bandwidth limits

Assigned frequency, MHz	Maximum bandwidth, kHz	Modulation envelope reference points*, dBc
902.0 – 928.0	500	20
2400.0 – 2483.5	NA	
5725.0 – 5850.0	1000	

* - Modulation envelope reference points provided in terms of attenuation below the peak of modulated carrier.

7.1.2 Test procedure

7.1.2.1 The EUT was set up as shown in Figure 7.1.1, energized and its proper operation was checked.

7.1.2.2 The EUT was set to transmit modulated carrier at maximum data rate.

7.1.2.3 The transmitter bandwidth was measured with spectrum analyzer as frequency delta between reference points on modulation envelope and provided in Table 7.1.2 and the associated plots.

Figure 7.1.1 The 20 dB bandwidth test setup





Test specification: Section 15.247(a)1, 20 dB bandwidth	
Test procedure: Public notice DA 00-705	
Test mode: Compliance	Verdict: PASS
Date: 12/24/2010	
Temperature: 22 °C	Air Pressure: 1013 hPa
Relative Humidity: 55 %	
Power Supply: 120 VAC	
Remarks:	

Table 7.1.2 The 20 dB bandwidth test results

ASSIGNED FREQUENCY RANGE: 902-928 MHz
DETECTOR USED: Peak
SWEEP TIME: Auto
RESOLUTION BANDWIDTH: ≥ 1% of the 20 dB bandwidth
VIDEO BANDWIDTH: ≥ RBW
MODULATION ENVELOPE REFERENCE POINTS: 20.0 dBc
FREQUENCY HOPPING: Disabled

Carrier frequency, MHz	Type of modulation	Data rate, Kbps	Symbol rate, Msymbols/s	20 dB bandwidth, kHz	Limit, kHz	Margin, kHz	Verdict
912.750	GFSK	50	NA	91.0	500	-409.0	Pass
915.863				91.0	500	-409.0	Pass
919.106				90.5	500	-409.5	Pass

Reference numbers of test equipment used

HL 0521	HL 0604	HL 2871	HL 3622				
---------	---------	---------	---------	--	--	--	--

Full description is given in Appendix A.

Test specification:	Section 15.247(a)1, 20 dB bandwidth		
Test procedure:	Public notice DA 00-705		
Test mode:	Compliance	Verdict:	PASS
Date:	12/24/2010		
Temperature: 22 °C	Air Pressure: 1013 hPa	Relative Humidity: 55 %	Power Supply: 120 VAC
Remarks:			

Plot 7.1.1 The 20 dB bandwidth test result at low frequency

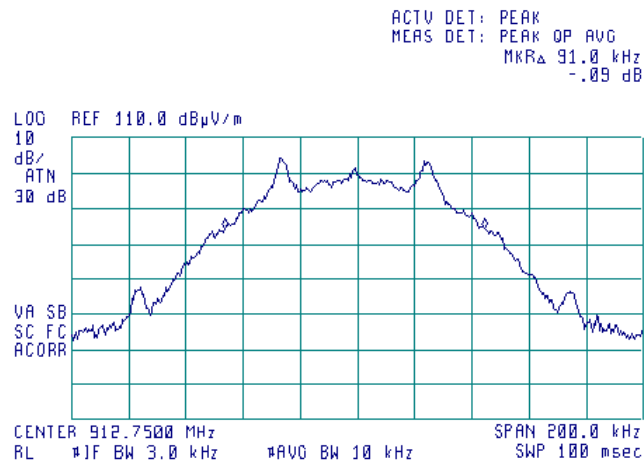

Plot 7.1.2 The 20 dB bandwidth test result at mid frequency

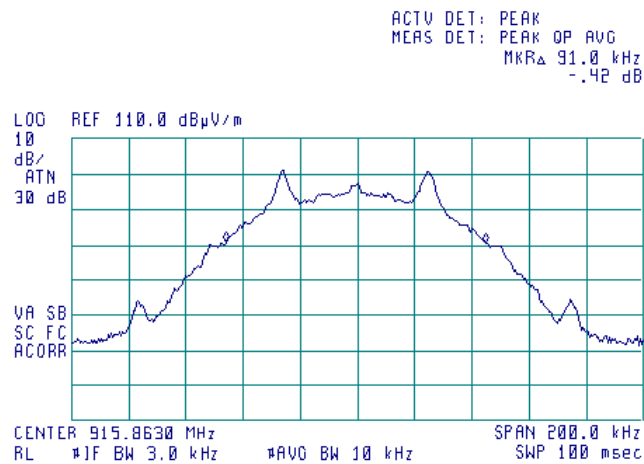



HERMON LABORATORIES

Test specification:	Section 15.247(a)1, 20 dB bandwidth		
Test procedure:	Public notice DA 00-705		
Test mode:	Compliance	Verdict:	PASS
Date:	12/24/2010		
Temperature: 22 °C	Air Pressure: 1013 hPa	Relative Humidity: 55 %	Power Supply: 120 VAC
Remarks:			

Plot 7.1.3 The 20 dB bandwidth test result at high frequency

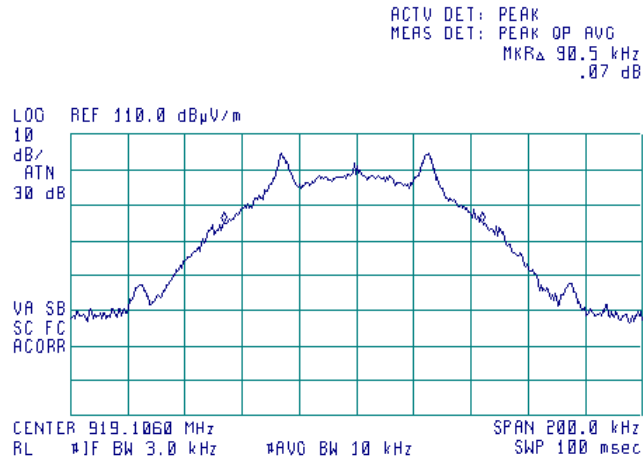

Test specification: Section 15.247(a)1, Frequency separation	
Test procedure: Public notice DA 00-705	
Test mode: Compliance	Verdict: PASS
Date: 1/3/2011	
Temperature: 22 °C	Air Pressure: 1014 hPa
Relative Humidity: 52 %	
Power Supply: 120 VAC	
Remarks:	

7.2 Carrier frequency separation

7.2.1 General

This test was performed to measure frequency separation between the peaks of adjacent channels. Specification test limits are given in Table 7.2.1.

Table 7.2.1 Carrier frequency separation limits

Assigned frequency range, MHz	Carrier frequency separation
902.0 – 928.0	25 kHz or 20 dB bandwidth of the hopping channel, whichever is greater
2400.0 – 2483.5	
5725.0 – 5850.0	

7.2.2 Test procedure

- 7.2.2.1 The EUT was set up as shown in Figure 7.2.1, energized with frequency hopping function enabled and its proper operation was checked.
- 7.2.2.2 The spectrum analyzer span was set to capture the carrier frequency and both of adjacent channels, the lower and the higher. The resolution bandwidth was set wider than 1 % of the frequency span.
- 7.2.2.3 The spectrum analyzer was set in max hold mode and allowed trace to stabilize.
- 7.2.2.4 The frequency separation between the peaks of adjacent channels was measured as provided in Table 7.2.2 and associated plots.

Figure 7.2.1 Carrier frequency separation test setup



Test specification: Section 15.247(a)1, Frequency separation			
Test procedure: Public notice DA 00-705			
Test mode: Compliance	Verdict: PASS		
Date: 1/3/2011			
Temperature: 22 °C	Air Pressure: 1014 hPa	Relative Humidity: 52 %	Power Supply: 120 VAC
Remarks:			

Table 7.2.2 Carrier frequency separation test results

ASSIGNED FREQUENCY RANGE: 902-928 MHz
 MODULATION: GFSK
 BIT RATE: 50 kbps
 DETECTOR USED: Peak
 RESOLUTION BANDWIDTH: ≥ 1% of the span
 VIDEO BANDWIDTH: ≥ RBW
 FREQUENCY HOPPING: Enabled
 20 dB BANDWIDTH: 101.3kHz

Carrier frequency separation, kHz	Limit, kHz	Margin*	Verdict
131	101.3	29.7	Pass

* - Margin = Carrier frequency separation – specification limit.

Reference numbers of test equipment used

HL 1431	HL 1984	HL 2883	HL 3386				
---------	---------	---------	---------	--	--	--	--

Full description is given in Appendix A.

Plot 7.2.1 Carrier frequency separation

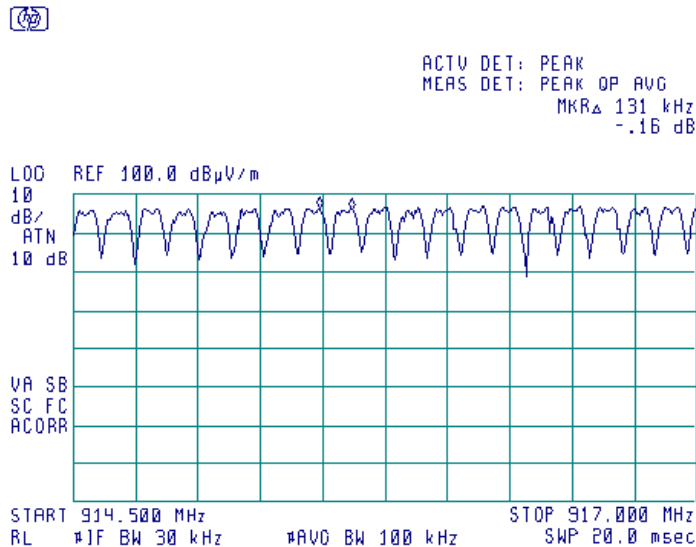

Test specification:	Section 15.247(a)1, Number of hopping frequencies		
Test procedure:	Public notice DA 00-705		
Test mode:	Compliance	Verdict:	PASS
Date:	1/3/2011		
Temperature: 22 °C	Air Pressure: 1014 hPa	Relative Humidity: 52 %	Power Supply: 120 VAC
Remarks:			

7.3 Number of hopping frequencies

7.3.1 General

This test was performed to calculate the number of hopping frequencies used by the EUT. Specification test limits are given in Table 7.3.1.

Table 7.3.1 Minimum number of hopping frequencies

Assigned frequency range, MHz	Number of hopping frequencies
902.0 – 928.0	50 (if the 20 dB bandwidth is less than 250 kHz) 25 (if the 20 dB bandwidth is 250 kHz or greater)
2400.0 – 2483.5	15
5725.0 – 5850.0	75

7.3.2 Test procedure

7.3.2.1 The EUT was set up as shown in Figure 7.3.1, energized with frequency hopping function enabled and its proper operation was checked.

7.3.2.2 Initially the spectrum analyzer span was set equal to frequency band of operation and the resolution bandwidth was set wider than 1 % of the frequency span. If the separate hopping channels were not clearly resolved the frequency band of operation was broken to sections and the resolution bandwidth was set wider than 1 % of the frequency span of each section.

7.3.2.3 The spectrum analyzer was set in max hold mode and allowed trace to stabilize.

7.3.2.4 The number of frequency hopping channels was calculated as provided in Table 7.3.2 and the associated plots.

Figure 7.3.1 Hopping frequencies test setup



Test specification: Section 15.247(a)1, Number of hopping frequencies			
Test procedure: Public notice DA 00-705			
Test mode: Compliance	Verdict: PASS		
Date: 1/3/2011			
Temperature: 22 °C	Air Pressure: 1014 hPa	Relative Humidity: 52 %	Power Supply: 120 VAC
Remarks:			

Table 7.3.2 Hopping frequencies test results

ASSIGNED FREQUENCY RANGE: 902-928 MHz
 MODULATION: GFSK
 BIT RATE: 50 kbps
 DETECTOR USED: Peak
 RESOLUTION BANDWIDTH: ≥ 1% of the span
 VIDEO BANDWIDTH: ≥ RBW
 FREQUENCY HOPPING: Enabled

Number of hopping frequencies	Minimum number of hopping frequencies	Margin*	Verdict
50	50	0	PASS

* - Margin = Number of hopping frequencies – Minimum number of hopping frequencies.

Reference numbers of test equipment used

HL 1431	HL 1984	HL 2883	HL 3386				
---------	---------	---------	---------	--	--	--	--

Full description is given in Appendix A.

Plot 7.3.1 Number of hopping frequencies in the frequency range 912 –914.5 MHz (fourteen)

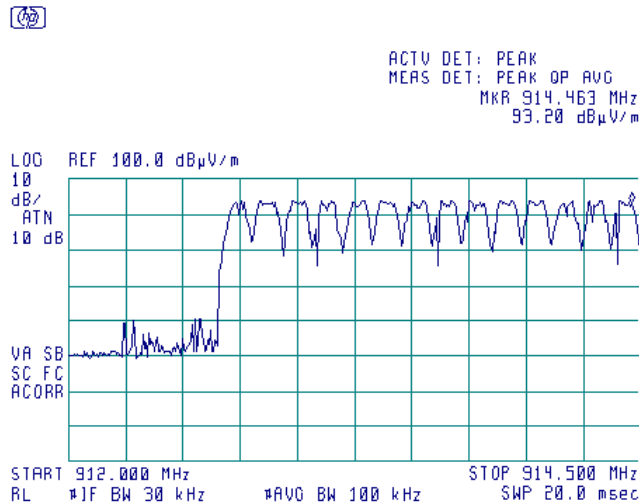

Test specification:	Section 15.247(a)1, Number of hopping frequencies		
Test procedure:	Public notice DA 00-705		
Test mode:	Compliance	Verdict:	PASS
Date:	1/3/2011		
Temperature: 22 °C	Air Pressure: 1014 hPa	Relative Humidity: 52 %	Power Supply: 120 VAC
Remarks:			

Plot 7.3.2 Number of hopping frequencies in the frequency range 914.5 –917.0 MHz (nineteen)

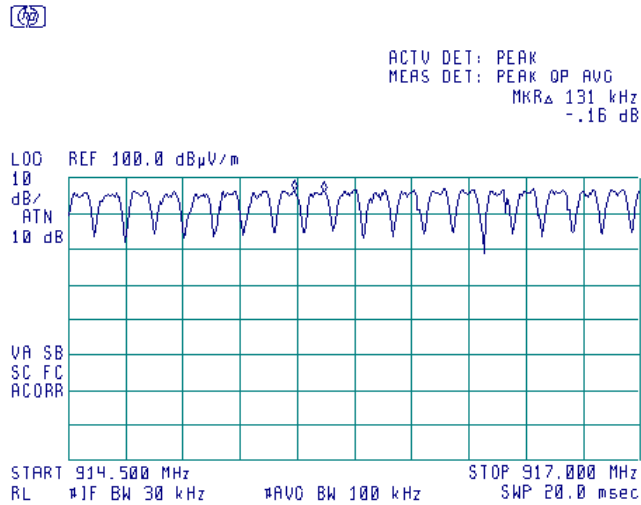

Plot 7.3.3 Number of hopping frequencies in the frequency range 917 –919.5 MHz (seventeen)

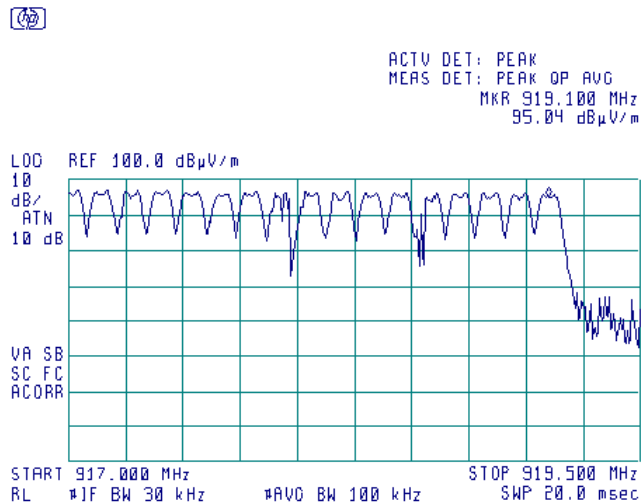

Test specification: Section 15.247(a)1, Average time of occupancy			
Test procedure: Public notice DA 00-705			
Test mode: Compliance	Verdict: PASS		
Date: 1/3/2011			
Temperature: 22 °C	Air Pressure: 1014 hPa	Relative Humidity: 52 %	Power Supply: 120 VAC
Remarks:			

7.4 Average time of occupancy

7.4.1 General

This test was performed to calculate the average time of occupancy (dwell time) on any frequency channel of the EUT. Specification test limits are given in Table 7.4.1.

Table 7.4.1 Average time of occupancy limits

Assigned frequency range, MHz	Maximum average time of occupancy, s	Investigated period, s	Number of hopping frequencies
902.0 – 928.0	0.4	20.0	≥ 50
902.0 – 928.0	0.4	10.0	< 50
2400.0 – 2483.5	0.4	0.4 × N	N (≥ 15)
5725.0 – 5850.0	0.4	30.0	≥ 75

7.4.2 Test procedure

7.4.2.1 The EUT was set up as shown in Figure 7.4.1, energized with frequency hopping function enabled and its proper operation was checked.

7.4.2.2 The spectrum analyzer span was set to zero centered on a hopping channel.

7.4.2.3 The single transmission duration and period were measured with oscilloscope.

7.4.2.4 The average time of occupancy was calculated as the single transmission time multiplied by the investigated period and divided by the single transmission period.

7.4.2.5 The test test results provided in Table 7.4.2 and the associated plots.

Figure 7.4.1 Average time of occupancy test setup

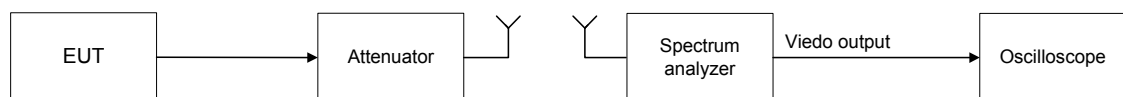

Test specification: Section 15.247(a)1, Average time of occupancy	
Test procedure: Public notice DA 00-705	
Test mode: Compliance	Verdict: PASS
Date: 1/3/2011	
Temperature: 22 °C	Air Pressure: 1014 hPa
Relative Humidity: 52 %	
Power Supply: 120 VAC	
Remarks:	

Table 7.4.2 Average time of occupancy test results

ASSIGNED FREQUENCY RANGE: 902-928 MHz
 MODULATION: GFSK
 MODULATING SIGNAL: PRBS
 DETECTOR USED: Peak
 RESOLUTION BANDWIDTH: 1 MHz
 VIDEO BANDWIDTH: 3 MHz
 NUMBER OF HOPPING FREQUENCIES: 50
 INVESTIGATED PERIOD: 20 s
 FREQUENCY HOPPING: Enabled

Carrier frequency, MHz	Single transmission duration, ms	Single transmission period, s	Average time of occupancy*, ms	Bit rate, kbps	Limit, ms	Margin, ms**	Verdict
915.863	4.35	2	43.5	50	400	-356.5	Pass

* - Average time of occupancy = (Single transmission duration × Investigated period) / (Single transmission period × number of hopping channels).

** - Margin = Average time of occupancy – specification limit.

Reference numbers of test equipment used

HL 0521	HL 0604	HL 2871	HL 3622				
---------	---------	---------	---------	--	--	--	--

Full description is given in Appendix A.

Test specification: Section 15.247(a)1, Average time of occupancy			
Test procedure: Public notice DA 00-705			
Test mode: Compliance	Verdict: PASS		
Date: 1/3/2011			
Temperature: 22 °C	Air Pressure: 1014 hPa	Relative Humidity: 52 %	Power Supply: 120 VAC
Remarks:			

Plot 7.4.1 Single transmission duration

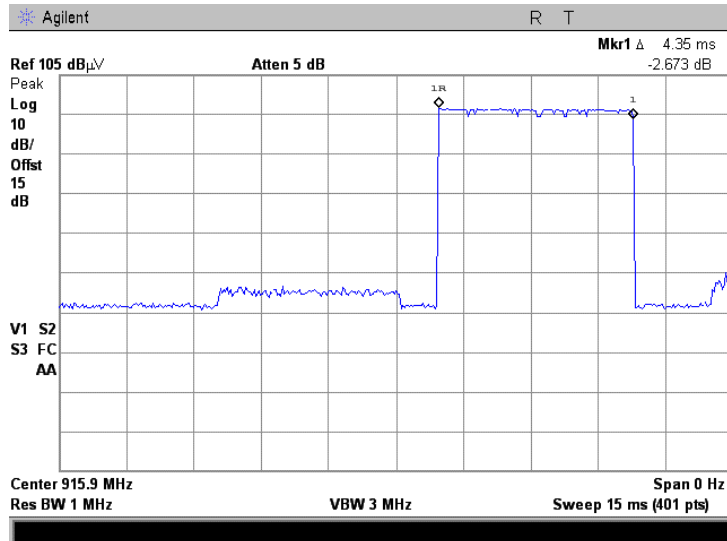

Plot 7.4.2 Single transmission period

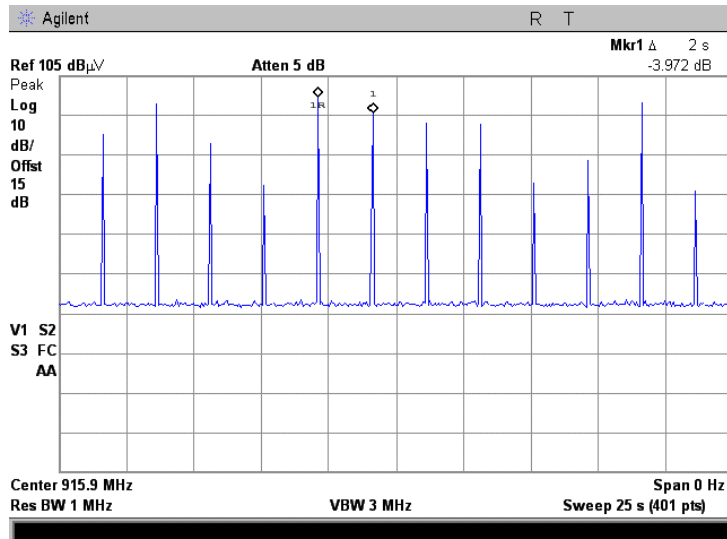

Test specification: Section 15.247(b), Peak output power	
Test procedure: Public notice DA 00-705	
Test mode: Compliance	Verdict: PASS
Date: 12/24/2010	
Temperature: 22 °C	Air Pressure: 1013 hPa
Relative Humidity: 55 %	
Power Supply: 120 VAC	
Remarks:	

7.5 Peak output power

7.5.1 General

This test was performed to measure the maximum peak output power radiated by transmitter. Specification test limits are given in Table 7.5.1.

Table 7.5.1 Peak output power limits

Assigned frequency range MHz	Peak output power*		Equivalent field strength limit @ 3m, dB(μV/m)*	Maximum antenna gain, dBi
	W	dBm		
902.0 – 928.0	1.0	30.0	131.2	6.0*
2400.0 – 2483.5	0.125 (<75 hopping channels)	21.0 (<75 hopping channels)	122.2 (<75 hopping channels)	
	1.0 (≥75 hopping channels)	30.0 (≥75 hopping channels)	131.2 (≥75 hopping channels)	
5725.0 – 5850.0	1.0	30.0	131.2	

*- Equivalent field strength limit was calculated from the peak output power as follows: $E = \sqrt{30 \times P \times G} / r$, where P is peak output power in Watts, r is antenna to EUT distance in meters and G is transmitter antenna gain in dBi.

** - The limit is provided in terms of conducted RF power at the antenna connector. If transmitting antennas of directional gain greater than 6 dBi are used, the peak output power limit shall be reduced below the stated value as follows:

- by 1 dB for every 3 dB that the directional gain of antenna exceeds 6 dBi for fixed point-to-point transmitters operate in 2400-2483.5 MHz band;
- without any corresponding reduction for fixed point-to-point transmitters operate in 5725-5850 MHz band;
- by the amount in dB that the directional gain of antenna exceeds 6 dBi for the rest of transmitters.

7.5.2 Test procedure

7.5.2.1 The EUT was set up as shown in Figure 7.5.1, energized and its proper operation was checked.

7.5.2.2 The EUT was adjusted to produce maximum available to end user RF output power.

7.5.2.3 The frequency span of spectrum analyzer was set approximately 5 times wider than 20 dB bandwidth of the EUT and the resolution bandwidth was set wider than 20 dB bandwidth of the EUT. To find maximum radiation the turntable was rotated 360° and the measuring antenna height was swept in both vertical and horizontal polarizations.

7.5.2.4 The maximum field strength of the EUT carrier frequency was measured as provided in Table 7.5.2 and associated plots.

7.5.2.5 The maximum peak output power was calculated from the field strength of carrier as follows:

$$P = (E \times d)^2 / (30 \times G),$$

where P is the peak output power in W, E is the field strength in V/m, d is the test distance and G is the transmitter numeric antenna gain over an isotropic radiator.

The above equation was converted in logarithmic units for 3 m test distance:

$$\text{Peak output power in dBm} = \text{Field strength in dB}(\mu\text{V/m}) - \text{Transmitter antenna gain in dBi} - 95.2 \text{ dB}$$

7.5.2.6 The worst test results (the lowest margins) were recorded in Table 7.5.2.

Test specification:	Section 15.247(b), Peak output power		
Test procedure:	Public notice DA 00-705		
Test mode:	Compliance	Verdict:	PASS
Date:	12/24/2010		
Temperature: 22 °C	Air Pressure: 1013 hPa	Relative Humidity: 55 %	Power Supply: 120 VAC
Remarks:			

Figure 7.5.1 Setup for carrier field strength measurements

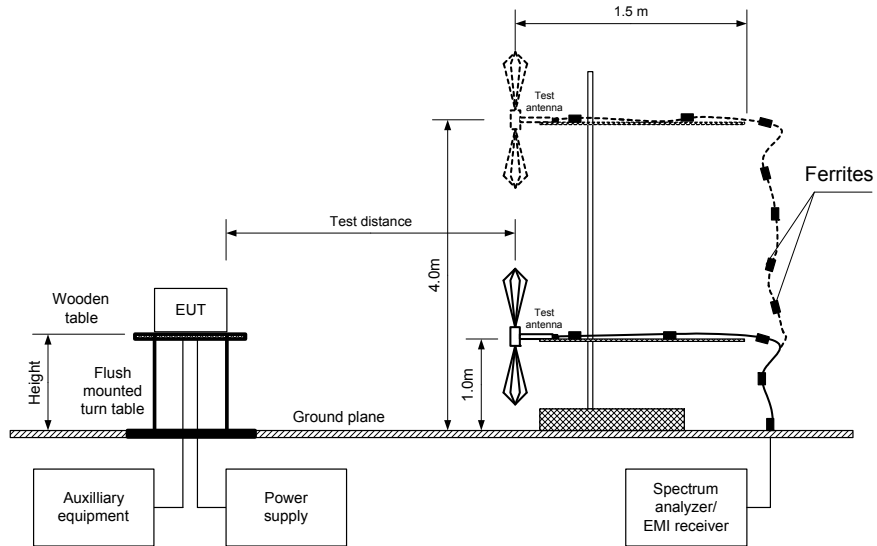

Test specification: Section 15.247(b), Peak output power	
Test procedure: Public notice DA 00-705	
Test mode: Compliance	Verdict: PASS
Date: 12/24/2010	
Temperature: 22 °C	Air Pressure: 1013 hPa
Relative Humidity: 55 %	
Power Supply: 120 VAC	
Remarks:	

Table 7.5.2 Peak output power test results

ASSIGNED FREQUENCY RANGE: 902-928 MHz
TEST DISTANCE: 3 m
TEST SITE: Semi anechoic chamber
EUT HEIGHT: 0.8 m
DETECTOR USED: Peak
TEST ANTENNA TYPE: Biconilog (30 MHz – 1000 MHz)
Double ridged guide (above 1000 MHz)
MODULATION: GFSK
BIT RATE: 50 kbps
TRANSMITTER OUTPUT POWER SETTINGS: Maximum
DETECTOR USED: Peak
EUT 20 dB BANDWIDTH: 91 kHz
RESOLUTION BANDWIDTH: 120 MHz
VIDEO BANDWIDTH: 300 MHz
FREQUENCY HOPPING: Disabled
NUMBER OF FREQUENCY HOPPING CHANNELS: 50

frequency, MHz	Field strength, dB(µV/m)	Antenna polarization	Antenna height, m	Azimuth, degrees*	EUT antenna gain, dBi	Peak output power, dBm**	Limit, dBm	Margin, dB***	Verdict
912.750	104.70	V	1.1	120	-4	14.50	30	-15.50	Pass
915.863	101.91	V	1.1	110	-4	11.71	30	-18.29	Pass
919.106	105.66	V	1.1	120	-4	15.62	30	-14.38	Pass

*- EUT front panel refer to 0 degrees position of turntable.

**- Peak output power was calculated from the field strength of carrier as follows: $P = (E \times d)^2 / (30 \times G)$, where P is the peak output power in W, E is the field strength in V/m, d is the test distance in meters and G is the transmitter numeric antenna gain over an isotropic radiator. The above equation was converted in logarithmic units for 3 m test distance: *Peak output power in dBm = Field strength in dB(µV/m) - Transmitter antenna gain in dBi - 95.2 dB*

***- Margin = Peak output power – specification limit.

Note: Maximum peak output power was obtained at Unom input power voltage.

Reference numbers of test equipment used

HL 0521	HL 0604	HL 2871	HL 3622	HL 4051			
---------	---------	---------	---------	---------	--	--	--

Full description is given in Appendix A.

Test specification:	Section 15.247(b), Peak output power		
Test procedure:	Public notice DA 00-705		
Test mode:	Compliance	Verdict:	PASS
Date:	12/24/2010		
Temperature: 22 °C	Air Pressure: 1013 hPa	Relative Humidity: 55 %	Power Supply: 120 VAC
Remarks:			

Plot 7.5.1 Field strength of carrier at low frequency and Unom

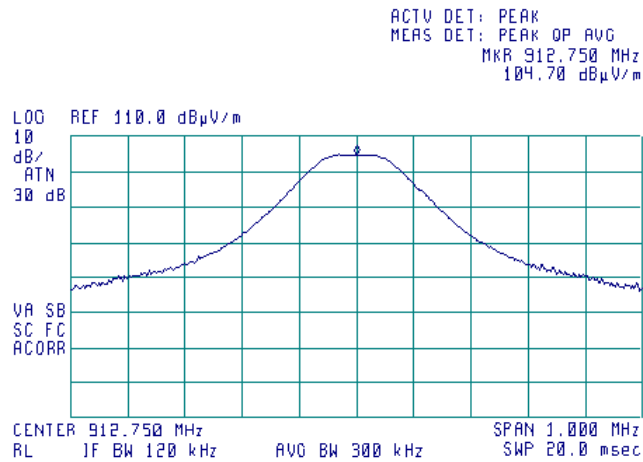

Plot 7.5.2 Field strength of carrier at mid frequency and Unom

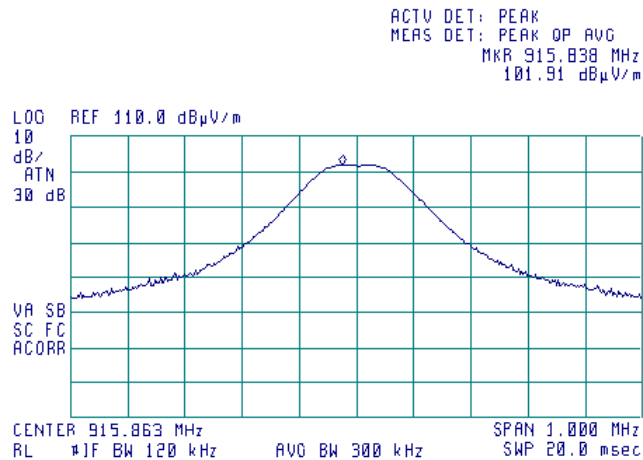

Test specification:	Section 15.247(b), Peak output power		
Test procedure:	Public notice DA 00-705		
Test mode:	Compliance	Verdict:	PASS
Date:	12/24/2010		
Temperature: 22 °C	Air Pressure: 1013 hPa	Relative Humidity: 55 %	Power Supply: 120 VAC
Remarks:			

Plot 7.5.3 Field strength of carrier at high frequency and Unom

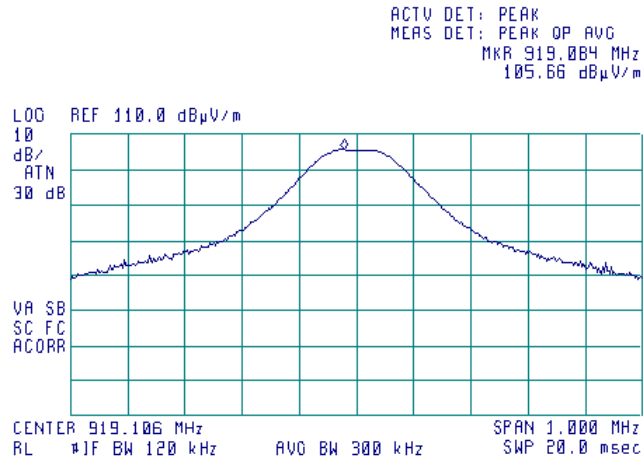

Plot 7.5.4 Peak output power at low frequency and 115%Unom

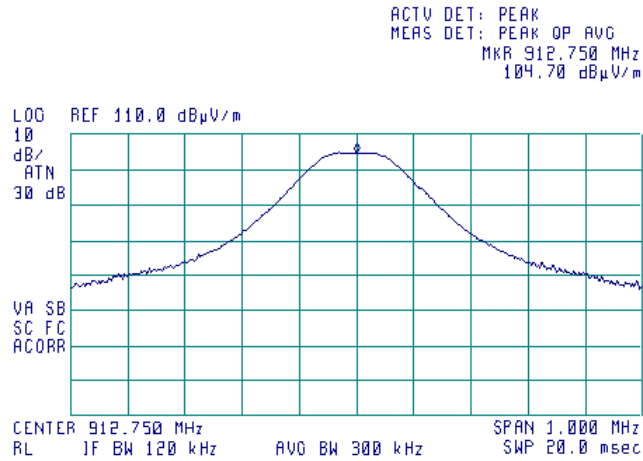

Test specification:	Section 15.247(b), Peak output power		
Test procedure:	Public notice DA 00-705		
Test mode:	Compliance	Verdict:	PASS
Date:	12/24/2010		
Temperature: 22 °C	Air Pressure: 1013 hPa	Relative Humidity: 55 %	Power Supply: 120 VAC
Remarks:			

Plot 7.5.5 Peak output power at mid frequency and 115%Unom

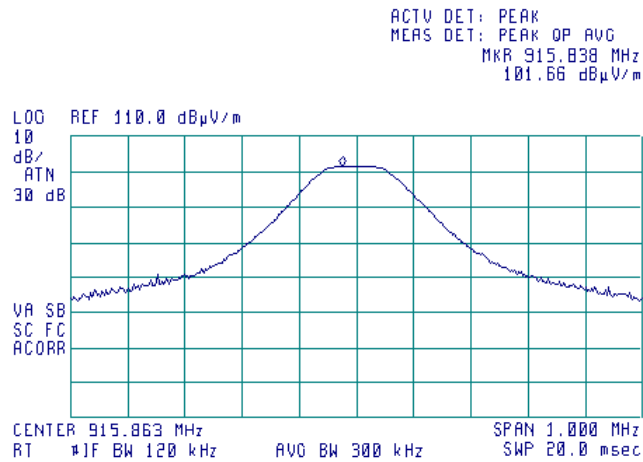

Plot 7.5.6 Peak output power at high frequency and 115%Unom

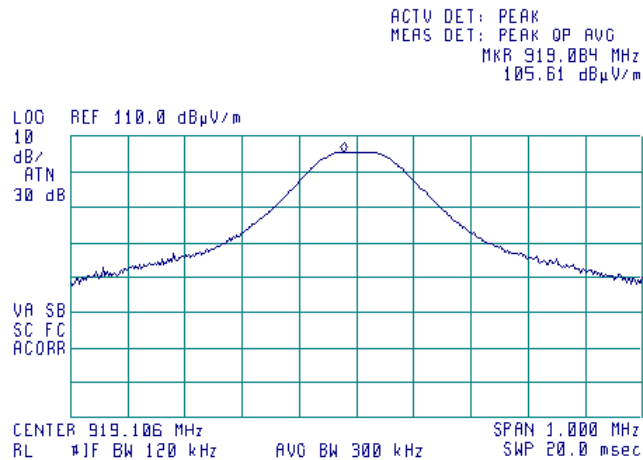

Test specification:	Section 15.247(b), Peak output power		
Test procedure:	Public notice DA 00-705		
Test mode:	Compliance	Verdict:	PASS
Date:	12/24/2010		
Temperature: 22 °C	Air Pressure: 1013 hPa	Relative Humidity: 55 %	Power Supply: 120 VAC
Remarks:			

Plot 7.5.7 Peak output power at low frequency and 85%Unom

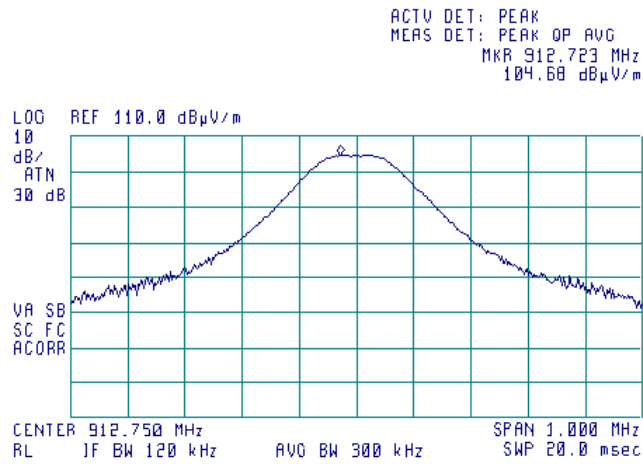

Plot 7.5.8 Peak output power at mid frequency and 85%Unom

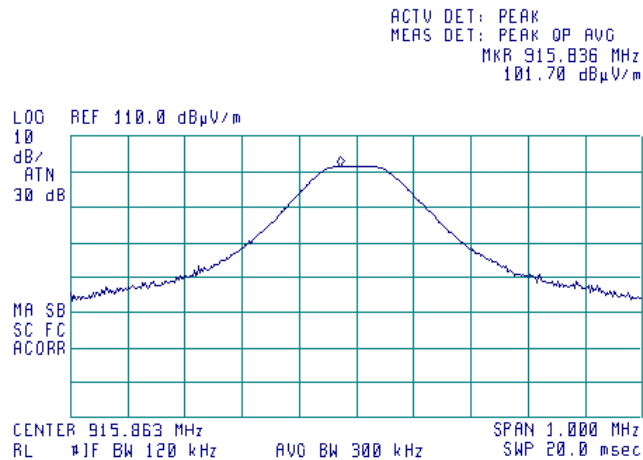



HERMON LABORATORIES

Test specification:	Section 15.247(b), Peak output power		
Test procedure:	Public notice DA 00-705		
Test mode:	Compliance	Verdict:	PASS
Date:	12/24/2010		
Temperature: 22 °C	Air Pressure: 1013 hPa	Relative Humidity: 55 %	Power Supply: 120 VAC
Remarks:			

Plot 7.5.9 Peak output power at high frequency and 85%Unom

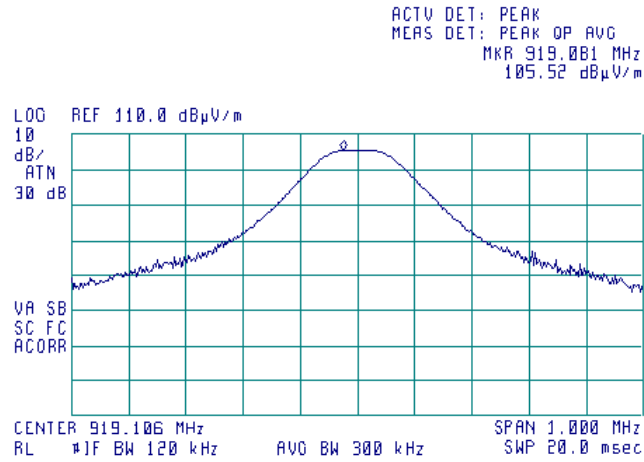

Test specification:	Section 15.247(d), Emissions at band edges		
Test procedure:	Public notice DA 00-705		
Test mode:	Compliance	Verdict:	PASS
Date:	1/3/2011		
Temperature: 22 °C	Air Pressure: 1013 hPa	Relative Humidity: 55 %	Power Supply: 120 VAC
Remarks:			

7.6 Band edge radiated emissions

7.6.1 General

This test was performed to measure emissions, radiated from the EUT at the assigned frequency band edges. Specification test limits are given in Table 7.6.1.

Table 7.6.1 Band edge emission limits

Assigned frequency, MHz	Attenuation below carrier*, dBc	Field strength at 3 m within restricted bands, dB(μ V/m)	
		Peak	Average
902.0 – 928.0	20.0	74.0	54.0
2400.0 – 2483.5			
5725.0 – 5850.0			

* - Band edge emission limit is provided in terms of attenuation below the peak of modulated carrier measured with the same resolution bandwidth.

7.6.2 Test procedure

- 7.6.2.1 The EUT was set up as shown in Figure 7.6.1, energized normally modulated at the maximum data rate with its hopping function disabled and its proper operation was checked.
- 7.6.2.2 The EUT was adjusted to produce maximum available to end user RF output power at the lowest carrier frequency.
- 7.6.2.3 The spectrum analyzer span was set to capture the carrier frequency and associated modulation products. The resolution bandwidth was set wider than 1 % of the frequency span.
- 7.6.2.4 The spectrum analyzer was set in max hold mode and allowed trace to stabilize. The highest emission level within the authorized band was measured.
- 7.6.2.5 The maximum band edge emission and modulation product outside of the band were measured as provided in Table 7.6.2 and associated plots and referenced to the highest emission level measured within the authorized band.
- 7.6.2.6 The above procedure was repeated with the EUT adjusted to produce maximum RF output power at the highest carrier frequency.
- 7.6.2.7 The above procedure was repeated with the frequency hopping function enabled.

Figure 7.6.1 Band edge emission test setup





Test specification:		Section 15.247(d), Emissions at band edges			
Test procedure:		Public notice DA 00-705			
Test mode:	Compliance	Verdict:		PASS	
Date:	1/3/2011				
Temperature: 22 °C	Air Pressure: 1013 hPa	Relative Humidity: 55 %	Power Supply: 120 VAC		
Remarks:					

Table 7.6.2 Band edge emission test results

ASSIGNED FREQUENCY RANGE: 902-928 MHz
DETECTOR USED: Peak
MODULATION: GFSK
BIT RATE: 50 kbps
TRANSMITTER OUTPUT POWER SETTINGS: Maximum
RESOLUTION BANDWIDTH: ≥ 1% of the span
VIDEO BANDWIDTH: ≥ RBW

Frequency, MHz	Band edge emission, dBm	Emission at carrier, dBm	Attenuation below carrier, dBc	Limit, dBc	Margin, dB*	Verdict
Frequency hopping disabled						
902	57.93	104.70	46.77	20.0	26.77	Pass
928	59.07	105.66	46.59		26.59	
Frequency hopping enabled						
902	38.83	104.70	65.87	20.0	45.87	Pass
928	46.31	105.66	59.35		39.35	

*- Margin = Attenuation below carrier – specification limit.

Reference numbers of test equipment used

HL 0521	HL 0604	HL 2871	HL 3622				
---------	---------	---------	---------	--	--	--	--

Full description is given in Appendix A.

Test specification: Section 15.247(d), Emissions at band edges			
Test procedure: Public notice DA 00-705			
Test mode: Compliance	Verdict: PASS		
Date: 1/3/2011			
Temperature: 22 °C	Air Pressure: 1013 hPa	Relative Humidity: 55 %	Power Supply: 120 VAC
Remarks:			

Plot 7.6.1 The highest emission level within the assigned band at low carrier frequency

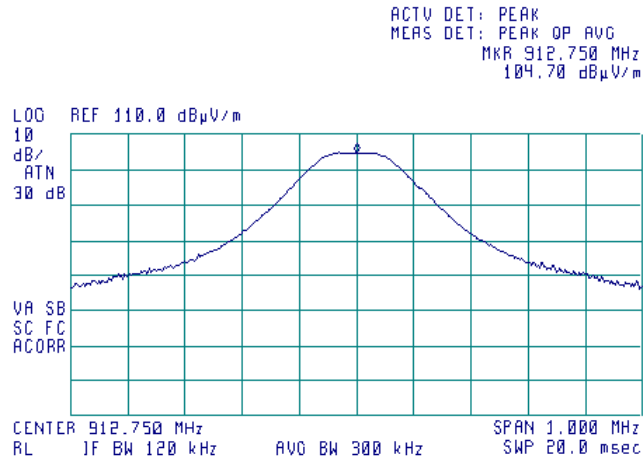

Plot 7.6.2 The highest emission level within the assigned band at high carrier frequency

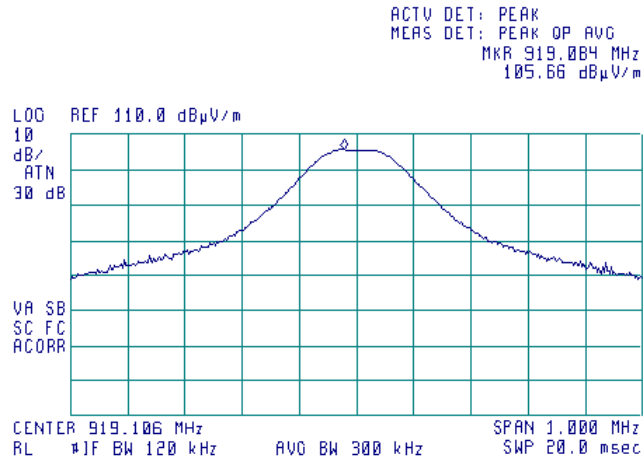

Test specification: Section 15.247(d), Emissions at band edges			
Test procedure: Public notice DA 00-705			
Test mode: Compliance	Verdict: PASS		
Date: 1/3/2011			
Temperature: 22 °C	Air Pressure: 1013 hPa	Relative Humidity: 55 %	Power Supply: 120 VAC
Remarks:			

Plot 7.6.3 The highest band edge emission at low carrier frequency with hopping function disabled

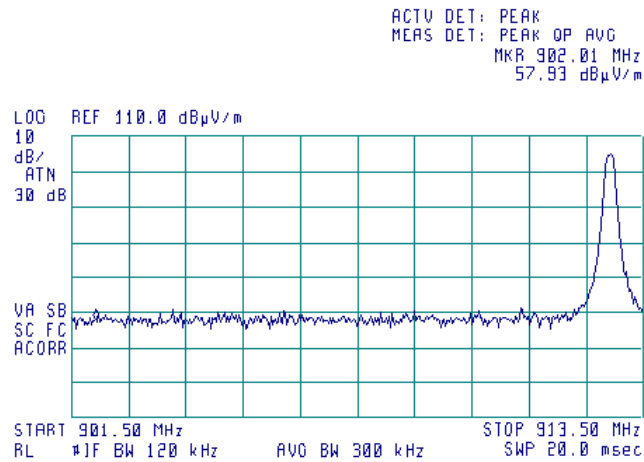

Plot 7.6.4 The highest band edge emission at high carrier frequency with hopping function disabled

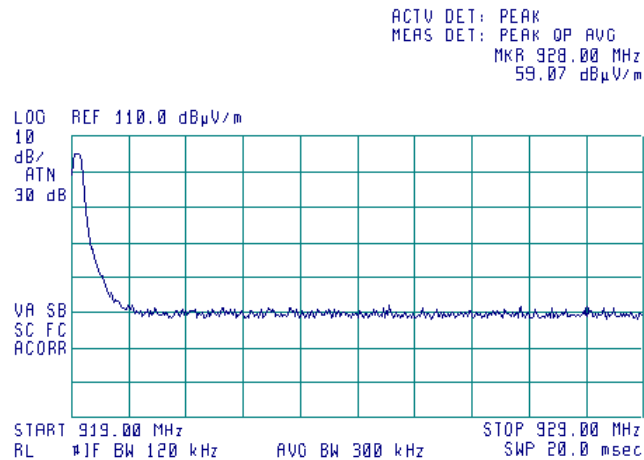

Test specification: Section 15.247(d), Emissions at band edges			
Test procedure: Public notice DA 00-705			
Test mode: Compliance	Verdict: PASS		
Date: 1/3/2011			
Temperature: 22 °C	Air Pressure: 1013 hPa	Relative Humidity: 55 %	Power Supply: 120 VAC
Remarks:			

Plot 7.6.5 The highest band edge emission at low carrier frequency with hopping function enabled

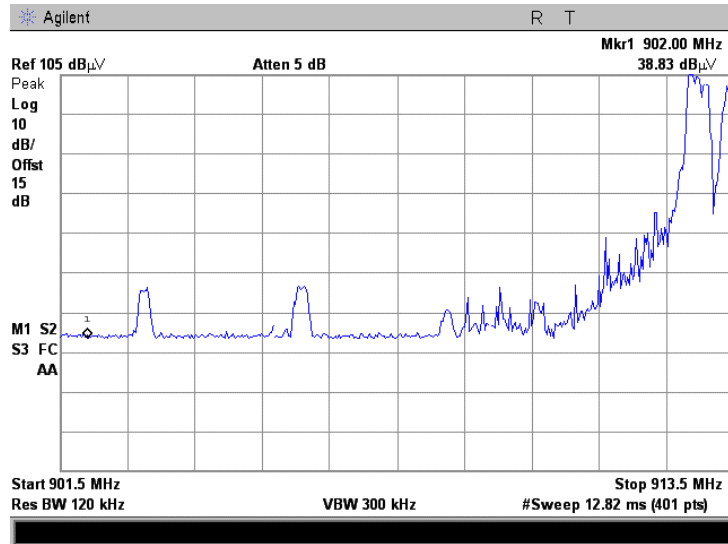

Plot 7.6.6 The highest band edge emission at high carrier frequency with hopping function enabled

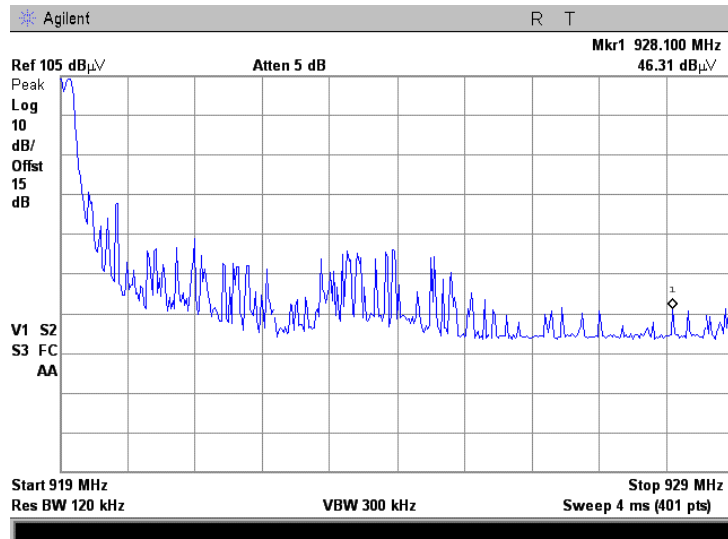

Test specification:		Section 15.247(d), Radiated spurious emissions	
Test procedure:		Public notice DA 00-705/ 47 CFR, Section 15.247(c) / ANSI C63.4, Section 13.1.4	
Test mode:	Compliance	Verdict:	PASS
Date:	12/29/2010		
Temperature: 22.2 °C	Air Pressure: 1013 hPa	Relative Humidity: 45 %	Power Supply: 120 VAC
Remarks:			

7.7 Field strength of spurious emissions

7.7.1 General

This test was performed to measure field strength of spurious emissions from the EUT. Specification test limits are given in Table 7.7.1.

Table 7.7.1 Radiated spurious emissions limits

Frequency, MHz	Field strength at 3 m within restricted bands, dB(μV/m) ^{***}			Attenuation of field strength of spurious versus carrier outside restricted bands, dBc ^{***}
	Peak	Quasi Peak	Average	
0.009 – 0.090	148.5 – 128.5	NA	128.5 – 108.5 ^{**}	20.0
0.090 – 0.110	NA	108.5 – 106.8 ^{**}	NA	
0.110 – 0.490	126.8 – 113.8	NA	106.8 – 93.8 ^{**}	
0.490 – 1.705	NA	73.8 – 63.0 ^{**}	NA	
1.705 – 30.0*		69.5		
30 – 88		40.0		
88 – 216		43.5		
216 – 960		46.0		
960 – 1000		54.0		
1000 – 10 th harmonic	74.0	NA	54.0	

*- The limit for 3 m test distance was calculated using the inverse square distance extrapolation factor as follows:

$$\text{Lim}_{S_2} = \text{Lim}_{S_1} + 40 \log(S_1/S_2),$$

where S_1 and S_2 – standard defined and test distance respectively in meters.

** - The limit decreases linearly with the logarithm of frequency.

*** - The field strength limits applied from the lowest radio frequency generated in the device, without going below 9 kHz up to the tenth harmonic of the highest fundamental frequency.

7.7.2 Test procedure for spurious emission field strength measurements in 9 kHz to 30 MHz band

7.7.2.1 The EUT was set up as shown in Figure 7.7.1, energized and the performance check was conducted.

7.7.2.2 The specified frequency range was investigated with antenna connected to spectrum analyzer/ EMI receiver. To find maximum radiation the turntable was rotated 360° and the measuring antenna was rotated around its vertical axis.

7.7.2.3 The worst test results (the lowest margins) were recorded and shown in the associated plots.

7.7.3 Test procedure for spurious emission field strength measurements above 30 MHz

7.7.3.1 The EUT was set up as shown in Figure 7.7.2, energized and the performance check was conducted.

7.7.3.2 The specified frequency range was investigated with antenna connected to spectrum analyzer/ EMI receiver. To find maximum radiation the turntable was rotated 360°, the measuring antenna height was changed from 1 to 4 m, its polarization was switched from vertical to horizontal.

7.7.3.3 The worst test results (the lowest margins) were recorded and shown in the associated plots.

Test specification: Section 15.247(d), Radiated spurious emissions			
Test procedure: Public notice DA 00-705/ 47 CFR, Section 15.247(c) / ANSI C63.4, Section 13.1.4			
Test mode: Compliance	Verdict: PASS		
Date: 12/29/2010			
Temperature: 22.2 °C	Air Pressure: 1013 hPa	Relative Humidity: 45 %	Power Supply: 120 VAC
Remarks:			

Figure 7.7.1 Setup for spurious emission field strength measurements below 30 MHz

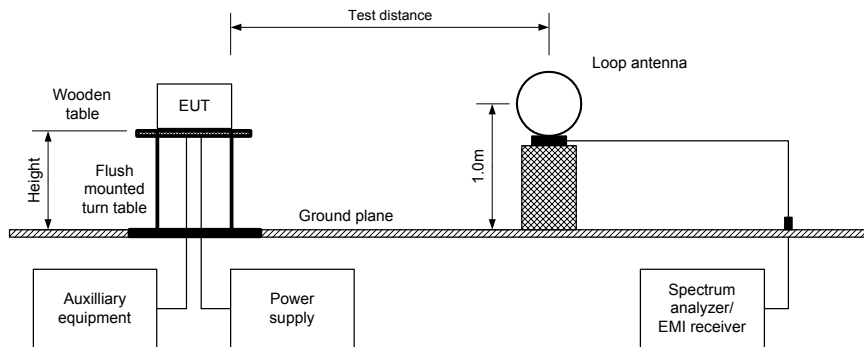
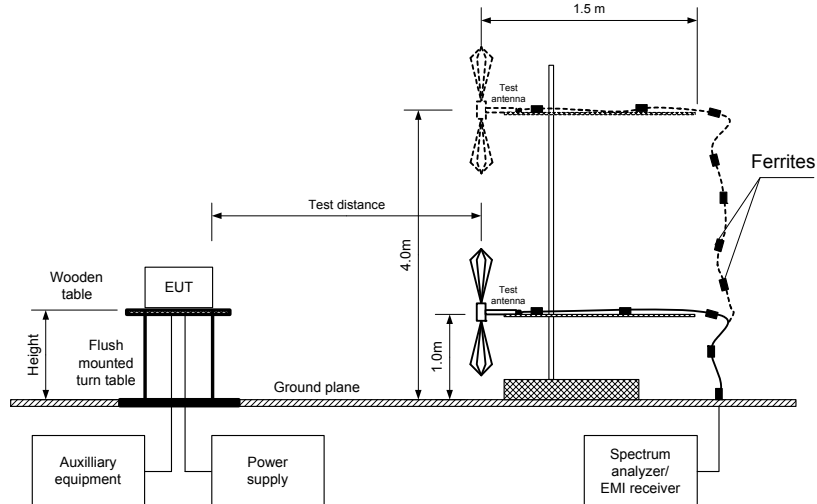

Figure 7.7.2 Setup for spurious emission field strength measurements above 30 MHz





Test specification:		Section 15.247(d), Radiated spurious emissions	
Test procedure:		Public notice DA 00-705/ 47 CFR, Section 15.247(c) / ANSI C63.4, Section 13.1.4	
Test mode:	Compliance	Verdict:	PASS
Date:	12/29/2010		
Temperature: 22.2 °C	Air Pressure: 1013 hPa	Relative Humidity: 45 %	Power Supply: 120 VAC
Remarks:			

Table 7.7.2 Field strength of emissions outside restricted bands

ASSIGNED FREQUENCY RANGE: 902-928 MHz
 INVESTIGATED FREQUENCY RANGE: 0.009 - 9500 MHz
 TEST DISTANCE: 3 m
 MODULATION: GFSK
 BIT RATE: 50 kbps
 DUTY CYCLE: 100 %
 TRANSMITTER OUTPUT POWER SETTINGS: Maximum
 DETECTOR USED: Peak
 RESOLUTION BANDWIDTH: 100 kHz
 VIDEO BANDWIDTH: 300 kHz
 TEST ANTENNA TYPE: Active loop (9 kHz – 30 MHz)
 Biconilog (30 MHz – 1000 MHz)
 Double ridged guide (above 1000 MHz)
 FREQUENCY HOPPING: Disabled

Frequency, MHz	Field strength of spurious, dB(µV/m)	Antenna polarization	Antenna height, m	Azimuth, degrees*	Field strength of carrier, dB(µV/m)	Attenuation below carrier, dBc	Limit, dBc	Margin, dB**	Verdict
Low carrier frequency									
1825.5000	46.01	V	1.3	80	104.70	58.69	20.0	38.69	Pass
1881.7713	57.86	V	1.3	10		46.84		26.84	
5476.3450	44.32	H	1.5	180		60.38		40.38	
5570.6018	52.46	V	1.5	0		52.24		32.24	
Mid carrier frequency									
1831.7020	48.18	V	1.6	110	101.91	53.73	20.0	33.73	Pass
1881.7950	58.24	V	1.2	20		43.67		23.67	
5495.3275	53.50	H	1.1	155		48.41		28.41	
High carrier frequency									
1838.2134	50.42	V	1.2	97	105.66	55.24	20.0	35.24	Pass
1881.7975	54.12	V	1.1	38		51.54		31.54	
5514.7975	49.81	V	1.7	168		55.85		35.85	

*- EUT front panel refers to 0 degrees position of turntable.
 **- Margin = Attenuation below carrier – specification limit.

Test specification: Section 15.247(d), Radiated spurious emissions	
Test procedure: Public notice DA 00-705/ 47 CFR, Section 15.247(c) / ANSI C63.4, Section 13.1.4	
Test mode: Compliance	Verdict: PASS
Date: 12/29/2010	
Temperature: 22.2 °C	Air Pressure: 1013 hPa
Relative Humidity: 45 %	
Power Supply: 120 VAC	
Remarks:	

Table 7.7.3 Field strength of spurious emissions above 1 GHz within restricted bands

ASSIGNED FREQUENCY RANGE: 902-928 MHz
 INVESTIGATED FREQUENCY RANGE: 1000 - 9500 MHz
 TEST DISTANCE: 3 m
 MODULATION: GFSK
 BIT RATE: 50 kbps
 DUTY CYCLE: 100 %
 TRANSMITTER OUTPUT POWER SETTINGS: Maximum
 DETECTOR USED: Peak
 RESOLUTION BANDWIDTH: 1000 kHz
 TEST ANTENNA TYPE: Double ridged guide
 FREQUENCY HOPPING: Disabled

Frequency, MHz	Antenna		Azimuth, degrees*	Peak field strength(VBW=3 MHz)			Average field strength(VBW=10 Hz)				Verdict
	Polarization	Height, m		Measured, dB(μV/m)	Limit, dB(μV/m)	Margin, dB**	Measured, dB(μV/m)	Calculated, dB(μV/m)	Limit, dB(μV/m)	Margin, dB***	
Low carrier frequency											
2737.2250	H	1.5	35	55.29	74.00	-18.71	50.74	23.54	54.00	-30.46	Pass
7302.0125	H	1.6	180	51.24	74.00	-22.76	45.19	17.99	54.00	-36.01	
9127.3625	H	1.4	95	52.21	74.00	-21.79	45.21	18.01	54.00	-35.99	
Mid carrier frequency											
2740.2900	H	1.5	210	54.35	74.00	-19.65	51.18	23.98	54.00	-30.02	Pass
7326.9207	H	1.7	90	53.59	74.00	-20.41	49.66	22.46	54.00	-31.54	
9158.6477	H	1.5	105	53.31	74.00	-20.69	48.81	21.61	54.00	-32.39	
High carrier frequency											
2757.3202	H	1.0	180	58.75	74.00	-15.25	50.99	23.79	54.00	-30.21	Pass
7352.8538	H	1.5	100	53.65	74.00	-20.35	49.10	21.90	54.00	-32.10	
9191.1600	H	1.5	90	56.61	74.00	-17.39	52.18	24.98	54.00	-29.02	

*- EUT front panel refers to 0 degrees position of turntable.
 **- Margin = Measured field strength - specification limit.
 ***- Margin = Calculated field strength - specification limit,
 where Calculated field strength = Measured field strength + average factor.

Table 7.7.4 Average factor calculation

Transmission pulse		Transmission burst		Transmission train duration, ms	Average factor, dB
Duration, ms	Period, ms	Duration, ms	Period, ms		
4.35	2000	NA	NA	NA	-27.2

*- Average factor was calculated as follows

for pulse train shorter than 100 ms:

$$Average\ factor = 20 \times \log_{10} \left(\frac{Pulse\ duration}{Pulse\ period} \times \frac{Burst\ duration}{Train\ duration} \times Number\ of\ bursts\ within\ pulse\ train \right)$$

for pulse train longer than 100 ms:

$$Average\ factor = 20 \times \log_{10} \left(\frac{Pulse\ duration}{Pulse\ period} \times \frac{Burst\ duration}{100ms} \times Number\ of\ bursts\ within\ 100ms \right)$$

Test specification: Section 15.247(d), Radiated spurious emissions	
Test procedure: Public notice DA 00-705/ 47 CFR, Section 15.247(c) / ANSI C63.4, Section 13.1.4	
Test mode: Compliance	Verdict: PASS
Date: 12/29/2010	
Temperature: 22.2 °C	Air Pressure: 1013 hPa
Relative Humidity: 45 %	
Power Supply: 120 VAC	
Remarks:	

Table 7.7.5 Field strength of spurious emissions below 1 GHz within restricted bands

ASSIGNED FREQUENCY RANGE: 902-928 MHz
 INVESTIGATED FREQUENCY RANGE: 0.009 – 1000 MHz
 TEST DISTANCE: 3 m
 MODULATION: GFSK
 BIT RATE: 50 kbps
 DUTY CYCLE: 100 %
 TRANSMITTER OUTPUT POWER SETTINGS: Maximum
 RESOLUTION BANDWIDTH: 0.2 kHz (9 kHz – 150 kHz)
 9.0 kHz (150 kHz – 30 MHz)
 120 kHz (30 MHz – 1000 MHz)
 VIDEO BANDWIDTH: > Resolution bandwidth
 TEST ANTENNA TYPE: Active loop (9 kHz – 30 MHz)
 Biconical (30 MHz – 200 MHz)
 Log periodic (200 MHz – 1000 MHz)
 Biconilog (30 MHz – 1000 MHz)
 Disabled

FREQUENCY HOPPING:

Frequency MHz	Peak emission, dB(µV/m)	Quasi-peak			Antenna polarization	Antenna height, m	Turn-table position**, degrees	Verdict
		Measured emission, dB(µV/m)	Limit, dB(µV/m)	Margin, dB*				
Low carrier frequency								
116.5	33.2	27.0	43.5	-16.5	V	1.0	80	Pass
Mid carrier frequency								
117.1	30.2	26.1	43.5	-17.4	V	1.0	80	Pass
High carrier frequency								
118.1	31.5	27.8	43.5	-15.7	V	1.0	80	Pass

*- Margin = Measured emission - specification limit.

**- EUT front panel refer to 0 degrees position of turntable.

Table 7.7.6 Restricted bands

MHz	MHz	MHz	MHz	MHz	GHz
0.09 - 0.11	8.37625 - 8.38675	73 - 74.6	399.9 - 410	2690 - 2900	10.6 - 12.7
0.495 - 0.505	8.41425 - 8.41475	74.8 - 75.2	608 - 614	3260 - 3267	13.25 - 13.4
2.1735 - 2.1905	12.29 - 12.293	108 - 121.94	960 - 1240	3332 - 3339	14.47 - 14.5
4.125 - 4.128	12.51975 - 12.52025	123 - 138	1300 - 1427	3345.8 - 3358	15.35 - 16.2
4.17725 - 4.17775	12.57675 - 12.57725	149.9 - 150.05	1435 - 1626.5	3600 - 4400	17.7 - 21.4
4.20725 - 4.20775	13.36 - 13.41	156.52475 - 156.52525	1645.5 - 1646.5	4500 - 5150	22.01 - 23.12
6.215 - 6.218	16.42 - 16.423	156.7 - 156.9	1660 - 1710	5350 - 5460	23.6 - 24
6.26775 - 6.26825	16.69475 - 16.69525	162.0125 - 167.17	1718.8 - 1722.2	7250 - 7750	31.2 - 31.8
6.31175 - 6.31225	16.80425 - 16.80475	167.72 - 173.2	2200 - 2300	8025 - 8500	36.43 - 36.5
8.291 - 8.294	25.5 - 25.67	240 - 285	2310 - 2390	9000 - 9200	Above 38.6
8.362 - 8.366	37.5 - 38.25	322 - 335.4	2483.5 - 2500	9300 - 9500	

Reference numbers of test equipment used

HL 0446	HL 0521	HL 0604	HL 1984	HL 2780	HL 2870	HL 2871	HL 3119
HL 3334	HL 3342	HL 3343	HL 3622	HL 3883			

Full description is given in Appendix A.

Test specification: Section 15.247(d), Radiated spurious emissions			
Test procedure: Public notice DA 00-705/ 47 CFR, Section 15.247(c) / ANSI C63.4, Section 13.1.4			
Test mode: Compliance	Verdict: PASS		
Date: 12/29/2010			
Temperature: 22.2 °C	Air Pressure: 1013 hPa	Relative Humidity: 45 %	Power Supply: 120 VAC
Remarks:			

Plot 7.7.1 Radiated emission measurements at the low carrier frequency

TEST SITE: Semi anechoic chamber
TEST DISTANCE: 3 m
ANTENNA POLARIZATION: Vertical & Horizontal

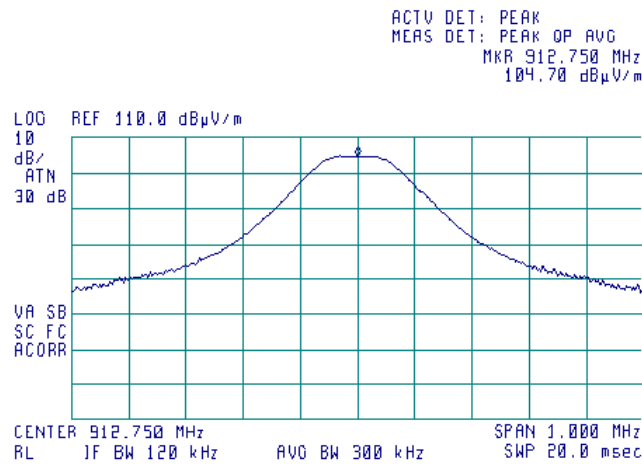

Plot 7.7.2 Radiated emission measurements at the mid carrier frequency

TEST SITE: Semi anechoic chamber
TEST DISTANCE: 3 m
ANTENNA POLARIZATION: Vertical & Horizontal

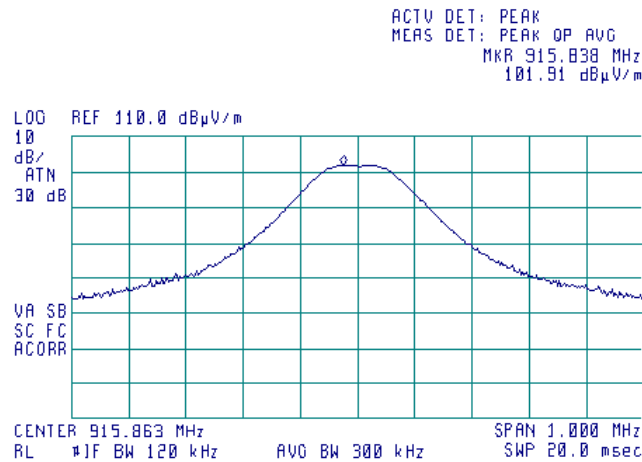

Test specification: Section 15.247(d), Radiated spurious emissions			
Test procedure: Public notice DA 00-705/ 47 CFR, Section 15.247(c) / ANSI C63.4, Section 13.1.4			
Test mode: Compliance	Verdict: PASS		
Date: 12/29/2010			
Temperature: 22.2 °C	Air Pressure: 1013 hPa	Relative Humidity: 45 %	Power Supply: 120 VAC
Remarks:			

Plot 7.7.3 Radiated emission measurements at the high carrier frequency

TEST SITE: Semi anechoic chamber
TEST DISTANCE: 3 m
ANTENNA POLARIZATION: Vertical & Horizontal

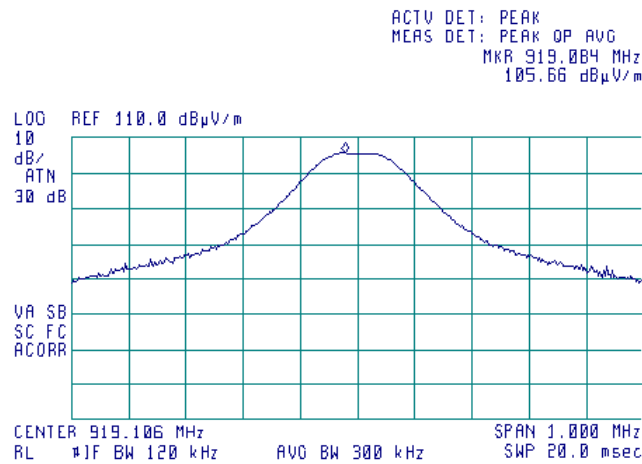

Plot 7.7.4 Radiated emission measurements from 9 to 150 kHz at the low, mid, high carrier frequency

TEST SITE: Semi anechoic chamber
TEST DISTANCE: 3 m
ANTENNA POLARIZATION: Vertical

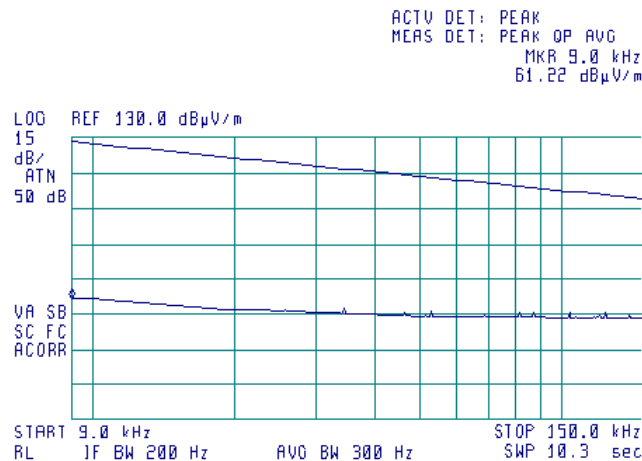



HERMON LABORATORIES

Test specification: Section 15.247(d), Radiated spurious emissions			
Test procedure: Public notice DA 00-705/ 47 CFR, Section 15.247(c) / ANSI C63.4, Section 13.1.4			
Test mode: Compliance	Verdict: PASS		
Date: 12/29/2010			
Temperature: 22.2 °C	Air Pressure: 1013 hPa	Relative Humidity: 45 %	Power Supply: 120 VAC
Remarks:			

Plot 7.7.5 Radiated emission measurements from 0.15 to 30 MHz at the low, mid, high carrier frequency

TEST SITE: Semi anechoic chamber
TEST DISTANCE: 3 m
ANTENNA POLARIZATION: Vertical



ACTV DET: PEAK
MEAS DET: PEAK OP AVG
MKR 150 kHz
56.97 dBµV/m

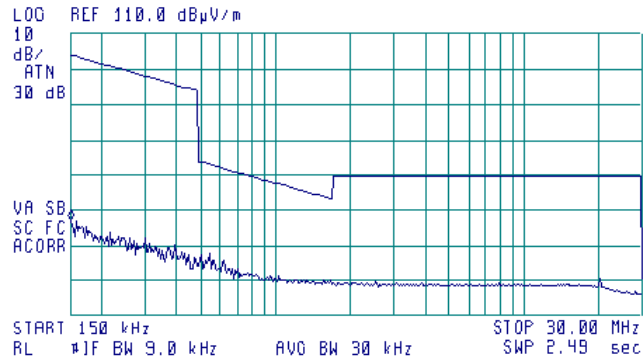

Test specification: Section 15.247(d), Radiated spurious emissions			
Test procedure: Public notice DA 00-705/ 47 CFR, Section 15.247(c) / ANSI C63.4, Section 13.1.4			
Test mode: Compliance	Verdict: PASS		
Date: 12/29/2010			
Temperature: 22.2 °C	Air Pressure: 1013 hPa	Relative Humidity: 45 %	Power Supply: 120 VAC
Remarks:			

Plot 7.7.6 Radiated emission measurements from 30 to 902 MHz at the low carrier frequency

TEST SITE: Semi anechoic chamber
TEST DISTANCE: 3 m
ANTENNA POLARIZATION: Vertical and Horizontal

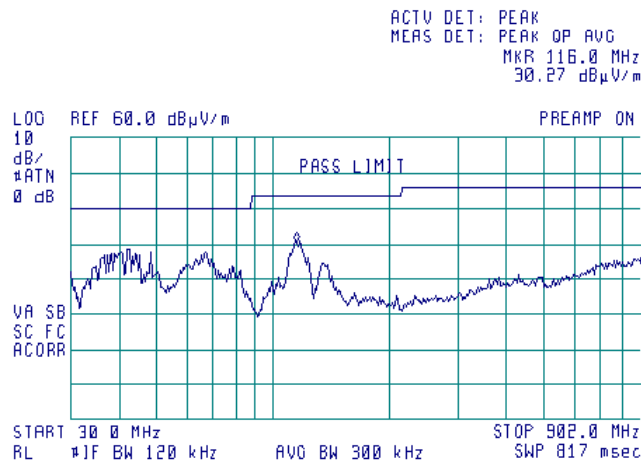

Plot 7.7.7 Radiated emission measurements from 928 to 1000 MHz at the low carrier frequency

TEST SITE: Semi anechoic chamber
TEST DISTANCE: 3 m
ANTENNA POLARIZATION: Vertical and Horizontal

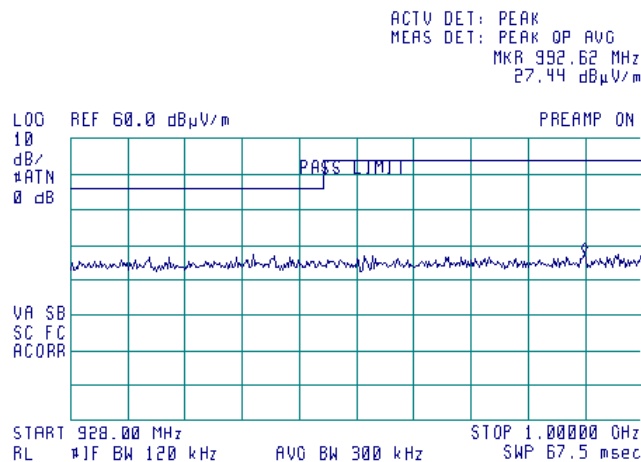

Test specification: Section 15.247(d), Radiated spurious emissions			
Test procedure: Public notice DA 00-705/ 47 CFR, Section 15.247(c) / ANSI C63.4, Section 13.1.4			
Test mode: Compliance	Verdict: PASS		
Date: 12/29/2010			
Temperature: 22.2 °C	Air Pressure: 1013 hPa	Relative Humidity: 45 %	Power Supply: 120 VAC
Remarks:			

Plot 7.7.8 Radiated emission measurements from 30 to 902 MHz at the mid carrier frequency

TEST SITE: Semi anechoic chamber
TEST DISTANCE: 3 m
ANTENNA POLARIZATION: Vertical and Horizontal

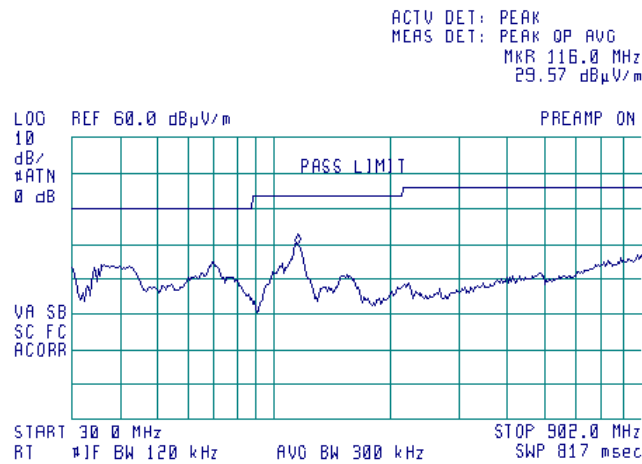

Plot 7.7.9 Radiated emission measurements from 928 to 1000 MHz at the mid carrier frequency

TEST SITE: Semi anechoic chamber
TEST DISTANCE: 3 m
ANTENNA POLARIZATION: Vertical and Horizontal

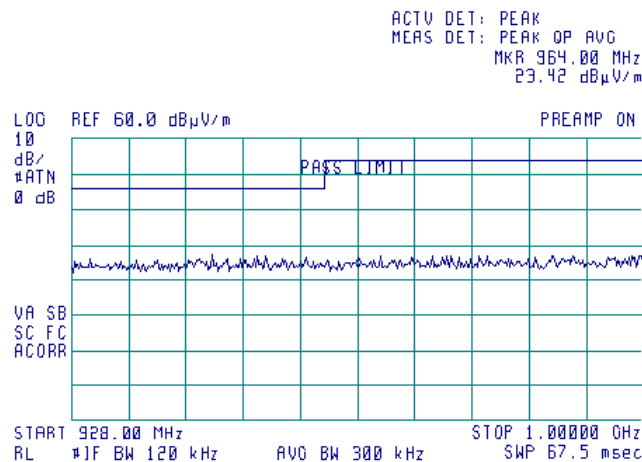

Test specification: Section 15.247(d), Radiated spurious emissions			
Test procedure: Public notice DA 00-705/ 47 CFR, Section 15.247(c) / ANSI C63.4, Section 13.1.4			
Test mode: Compliance	Verdict: PASS		
Date: 12/29/2010			
Temperature: 22.2 °C	Air Pressure: 1013 hPa	Relative Humidity: 45 %	Power Supply: 120 VAC
Remarks:			

Plot 7.7.10 Radiated emission measurements from 30 to 902 MHz at the high carrier frequency

TEST SITE: Semi anechoic chamber
TEST DISTANCE: 3 m
ANTENNA POLARIZATION: Vertical and Horizontal

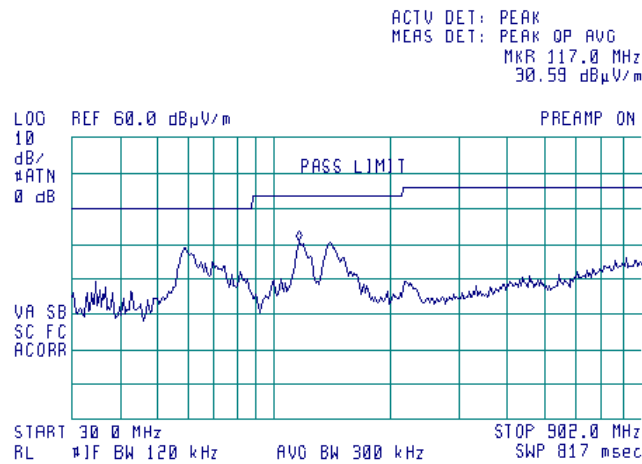

Plot 7.7.11 Radiated emission measurements from 928 to 1000 MHz at the high carrier frequency

TEST SITE: Semi anechoic chamber
TEST DISTANCE: 3 m
ANTENNA POLARIZATION: Vertical and Horizontal

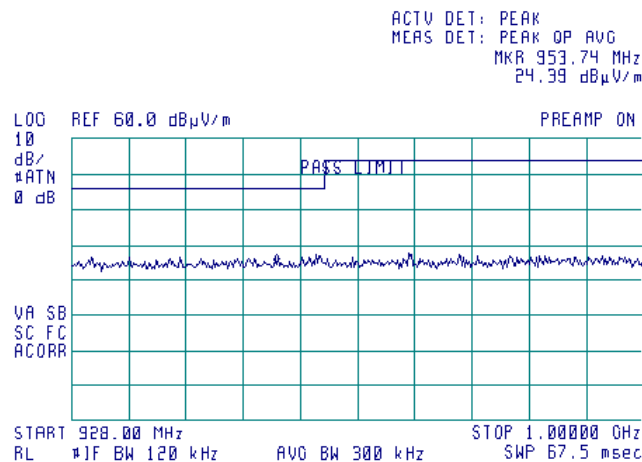

Test specification: Section 15.247(d), Radiated spurious emissions			
Test procedure: Public notice DA 00-705/ 47 CFR, Section 15.247(c) / ANSI C63.4, Section 13.1.4			
Test mode: Compliance	Verdict: PASS		
Date: 12/29/2010			
Temperature: 22.2 °C	Air Pressure: 1013 hPa	Relative Humidity: 45 %	Power Supply: 120 VAC
Remarks:			

Plot 7.7.12 Radiated emission measurements from 1000 to 5000 MHz at the low carrier frequency

TEST SITE: Semi anechoic chamber
TEST DISTANCE: 3 m
ANTENNA POLARIZATION: Vertical and Horizontal

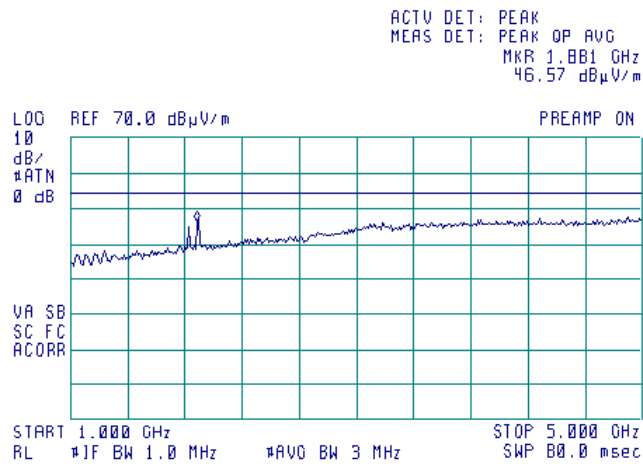

Plot 7.7.13 Radiated emission measurements from 1000 to 5000 MHz at the mid carrier frequency

TEST SITE: Semi anechoic chamber
TEST DISTANCE: 3 m
ANTENNA POLARIZATION: Vertical and Horizontal

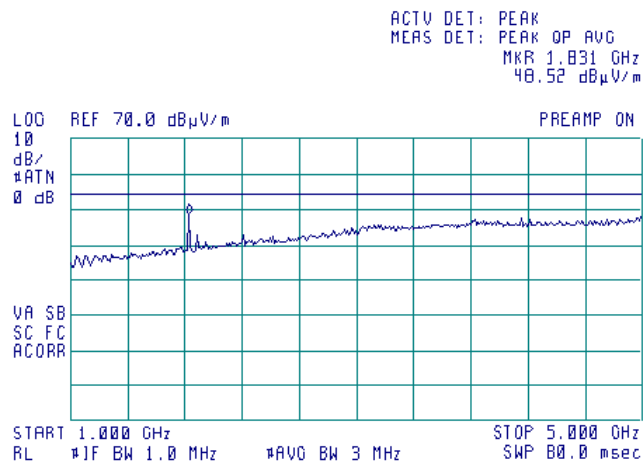

Test specification: Section 15.247(d), Radiated spurious emissions			
Test procedure: Public notice DA 00-705/ 47 CFR, Section 15.247(c) / ANSI C63.4, Section 13.1.4			
Test mode: Compliance	Verdict: PASS		
Date: 12/29/2010			
Temperature: 22.2 °C	Air Pressure: 1013 hPa	Relative Humidity: 45 %	Power Supply: 120 VAC
Remarks:			

Plot 7.7.14 Radiated emission measurements from 1000 to 5000 MHz at the high carrier frequency

TEST SITE: Semi anechoic chamber
TEST DISTANCE: 3 m
ANTENNA POLARIZATION: Vertical and Horizontal

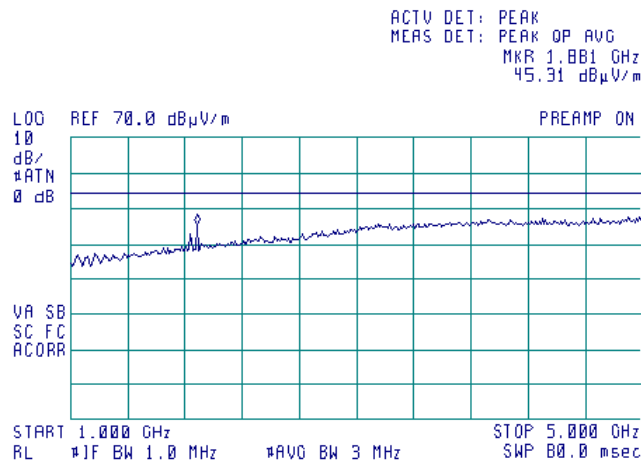

Plot 7.7.15 Radiated emission measurements from 5000 to 9500 MHz at the low carrier frequency

TEST SITE: Semi anechoic chamber
TEST DISTANCE: 3 m
ANTENNA POLARIZATION: Vertical and Horizontal

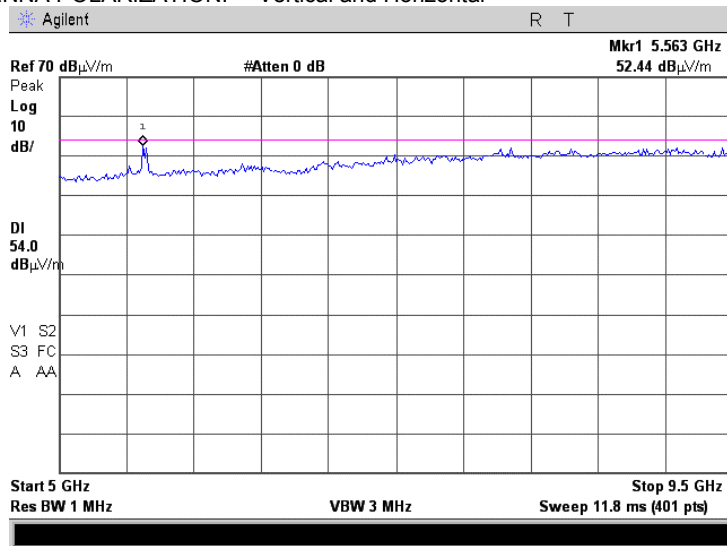

Test specification: Section 15.247(d), Radiated spurious emissions			
Test procedure: Public notice DA 00-705/ 47 CFR, Section 15.247(c) / ANSI C63.4, Section 13.1.4			
Test mode: Compliance	Verdict: PASS		
Date: 12/29/2010			
Temperature: 22.2 °C	Air Pressure: 1013 hPa	Relative Humidity: 45 %	Power Supply: 120 VAC
Remarks:			

Plot 7.7.16 Radiated emission measurements from 5000 to 9500 MHz at the mid carrier frequency

TEST SITE: Semi anechoic chamber
TEST DISTANCE: 3 m
ANTENNA POLARIZATION: Vertical and Horizontal

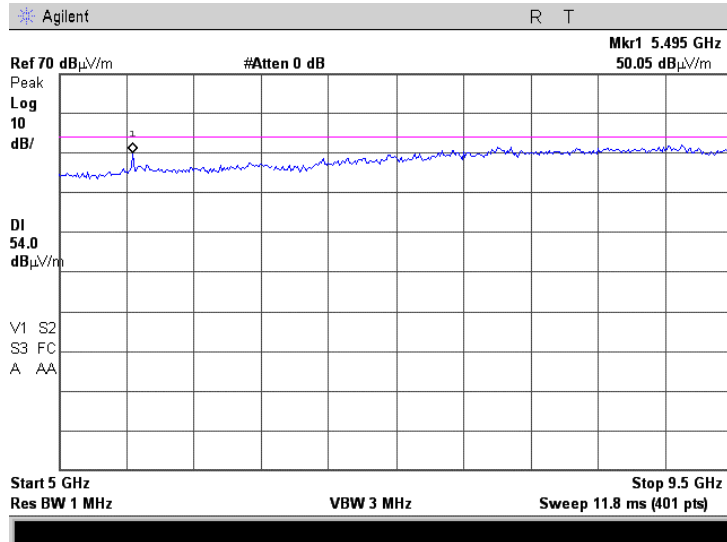

Plot 7.7.17 Radiated emission measurements from 5000 to 9500 MHz at the high carrier frequency

TEST SITE: Semi anechoic chamber
TEST DISTANCE: 3 m
ANTENNA POLARIZATION: Vertical and Horizontal

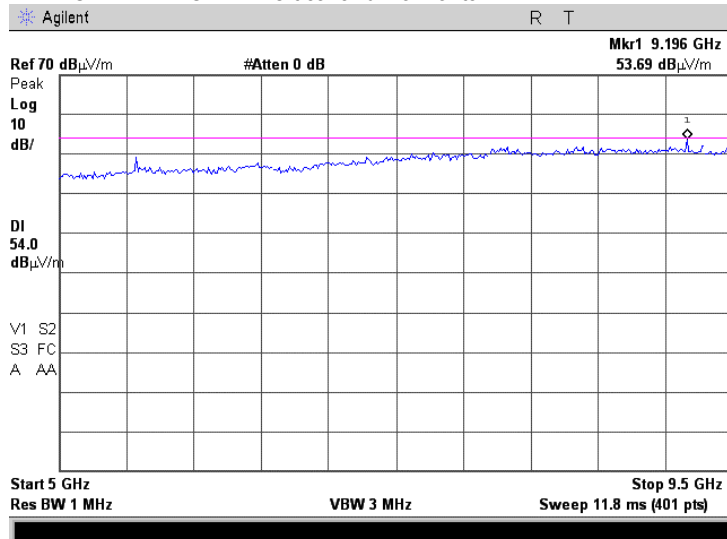

Test specification:		Section 15.247(d), Radiated spurious emissions	
Test procedure:		Public notice DA 00-705/ 47 CFR, Section 15.247(c) / ANSI C63.4, Section 13.1.4	
Test mode:	Compliance	Verdict:	PASS
Date:	12/29/2010		
Temperature: 22.2 °C	Air Pressure: 1013 hPa	Relative Humidity: 45 %	Power Supply: 120 VAC
Remarks:			

Plot 7.7.18 Radiated emission measurements at the second harmonic of low carrier frequency

TEST SITE: Semi anechoic chamber
TEST DISTANCE: 3 m

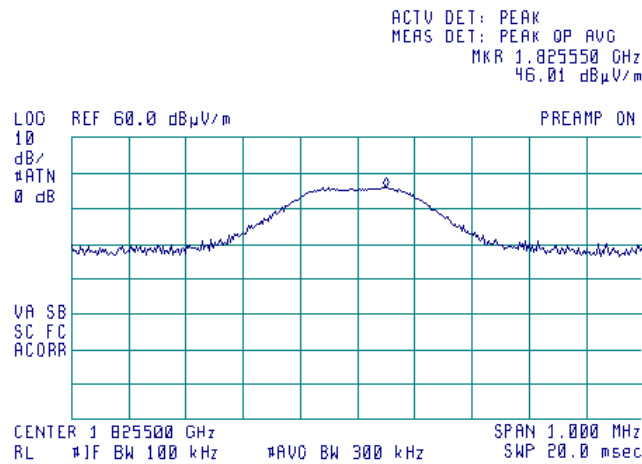

Plot 7.7.19 Radiated emission measurements at the second harmonic of mid carrier frequency

TEST SITE: Semi anechoic chamber
TEST DISTANCE: 3 m

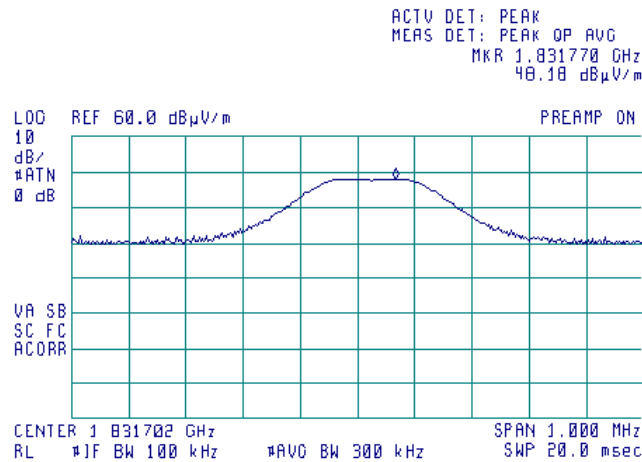

Test specification: Section 15.247(d), Radiated spurious emissions			
Test procedure: Public notice DA 00-705/ 47 CFR, Section 15.247(c) / ANSI C63.4, Section 13.1.4			
Test mode: Compliance	Verdict: PASS		
Date: 12/29/2010			
Temperature: 22.2 °C	Air Pressure: 1013 hPa	Relative Humidity: 45 %	Power Supply: 120 VAC
Remarks:			

Plot 7.7.20 Radiated emission measurements at the second harmonic of high carrier frequency

TEST SITE: OATS
TEST DISTANCE: 3 m

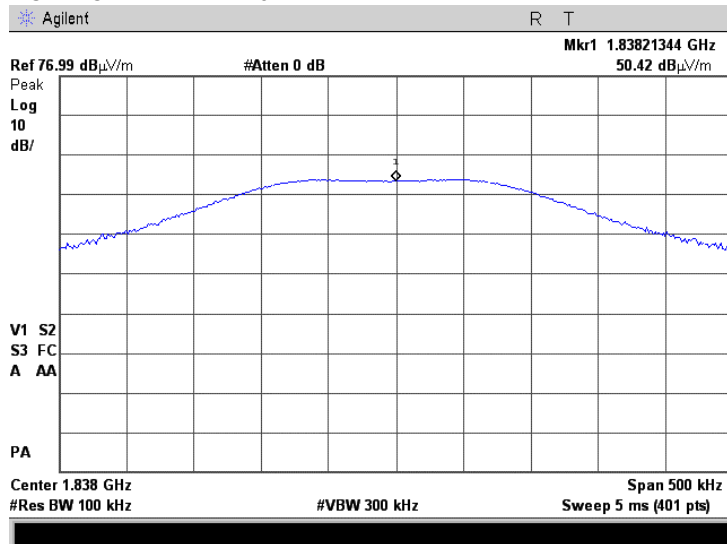

Test specification: Section 15.247(d), Radiated spurious emissions			
Test procedure: Public notice DA 00-705/ 47 CFR, Section 15.247(c) / ANSI C63.4, Section 13.1.4			
Test mode: Compliance	Verdict: PASS		
Date: 12/29/2010			
Temperature: 22.2 °C	Air Pressure: 1013 hPa	Relative Humidity: 45 %	Power Supply: 120 VAC
Remarks:			

Plot 7.7.21 Radiated emission measurements at the third harmonic of low carrier frequency

TEST SITE: OATS
TEST DISTANCE: 3 m

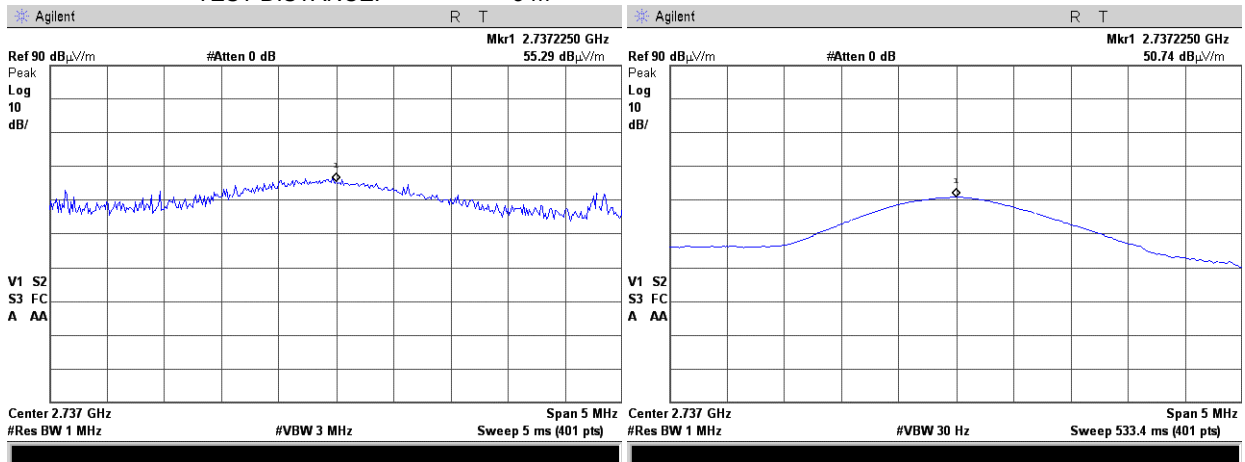

Plot 7.7.22 Radiated emission measurements at the third harmonic of mid carrier frequency

TEST SITE: OATS
TEST DISTANCE: 3 m

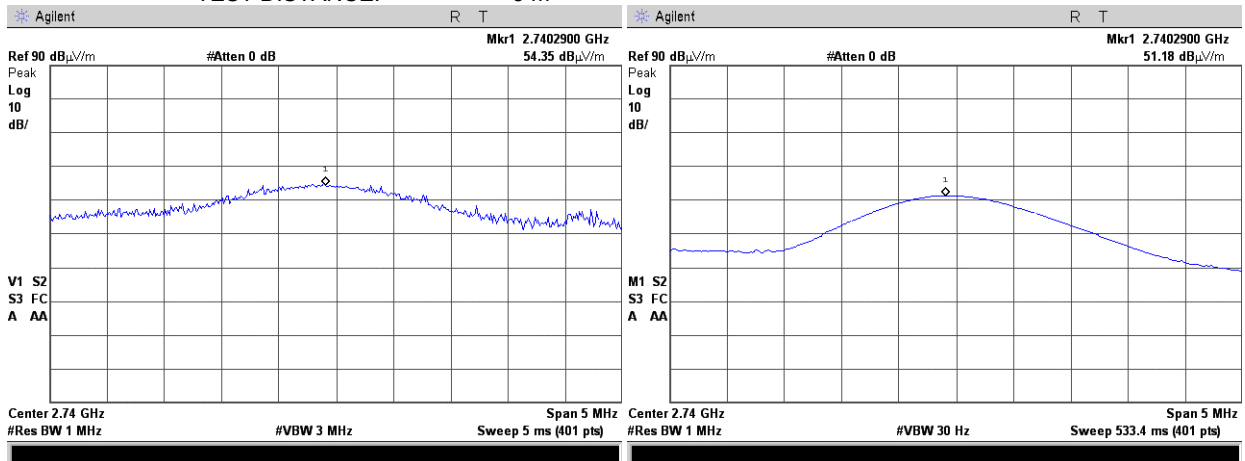

Test specification:		Section 15.247(d), Radiated spurious emissions	
Test procedure:		Public notice DA 00-705/ 47 CFR, Section 15.247(c) / ANSI C63.4, Section 13.1.4	
Test mode:		Verdict: PASS	
Date:			
Temperature: 22.2 °C		Air Pressure: 1013 hPa	
Remarks:		Relative Humidity: 45 %	
		Power Supply: 120 VAC	

Plot 7.7.23 Radiated emission measurements at the third harmonic of high carrier frequency

TEST SITE: OATS
TEST DISTANCE: 3 m

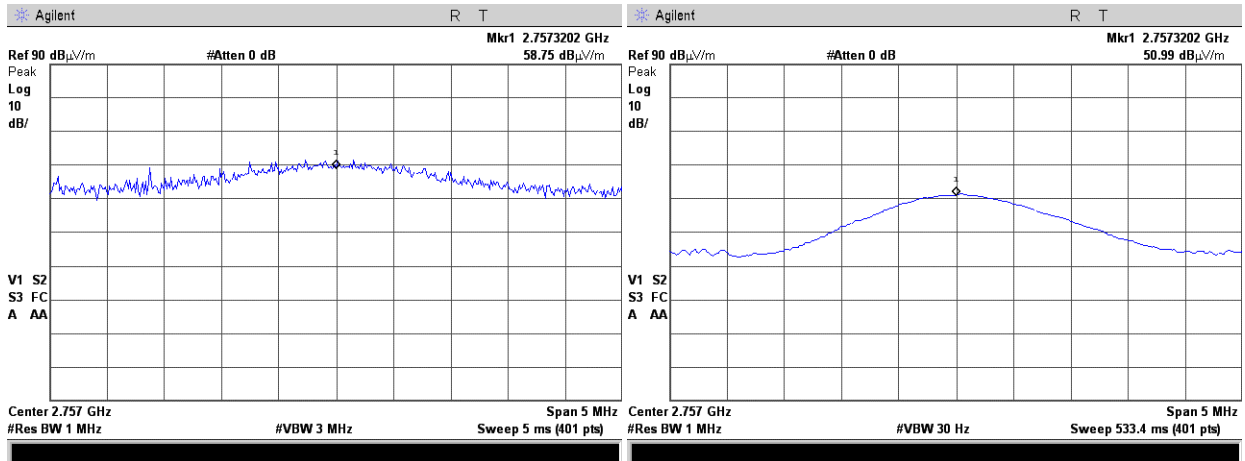

Test specification: Section 15.247(d), Radiated spurious emissions			
Test procedure: Public notice DA 00-705/ 47 CFR, Section 15.247(c) / ANSI C63.4, Section 13.1.4			
Test mode: Compliance	Verdict: PASS		
Date: 12/29/2010			
Temperature: 22.2 °C	Air Pressure: 1013 hPa	Relative Humidity: 45 %	Power Supply: 120 VAC
Remarks:			

Plot 7.7.24 Radiated emission measurements at the sixth harmonic of low carrier frequency

TEST SITE: OATS
TEST DISTANCE: 3 m

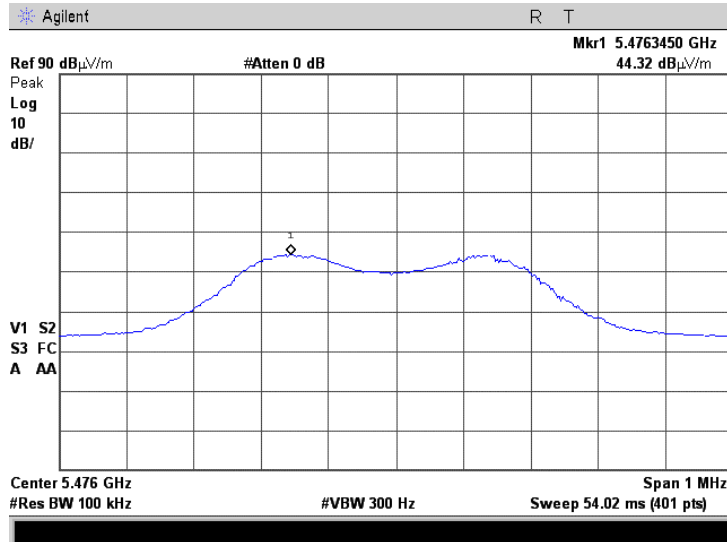

Plot 7.7.25 Radiated emission measurements at the sixth harmonic of mid carrier frequency

TEST SITE: OATS
TEST DISTANCE: 3 m

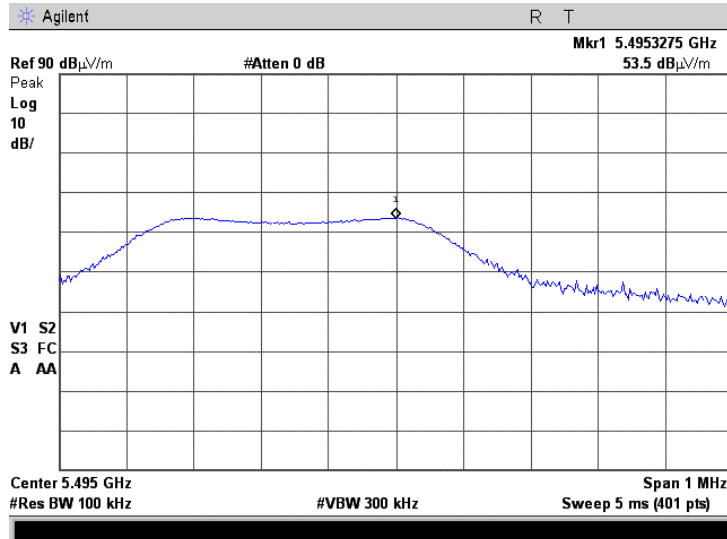

Test specification:		Section 15.247(d), Radiated spurious emissions	
Test procedure:		Public notice DA 00-705/ 47 CFR, Section 15.247(c) / ANSI C63.4, Section 13.1.4	
Test mode:	Compliance	Verdict:	PASS
Date:	12/29/2010		
Temperature: 22.2 °C	Air Pressure: 1013 hPa	Relative Humidity: 45 %	Power Supply: 120 VAC
Remarks:			

Plot 7.7.26 Radiated emission measurements at the sixth harmonic of high carrier frequency

TEST SITE: OATS
TEST DISTANCE: 3 m

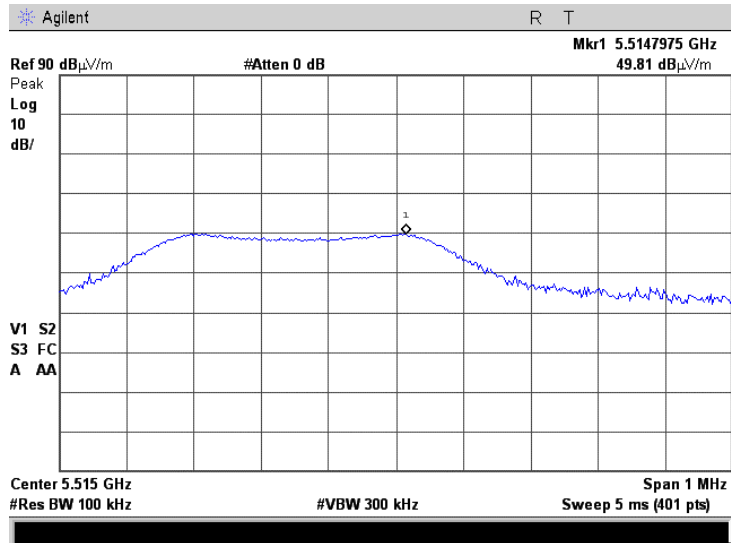

Test specification: Section 15.247(d), Radiated spurious emissions			
Test procedure: Public notice DA 00-705/ 47 CFR, Section 15.247(c) / ANSI C63.4, Section 13.1.4			
Test mode: Compliance	Verdict: PASS		
Date: 12/29/2010			
Temperature: 22.2 °C	Air Pressure: 1013 hPa	Relative Humidity: 45 %	Power Supply: 120 VAC
Remarks:			

Plot 7.7.27 Radiated emission measurements at the eighth harmonic of low carrier frequency

TEST SITE: OATS
TEST DISTANCE: 3 m

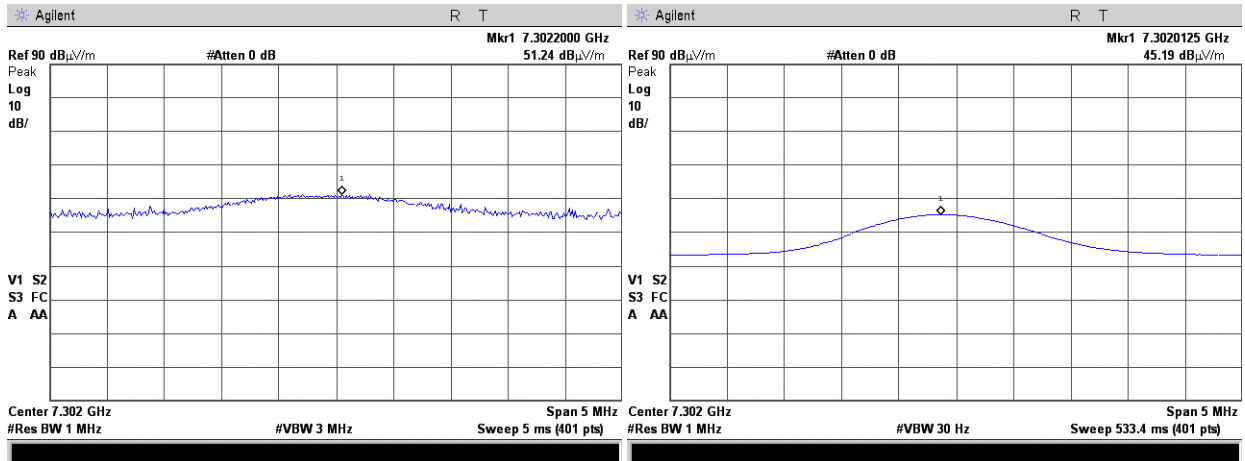

Plot 7.7.28 Radiated emission measurements at the eighth harmonic of mid carrier frequency

TEST SITE: OATS
TEST DISTANCE: 3 m

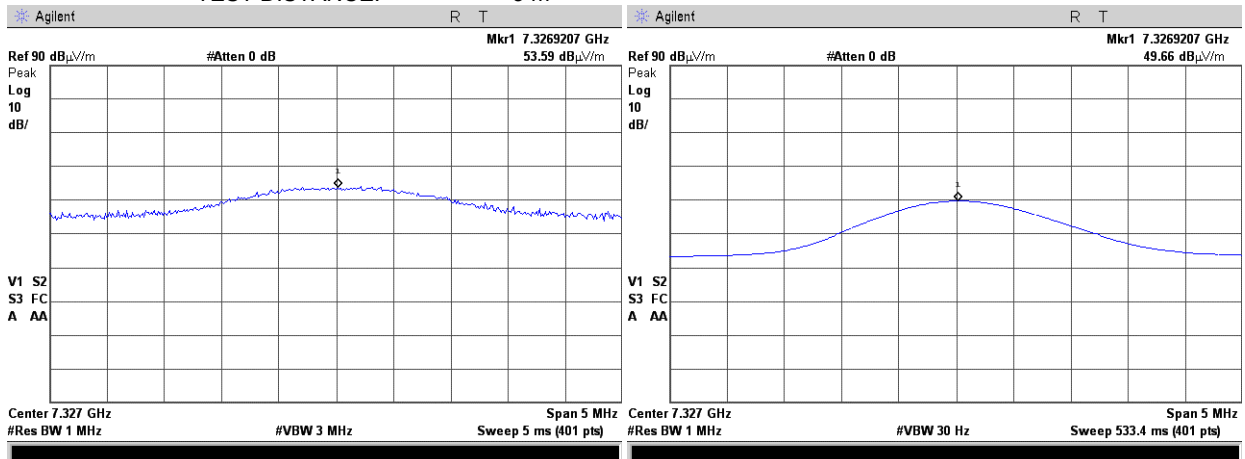

Test specification: Section 15.247(d), Radiated spurious emissions			
Test procedure: Public notice DA 00-705/ 47 CFR, Section 15.247(c) / ANSI C63.4, Section 13.1.4			
Test mode: Compliance	Verdict: PASS		
Date: 12/29/2010			
Temperature: 22.2 °C	Air Pressure: 1013 hPa	Relative Humidity: 45 %	Power Supply: 120 VAC
Remarks:			

Plot 7.7.29 Radiated emission measurements at the eighth harmonic of high carrier frequency

TEST SITE: OATS
TEST DISTANCE: 3 m

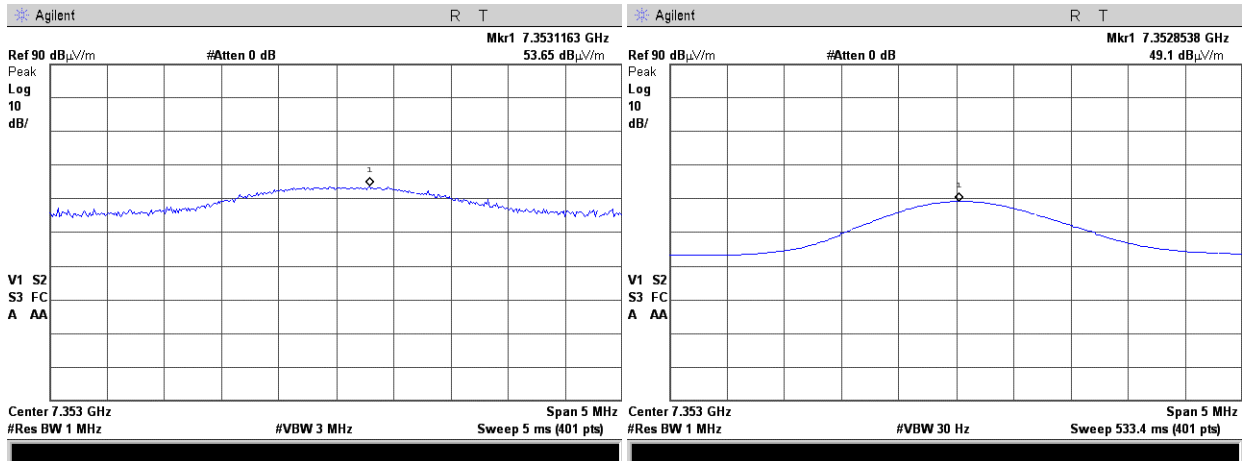

Test specification: Section 15.247(d), Radiated spurious emissions			
Test procedure: Public notice DA 00-705/ 47 CFR, Section 15.247(c) / ANSI C63.4, Section 13.1.4			
Test mode: Compliance	Verdict: PASS		
Date: 12/29/2010			
Temperature: 22.2 °C	Air Pressure: 1013 hPa	Relative Humidity: 45 %	Power Supply: 120 VAC
Remarks:			

Plot 7.7.30 Radiated emission measurements at the tenth harmonic of low carrier frequency

TEST SITE: OATS
TEST DISTANCE: 3 m

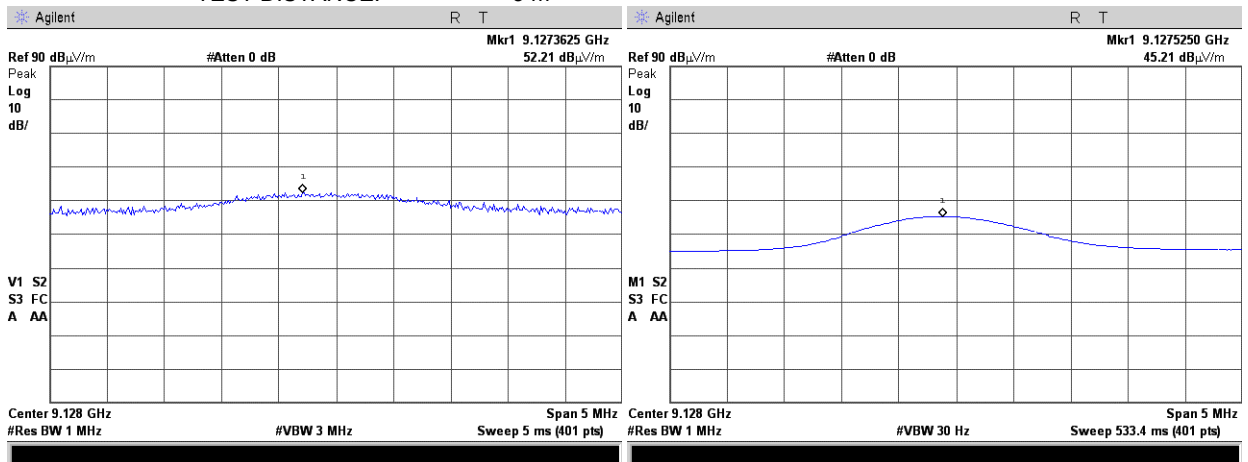

Plot 7.7.31 Radiated emission measurements at the tenth harmonic of mid carrier frequency

TEST SITE: OATS
TEST DISTANCE: 3 m

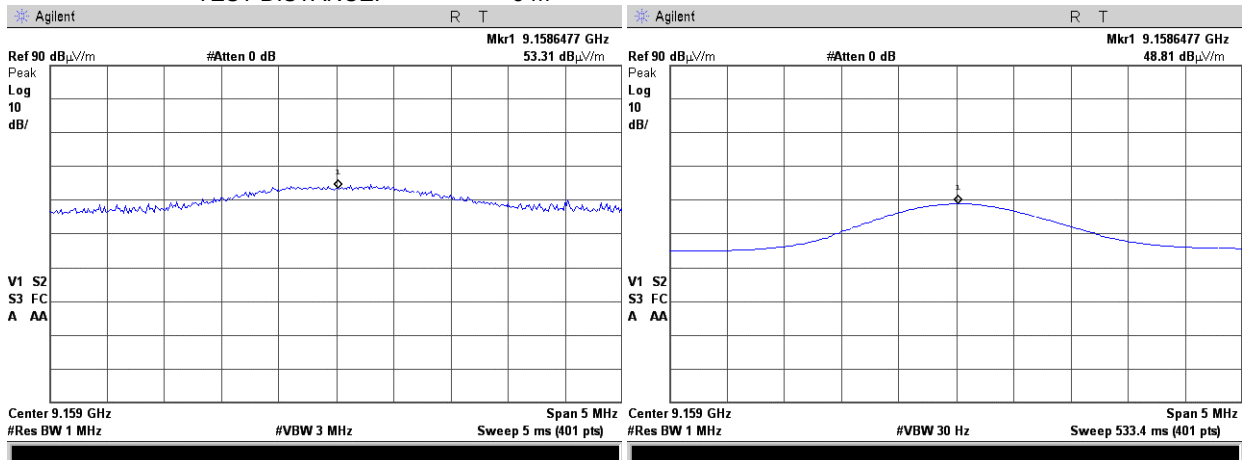

Test specification:		Section 15.247(d), Radiated spurious emissions	
Test procedure:		Public notice DA 00-705/ 47 CFR, Section 15.247(c) / ANSI C63.4, Section 13.1.4	
Test mode:	Compliance	Verdict:	PASS
Date:	12/29/2010		
Temperature: 22.2 °C	Air Pressure: 1013 hPa	Relative Humidity: 45 %	Power Supply: 120 VAC
Remarks:			

Plot 7.7.32 Radiated emission measurements at the tenth harmonic of high carrier frequency

TEST SITE: OATS
TEST DISTANCE: 3 m

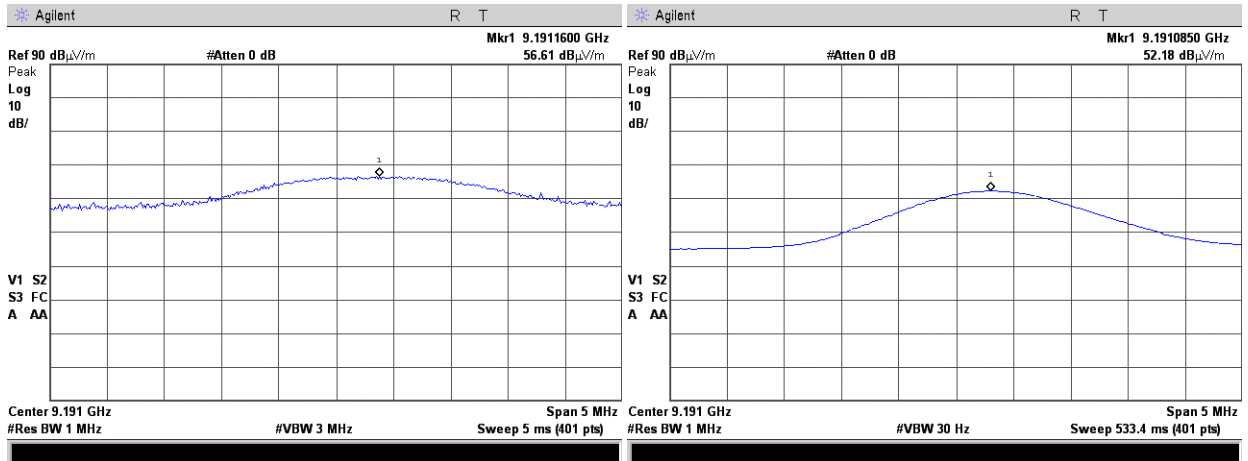

Test specification:		Section 15.247(d), Radiated spurious emissions	
Test procedure:		Public notice DA 00-705/ 47 CFR, Section 15.247(c) / ANSI C63.4, Section 13.1.4	
Test mode:		Compliance	
Date:		12/29/2010	
Temperature: 22.2 °C		Air Pressure: 1013 hPa	
Remarks:		Relative Humidity: 45 %	
		Power Supply: 120 VAC	
		Verdict: PASS	

Plot 7.7.33 Transmission pulse duration

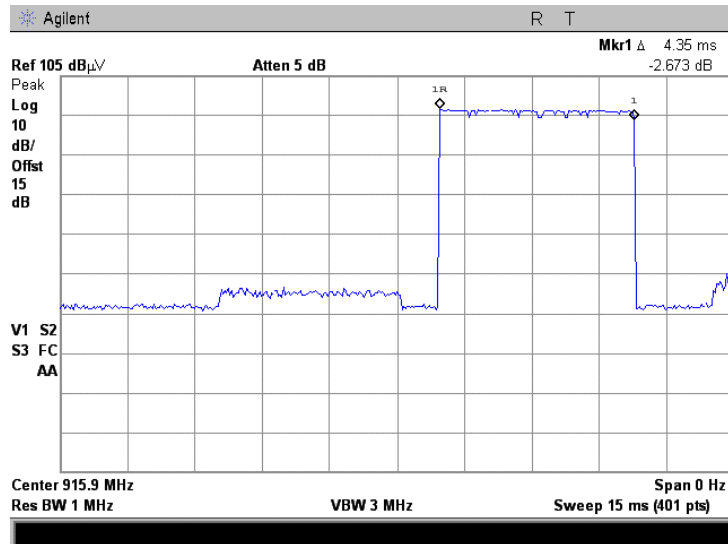

Plot 7.7.34 Transmission pulse period

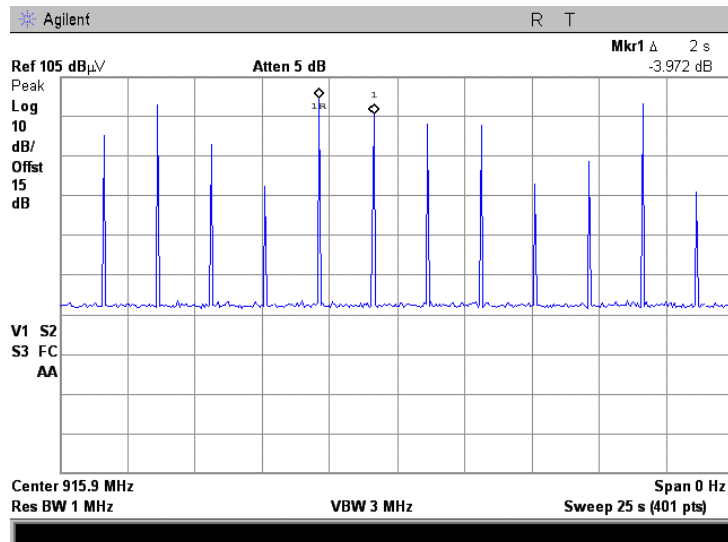

Test specification: Section 15.207(a), Conducted emission			
Test procedure: ANSI C63.4, Section 13.1.3			
Test mode: Compliance	Verdict: PASS		
Date: 12/28/2010			
Temperature: 23.6 °C	Air Pressure: 1015 hPa	Relative Humidity: 32 %	Power Supply: 120 VAC
Remarks:			

7.8 Conducted emissions

7.8.1 General

This test was performed to measure common mode conducted emissions at the power port. Specification test limits are given in Table 7.8.1.

Table 7.8.1 Limits for conducted emissions

Frequency, MHz	Class B limit, dB(μ V)	
	QP	AVRG
0.15 - 0.5	66 - 56*	56 - 46*
0.5 - 5.0	56	46
5.0 - 30	60	50

* The limit decreases linearly with the logarithm of frequency.

7.8.2 Test procedure

7.8.2.1 The EUT was set up as shown in Figure 7.8.1, energized and the performance check was conducted.

7.8.2.2 The measurements were performed at power terminals with the LISN, connected to a spectrum analyzer in the frequency range referred to in Table 7.8.2. Unused coaxial connector of the LISN was terminated with 50 Ohm. Quasi-peak and average detectors were used throughout the testing.

7.8.2.3 The position of the device cables was varied to determine maximum emission level.

7.8.2.4 The worst test results (the lowest margins) were recorded in Table 7.8.2 and shown in the associated plots.

Figure 7.8.1 Setup for conducted emission measurements, table-top equipment

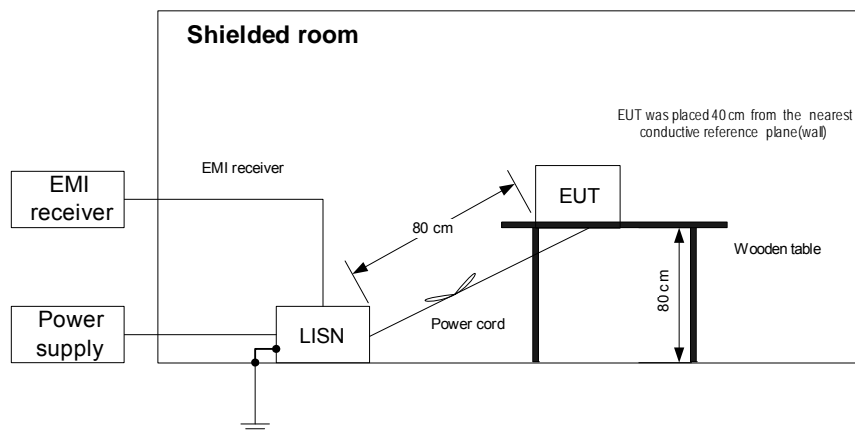



HERMON LABORATORIES

Test specification: Section 15.207(a), Conducted emission	
Test procedure: ANSI C63.4, Section 13.1.3	
Test mode: Compliance	Verdict: PASS
Date: 12/28/2010	
Temperature: 23.6 °C	Air Pressure: 1015 hPa
Relative Humidity: 32 %	
Power Supply: 120 VAC	
Remarks:	

Table 7.8.2 Conducted emission test results

LINE: AC mains
 EUT OPERATING MODE: Transmit
 EUT SET UP: TABLE-TOP
 TEST SITE: SHIELDED ROOM
 DETECTORS USED: PEAK / QUASI-PEAK / AVERAGE
 FREQUENCY RANGE: 150 kHz - 30 MHz
 RESOLUTION BANDWIDTH: 9 kHz

Frequency, MHz	Peak emission, dB(μV)	Quasi-peak			Average			Line ID	Verdict
		Measured emission, dB(μV)	Limit, dB(μV)	Margin, dB*	Measured emission, dB(μV)	Limit, dB(μV)	Margin, dB*		
0.153739	48.93	43.47	65.82	-22.35	21.76	55.82	-34.06	L1	Pass
0.197393	46.11	39.49	63.75	-24.26	17.50	53.75	-36.25		
0.248931	41.78	35.47	61.82	-26.35	16.81	51.82	-35.01		
0.154862	49.11	41.40	65.76	-24.36	18.24	55.76	-37.52	L2	Pass
0.198162	43.42	36.19	63.72	-27.53	13.82	53.72	-39.90		
0.253316	39.45	33.52	61.69	-28.17	14.14	51.69	-37.55		

*- Margin = Measured emission - specification limit.

Reference numbers of test equipment used

HL 0787	HL 1205	HL 1425	HL 1513	HL 2888	HL 3612		
---------	---------	---------	---------	---------	---------	--	--

Full description is given in Appendix A.

Test specification: Section 15.207(a), Conducted emission			
Test procedure: ANSI C63.4, Section 13.1.3			
Test mode: Compliance	Verdict: PASS		
Date: 12/28/2010			
Temperature: 23.6 °C	Air Pressure: 1015 hPa	Relative Humidity: 32 %	Power Supply: 120 VAC
Remarks:			

Plot 7.8.1 Conducted emission measurements

LINE: L1
EUT OPERATING MODE: Transmit
LIMIT: QUASI-PEAK, AVERAGE
DETECTOR: PEAK

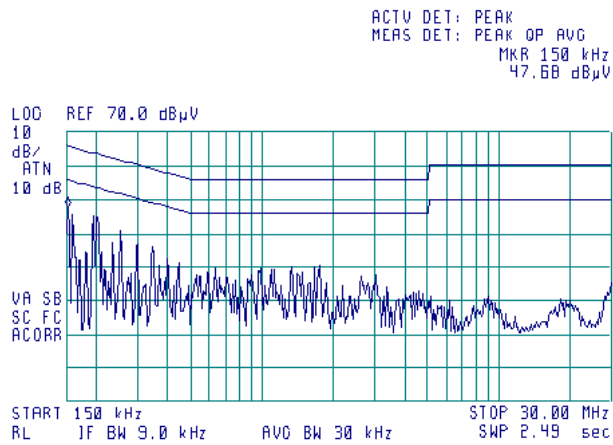

Plot 7.8.2 Conducted emission measurements

LINE: L2
EUT OPERATING MODE: Transmit
LIMIT: QUASI-PEAK, AVERAGE
DETECTOR: PEAK

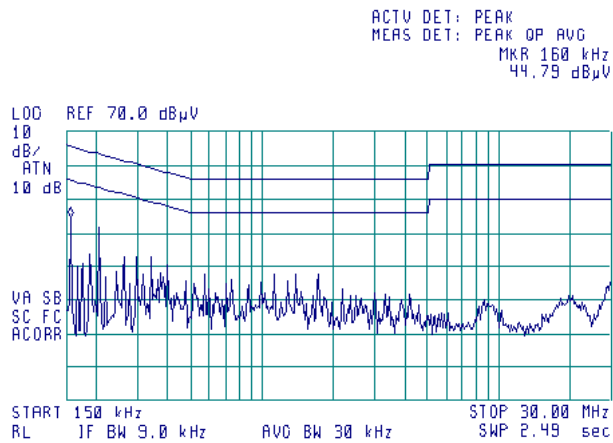

Test specification:	Section 15.203, Antenna requirements		
Test procedure:	Public notice DA 00-705		
Test mode:	Compliance	Verdict:	PASS
Date:	12/13/2010		
Temperature: 25 °C	Air Pressure: 1018 hPa	Relative Humidity: 38 %	Power Supply: 120 VAC
Remarks:			

7.9 Antenna requirements

The EUT was verified for compliance with antenna requirements. A transmitter shall be designed to ensure that no antenna other than that furnished by the responsible party will be used with the device. It may be either permanently attached or employs a unique antenna connector for every antenna proposed for use with the EUT. This requirement does not apply to professionally installed transmitters.

The rationale for compliance with the above requirements was either visual inspection results or supplier declaration. The summary of results is provided in Table 7.9.1.

Table 7.9.1 Antenna requirements

Requirement	Rationale	Verdict
The transmitter antenna is permanently attached	Visual inspection	Comply
The transmitter employs a unique antenna connector	NA	
The transmitter requires professional installation	NA	

8 APPENDIX A Test equipment and ancillaries used for tests

HL No	Description	Manufacturer	Model	Ser. No.	Last Cal.	Due Cal.
0446	Antenna, Loop, Active, 10 kHz - 30 MHz	EMCO	6502	2857	29-Jun-10	29-Jun-11
0521	EMI Receiver (Spectrum Analyzer) with RF filter section 9 kHz-6.5 GHz	Hewlett Packard	8546A	3617A 00319, 3448A002 53	25-Aug-10	25-Aug-11
0604	Antenna BiconiLog Log-Periodic/T Bow-TIE, 26 - 2000 MHz	EMCO	3141	9611-1011	11-Jan-10	11-Jan-11
0787	Transient Limiter 9 kHz-200 MHz	Hewlett Packard	11947A	3107A018 77	18-Oct-10	18-Oct-11
1205	One phase voltage regulator, 2kVA, 0-250V	Hermon Laboratories	TDGC-2	109	18-Jul-10	18-Jul-11
1425	EMI Receiver, 9 kHz - 2.9 GHz, System: HL1426, HL1427	Agilent Technologies	8542E	3710A002 22, 3705A002 04	24-Aug-10	24-Aug-11
1431	Receiver RF Section, 9 kHz-2.9 GHz, part of HL1430 system	Agilent Technologies	85422E	308070026 2	25-Nov-10	25-Nov-11
1513	Cable RF, 8 m, BNC/BNC	Belden	M17/167 MIL-C-17	1513	01-Sep-10	01-Sep-11
1984	Antenna, Double-Ridged Waveguide Horn, 1-18 GHz, 300 W	EMC Test Systems	3115	9911-5964	11-Jun-10	11-Jun-11
2780	EMC analyzer, 100 Hz to 26.5 GHz	Agilent Technologies	E7405A	MY451024 62	07-Jul-10	07-Jul-11
2870	Microwave Cable Assembly, 18 GHz, 6.4 m, SMA - SMA	Huber-Suhner	198-9155- 00	2870	30-Dec-10	30-Dec-11
2871	Microwave Cable Assembly, 18 GHz, 6.4 m, SMA - SMA	Huber-Suhner	198-8155- 00	2871	14-Sep-10	14-Sep-11
2883	Cable, 18 GHz N-type, M-F, 3 m	Bird Electronic Corp.	TC- MNFN-3.0	211539 003	01-Dec-10	01-Dec-11
2888	LISN Two-line V-Network 50 Ohm / 50 uH + 5 Ohm, 16A, MIL STD 461E, CISPR 16-1	Rolf Heine	NNB- 2/16Z	02/10018	07-Jul-10	07-Jul-11
3119	Cable, 18 GHz N-type, M-F, 3 m	Bird Electronic Corp.	TC- MNFN-3.0	211539004	03-Oct-10	03-Oct-11
3334	Filter, High Pass, 2.5 GHz	LORCH MICROWAVE	5HP7- 2500-SR	Z22	04-Oct-10	04-Oct-11
3342	High Pass Filter, 50 Ohm, 2000 to 5200 MHz.	Mini-Circuits	VHF- 1910+	NA	04-Oct-10	04-Oct-11
3386	Microwave Cable Assembly, 26.5 GHz, 1.0 m, N type/N type	Suhner Sucoflex	104EA	3386	25-Feb-10	25-Feb-11
3612	Cable RF, 17.5 m, N type-N type	Teldor	RG-214/U	NA	01-Dec-10	01-Dec-11
3622	Cable RF, 6.0 m, N type-N type, DC-6.5 GHz	Alpha Wire	RG 214/U	NA	27-May-10	27-May-11
3883	Preamplifier, 0.1 to 18 GHz, Gain 25 dB, N-type (f) in, N-type (m) out.	Agilent Technologies	87405C	MY470104 06	13-Jan-10	13-Jan-11
4051	Variac (Contact voltage regulator), 3kVA, 1phase, current rated 12A	Hermon Laboratories	TDGC20- 3	NA	28-Oct-10	28-Oct-11

9 APPENDIX B Measurement uncertainties

Expanded uncertainty at 95% confidence in Hermon Labs EMC measurements

Test description	Expanded uncertainty
Conducted carrier power at RF antenna connector	Below 12.4 GHz: ± 1.7 dB 12.4 GHz to 40 GHz: ± 2.3 dB
Conducted emissions at RF antenna connector	9 kHz to 2.9 GHz: ± 2.6 dB 2.9 GHz to 6.46 GHz: ± 3.5 dB 6.46 GHz to 13.2 GHz: ± 4.3 dB 13.2 GHz to 22.0 GHz: ± 5.0 dB 22.0 GHz to 26.8 GHz: ± 5.5 dB 26.8 GHz to 40.0 GHz: ± 4.8 dB
Occupied bandwidth	± 8.0 %
Duty cycle, timing (Tx ON / OFF) and average factor measurements	± 1.0 %
Conducted emissions with LISN	9 kHz to 150 kHz: ± 3.9 dB 150 kHz to 30 MHz: ± 3.8 dB
Radiated emissions at 3 m measuring distance Horizontal polarization Vertical polarization	Biconilog antenna: ± 5.3 dB Biconical antenna: ± 5.0 dB Log periodic antenna: ± 5.3 dB Double ridged horn antenna: ± 5.3 dB Biconilog antenna: ± 6.0 dB Biconical antenna: ± 5.7 dB Log periodic antenna: ± 6.0 dB Double ridged horn antenna: ± 6.0 dB

Hermon Laboratories is accredited by A2LA for calibration according to present requirements of ISO/IEC 17025 and NCSL Z540-1. The accreditation is granted to perform calibration of parameters that are listed in the Scope of Hermon Laboratories Accreditation.

Hermon Laboratories calibrates its reference and transfer standards by calibration laboratories accredited to ISO/IEC 17025 by a mutually recognized Accreditation Body or by a recognized national metrology institute. All reference and transfer standards used in the calibration system are traceable to national or international standards.

In-house calibration of all test and measurement equipment is performed on a regular basis according to Hermon Laboratories calibration procedures, manufacturer calibration/verification procedures or procedures defined in the relevant standards. The Hermon Laboratories test and measurement equipment is calibrated within the tolerances specified by the manufacturers and/or by the relevant standards.

10 APPENDIX C Test laboratory description

Tests were performed at Hermon Laboratories Ltd., which is a fully independent, private, EMC, safety, environmental and telecommunication testing facility.

Hermon Laboratories is listed by the Federal Communications Commission (USA) for all parts of Code of Federal Regulations 47 (CFR 47), Registration Numbers 90624 for OATS and 90623 for the anechoic chamber; by Industry Canada for electromagnetic emissions (file numbers IC 2186A-1 for OATS, IC 2186A-2 for anechoic chamber, IC 2186A-3 for full-anechoic chamber for RE measurements above 1 GHz), certified by VCCI, Japan (the registration numbers are R-808 for OATS, R-1082 for anechoic chamber, G-27 for full-anechoic chamber for RE measurements above 1 GHz, C-845 for conducted emissions site, T-1606 for conducted emissions at telecommunication ports), has a status of a Telefication - Listed Testing Laboratory, Certificate No. L138/00. The laboratory is accredited by American Association for Laboratory Accreditation (USA) according to ISO/IEC 17025 for electromagnetic compatibility, product safety, telecommunications testing and environmental simulation (for exact scope please refer to Certificate No. 839.01). The FCC Designation Number is US1003.

Address: P.O. Box 23, Binyamina 30500, Israel.
Telephone: +972 4628 8001
Fax: +972 4628 8277
e-mail: mail@hermonlabs.com
website: www.hermonlabs.com

Person for contact: Mr. Alex Usoskin, CEO.

11 APPENDIX D Specification references

FCC 47CFR part 15: 2009	Radio Frequency Devices
Public notice DA 00- 705: 2000	Filing and measurement guidelines for frequency hopping spread spectrum systems.
ANSI C63.2: 1996	American National Standard for Instrumentation-Electromagnetic Noise and Field Strength, 10 kHz to 40 GHz-Specifications
ANSI C63.4: 2003	American National Standard for Methods of Measurement of Radio-Noise Emissions from Low-Voltage Electrical and Electronic Equipment in the Range of 9 kHz to 40 GHz

12 APPENDIX E Test equipment correction factors

Correction factor
Line impedance stabilization network
Model NNB-2/16Z, Rolf Heine, HL 2888

Frequency, kHz	Insertion loss, dB		Measurement Uncertainty, dB
	L1	N	
10	0.48	0.79	±0.6
20	0.52	0.63	
30	0.31	0.35	
40	0.20	0.22	
50	0.16	0.17	
100	0.10	0.08	
300	0.08	0.06	
500	0.10	0.06	
600	0.09	0.07	
800	0.10	0.07	
1000	0.10	0.08	
2000	0.12	0.11	
3000	0.16	0.14	
4000	0.17	0.18	
6000	0.26	0.23	
10000	0.49	0.41	
14000	0.66	0.54	
16000	0.79	0.69	
18000	0.86	0.76	
20000	0.96	0.85	
25000	1.22	1.08	
28000	1.35	1.21	
30000	1.43	1.29	

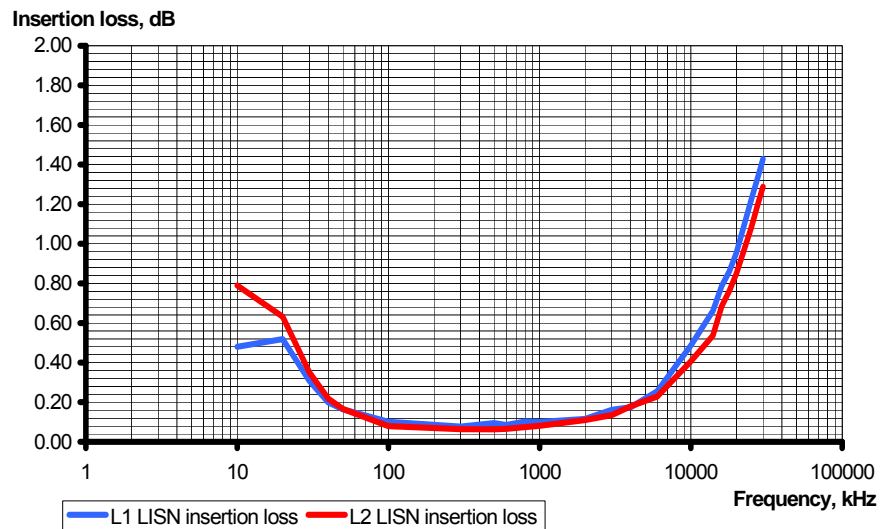

Antenna factor
Active loop antenna
Model 6502, S/N 2857, HL 0446

Frequency, MHz	Magnetic antenna factor, dB	Electric antenna factor, dB
0.009	-32.8	18.7
0.010	-33.8	17.7
0.020	-38.3	13.2
0.050	-41.1	10.4
0.075	-41.3	10.2
0.100	-41.6	9.9
0.150	-41.7	9.8
0.250	-41.6	9.9
0.500	-41.8	9.8
0.750	-41.9	9.7
1.000	-41.4	10.1
2.000	-41.5	10.0
3.000	-41.4	10.2
4.000	-41.4	10.1
5.000	-41.5	10.1
10.000	-41.9	9.6
15.000	-41.9	9.6
20.000	-42.2	9.3
25.000	-42.8	8.7
30.000	-44.0	7.5

Antenna factor in dB(1/m) is to be added to receiver meter reading in dB(μ V) to convert it into field intensity in dB(μ V/m).

Antenna factor
Biconilog antenna EMCO Model 3141
Ser.No.1011, HL 0604

Frequency, MHz	Antenna Factor, dB(1/m)	Frequency, MHz	Antenna Factor, dB(1/m)
26	7.8	940	24.0
28	7.8	960	24.1
30	7.8	980	24.5
40	7.2	1000	24.9
60	7.1	1020	25.0
70	8.5	1040	25.2
80	9.4	1060	25.4
90	9.8	1080	25.6
100	9.7	1100	25.7
110	9.3	1120	26.0
120	8.8	1140	26.4
130	8.7	1160	27.0
140	9.2	1180	27.0
150	9.8	1200	26.7
160	10.2	1220	26.5
170	10.4	1240	26.5
180	10.4	1260	26.5
190	10.3	1280	26.6
200	10.6	1300	27.0
220	11.6	1320	27.8
240	12.4	1340	28.3
260	12.8	1360	28.2
280	13.7	1380	27.9
300	14.7	1400	27.9
320	15.2	1420	27.9
340	15.4	1440	27.8
360	16.1	1460	27.8
380	16.4	1480	28.0
400	16.6	1500	28.5
420	16.7	1520	28.9
440	17.0	1540	29.6
460	17.7	1560	29.8
480	18.1	1580	29.6
500	18.5	1600	29.5
520	19.1	1620	29.3
540	19.5	1640	29.2
560	19.8	1660	29.4
580	20.6	1680	29.6
600	21.3	1700	29.8
620	21.5	1720	30.3
640	21.2	1740	30.8
660	21.4	1760	31.1
680	21.9	1780	31.0
700	22.2	1800	30.9
720	22.2	1820	30.7
740	22.1	1840	30.6
760	22.3	1860	30.6
780	22.6	1880	30.6
800	22.7	1900	30.6
820	22.9	1920	30.7
840	23.1	1940	30.9
860	23.4	1960	31.2
880	23.8	1980	31.6
900	24.1	2000	32.0
920	24.1		

Antenna factor in dB(1/m) is to be added to receiver meter reading in dB(μ V) to convert it into field intensity in dB(μ V/m).

Antenna factor
Double-ridged wave guide horn antenna
Model 3115, S/N 9911-5964, HL1984

Frequency, MHz	Antenna factor, dB(1/m)
1000.0	24.7
1500.0	25.7
2000.0	27.6
2500.0	28.9
3000.0	31.2
3500.0	32.0
4000.0	32.5
4500.0	32.7
5000.0	33.6
5500.0	35.1
6000.0	35.4
6500.0	34.9
7000.0	36.1
7500.0	37.8
8000.0	38.0
8500.0	38.1
9000.0	39.1
9500.0	38.3
10000.0	38.6
10500.0	38.2
11000.0	38.7
11500.0	39.5
12000.0	40.0
12500.0	40.4
13000.0	40.5
13500.0	41.1
14000.0	41.6
14500.0	41.7
15000.0	38.7
15500.0	38.2
16000.0	38.8
16500.0	40.5
17000.0	42.5
17500.0	45.9
18000.0	49.4

Antenna factor in dB(1/m) is to be added to receiver meter reading in dB(μ V) to convert it into field intensity in dB(μ V/m).

Cable loss
Cable coaxial, Huber-Suhner, 18 GHz, 6.4 m, SMA - SMA, model 198-9155-00,
HL 2870

Frequency, MHz	Cable loss, dB	Frequency, MHz	Cable loss, dB	Frequency, MHz	Cable loss, dB
10	0.09	5750	2.49	12000	3.71
30	0.17	6000	2.53	12250	3.81
100	0.32	6250	2.58	12500	3.84
250	0.49	6500	2.64	12750	3.88
500	0.70	6750	2.69	13000	3.92
750	0.86	7000	2.75	13250	3.96
1000	1.00	7250	2.80	13500	3.98
1250	1.11	7500	2.87	13750	4.01
1500	1.23	7750	2.93	14000	4.03
1750	1.34	8000	2.94	14250	4.09
2000	1.41	8250	3.00	14500	4.08
2250	1.51	8500	3.04	14750	4.10
2500	1.59	8750	3.08	15000	4.15
2750	1.68	9000	3.14	15250	4.22
3000	1.76	9250	3.16	15500	4.31
3250	1.83	9500	3.22	15750	4.42
3500	1.91	9750	3.26	16000	4.48
3750	1.97	10000	3.36	16250	4.54
4000	2.05	10250	3.41	16500	4.56
4250	2.11	10500	3.46	16750	4.57
4500	2.18	10750	3.50	17000	4.59
4750	2.24	11000	3.54	17250	4.66
5000	2.30	11250	3.58	17500	4.70
5250	2.36	11500	3.63	17750	4.76
5500	2.43	11750	3.66	18000	4.72

Cable loss
Cable coaxial, Huber-Suhner, 18 GHz, 6.4 m, SMA - SMA, model 198-8155-00,
HL 2871

Frequency, MHz	Cable loss, dB	Frequency, MHz	Cable loss, dB	Frequency, MHz	Cable loss, dB
10	0.12	5750	2.34	12000	3.55
30	0.14	6000	2.39	12250	3.61
100	0.27	6250	2.46	12500	3.67
250	0.45	6500	2.52	12750	3.74
500	0.63	6750	2.58	13000	3.79
750	0.76	7000	2.64	13250	3.82
1000	0.89	7250	2.68	13500	3.83
1250	1.01	7500	2.73	13750	3.83
1500	1.12	7750	2.78	14000	3.88
1750	1.23	8000	2.83	14250	3.93
2000	1.32	8250	2.88	14500	3.96
2250	1.41	8500	2.94	14750	4.01
2500	1.49	8750	2.97	15000	4.00
2750	1.58	9000	3.02	15250	4.01
3000	1.66	9250	3.07	15500	4.00
3250	1.73	9500	3.13	15750	4.13
3500	1.80	9750	3.18	16000	4.22
3750	1.87	10000	3.21	16250	4.29
4000	1.93	10250	3.26	16500	4.29
4250	2.01	10500	3.30	16750	4.32
4500	2.06	10750	3.36	17000	4.37
4750	2.12	11000	3.39	17250	4.45
5000	2.17	11250	3.44	17500	4.49
5250	2.24	11500	3.48	17750	4.53
5500	2.29	11750	3.52	18000	4.55

Cable loss
Cable coaxial, Bird, 18 GHz, N-type, M-F, model TC-MNFN-3.0, S/N 211539 003
HL 2883

Frequency, MHz	Cable loss, dB	Frequency, MHz	Cable loss, dB	Frequency, MHz	Cable loss, dB
10	0.06	5750	1.70	12000	2.46
30	0.12	6000	1.75	12250	2.48
100	0.21	6250	1.80	12500	2.52
250	0.34	6500	1.81	12750	2.50
500	0.47	6750	1.86	13000	2.54
750	0.59	7000	1.86	13250	2.48
1000	0.67	7250	1.92	13500	2.63
1250	0.76	7500	1.96	13750	2.65
1500	0.84	7750	1.98	14000	2.72
1750	0.92	8000	2.02	14250	2.67
2000	0.98	8250	2.03	14500	2.70
2250	1.05	8500	2.05	14750	2.72
2500	1.12	8750	2.11	15000	2.79
2750	1.17	9000	2.17	15250	2.80
3000	1.22	9250	2.17	15500	2.83
3250	1.27	9500	2.20	15750	2.75
3500	1.33	9750	2.19	16000	2.82
3750	1.38	10000	2.22	16250	2.85
4000	1.42	10250	2.25	16500	2.90
4250	1.46	10500	2.30	16750	2.89
4500	1.51	10750	2.28	17000	2.88
4750	1.54	11000	2.32	17250	2.85
5000	1.59	11250	2.34	17500	2.96
5250	1.62	11500	2.39	17750	3.04
5500	1.65	11750	2.42	18000	3.04

Cable loss
Cable 18 GHz, N-type, M-F, 3 m, Bird Electronic Corp., model TC-MNFN-3.0, S/N 211539004
HL 3119

Frequency, MHz	Cable loss, dB	Frequency, MHz	Cable loss, dB	Frequency, MHz	Cable loss, dB	Frequency, MHz	Cable loss, dB	Frequency, MHz	Cable loss, dB
10	0.06	3600	1.34	7400	2.00	11200	2.48	15100	2.90
30	0.09	3700	1.36	7500	2.01	11300	2.45	15200	2.89
50	0.11	3800	1.37	7600	2.03	11400	2.51	15300	2.91
100	0.23	3900	1.39	7700	2.05	11500	2.45	15400	2.85
200	0.30	4000	1.39	7800	2.07	11600	2.49	15500	2.83
300	0.42	4100	1.42	7900	2.06	11700	2.51	15600	2.89
400	0.39	4200	1.45	8000	2.06	11800	2.50	15700	2.85
500	0.47	4300	1.47	8100	2.09	11900	2.52	15800	2.87
600	0.49	4400	1.49	8200	2.10	12000	2.48	15900	2.91
700	0.63	4500	1.51	8300	2.11	12100	2.53	16000	2.90
800	0.62	4600	1.53	8400	2.15	12200	2.54	16100	2.94
900	0.70	4700	1.55	8500	2.15	12300	2.56	16200	2.91
1000	0.70	4800	1.54	8600	2.17	12400	2.57	16300	2.96
1100	0.77	4900	1.57	8700	2.19	12500	2.57	16400	3.01
1200	0.78	5000	1.60	8800	2.20	12600	2.55	16500	3.01
1300	0.83	5100	1.60	8900	2.21	12700	2.50	16600	2.98
1400	0.86	5200	1.62	9000	2.22	12800	2.57	16700	3.00
1500	0.85	5300	1.65	9100	2.23	12900	2.57	16800	3.01
1600	0.94	5400	1.66	9200	2.25	13000	2.55	16900	3.06
1700	0.90	5500	1.69	9300	2.24	13100	2.62	17000	3.07
1800	0.90	5600	1.70	9400	2.28	13200	2.60	17100	3.09
1900	0.95	5700	1.72	9500	2.28	13300	2.67	17200	3.10
2000	0.97	5800	1.74	9600	2.27	13400	2.66	17300	3.11
2100	1.00	5900	1.75	9700	2.30	13500	2.71	17400	3.16
2200	1.02	6000	1.77	9800	2.30	13600	2.73	17500	3.15
2300	1.05	6100	1.79	9900	2.34	13700	2.73	17600	3.21
2400	1.08	6200	1.82	10000	2.32	13800	2.85	17700	3.21
2500	1.10	6300	1.83	10100	2.31	13900	2.83	17800	3.18
2600	1.13	6400	1.83	10200	2.31	14000	2.83	17900	3.25
2700	1.15	6500	1.87	10300	2.26	14100	2.83	18000	3.14
2800	1.17	6600	1.88	10400	2.32	14200	2.84		
2900	1.21	6700	1.90	10500	2.26	14300	2.90		
3000	1.22	6800	1.93	10600	2.26	14400	2.84		
3100	1.25	6900	1.92	10700	2.31	14600	2.88		
3200	1.27	7000	1.95	10800	2.24	14700	2.85		
3300	1.29	7100	1.96	10900	2.39	14800	2.92		
3400	1.28	7200	1.99	11000	2.41	14900	2.93		
3500	1.31	7300	2.00	11100	2.46	15000	2.83		

Cable loss
Cable coaxial, Microwave Cable Assembly, 104EA, 18 GHz, 1.0 m
Suhner Sucoflex, HL 3386

Frequency, MHz	Cable loss, dB	Frequency, MHz	Cable loss, dB	Frequency, MHz	Cable loss, dB
10	0.05	5750	1.01	12000	1.29
30	0.07	6000	1.02	12250	1.33
100	0.12	6250	1.02	12500	1.36
250	0.18	6500	0.95	12750	1.35
500	0.26	6750	0.96	13000	1.36
750	0.32	7000	1.01	13250	1.39
1000	0.35	7250	1.04	13500	1.37
1250	0.41	7500	1.09	13750	1.43
1500	0.45	7750	1.12	14000	1.46
1750	0.50	8000	1.13	14250	1.39
2000	0.54	8250	1.15	14500	1.36
2250	0.57	8500	1.15	14750	1.47
2500	0.61	8750	1.15	15000	1.47
2750	0.64	9000	1.16	15250	1.41
3000	0.67	9250	1.14	15500	1.52
3250	0.70	9500	1.14	15750	1.54
3500	0.71	9750	1.19	16000	1.49
3750	0.74	10000	1.20	16250	1.48
4000	0.77	10250	1.22	16500	1.52
4250	0.80	10500	1.23	16750	1.56
4500	0.84	10750	1.22	17000	1.57
4750	0.85	11000	1.21	17250	1.53
5000	0.84	11250	1.24	17500	1.55
5250	0.85	11500	1.26	17750	1.55
5500	0.92	11750	1.28	18000	1.54

Cable loss
Cable coaxial, RG-214/U, N type-N type, 17 m
Teldor, HL 3612

Frequency, MHz	Cable loss, dB
0.1	0.05
0.5	0.07
1	0.10
3	0.22
5	0.29
10	0.39
30	0.68
50	0.90
100	1.27
150	1.58
200	1.80
250	2.12
300	2.36
350	2.60
400	2.82
450	2.99
500	3.23
550	3.40
600	3.56
650	3.71
700	3.90
750	4.04
800	4.23
850	4.39
900	4.55
950	4.65
1000	4.79

Cable loss
Cable coaxial, RG-214/U, N type-N type, 6 m
Alpha Wire, HL 3622

Frequency, MHz	Cable loss, dB	Frequency, MHz	Cable loss, dB	Frequency, MHz	Cable loss, dB
10	0.13	2100	2.95	4400	4.99
30	0.24	2200	2.99	4500	5.00
50	0.32	2300	3.11	4600	5.17
100	0.47	2400	3.16	4700	5.18
200	0.70	2500	3.31	4800	5.33
300	0.88	2600	3.36	4900	5.34
400	1.05	2700	3.46	5000	5.50
500	1.21	2800	3.52	5100	5.56
600	1.36	2900	3.65	5200	5.76
700	1.49	3000	3.70	5300	5.76
800	1.63	3100	3.82	5400	5.85
900	1.72	3200	3.88	5500	5.88
1000	1.84	3300	3.99	5600	5.96
1100	1.96	3400	4.08	5700	6.02
1200	2.06	3500	4.19	5800	6.06
1300	2.15	3600	4.28	5900	6.14
1400	2.28	3700	4.42	6000	6.17
1500	2.35	3800	4.40	6100	6.28
1600	2.43	3900	4.51	6200	6.36
1700	2.57	4000	4.62	6300	6.47
1800	2.62	4100	4.70	6400	6.51
1900	2.75	4200	4.78	6500	6.65
2000	2.80	4300	4.83		

13 APPENDIX F Abbreviations and acronyms

A	ampere
AC	alternating current
A/m	ampere per meter
AM	amplitude modulation
AVRG	average (detector)
cm	centimeter
dB	decibel
dBm	decibel referred to one milliwatt
dB(μ V)	decibel referred to one microvolt
dB(μ V/m)	decibel referred to one microvolt per meter
dB(μ A)	decibel referred to one microampere
DC	direct current
EIRP	equivalent isotropically radiated power
ERP	effective radiated power
EUT	equipment under test
F	frequency
GHz	gigahertz
GND	ground
H	height
HL	Hermon laboratories
Hz	hertz
k	kilo
kHz	kilohertz
LO	local oscillator
m	meter
MHz	megahertz
min	minute
mm	millimeter
ms	millisecond
μ s	microsecond
NA	not applicable
NB	narrow band
OATS	open area test site
Ω	Ohm
PM	pulse modulation
PS	power supply
ppm	part per million (10^{-6})
QP	quasi-peak
RE	radiated emission
RF	radio frequency
rms	root mean square
Rx	receive
s	second
T	temperature
Tx	transmit
V	volt
WB	wideband

END OF DOCUMENT