



MP-843/XHM2

ZigBee 3.0 Home Automation

Wireless Digital Pet Immune PIR Motion Detector

Introduction

The MP-843/XHM2 PIR motion detector is wireless, digital, and immune to the movements of pets. The detector is controlled by a micro-processor and supports ZigBee 3.0. The detector has the following features:

- Detection distance of up to 49 ft.
- Uniform detection.
- White light immunity
Note: This feature is not evaluated by UL.
- Target Specific Imaging™ (TSI) enables immunity from pets weighing up to 85 lb.
Note: This specification is not evaluated by UL.
- The patented True Motion Recognition™ algorithm enhances false alarm rejection.
- Requires no vertical adjustment.
- To save battery power, the detector goes to sleep after a detection while in normal mode. If there is no detection during the following 2-minute period, the detector returns to a ready state.
- Temperature compensation.
- Front tamper protection.
- Black mirror technology provides excellent white light protection.
- Elegant, sturdy case.

Figure 1: Legend

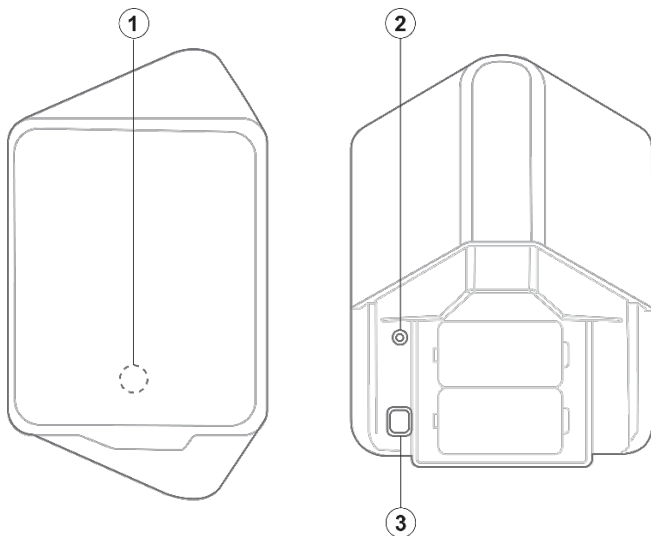

Callout	Description
1	Red LED
2	Green LED
3	Tamper switch

Specifications

- Detector type: dual element low-noise pyroelectric sensor
- Optical data:
 - 9 far parabolic black mirrors provide 18 beams.
 - 5 near cylinder black mirrors provide 10 curtains.
 - An optical attenuator on the mirror provides pet immunity protection.
- Maximum coverage: 90° and 15 x 15 m or 49.2 ft x 49.2 ft

- Pet immunity: up to 85 lb

Electrical

- Internal batteries: two 3 V CR-123A lithium batteries.

Note: For UL installations, use only GP batteries.

- Nominal battery capacity: 1400 mAh
- Battery life: over 5 years *

Note:

- The battery life reduces faster if the device cannot connect to a wireless network or the wireless connection quality is lower than 20%.
- This specification is not evaluated by UL.
- Battery power test: occurs when you insert the battery and periodically every several hours

Functional

- Alarm period: 3 s
- Visual indications:
 - The red LED lights for 3 seconds when the detector transmits an alarm or tamper message.
 - The red LED lights for 3 seconds when the detector detects motion while it is in walk test mode.
Note: Outside of walk test mode, the red LED does not light when the detector detects alarm, or when it sends transmission or supervision messages.
 - The red LED flashes during the power-up stabilization period and when you press the tamper switch
- Rearm timer: rearms the detector 2 minutes after the last alarm. The timer is disabled in walk test mode.

Wireless

- Supported network: ZigBee 3.0
- Frequency: 2.405 to 2.480 Ghz as per IEEE 802.15.4
- Tamper alert: reports when a tamper event occurs and in any subsequent message until the tamper switch is restored

Mounting

- Height: 6 ft to 7 ft. For pet immunity, the optimal height is 7 ft.
- Installation options: flat surface or corner

Environmental

- RFI protection: >20 V/m up to 1000 MHz
- Operating temperatures: -10°C or 14°F to 50°C or 122°F
- Storage temperatures: -20°C or -4°F to 60°C or 140°F

Physical

- Size (H x W x D): 4.68 in. x 3.11 in. x 1.31 in.
- Weight including batteries: 4.2 oz.
- Color: white
- Patent: U.S. patents 5,693,943 and 6,211,522

Installation

General Guidance

Note: Install the device in accordance with the Standard for Installation and Classification of Residential Alarm Systems, UL 1641. Do not install the device in any of the following locations. See Figure 2:

1. Near high-voltage electrical lines
2. Near heat sources
3. Outdoors
4. In direct sunshine
5. In an area exposed to air drafts

6. Behind partitions or objects
7. On unstable surfaces

Warning: Do not obscure partially or completely the detector's field of view.

Figure 2: General installation guidance

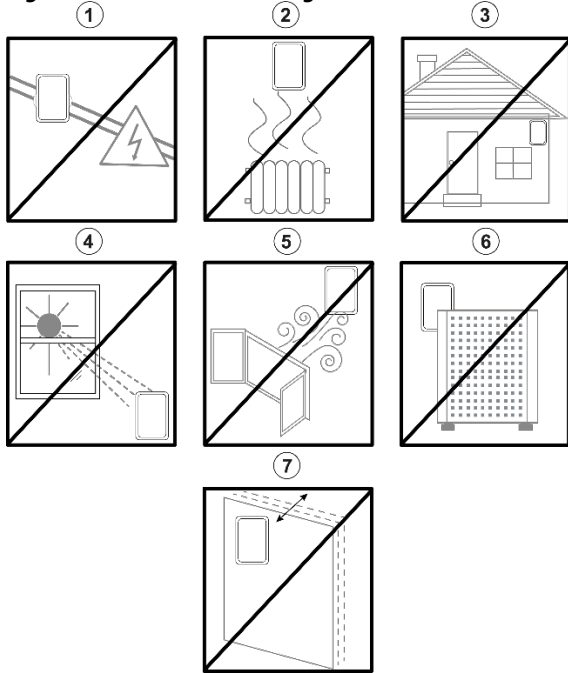

Mounting the MP-843/XHM2

1. To remove the bracket, turn the detector so that the flat side is facedown and the detector spine is faceup. Press the spine below the snap and slide off the cover. See Figure 3.
2. Mount the bracket on the wall with screws. To mount the bracket in a corner, use either hole set A1 or hole set A2. To mount the bracket on a flat surface or hole set B. See Figure 4.
3. Activate the detector with one of the following options:
 - If batteries are already installed, pull the activation tab that protrudes from the battery compartment. See Figure 5.
 - If there are no batteries, insert new ones with the correct polarity. For more information, see Inserting or replacing the batteries.
4. To mount the detector on the bracket, align the groove of the detector with the rail of the bracket and slide the detector downward until you hear a click.
5. When the unit is mounted in its final location and ready for the walk test, remove the protective film on the front of the unit.

Figure 3: Opening the unit

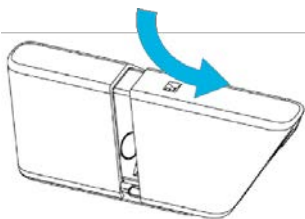

Figure 5: Removing the activation tab

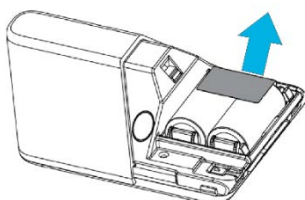

Figure 4: Bracket mounting

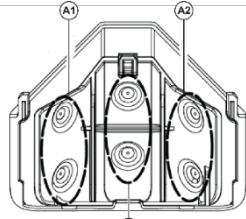
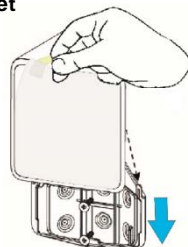

Figure 6: Mounting detector on bracket



Replacing the batteries

1. Press upward to slide off the detector from the bracket. See Figure 7.
2. **Optional:** Remove the batteries and wait for 1 minute.

Note: Dispose of used batteries according to the manufacturer's instructions.
3. Insert the new batteries.

Caution! Risk of explosion if battery is replaced with an incorrect type. For more information, see Batteries in Specifications.
4. To mount the detector on the bracket, slide it downward until you hear a click.

Figure 7: Replacing the batteries

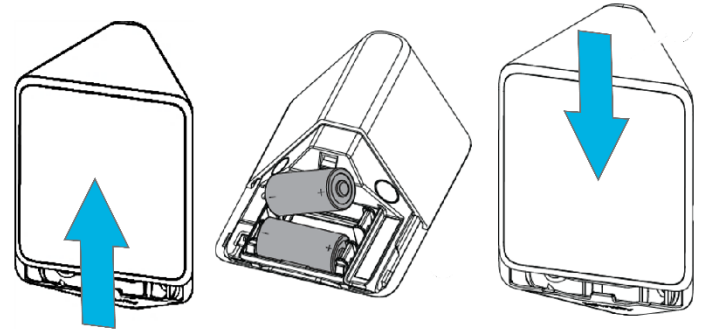

Pairing the detector and the panel

Pair the detector and control panel before you install the detector.

Note: For UL listed installations, only use the device with UL listed control panels.

1. Set the panel to pairing mode. For more information, refer to the panel user guide.
2. Set the detector to pairing mode.
3. To activate the detector, pull the activation strip that protrudes from the battery compartment. See Figure 5.
4. Verify that the detector is searching for the panel: the green LED blinks 3 times every 5 seconds and continues to blink for up to 1 minute.

Note: If you press the tamper switch or trip the motion detector, the search process fails and restarts.

5. Complete the pairing procedure on the touchscreen control panel. For more information, refer to the panel's installation guide.
6. On the panel screen, ensure that the Received Signal Strength Indicator (RSSI) is stronger than -70dBm and the Link Quality Indicator (LQI) is stronger than 250. If the RSSI and LQI values do not meet the minimum required values, change the location of the detector until they do.

Rebooting the detector

1. Remove the detector from the bracket. For more information, see step 1 in Mounting the detector.
2. Press and hold the tamper switch for 2 seconds. For more information on the tamper switch, see Figure 1.
3. Close the battery cover. For more information, see step 4 in Mounting the detector.

Resetting the detector to default mode

If you reset the detector to default mode, the device disconnects from the network and is ready to pair with the panel.

1. Remove the detector from the bracket. For more information, see step 1 in Mounting the detector.
2. Press and hold the tamper switch. For more information on the

- tamper switch, see Figure 1.
- Insert one of the two batteries into the battery compartment with correct polarity and release the tamper switch within 4 seconds. The LED blinks 3 times every 5 seconds.
 - Pair the detector. For more information on pairing the detector, see Pairing the detector and the panel.

Performing a walk test

Instruct the home owner to perform a walk test at least once a week to verify that the detector functions correctly.

- To put the detector in walk test mode, complete one of the following actions:
 - Insert the batteries. For more information, see Inserting or replacing the batteries.
 - Remove the detector from the bracket and then return it to the bracket to activate the tamper switch. For more information on returning the device to the bracket, see step 4 in Mounting the MP-843/XHM2.
- Wait for the detector to enter walk test mode. The red LED flashes for 2 minutes before the detector enters walk test mode. Walk test mode lasts 15 minutes.
- Walk across the far end of detector coverage pattern in both directions.
- Verify that the red LED lights for 2 to 3 seconds each time the detector detects your motion.

Note: In walk test mode the red LED lights for every motion detected. After 15 minutes the detector enters normal mode in which the LED will not blink when it detects movement.

Figure 8: Walk test detector coverage pattern

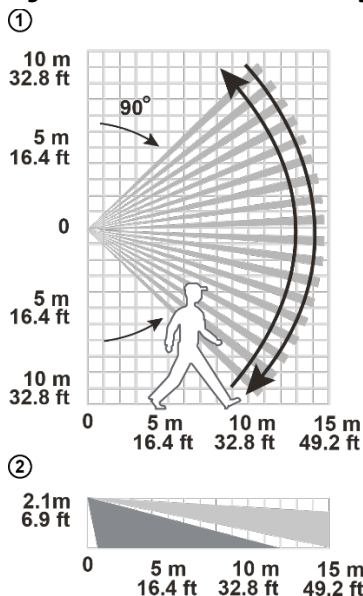

Callout	Description
1	Top view
2	Side view

Troubleshooting

If you encounter one of the following problems with the MP-843/XHM2, perform the suggested solution:

Problem	Solution
The detector and control panel do not pair successfully.	Reset the detector to default mode and pair the detector and the panel again. For more information, see Resetting the detector to default mode and

	Pairing the detector and the panel.
The detector and the panel do not communicate.	Try the following options: <ol style="list-style-type: none"> Ensure the RSSI and LQI meet the required values. For more information, see step 8 in Pairing the detector and the panel. Refer to the signal strength test procedure in the control panel installation guide. Replace the batteries.
The device transmits a low battery indication.	To ensure continuous full operation, replace both batteries within two weeks of the first low battery indication.
The panel does not arm because of an unrecognized detector malfunction.	Disable the zone. For more information, refer to the control panel user guide. <p>Note:</p> <ul style="list-style-type: none"> Consult with your installer or system provider before you disable a zone. The overall system security level lowers if you disable a detector zone.

Compliance with standards

The MP-843/XHM2 detector complies with the following standards:



USA: FCC-CFR 47 Part 15
 Canada: IC-RSS 247
 USA: UL-UL639
 Canada: ULC-S306

WARNING! Changes or modifications to this unit not expressly approved by the party responsible for compliance could void the user's authority to operate the equipment.

This device complies with Part 15 of the FCC Rules with Industry Canada license-exempt RSS standard(s). Operation is subject to the following two conditions: (1) this device may not cause interference, and (2) this device must accept any interference, including interference that may cause undesired operation of the device.

Le présent appareil est conforme aux CNR d'Industrie Canada applicables aux appareils radio exempts de licence. L'exploitation est autorisée aux deux conditions suivantes : (1) l'appareil ne doit pas produire de brouillage, et (2) l'utilisateur de l'appareil doit accepter tout brouillage radioélectrique subi, même si le brouillage est susceptible d'en compromettre le fonctionnement.

To comply with FCC Section 1.1310 for human exposure to radio frequency electromagnetic fields and IC requirements, implement the following instruction: A distance of at least 20cm. between the equipment and all persons should be maintained during the operation of the equipment.

Le dispositif doit être placé à une distance d'au moins 20 cm à partir de toutes les personnes au cours de son fonctionnement normal. Les antennes utilisées pour ce produit ne doivent pas être situés ou exploités conjointement avec une autre antenne ou transmetteur.

Note: This equipment has been tested and found to comply with the limits for a Class B digital device, pursuant to part 15 of the FCC Rules. These limits are designed to provide reasonable protection against harmful interference in a residential installation. This equipment

generates, uses and can radiate radio frequency energy and, if not installed and used in accordance with the instructions, may cause harmful interference to radio communications. However, there is no guarantee that interference will not occur in a particular installation. If this equipment does cause harmful interference to radio or television reception, which can be determined by turning the equipment off and on, the user is encouraged to try to correct the interference by one or more of the following measures:

- Reorient or relocate the receiving antenna.
- Increase the separation between the equipment and receiver.
- Connect the equipment into an outlet on a circuit different from that to which the receiver is connected.
- Consult the dealer or an experienced radio/TV technician for help.

This Class B digital apparatus complies with Canadian ICES-003.

Cet appareil numérique de la classe B est conforme à la norme NMB-003 du Canada.

Device failure

Even the most sophisticated detectors can sometimes be defeated or may fail to warn. Possible causes of failure are DC power failure or improper connection, malicious masking of the lens, tampering with the optical system, decreased sensitivity in ambient temperatures close to that of the human body and unexpected failure of a component part.

The above list includes the most common reasons for failure to detect intrusion, but is by no means comprehensive. It is therefore recommended that the detector and the entire alarm system be checked weekly, to ensure proper performance.

An alarm system should not be regarded as a substitute for insurance. Home and property owners or renters should continue to insure their lives and property, even though they are protected by an alarm system

Warranty

Visonic Limited (the "Manufacturer") warrants this product only (the "Product") to the original purchaser only (the "Purchaser") against defective workmanship and materials under normal use of the Product for a period of twelve (12) months from the date of shipment by the Manufacturer.

This Warranty is absolutely conditional upon the Product having been properly installed, maintained and operated under conditions of normal use in accordance with the Manufacturer's recommended installation and operation instructions. Products which have become defective for any other reason, according to the Manufacturer's discretion, such as improper installation, failure to follow recommended installation and operational instructions, neglect, willful damage, misuse or vandalism, accidental damage, alteration or tampering, or repair by anyone other than the manufacturer, are not covered by this Warranty.

There is absolutely no warranty on software, and all software products are sold as a user license under the terms of the software license agreement included with such Product.¹ The Manufacturer does not represent that this Product may not be compromised and/or circumvented or that the Product will prevent any death and/or personal injury and/or damage to property resulting from burglary, robbery, fire or otherwise, or that the Product will in all cases provide adequate warning or protection. The Product, properly installed and maintained, only reduces the risk of such events without warning and it is not a guarantee or insurance that such events will not occur.

Conditions to Void Warranty

This warranty applies only to defects in parts and workmanship relating to normal use of the Products. It does not cover:

- damage incurred in shipping or handling;
- damage caused by disaster such as fire, flood, wind, earthquake or lightning;
- damage due to causes beyond the control of the Seller such as excessive voltage, mechanical shock or water damage;
- damage caused by unauthorized attachment, alterations, modifications or foreign objects being used with or in conjunction with the Products;
- damage caused by peripherals (unless such peripherals were supplied by the Seller);
- defects caused by failure to provide a suitable installation environment for the products;
- damage caused by use of the Products for purposes other than those for which they were designed;
- damage from improper maintenance;
- damage arising out of any other abuse, mishandling or improper application of the Products.

Items Not Covered by Warranty

In addition to the items which void the Warranty, the following items shall not be covered by Warranty: (i) freight cost to the repair centre; (ii) customs fees, taxes, or VAT that may be due; (iii) Products which are not identified with the Seller's product label and lot number or serial number; (iv) Products disassembled or repaired in such a manner as to adversely affect performance or prevent adequate inspection or testing to verify any warranty claim. Access cards or tags returned for replacement under warranty will be credited or replaced at the Seller's option.

THIS WARRANTY IS EXCLUSIVE AND EXPRESSLY IN LIEU OF ALL OTHER WARRANTIES, OBLIGATIONS OR LIABILITIES, WHETHER WRITTEN, ORAL, EXPRESS OR IMPLIED, INCLUDING ANY WARRANTY OF MERCHANTABILITY OR FITNESS FOR A PARTICULAR PURPOSE, OR OTHERWISE. IN NO CASE SHALL THE MANUFACTURER BE LIABLE TO ANYONE FOR ANY CONSEQUENTIAL OR INCIDENTAL DAMAGES FOR BREACH OF THIS WARRANTY OR ANY OTHER WARRANTIES WHATSOEVER, AS AFORESAID. THE MANUFACTURER SHALL IN NO EVENT BE LIABLE FOR ANY SPECIAL, INDIRECT, INCIDENTAL, CONSEQUENTIAL OR PUNITIVE DAMAGES OR FOR LOSS, DAMAGE, OR EXPENSE, INCLUDING LOSS OF USE, PROFITS, REVENUE, OR GOODWILL, DIRECTLY OR INDIRECTLY ARISING FROM PURCHASER'S USE OR INABILITY TO USE THE PRODUCT, OR FOR LOSS OR DESTRUCTION OF OTHER PROPERTY OR FROM ANY OTHER CAUSE, EVEN IF MANUFACTURER HAS BEEN ADVISED OF THE POSSIBILITY OF SUCH DAMAGE. THE MANUFACTURER SHALL HAVE NO LIABILITY FOR ANY DEATH, PERSONAL AND/OR BODILY INJURY AND/OR DAMAGE TO PROPERTY OR OTHER LOSS WHETHER DIRECT, INDIRECT, CONSEQUENTIAL OR OTHERWISE, BASED ON A CLAIM THAT THE PRODUCT FAILED TO FUNCTION. HOWEVER, IF THE MANUFACTURER IS HELD LIABLE, WHETHER DIRECTLY OR INDIRECTLY, FOR ANY LOSS OR DAMAGE ARISING UNDER THIS LIMITED WARRANTY, THE MANUFACTURER'S MAXIMUM LIABILITY (IF ANY) SHALL NOT IN ANY CASE EXCEED THE PURCHASE PRICE OF THE PRODUCT INVOLVED, WHICH SHALL BE FIXED AS LIQUIDATED DAMAGES AND NOT AS A PENALTY, AND SHALL BE THE COMPLETE AND EXCLUSIVE REMEDY AGAINST THE MANUFACTURER.

When accepting the delivery of the Product, the Purchaser agrees to the said conditions of sale and warranty and he recognizes having been informed of.

Some jurisdictions do not allow the exclusion or limitation of incidental or consequential damages, so these limitations may not apply under certain circumstances.

The Manufacturer shall be under no liability whatsoever arising out of the corruption and/or malfunctioning of any telecommunication or electronic equipment or any programs.

The Manufacturer's obligations under this Warranty are limited solely to repair and/or replace at the Manufacturer's discretion any Product or part thereof that may prove defective. Any repair and/or replacement shall not extend the original Warranty period. The Manufacturer shall not be responsible for dismantling and/or reinstallation costs. To exercise this Warranty the Product must be returned to the Manufacturer freight pre-paid and insured.

All freight and insurance costs are the responsibility of the Purchaser and are not included in this Warranty. **For sales in Israel only:**

The Purchaser shall comply with the provisions of the Israeli Consumer Protection Law – 1981 ("Consumer Protection Law") related regulations, including the Israeli Consumer Protection Regulations (Warranty Sticker), 5772-2012 ("Regulations"), including, without limitation (i) providing its customers with at least the minimum warranty required by the Consumer Protection Law, and (ii) ensuring that a warranty certificate and a warranty sticker (as defined in the Regulations) ("Warranty Sticker") shall be attached to any sold Products and the date of the sale of the Product to the consumer or the end-user shall be added in a readable manner on the Warranty Sticker.

In no event shall the Purchaser's compliance with the Consumer Protection Law and Regulations expand any of the Manufacturer's warranty obligations under this warranty, and the Purchaser shall be responsible for any warranty that it provides with respect to the Products which exceeds or is different from this warranty.

This warranty shall not be modified, varied or extended, and the Manufacturer does not authorize any person to act on its behalf in the modification, variation or extension of this warranty. This warranty shall apply to the Product only. All products, accessories or attachments of others used in conjunction with the Product, including batteries, shall be covered solely by their own warranty, if any. The Manufacturer shall not be liable for any damage or loss whatsoever, whether directly, indirectly, incidentally, consequentially or otherwise, caused by the malfunction of the Product due to products, accessories, or attachments of others, including batteries, used in conjunction with the Products. This Warranty is exclusive to the original Purchaser and is not assignable.

This Warranty is in addition to and does not affect your legal rights. Any provision in this warranty which is contrary to the Law in the state or country where the Product is supplied shall not apply.

Governing Law:

This disclaimer of warranties and limited warranty are governed by the domestic laws of Israel.

Warning

The user must follow the Manufacturer's installation and operational instructions including testing the Product and its whole system at least once a week and to take all necessary precautions for his/her safety and the protection of his/her property.

* In case of a conflict, contradiction or interpretation between the English version of the warranty and other versions, the English version shall prevail.

	<p>W.E.E.E. Product Recycling Declaration For information regarding the recycling of this product you must contact the company from which you originally purchased it. If you are discarding this product and not returning it for repair then you must ensure that it is returned as identified by your supplier. This product is not to be thrown away with everyday waste. Directive 2002/96/EC Waste Electrical and Electronic Equipment.</p>
---	--

© 2020 Johnson Controls. All rights reserved. JOHNSON CONTROLS, TYCO and VISONIC are trademarks of Johnson Controls.

email: info@visonic.com

Website: www.visonic.com

VISONIC LTD. 2020 MP-843/XHM2 D-307788 (Rev. 0, 05/20)



D-307788