

# Global EMC Inc. Labs EMC & RF Test Report

As per

**RSS 247: 2015**

**&**

**FCC Part 15 Subpart C: 2016**

**Unlicensed Intentional Radiators**

on the

## MCT-370 SMA



Min Xie  
Project Engineer  
11 Gordon Collins Dr,  
Gormley, ON, L0H 1G0 Canada  
Ph: (905) 883-8189

Testing produced for



See Appendix A for full customer & EUT details.



Client	<b>Visonic Ltd</b>	
Product	<b>MCT-370 SMA</b>	
Standard(s)	RSS 247:2015 / FCC Part 15 Subpart C 15:2016	

## Table of Contents

Table of Contents .....	2
Report Scope .....	3
Summary .....	4
Test Results Summary .....	5
Justifications, Descriptions, or Deviations.....	6
Applicable Standards, Specifications and Methods.....	7
Sample calculation(s).....	8
Document Revision Status.....	8
Definitions and Acronyms .....	9
Testing Facility .....	10
Calibrations and Accreditations.....	10
Testing Environmental Conditions and Dates .....	11
Detailed Test Results Section .....	12
6dB Bandwidth of Digitally Modulated Systems – 15.247 .....	13
Maximum Peak Envelope Conducted Power - DM.....	20
Antenna Spurious Conducted Emissions (-20 dBc Requirement) – 15.247.....	26
Radiated Emissions – 15.247.....	30
Power Spectral Density – 15.247 DM .....	57
RF Exposure.....	60
Appendix A – EUT Summary.....	62
Appendix B – EUT and Test Setup Photographs.....	66

Client	<b>Visonic Ltd</b>	
Product	<b>MCT-370 SMA</b>	
Standard(s)	RSS 247:2015 / FCC Part 15 Subpart C 15:2016	

## Report Scope

This report addresses the EMC verification testing and test results of MCT-370 SMA herein referred to as EUT (Equipment Under Test) performed at Global EMC, Gormley.

The EUT was tested for compliance against the following standards:

RSS 247:2015  
FCC Part 15 Subpart C 15.247:2016

Test procedures, results, justifications, and engineering considerations, if any, follow later in this report.

The results contained in this report relate only to the item(s) tested.

This report does not imply product endorsement by A2LA or any other accreditation agency, any government, or Global EMC .

Opinions/interpretations expressed in this report, if any, are outside the scope of Global EMC 's accreditation. Any opinions expressed do not necessarily reflect the opinions of Global EMC , unless otherwise stated.

Client	<b>Visonic Ltd</b>	
Product	<b>MCT-370 SMA</b>	
Standard(s)	RSS 247:2015 / FCC Part 15 Subpart C 15:2016	

## Summary

The results contained in this report relate only to the item(s) tested.

EUT FCC Certification #, FCC ID:	WP3MCT370SMA5
EUT Industry Canada Certification #, IC:	1467C-MCT370SMA
EUT Passed all tests performed.	Yes (see test results summary)
Tests conducted by	Min Xie

Client	<b>Visonic Ltd</b>	
Product	<b>MCT-370 SMA</b>	
Standard(s)	RSS 247:2015 / FCC Part 15 Subpart C 15:2016	

## Test Results Summary

Standard/Method	Description	Class/Limit	Result
FCC 15.203	Antenna Requirement	Unique	Pass See Justification
FCC 15.205 RSS-GEN (Table 6)	Restricted Bands for intentional operation	QuasiPeak Average	Pass
FCC 15.207 RSS-GEN (Table 3)	Power line conducted emissions	QuasiPeak Average	Pass
FCC 15.209 RSS-GEN (Table 4)	Spurious Radiated emissions	QuasiPeak Average	Pass
FCC 15.247(a)2 RSS-247 5.2 (1)	6 dB Bandwidth	> 500 kHz	Pass
FCC 15.247(b)2 RSS-247 5.4 (4)	Max output power	< 1 Watt	Pass
FCC 15.247(b)4 RSS-247 5.4 (4)	Antenna Gain	< 6 dBi	Pass See Justifications
FCC 15.247(d) RSS-247 5.5	Antenna conducted spurious	< 20 dBc	Pass
FCC 15.247(e) RSS-247 5.2 (2)	Spectral Density	< 8 dBm (3 kHz BW)	Pass
FCC 15.247(i) RSS-102	Maximum Permissible Exposure	> 20 cm separation.	Pass See justification and calculations
<b>Overall Result</b>			<b>PASS</b>

All tests were performed by Min Xie.

If the product as tested or otherwise complies with the specification, the EUT is deemed to comply with the requirement and is deemed a 'PASS' grade. If not 'FAIL' grade will be issued. Note that 'PASS' / 'FAIL' grade is independent of any measurement uncertainties. A 'PASS' / 'FAIL' grade within measurement uncertainty is marked with a '\*'.

Client	<b>Visonic Ltd</b>	
Product	<b>MCT-370 SMA</b>	
Standard(s)	RSS 247:2015 / FCC Part 15 Subpart C 15:2016	

### ***Justifications, Descriptions, or Deviations***

The following justifications for tests not performed or deviations from the above listed specifications apply:

For the Antenna requirement specified in FCC 15.203, the unit uses a permanently connected SMD antenna which is less than 6 dBi gain.

For the Restricted Bands of operation, the EUT is designed to only operate between 2400 – 2483.5 MHz band.

The EUT is not a hybrid system and FCC 15.247 (f) does not apply to it. However the 15.247 (d) requirement of power density were met and are detailed later in this test report.

For the scope of this test report the EUT was mounted in three orthogonal axes to maximize emissions. Worst case results are presented.

Power line conducted emissions were not applicable as the EUT is a battery operated device.

All tests were performed with new batteries.

Client	<b>Visonic Ltd</b>	
Product	<b>MCT-370 SMA</b>	
Standard(s)	RSS 247:2015 / FCC Part 15 Subpart C 15:2016	

## ***Applicable Standards, Specifications and Methods***

ANSI C63.4:2014	Methods of Measurement of Radio-Noise Emissions from Low-Voltage Electrical and Electronic Equipment in the Range of 9 kHz to 40 GHz
ANSI C63.10:2013	American national standard for testing unlicensed wireless devices
CFR 47 FCC 15	Code of Federal Regulations – Radio Frequency Devices
CISPR 22:2008	Information technology equipment – Radio disturbance characteristics – Limits and methods of measurement
FCC KDB 558074	FCC KDB 558074 Digital Transmission Systems, measurements and procedures
ICES-003:2012	Digital Apparatus - Spectrum Management and Telecommunications Policy Interference-Causing Equipment Standard
ISO 17025:2005	General Requirements for the competence of testing and calibration laboratories
RSS-GEN Issue 4	General Requirements and Information for the Certification of Radio Apparatus
RSS-247 Issue 1	Digital Transmission Systems (DTSs), Frequency Hopping Systems (FHSs) and Licence-Exempt Local Area Network (LE-LAN) Devices
RSS 102 Issue 5	Radio Frequency (RF) Exposure Compliance of Radiocommunication Apparatus (All Frequency Bands)

Client	<b>Visonic Ltd</b>	
Product	<b>MCT-370 SMA</b>	
Standard(s)	RSS 247:2015 / FCC Part 15 Subpart C 15:2016	

### ***Sample calculation(s)***

Margin = limit – (received signal + antenna factor + cable loss – pre-amp gain)

Margin = 50.5dBuV/m – (50dBuV + 10dB + 2.5dB – 20dB)

Margin = 8.5 dB

### ***Document Revision Status***

Revision 0 - Mar 10, 2016  
Initial release



Client	<b>Visonic Ltd</b>	
Product	<b>MCT-370 SMA</b>	
Standard(s)	RSS 247:2015 / FCC Part 15 Subpart C 15:2016	

## Definitions and Acronyms

The following definitions and acronyms are applicable in this report.  
See also ANSI C63.14.

**AE** – Auxillary Equipment.

**BW** – Bandwidth. Unless otherwise stated, this is refers to the 6 dB bandwidth.

**EMC** – Electro-Magnetic Compatibility

**EMI** – Electro-Magnetic Immunity

**EUT** – Equipment Under Test

**ITE** – Information Technology Equipment with a primary function(s) of entry, storage, display, retrieval, transmission, processing, switching, or control, of data.

**LISN** – Line impedance stabilization network

**NCR** – No Calibration Required

**RF** – Radio Frequency

Client	<b>Visonic Ltd</b>	
Product	<b>MCT-370 SMA</b>	
Standard(s)	RSS 247:2015 / FCC Part 15 Subpart C 15:2016	

## **Testing Facility**

Testing for EMC on the EUT was carried out at Global EMC near Toronto, Ontario, Canada. The testing lab consists of a 3m semi-anechoic chamber calibrated to be able to allow measurements on an EUT with a maximum width or length of up to 2m and height up to 3m. The chamber is equipped with a turn table that is capable of testing devices up to 3300lb in weight. This facility is capable of testing products that are rated for 120 Vac and 240Vac single phase, or 208 Vac 3 phase input. DC capability is also available. The chamber is equipped with an antenna mast that controls polarization and height from the control room adjoining the shielded chamber. Radiated emissions measurements are performed using a Bilog and Horn antenna where applicable. Conducted emissions, unless otherwise stated, are performed using a LISN.

### ***Calibrations and Accreditations***

The 3m semi-anechoic chamber is registered with Federal Communications Commission (FCC, 377448), Industry Canada (IC, 6844A-3) and VCCI (R-4023, G-506, T-1246, and C-4498). This semi-anechoic chamber complies with the requirements of EN55016-2-3:2006, section 7.5 and the site attenuation requirements of EN55016-1-4. This chamber was additionally calibrated for Normalized Site Attenuation (NSA) using test procedures outlined in ANSI C63.4 “Methods of Measurement of Radio-Noise Emissions from Low-Voltage Electrical and Electronic Equipment in the Range of 9 kHz to 40 GHz”. The chamber is lined with ferrite tiles and absorption cones to minimize any undesired reflections. The NSA data is kept on file at Global EMC . For radiated susceptibility testing, a 16 point field calibration has been performed on the chamber. The field uniformity data is kept on file at Global EMC . Global EMC Inc is accredited to ISO 17025 by A2LA with Testing Certificate #2955.02. The laboratories current scope of accreditation listing can be found as listed on the A2LA website. All measuring equipment is calibrated on an annual or bi-annual basis as listed for each respective test.

Client	<b>Visonic Ltd</b>	
Product	<b>MCT-370 SMA</b>	
Standard(s)	RSS 247:2015 / FCC Part 15 Subpart C 15:2016	

### ***Testing Environmental Conditions and Dates***

Following were the environmental conditions in the facility during time of testing –

<b>Date</b>	<b>Test</b>	<b>Init.</b>	<b>Temperature (°C)</b>	<b>Humidity (%)</b>	<b>Pressure (kPa)</b>
2016/03/01	Radiated emission	MX	20-24°C	39 - 50%	96 -102kPa
2016/03/01	Antenna conducted	MX	20-24°C	39 - 50%	96 -102kPa

Client	<b>Visonic Ltd</b>	
Product	<b>MCT-370 SMA</b>	
Standard(s)	RSS 247:2015 / FCC Part 15 Subpart C 15:2016	

## Detailed Test Results Section

Client	<b>Visonic Ltd</b>	
Product	<b>MCT-370 SMA</b>	
Standard(s)	RSS 247:2015 / FCC Part 15 Subpart C 15:2016	

## **6dB Bandwidth of Digitally Modulated Systems – 15.247**

### **Purpose**

The purpose of this test is to ensure that the bandwidth occupied exceeds a stated minimum. This helps ensure the utilization of the frequency allocation is sufficiently wide. This also helps prevent corruption of data by ensuring adequate data separation to distinguish the reception of the intended information.

### **Limits and Methods**

The Limit is as specified in FCC Part 15 and RSS 247.

Systems using digital modulation techniques may operate in the 902 - 928 MHz, 2400 - 2483.5 MHz and 5725 - 5850 MHz bands. The minimum 6 dB bandwidth shall be at least 500 kHz. This should be measured with a 100 kHz RBW and a 300 kHz VBW.

The method is given in Section 8.1 of FCC KDB 558074 and ANSI C63.10.

### **Results**

The EUT passed. The minimum measured 6 dB BW was 1617 kHz and the maximum 99% BW at full power setting is 2774 kHz.

Channel	Frequency (MHz)	6 dB Bandwidth (kHz)	99% Bandwidth (kHz)
Lo Channel (0xB)	2405	1617	2495
Mid Channel (0x13)	2445	1617	2714
Hi Channel (0x19)	2475	1637	2774
Hi Channel (0x1A)	2480	1617	3173

### **Graph(s)**

The graphs showed below shows the OBW during the operation of the device. This is measured by a max hold on the spectrum analyzer and the highest resolution bandwidth that is sufficiently low to exhibit the 6 dB bandwidth of a channel during operation of the EUT. This measurement is a peak measurement. Max hold is performed for a duration of not less than 1 minute.

Client	Visonic Ltd	
Product	MCT-370 SMA	
Standard(s)	RSS 247:2015 / FCC Part 15 Subpart C 15:2016	

6 dB Bandwidth  
Low Channel (Channel 0xB)

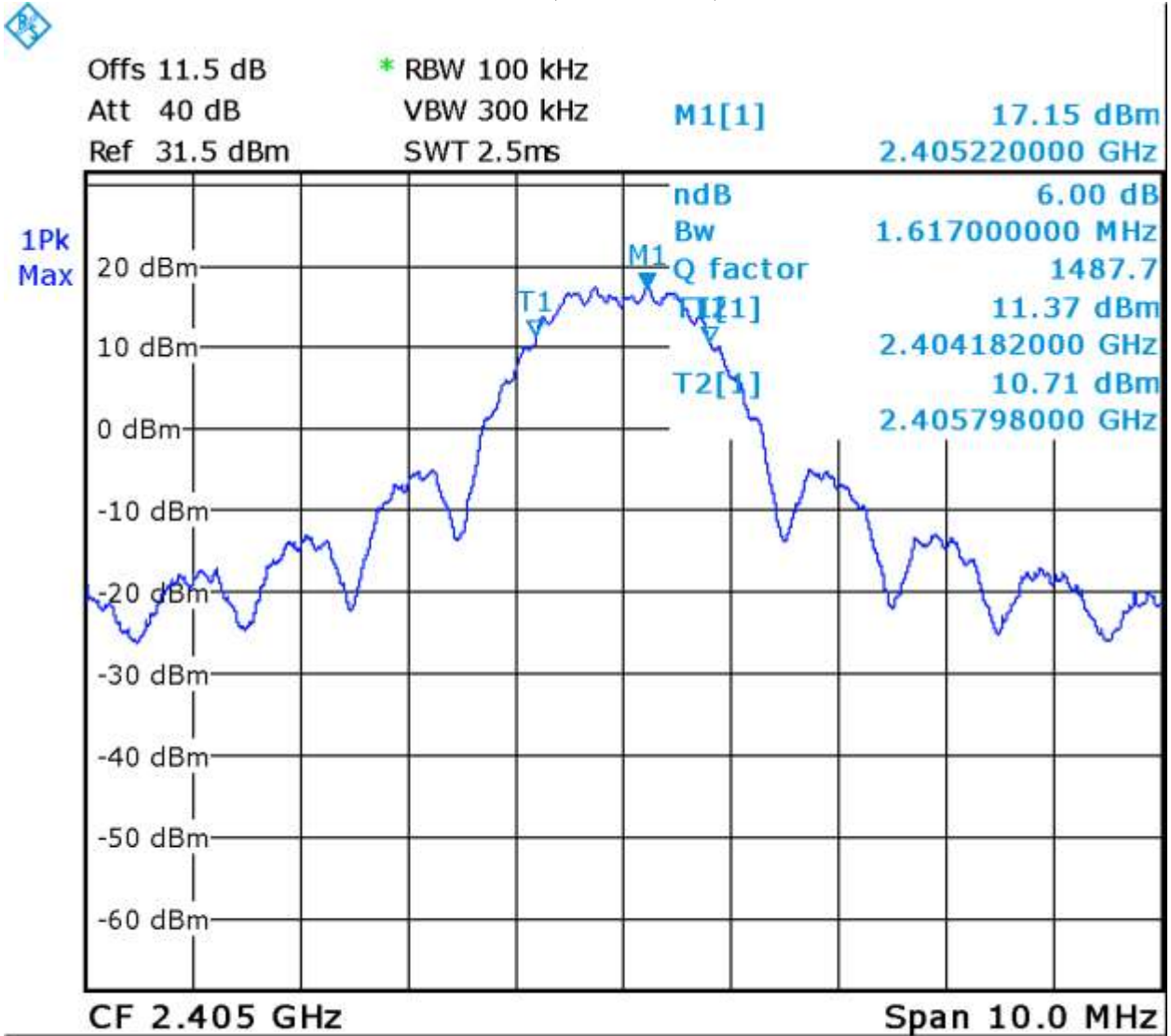

Date: 1.MAR.2016 15:13:55

Client	Visonic Ltd	
Product	MCT-370 SMA	
Standard(s)	RSS 247:2015 / FCC Part 15 Subpart C 15:2016	

6 dB Bandwidth  
Mid Channel (Channel 0x13)

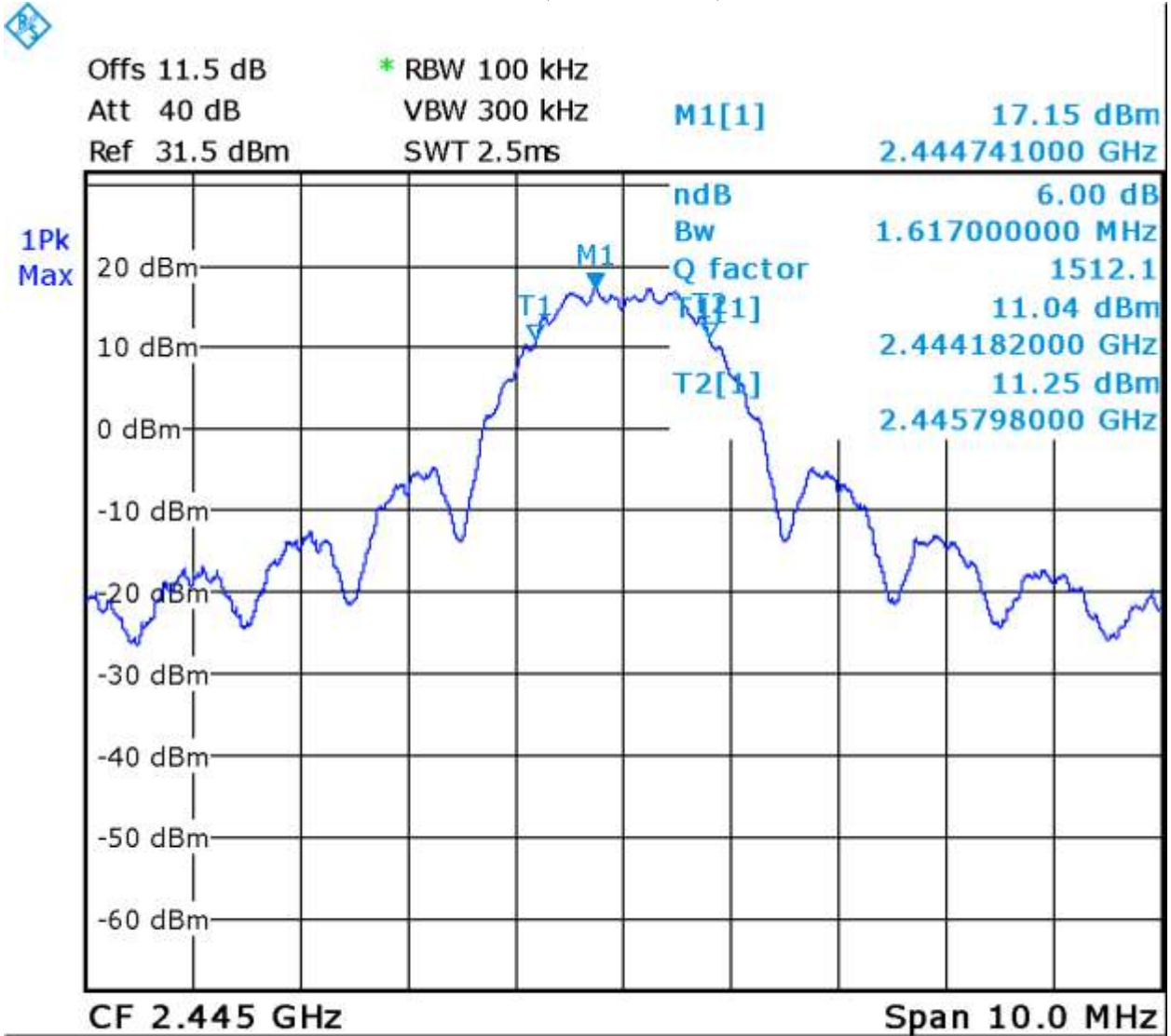

Date: 1.MAR.2016 14:53:42

Client	Visonic Ltd	
Product	MCT-370 SMA	
Standard(s)	RSS 247:2015 / FCC Part 15 Subpart C 15:2016	

6 dB Bandwidth  
High Channel (Channel 0x19)

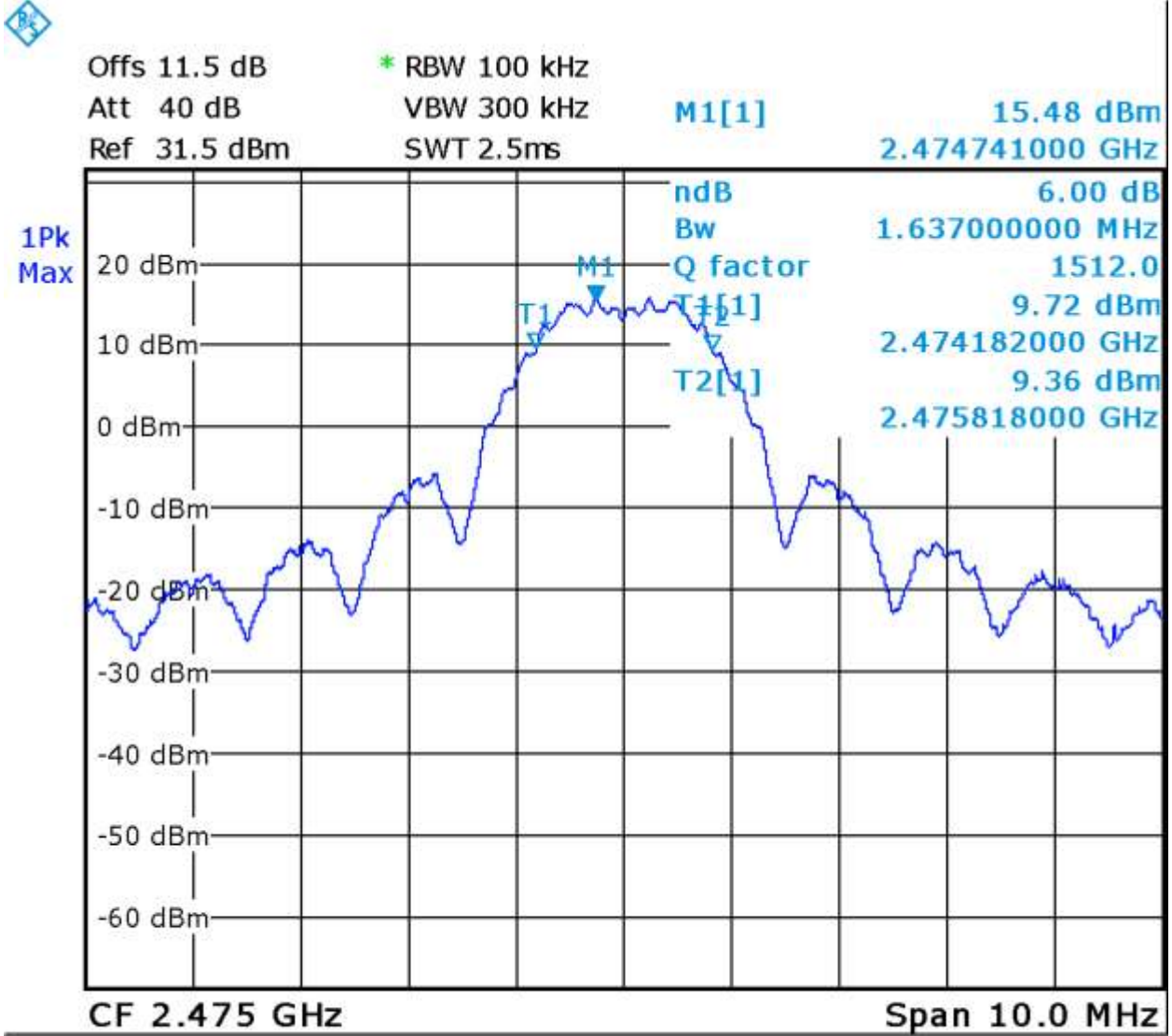

Date: 1.MAR.2016 15:27:53



Client	Visonic Ltd	
Product	MCT-370 SMA	
Standard(s)	RSS 247:2015 / FCC Part 15 Subpart C 15:2016	

6 dB Bandwidth  
High Channel (Channel 0x1A)

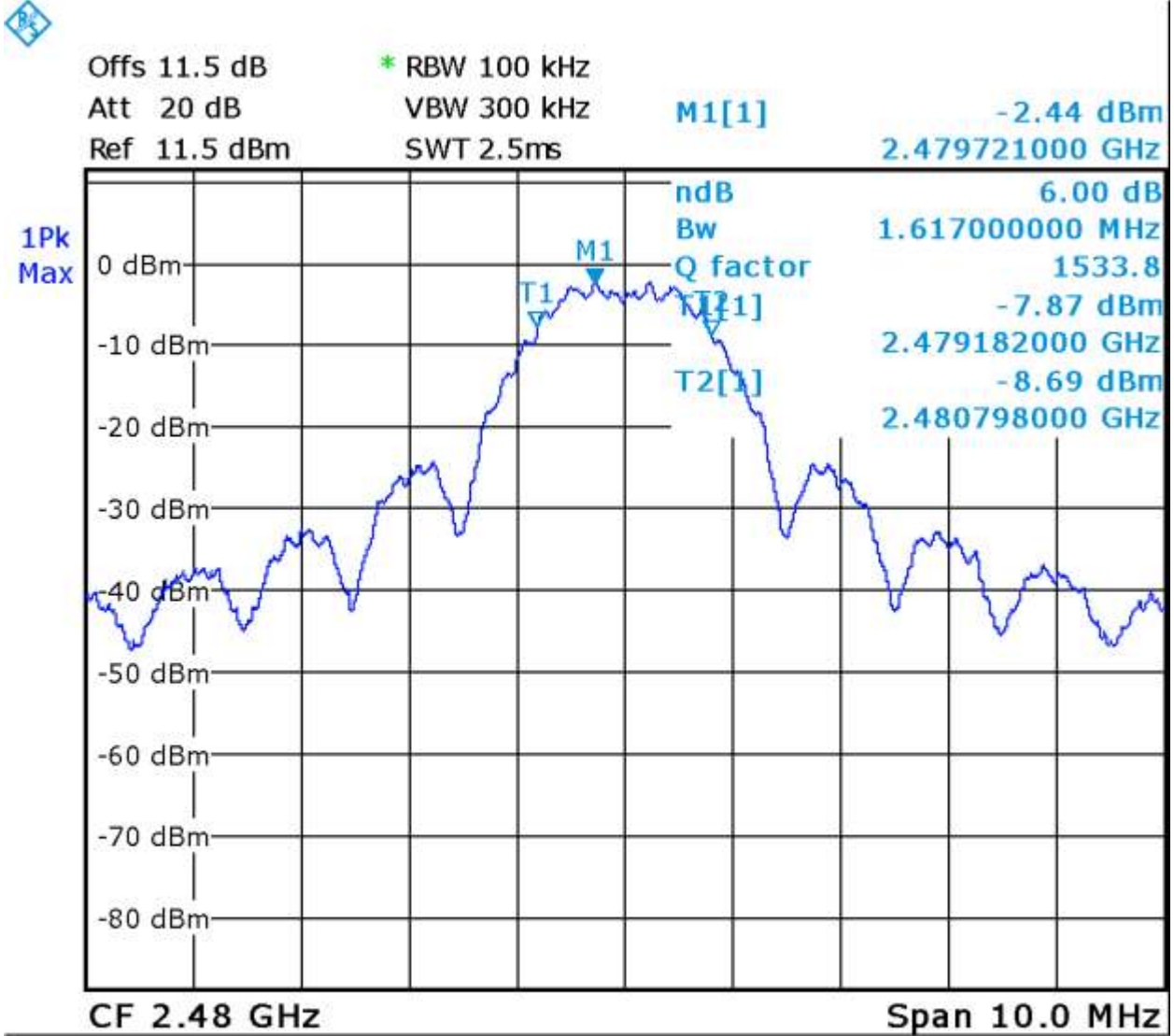

Date: 1.MAR.2016 15:40:55

Client	Visonic Ltd	
Product	MCT-370 SMA	
Standard(s)	RSS 247:2015 / FCC Part 15 Subpart C 15:2016	

99% BW – Mid Channel (0x13)

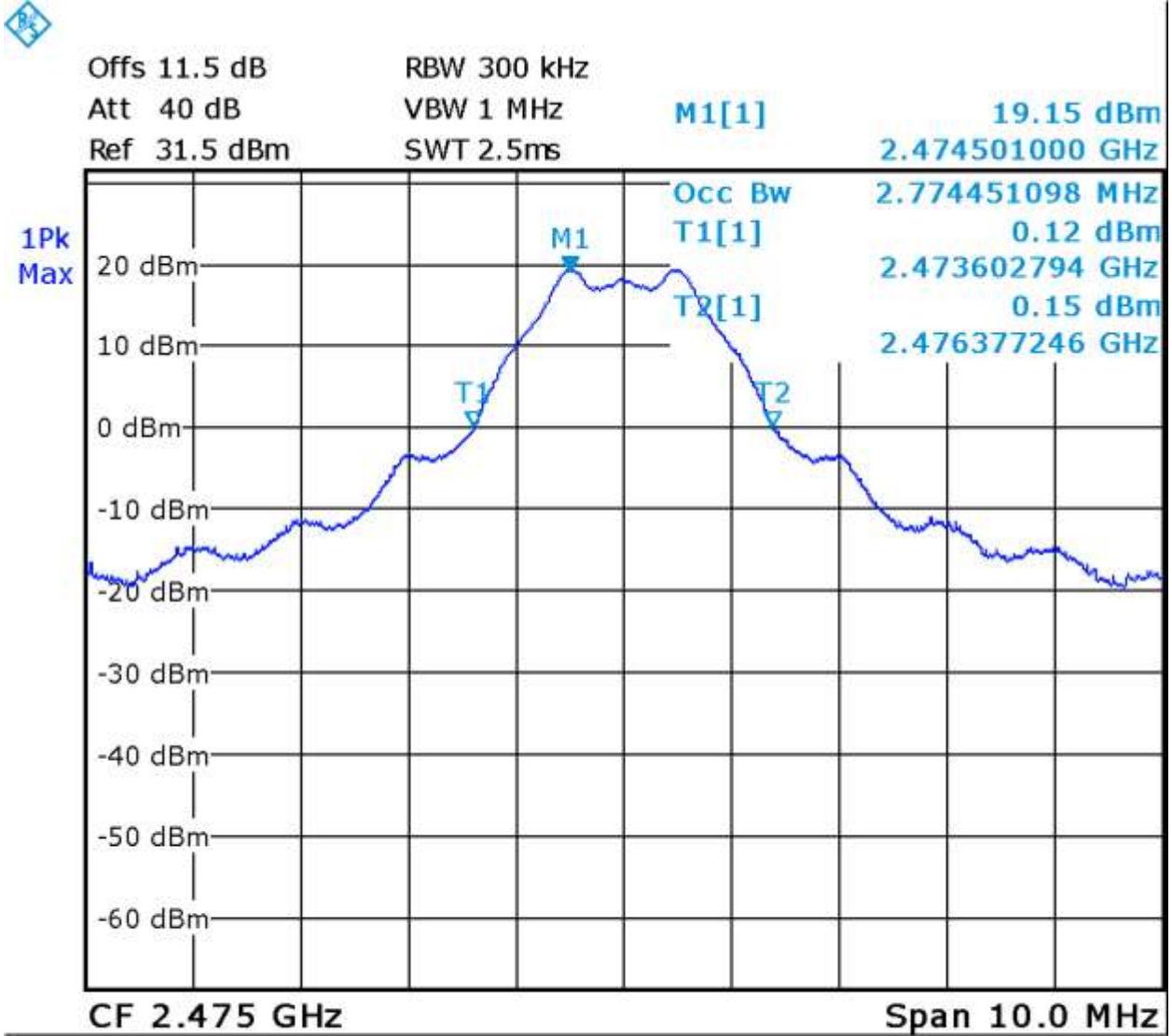

Date: 1.MAR.2016 15:26:31

Note: See 'Appendix B – EUT & Test Setup Photographs' for photos showing the test set-up.

Client	<b>Visonic Ltd</b>	
Product	<b>MCT-370 SMA</b>	
Standard(s)	RSS 247:2015 / FCC Part 15 Subpart C 15:2016	

## Test Equipment List

Equipment	Model No.	Manufacturer	Last calibration / Verification date	Next calibration/ Verification due date	Asset #
Spectrum Analyzer	ESL6	Rohde & Schwarz	Nov 25, 2015	Nov 25, 2017	GEMC 160
Attenuator 10 dB	8493B	Agilent	Feb 11, 2016	Feb 11, 2017	GEMC133

This report module is based on GEMC template "FCC – Power Line Conducted Emissions Class B\_Rev1"

Client	<b>Visonic Ltd</b>	
Product	<b>MCT-370 SMA</b>	
Standard(s)	RSS 247:2015 / FCC Part 15 Subpart C 15:2016	

## Maximum Peak Envelope Conducted Power - DM

### Purpose

The purpose of this test is to ensure that the maximum power conducted to the radiating element does not exceed the limits specified. This ensures that if the end-user replaces the antenna, that the maximum power does not exceed an amount which may create an excessive power level.

### Limits and Methods

The limits are defined in FCC Part 15.247(b) and RSS 247.

For systems using digital modulation in the 902-928 MHz, 2400-2483.5 MHz, and 5725-5850 MHz bands, the peak limit is 1 watt.

The method is given in Section 9.1.2 of FCC KDB 558074 and ANSI C63.10

### Results

The EUT passed. The peak power of the EUT was set to transmit at maximum power. Three Channels were measured. The following table show the peak power: The external attenuator and cable loss are accounted for as reference offset in the spectrum analyzer.

Channel	Frequency (MHz)	Peak Power (dBm)	Peak Power (mW)
Lo Channel (0xB)	2405	20.75	118.9
Mid Channel (0x13)	2445	20.12	102.8
Hi Channel (0x19)	2475	19.13	81.8
Hi Channel (0x1A)	2480	3.06	2.0

### Graphs

The plots shown below shows the peak power output of the device during the antenna conducted measurement during transmit operation of the EUT. The measurement RBW is  $\geq$  than the DTS bandwidth.

Client	Visonic Ltd	
Product	MCT-370 SMA	
Standard(s)	RSS 247:2015 / FCC Part 15 Subpart C 15:2016	

Peak Power  
Channel 0xB

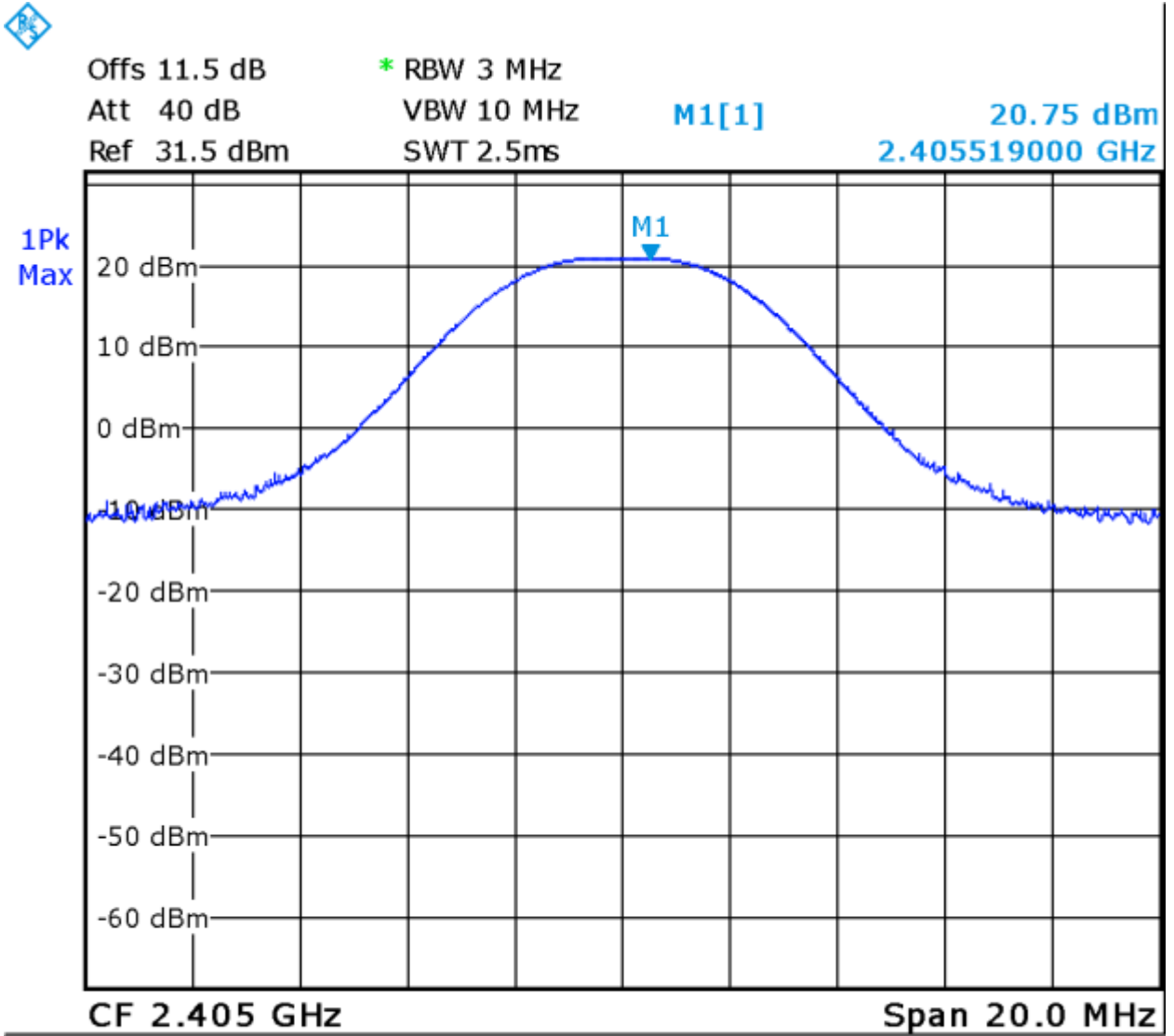

Date: 1.MAR.2016 15:07:02

Client	Visonic Ltd	
Product	MCT-370 SMA	
Standard(s)	RSS 247:2015 / FCC Part 15 Subpart C 15:2016	

Peak Power  
Channel 0x13



Offs 11.5 dB      \* RBW 3 MHz  
 Att 40 dB          VBW 10 MHz      M1[1]                      20.12 dBm  
 Ref 31.5 dBm      SWT 2.5ms                      2.444501000 GHz

1Pk  
Max

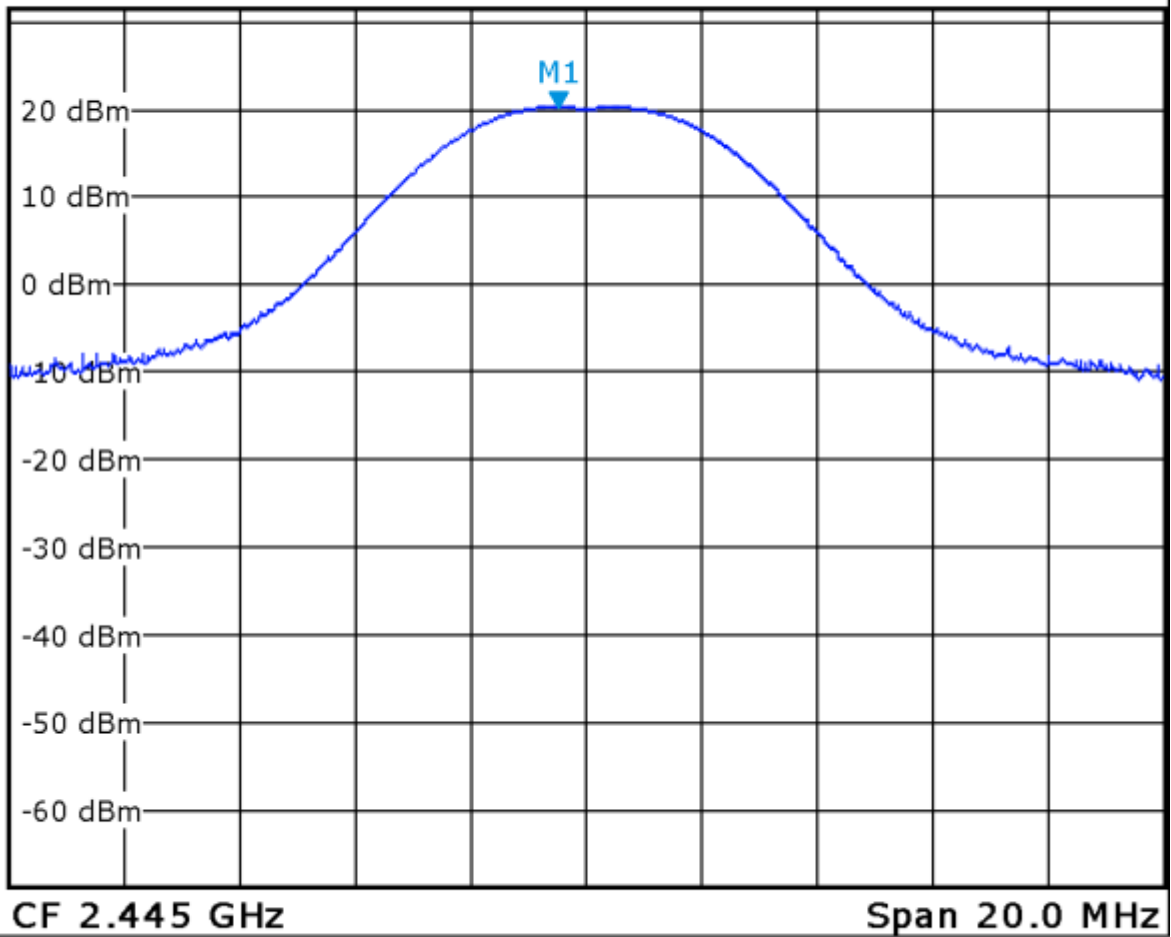

Date: 1.MAR.2016 15:01:15

Peak Power  
Channel 0x19

Client	Visonic Ltd	
Product	MCT-370 SMA	
Standard(s)	RSS 247:2015 / FCC Part 15 Subpart C 15:2016	



Offs 11.5 dB      \* RBW 3 MHz  
 Att 40 dB      VBW 10 MHz      M1[1]      19.13 dBm  
 Ref 31.5 dBm      SWT 2.5ms      2.475559000 GHz

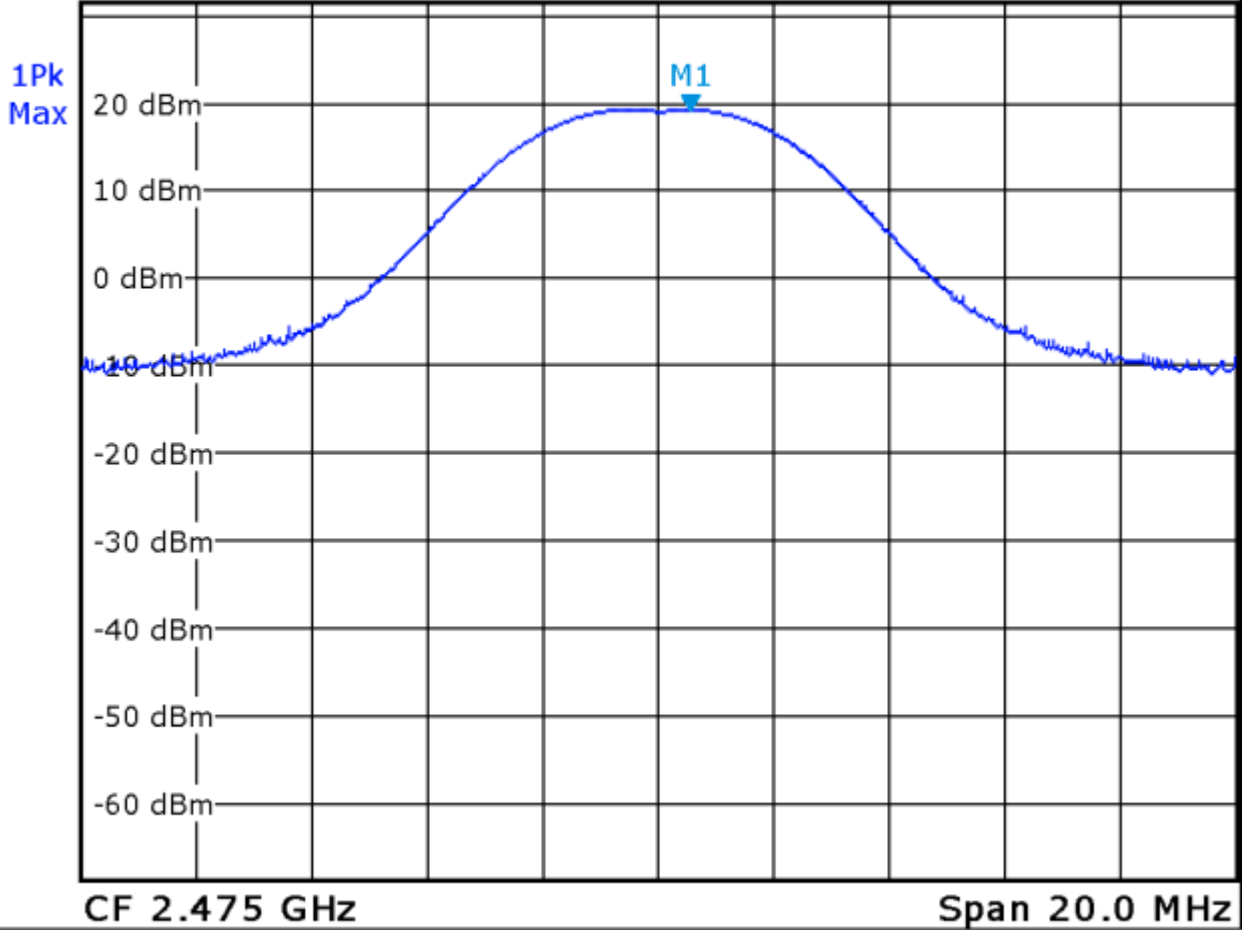

Date: 1.MAR.2016 15:32:07

Client	Visonic Ltd	
Product	MCT-370 SMA	
Standard(s)	RSS 247:2015 / FCC Part 15 Subpart C 15:2016	

Peak Power  
Channel 0x1A

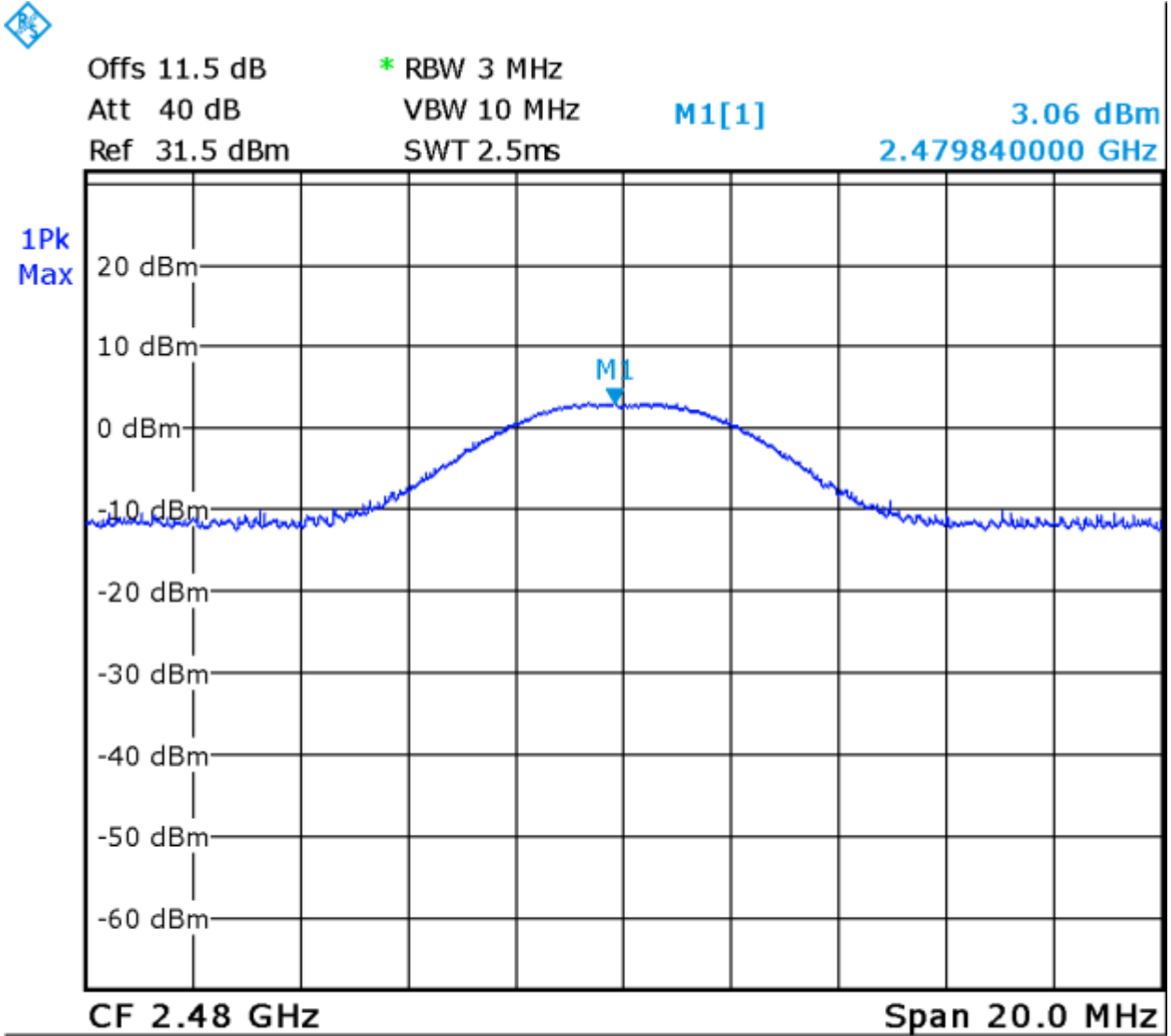

Date: 1.MAR.2016 15:34:12

Note: See 'Appendix B – EUT & Test Setup Photographs' for photos showing the test set-up.



Client	<b>Visonic Ltd</b>	
Product	<b>MCT-370 SMA</b>	
Standard(s)	RSS 247:2015 / FCC Part 15 Subpart C 15:2016	

### Test Equipment List

Equipment	Model No.	Manufacturer	Last calibration / Verification date	Next calibration/ Verification due date	Asset #
Spectrum Analyzer	ESL6	Rohde & Schwarz	Nov 25, 2015	Nov 25, 2017	GEMC 160
Attenuator 10 dB	8493B	Agilent	Feb-11, 2016	Feb-11, 2017	GEMC133

This report module is based on GEMC template "FCC – Power Line Conducted Emissions Class B\_Rev1"

Client	<b>Visonic Ltd</b>	
Product	<b>MCT-370 SMA</b>	
Standard(s)	RSS 247:2015 / FCC Part 15 Subpart C 15:2016	

## ***Antenna Spurious Conducted Emissions (-20 dBc Requirement) – 15.247***

### **Purpose**

The purpose of this test is to ensure that the maximum power conducted to the radiating element at frequencies outside of the authorized spectrum does not exceed the limits specified. This ensures that the only the intended signal is delivered to the radiating element.

### **Limits and Methods**

The limits are defined in 15.247(d). In any 100 kHz band, the peak spurious harmonics emissions must be at least 20 dB below the fundamental. Spurious Conducted emissions are to be evaluated up to the 10<sup>th</sup> harmonic. This -20 dBc requirement also applies at the ‘band edge’ or 2.4 GHz and 2.4835 GHz.

The method is given in Section 11 of FCC KDB 558074 and ANSI C63.10

### **Results**

The EUT passed the limits. Low, middle and high channels were measured. The worst case was presented as a graph for the spectrum. The -20 dBc requirement is shown for the lower band edge at 2.4 GHz in the low band. The -20 dBc requirement is also shown for the higher band edge at 2.4835 GHz in the high band.

Client	Visonic Ltd	
Product	MCT-370 SMA	
Standard(s)	RSS 247:2015 / FCC Part 15 Subpart C 15:2016	

### Graph(s)

The graphs shown below shows the peak power output of the device during the antenna conducted measurement during transmit operation of the EUT.

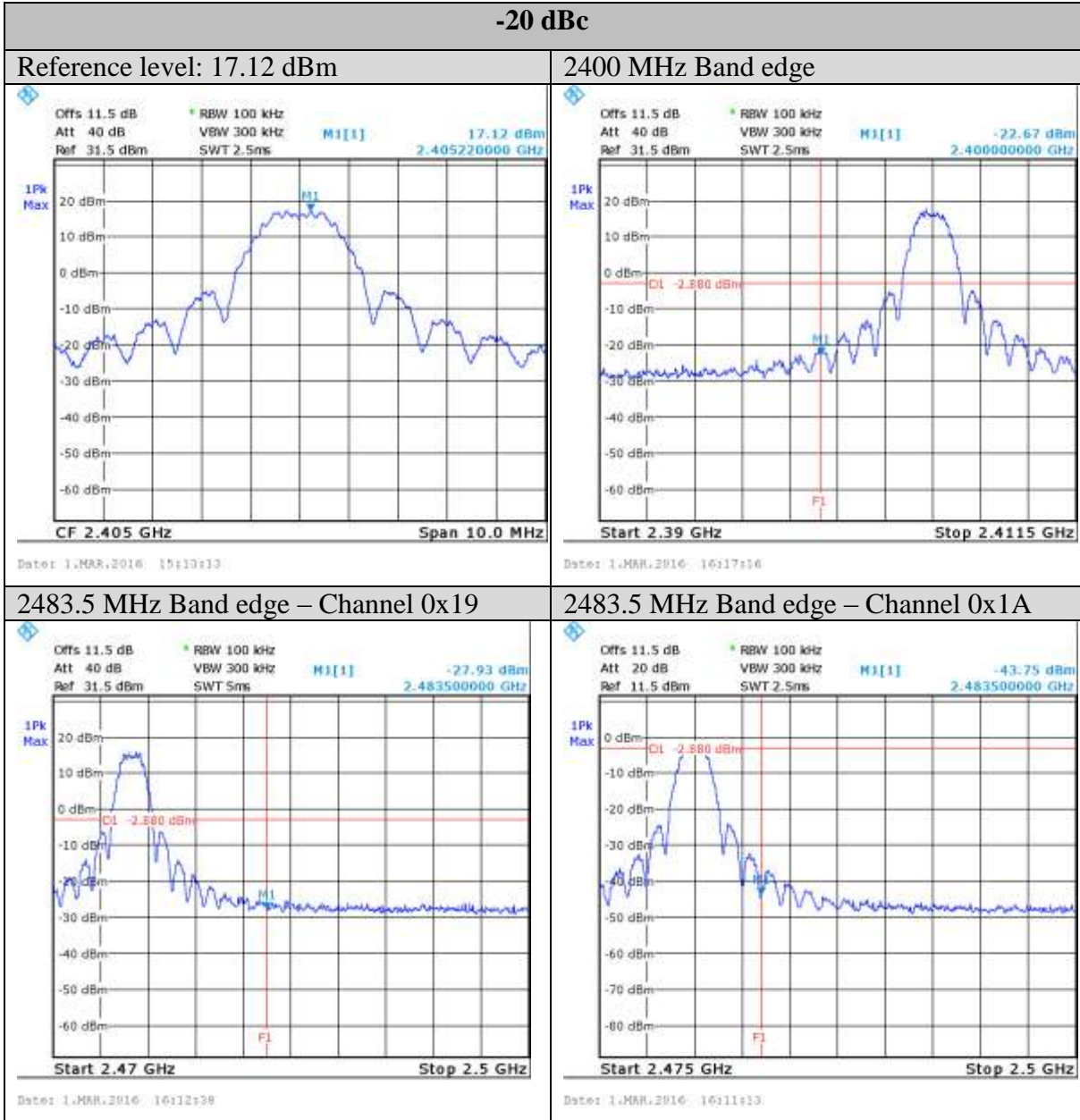

Client	Visonic Ltd	
Product	MCT-370 SMA	
Standard(s)	RSS 247:2015 / FCC Part 15 Subpart C 15:2016	

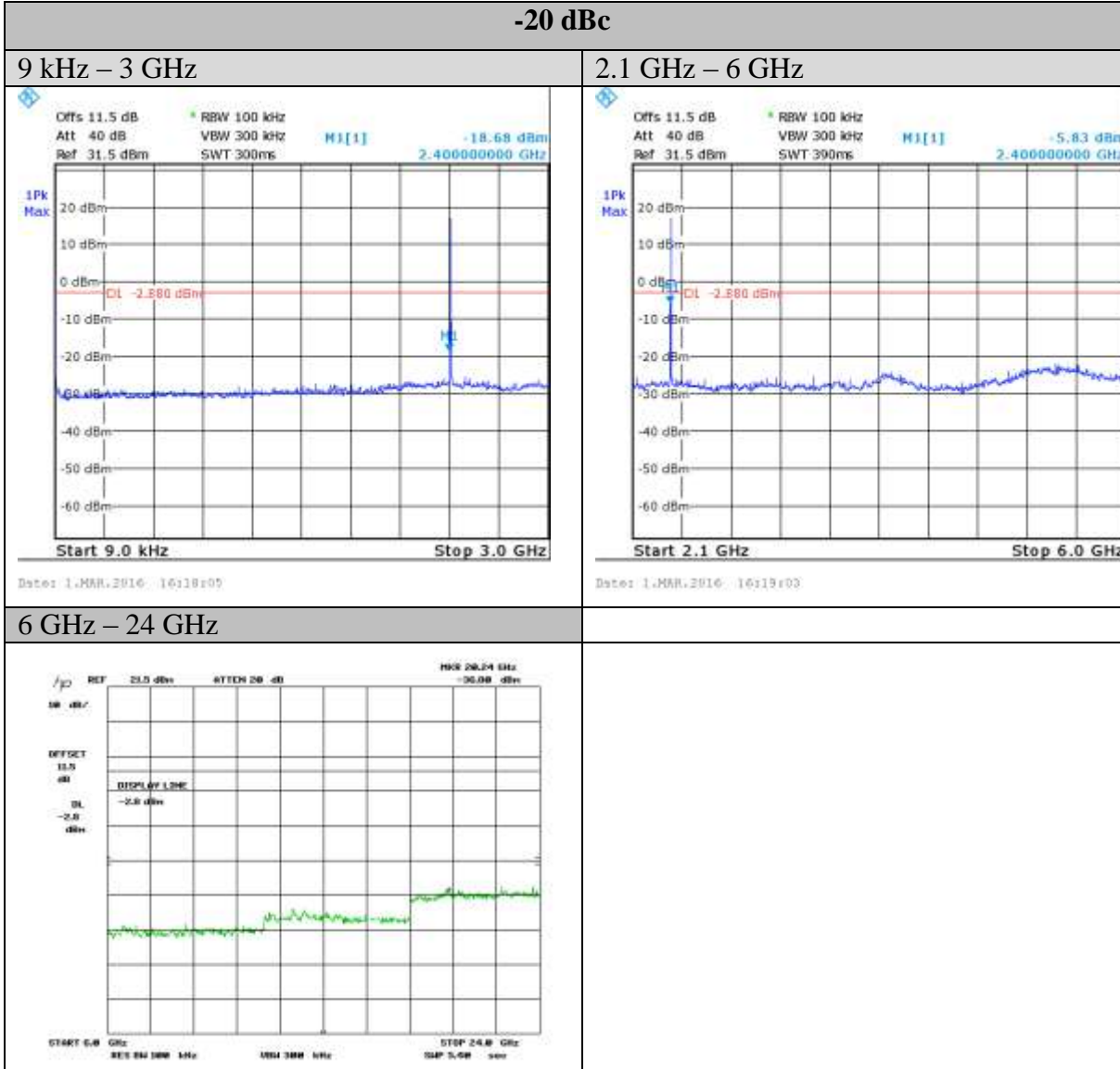

Note: See ‘Appendix B – EUT & Test Setup Photographs’ for photos showing the test set-up.

Client	<b>Visonic Ltd</b>	
Product	<b>MCT-370 SMA</b>	
Standard(s)	RSS 247:2015 / FCC Part 15 Subpart C 15:2016	

### Test Equipment List

Equipment	Model No.	Manufacturer	Last calibration / Verification date	Next calibration/ Verification due date	Asset #
Spectrum Analyzer	8566B	HP	Nov 27, 2015	Nov 27, 2017	GEMC 190
Quasi Peak Adapter	85650A	HP	Nov 27, 2015	Nov 27, 2017	GEMC 191
Spectrum Analyzer	ESL6	Rohde & Schwarz	Nov 25, 2015	Nov 25, 2017	GEMC 160
Attenuator 10 dB	8493B	Agilent	Feb-11, 2016	Feb-11, 2017	GEMC133

This report module is based on GEMC template "FCC – Power Line Conducted Emissions Class B\_Rev1"

Client	<b>Visonic Ltd</b>	
Product	<b>MCT-370 SMA</b>	
Standard(s)	RSS 247:2015 / FCC Part 15 Subpart C 15:2016	

## ***Radiated Emissions – 15.247***

### **Purpose**

The purpose of this test is to ensure that the RF energy unintentionally emitted from the EUT does not exceed the limits listed below as defined in the applicable test standard, as measured from a receiving antenna. This helps protect broadcast radio services such as television, FM radio, pagers, cellular telephones, emergency services, and so on, from unwanted interference.

### **Limit and Method**

The method is given in Section 12.1 of FCC KDB 558074 and ANSI C 63.10  
The limits are as defined in FCC Part 15, Section 15.209:

The limits, as defined in 15.247(d) for unintentional radiated emissions apply for those emissions that fall in the restricted bands, as defined in Section 15.205(a). These emissions must comply with the radiated emission limits specified in Section 15.209(a).

All unintentional emissions must also meet the ‘Spurious Conducted Emissions’ requirements of -20 dBc or greater. See also ‘Spurious Conducted Emissions’ for further details.

0.009 MHz – 0.490 MHz, 2400/F (kHz) uV/m at 300 m<sup>1</sup>  
0.490 MHz – 1.705 MHz, 24000/F (kHz) uV/m at 30 m<sup>1</sup>  
1.705 MHz – 30 MHz, 30 uV/m at 30 m<sup>1</sup>  
30 MHz – 88 MHz, 100 uV/m (40.0 dBuV/m<sup>1</sup>) at 3 m  
88 MHz – 216 MHz, 150 uV/m (43.5 dBuV/m<sup>1</sup>) at 3 m  
216 MHz – 960 MHz, 200 uV/m (46.0 dBuV/m<sup>1</sup>) at 3 m  
Above 960 MHz, 500 uV/m (54.0 dBuV/m<sup>1</sup>) at 3 m  
Above 1000 MHz, 500 uV/m (54 dBuV/m<sup>2</sup>) at 3m  
Above 1000 MHz, 500 uV/m (74 dBuV/m<sup>3</sup>) at 3m

<sup>1</sup>Limit is with Quasi Peak detector with bandwidths as defined in CISPR-16-1-1

<sup>2</sup>Limit is with 1 MHz measurement bandwidth and using an Average detector

<sup>3</sup>Limit is with 1 MHz measurement bandwidth and using a Peak detector

Client	<b>Visonic Ltd</b>	
Product	<b>MCT-370 SMA</b>	
Standard(s)	RSS 247:2015 / FCC Part 15 Subpart C 15:2016	

### Typical Radiated Emissions Setup

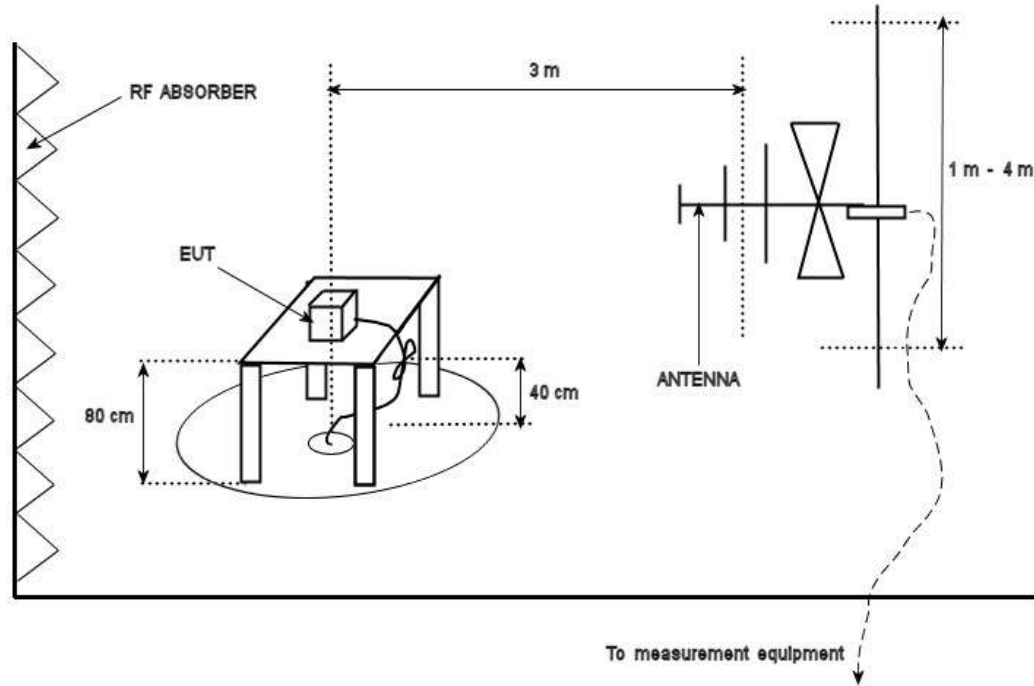

### Measurement Uncertainty

The expanded measurement uncertainty is calculated in accordance with CISPR 16-4-2 and is +/-4.4 dB with a 'k=2' coverage factor and a 95% confidence level.

### Preliminary Graphs

Note the graphs shown below are for graphical illustration only. For final measurements with the appropriate detector, please refer to the final measurement table where applicable. The graph shown below is a maximized peak measurement graph, measured with a resolution bandwidth greater than the final required detector and over a full 0-360 rotation. This peaking process is done as a worst case measurement. This process enables the detection of frequencies of concern for final measurement, and provides considerable time savings.

In accordance with FCC Part 15, Subpart A, Section 15.33, the device was scanned to the 10<sup>th</sup> harmonic (a minimum of a 24.835 GHz).

Devices scanned may be scanned at alternate test distances, and in accordance with FCC Part 15, Subpart A, Section 15.31, an extrapolation factor of 20 dB/decade was used above

Client	<b>Visonic Ltd</b>	
Product	<b>MCT-370 SMA</b>	
Standard(s)	RSS 247:2015 / FCC Part 15 Subpart C 15:2016	

30 MHz and 40 dB/decade below 30 MHz. For example for 1 meter measurements, an extrapolation factor 9.5 dB from 20 Log (1m / 3m) is applied.

Low, middle and high channels were measured, each in three orthogonal axes were checked; however the worst case graphs are presented.

Band edge measure graphs were shown for illustrations purpose. See final measurement section for all measurements.

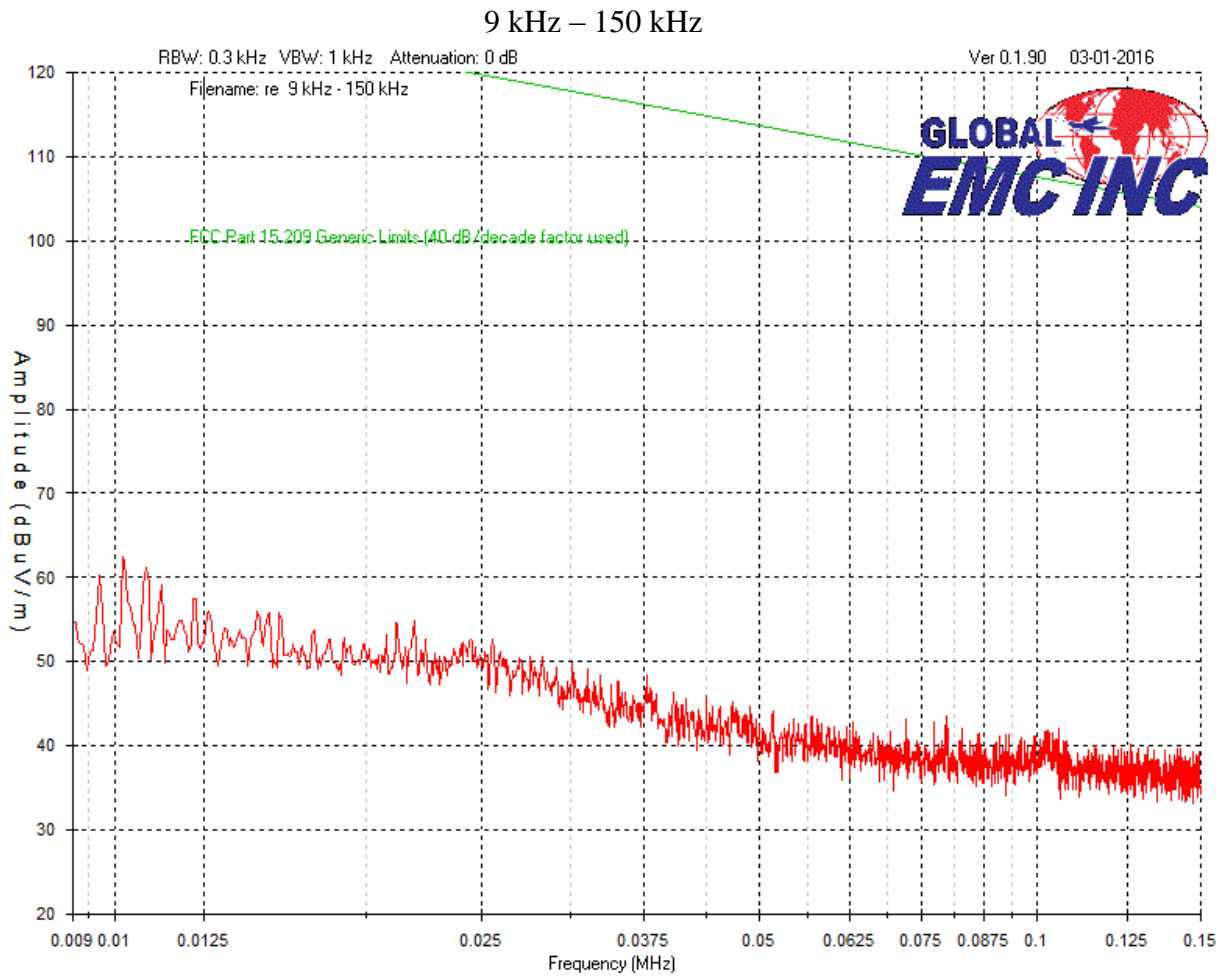



Client	<b>Visonic Ltd</b>	
Product	<b>MCT-370 SMA</b>	
Standard(s)	<b>RSS 247:2015 / FCC Part 15 Subpart C 15:2016</b>	

150 kHz – 30 MHz

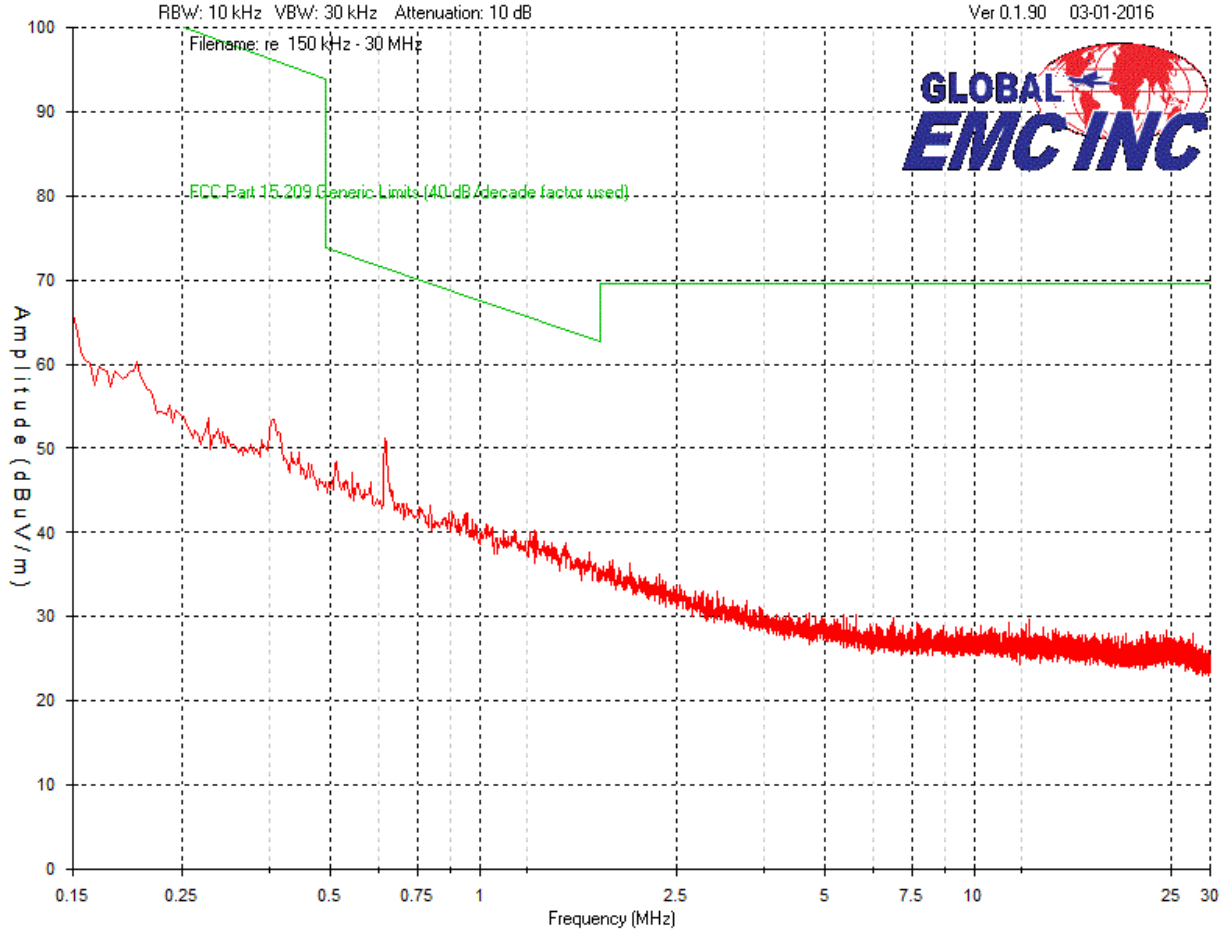

Client	<b>Visonic Ltd</b>	
Product	<b>MCT-370 SMA</b>	
Standard(s)	<b>RSS 247:2015 / FCC Part 15 Subpart C 15:2016</b>	

**Mid Channel - 30 MHz – 1 GHz  
Vertical – Peak Emission Graph**

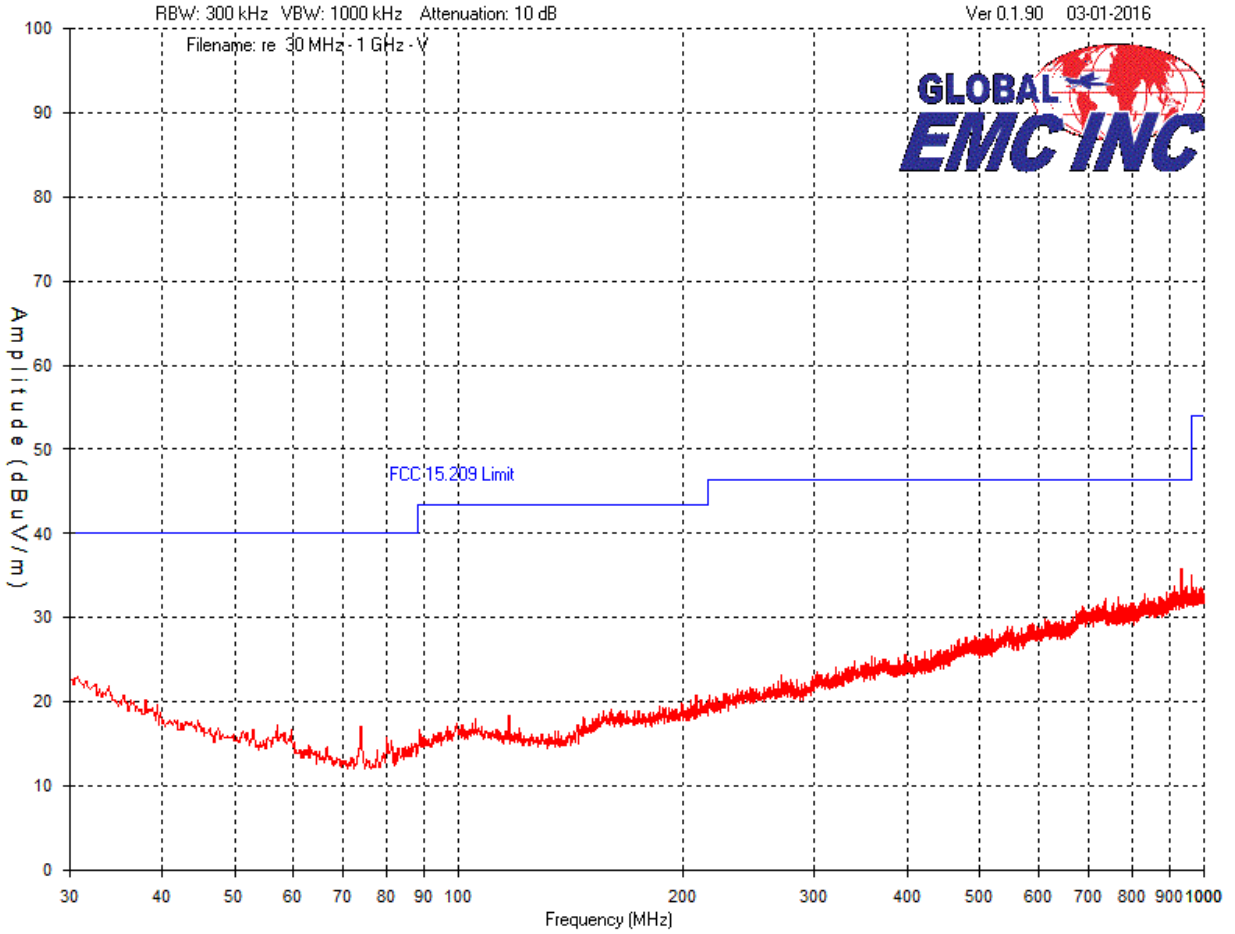

Client	<b>Visonic Ltd</b>	
Product	<b>MCT-370 SMA</b>	
Standard(s)	<b>RSS 247:2015 / FCC Part 15 Subpart C 15:2016</b>	

Mid Channel – 30 MHz – 1 GHz  
Horizontal - Peak Emission Graph

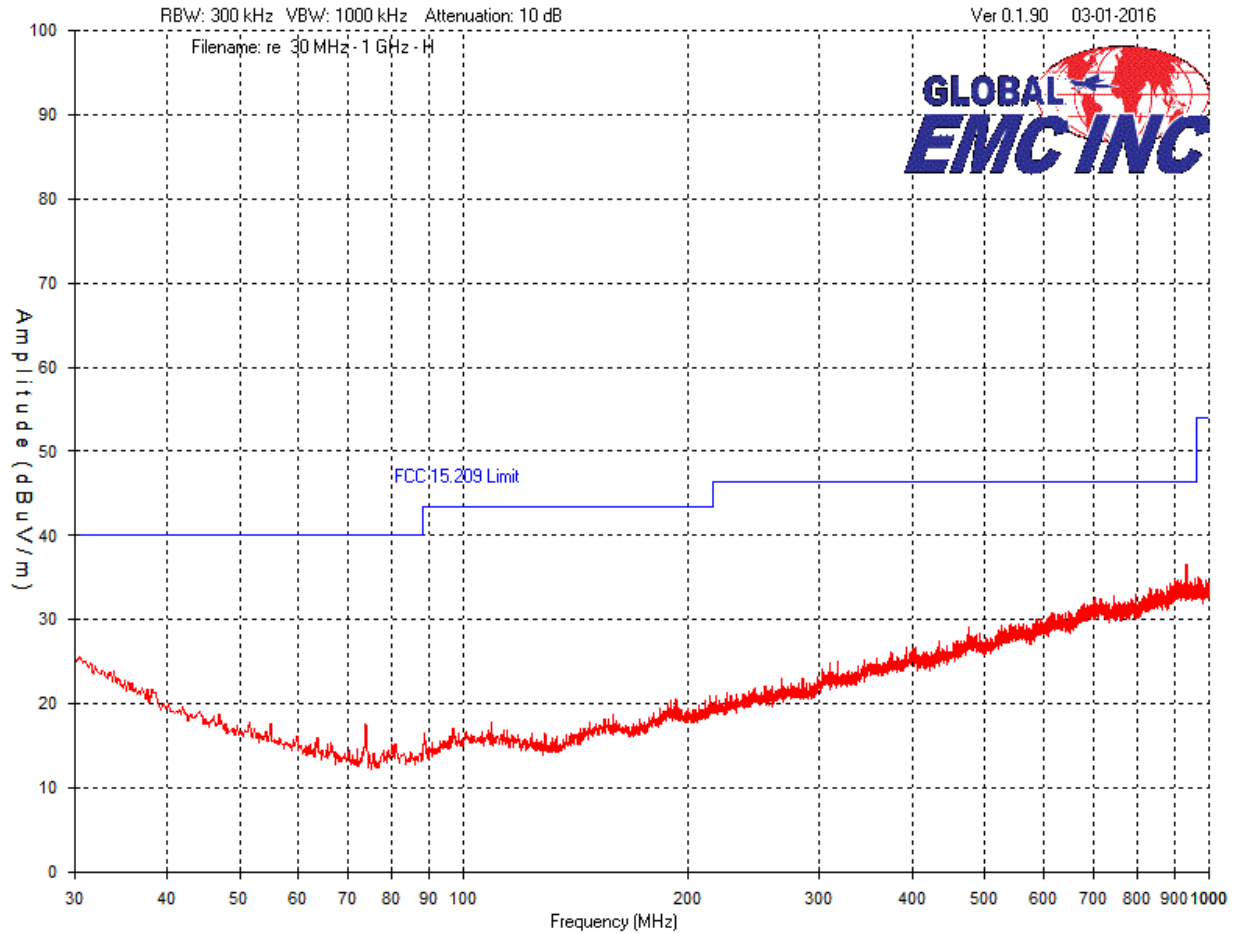

Client	<b>Visonic Ltd</b>	
Product	<b>MCT-370 SMA</b>	
Standard(s)	<b>RSS 247:2015 / FCC Part 15 Subpart C 15:2016</b>	

Mid Channel – 1 GHz – 2 GHz  
Vertical - Peak Emission Graph

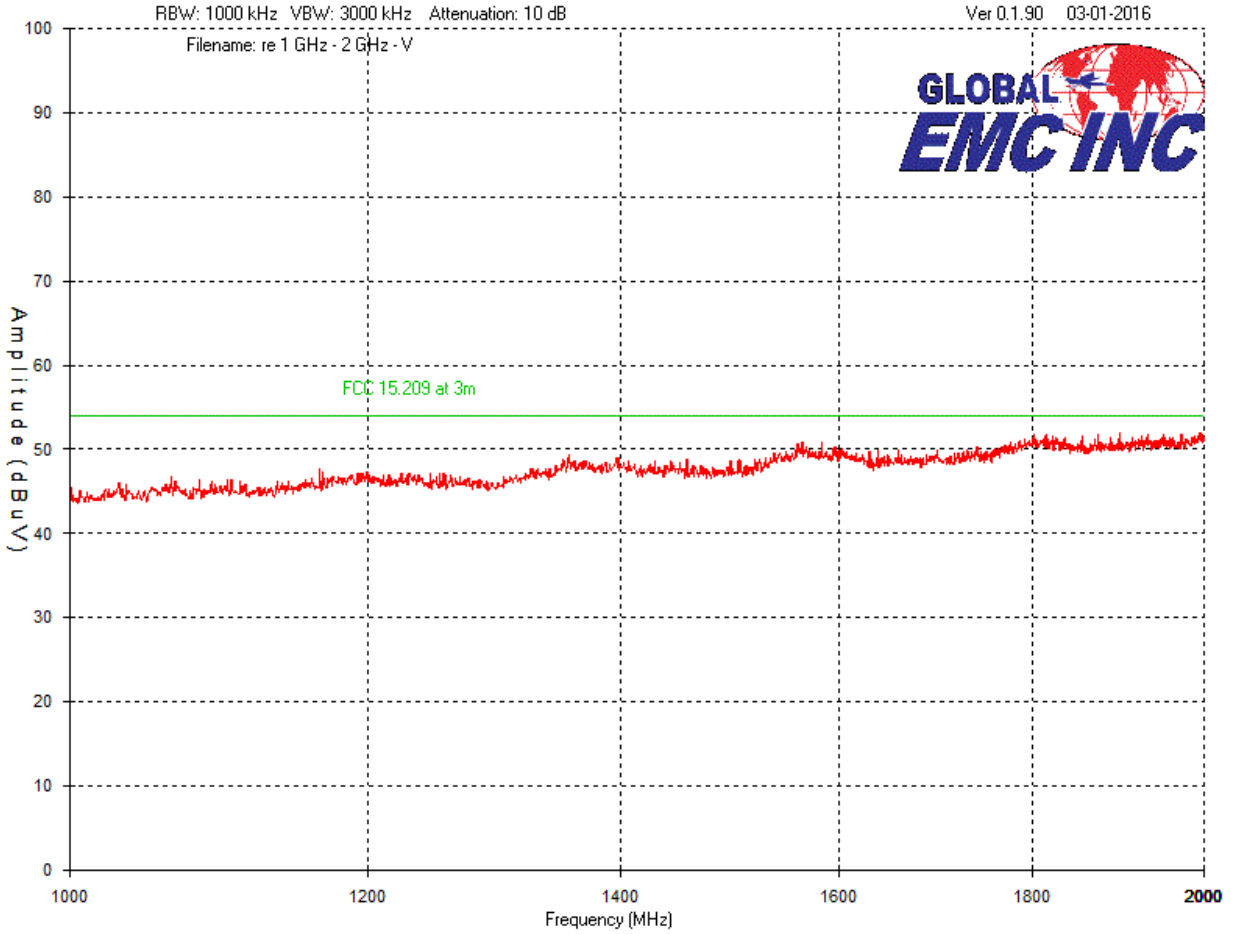

Client	<b>Visonic Ltd</b>	
Product	<b>MCT-370 SMA</b>	
Standard(s)	<b>RSS 247:2015 / FCC Part 15 Subpart C 15:2016</b>	

Mid Channel – 1 GHz – 2 GHz  
Horizontal - Peak Emission Graph

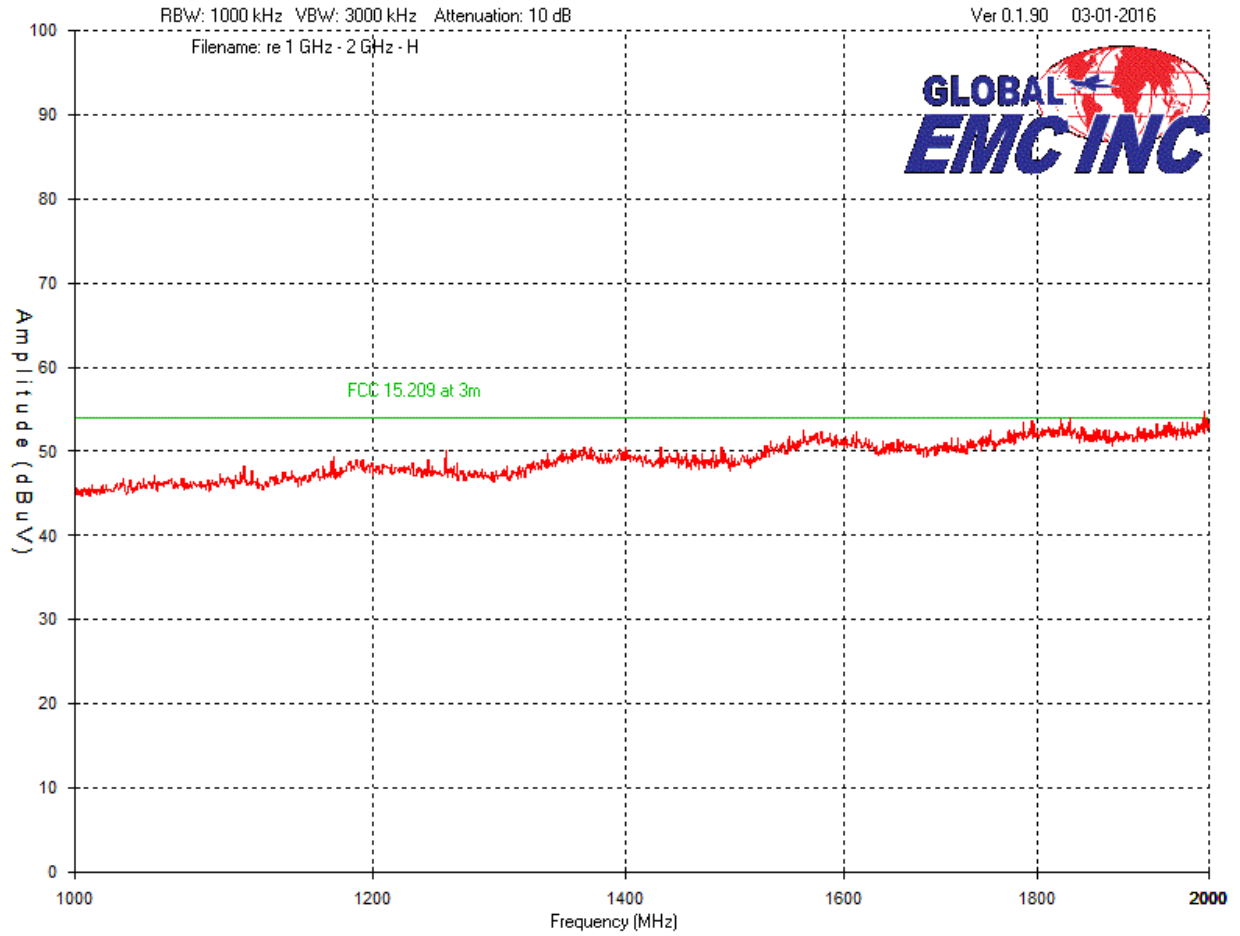

Client	<b>Visonic Ltd</b>	
Product	<b>MCT-370 SMA</b>	
Standard(s)	<b>RSS 247:2015 / FCC Part 15 Subpart C 15:2016</b>	

Mid Channel – 2 GHz – 4 GHz  
Vertical - Peak Emission Graph

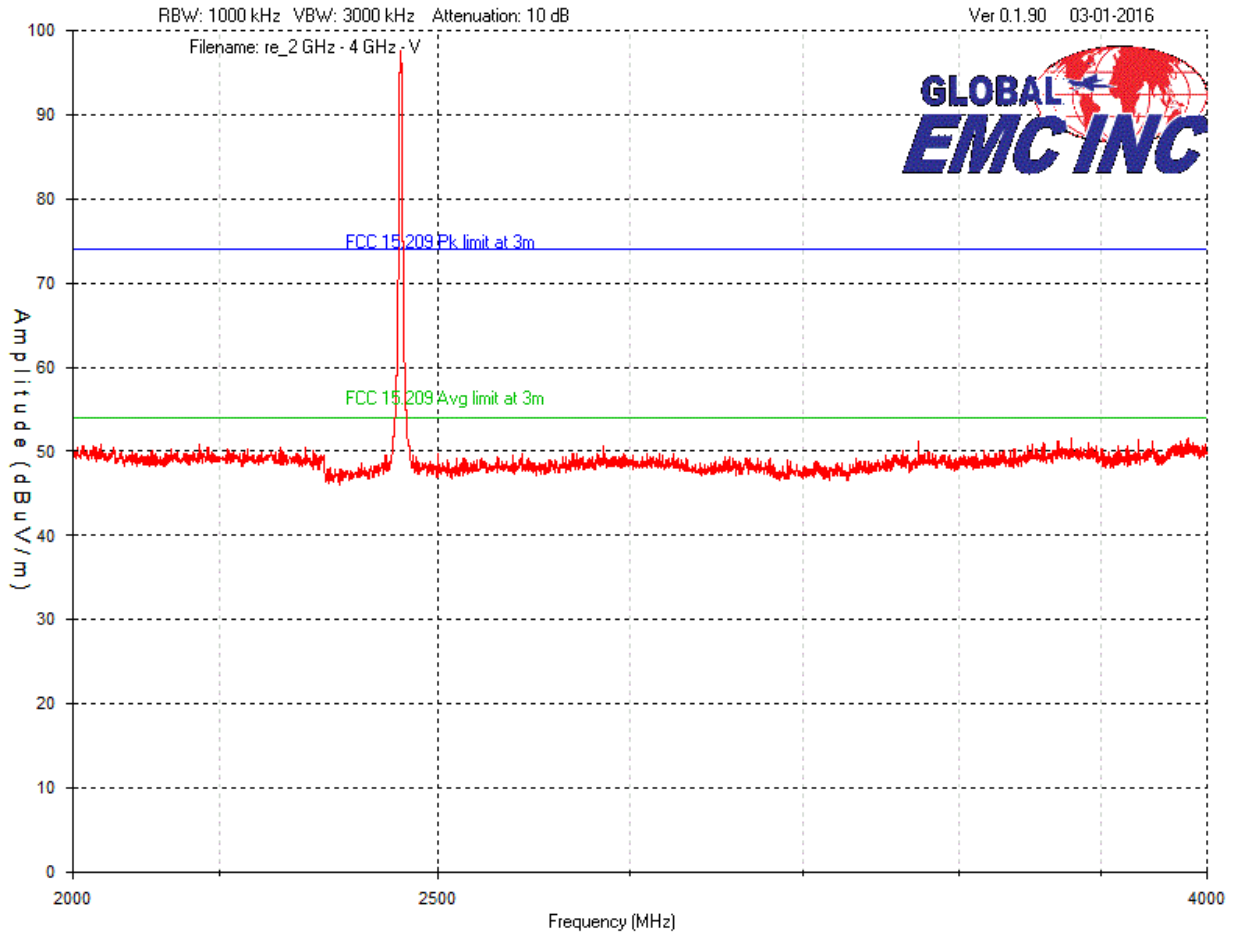

Note: See Final Measurements and Results section starting on page 54 for measurements.

Client	<b>Visonic Ltd</b>	
Product	<b>MCT-370 SMA</b>	
Standard(s)	<b>RSS 247:2015 / FCC Part 15 Subpart C 15:2016</b>	

Mid Channel – 2 GHz – 4 GHz  
Horizontal - Peak Emission Graph

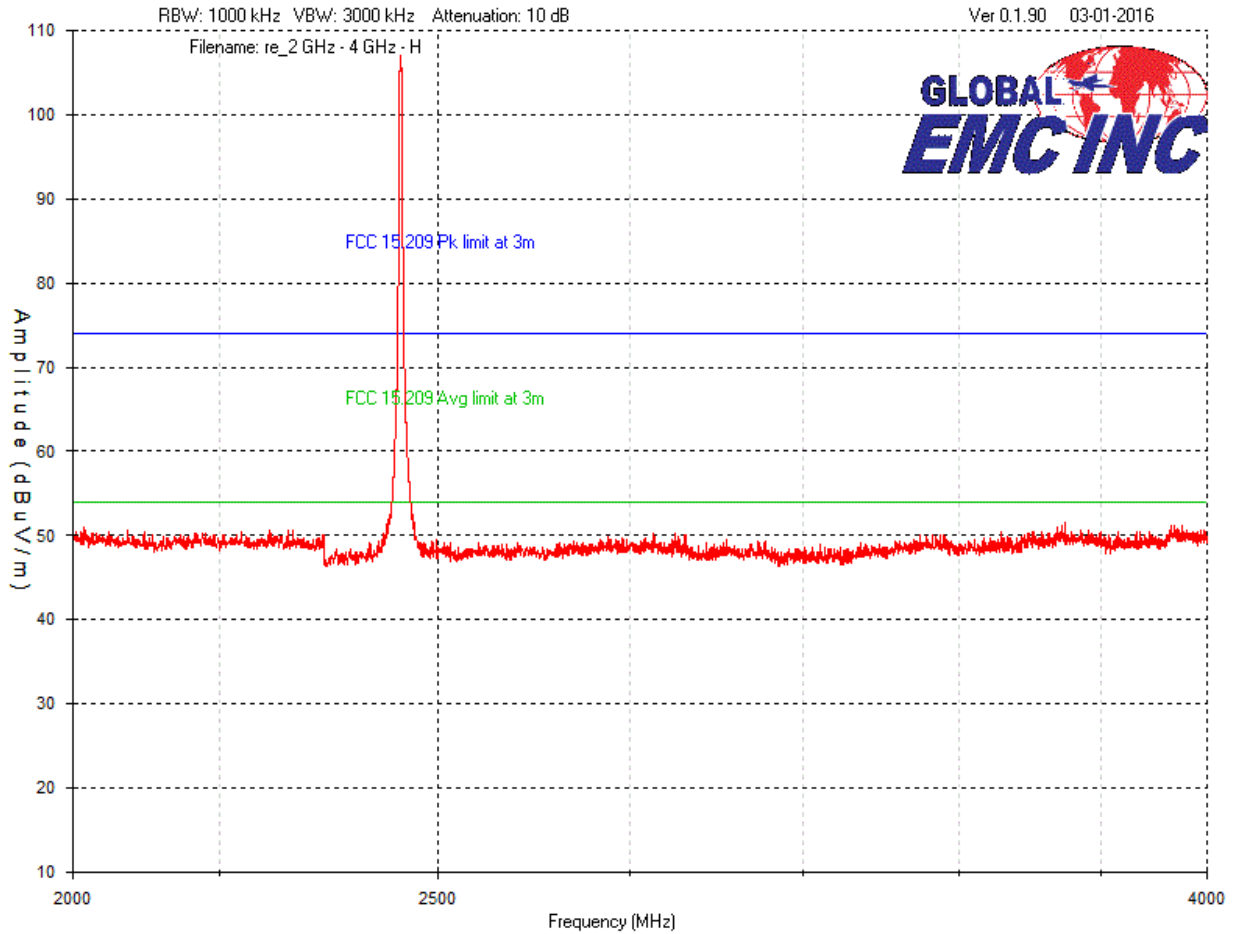

Note: See Final Measurements and Results section starting on page 54 for measurements.

Client	<b>Visonic Ltd</b>	
Product	<b>MCT-370 SMA</b>	
Standard(s)	RSS 247:2015 / FCC Part 15 Subpart C 15:2016	

Mid Channel – 4 GHz – 10GHz  
Vertical - Peak Emission Graph

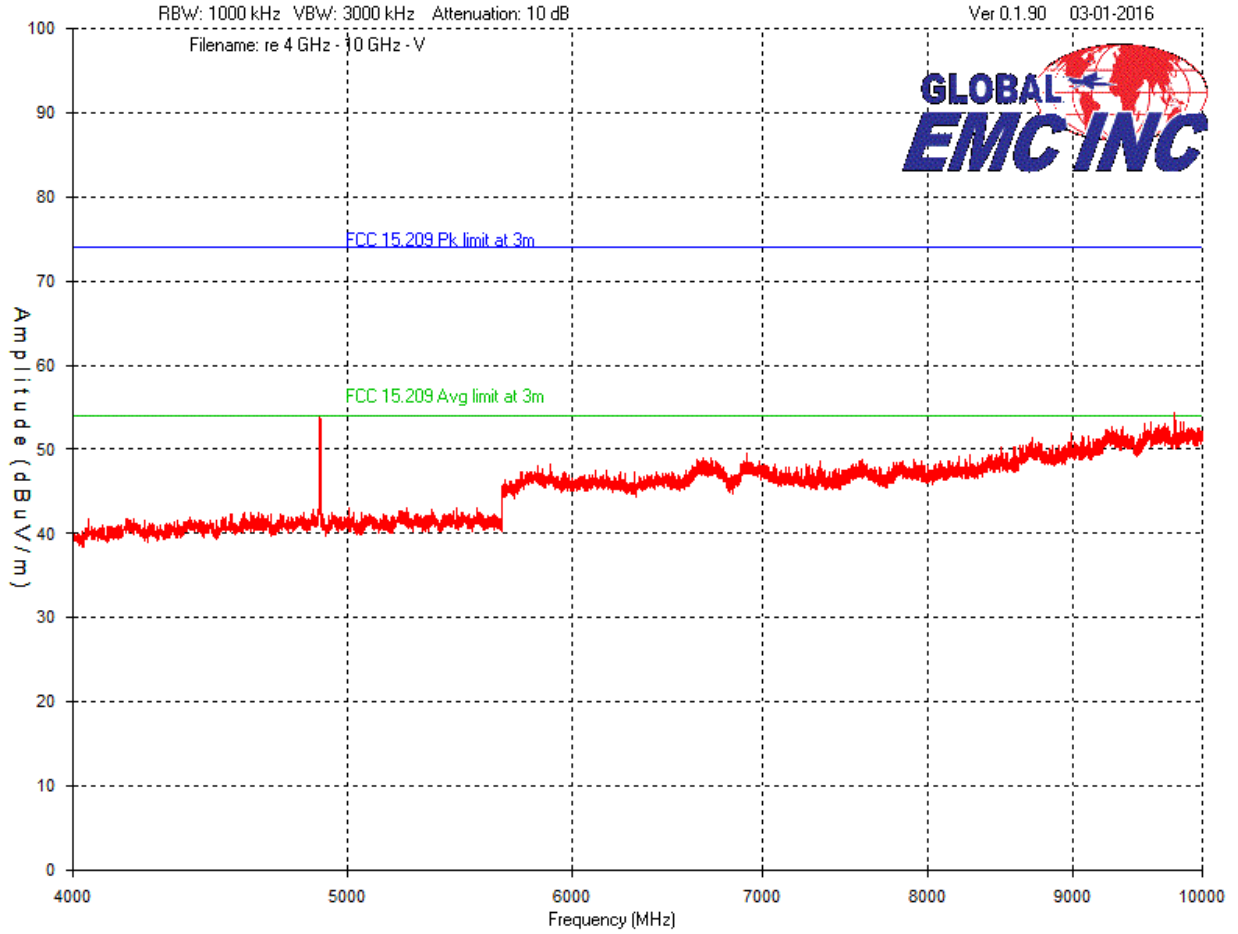

Note: See Final Measurements and Results section starting on page 54 for measurements.



Client	<b>Visonic Ltd</b>	
Product	<b>MCT-370 SMA</b>	
Standard(s)	<b>RSS 247:2015 / FCC Part 15 Subpart C 15:2016</b>	

Mid Channel – 4 GHz – 10 GHz  
Vertical - Peak Emission Graph

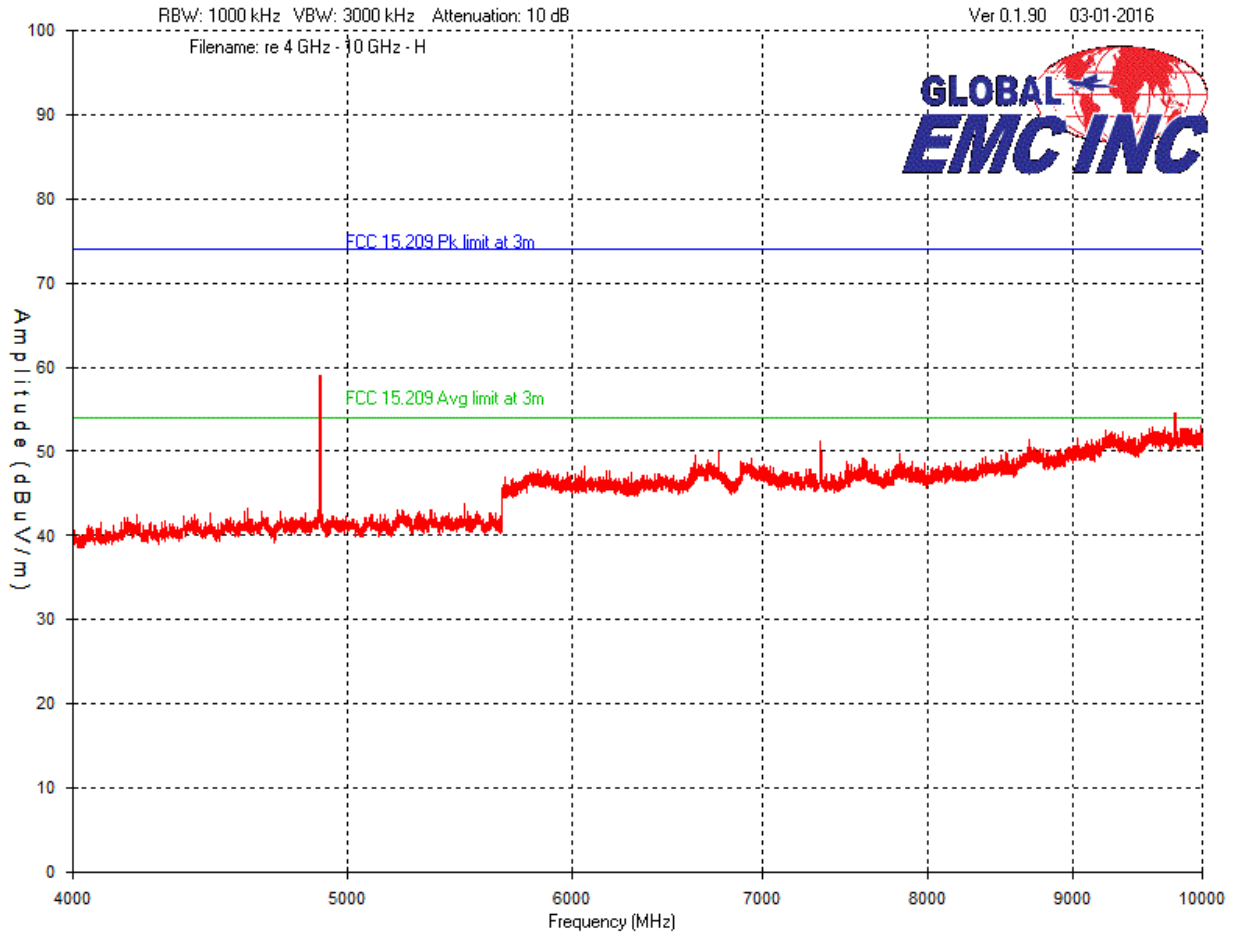

Note: See Final Measurements and Results section starting on page 54 for measurements.

Client	<b>Visonic Ltd</b>	
Product	<b>MCT-370 SMA</b>	
Standard(s)	<b>RSS 247:2015 / FCC Part 15 Subpart C 15:2016</b>	

Mid Channel – 10 GHz – 18 GHz  
Vertical - Peak Emission Graph

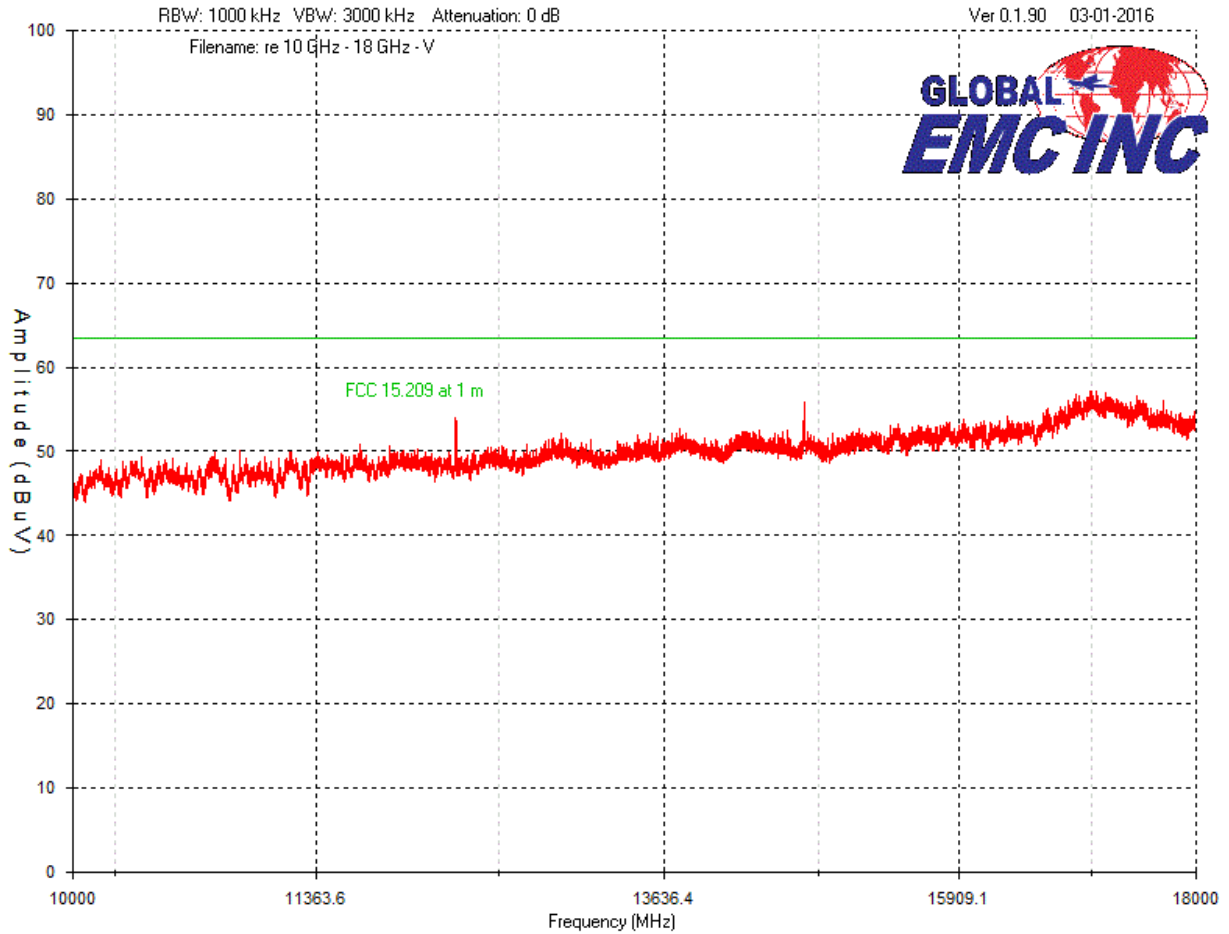

Note: See Final Measurements and Results section starting on page 54 for measurements.

Client	<b>Visonic Ltd</b>	
Product	<b>MCT-370 SMA</b>	
Standard(s)	<b>RSS 247:2015 / FCC Part 15 Subpart C 15:2016</b>	

Mid Channel – 10 GHz – 18 GHz  
Horizontal - Peak Emission Graph

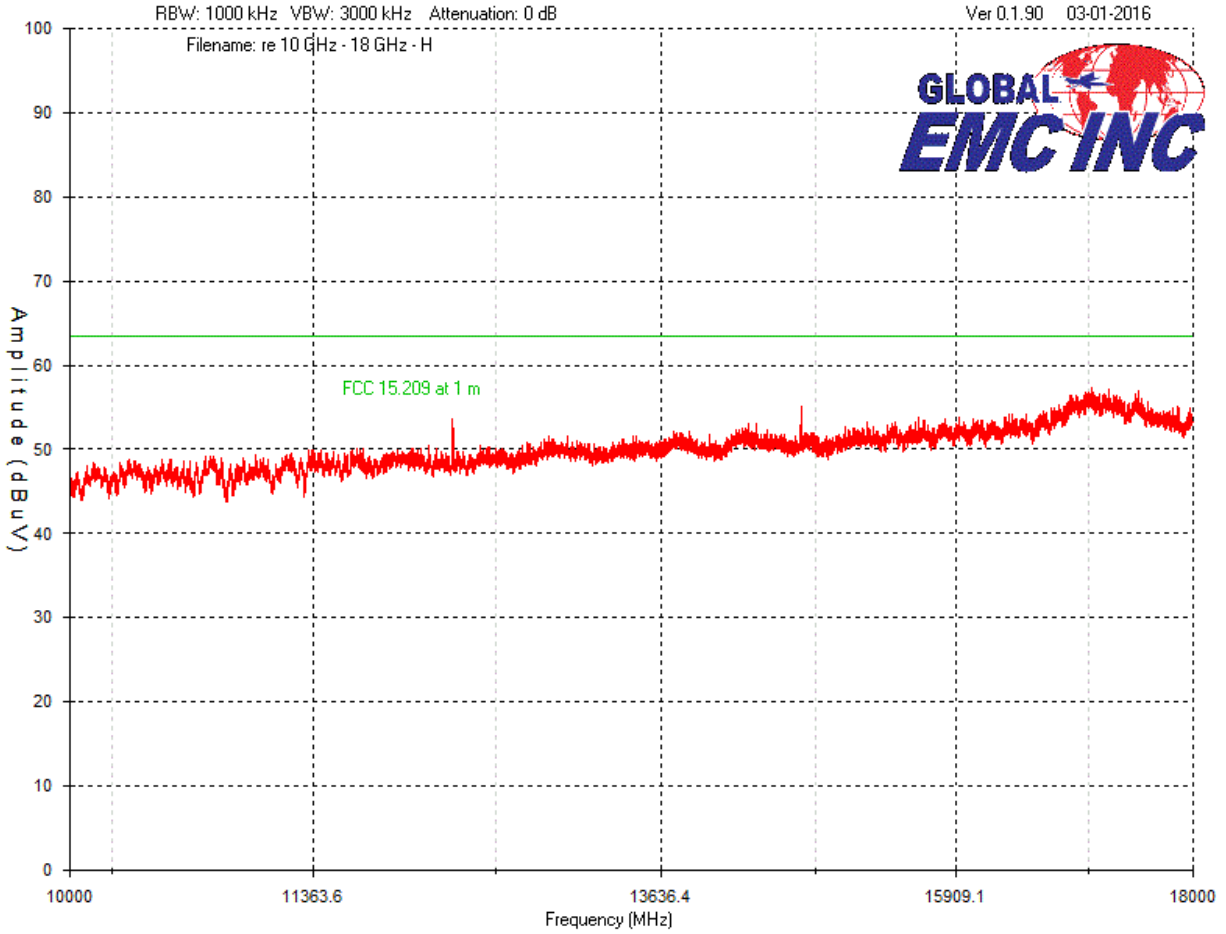

Note: See Final Measurements and Results section starting on page 54 for measurements.

Client	Visonic Ltd	
Product	MCT-370 SMA	
Standard(s)	RSS 247:2015 / FCC Part 15 Subpart C 15:2016	

Mid Channel – 18 GHz – 26 GHz  
Horizontal - Peak Emission Graph

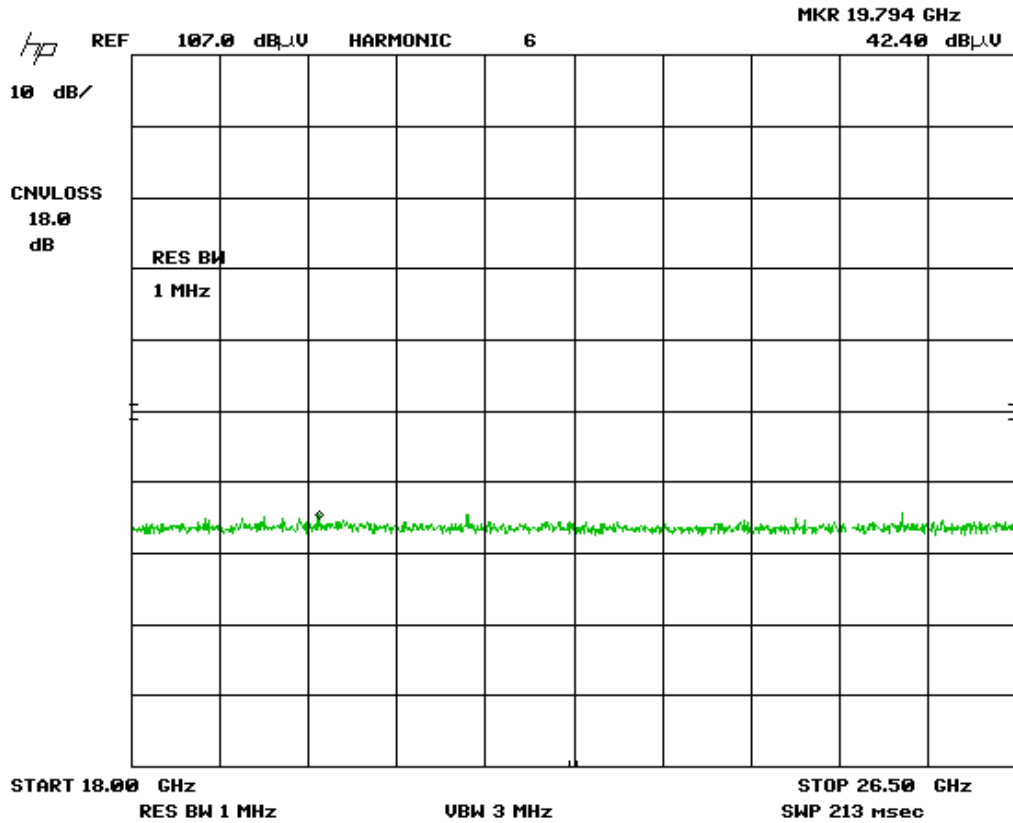

Plot was taken at 1 meter distances. All emissions shown were instrument noise floor of measurement instrument. No emissions were found in this frequency range.

Client	Visonic Ltd	
Product	MCT-370 SMA	
Standard(s)	RSS 247:2015 / FCC Part 15 Subpart C 15:2016	

Mid Channel – 18 GHz – 26 GHz  
Vertical - Peak Emission Graph

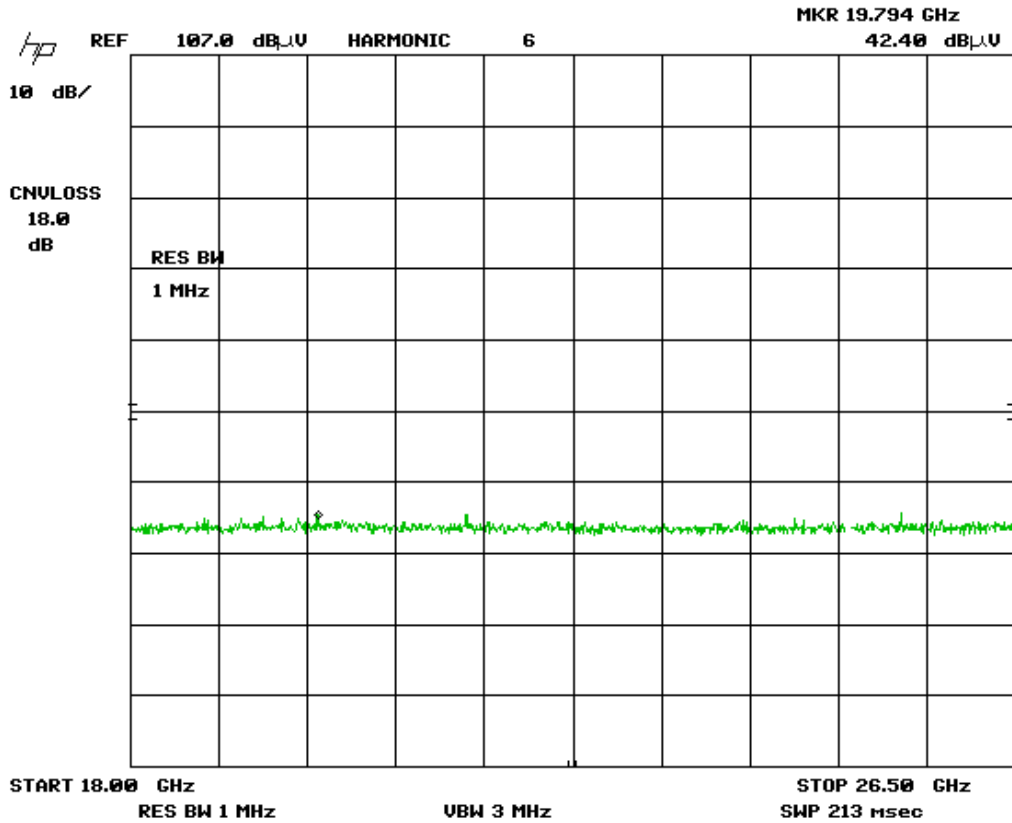

Plot was taken at 1 meter distances. All emissions shown were instrument noise floor of measurement instrument. No emissions were found in this frequency range.

Client	Visonic Ltd	
Product	MCT-370 SMA	
Standard(s)	RSS 247:2015 / FCC Part 15 Subpart C 15:2016	

Band Edge – Low Channel  
Vertical - Peak Emission

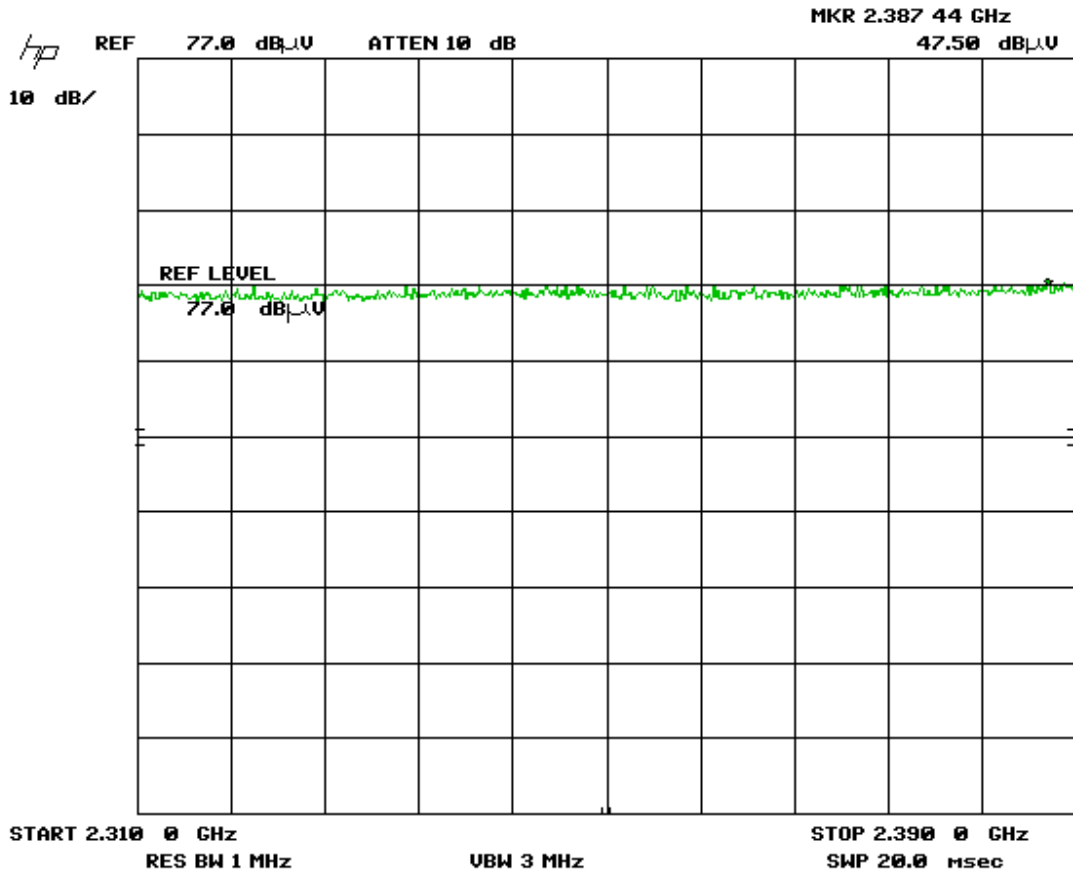

Note: Restricted band bandedge plots were taken with 3 m measurements distance. The marker shows the raw value; see Final Measurements and Results section starting on page 54 for corrected values.

Client	Visonic Ltd	
Product	MCT-370 SMA	
Standard(s)	RSS 247:2015 / FCC Part 15 Subpart C 15:2016	

Band Edge – Low Channel  
Horizontal - Peak Emission

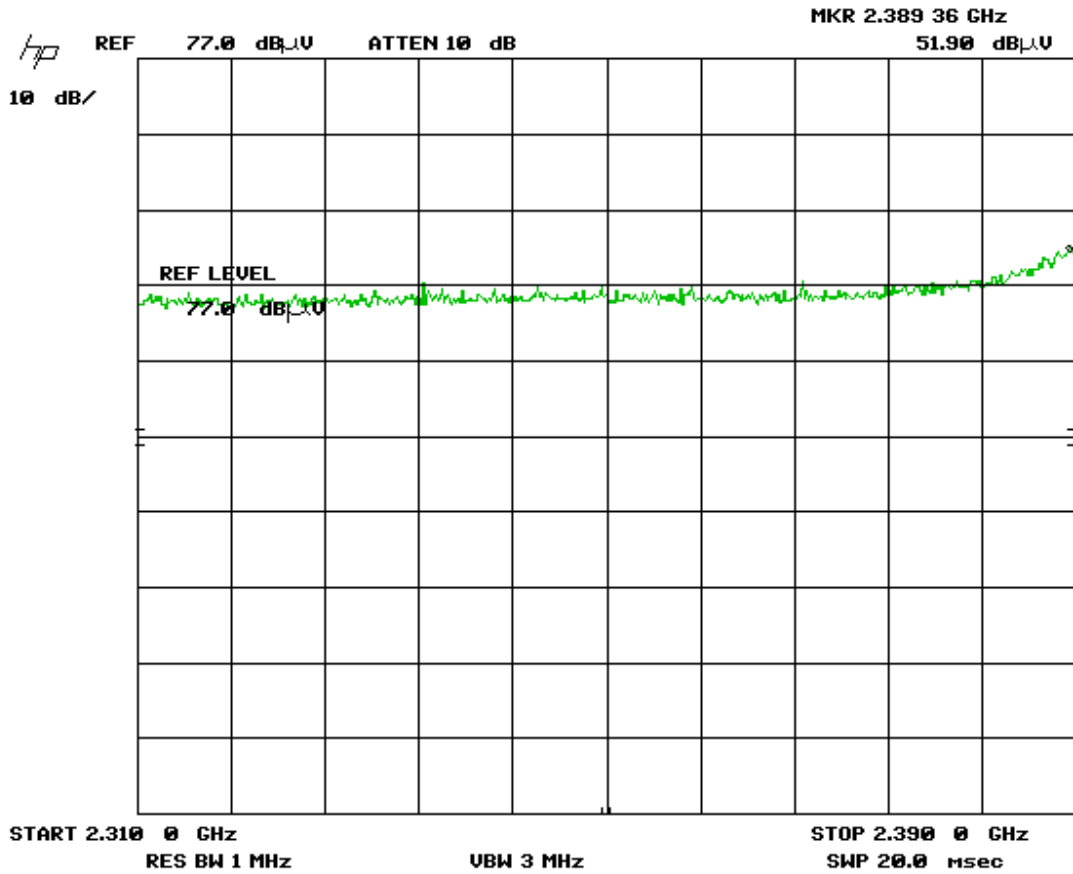

Note: Restricted band bandedge plots were taken with 3 m measurements distance. The marker shows the raw value; see Final Measurements and Results section starting on page 54 for corrected values.

Client	Visonic Ltd	
Product	MCT-370 SMA	
Standard(s)	RSS 247:2015 / FCC Part 15 Subpart C 15:2016	

Band Edge – Low Channel  
Vertical – Average Emission

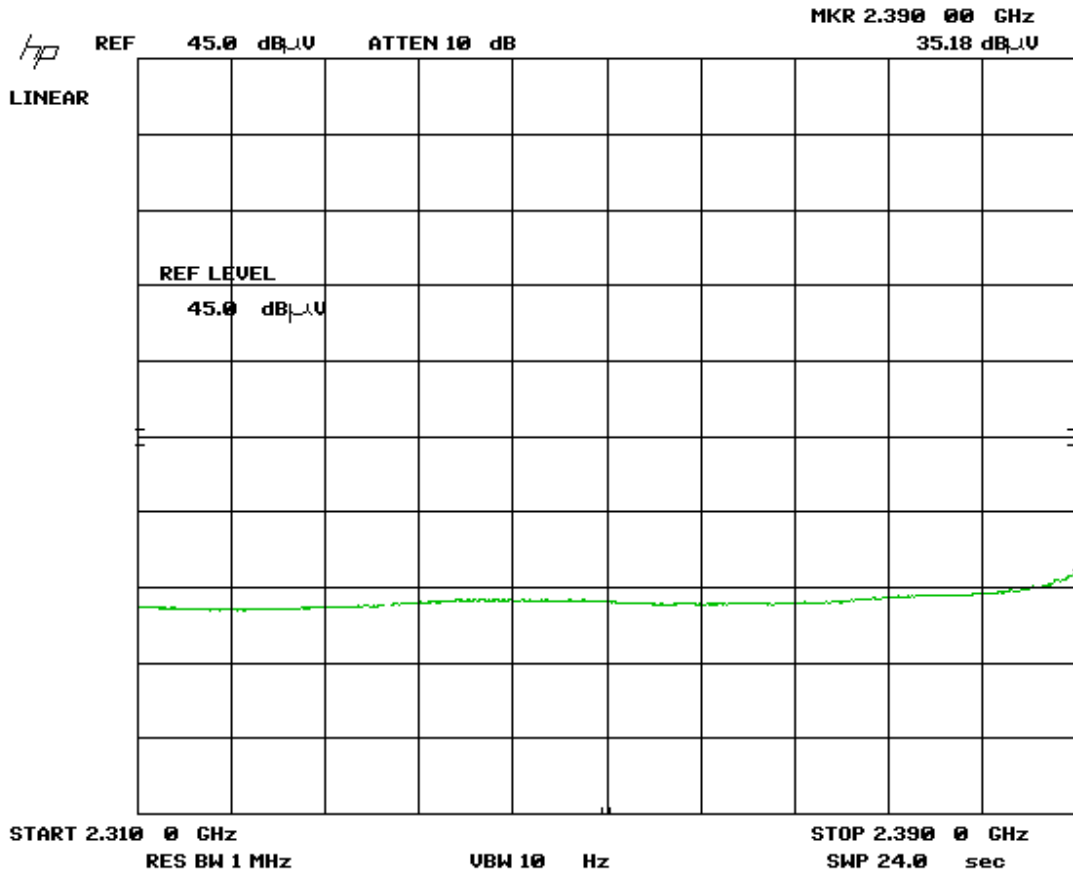

Note: Restricted band bandedge plots were taken with 3 m measurements distance. The marker shows the raw value; see Final Measurements and Results section starting on page 54 for corrected values.



Client	Visonic Ltd	
Product	MCT-370 SMA	
Standard(s)	RSS 247:2015 / FCC Part 15 Subpart C 15:2016	

Band Edge – Low Channel  
Horizontal - Average Emission

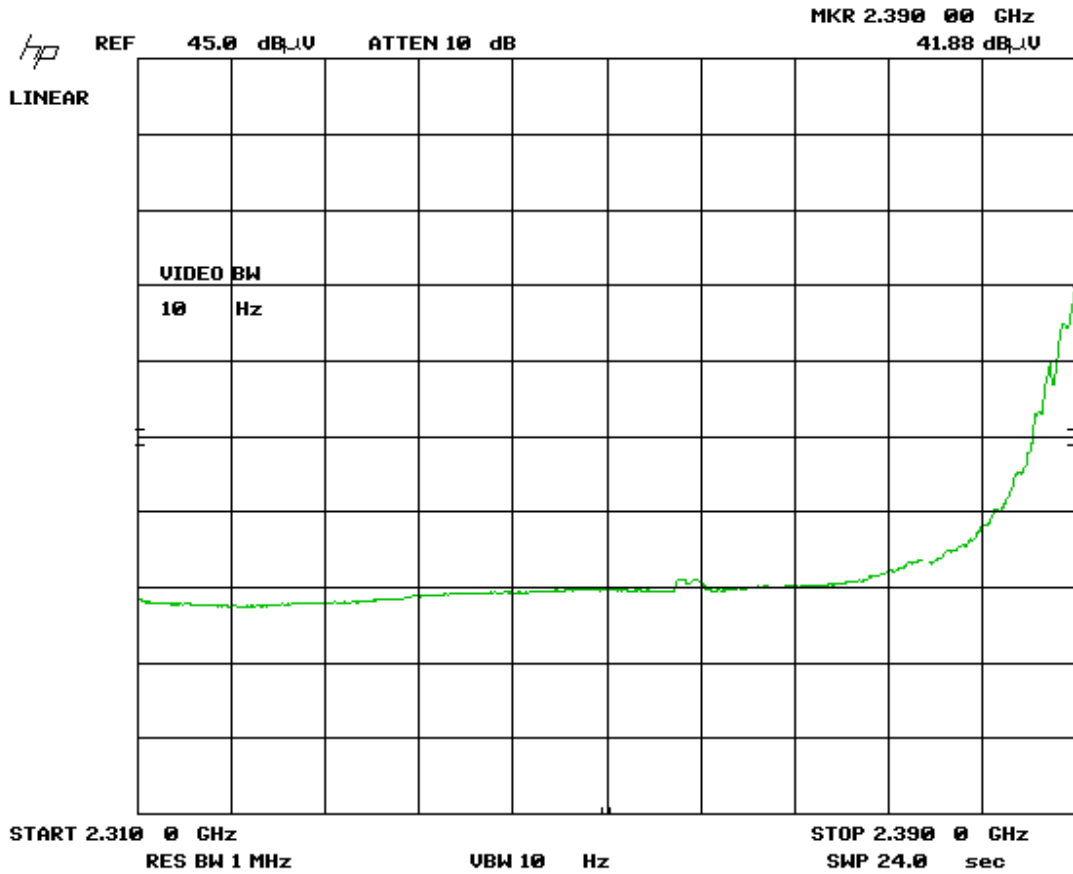

Note: Restricted band bandedge plots were taken with 3 m measurements distance. The marker shows the raw value; see Final Measurements and Results section starting on page 54 for corrected values.

Client	Visonic Ltd	
Product	MCT-370 SMA	
Standard(s)	RSS 247:2015 / FCC Part 15 Subpart C 15:2016	

Band Edge – Hi Channel (Channel 0x19)  
Vertical - Peak Emission

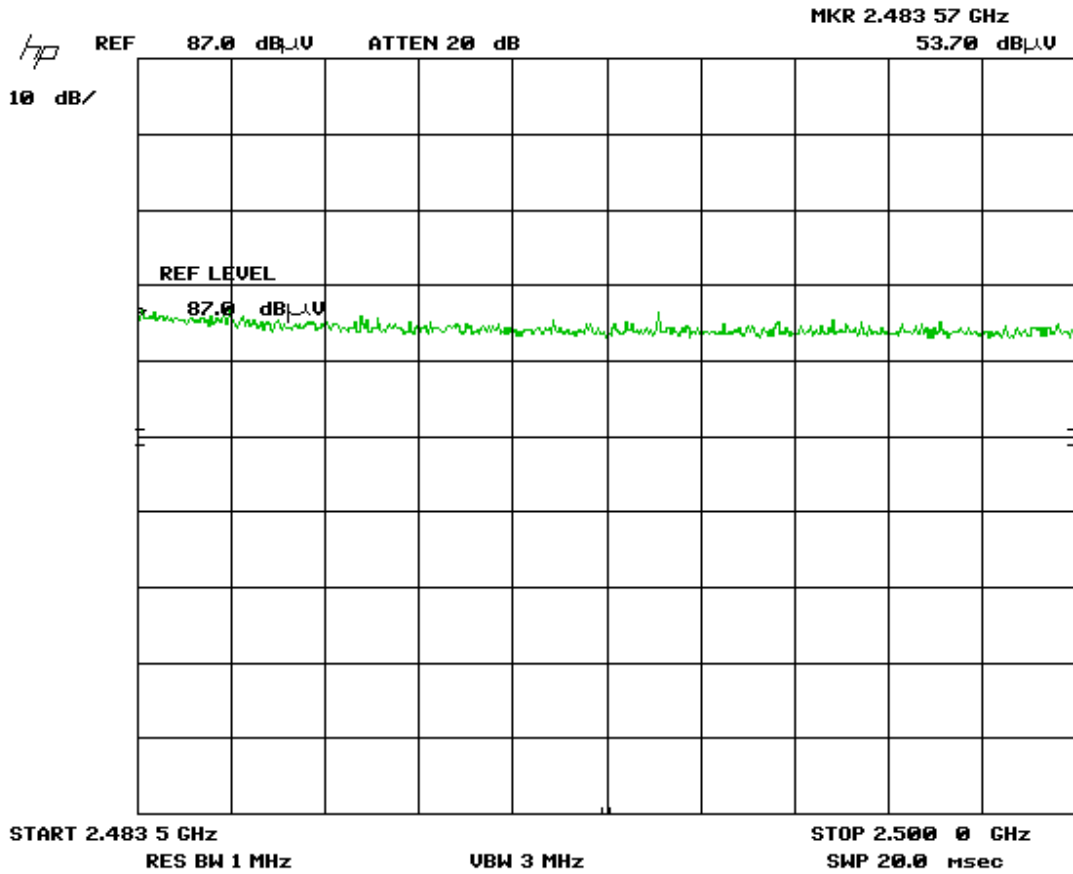

Note: Restricted band bandedge plots were taken with 3 m measurements distance. The marker shows the raw value; see Final Measurements and Results section starting on page 54 for corrected values.

Client	Visonic Ltd	
Product	MCT-370 SMA	
Standard(s)	RSS 247:2015 / FCC Part 15 Subpart C 15:2016	

Band Edge – Hi Channel (Channel 0x19)  
Horizontal - Peak Emission

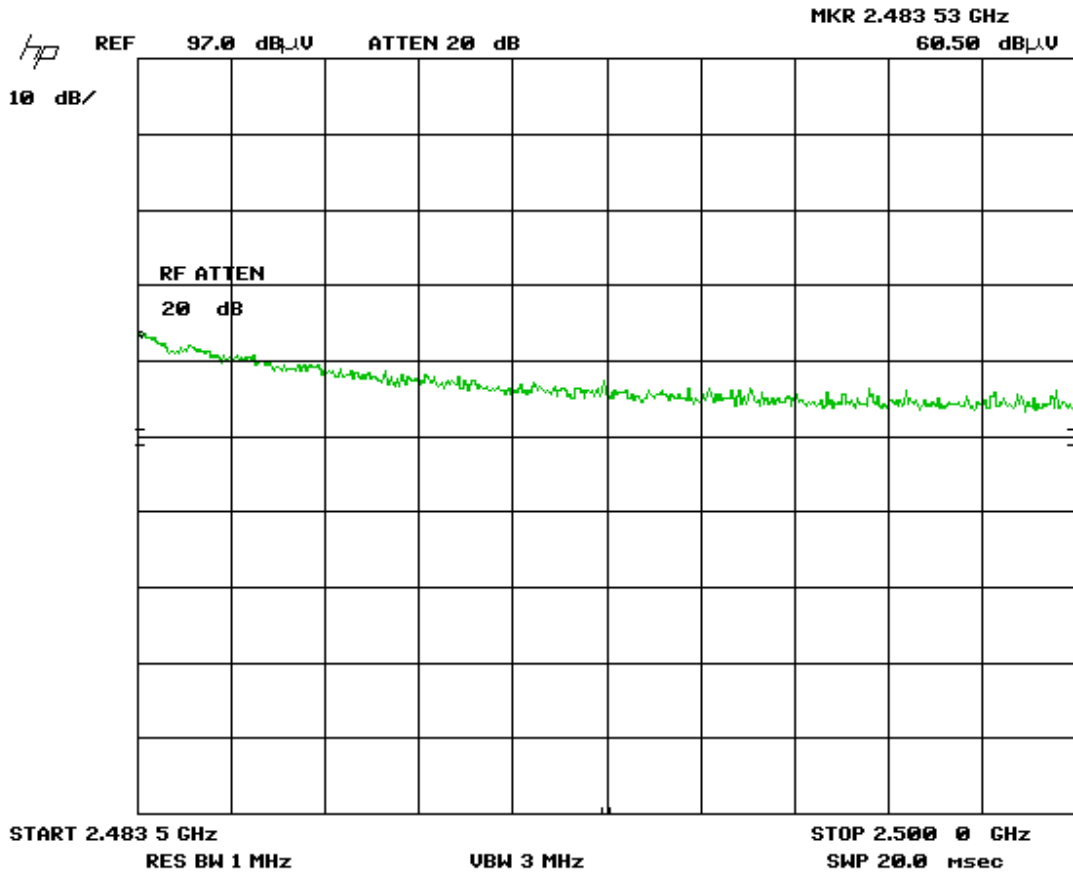

Note: Restricted band bandedge plots were taken with 3 m measurements distance. The marker shows the raw value; see Final Measurements and Results section starting on page 54 for corrected values.

Client	Visonic Ltd	
Product	MCT-370 SMA	
Standard(s)	RSS 247:2015 / FCC Part 15 Subpart C 15:2016	

Band Edge – Hi Channel (Channel 0x1A)  
Vertical – Peak Emission

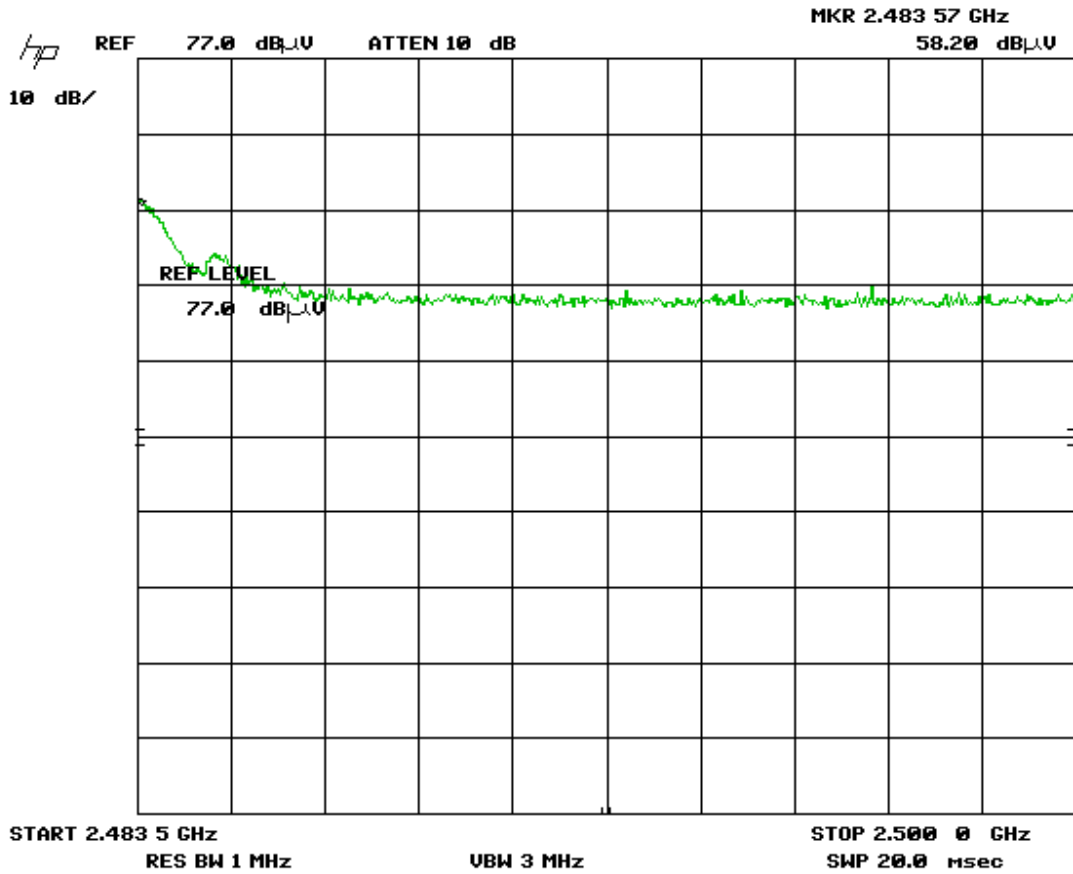

Note: Restricted band bandedge plots were taken with 3 m measurements distance. The marker shows the raw value; see Final Measurements and Results section starting on page 54 for corrected values.

Client	Visonic Ltd	
Product	MCT-370 SMA	
Standard(s)	RSS 247:2015 / FCC Part 15 Subpart C 15:2016	

Band Edge – Hi Channel (Channel 0x1A)  
Horizontal - Peak Emission

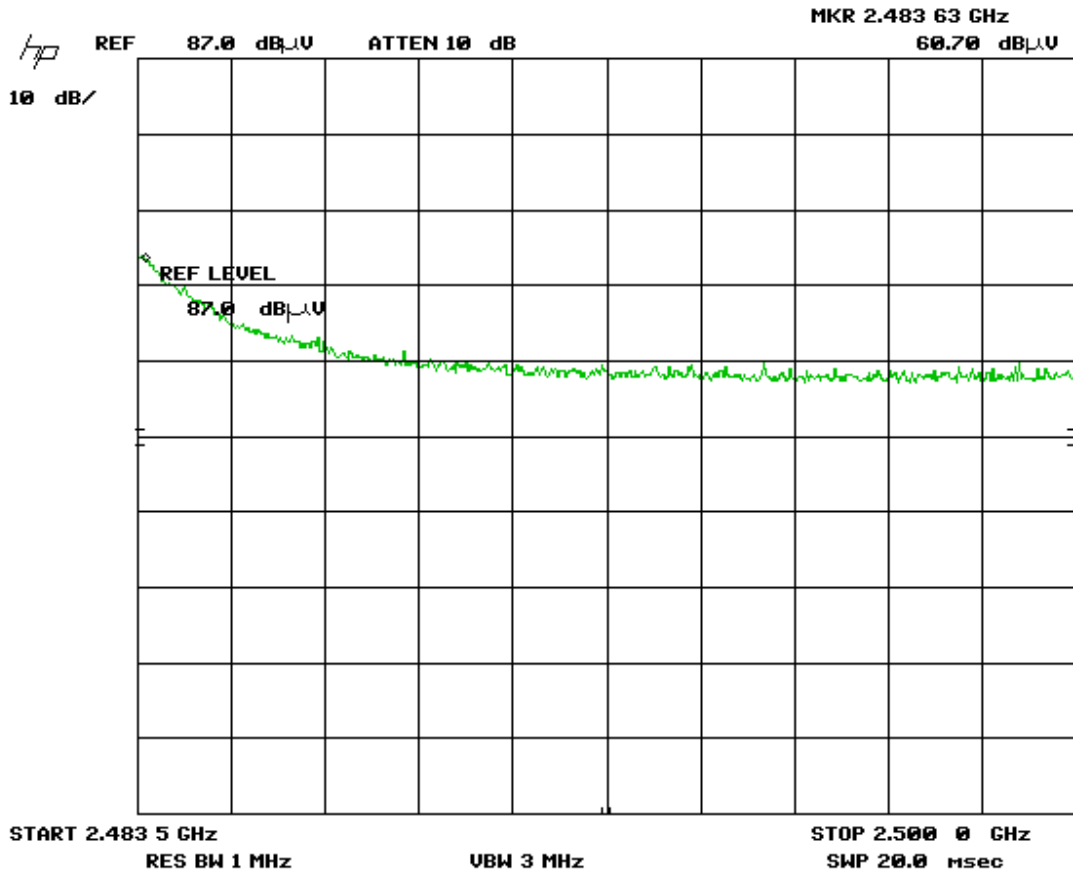

Note: Restricted band bandedge plots were taken with 3 m measurements distance. The marker shows the raw value; see Final Measurements and Results section starting on page 54 for corrected values.

Client	Visonic Ltd	
Product	MCT-370 SMA	
Standard(s)	RSS 247:2015 / FCC Part 15 Subpart C 15:2016	

## Final Measurements and Results

The EUT passed the limits. Low, middle and high bands were measured.

In accordance with 15.247(d), only frequencies exceeding the 15.209 limit that occur within the bands listed in 15.205, need to be verified with a final detector.

The measurements were maximized by rotating the turn table over a full 0-360 rotation and the antenna height was varied from 1 m to 4 m.

The EUT have a source base duty cycle of 21.52%; a duty cycle correction factor of -13.34 dB was used to derived Average emissions from peak emissions for 2.4835 – 2.5 GHz restricted band emissions and for harmonics that falls in restricted bands.

Test Frequency (MHz)	Detection mode	Antenna polarity (Horz/Vert)	Raw signal dB(μV)	Antenna factor dB	Cable loss dB	Attenuator dB	Pre-Amp Gain dB	Received signal dB(μV/m)	Emission limit dB(μV/m)	Margin dB	Result
Mid Channel (0x13) - Y axis (Vertical)											
2445	Peak	Horz	94.5	26.4	4.2	10.0	35.8	99.3			PASS
2445	Avg	Horz	92.5	26.4	4.2	10.0	35.8	97.3			PASS
2445	Peak	Vert	105.9	26.4	4.2	10.0	35.8	110.7			PASS
2445	Avg	Vert	103.6	26.4	4.2	10.0	35.8	108.4			PASS
Mid Channel (0x13) - Z axis (Horizontal)											
2445	Peak	Horz	106.3	26.4	4.2	10.0	35.8	111.1			PASS
2445	Avg	Horz	104.3	26.4	4.2	10.0	35.8	109.1			PASS
2445	Peak	Vert	96.7	26.4	4.2	10.0	35.8	101.5			PASS
2445	Avg	Vert	94.1	26.4	4.2	10.0	35.8	98.9			PASS
4890	Peak	Horz	62.0	27.7	5.8	0.0	35.3	60.2	74.0	13.8	PASS
4890	Avg	Horz	48.7	27.7	5.8	0.0	35.3	46.9	54.0	7.1	PASS
4890	Peak	Vert	57.4	27.7	5.8	0.0	35.3	55.6	74.0	18.4	PASS
4890	Avg	Vert	44.1	27.7	5.8	0.0	35.3	42.3	54.0	11.7	PASS
7335	Peak	Vert	47.6	28.9	7.1	0.0	35.5	48.1	74.0	25.9	PASS
7335	Avg	Vert	34.3	28.9	7.1	0.0	35.5	34.8	54.0	19.2	PASS
7335	Peak	Horz	51.8	28.9	7.1	0.0	35.5	52.3	74.0	21.7	PASS
7335	Avg	Horz	38.5	28.9	7.1	0.0	35.5	39.0	54.0	15.0	PASS
9780	Peak	Vert	52.1	31.2	8.7	0.0	36.1	55.9	74.0	18.1	PASS
9780	Avg	Vert	38.8	31.2	8.7	0.0	36.1	42.6	54.0	11.4	PASS
9780	Peak	Horz	51.0	31.2	8.7	0.0	36.1	54.8	74.0	19.2	PASS
9780	Avg	Horz	37.7	31.2	8.7	0.0	36.1	41.5	54.0	12.5	PASS
Mid Channel (0x13) X - Side (Flat)											
2445	Peak	Horz	104.3	26.4	4.2	10.0	35.8	109.1			PASS
2445	Avg	Horz	101.9	26.4	4.2	10.0	35.8	106.7			PASS
2445	Peak	Vert	97.4	26.4	4.2	10.0	35.8	102.2			PASS
2445	Avg	Vert	95.4	26.4	4.2	10.0	35.8	100.2			PASS

Client	<b>Visonic Ltd</b>	
Product	<b>MCT-370 SMA</b>	
Standard(s)	<b>RSS 247:2015 / FCC Part 15 Subpart C 15:2016</b>	

Test Frequency (MHz)	Detection mode	Antenna polarity (Horz/Vert)	Raw signal dB(µV)	Antenna factor dB	Cable loss dB	Attenuator dB	Pre-Amp Gain dB	Received signal dB(µV/m)	Emission limit dB(µV/m)	Margin dB	Result
Low Channel (11) - Z axis (Flat)											
2405	Peak	Horz	106.2	26.4	4.2	10.0	35.8	111.0			PASS
2405	Avg	Horz	104.2	26.4	4.2	10.0	35.8	109.0			PASS
2405	Peak	Vert	97.3	26.4	4.2	10.0	35.8	102.1			PASS
2405	Avg	Vert	95.2	26.4	4.2	10.0	35.8	100.0			PASS
2390	Peak	Horz	51.9	26.4	4.2	10.0	35.8	56.7	74.0	17.3	PASS
2390	Avg	Horz	41.9	26.4	4.2	10.0	35.8	46.7	54.0	7.3	PASS
2390	Peak	Vert	47.5	26.4	4.2	10.0	35.8	52.3	74.0	21.7	PASS
2390	Avg	Vert	35.2	26.4	4.2	10.0	35.8	40.0	54.0	14.0	PASS
High Channel (0x19) - Z axis (Flat)											
2475	Peak	Horz	106.3	26.4	4.2	10.0	35.8	111.1			PASS
2475	Avg	Horz	104.1	26.4	4.2	10.0	35.8	108.9			PASS
2475	Peak	Vert	92.8	26.4	4.2	10.0	35.8	97.6			PASS
2475	Avg	Vert	90.8	26.4	4.2	10.0	35.8	95.6			PASS
2483.5	Peak	Horz	60.2	26.4	4.2	10.0	35.8	65.0	74.0	9.0	PASS
2483.5	Avg	Horz	46.9	26.4	4.2	10.0	35.8	51.7	54.0	2.3	PASS
2483.5	Peak	Vert	53.7	26.4	4.2	10.0	35.8	58.5	74.0	15.5	PASS
2483.5	Avg	Vert	40.4	26.4	4.2	10.0	35.8	45.2	54.0	8.8	PASS
High Channel (0x1A) - Z Axis (Flat)											
2480	Peak	Horz	86.7	26.4	4.2	10.0	35.8	91.5			PASS
2480	Avg	Horz	84.8	26.4	4.2	10.0	35.8	89.6			PASS
2480	Peak	Vert	75.5	26.4	4.2	10.0	35.8	80.3			PASS
2480	Avg	Vert	73.4	26.4	4.2	10.0	35.8	78.2			PASS
2483.5	Peak	Horz	60.7	26.4	4.2	10.0	35.8	65.5	74.0	8.5	PASS
2483.5	Avg	Horz	47.4	26.4	4.2	10.0	35.8	52.2	54.0	1.8	PASS
2483.5	Peak	Vert	58.2	26.4	4.2	10.0	35.8	63.0	74.0	11.0	PASS
2483.5	Avg	Vert	44.9	26.4	4.2	10.0	35.8	49.7	54.0	4.3	PASS

Client	<b>Visonic Ltd</b>	
Product	<b>MCT-370 SMA</b>	
Standard(s)	<b>RSS 247:2015 / FCC Part 15 Subpart C 15:2016</b>	

## Test Equipment List

Equipment	Model No.	Manufacturer	Last calibration / Verification date	Next calibration/ Verification due date	Asset #
Spectrum Analyzer	8566B	HP	Nov 27, 2015	Nov 27, 2017	GEMC 190
Quasi Peak Adapter	85650A	HP	Nov 27, 2015	Nov 27, 2017	GEMC 191
Loop Antenna	EM 6871	Electro-Metrics	Feb 3, 2015	Feb 5, 2017	GEMC 70
Loop Antenna	EM 6872	Electro-Metrics	Feb 3, 2015	Feb 5, 2017	GEMC 71
BiLog Antenna	3142-C	ETS	Sept 8, 2014	Sept 8, 2016	GEMC 8
Attenuator 10 dB	8493B	Agilent	Feb 11, 2016	Feb 11, 2017	GEMC 133
4GHZ-12GHz High Pass filter	11SH10-4000/T12000-0/0	K & L Microwave	Apr 9, 2015	Apr 9, 2016	GEMC 119
Chase Preamp 9kHz - 2 GHz	CPA9231A	Chase	Sept 9, 2014	Sept 9, 2016	GEMC 6403
Q-Par Horn Antenna (2 to 18 GHz)	WBH218HN	Q-par	Feb 12, 2016	Feb 12, 2018	GEMC 6375
Horn Antenna 18 GHz - 26.5 GHz	SAS-572	A.H. Systems	Sept 9, 2014	Sept 9, 2016	GEMC 6371
18.0-26.5 GHz Harmonic Mixer	11970K	HP	Feb 8, 2016	Feb 8, 2018	GEMC 158
1-26G pre-amp	HP 8449B	HP	Sept 9, 2014	Sept 9, 2016	GEMC 6351
2.0-8.0 GHz Amplifier	11975A	HP	Feb 8, 2016	Feb 8, 2018	GEMC157
RF Cable 7m	LMR-400-7M-50OHM-MN-MN	LexTec	Feb 1, 2016	Feb 1, 2017	GEMC 28
RF Cable 1m	LMR-400-1M-50OHM-MN-MN	LexTec	Feb 1, 2016	Feb 1, 2017	GEMC 29
RF Cable 0.5M	LMR-400-0.5M-50OHM-MN-MN	LexTec	Feb 1, 2016	Feb 1, 2017	GEMC 31

This report module is based on GEMC template "FCC - 15.209 - Radiated Emissions\_Rev1.doc"



Client	<b>Visonic Ltd</b>	
Product	<b>MCT-370 SMA</b>	
Standard(s)	RSS 247:2015 / FCC Part 15 Subpart C 15:2016	

## ***Power Spectral Density – 15.247 DM***

### **Purpose**

The purpose of this test is to ensure that the maximum power spectral density to the radiating element does not exceed the limits specified. This ensures that the modulation is significantly wide enough, or low enough in power that it will allow for co-operation of other wireless devices operating within this frequency allocation.

### **Limits and Methods**

The limits are defined in 15.247(e).

For digitally modulated systems, the power spectral density conducted from the intentional radiator to the antenna shall not be greater than 8 dBm in any 3 kHz band during any time interval of continuous transmission.

The method is given in Section 10.2 of FCC KDB 558074.

### **Results**

The EUT passed. Low, medium, and high band was tested. The worst case PSD is 5.72 dBm/3 kHz.

### **Graph(s)**

The graphs shown below show the power spectral density of the device during the conducted measurement operation of the EUT. Low, middle, and high channel was investigated in each mode, with the worst case being presented. The external attenuator and cable loss are accounted for as reference offset in the spectrum analyzer.

Client	<b>Visonic Ltd</b>	
Product	<b>MCT-370 SMA</b>	
Standard(s)	<b>RSS 247:2015 / FCC Part 15 Subpart C 15:2016</b>	

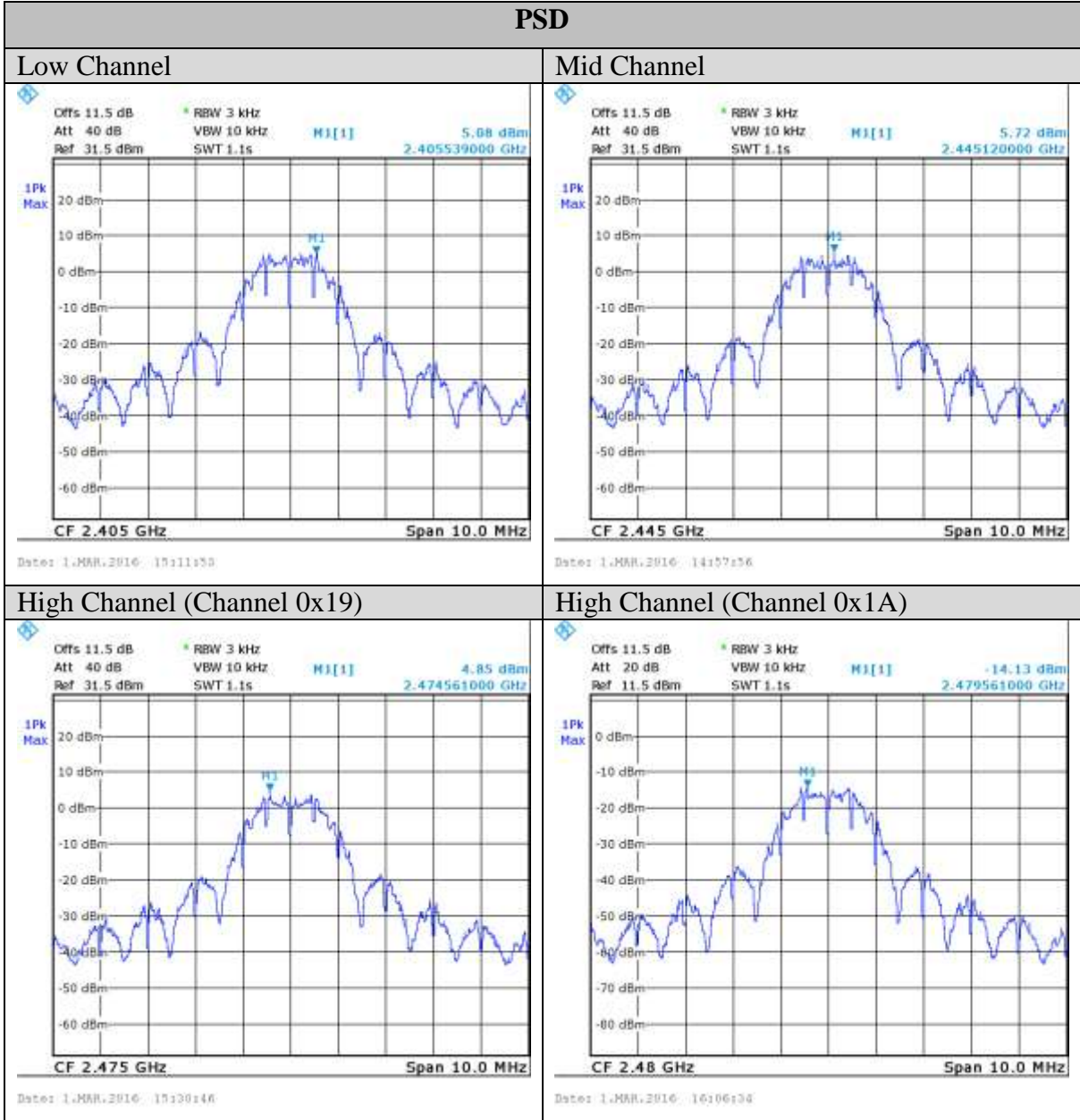

Note: See 'Appendix B – EUT & Test Setup Photographs' for photos showing the test set-up.

Client	<b>Visonic Ltd</b>	
Product	<b>MCT-370 SMA</b>	
Standard(s)	RSS 247:2015 / FCC Part 15 Subpart C 15:2016	

### Test Equipment List

Equipment	Model No.	Manufacturer	Last calibration / Verification date	Next calibration/ Verification due date	Asset #
Spectrum Analyzer	ESL6	Rohde & Schwarz	Nov 25, 2015	Nov 25, 2017	GEMC 160
Attenuator 10 dB	8493B	Agilent	Feb-11, 2016	Feb-11, 2017	GEMC133

This report module is based on GEMC template "FCC – Power Line Conducted Emissions Class B\_Rev1"

Client	<b>Visonic Ltd</b>	
Product	<b>MCT-370 SMA</b>	
Standard(s)	RSS 247:2015 / FCC Part 15 Subpart C 15:2016	

## ***RF Exposure***

### **Purpose**

The purpose of this test is to ensure that the RF energy intentionally transmitted, in terms of power density emitted from the EUT at a stated operating distance does not exceed the limits listed below as defined in the applicable test standard, as calculated based upon readings obtained during testing. This helps protect human exposure to excessive RF fields.

### **Limit(s) and Method**

The limits, as defined FCC 1.1310 Table 1 (B) limits for general public exposure was applied. The limits for the frequency ranges 300 MHz to 1.5 GHz and 1.5 GHz to 100 GHz was applied. The limits are  $f/1500 \text{ mW/cm}^2$  and  $1.0 \text{ mW/cm}^2$  respectively. The distance used for calculations was 20 cm, as this is the minimum distance an operator will be from the EUT during normal operation, as stated by the manufacturer.

As per FCC KDB 447498, Clause 4.3.1 b), the 1-g SAR exclusion threshold for 200 mm test distance is 1597 mW.

### **Results**

The EUT passed the requirements. The worst case calculated power density was  $0.027 \text{ mW/cm}^2$ , this is significantly under the  $1.0 \text{ mW/cm}^2$  requirement.

The Maximum peak conducted power of the EUT is 119 mW and is significantly less than the SAR exclusion threshold. Therefore SAR is not applicable to the EUT.

### **Calculations**

Method 1 (conducted power)

$$P_d = (P_t * G) / (4 * \pi * R^2)$$

Where  $P_t = 20.75 \text{ dBm}$  or  $118.85 \text{ mW}$  as per Peak power conducted output

Where  $G = 0.5 \text{ dBi}$ , or numerically 1.12

Where  $R = 20 \text{ cm}$

$$P_d = (118.85 \text{ mW} * 1.12) / (4 * \pi * 20\text{cm}^2)$$

$$P_d = 0.027 \text{ mW/cm}^2$$

Client	<b>Visonic Ltd</b>	
Product	<b>MCT-370 SMA</b>	
Standard(s)	RSS 247:2015 / FCC Part 15 Subpart C 15:2016	

Client	<b>Visonic Ltd</b>	
Product	<b>MCT-370 SMA</b>	
Standard(s)	RSS 247:2015 / FCC Part 15 Subpart C 15:2016	

**Appendix A – EUT Summary**

Client	Visonic Ltd	
Product	MCT-370 SMA	
Standard(s)	RSS 247:2015 / FCC Part 15 Subpart C 15:2016	

For further details for filing purposes, refer to filing package.

## General EUT Description

Client	
<b>Organization</b>	Visonic Ltd 24 Habarzel Str Tel Aviv, 61920 Isreal
<b>Contact</b>	Arik Elshtein
<b>Phone</b>	+972 3 6456832
<b>Email</b>	<a href="mailto:aelshtein@tycoint.com">aelshtein@tycoint.com</a>
EUT Details	
<b>EUT Name (for report title)</b>	MCT-370 SMA
<b>EUT Model / SN (if known)</b>	MCT-370 SMA
<b>FCC ID</b>	WP3MCT370SMA5
<b>Industry Canada #</b>	1467C-MCT370SMA
<b>Equipment category</b>	Residential
<b>EUT is powered using</b>	Battery
<b>Input voltage range(s) (V)</b>	3 VDC
<b>Frequency range(s) (Hz)</b>	DC
<b>Transmits RF energy? (describe)</b>	Yes, 2.4 – 24835 GHz Zigbee device
<b>Basic EUT functionality description</b>	Door contact.

Note the EUT is considered to have been received the date of the commencement of the first test, unless otherwise stated. For a close-up picture of the EUT, see ‘Appendix B – EUT & Test Setup Photographs’.

Client	<b>Visonic Ltd</b>	
Product	<b>MCT-370 SMA</b>	
Standard(s)	RSS 247:2015 / FCC Part 15 Subpart C 15:2016	

## EUT Configuration

Please see Appendix B for a picture of the unit running in normal conditions.

- Wireless were configured to transmit at 100% duty cycle

## Operational Setup

No additional device were required to be attached to the EUT for its normal operation.

## Duty Cycle

The source base duty cycle was provided by the client. The instructions below details how the duty cycle was measured:

- EUT device MCT-370 SMA enrolled with iControl Model TCA-203 (coordinator) and operating properly
- Remove coordinator (power down)
- EUT device will transmit data trying to join the ZigBee network
- Captured pulses look as attached (see captured screen shot)
- Check-in message (1.958ms x 11 pulses Tx time in 100ms)
- Calculation  $AF = -20\log(Tx(ms)/100ms) = 20 \times \log(21.538/100) = -13.335dB$





Client	<b>Visonic Ltd</b>	
Product	<b>MCT-370 SMA</b>	
Standard(s)	RSS 247:2015 / FCC Part 15 Subpart C 15:2016	

## **Appendix B – EUT and Test Setup Photographs**

Client	Visonic Ltd	
Product	MCT-370 SMA	
Standard(s)	RSS 247:2015 / FCC Part 15 Subpart C 15:2016	



**Figure 1: Radiated emissions setup – photo 1**

Client	Visonic Ltd	
Product	MCT-370 SMA	
Standard(s)	RSS 247:2015 / FCC Part 15 Subpart C 15:2016	



**Figure 2: Radiated emission setup – photo 2**

Client	<b>Visonic Ltd</b>	
Product	<b>MCT-370 SMA</b>	
Standard(s)	RSS 247:2015 / FCC Part 15 Subpart C 15:2016	



**Figure 3: Radiated emission setup – photo 3**

Client	Visonic Ltd	
Product	MCT-370 SMA	
Standard(s)	RSS 247:2015 / FCC Part 15 Subpart C 15:2016	



**Figure 4: Radiated emission setup – photo 4**

Client	Visonic Ltd	
Product	MCT-370 SMA	
Standard(s)	RSS 247:2015 / FCC Part 15 Subpart C 15:2016	

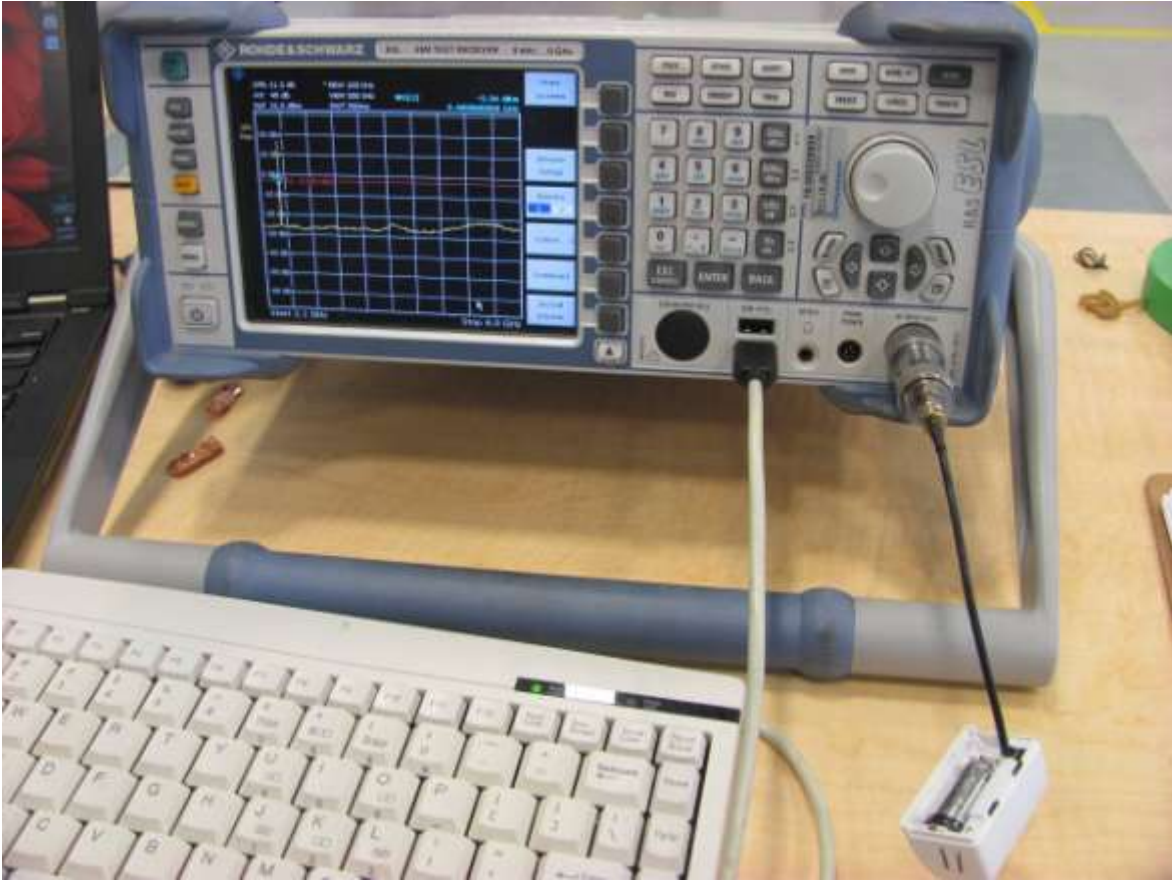

**Figure 5: Antenna port conducted emission - photo**