

MC-302 PG2

Supervised PowerG Magnetic Contact Device



Visonic[®]

Installation Instructions

1. INTRODUCTION

The MCT-302 PG2 is a fully supervised, PowerG magnetic contact device. The device includes a built-in reed switch (that opens upon removal of a magnet placed near it). The MC-302 PG sends the parameters of the specific alarm to the control panel using PowerG 2-way communications protocol.

The MC-302 PG 2 tamper switch is activated when the cover is removed.

A periodic supervision message is transmitted automatically. The control panel is thus informed, at regular intervals, of the unit's active participation in the system.

An LED lights whenever alarm or tamper events are reported. The LED does not light while a supervision message is being transmitted.

Operating power is obtained from an on-board 3 V Lithium battery. When the battery voltage is low, a "low battery" message is sent to the receiver.

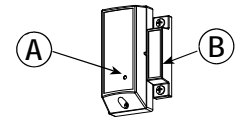

A. Transmission LED
B. Magnet

Figure 1:
External View

2. SPECIFICATIONS

Frequency Band (MHz): Europe: 433, 868, USA: 915

Modulation: GFSK

Antenna: Built-in helical antenna.

Communication Protocol: PowerG.

Alarm Input: One internal.

Supervision: Signaling at 4-min. intervals.

Tamper Alert: Reported when a tamper event occurs.

Power Supply: Type C

Battery type: 3 V Lithium CR-123 type battery, Panasonic or Sanyo only.

Caution!

Risk of explosion if battery is replaced by an incorrect type. Dispose of used battery according to manufacturer's instructions.

Battery Life Expectancy: 8 years (for typical use)

Battery Supervision: Automatic transmission of battery condition data as part of periodic status report and immediately upon low battery condition detection.

Operating Temperature: 0°C to 49°C (32°F to 120°F).

Humidity: Average relative humidity of approximate 75% non-condensing. For 30 days per year relative humidity may vary between 85 % and 95 % non-condensing.

Dimensions: 81 x 34 x 25 mm (3-3/16 x 1-1/4 x 1 in.)

Weight: 53g (1.9 oz)

Compliance with Standards:

USA: CFR47 part 15 (FCC)

Europe: EN 301 489-3, EN 50130-4:(95) & A1 : (98) & A2: (03), EN 300 220-2, EN 60950-1, EN 50130-5, EN 50131-1, CLC/TS 50131-2-6, EN 50131-6

Canada: RSS 210

This device complies with Part 15 of the FCC Rules and RSS-210 of Industry and Science Canada. Operation is subject to the following two conditions: (1) This device may not cause harmful interference, and (2) this device must accept any interference received, including interference that may cause undesired operation.

This device complies with the essential requirements and provisions of Directive 1999/5/EC of the European Parliament and of the Council of 9 March 1999 on radio and telecommunications terminal equipment.

3. INSTALLATION

3.1 Mounting (Fig. 3a and 3b)

It is highly recommended to attach the transmitter to the top of the door/window on the fixed frame and the magnet to the movable part (door or window). Make sure that the magnet is located not more than 6 mm (0.25 in.) from the transmitter's marked side.

Note: Once the cover is removed, a tamper message is transmitted to the receiver. Subsequent removal of the battery prevents transmission of "TAMPER RESTORE", leaving the receiver in permanent alert. To avoid this, during the enrolling process, press the tamper switch while you remove the battery.

Attention! The unit has a back tamper switch (optional) under the PCB. As long as the PCB is seated firmly within the base, the switch lever will be pressed against a special break-away base segment that is loosely connected to the base (Figures 2 and 3a).

Be sure to fasten the break-away segment to the wall. If the detector unit is forcibly removed from the wall, this segment will break away from the base, causing the tamper switch to open.

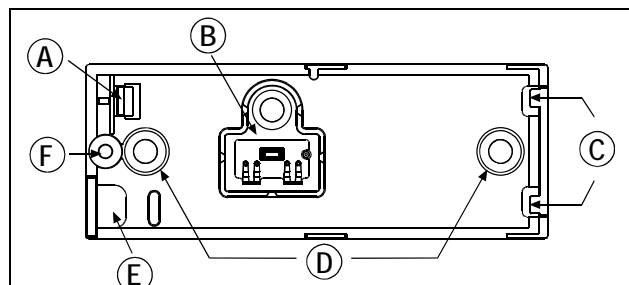

A. Flexible Retainer
B. Break-away base segment (for Back Tamper)
C. P.C. board edge supports
D. Mounting holes
E. Wiring inlet
F. Plastic standoff for case closure screw

Figure 2. Base with P.C. Board Removed

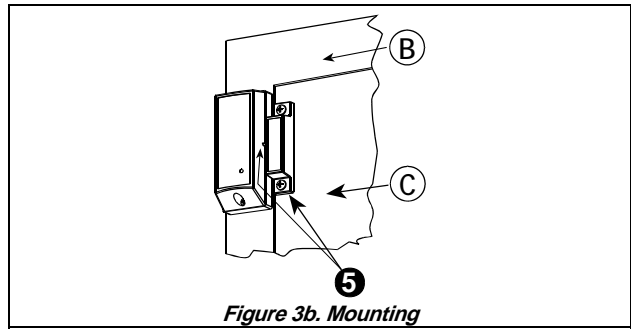
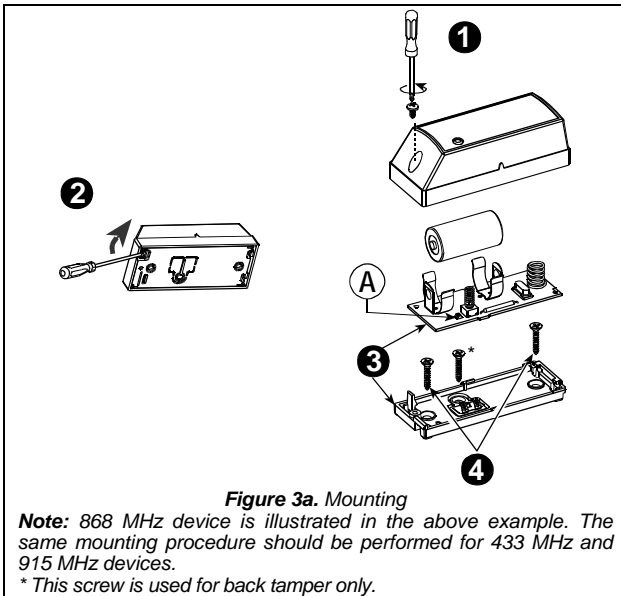

1. Remove screw
 2. Separate base from cover.
 3. Flex catch and remove P.C. board
 4. Mark & drill 2 holes in mounting surface.
Fasten base with 2 countersunk screws.
 5. Mount the magnet near its location mark with 2 screws
- A. Enroll button
 B. Fixed frame
 C. Moving part

WARNING! To comply with FCC RF exposure compliance requirements, the magnet contact device should be located in a distance of at least 20 cm from all persons during normal operation. The antennas used for this product must not be co-located or operated in conjunction with any other antenna or transmitter.

4. ENROLLMENT

Refer to the PowerMaster-10 Installer Guide for the device enrollment procedure.

5. MODIFY DEVICE SETTINGS

This section describes how to configure the parameters of contact sensors from the PowerMaster-10 control panel.

To Modify the Contact Sensor Settings

Refer to the PowerMaster-10 Installer Guide and perform the procedure for Adding A Wireless Device (section 4.5.2), or, Modifying a Device (section 4.5.5). Then continue below to modify the device settings.

- DEV SETTINGS
1. | OK
Alarm LED Here you determine whether or not the alarm LED indication will be activated.
 2. | OK
LED ON
 3. or Select between "LED ON" and "LED OFF".
 4. | OK
Alarm LED

When exiting "ZONES / DEVICES" menu, the PowerMaster-10 system displays the number of devices that need to be updated, as follows: DEV UPDATING NNN.

For detailed instructions on Adding Devices, Deleting Devices, Replacing Devices and Defining Defaults see the PowerMaster-10 Installer Guide.

6. LOCAL DIAGNOSTICS TEST

Before testing, separate the base from the cover (see Fig. 3a).

- A. Press the tamper switch once and release it.
- B. Put back the cover to return the tamper switch to its normal (undisturbed) position, and then secure the front cover to the base with the case closure screw.
- C. Momentarily open the door or window and verify the red LED blinks, indicating detection.
- D. After 2 seconds the LED blinks 3 times.
The following table indicates received signal strength indication.

LED response	Reception
Green LED blinks	Strong
Orange LED blinks	Good
Red LED blinks	Poor
No blinks	No communication

IMPORTANT! Reliable reception must be assured. Therefore, "poor" signal strength is not acceptable. If you receive a "poor"

signal from the device, re-locate it and re-test until a "good" or "strong" signal strength is received.

7. MISCELLANEOUS COMMENTS

Visonic Ltd. wireless systems are very reliable and are tested to high standards. However, due to low transmitting power and limited range (required by FCC and other regulatory authorities), there are some limitations to be considered:

A. Receivers may be blocked by radio signals occurring on or near their operating frequencies, regardless of the digital code used.

Note: For detailed Diagnostics Test instructions refer to PowerMaster-10 Installer Guide.

B. A receiver responds only to one transmitted signal at a time.

C. Wireless devices should be tested regularly to determine whether there are sources of interference and to protect against faults.

The user is cautioned that changes or modifications to the unit, not expressly approved by Visonic Ltd., could void the user's FCC or other authority to operate the equipment.

The digital circuitry of this device has been tested and found to comply with the limits for a Class B digital device, pursuant to Part 15 of the FCC Rules. These limits are designed to provide reasonable protection against harmful interference in residential installations. This equipment generates, uses and can radiate radio frequency energy and, if not installed and used in accordance with the instructions, may cause harmful interference to radio and television reception. However, there is no guarantee that interference will not occur in a particular installation. If this device does cause such interference, which can be verified by turning the device off and on, the user is encouraged to eliminate the interference by one or more of the following measures:

- Re-orient or re-locate the receiving antenna.
- Increase the distance between the device and the receiver.
- Connect the device to an outlet on a circuit different from the one which supplies power to the receiver.
- Consult the dealer or an experienced radio/TV technician

WARRANTY

Visonic Limited (the "Manufacturer") warrants this product only (the "Product") to the original purchaser only (the "Purchaser") against defective workmanship and materials under normal use of the Product for a period of twelve (12) months from the date of shipment by the Manufacturer.

This Warranty is absolutely conditional upon the Product having been properly installed, maintained and operated under conditions of normal use in accordance with the Manufacturers recommended installation and operation instructions. Products which have become defective for any other reason, according to the Manufacturers discretion, such as improper installation, failure to follow recommended installation and operational instructions, neglect, willful damage, misuse or vandalism, accidental damage, alteration or tampering, or repair by anyone other than the manufacturer, are not covered by this Warranty.

The Manufacturer does not represent that this Product may not be compromised and/or circumvented or that the Product will prevent any death and/or personal injury and/or damage to property resulting from burglary, robbery, fire or otherwise, or that the Product will in all cases provide adequate warning or protection. The Product, properly installed and maintained, only reduces the risk of such events without warning and it is not a guarantee or insurance that such events will not occur.

THIS WARRANTY IS EXCLUSIVE AND EXPRESSLY IN LIEU OF ALL OTHER WARRANTIES, OBLIGATIONS OR LIABILITIES, WHETHER WRITTEN, ORAL, EXPRESS OR IMPLIED, INCLUDING ANY WARRANTY OF MERCHANTABILITY OR FITNESS FOR A PARTICULAR PURPOSE, OR OTHERWISE. IN NO CASE SHALL THE MANUFACTURER BE LIABLE TO ANYONE FOR ANY CONSEQUENTIAL OR INCIDENTAL DAMAGES FOR BREACH OF THIS WARRANTY OR ANY OTHER WARRANTIES WHATSOEVER, AS AFORESAID.

THE MANUFACTURER SHALL IN NO EVENT BE LIABLE FOR ANY SPECIAL, INDIRECT, INCIDENTAL, CONSEQUENTIAL OR PUNITIVE DAMAGES OR FOR LOSS, DAMAGE, OR EXPENSE, INCLUDING LOSS OF USE, PROFITS, REVENUE, OR GOODWILL, DIRECTLY OR INDIRECTLY ARISING FROM PURCHASER'S USE OR INABILITY TO USE THE PRODUCT, OR FOR LOSS OR DESTRUCTION OF OTHER PROPERTY OR FROM ANY OTHER CAUSE, EVEN IF MANUFACTURER HAS BEEN ADVISED OF THE POSSIBILITY OF SUCH DAMAGE.

THE MANUFACTURER SHALL HAVE NO LIABILITY FOR ANY DEATH, PERSONAL AND/OR BODILY INJURY AND/OR DAMAGE TO PROPERTY OR OTHER LOSS WHETHER DIRECT, INDIRECT, INCIDENTAL, CONSEQUENTIAL OR OTHERWISE, BASED ON A CLAIM THAT THE PRODUCT FAILED TO FUNCTION.

However, if the Manufacturer is held liable, whether directly or indirectly, for any loss or damage arising under this limited warranty, **THE MANUFACTURER'S MAXIMUM LIABILITY (IF ANY) SHALL NOT IN ANY CASE EXCEED THE PURCHASE PRICE OF THE PRODUCT**, which shall be fixed as liquidated damages and not as a penalty, and shall be the complete and exclusive remedy against the Manufacturer.

When accepting the delivery of the Product, the Purchaser agrees to the said conditions of sale and warranty and he recognizes having been informed of.

Some jurisdictions do not allow the exclusion or limitation of incidental or consequential damages, so these limitations may not apply under certain circumstances.

The Manufacturer shall be under no liability whatsoever arising out of the corruption and/or malfunctioning of any telecommunication or electronic equipment or any programs.

The Manufacturers obligations under this Warranty are limited solely to repair and/or replace at the Manufacturer's discretion any Product or part thereof that may prove defective. Any repair and/or replacement shall not extend the original Warranty period. The Manufacturer shall not be responsible for dismantling and/or reinstallation costs. To exercise this Warranty the Product must be returned to the Manufacturer freight pre-paid and insured. All freight and insurance costs are the responsibility of the Purchaser and are not included in this Warranty.

This warranty shall not be modified, varied or extended, and the Manufacturer does not authorize any person to act on its behalf in the modification, variation or extension of this warranty. This warranty shall apply to the Product only. All products, accessories or attachments of others used in conjunction with the Product, including batteries, shall be covered solely by their own warranty, if any. The Manufacturer shall not be liable for any damage or loss whatsoever, whether directly, indirectly, incidentally, consequentially or otherwise, caused by the malfunction of the Product due to products, accessories, or attachments of others, including batteries, used in conjunction with the Products. This Warranty is exclusive to the original Purchaser and is not assignable.

This Warranty is in addition to and does not affect your legal rights. Any provision in this warranty which is contrary to the Law in the state or country where the Product is supplied shall not apply.

Warning: The user must follow the Manufacturer's installation and operational instructions including testing the Product and its whole system at least once a week and to take all necessary precautions for his/her safety and the protection of his/her property.

1/08



W.E.E.E. Product Recycling Declaration

For information regarding the recycling of this product you must contact the company from which you originally purchased it. If you are discarding this product and not returning it for repair then you must ensure that it is returned as identified by your supplier. **This product is not to be thrown away with everyday waste.** Directive 2002/96/EC Waste Electrical and Electronic Equipment.



VISONIC LTD. (ISRAEL): P.O.B 22020 TEL-AVIV 61220 ISRAEL. PHONE: (972-3) 645-6789, FAX: (972-3) 645-6788
VISONIC INC. (U.S.A.): 65 WEST DUDLEY TOWN ROAD, BLOOMFIELD CT. 06002-1376. PHONE: (860) 243-0833, (800) 223-0020.
FAX: (860) 242-8094

VISONIC LTD. (UK): UNIT 6 MADINGLEY COURT CHIPPENHAM DRIVE KINGSTON MILTON KEYNES MK10 0BZ. TEL: (0870) 7300800
FAX: (0870) 7300801. TEL: (0870) 7300800 FAX: (0870) 7300801 **PRODUCT SUPPORT: (0870) 7300830**

VISONIC GmbH (D-A-CH): KIRCHFELDSTR. 118, D-40215 DÜSSELDORF, TEL.: +49 (0)211 600696-0, FAX: +49 (0)211 600696-19
VISONIC IBERICA: ISLA DE PALMA, 32 NAVE 7, POLIGONO INDUSTRIAL NORTE, 28700 SAN SEBASTIÁN DE LOS REYES, (MADRID), ESPAÑA.
TEL (34) 91659-3120, FAX (34) 91663-8468. www.visonic-iberica.es

INTERNET: www.visonic.com

©VISONIC LTD. 2010 MC-302 PG2 D-302412 (REV. 0, 11/10)



MADE IN ISRAEL