

Test Report of FCC Part 15 C for FCC Certificate

On Behalf of

Shenzhen SQT Electronics CO.,Ltd.

FCC ID: WOX-SMK-78507GL-K
Product Description: 2.4G Keyboard & Laser Mouse Combo(Keyboard Part)
Model No.: SMK-78507AGL
Supplementary Model No.: SMK-78503AGL,SMK-78312AGL (All Models just different with appearance)

Prepared for: Shenzhen SQT Electronics CO.,Ltd.
Block B4, Hengji industrial Park, Heyi Village, Sha jing Town, Baoan Area, Shenzhen, China

Prepared by: Bontek Compliance Testing Laboratory Ltd.
1/F, Block East H-3, OCT Eastern Ind. Zone, Qiaocheng East Road, Nanshan, Shenzhen, China
Tel: 86-755-86337020
Fax: 86-755-86337028

Report No.: BCT11AR-0046E-2

Issue Date: February 12, 2011

Test Date: January 20~ February 10, 2011

Test by:

Reviewed By:

Nie Quan

Nie Quan

Kevin Chi

Kevin Chi

TABLE OF CONTENTS

1. GENERAL INFORMATION..... 3

1.1 Client Information..... 3

1.2 Related Submittal(s) / Grant (s) 3

1.3 Test Methodology 3

1.4 Test Facility..... 4

2. SYSTEM TEST CONFIGURATION 5

2.1 EUT Configuration 5

2.2 EUT Exercise 5

2.3 General Test Procedures..... 5

2.4 List of Measuring Equipments..... 6

3. SUMMARY OF TEST RESULTS 8

4. TEST OF CONDUCTED EMISSION 9

4.1 Applicable Standard..... 9

4.2 Test Setup Diagram 9

5. BAND EDGES MEASUREMENT..... 10

5.1 Limit of Band Edges Measurement..... 10

5.2 EUT Setup 10

5.3 Test Procedure 11

5.4 Test Result..... 11

6. SPURIOUS EMISSIONS 14

6.1 Limit of Spurious Emissions..... 14

6.2 EUT Setup 15

6.3 Test Procedure 16

6.4 Spurious Emissions Test Result 16

7. ANTENNA REQUIREMENT..... 24

7.1 Standard Applicable..... 24

7.2 Antenna Connected Construction 24

1. GENERAL INFORMATION

1.1 Client Information

Applicant: **Shenzhen SQT Electronics CO.,Ltd.**
Address of applicant: Block B4, Hengji industrial Park, Heyi Village, Sha jing Town, Baoan Area, Shenzhen, China
Manufacturer: **Shenzhen SQT Electronics CO.,Ltd.**
Address of manufacturer: Block B4, Hengji industrial Park, Heyi Village, Sha jing Town, Baoan Area, Shenzhen, China

General Description of E.U.T

Items	Description
EUT Description:	2.4G Keyboard & Laser Mouse Combo(Keyboard Part)
Trade Name:	SQT
Model No.:	SMK-78507AGL
Supplementary Model No.:	SMK-78503AGL, SMK-78312AGL
Frequency Band:	2403 MHz ~ 2479 MHz
Number of Channels:	39
Channel Bandwidth:	2 MHz
Antenna Type:	Built-in Antenna
Rated Voltage:	3 V DC from battery

* The test data gathered are from the production sample provided by the manufacturer.

1.2 Related Submittal(s) / Grant (s)

This submittal(s) is a test report based on the Electromagnetic Interference (EMI) tests performed on the EUT. The EMI measurements were performed according to the measurement procedure described in ANSI C63.4 - 2009.

The tests were performed in order to determine compliance with Section 15.107 and 15.109 under the FCC Rules Part 15 Subpart B and Section 15.207, 15.209, 15.249 under the FCC Rules Part 15 Subpart C.

1.3 Test Methodology

Both conducted and radiated testing were performed according to the procedures in ANSI C63.4 - 2009, American National Standard for Methods of Measurement of Radio-Noise Emissions from Low-Voltage Electrical and Electronic Equipment in the range of 9 kHz to 40 GHz. Radiated testing was performed at an antenna to EUT distance 3 meters.

1.4 Test Facility

All measurement required was performed at laboratory of Bontek Compliance Testing Laboratory Ltd at 1/F, Block East H-3, OCT Eastern Ind. Zone, Qiaocheng East Road, Nanshan, Shenzhen, China.

The test facility is recognized, certified, or accredited by the following organizations:

FCC – Registration No.: 338263

Bontek Compliance Testing Laboratory Ltd. EMC Laboratory has been registered and fully described in a report filed with the (FCC) Federal Communications Commission. The acceptance letter from the FCC is maintained in our files. Registration 338263, March, 2008.

IC Registration No.: 7631A

The 3m alternate test site of Bontek Compliance Testing Laboratory Ltd. EMC Laboratory has been registered by Certification and Engineer Bureau of Industry Canada for the performance of with Registration NO.: 7631A on August 2009.

The facility also complies with the radiated and AC line conducted test site criteria set forth in ANSI C63.4-2009.

CNAS - Registration No.: L3923

Bontek Compliance Testing Laboratory Ltd. to ISO/IEC 17025:25 General Requirements for the Competence of Testing and Calibration Laboratories(CNAS-CL01 Accreditation Criteria for the Competence of Testing and Calibration Laboratories) for the competence in the field of testing. The acceptance letter from the CNAS is maintained in our files: Registration:L3923,February,2009.

TUV - Registration No.: UA 50145371-0001

Bontek Compliance Testing Laboratory Ltd. An assessment of the laboratory was conducted according to the "Procedures and Conditions for EMC Test Laboratories"with reference to EN ISO/IEC 17025 by a TUV Rheinland auditor. Audit Report NO. 17010783-001

2. SYSTEM TEST CONFIGURATION

The tests documented in this report were performed in accordance with ANSI C63.4-2009 and FCC CFR 47 Part 15 Subpart C.

2.1 EUT Configuration

The EUT configuration for testing is installed on RF field strength measurement to meet the Commissions requirement and operating in a manner that intends to maximize its emission characteristics in a continuous transmitting application.

2.2 EUT Exercise

The calibrated antennas used to sample the radiated field strength are mounted on a non-conductive, motorized antenna mast 3 or 10 meters from the leading edge of the turntable.

2.3 General Test Procedures

Conducted Emissions The EUT is placed on the turntable, which is 0.8 m above ground plane. According to the requirements in Section 7.1 of ANSI C63.4-2009. Conducted emissions from the EUT measured in the frequency range between 0.15 MHz and 30MHz using CISPR Quasi-Peak detector mode. But the EUT is powered by DC 3V of battery, this test is not applicable.

Radiated Emissions The EUT is placed on a turntable, which is 0.8 m above ground plane. The turntable shall rotate 360 degrees to determine the position of maximum emission level. EUT is set 3m away from the receiving antenna, which varied from 1m to 4m to find out the highest emission. And also, each emission was to be maximized by changing the polarization of receiving antenna both horizontal and vertical. In order to find out the maximum emissions, exploratory radiated emission measurements were made according to the requirements in Section 13.1.4.1 of ANSI C63.4-2009.

2.4 List of Measuring Equipments

Test equipments list of SHENZHEN BONTEK ELECTRONIC TECHNOLOGY CO., LTD. .

No.	Instrument no.	Equipment	Manufacturer	Model No.	S/N	Calibration Date	Calibration Due Date
1	BCT-EMC001	EMI Test Receiver	R&S	ESCI	100687	2010-4-14	2011-4-13
2	BCT-EMC002	EMI Test Receiver	R&S	ESPI	100097	2010-4-14	2011-4-13
3	BCT-EMC003	Amplifier	HP	8447D	1937A02492	2010-4-14	2011-4-13
4	BCT-EMC004	Single Power Conductor Module	FCC	FCC-LISN-5-50-1-01-CISPR25	7101	2010-4-14	2011-4-13
5	BCT-EMC005	Single Power Conductor Module	FCC	FCC-LISN-5-50-1-01-CISPR25	7102	2010-4-14	2011-4-13
6	BCT-EMC006	Power Clamp	SCHWARZBECK	MDS-21	3812	2010-4-14	2011-4-13
7	BCT-EMC007	Positioning Controller	C&C	CC-C-1F	MF7802113	N/A	N/A
8	BCT-EMC008	Electrostatic Discharge Simulator	TESEQ	NSG437	125	2010-4-14	2011-4-13
9	BCT-EMC009	Fast Transient Burst Generator	SCHAFFNER	MODULA6150	34572	2010-4-14	2011-4-13
10	BCT-EMC010	Fast Transient Noise Simulator	Noiseken	FNS-105AX	31485	2010-4-14	2011-4-13
11	BCT-EMC011	Color TV Pattern Generator	PHILIPS	PM5418	TM209947	N/A	N/A
12	BCT-EMC012	Power Frequency Magnetic Field Generator	EVERFINE	EMS61000-8K	608002	2010-4-14	2011-4-13
13	BCT-EMC013	N/A	N/A	N/A	N/A	N/A	N/A
14	BCT-EMC014	Capacitive Coupling Clamp	TESEQ	CDN8014	25096	2010-4-14	2011-4-13
15	BCT-EMC015	High Field Biconical Antenna	ELECTRO-METRICS	EM-6913	166	2010-4-14	2012-4-13
16	BCT-EMC016	Log Periodic Antenna	ELECTRO-METRICS	EM-6950	811	2010-4-14	2012-4-13
17	BCT-EMC017	Remote Active Vertical Antenna	ELECTRO-METRICS	EM-6892	304	2010-4-14	2012-4-13
18	BCT-EMC018	TRILOG Broadband Test-Antenna	SCHWARZBECK	VULB9163	9163-324	2010-4-14	2012-4-13
19	BCT-EMC019	Horn Antenna	SCHWARZBECK	BBHA9120A	B08000991-0001	2010-4-14	2012-4-13
20	BCT-EMC020	Teo Line Single Phase Module	SCHWARZBECK	NSLK8128	D-69250	2010-4-14	2011-4-13
21	BCT-EMC021	10dB attenuator	SCHWARZBECK	MTAIMP-136	R65.90.0001#06	2010-4-14	2011-4-13

22	BCT-EMC022	Electric bridge	Zentech	100 LCR METER	803024	N/A	N/A
23	BCT-EMC023	RF Current Probe	FCC	F-33-4	80	2010-4-14	2011-4-13
24	BCT-EMC024	SIGNAL GENERATOR	HP	8647A	3349A02296	2010-4-14	2011-4-13
25	BCT-EMC025	MICROWAVE AMPLIFIER	HP	8349B	2627A00994	2010-4-14	2011-4-13
26	BCT-EMC026	Triple-Loop Antenna	EVERFINE	LLA-2	607004	2010-4-14	2011-4-13
27	BCT-EMC027	CDN	FRANKONIA	M2+M3	A3027019	2010-10-20	2011-10-19
28	BCT-EMC028	6dB Attenuator	FRANKONIA	75-A-FFN-06	1001698	2010-10-20	2011-10-19
29	BCT-EMC029	EMV-Mess-Systeme GMBH	FRANKONIA	FLL-75	1020A1109	2010-10-20	2011-10-19
30	BCT-EMC030	EM Injection Clamp	FCC	F-203I-13mm	91536	2010-10-20	2011-10-19
31	BCT-EMC031	9KHz-2.4GHz Signal generator	MARCONI INSTRUMENTS	2024	112260/042	2010-10-20	2011-10-19

3. SUMMARY OF TEST RESULTS

EUT Fundamental Frequency	FCC Rules	Description of Test	Result
2.403~2.479 GHz	15.207	Disturbance Voltage at The Mains Terminals	N/A , without AC main
	15.249	Band Edges Measurement	Pass
	15.249	Spurious Emission	Pass
	15.203	Antenna Requirement	Pass

4. TEST OF CONDUCTED EMISSION

4.1 Applicable Standard

Section 15.207: For a Low-power Radio-frequency Device is designed to be connected to the AC power line, the radio frequency voltage that is conducted back onto the AC power line on any frequency or frequencies within the band 150 kHz to 30 MHz shall not exceed below limits table.

Frequency Range (MHz)	Limits (dBuV)	
	Quasi-Peak	Average
0.150~0.500	66~56	56~46
0.500~5.000	56	46
5.000~30.00	60	50

4.2 Test Setup Diagram

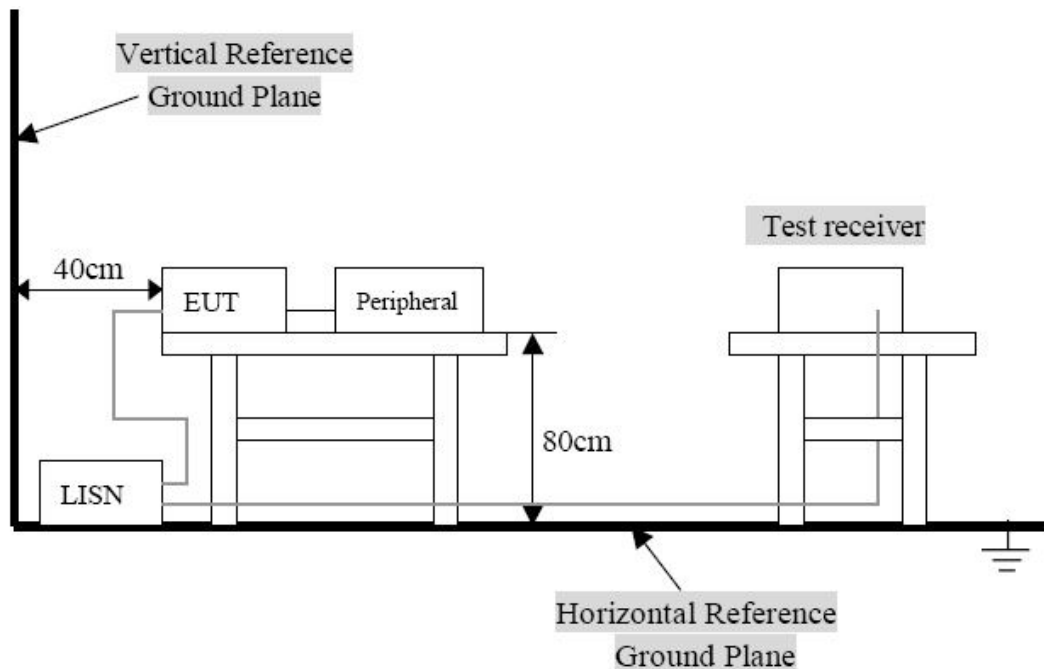

Remark: 1. The setup of EUT is according with per ANSI C63.4-2009 measurement procedure. The specification used was with the FCC 15.207 limits.

2. The EUT was charged on the base, and the base was connected to a 120 VAC/ 60Hz power source.

Notes: The EUT is powered by DC 3V from battery, without AC mains, this test is unapplicable.

5. BAND EDGES MEASUREMENT

5.1 Limit of Band Edges Measurement

1. In the above emission table, the tighter limit applies at the band edges.
2. As shown in Section 15.35(b), for frequencies above 1000 MHz, the above field strength limits in paragraphs (a) and (b) of this section are based on average limits. However, the peak field strength of any emission shall not exceed the maximum permitted average limits specified above by more than 20 dB under any condition of modulation. For point-to-point operation under paragraph (b) of this section, the peak field strength shall not exceed 2500 millivolts/meter at 3 meters along the antenna azimuth.

Frequency (MHz)	Field Strength ($\mu\text{V/m}$ at 3-meter)	Field Strength ($\text{dB}\mu\text{V/m}$ at 3-meter)
30-88	100	40
88-216	150	43.5
216-960	200	46
Above 960	500	54

Note: (1) The tighter limit shall apply at the edge between two frequency bands.

- (2) The emission limits shown in the above table are based on measurement employing a CISPR quasi-peak detector and above 1000MHz are based on measurements employing an average detector.

5.2 EUT Setup

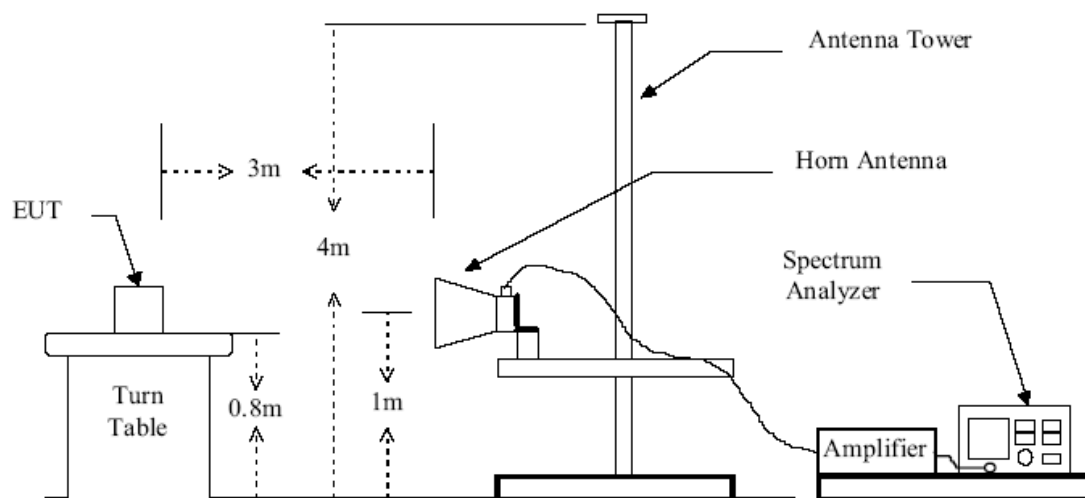

Figure 2 : Frequencies measured above 1 GHz configuration

5.3 Test Procedure

Maximizing procedure was performed on the highest emissions to ensure that the EUT complied with all installation combinations.

- 1). Configure the EUT according to ANSI C63.4:2009.
- 2). The EUT was placed on the top of the turntable 0.8 meter above ground.
- 3). The receiving antenna was placed 3 meters far away from the turntable.
- 4). The turntable was rotated by 360 degrees to determine the position of the highest radiation.
- 5). The height of the broadband receiving antenna was varied between one meter and four meters above ground to find the maximum emission field strength of both horizontal and vertical polarization. For each suspected emission, the antenna tower was scanned (from 1 M to 4 M) and then the turntable was rotated (from 0 degree to 360 degrees) to find the maximum reading.

5.4 Test Result

Temperature (°C) : 22~23	EUT: 2.4G Keyboard& Laser Mouse Combo (Keyboard Part)
Humidity (%RH) : 50~54	M/N: SMK-78507AGL
Barometric Pressure (mbar) : 950~1000	Operation Condition: Continuous transmitting

Low Channel (2.403GHz):

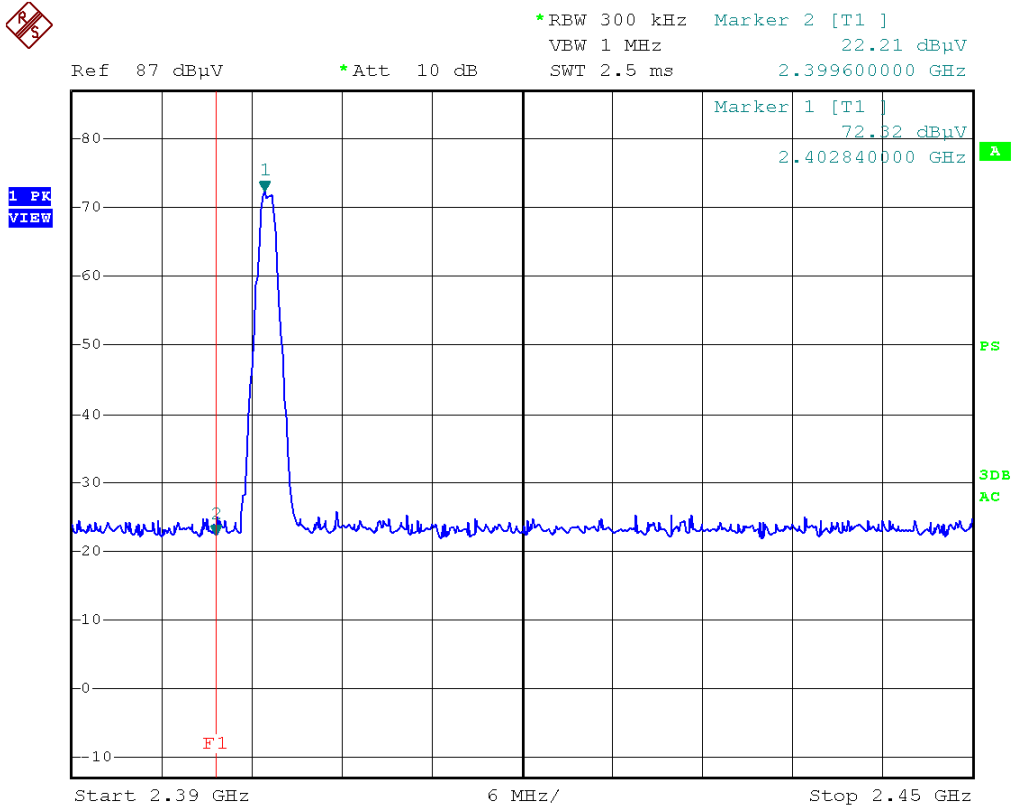

High Channel (2.479GHz):

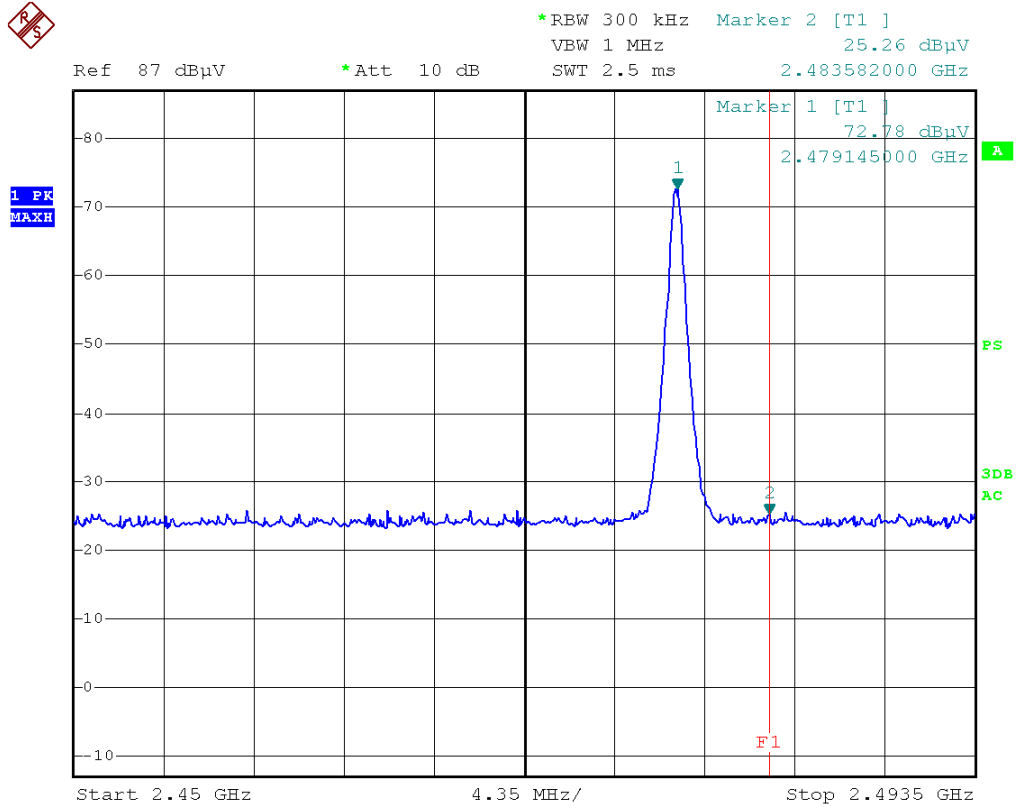

6. SPURIOUS EMISSIONS

6.1 Limit of Spurious Emissions

1. In the section 15.249(a): Except as provided in paragraph (b) of this section, the field strength of emissions from intentional radiators operated within these frequency bands shall comply with the following:
2. Except as provided elsewhere in this Subpart, the emissions from an intentional radiator shall not exceed the field strength levels specified in the following table:

Fundamental Frequency (MHz)	Field Strength of Fundamental Field Strength (mV/m)	Field Strength of Harmonics ($\mu\text{V/m}$)
902-928 MHz	50	500
2400 - 2483.5 MHz	50	500
5725 - 5875 MHz	50	500
24.0 - 24.25 GHz	250	2500

Frequency (MHz)	Field Strength ($\mu\text{V/m}$)	Measurement Distance (m)
30-88	100*	3
88-216	150*	3
216-960	200*	3
Above 960	500	3

Remark: Except as provided in paragraph (g), fundamental emissions from intentional radiators operating under this Section shall not be located in the frequency bands 54-72 MHz, 76-88 MHz, 174-216 MHz or 470-806 MHz. However, operation within these frequency bands is permitted under other sections of this Part, e.g., Sections 15.231 and 15.241.

3. In the above emission table, the tighter limit applies at the band edges.

Frequency (MHz)	Field Strength ($\mu\text{V/m}$ at 3-meter)	Field Strength ($\text{dB}\mu\text{V/m}$ at 3-meter)
30-88	100	40
88-216	150	43.5
216-960	200	46
Above 960	500	54

6.2 EUT Setup

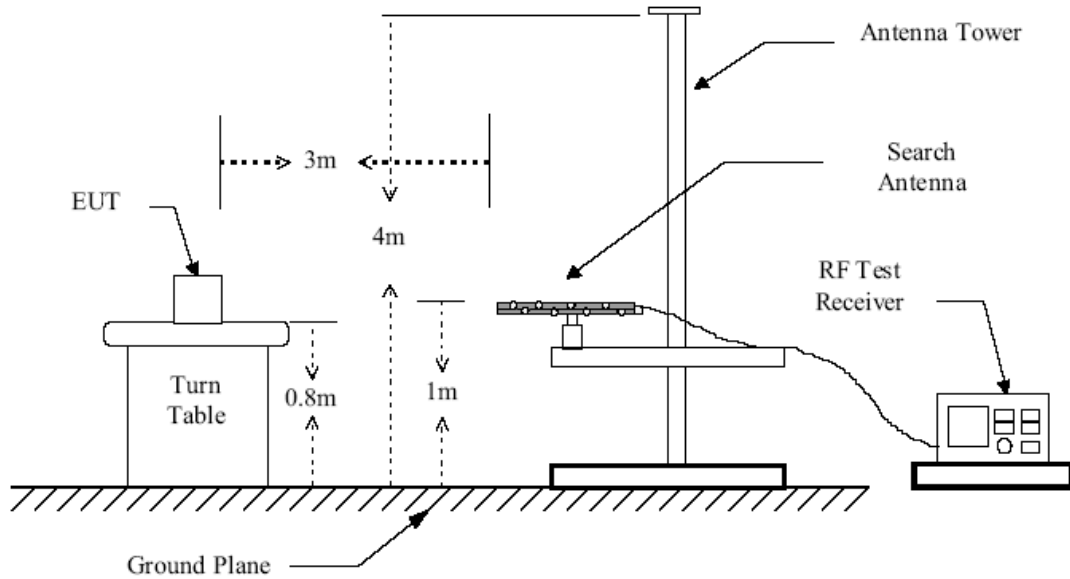

Figure 1 : Frequencies measured below 1 GHz configuration

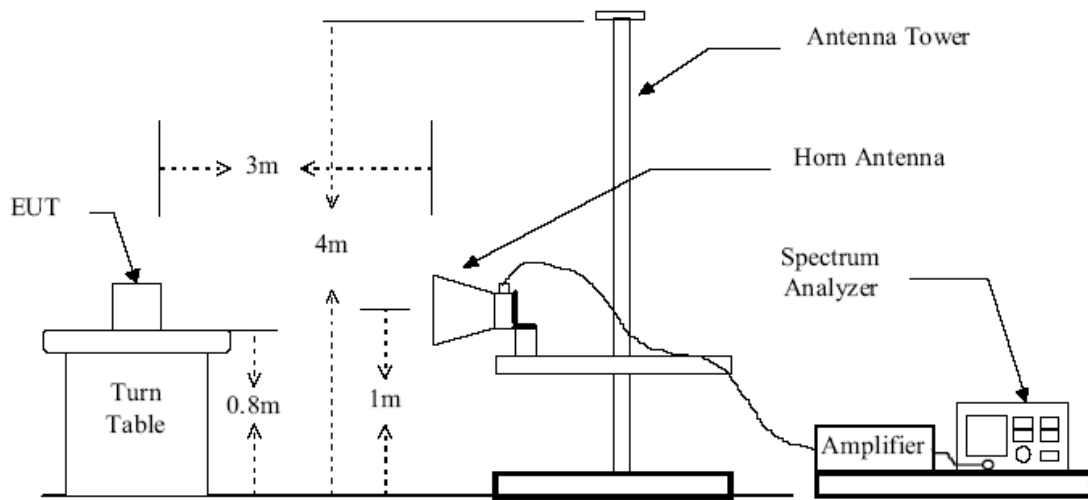

Figure 2 : Frequencies measured above 1 GHz configuration

6.3 Test Procedure

Maximizing procedure was performed on the highest emissions to ensure that the EUT complied with all installation combinations.

- 1). Configure the EUT according to ANSI C63.4:2009.
- 2). The EUT was placed on the top of the turntable 0.8 meter above ground.
- 3). The receiving antenna was placed 3 meters far away from the turntable.
- 4). The turntable was rotated by 360 degrees to determine the position of the highest radiation.
- 5). The height of the broadband receiving antenna was varied between one meter and four meters above ground to find the maximum emission field strength of both horizontal and vertical polarization. For each suspected emission, the antenna tower was scanned (from 1 M to 4 M) and then the turntable was rotated (from 0 degree to 360 degrees) to find the maximum reading.

6.4 Spurious Emissions Test Result

Temperature (°C) : 22~23	EUT: 2.4G Keyboard & Laser Mouse Combo (Keyboard Part)
Humidity (%RH) : 50~54	M/N: SMK-78507AGL
Barometric Pressure (mbar) : 950~1000	Operation Condition: Continuous transmitting

The worst Spurious Emission Data Below 1GHz:

EUT: 2.4G Keyboard&Laser Mouse Combo(Keyboard Part)
M/N: SMK-78507AGL
Operating Condition: Continuous transmitting
Test Site: 3m CHAMBER
Operator: Chen
Test Specification: DC 3V
Comment: Polarization: Horizontal
Tem:25°C Hum:50%

SWEEP TABLE: "test (30M-1G)"

Short Description:		Field Strength			
Start	Stop	Detector	Meas. Time	IF Bandw.	Transducer
Frequency	Frequency				
30.0 MHz	1.0 GHz	MaxPeak	Coupled	100 kHz	VULB9163 NEW

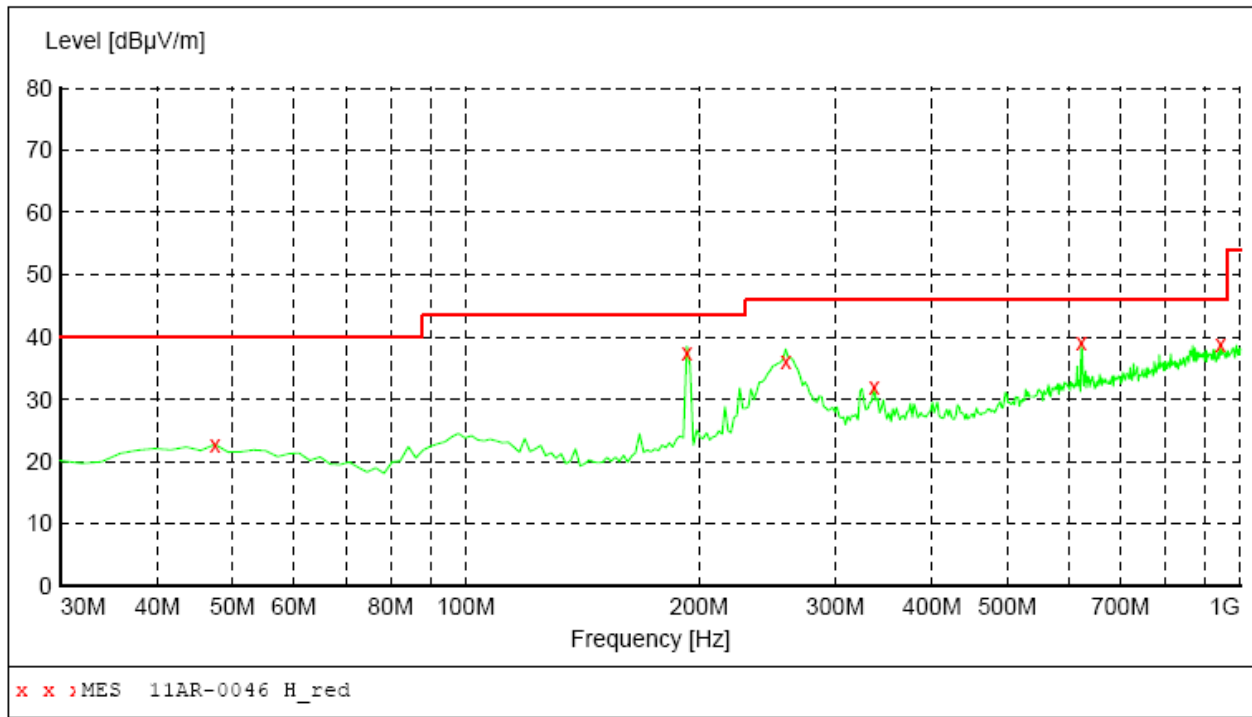

MEASUREMENT RESULT: "11AR-0046 H_red"

1/13/2011 22:14

Frequency MHz	Level dBµV/m	Transd dB	Limit dBµV/m	Margin dB	Det.	Height cm	Azimuth deg	Polarization
47.460000	22.70	15.8	40.0	17.3	QP	100.0	0.00	HORIZONTAL
192.960000	37.50	16.1	43.5	6.0	QP	300.0	0.00	HORIZONTAL
258.920000	36.10	17.3	46.0	9.9	QP	100.0	0.00	HORIZONTAL
336.520000	31.90	20.0	46.0	14.1	QP	100.0	0.00	HORIZONTAL
623.640000	39.30	26.7	46.0	6.7	QP	100.0	0.00	HORIZONTAL
941.800000	39.00	31.7	46.0	7.0	QP	100.0	0.00	HORIZONTAL

The worst Spurious Emission Data Below 1GHz:

EUT: 2.4G Keyboard&Laser Mouse Combo(Keyboard Part)
M/N: SMK-78507AGL
Operating Condition: Continuous transmitting
Test Site: 3m CHAMBER
Operator: Chen
Test Specification: DC 3V
Comment: Polarization: Vertical
Tem:25°C Hum:50%

SWEEP TABLE: "test (30M-1G)"

Short Description:		Field Strength			
Start	Stop	Detector	Meas. Time	IF Bandw.	Transducer
Frequency	Frequency				
30.0 MHz	1.0 GHz	MaxPeak	Coupled	100 kHz	VULB9163 NEW

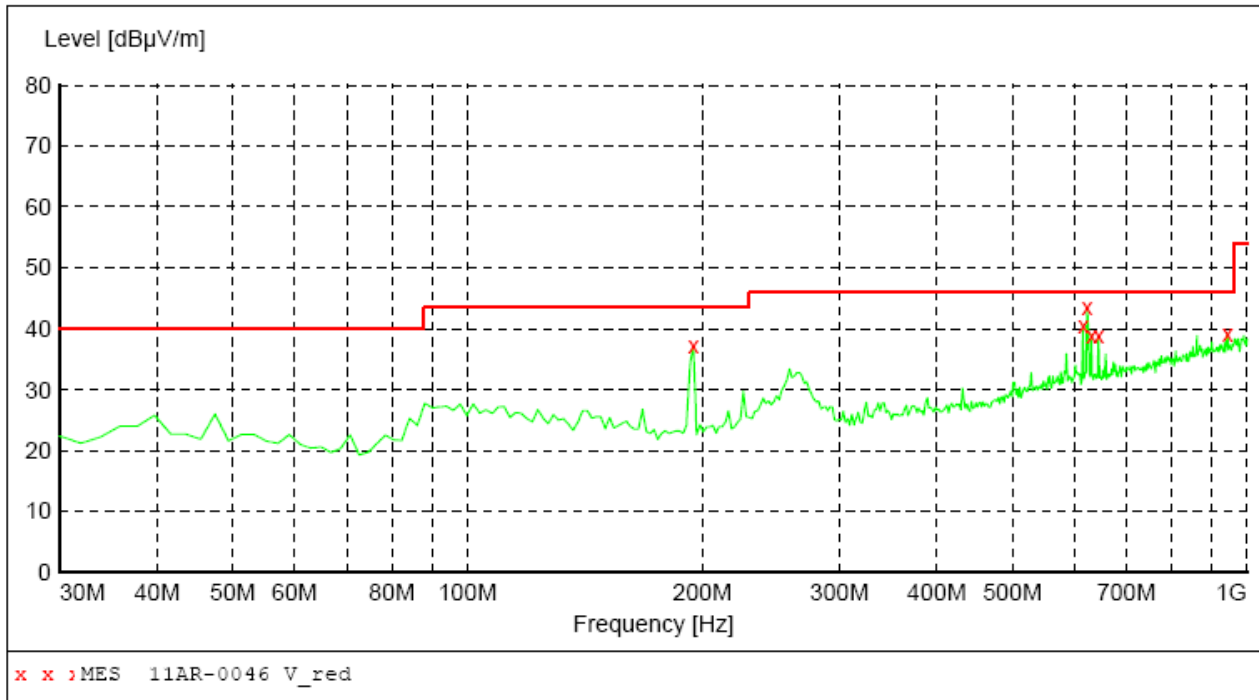

MEASUREMENT RESULT: "11AR-0046 V_red"

1/13/2011 22:13

Frequency MHz	Level dBµV/m	Transd dB	Limit dBµV/m	Margin dB	Det.	Height cm	Azimuth deg	Polarization
194.900000	37.20	16.1	43.5	6.3	QP	100.0	0.00	VERTICAL
615.880000	40.60	26.6	46.0	5.4	QP	100.0	0.00	VERTICAL
623.640000	43.60	26.7	46.0	2.4	QP	100.0	0.00	VERTICAL
631.400000	39.00	26.8	46.0	7.0	QP	100.0	0.00	VERTICAL
644.980000	38.80	26.9	46.0	7.2	QP	100.0	0.00	VERTICAL
943.740000	39.30	31.7	46.0	6.7	QP	100.0	0.00	VERTICAL

The worst Spurious Emission Data above 1GHz of horizontal

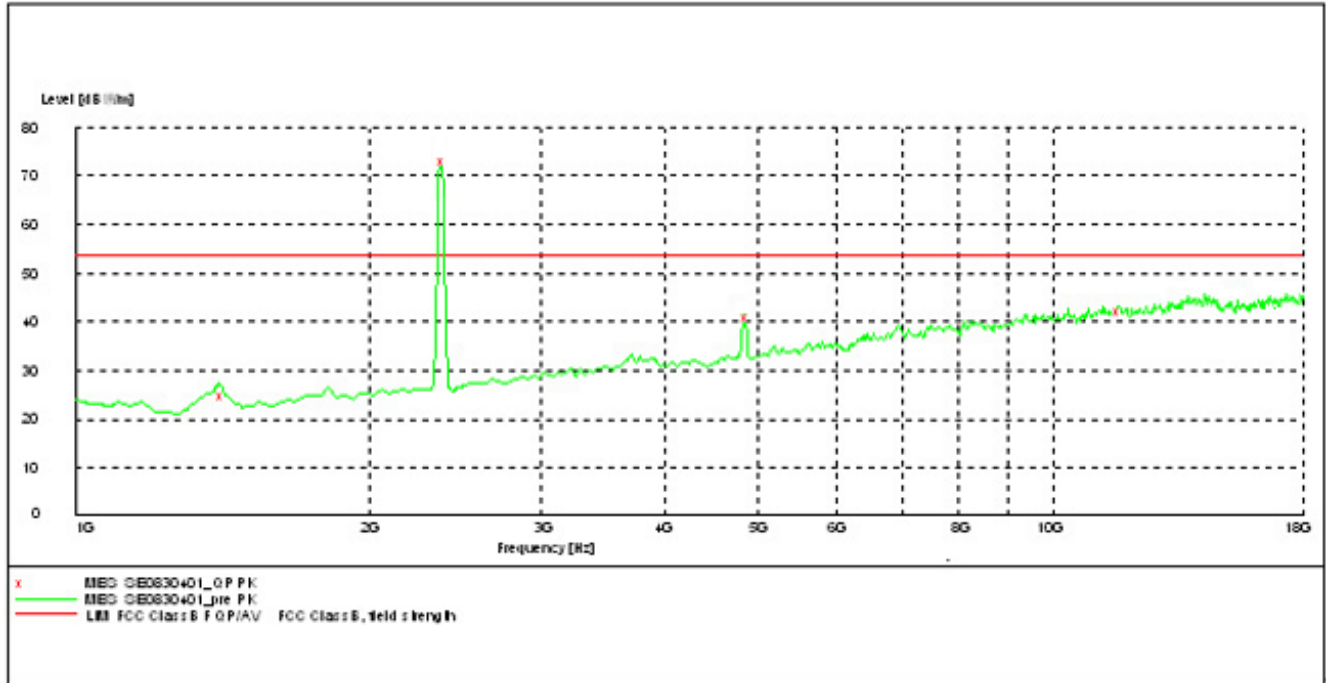

MEASUREMENT RESULT:

Frequency MHz	Level dB μ V/m	Transd dB	Limit dB μ V/m	Margin dB	Det.	Height cm	Azimuth deg	Polarization
2403.010000	75.00	31.5	84.0	9.0	AV	100.0	0.00	HORIZONTAL
4806.220000	35.10	14.7	44.0	8.9	AV	100.0	0.00	HORIZONTAL

The worst Spurious Emission Data above 1GHz of Vertical

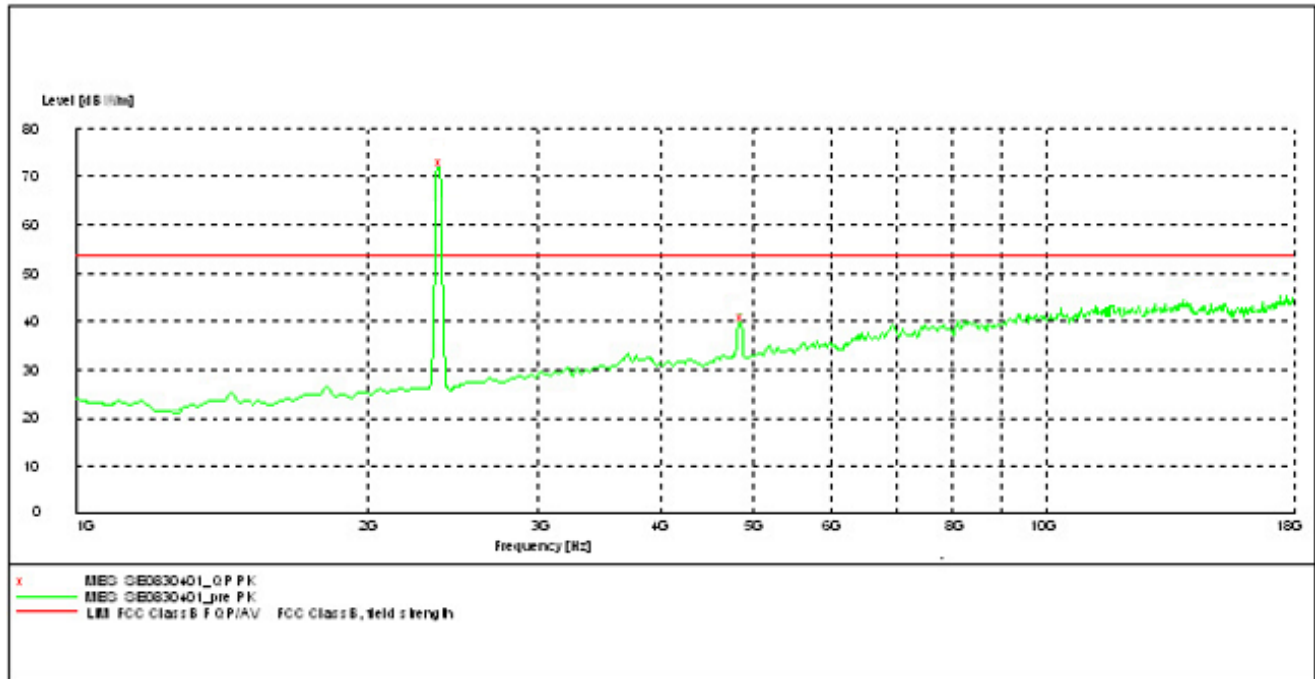

MEASUREMENT RESULT:

Frequency MHz	Level dB μ V/m	Transd dB	Limit dB μ V/m	Margin dB	Det.	Height cm	Azimuth deg	Polarization
2403.020000	72.20	31.2	84.0	11.9	AV	100.0	0.00	VERTICAL
4806.260000	41.60	32.3	44.0	2.8	AV	100.0	0.00	VERTICAL

The result of Field Strength of Fundamental Field Strength

Low Channel:

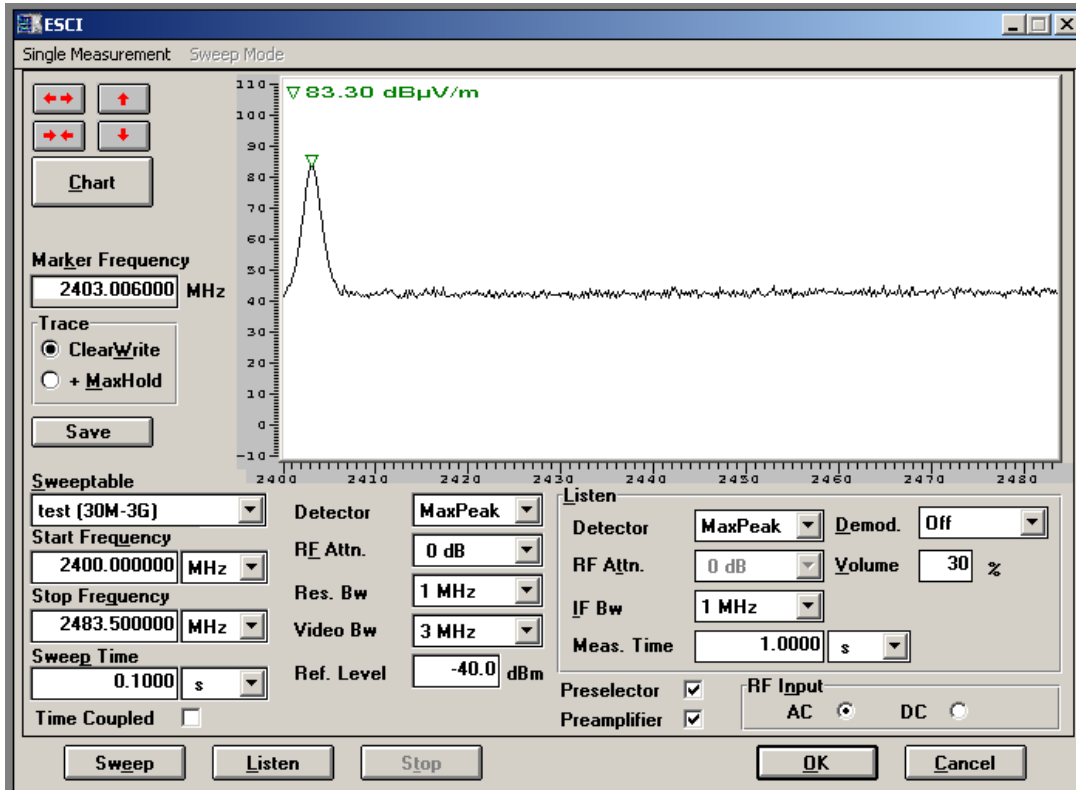

Remark:: Field Strength of Fundamental Field Strength of the EUT is 83.30dBµV/m , is lower than 50mv/m(94 dBµV/m), complies with limit of section 15.249(a) ,and the result is pass.

Middle Channel:

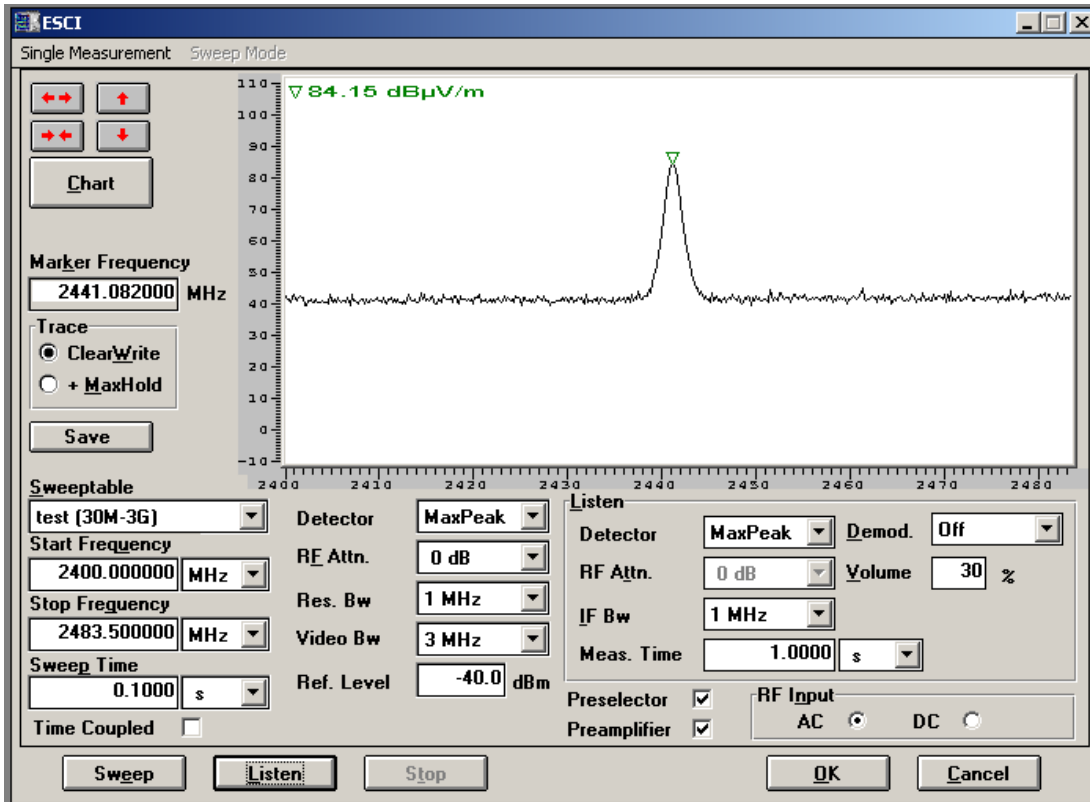

Remark:: Field Strength of Fundamental Field Strength of the EUT is 84.15dBµV/m , is lower than 50mv/m(94 dBµV/m), complies with limit of section 15.249(a) ,and the result is pass.

High Channel:

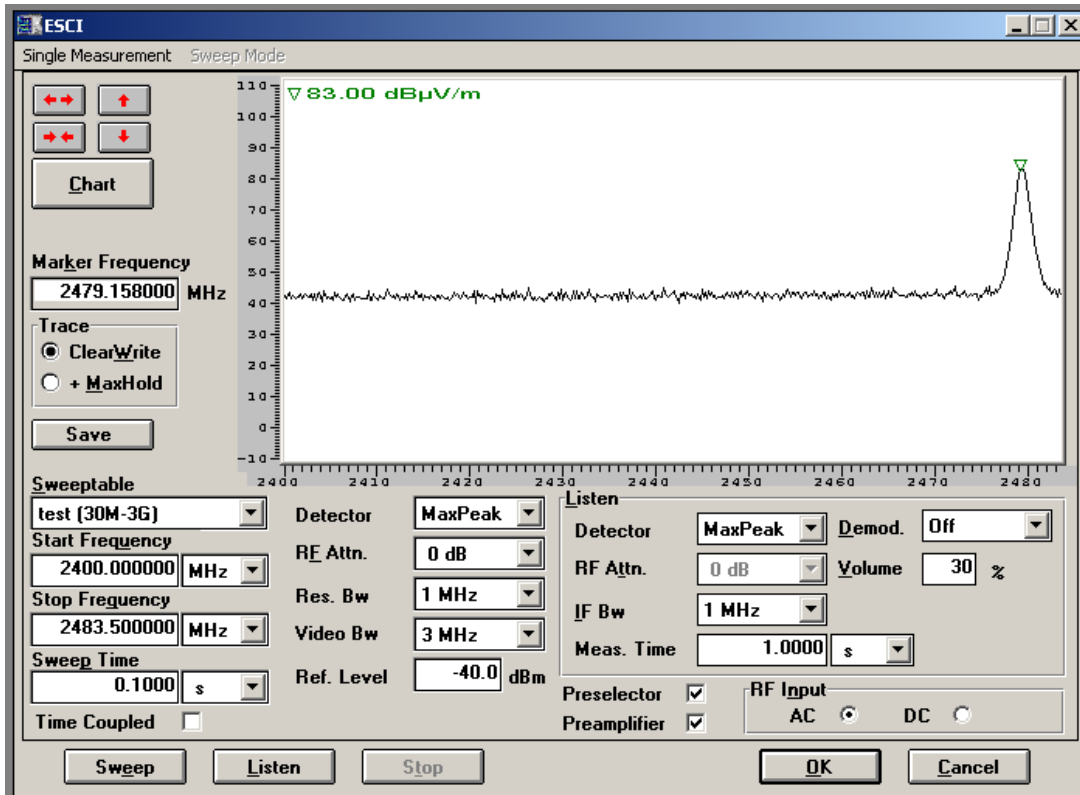

Remark:: Field Strength of Fundamental Field Strength of the EUT is 83.00dBμV/m , is lower than 50mv/m(94 dBμV/m), complies with limit of section 15.249(a) ,and the result is pass.

7. ANTENNA REQUIREMENT

7.1 Standard Applicable

Section 15.203:

An intentional radiator shall be designed to ensure that no antenna other than that furnished by the responsible party shall be used with the device. The use of a permanently attached antenna or of an antenna that uses a unique coupling to the intentional radiator shall be considered sufficient to comply with the provisions of this Section. The manufacturer may design the unit so that a broken antenna can be replaced by the user, but the use of a standard antenna jack or electrical connector is prohibited.

7.2 Antenna Connected Construction

The antenna connector is designed with permanent attachment and no consideration of replacement.