

# FCC RADIO TEST REPORT

The device described below is tested by Dongguan Nore Testing Center Co., Ltd. to determine the maximum emission levels emanating from the device, the severe levels which the device can endure and E.U.T.'s performance criterion. The test results, data evaluation, test procedures, and equipment of configurations shown in this report were made in accordance with the procedures in ANSI C63.10(2013).

Applicant : Vornado Air LLC  
Address : 415 East 13th Street, Andover, KS 67002, USA  
Manufacturer/ Factory : Foshan Shunde Toppin Electrical Technology Co., Ltd  
Address : No.7 Chaogui Road, Hi-Tech Area, Ronggui, Shunde District, Foshan  
Guangdong, China  
E.U.T. : Crib Sensor Remote  
Brand Name : Vornado  
Model No. : SENSEA  
FCC ID : WOT-SENSA  
Measurement Standard : FCC PART 15.231  
Date of Receiver : September 07, 2020  
Date of Test : September 07, 2020 to September 29, 2020  
Date of Report : November 10, 2020

This Test Report is Issued Under the Authority of :

Prepared by



Rose Hu / Engineer



Iori Fan / Authorized Signatory

This test report is for the customer shown above and their specific product only. This report applies to above tested sample only and shall not be reproduced in part without written approval of Dongguan Nore Testing Center Co., Ltd.

---

## Table of Contents

<b>1. GENERAL INFORMATION .....</b>	<b>4</b>
1.1 PRODUCT DESCRIPTION FOR EQUIPMENT UNDER TEST .....	4
1.2 RELATED SUBMITTAL(S) / GRANT (S) .....	5
1.3 TEST METHODOLOGY .....	5
1.4 EQUIPMENT MODIFICATIONS .....	5
1.5 SUPPORT DEVICE .....	5
1.6 TEST FACILITY AND LOCATION .....	6
1.7 SUMMARY OF TEST RESULTS .....	7
1.8 DEVIATIONS AND ABNORMALITIES FROM STANDARD CONDITIONS.....	7
<b>2. RADIATED EMISSION TEST .....</b>	<b>8</b>
2.1 TEST SET-UP (BLOCK DIAGRAM OF CONFIGURATION) .....	8
2.2 MEASUREMENT PROCEDURE .....	9
2.3 LIMIT .....	9
2.4 MEASUREMENT RESULTS .....	11
<b>3. OCCUPIED BANDWIDTH .....</b>	<b>16</b>
3.1 MEASUREMENT PROCEDURE .....	16
3.2 TEST SET-UP (BLOCK DIAGRAM OF CONFIGURATION) .....	16
3.3 LIMIT .....	16
3.4 MEASUREMENT RESULTS .....	16
<b>4 TRANSMISSION TIME .....</b>	<b>17</b>
4.1 MEASUREMENT PROCEDURE .....	17
4.2 TEST SET-UP (BLOCK DIAGRAM OF CONFIGURATION) .....	17
4.3 LIMIT .....	17
4.4 MEASUREMENT RESULTS .....	17
<b>5. ANTENNA APPLICATION .....</b>	<b>21</b>
5.1 ANTENNA REQUIREMENT.....	21
5.2 MEASUREMENT RESULTS .....	21
<b>6. TEST EQUIPMENT LIST.....</b>	<b>22</b>



## 1.GENERAL INFORMATION

### 1.1 Product Description for Equipment under Test

E.U.T.	:	Crib Sensor Remote
Main Model Name	:	SENSA
Additional Model Name	:	N/A
Brand Name	:	Vornado
Rating	:	DC 3V (From 1.5V AA Battery *2)
Test Voltage	:	DC 3V
Hardware Version	:	V1.0
Software Version	:	V1.0
S/N	:	SENSA001
Description of Model Difference	:	N/A
Note	:	N/A

### Technical parameters (315MHz Transmitter )

Declaring the Frequency	:	315MHz
Modulation	:	GFSK
Antenna Type	:	PCB Antenna
Antenna Gain	:	0 dBi
Channelized system/ Non-channelized system	:	Non-channelized system

## **1.2 Related Submittal(s) / Grant (s)**

This submittal(s) (test report) is intended for FCC ID: WOT-SENSA filing to comply with Section 15.231 of the FCC Part 15, Subpart C Rule.

## **1.3 Test Methodology**

The radiated emission measurement was performed according to the procedures in ANSI C63.10 (2013). Radiated emission measurement was performed in semi-anechoic chamber. For radiated emission measurement, preliminary scans were performed in the semi-anechoic chamber only to determine the worst case modes. All radiated tests were performed at an antenna to EUT distance of 3 meters.

## **1.4 Equipment Modifications**

Not available for this EUT intended for grant.

## **1.5 Support Device**

N/A

## 1.6 Test Facility and Location

### Site Description

EMC Lab : Listed by CNAS, August 13, 2018  
The certificate is valid until August 13, 2024  
The Laboratory has been assessed and proved to be in compliance with CNAS/CL01  
The Certificate Registration Number is L5795.

Listed by A2LA, November 01, 2017  
The certificate is valid until December 31, 2021  
The Laboratory has been assessed and proved to be in compliance with ISO17025  
The Certificate Registration Number is 4429.01

Listed by FCC, November 06, 2017  
The Designation Number is CN1214  
Test Firm Registration Number: 907417

Listed by Industry Canada, June 08, 2017  
The Certificate Registration Number is 46405-9743A

Name of Firm : Dongguan Nore Testing Center Co., Ltd.  
(Dongguan NTC Co., Ltd.)

Site Location : Building D, Gaosheng Science and Technology Park,  
Hongtu Road, Nancheng District, Dongguan City,  
Guangdong Province, China

### 1.7 Summary of Test Results

FCC Rules	Description Of Test	Result
§15.207	AC Power Conducted Emission	N/A <sup>see note 2</sup>
§15.231&15.209	Radiated Emission	Compliant
§15.231(c)	Occupied bandwidth	Compliant
§15.231(e)	Transmission time	Compliant
§15.203	Antenna Requirement	Compliant

- Note: 1. The EUT has been tested as an independent unit. And Continual transmitting in maximum power.
2. This product will not be connected to the AC mains during normal use, therefore the AC Power Conducted Emission project test is not applicable.
3. The EUT operating multiple positions, therefore the EUT shall be performed three orthogonal planes. The worst plane is Z.

Example:

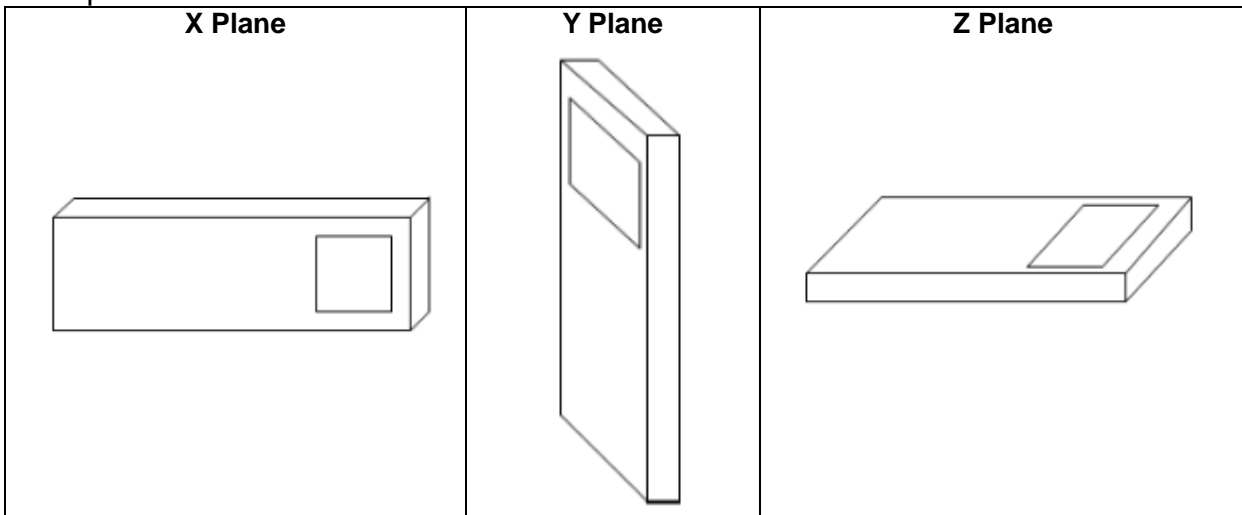

### 1.8 Deviations and Abnormalities from Standard Conditions

No additions, deviations and exclusions from the standard.

## 2. Radiated Emission Test

### 2.1 Test SET-UP (Block Diagram of Configuration)

(1) Radiated Emission Test Set-Up, Frequency Below 30MHz and 30-1000MHz.

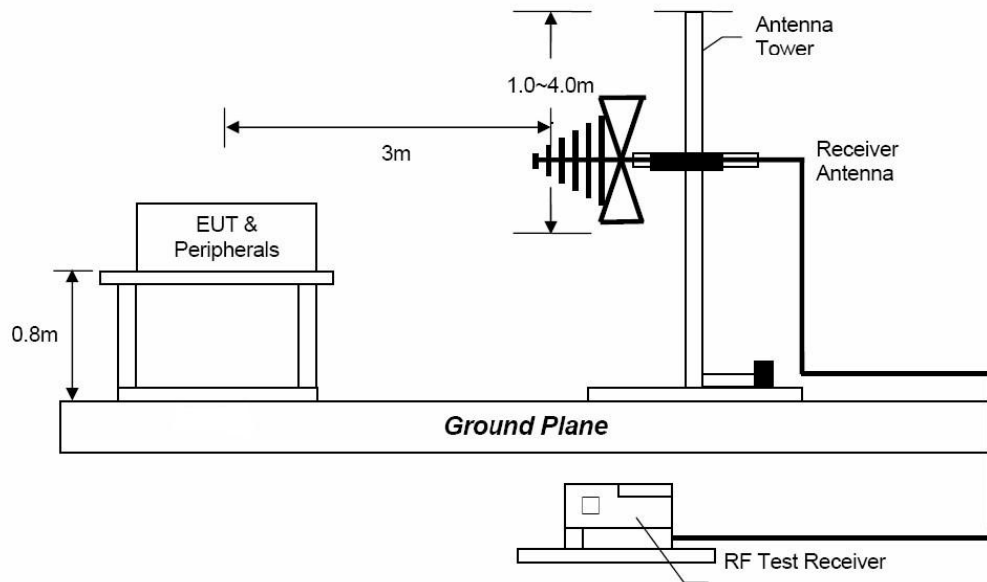
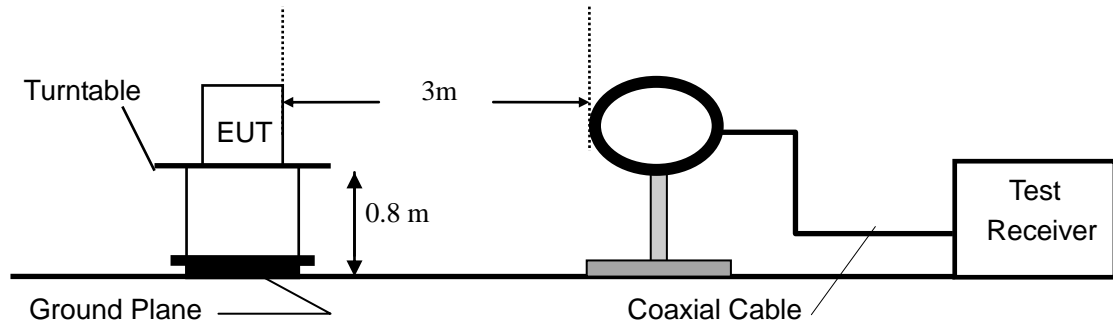

(2) Radiated Emission Test Set-Up, Frequency above 1GHz

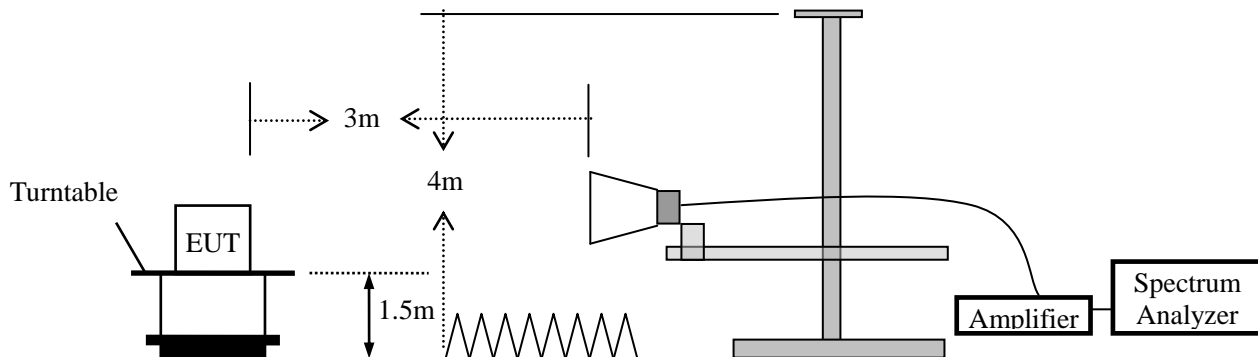



## 2.2 Measurement Procedure

- a. Blow 1GHz, the EUT was placed on the top of a rotating table 0.8 meters above the ground at a 3 meter semi- anechoic chamber room.
- b. For the radiated emission test above 1GHz:  
 The EUT was placed on the top of a rotating table 1.5 meters above the ground at a 3 meter full anechoic chamber room. The table was rotated 360 degrees to determine the position of the highest radiation. Place the measurement antenna away from each area of the EUT determined to be a source of emissions at the specified measurement distance, while keeping the measurement antenna aimed at the source of emissions at each frequency of significant emissions, with polarization oriented for maximum response. The measurement antenna may have to be higher or lower than the EUT, depending on the radiation pattern of the emission and staying aimed at the emission source for receiving the maximum signal. The final measurement antenna elevation shall be that which maximizes the emissions. The measurement antenna elevation for maximum emissions shall be restricted to a range of heights of from 1 m to 4 m above the ground or reference ground plane.
- c. The EUT was set 3 meters away from the interference-receiving antenna, which was mounted on the top of a variable-height antenna tower.
- d. The height of antenna is varied from one meter to four meters above the ground to determine the maximum value of the field strength. Both horizontal and vertical polarizations of the antenna are set to make the measurement.
- e. For each suspected emission, the EUT was arranged to its worst case and then the antenna was tuned to heights from 1 meter to 4 meters and the rotatable table was turned from 0 degrees to 360 degrees to find the maximum reading. The test-receiver system was set to peak detect function and specified bandwidth with maximum hold mode.
- f. A Quasi-peak measurement was then made for that frequency point for below 1GHz test. PK and AV for above 1GHz emission test.

During the radiated emission test, the spectrum analyzer was set with the following configurations:

Frequency Band (MHz)	Level	Resolution Bandwidth	Video Bandwidth
30 to 1000	QP	120 kHz	300 kHz
Above 1000	Peak	1 MHz	3 MHz
	Average	Peak+ AV Factor	

- Note: (1) Emission Level= Reading Level+Probe Factor +Cable Loss  
 (2) Factor= Antenna Gain + Cable Loss – Amplifier Gain  
 (3) Measurement uncertainty: ±4.68dB  
 (4) Emission (the row indicated by bold) within the restricted band meets the requirement of FCC part 15 Section 15.205.  
 (5) Horn antenna used for the emission over 1000MHz.

### 2.3 Limit

Table A [0.009MHz~1GHz]

Frequency range MHz	Distance Meters	Field Strengths Limit (15.209)
		$\mu\text{V/m}$
0.009 ~ 0.490	300	2400/F(kHz)
0.490 ~ 1.705	30	24000/F(kHz)
1.705 ~ 30	30	30
30 ~ 88	3	100
88 ~ 216	3	150
216 ~ 960	3	200
Above 960	3	500

- Remark: (1) Emission level  $(\text{dB})\mu\text{V} = 20 \log$  Emission level  $\mu\text{V/m}$   
 (2) The smaller limit shall apply at the cross point between two frequency bands.  
 (3) As shown in 15.35(b), for frequencies above 1000MHz, the field strength limits are based on average detector, however, the peak field strength of any emission shall not exceed the maximum permitted average limits, specified above by more than 20dB under any condition of modulation.  
 (4) The frequency range scanned is from the lowest radio frequency signal generated in the device which is greater than 9 kHz to the tenth harmonic of the highest fundamental frequency or 40 GHz, whichever is lower.

Table B

Fundamental Frequency (MHz)	Field Strength of Fundamental		Field Strength of Spurious Emissions	
	$\mu\text{V/m}$	$\text{dB}\mu\text{V/m}$	$\mu\text{V/m}$	$\text{dB}\mu\text{V/m}$
40.66-40.70	1000	60.00	100	40.00
70-130	500	54.00	50	34.00
130-174	500-1500**	54.00-63.52	50-150**	34.00-43.52
174-260	1500	63.52	150	43.52
260-470	1500-5000**	63.52-74.00	150-500**	43.52-54.00
Above 470	5000	74.00	500	54.00

\*\* ) Linear interpolations

Note: Spurious emissions shall be attenuated to the average(or, alternatively, CISPR quasi-peak) limits shown in 15.209, whichever limit permits a higher field strength.

## 2.4 Measurement Results

Pass

Please refer to the following pages.



Dongguan NTC Co., Ltd.  
 Tel:+86-769-22022444 Fax:+86-769-22022799  
 Web: [Http://www.ntc-c.com](http://www.ntc-c.com)

**Radiated Emission Measurement**

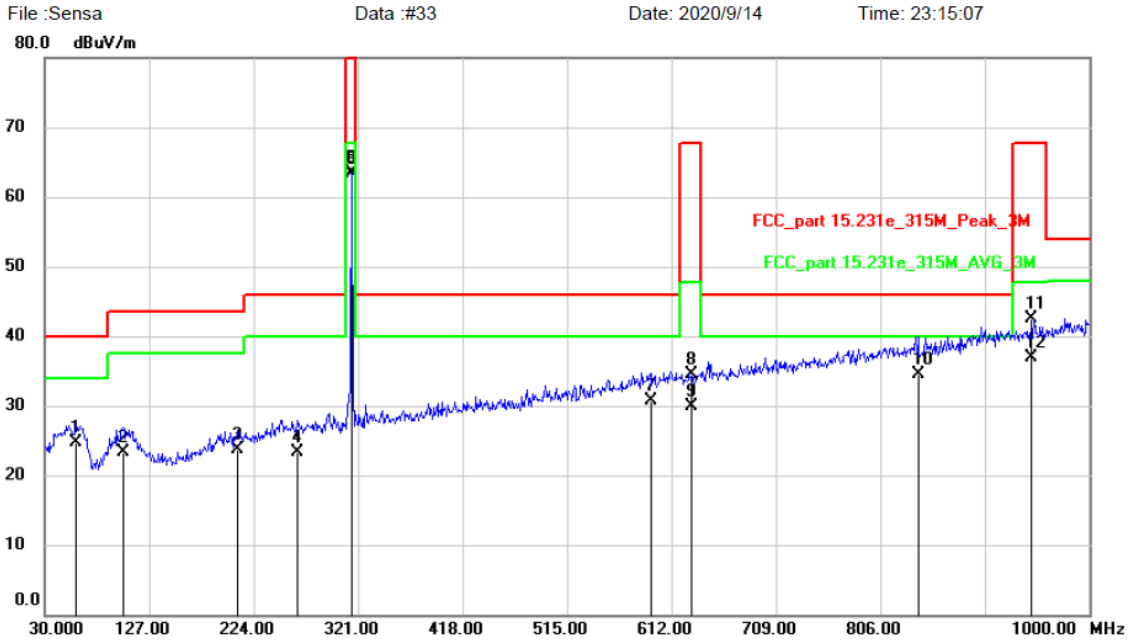

Site: 3m Chamber Polarization: *Horizontal* Temperature: 26  
 Limit: FCC\_part 15.231e\_315M\_Peak\_3M Power: DC 3V Humidity: 47 %  
 EUT: Crib Sensor Remote Distance: 3m  
 M/N: SENSA  
 Mode: TX Mode  
 Note:

No.	Mk.	Freq. MHz	Reading Level dBuV	Correct Factor dB/m	Measure- ment dBuV/m	Limit dBuV/m	Over dB	Antenna Height cm	Table Degree degree	Detector	Comment
1		59.1000	10.56	14.09	24.65	40.00	-15.35			QP	
2		102.7500	9.37	13.86	23.23	43.50	-20.27			QP	
3		209.4500	10.40	13.27	23.67	43.50	-19.83			QP	
4		264.7400	8.54	14.82	23.36	46.00	-22.64			QP	
5		315.0000	47.76	15.81	63.57	87.67	-24.10			peak	
6	*	315.0000	47.43	15.81	63.24	67.67	-4.43			AVG	
7		592.6000	9.48	21.19	30.67	46.00	-15.33			QP	
8		630.0000	12.82	21.69	34.51	67.67	-33.16			peak	
9		630.0000	8.22	21.69	29.91	47.67	-17.76			AVG	
10		840.9200	9.47	25.11	34.58	46.00	-11.42			QP	
11		945.0000	15.35	27.24	42.59	67.67	-25.08			peak	
12		945.0000	9.58	27.24	36.82	47.67	-10.85			AVG	

Note: Below 30MHz, the emissions are lower than 20dB below the allowable limit.



Dongguan NTC Co., Ltd.  
 Tel:+86-769-22022444 Fax:+86-769-22022799  
 Web: [Http://www.ntc-c.com](http://www.ntc-c.com)

**Radiated Emission Measurement**

File :Sensa Data :#34 Date: 2020/9/14 Time: 23:29:58

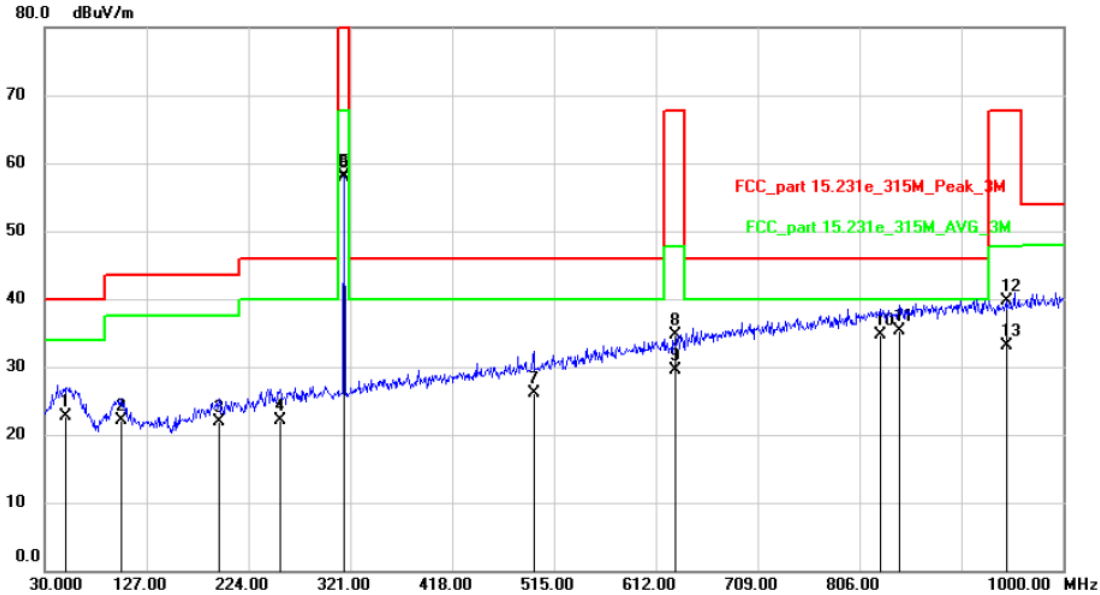

Site: 3m Chamber Polarization: **Vertical** Temperature: 26  
 Limit: FCC\_part 15.231e\_315M\_Peak\_3M Power: DC 3V Humidity: 47 %  
 EUT: Crib Sensor Remote Distance: 3m  
 M/N: SENSA  
 Mode: TX Mode  
 Note:

No.	Mk.	Freq.	Reading Level	Correct Factor	Measurement	Limit	Over	Antenna Height	Table Degree	
		MHz	dBuV	dB/m	dBuV/m	dBuV/m	dB	cm	degree	Comment
1		50.3700	8.27	14.40	22.67	40.00	-17.33	QP		
2		102.7500	9.68	12.47	22.15	43.50	-21.35	QP		
3		195.8700	9.97	12.00	21.97	43.50	-21.53	QP		
4		254.0700	8.46	13.62	22.08	46.00	-23.92	QP		
5		315.0000	43.31	14.81	58.12	87.67	-29.55	peak		
6	*	315.0000	43.15	14.81	57.96	67.67	-9.71	AVG		
7		495.6000	7.73	18.39	26.12	46.00	-19.88	QP		
8		630.0000	13.72	20.99	34.71	67.67	-32.96	peak		
9		630.0000	8.59	20.99	29.58	47.67	-18.09	AVG		
10		825.4000	9.97	24.82	34.79	46.00	-11.21	QP		
11		843.8300	10.09	25.16	35.25	46.00	-10.75	QP		
12		945.0000	13.69	26.03	39.72	67.67	-27.95	peak		
13		945.0000	7.12	26.03	33.15	47.67	-14.52	AVG		

Note: Below 30MHz, the emissions are lower than 20dB below the allowable limit.



Dongguan NTC Co., Ltd.  
 Tel:+86-769-22022444 Fax:+86-769-22022799  
 Web: [Http://www.ntc-c.com](http://www.ntc-c.com)

**Radiated Emission Measurement**

File :Sensa Data :#31 Date: 2020/9/14 Time: 21:22:30

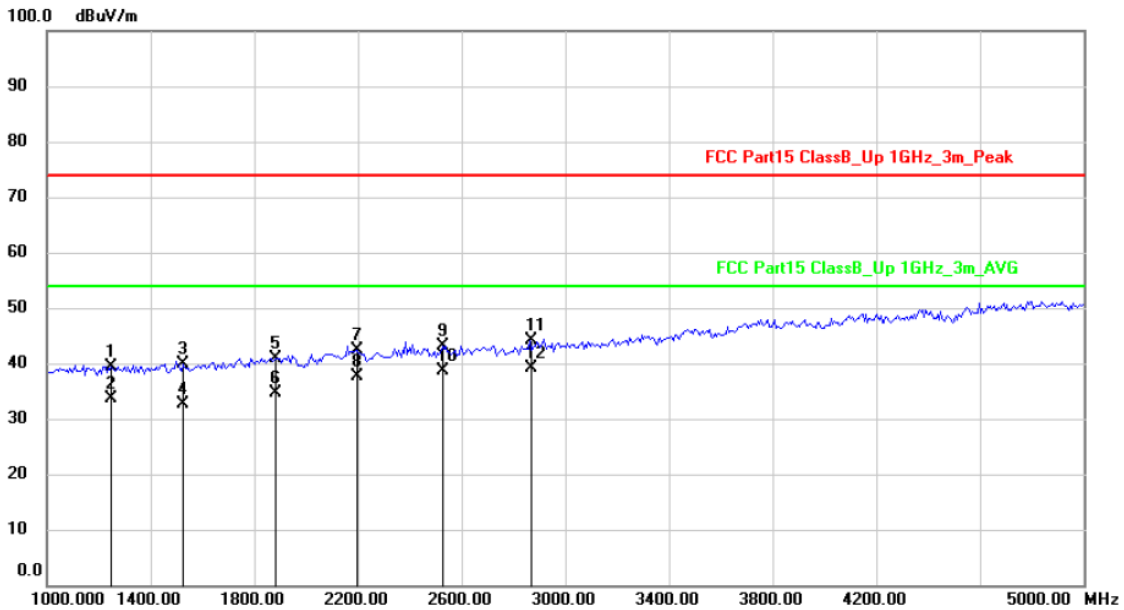

Site: 3m Chamber Polarization: *Horizontal* Temperature: 26  
 Limit: FCC Part15 ClassB\_Up 1GHz\_3m\_Peak Power: DC 3V Humidity: 47 %  
 EUT: Crib Sensor Remote Distance: 3m  
 M/N: SENSA  
 Mode: TX Mode  
 Note:

No. Mk.	Freq.	Reading Level	Correct Factor	Measurement	Limit	Over	Antenna Height	Table Degree	
	MHz	dBuV	dB/m	dBuV/m	dBuV/m	dB	cm	degree	Comment
1	1250.000	47.38	-7.88	39.50	74.00	-34.50			peak
2	1250.000	41.45	-7.88	33.57	54.00	-20.43			AVG
3	1525.641	46.29	-6.45	39.84	74.00	-34.16			peak
4	1525.641	39.14	-6.45	32.69	54.00	-21.31			AVG
5	1884.615	43.22	-2.38	40.84	74.00	-33.16			peak
6	1884.615	36.97	-2.38	34.59	54.00	-19.41			AVG
7	2192.308	42.90	-0.41	42.49	74.00	-31.51			peak
8	2192.308	37.92	-0.41	37.51	54.00	-16.49			AVG
9	2525.641	42.60	0.49	43.09	74.00	-30.91			peak
10	2525.641	38.03	0.49	38.52	54.00	-15.48			AVG
11	2865.385	42.53	1.52	44.05	74.00	-29.95			peak
12 *	2865.385	37.69	1.52	39.21	54.00	-14.79			AVG



Dongguan NTC Co., Ltd.  
 Tel:+86-769-22022444 Fax:+86-769-22022799  
 Web: [Http://www.ntc-c.com](http://www.ntc-c.com)

**Radiated Emission Measurement**

File :Sensa Data :#32 Date: 2020/9/14 Time: 21:31:13

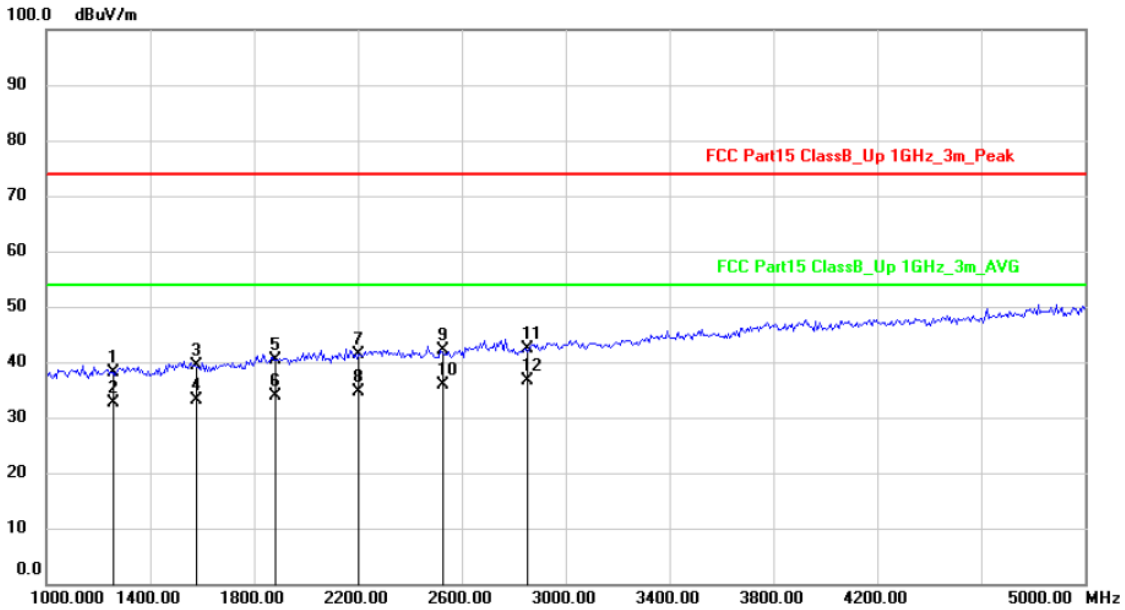

Site: 3m Chamber Polarization: **Vertical** Temperature: 26  
 Limit: FCC Part15 ClassB\_Up 1GHz\_3m\_Peak Power: DC 3V Humidity: 47 %  
 EUT: Crib Sensor Remote Distance: 3m  
 M/N: SENSA  
 Mode: TX Mode  
 Note:

No.	Mk.	Freq.	Reading Level	Correct Factor	Measurement	Limit	Over	Antenna Height	Table Degree	
		MHz	dBuV	dB/m	dBuV/m	dBuV/m	dB	cm	degree	Comment
1		1256.410	46.10	-7.85	38.25	74.00	-35.75			peak
2		1256.410	40.36	-7.85	32.51	54.00	-21.49			AVG
3		1570.513	45.69	-6.21	39.48	74.00	-34.52			peak
4		1570.513	39.30	-6.21	33.09	54.00	-20.91			AVG
5		1884.615	42.82	-2.38	40.44	74.00	-33.56			peak
6		1884.615	36.17	-2.38	33.79	54.00	-20.21			AVG
7		2205.128	41.79	-0.38	41.41	74.00	-32.59			peak
8		2205.128	34.96	-0.38	34.58	54.00	-19.42			AVG
9		2519.231	41.54	0.47	42.01	74.00	-31.99			peak
10		2519.231	35.47	0.47	35.94	54.00	-18.06			AVG
11		2846.154	40.81	1.48	42.29	74.00	-31.71			peak
12	*	2846.154	35.16	1.48	36.64	54.00	-17.36			AVG

### 3. Occupied Bandwidth

#### 3.1 Measurement Procedure

The antenna port of the EUT was connected to the input of a spectrum analyzer. Analyzer RBW was chosen so that the display was a result of the hopping channel modulation. For each RF output channel investigated, the spectrum analyzer center frequency was set to the channel carrier. Use the spectrum 20dB down delta function to measure the bandwidth.

#### 3.2 Test SET-UP (Block Diagram of Configuration)

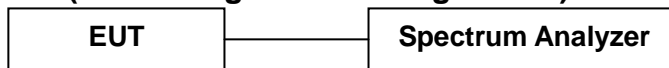

#### 3.3 Limit

Please refer section 15.231

According to 15.231(C), the bandwidth of the emission shall be no wider than 0.25% of the center frequency for devices operating above 70MHz and below 900MHz.

$$\text{Limit} = 315 * 0.25\% = 787.5\text{KHz}$$

#### 3.4 Measurement Results

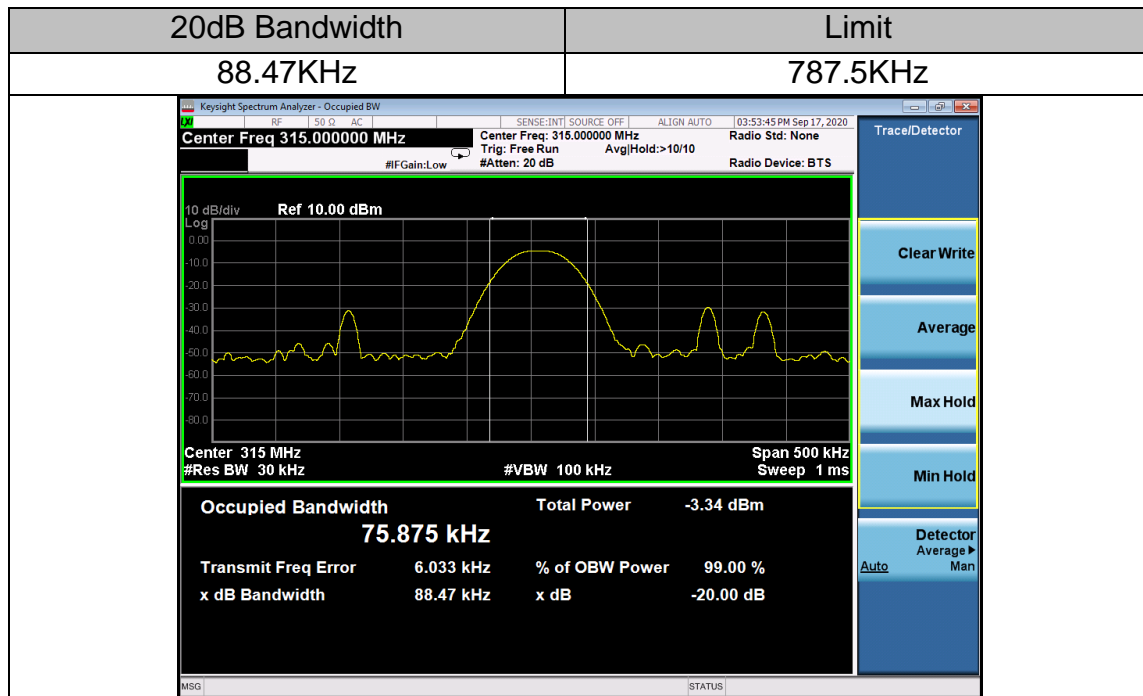



## 4 Transmission Time

### 4.1 Measurement Procedure

Same as section 3.1.

### 4.2 Test SET-UP (Block Diagram of Configuration)

Same as section 3.2.

### 4.3 Limit

According to 15.231(e), Intentional radiators may operate at a periodic rate exceeding that specified in paragraph (a) of this section and may be employed for any type of operation, including operation prohibited in paragraph (a) of this section. Devices operated under the provisions of this paragraph shall be provided with a means for automatically limiting operation so that the duration of each transmission shall not be greater than one second and the silent period between transmissions shall be at least 30 times the duration of the transmission but in no case less than 10 seconds.

### 4.4 Measurement Results

Transmission Time	Limit
0.56 s	1 s
Silent Period Between Transmissions	Limit
180.6s	>10s

Transmission Time=140ms+138ms+140ms+142ms=0.56s

## Transmission Time

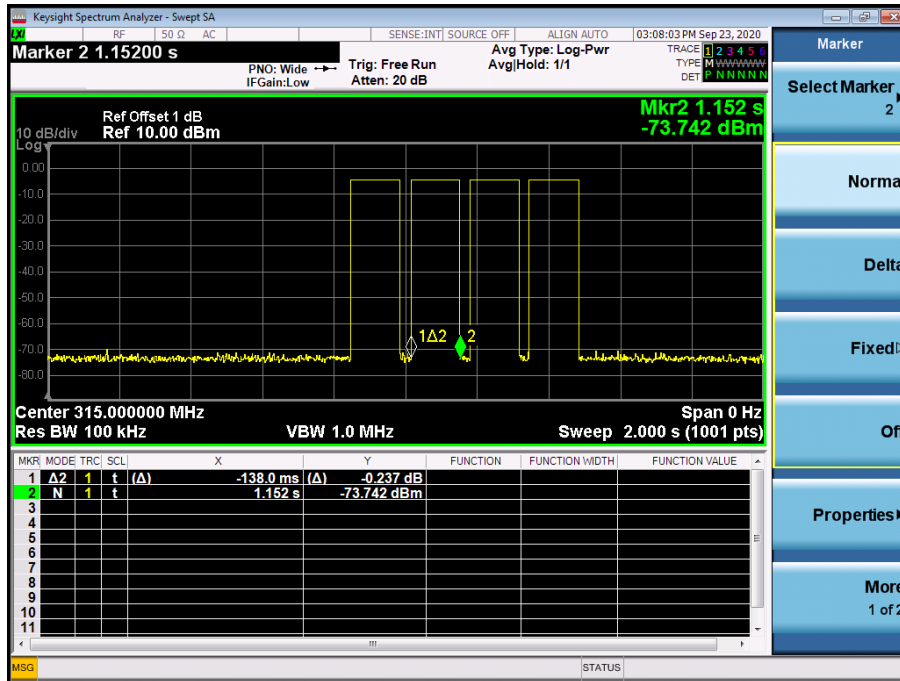
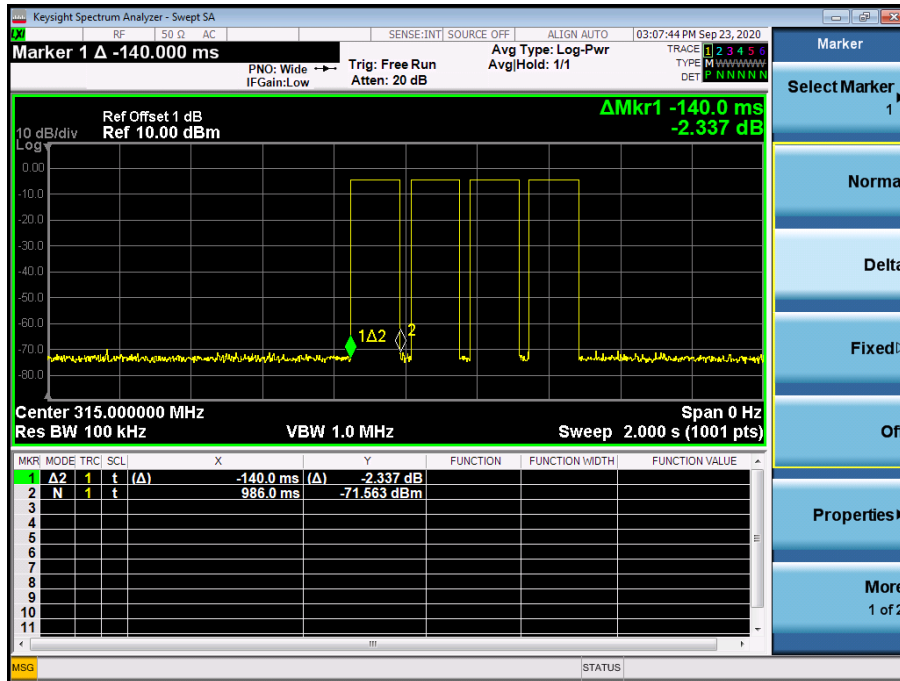

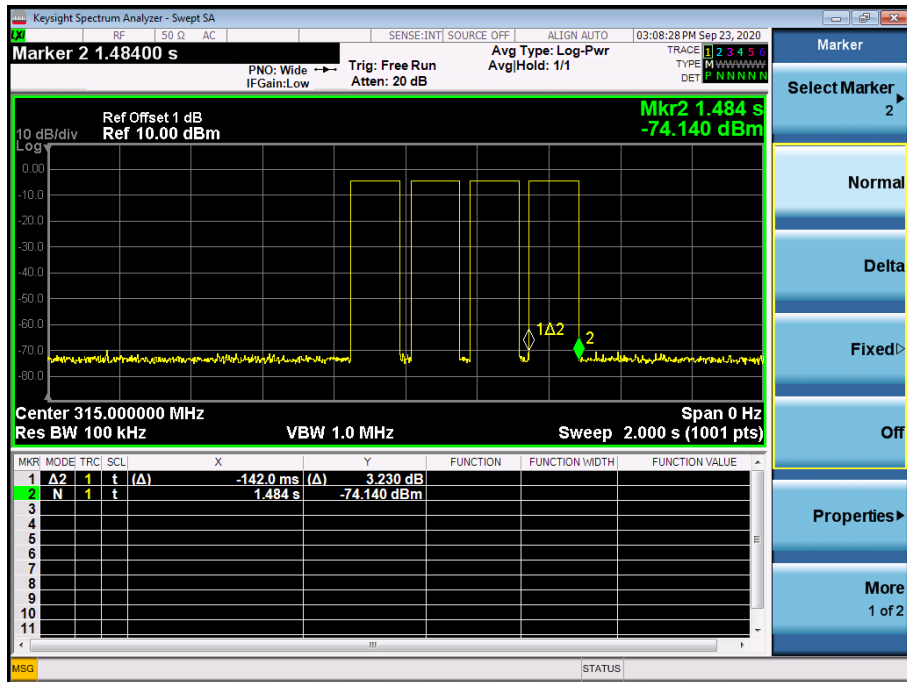
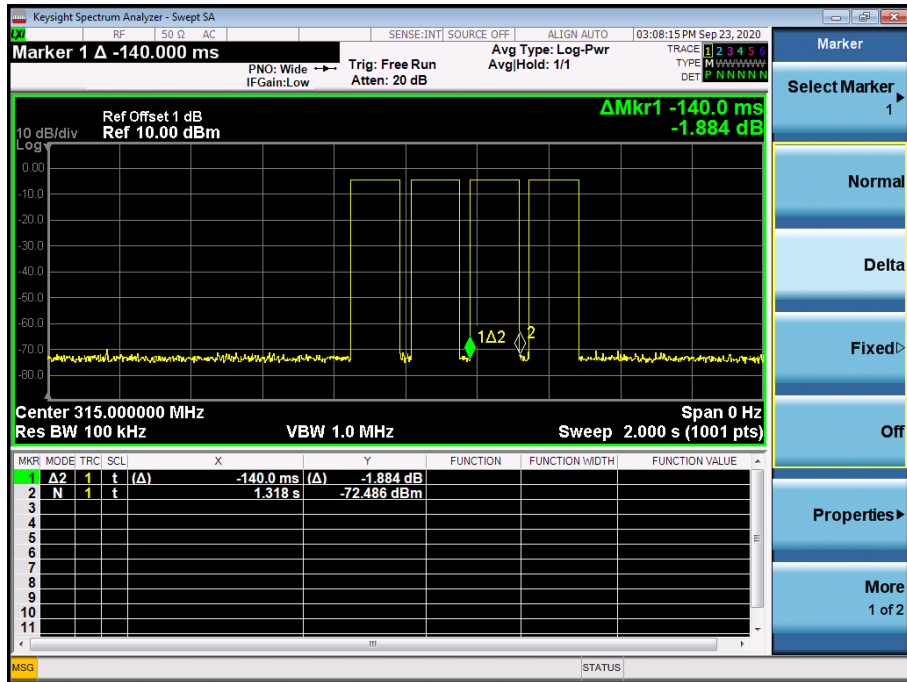

## Silent Period between Transmissions

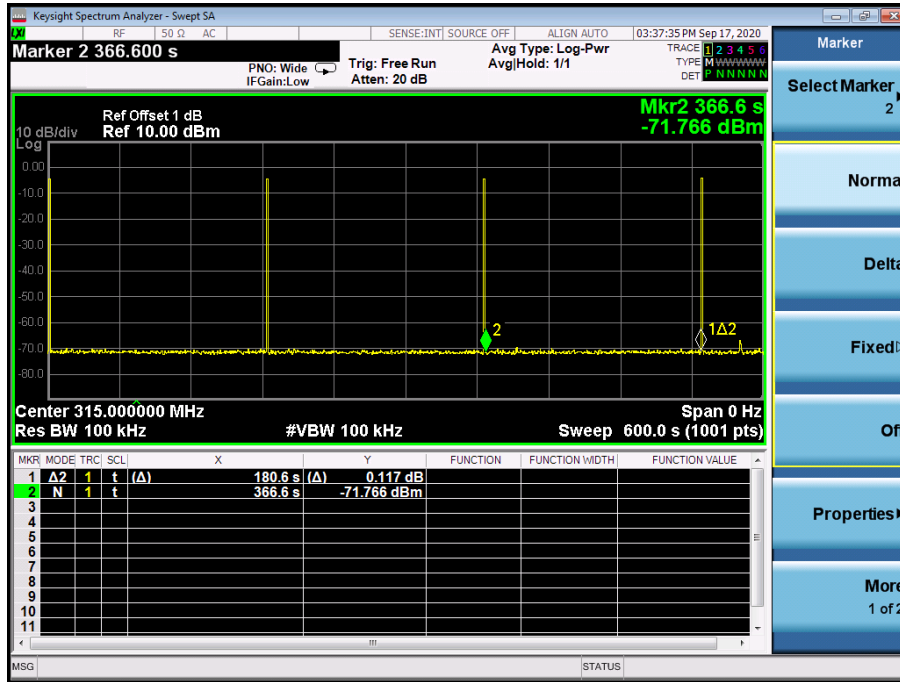

---

## 5. Antenna Application

### 5.1 Antenna requirement

According to of FCC part 15C section 15.203 and 15.240:

An intentional radiator shall be designed to ensure that no antenna other than that furnished by the responsible party shall be used with the device. The use of a permanently attached antenna or of an antenna that uses a unique coupling to the intentional radiator, the manufacturer may design the unit so that a broken antenna can be replaced by the user, but the use of a standard antenna jack or electrical connector is prohibited.

### 5.2 Measurement Results

The antenna is PCB antenna and no consideration of replacement, and the best case gain of the antenna is 0 dBi. Therefore, the antenna is consider meet the requirement.

## 6. Test Equipment List

Item	Equipment	Manufacturer	Model No.	Serial No.	Last Cal.	Cal. Interval
1.	Test Receiver	Rohde & Schwarz	ESC17	100837	Mar. 13, 2020	1 Year
2.	Antenna	Schwarzbeck	VULB9162	9162-010	Mar. 23, 2020	1 Year
3.	Spectrum Analyzer	Rohde & Schwarz	FSU26	200409/026	Mar. 13, 2020	1 Year
4.	Spectrum Analyzer	Keysight	N9020A	MY54200831	Mar. 13, 2020	1 Year
5.	Spectrum Analyzer	Rohde & Schwarz	FSV40	101094	Mar. 13, 2020	1 Year
6.	Horn Antenna	Schwarzbeck	BBHA9170	9170-172	Mar. 22, 2019	2 Year
7.	Power Crib Sensor Remote	DARE	RPR3006W	15100041SNO 64	Mar. 13, 2020	1 Year
8.	Power Crib Sensor Remote	DARE	RPR3006W	15100041SNO 88	Mar. 13, 2020	1 Year
9.	Communication Tester	Rohde & Schwarz	CMW500	149004	Mar. 13, 2020	1 Year
10.	Horn Antenna	COM-Power	AH-118	071078	Mar. 23, 2020	1 Year
11.	Pre-Amplifier	HP	HP 8449B	3008A00964	Mar. 13, 2020	1 Year
12.	Pre-Amplifier	HP	HP 8447D	1145A00203	Mar. 13, 2020	1 Year
13.	Loop Antenna	Schwarzbeck	FMZB 1513	1513-272	Mar. 23, 2020	1 Year
14.	Test Receiver	Rohde & Schwarz	ESCI	101152	Mar. 14, 2020	1 Year
15.	L.I.S.N	Rohde & Schwarz	ENV 216	101317	Mar. 13, 2020	1 Year
16.	L.I.S.N	Rohde & Schwarz	ESH2-Z5	893606/014	Mar. 13, 2020	1 Year
17.	RF Switching Unit	Compliance Direction Systems Inc.	RSU-M2	38311	Mar.13, 2020	1 Year
18.	Temperature & Humidity Chamber	REMAFEE	SYHR225L	N/A	Mar. 13, 2020	1 Year
19.	DC Source	Maynuo	MY8811	N/A	Mar. 13, 2020	1 Year
20.	Temporary antenna connector	TESCOM	SS402	N/A	N/A	N/A
21.	Chamber	SAEMC	9*7*7m	N/A	Jun. 20, 2019	2 Year
22.	Test Software	EZ	EZ_EMCC	N/A	N/A	N/A

Note: The temporary antenna connector is soldered on the PCB board in order to perform conducted tests and this temporary antenna connector is listed in the equipment list.

---End---