



**FCC 47 CFR PART 15 SUBPART C AND ANSI C63.4:2003
TEST REPORT**

For

Wireless IP CAM

Model : F5115

Data Applies To : F5105

Trade Name : ZAVIO

Issued for

ZAVIO Inc.

**B3, 1F, NO. 1, Lising 1st Rd., Science-Based Industrial Park,
Hsinchu, Taiwan**

Issued by

**Compliance Certification Services Inc.
Hsinchu Lab.**

**NO. 989-1 Wen Shan Rd., Shang Shan Village,
Qionglin Shiang Hsinchu County 30741, Taiwan, R.O.C**

TEL: +886-3-5921698

FAX: +886-3-5921108

<http://www.ccsrf.com>

E-Mail : service@ccsrf.com



Note: *This report shall not be reproduced except in full, without the written approval of Compliance Certification Services Inc. This document may be altered or revised by Compliance Certification Services Inc. personnel only, and shall be noted in the revision section of the document. The client should not use it to claim product endorsement by TAF or any government agencies. The test results in the report only apply to the tested sample.*



Revision History

Rev.	Issue Date	Revisions	Effect Page	Revised By
00	06/30/2010	Initial Issue	All Page 66	Winnie Chen



TABLE OF CONTENTS

TITLE	PAGE NO.
1. TEST REPORT CERTIFICATION	4
2. EUT DESCRIPTION	5
2.1 DESCRIPTION OF EUT & POWER	5
3. DESCRIPTION OF TEST MODES	6
4. TEST METHODOLOGY	6
5. FACILITIES AND ACCREDITATION	6
5.1 FACILITIES	6
5.2 ACCREDITATIONS.....	7
5.3 MEASUREMENT UNCERTAINTY	7
6. SETUP OF EQUIPMENT UNDER TEST.....	8
7. FCC PART 15.247 REQUIREMENTS	10
7.1 6dB BANDWIDTH	10-15
7.2 MAXIMUM PEAK OUTPUT POWER	16-21
7.3 AVERAGE POWER	22-23
7.4 POWER SPECTRAL DENSITY	24-29
7.5 CONDUCTED SPURIOUS EMISSION	30-34
7.6 RADIATED EMISSION.....	35-53
7.7 CONDUCTED EMISSION.....	54-58
APPENDIX I MAXIMUM PERMISSIBLE EXPOSURE	59-60
APPENDIX II SETUP PHOTOS	61-66



1. TEST REPORT CERTIFICATION

Applicant : ZAVIO Inc.
Address : B3, 1F, NO. 1, Lising 1st Rd., Science-Based Industrial Park,
Hsinchu, Taiwan
Equipment Under Test : Wireless IP CAM
Model : F5115
Data Applies To : F5105
Trade Name : ZAVIO
Tested Date : May 25 ~ June 30, 2010

APPLICABLE STANDARD	
Standard	Test Result
FCC Part 15 Subpart C AND ANSI C63.4:2003	PASS

WE HEREBY CERTIFY THAT: The above equipment has been tested by Compliance Certification Services Inc., and found compliance with the requirements set forth in the technical standards mentioned above. The results of testing in this report apply only to the product/system, which was tested. Other similar equipment will not necessarily produce the same results due to production tolerance and measurement uncertainties.

Approved by:

Reviewed by:

Gungdam Lin
Team Leader

Sb Lu
Sr. Engineer



2. EUT DESCRIPTION

2.1 DESCRIPTION OF EUT & POWER

Product Name	Wireless IP CAM
Model Number	F5115
Data Applies To	F5105
Received Date	May 25, 2010
Frequency Range	IEEE 802.11b/g : 2412MHz ~ 2462MHz
Transmit Power	IEEE 802.11b : 21.75dBm (0.1496W) IEEE 802.11g : 19.68dBm (0.0929W)
Channel Spacing	IEEE 802.11b/g : 5MHz
Channel Number	IEEE 802.11b/g : 11 Channels
Transmit Data Rate	IEEE 802.11b : 11, 5.5, 2, 1 Mbps IEEE 802.11g : 54, 48, 36, 24, 18, 12, 9, 6 Mbps
Type of Modulation	IEEE 802.11b : DSSS (CCK, DQPSK, DBPSK) IEEE 802.11g : OFDM (64QAM, 16QAM, QPSK, BPSK)
Antenna Type	Dipole Antenna , Antenna Gain 2dBi Connector : SMA Male RP
DC Power Cord Type	Unshielded cable 1.8 m (no detachable)
Power Source	12VDC, 1.25A (From Power Adapter)
I/O Port	RJ-45 port x 1 , Audio In port x 1, Audio Out port x 1 , Power port x 1 , DI+DI-Com No port x 1

Power Adapter :

No.	Manufacturer	Model No.	Power Input	Power Output
1	FAIRWAY	WRG15F-120A	100-240VAC, 1.0A max, 50/60Hz	12V, 1.25A

The difference of the series model

Mode Number	Difference
F5115	The CCD camera has a LED light around.
F5105	The CCD camera has no LED light around.

Remark :

1. The sample selected for test was engineering sample that approximated to production product and was provided by manufacturer.
2. For more details, please refer to the User's manual of the EUT.
3. This submittal(s) (test report) is intended for FCC ID: WOR-5115F filing to comply with Section 15.207, 15.209 and 15.247 of the FCC Part 15, Subpart C Rules.



3. DESCRIPTION OF TEST MODES

The EUT had been tested under operating condition.

There are three channels have been tested as following :

Channel	Frequency (MHz)
Low	2412
Middle	2437
High	2462

IEEE 802.11b mode : 1Mbps data rate (worst case) were chosen for full testing.

IEEE 802.11g mode : 6Mbps data rate (worst case) were chosen for full testing.

4. TEST METHODOLOGY

The tests documented in this report were performed in accordance with ANSI C63.4 : 2003 and FCC CFR 47, 15.207, 15.209 and 15.247.

5. FACILITIES AND ACCREDITATION

5.1 FACILITIES

All measurement facilities used to collect the measurement data are located at

NO. 989-1 Wen Shan Rd., Shang Shan Village,
Qionglin Shiang Hsinchu County 30741, Taiwan, R.O.C

The sites are constructed in conformance with the requirements of ANSI C63.4 :2003 and CISPR 22. All receiving equipment conforms to CISPR 16-1-1, CISPR 16-1-2, CISPR 16-1-3, CISPR 16-1-4, CISPR 16-1-5.



5.2 ACCREDITATIONS

Our laboratories are accredited and approved by the following approval agencies according to ISO/IEC 17025.

Taiwan TAF

The measuring facility of laboratories has been authorized or registered by the following approval agencies.

Taiwan BSMI
USA FCC MRA

Copies of granted accreditation certificates are available for downloading from our web site, <http://www.ccsrf.com>

5.3 MEASUREMENT UNCERTAINTY

The following table is for the measurement uncertainty, which is calculated as per the document CISPR 16-4-2.

PARAMETER	UNCERTAINTY
Open Area Test Site (OATS No.3) / Radiated Emission, 30 to 200 MHz	+/- 3.9267
Open Area Test Site (OATS No.3) / Radiated Emission, 200 to 1000 MHz	+/- 3.6899
Semi Anechoic Chamber (966 Chamber) / Radiated Emission, 30 to 200 MHz	+/- 3.6878
Semi Anechoic Chamber (966 Chamber) / Radiated Emission, 200 to 1000 MHz	+/- 3.0885
Semi Anechoic Chamber (966 Chamber) / Radiated Emission, 1 to 26.5GHz	+/- 3.2000
Conducted Emission, 9kHz to 30MHz	+/- 1.7468

This uncertainty represents an expanded uncertainty expressed at approximately the 95% confidence level using a coverage factor of k=2.

Consistent with industry standard (e.g. CISPR 22: 2006, clause 11, Measurement Uncertainty) determining compliance with the limits shall be base on the results of the compliance measurement. Consequently the measure emissions being less than the maximum allowed emission result in this be a compliant test or passing test.

The acceptable measurement uncertainty value without requiring revision of the compliance statement is base on conducted and radiated emissions being less than U_{CISPR} which is 3.6dB and 5.2dB respectively. CCS values (called U_{Lab} in CISPR 16-4-2) is less than U_{CISPR} as shown in the table above. Therefore, MU need not be considered for compliance.



6. SETUP OF EQUIPMENT UNDER TEST

SUPPORT EQUIPMENT

No.	Product	Manufacturer	Model No.	Serial No.	FCC ID
1	Notebook PC	DELL	Latitude D610	CN-0C4708-48643-62 5-5565	E2K24BNHM
2	Notebook PC	Lenovo ideaPad	S10e_4068-R Z1	L3CEV2D	HFS-FL
3	Headset/Microphone	ERGOTECH	ET-E203	4719405008042	-----
4	Wireless Gigabit Router	D-Link	DI-724GU	-----	-----

No.	Signal Cable Description
1	Unshielded RJ-45 cable, 12m x1

SETUP DIAGRAM FOR TESTS

EUT & peripherals setup diagram is shown in appendix setup photos.

EUT OPERATING CONDITION

RF Mode

1. Set up whole system for test as shown on diagram.
2. pc a fixed ip, into the Network Neighborhood to confirm EUT obtained ip
3. Run Putty software→IP address 192.168.1.121
4. Account:debuggerofzavio
5. Passsword:admin
6. su<enter>
 - iwpriv ra0 set ATE=STASTOP
 - iwpriv ra0 set ATEDA=00:11:22:33:44:55
 - iwpriv ra0 set ATESA=00:aa:bb:cc:dd:ee
 - iwpriv ra0 set ATEBSSID=00:11:22:33:44:55
 - iwpriv ra0 set ATETXRATE=XX (range 0~11)
 - iwpriv ra0 set ATECHANNEL=XX (range 1~14)
 - iwpriv ra0 set ATETXLEN=1024
 - iwpriv ra0 set ATETXPOW=XX (range 0~31)
 - iwpriv ra0 set ATETXCNT=XX (range 1~XX...X)
 - iwpriv ra0 set ATE=TXFRAME<enter>



TX Mode:

- ⇒ Tx Data Rate:1Mbps (IEEE 802.11b mode)
6Mbps (IEEE 802.11g mode)
- ⇒ Power control mode:
 - Power Set: IEEE 802.11b
 - Channel Low (2412MHz) =28
 - Channel Middle (2437MHz) = 31
 - Channel High (2462MHz) = 31
 - Power Set: IEEE 802.11g
 - Channel Low (2412MHz) =31
 - Channel Middle (2437MHz) =31
 - Channel High (2462MHz) = 31

7. All of the function are under run.

8. Start: Receive

Normal Mode

1. Setup whole system for test as shown on diagram
2. Wireless Router to provide IP to the EUT.
3. Notebook PC (1) ping 192.168.1.212 to EUT.
4. Notebook PC (2) ping 192.168.0.151 to EUT.
5. Audio In/Out link Headset/Microphone.
6. All of the function are under run.
7. Start test.



7. FCC PART 15.247 REQUIREMENTS

7.1 6dB BANDWIDTH

LIMITS

§ 15.247(a) (2) For direct sequence systems, the minimum 6dB bandwidth shall be at least 500kHz.

TEST EQUIPMENT

Name of Equipment	Manufacturer	Model	Serial Number	Calibration Due
Spectrum Analyzer	AGILENT	E4446A	MY43360132	06/20/2011
Spectrum Analyzer	AGILENT	E4446A	MY46180323	05/02/2011

Remark: Each piece of equipment is scheduled for calibration once a year.

TEST SETUP

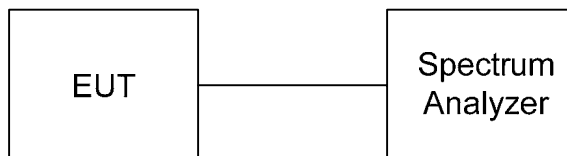

TEST PROCEDURE

The transmitter output was connected to a spectrum analyzer. The bandwidth of the fundamental frequency was measured by spectrum analyzer with 100 KHz RBW and 300 KHz VBW. The 6dB bandwidth is defined as the total spectrum the power of which is higher than peak power minus 6dB.



TEST RESULTS

IEEE 802.11b Mode

Channel	Channel Frequency (MHz)	6dB Bandwidth (MHz)	Minimum Limit (kHz)	Pass / Fail
Low	2412	12.25	500	PASS
Middle	2437	12.00	500	PASS
High	2462	11.25	500	PASS

IEEE 802.11g Mode

Channel	Channel Frequency (MHz)	6dB Bandwidth (MHz)	Minimum Limit (kHz)	Pass / Fail
Low	2412	16.50	500	PASS
Middle	2437	16.50	500	PASS
High	2462	16.33	500	PASS



6dB BANDWIDTH

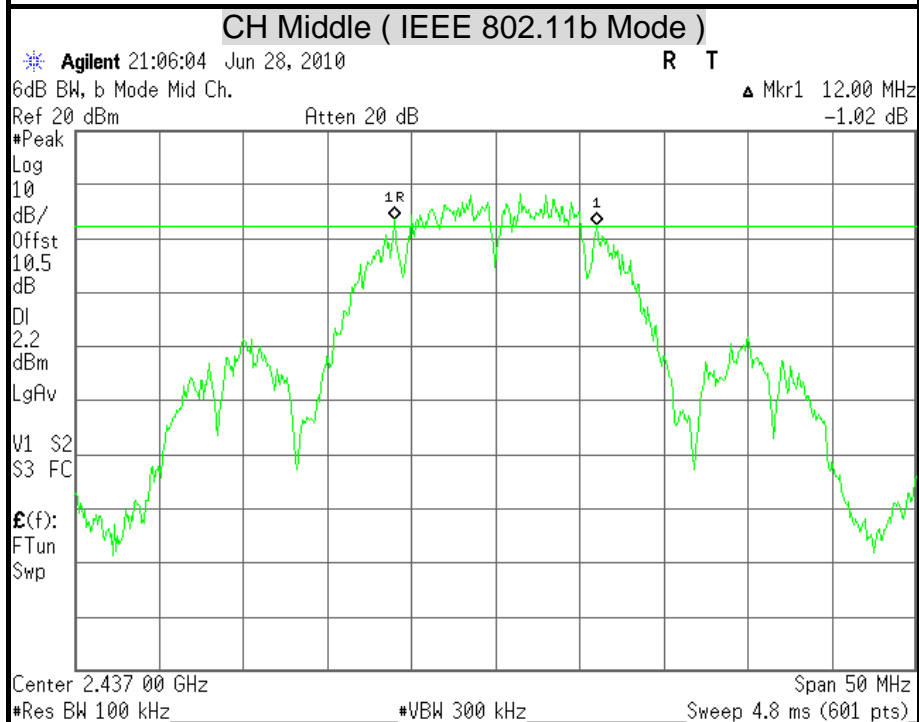
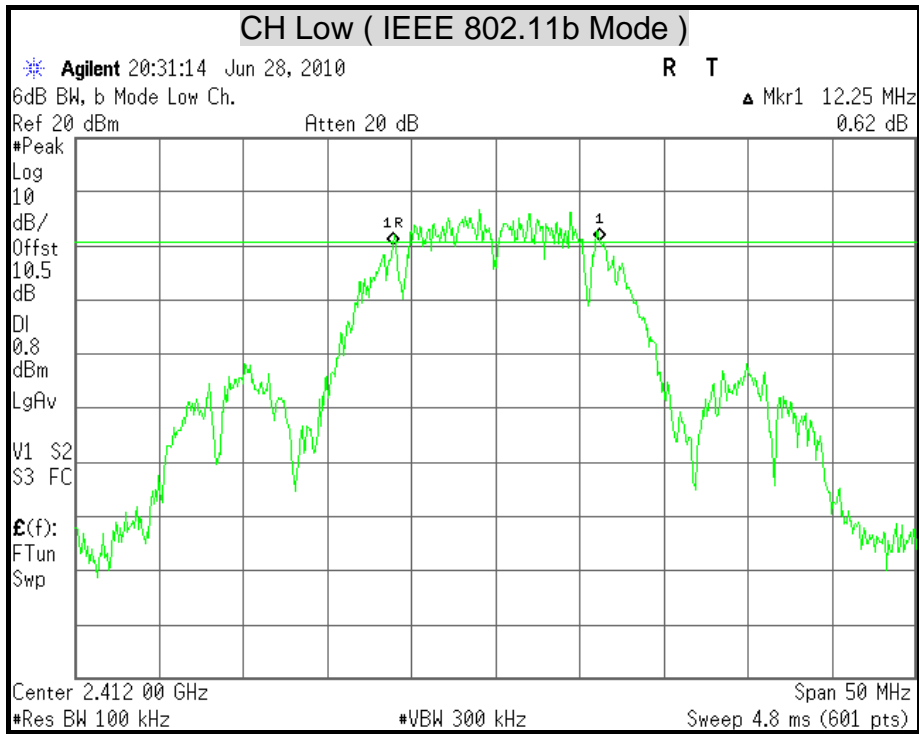

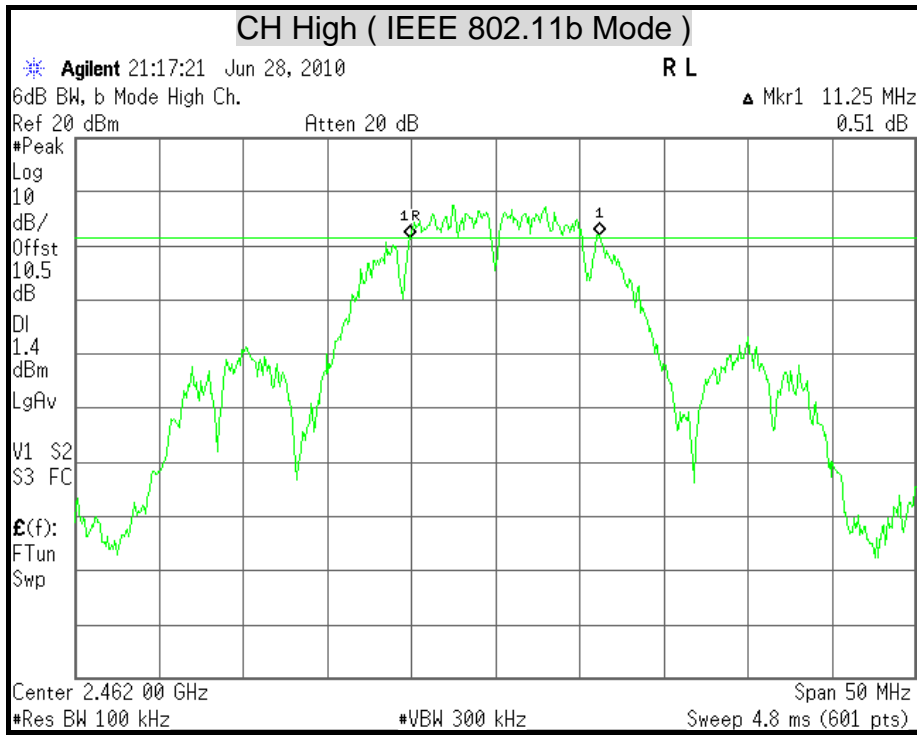

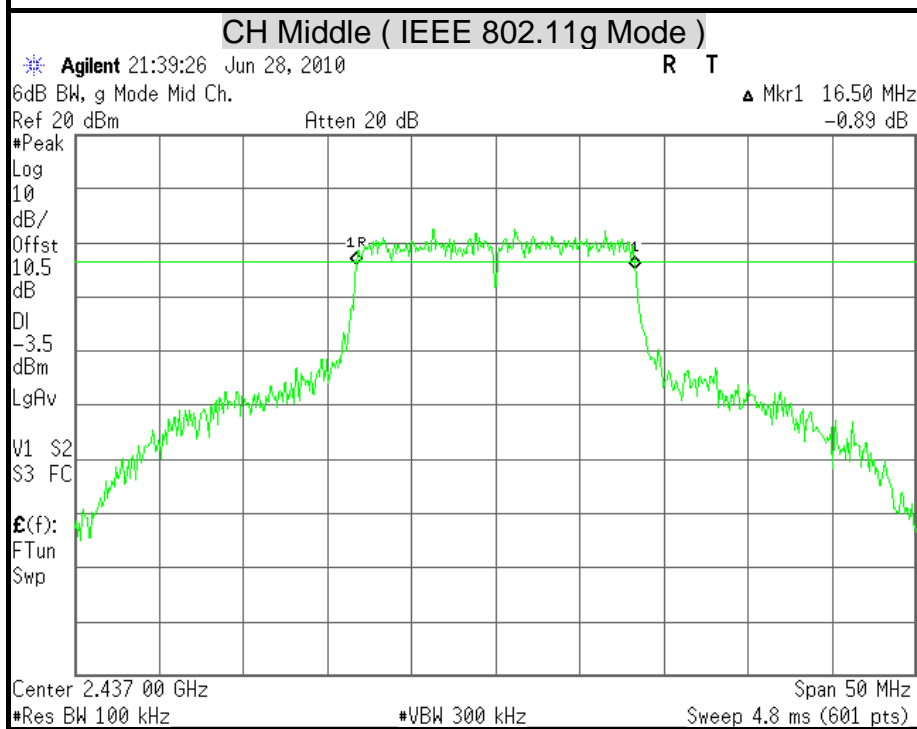
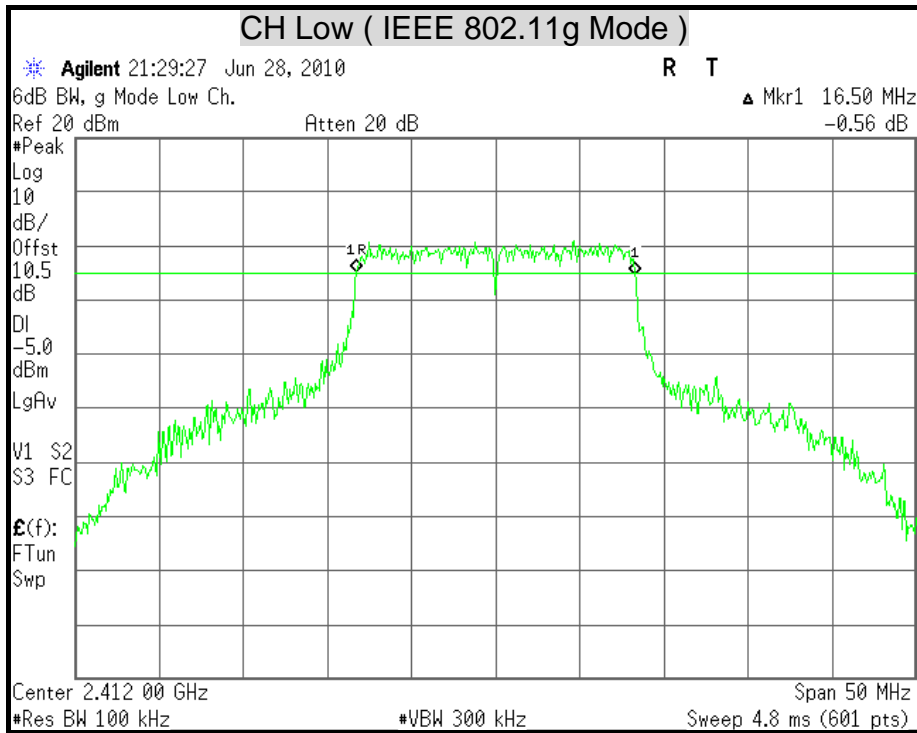

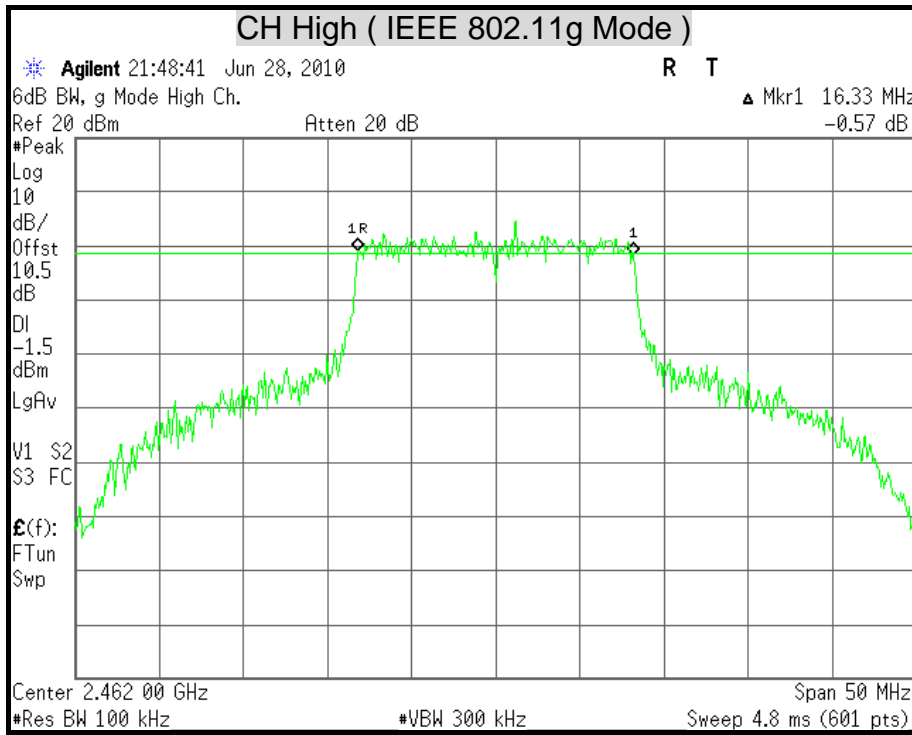



7.2 MAXIMUM PEAK OUTPUT POWER

LIMITS

§ 15.247(b) The maximum peak output power of the intentional radiator shall not exceed the following :

§ 15.247(b) (3) For systems using digital modulation in the 902-928 MHz, 2400-2483.5 MHz, and 5725-5850 MHz bands : 1 watt.

§ 15.247(b) (4) Except as shown in paragraphs (c) of this section, if transmitting antennas of directional gain greater than 6 dBi are used the peak output power from the intentional radiator shall be reduced below the stated values in paragraphs (b)(1) or (b)(2), and (b)(3) of this section, as appropriate, by the amount in dB that the directional gain of the antenna exceeds 6 dBi.

TEST EQUIPMENT

Name of Equipment	Manufacturer	Model	Serial Number	Calibration Due
Spectrum Analyzer	AGILENT	E4446A	MY43360132	06/20/2011
Spectrum Analyzer	AGILENT	E4446A	MY46180323	05/02/2011

Remark: Each piece of equipment is scheduled for calibration once a year.

TEST SETUP



TEST PROCEDURE

1. The spectrum shall be set as follows :
Span : 1.5 times channel integration bandwidth.
RBW : 1MHz
VBW : 3MHz
Detector : Peak
Sweep : Single trace
2. Compute the combined power of all signal responses contained in the trace by covering all the data points.
3. The peak output power is the channel power integrated over 26dB bandwidth.



TEST RESULTS

IEEE 802.11b Mode

Channel	Channel Frequency (MHz)	Peak Power		Peak Power Limit		Pass / Fail
		(dBm)	(W)	(dBm)	(W)	
Low	2412	20.93	0.1239	30	1	PASS
Middle	2437	21.49	0.1409	30	1	PASS
High	2462	21.75	0.1496	30	1	PASS

Remark:

1. At final test to get the worst-case emission at 1Mbps.
2. The cable assembly insertion loss of 10.5dB (including 10 dB pad and 0.5 dB cable) was Entered as an offset in the spectrum analyzer to allow for direct reading of power.

IEEE 802.11g Mode

Channel	Channel Frequency (MHz)	Peak Power		Peak Power Limit		Pass / Fail
		(dBm)	(W)	(dBm)	(W)	
Low	2412	19.09	0.0811	30	1	PASS
Middle	2437	19.36	0.0863	30	1	PASS
High	2462	19.68	0.0929	30	1	PASS

Remark:

1. At final test to get the worst-case emission at 6Mbps.
2. The cable assembly insertion loss of 10.5dB (including 10 dB pad and 0.5 dB cable) was Entered as an offset in the spectrum analyzer to allow for direct reading of power.



MAXIMUM PEAK OUTPUT POWER

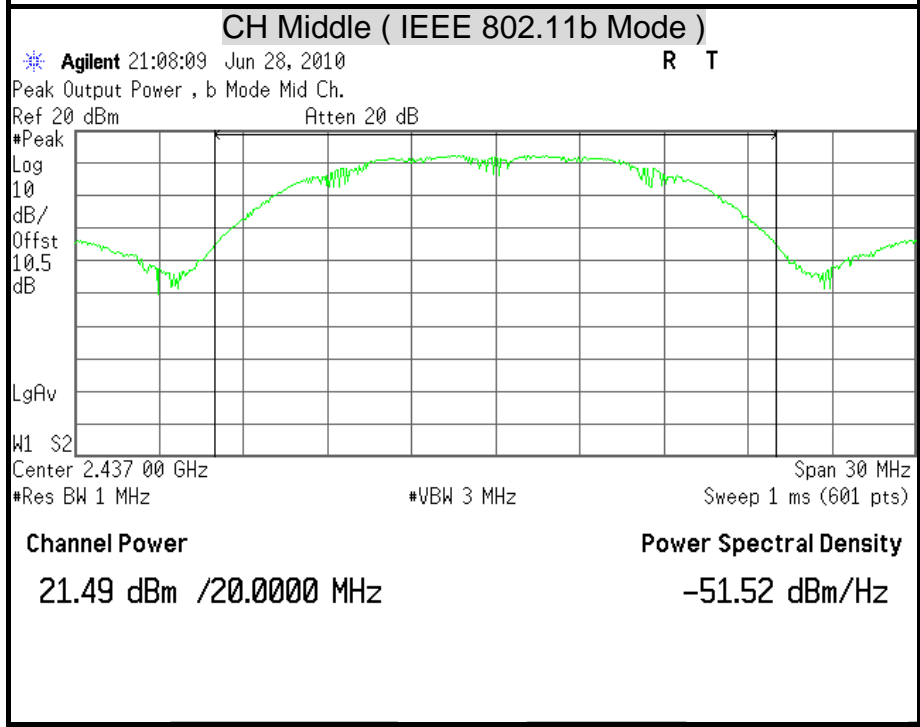
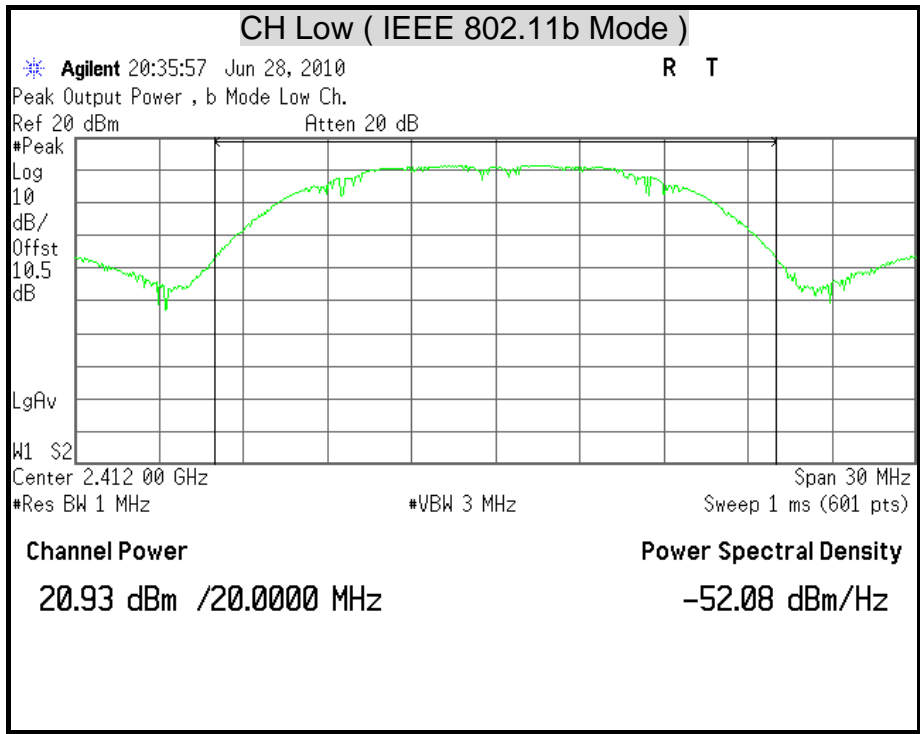

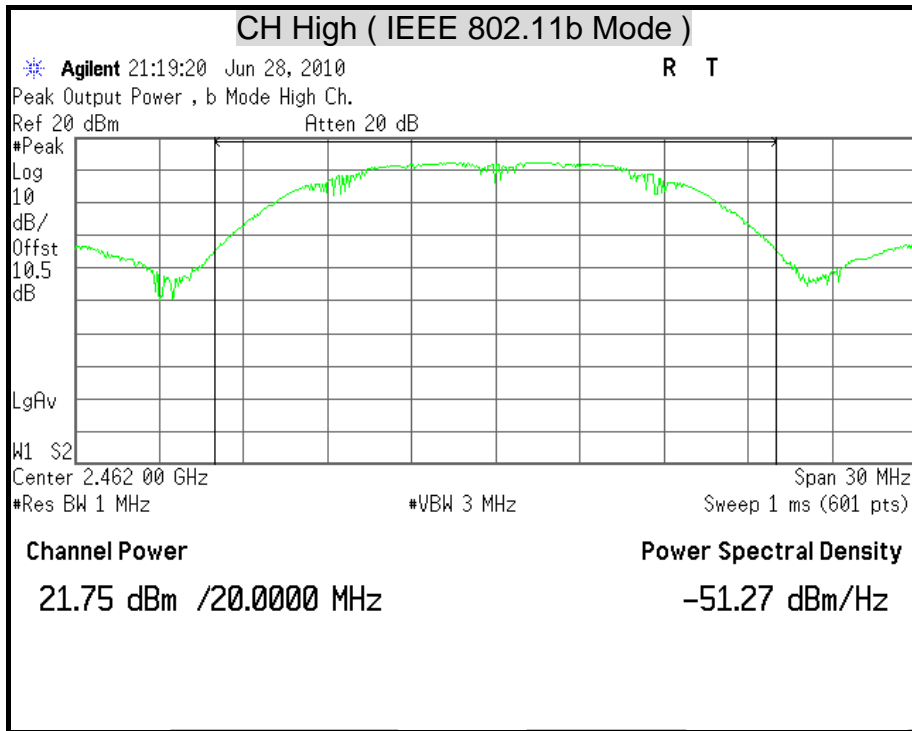

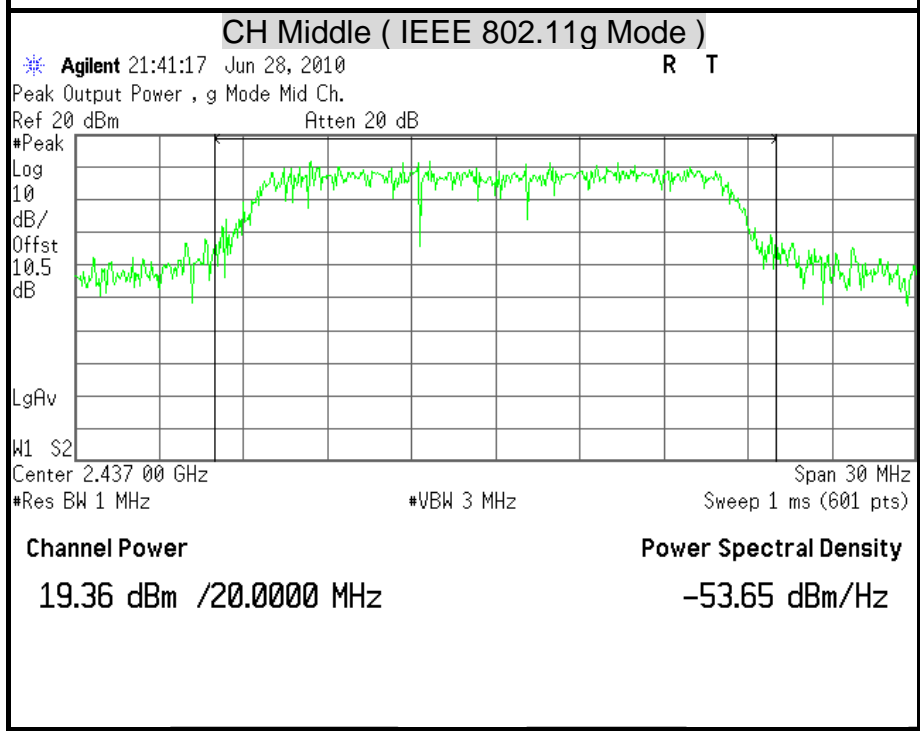
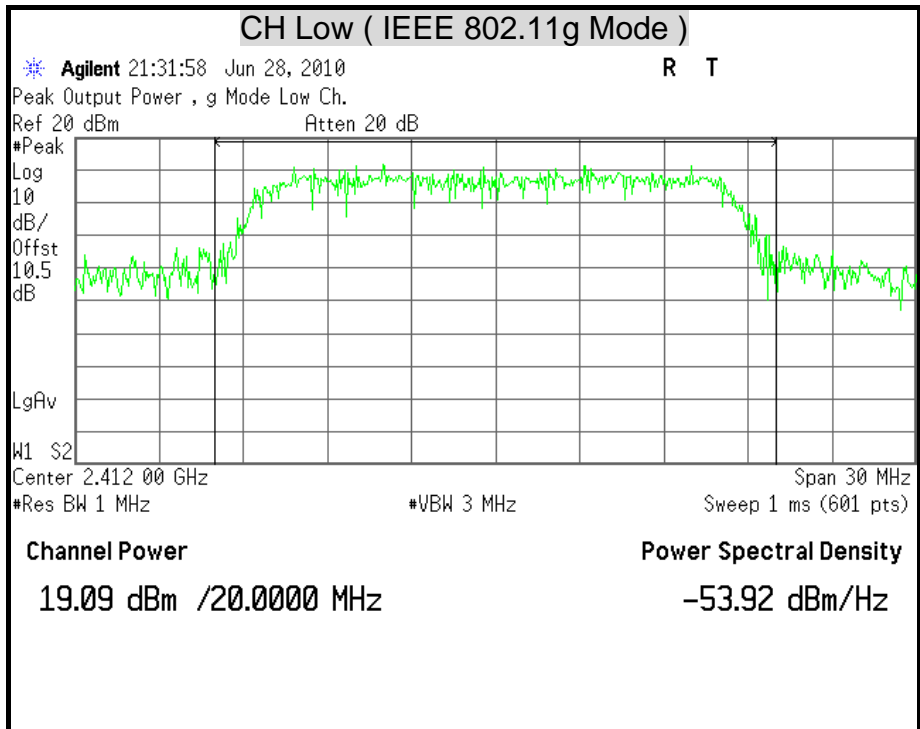

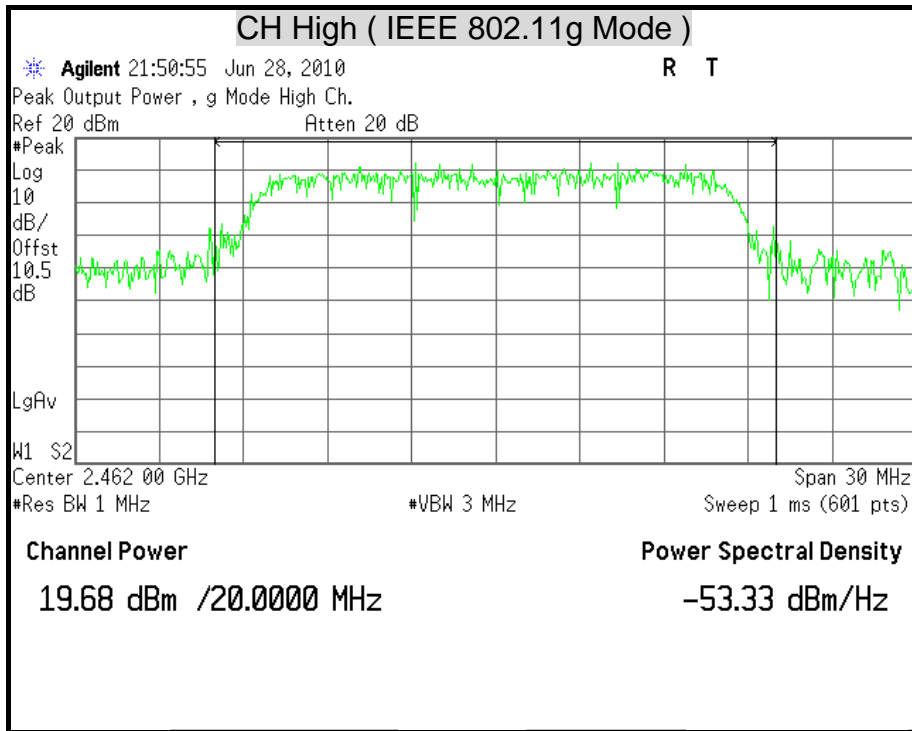



7.3 AVERAGE POWER

LIMITS

None; for reporting purposes only.

TEST EQUIPMENT

Name of Equipment	Manufacturer	Model	Serial Number	Calibration Due
Spectrum Analyzer	AGILENT	E4446A	MY43360132	06/20/2011
Spectrum Analyzer	AGILENT	E4446A	MY46180323	05/02/2011

Remark: Each piece of equipment is scheduled for calibration once a year.

TEST SETUP



TEST PROCEDURE

The transmitter output is connected to a spectrum analyzer.



TEST RESULTS

IEEE 802.11b Mode

Channel	Channel Frequency (MHz)	Average Power Output (dBm)
Low	2412	17.55
Middle	2437	18.79
High	2462	18.97

Remark:

1. At final test to get the worst-case emission at 1Mbps.
2. The cable assembly insertion loss of 10.5dB (including 10 dB pad and 0.5 dB cable) was Entered as an offset in the spectrum analyzer to allow for direct reading of power.

IEEE 802.11g Mode

Channel	Channel Frequency (MHz)	Average Power Output (dBm)
Low	2412	15.38
Middle	2437	15.61
High	2462	15.67

Remark:

1. At final test to get the worst-case emission at 6Mbps.
2. The cable assembly insertion loss of 10.5dB (including 10 dB pad and 0.5 dB cable) was Entered as an offset in the spectrum analyzer to allow for direct reading of power.



7.4 POWER SPECTRAL DENSITY

LIMITS

§ 15.247(e) For digitally modulated systems, the power spectral density conducted from the intentional radiator to the antenna shall not greater than 8 dBm in any 3 kHz band during any time interval of continuous transmission.

TEST EQUIPMENT

Name of Equipment	Manufacturer	Model	Serial Number	Calibration Due
Spectrum Analyzer	AGILENT	E4446A	MY43360132	06/20/2011
Spectrum Analyzer	AGILENT	E4446A	MY46180323	05/02/2011

Remark: Each piece of equipment is scheduled for calibration once a year.

TEST SETUP

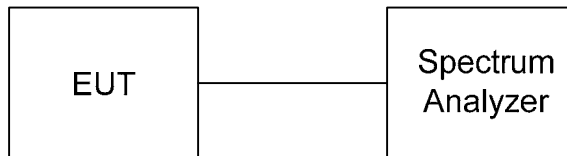

TEST PROCEDURE

The transmitter output was connected to the spectrum analyzer, the bandwidth of the fundamental frequency was measured with the spectrum analyzer using RBW = 3KHz and VBW RBW, set sweep time = span / 3KHz.

The power spectral density was measured and recorded.

The sweep time is allowed to be longer than span / 3KHz for a full response of the mixer in the spectrum analyzer.



TEST RESULTS

IEEE 802.11b Mode

Channel	Channel Frequency (MHz)	Final RF Power Level in 3KHz BW (dBm)	Minimum Limit (dBm)	Pass / Fail
Low	2412	-8.60	8	PASS
Middle	2437	-7.68	8	PASS
High	2462	-7.41	8	PASS

Remark:

1. At final test to get the worst-case emission at 1Mbps.
2. The cable assembly insertion loss of 10.5dB (including 10 dB pad and 0.5 dB cable) was Entered as an offset in the spectrum analyzer to allow for direct reading of power.

IEEE 802.11g Mode

Channel	Channel Frequency (MHz)	Final RF Power Level in 3KHz BW (dBm)	Minimum Limit (dBm)	Pass / Fail
Low	2412	-11.15	8	PASS
Middle	2437	-10.33	8	PASS
High	2462	-9.97	8	PASS

Remark:

1. At final test to get the worst-case emission at 6Mbps.
2. The cable assembly insertion loss of 10.5dB (including 10 dB pad and 0.5 dB cable) was Entered as an offset in the spectrum analyzer to allow for direct reading of power.



POWER SPECTRAL DENSITY

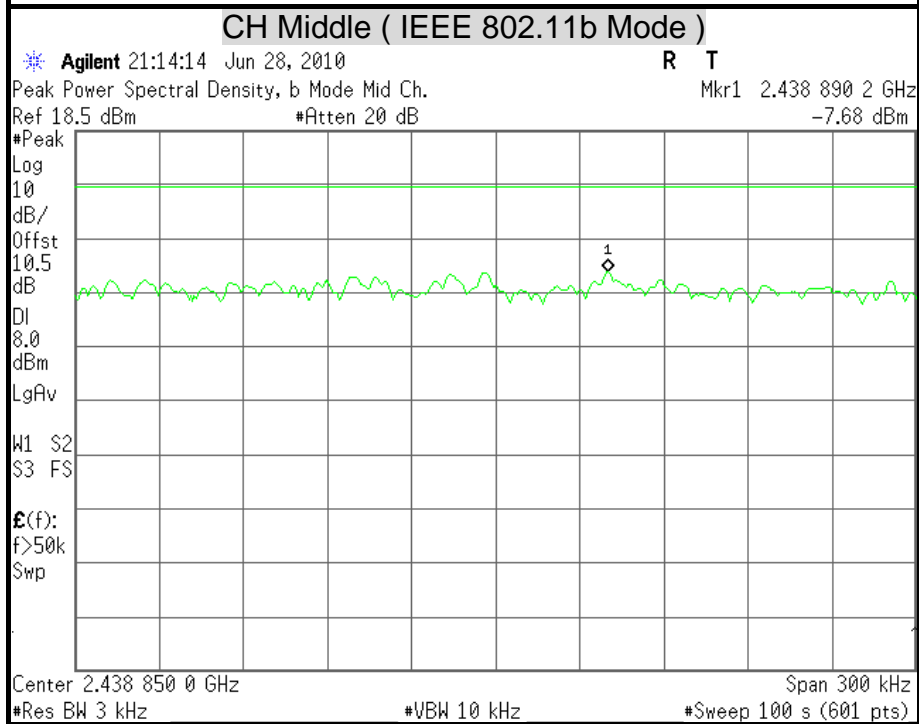
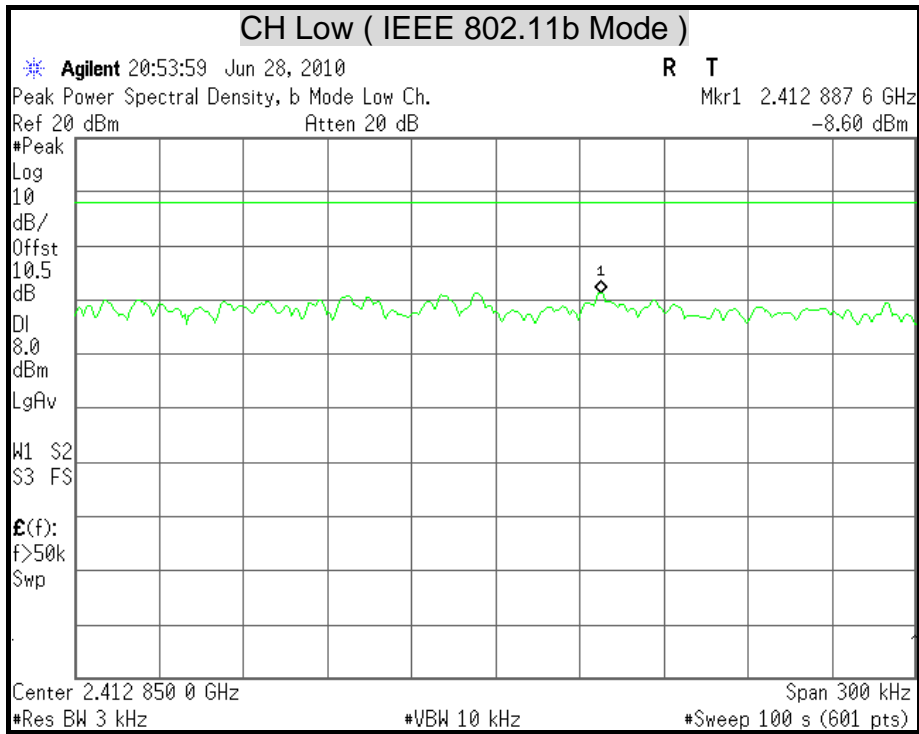

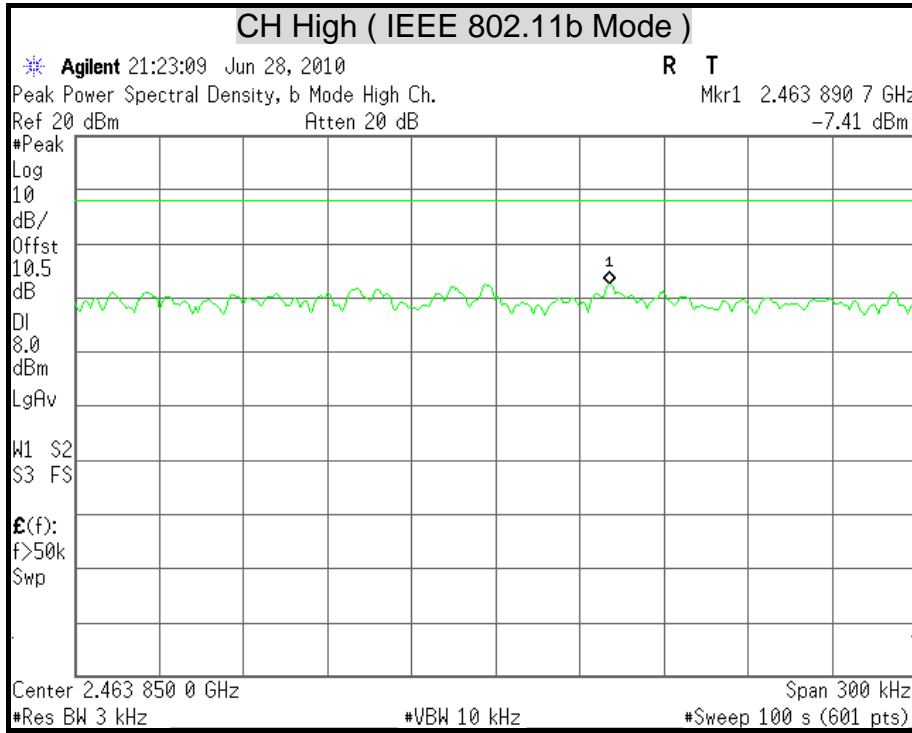

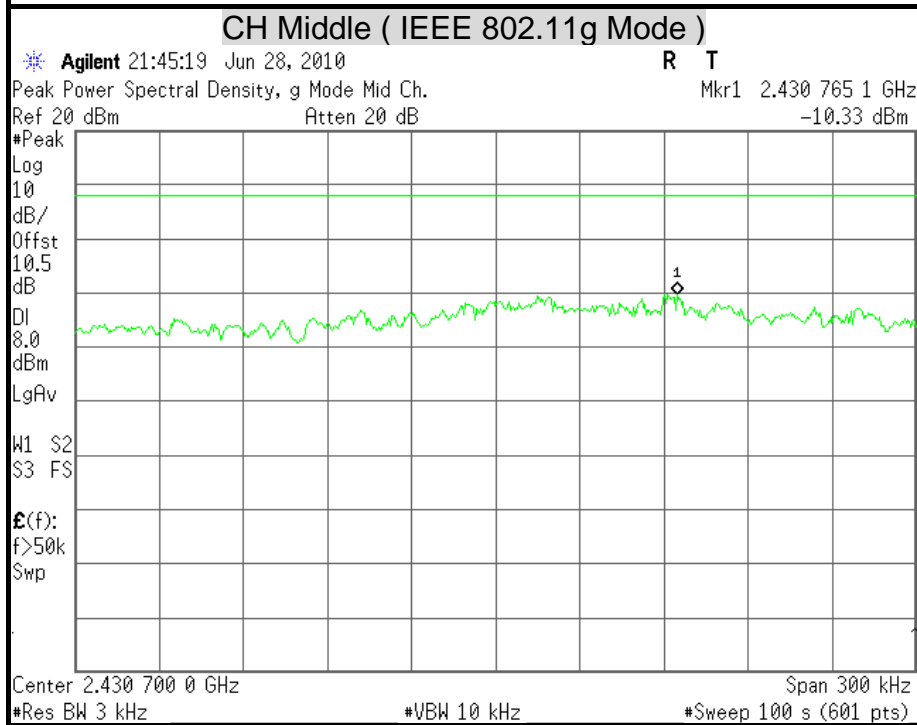
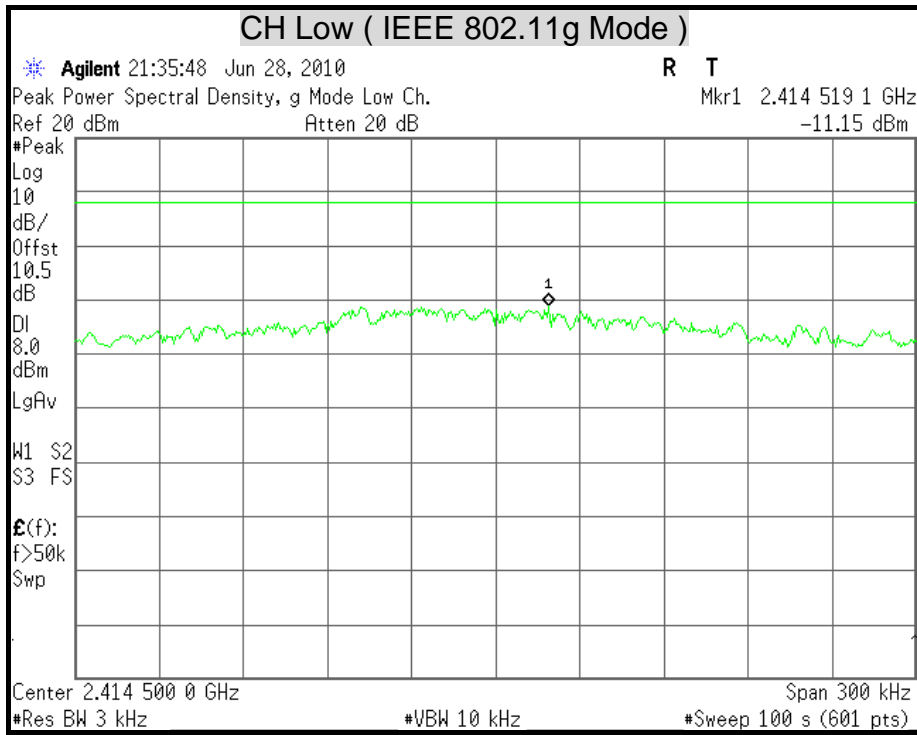



7.5 CONDUCTED SPURIOUS EMISSION

LIMITS

§ 15.247(d) In any 100 kHz bandwidth outside the frequency band in which the spread spectrum intentional radiator is operating, the radio frequency power that is produced by the intentional radiator shall be at least 20 dB below that in the 100 kHz bandwidth within the and that contains the highest level of the desired power, based on either an RF conducted or a radiated measurement. Attenuation below the general limits specified in § 15.209(a) is not required. In addition, radiated emissions which fall in the restricted bands, as defined in § 15.205(a), must also comply with the radiated emission limits specified in § 15.209(a) (see § 15.205(c)).

TEST EQUIPMENT

Name of Equipment	Manufacturer	Model	Serial Number	Calibration Due
Spectrum Analyzer	AGILENT	E4446A	MY43360132	06/20/2011
Spectrum Analyzer	AGILENT	E4446A	MY46180323	05/02/2011

Remark: Each piece of equipment is scheduled for calibration once a year.

TEST SETUP

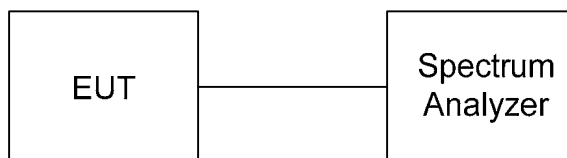

TEST PROCEDURE

The transmitter output is connected to a spectrum analyzer. The resolution bandwidth is set to 100 kHz. The video bandwidth is set to 300 kHz.

The spectrum from 30 MHz to 26 GHz is investigated with the transmitter set to the lowest, middle, and highest channels in the 2.4 GHz band.



TEST RESULTS

OUT-OF-BAND SPURIOUS EMISSIONS-CONDUCTED MEASUREMENT

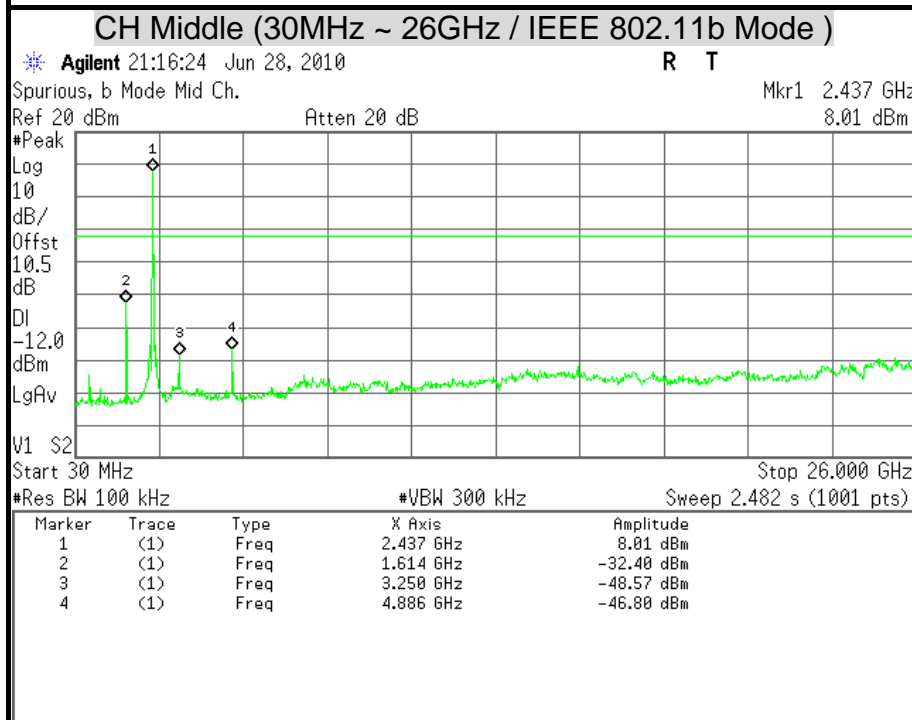
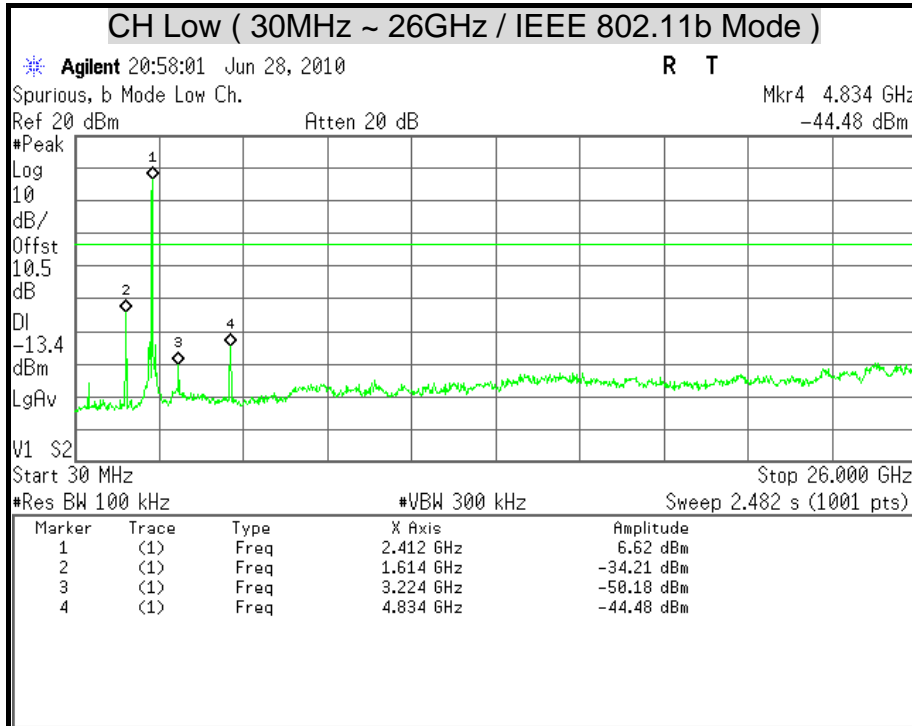

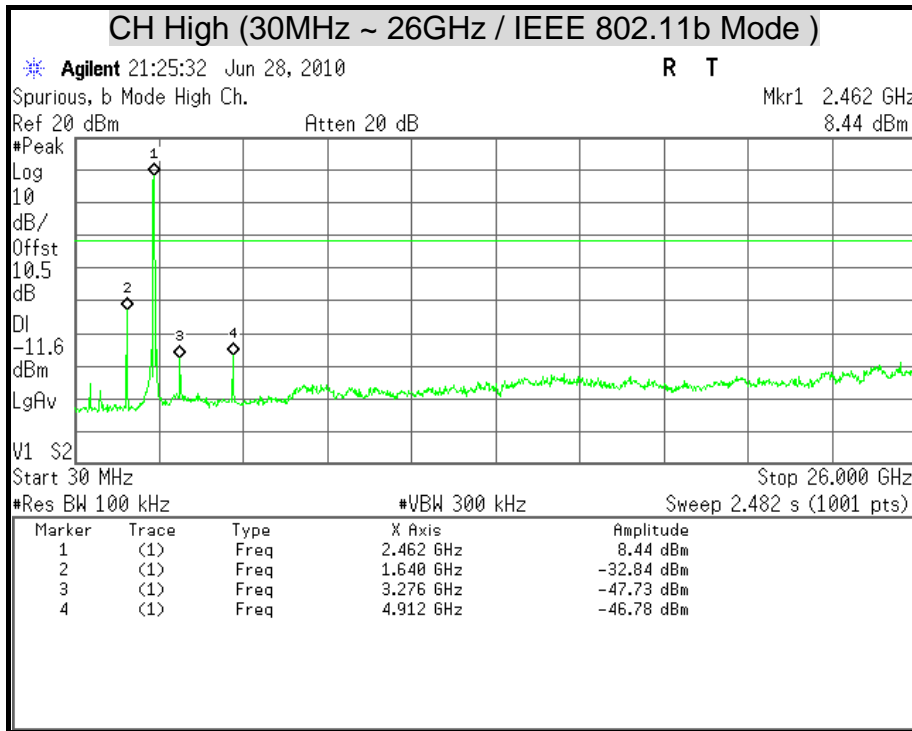

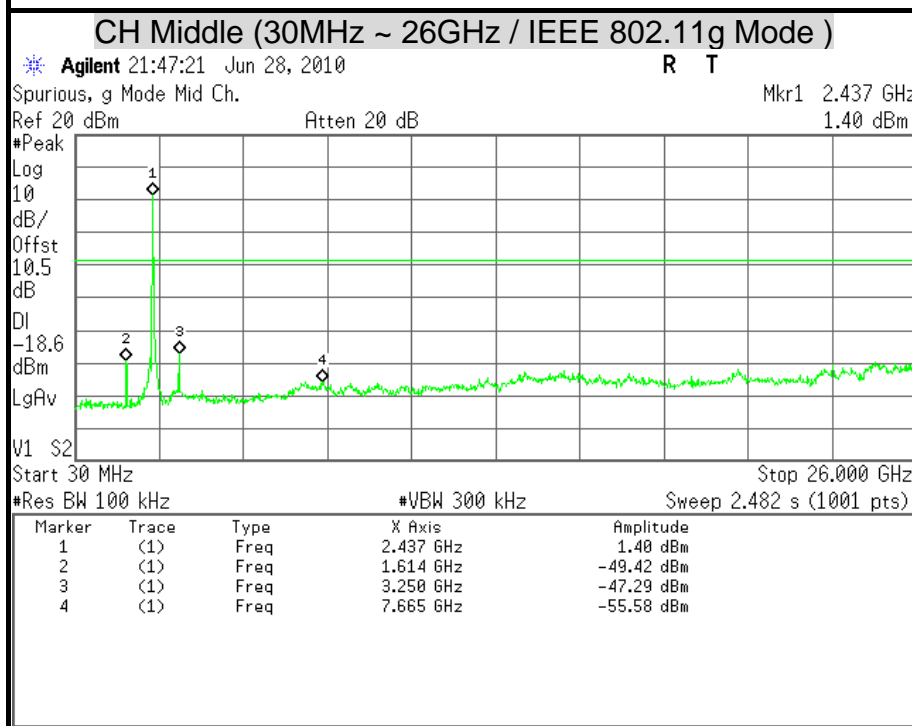
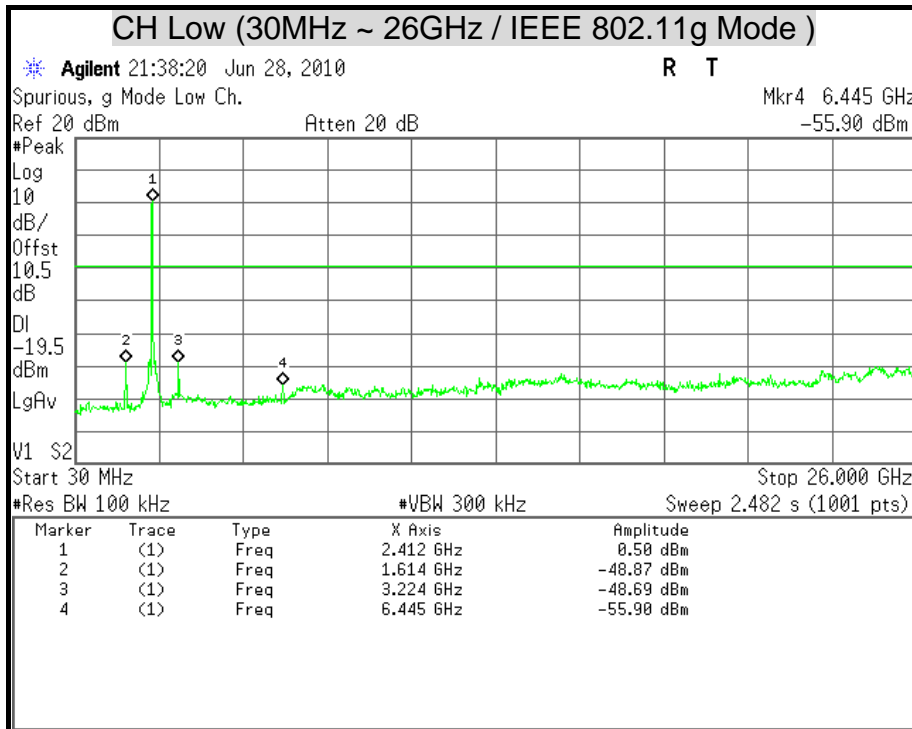

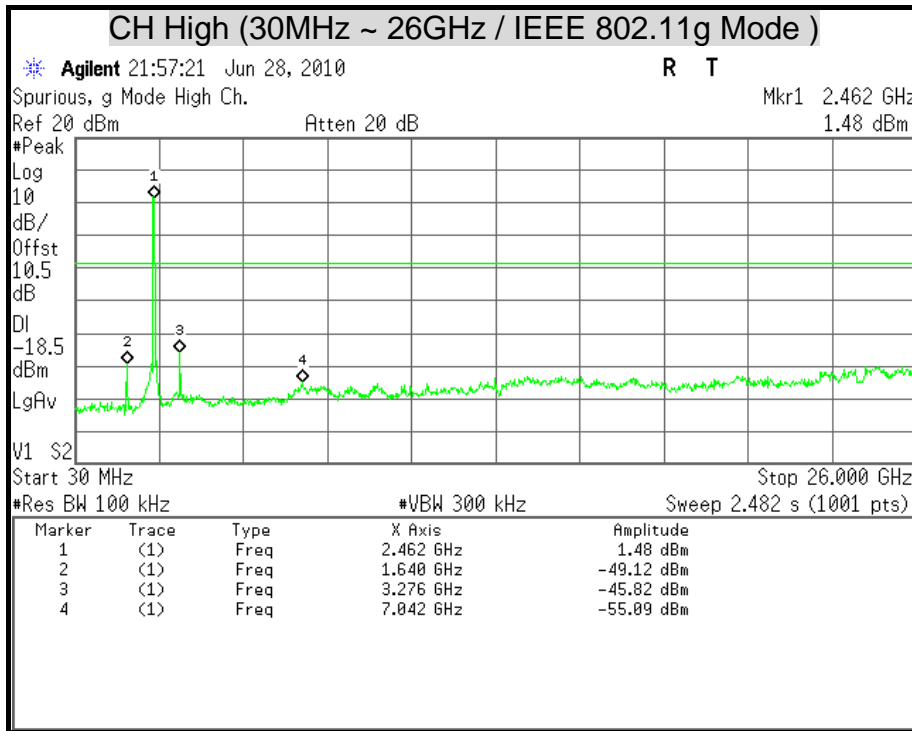



7.6 RADIATED EMISSION

LIMITS

(1) § 15.205 (a) Except as shown in paragraph (d) of this section, only spurious emissions are permitted in any of the frequency bands listed below:

MHz	MHz	MHz	GHz
0.090 - 0.110	16.42 - 16.423	399.9 - 410	4.5 - 5.15
¹ 0.495 - 0.505	16.69475 - 16.69525	608 - 614	5.35 - 5.46
2.1735 - 2.1905	16.80425 - 16.80475	960 - 1240	7.25 - 7.75
4.125 - 4.128	25.5 - 25.67	1300 - 1427	8.025 - 8.5
4.17725 - 4.17775	37.5 - 38.25	1435 - 1626.5	9.0 - 9.2
4.20725 - 4.20775	73 - 74.6	1645.5 - 1646.5	9.3 - 9.5
6.215 - 6.218	74.8 - 75.2	1660 -1710	10.6 -12.7
6.26775 - 6.26825	108 -121.94	1718.8 - 1722.2	13.25 -13.4
6.31175 - 6.31225	123 - 138	2200 - 2300	14.47 – 14.5
8.291 - 8.294	149.9 - 150.05	2310 - 2390	15.35 -16.2
8.362 - 8.366	156.52475 - 156.52525	2483.5 - 2500	17.7 - 21.4
8.37625 - 8.38675	156.7 - 156.9	2655 - 2900	22.01 - 23.12
8.41425 - 8.41475	162.0125 - 167.17	3260 - 3267	23.6 - 24.0
12.29 - 12.293	167.72 - 173.2	3332 - 3339	31.2 - 31.8
12.51975 - 12.52025	240 - 285	3345.8 - 3338	36.43 - 36.5
12.57675 - 12.57725	322 -335.4	3600 - 4400	(²)
13.36 - 13.41			

Remark:

1. ¹ Until February 1, 1999, this restricted band shall be 0.490-0.510 MHz.
2. ² Above 38.6

(2) § 15.205 (b) Except as provided in paragraphs (d) and (e), the field strength of emissions appearing within these frequency bands shall not exceed the limits shown in Section 15.209. At frequencies equal to or less than 1000 MHz, compliance with the limits in Section 15.209 shall be demonstrated using measurement instrumentation employing a CISPR quasi-peak detector. Above 1000 MHz, compliance with the emission limits in Section 15.209 shall be demonstrated based on the average value of the measured emissions. The provisions in Section 15.35 apply to these measurements.



(3) According to § 15.209 (a) Except as provided elsewhere in this Subpart, the emissions from an intentional radiator shall not exceed the field strength levels specified in the following table :

Frequency (MHz)	Field Strength (microvolts/meter)	Measurement Distance (meters)
0.009 – 0.490	2400/F(KHz)	300
0.490 – 1.705	24000/F(KHz)	30
1.705 – 30.0	30	30
30 - 88	100 **	3
88 - 216	150 **	3
216 - 960	200 **	3
Above 960	500	3

Remark: **Except as provided in paragraph (g), fundamental emissions from intentional radiators operating under this Section shall not be located in the frequency bands 54-72 MHz, 76-88 MHz, 174-216 MHz or 470-806 MHz. However, operation within these frequency bands is permitted under other sections of this Part, e.g., Sections 15.231 and 15.241.

(4) According to § 15.209 (b) In the emission table above, the tighter limit applies at the band edges.

TEST EQUIPMENT

966Chamber_A

Name of Equipment	Manufacture	Model	Serial Number	Calibration Due
Spectrum Analyzer	Agilent	E4446A	MY43360132	06/20/2011
EMI Test Receiver	ROHDE & SCHWARZ	ESCI	100221	05/03/2011
Bilog Antenna	SCHWARZBECK	VULB 9168	9168-249	11/12/2010
Double-Ridged Waveguide Horn	ETS LINDGREN	3117	00078732	06/30/2010
Pre-Amplifier	Agilent	8449B	3008A01471	08/02/2010
Pre-Amplifier	EM	EM30265	07032611	11/09/2010
RF Coaxial Cable	HUBER-SUHNER	SUCOFLEX 104PEA	SN31347	07/21/2010
RF Coaxial Cable	HUBER-SUHNER	SUCOFLEX 104PEA	SN31350	07/21/2010
RF Coaxial Cable	HUBER-SUHNER	SUCOFLEX 104PEA	SN31355	07/21/2010
LOOP ANTENNA	EMCO	6502	2356	05/28/2010
Notch Filters Band Reject	Micro-Tronics	BRM05702-01	009	N.C.R

Remark: 1. Each piece of equipment is scheduled for calibration once a year.
2. N.C.R = No Calibration Request.

TEST SETUP

The diagram below shows the test setup that is utilized to make the measurements for emission from below 1GHz.

9kHz ~ 30MHz

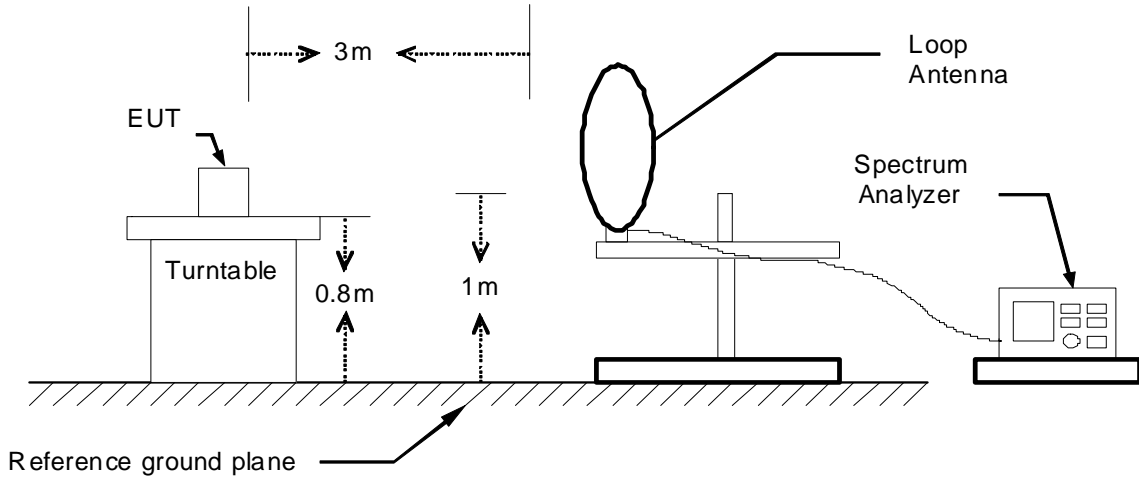

30MHz ~ 1GHz

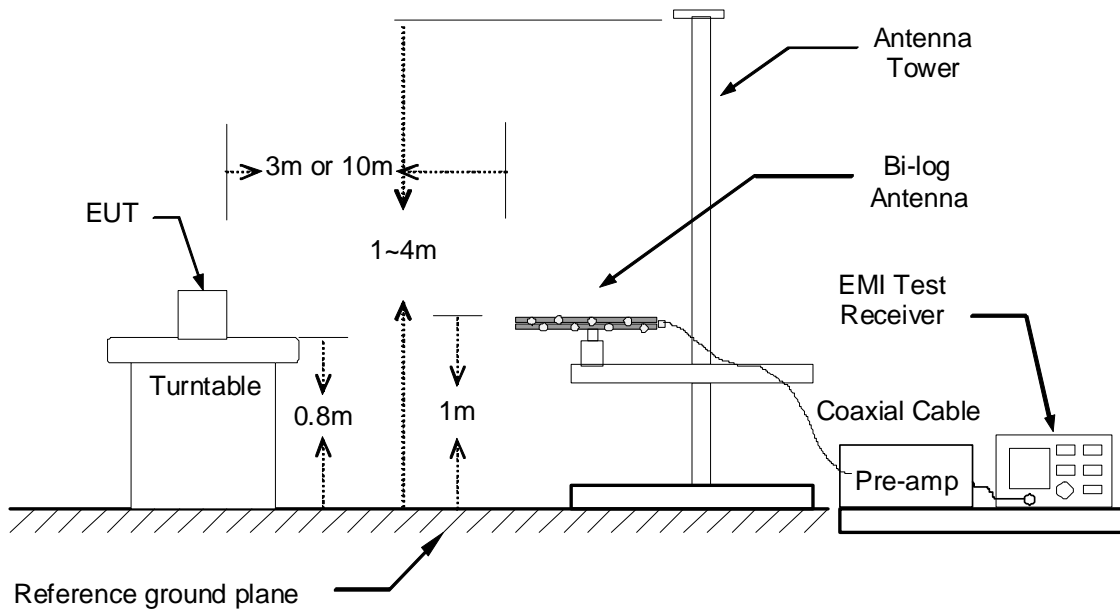

The diagram below shows the test setup that is utilized to make the measurements for emission above 1GHz.

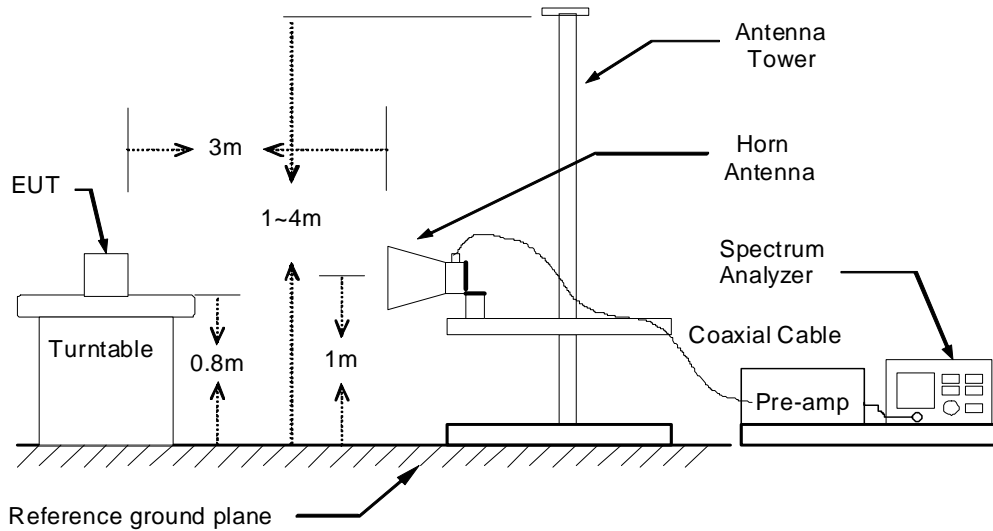

TEST PROCEDURE

1. The EUT was placed on the top of a rotating table 0.8 meters above the ground at a 10 meter open area test site. The table was rotated 360 degrees to determine the position of the highest radiation.
2. While measuring the radiated emission below 1GHz, the EUT was set 3 meters away from the interference-receiving antenna, which was mounted on the top of a variable-height antenna tower. While measuring the radiated emission above 1GHz, the EUT was set 3 meters away from the interference-receiving antenna.
3. The antenna is a broadband antenna, and its height is varied from one meter to four meters above the ground to determine the maximum value of the field strength. Both horizontal and vertical polarization of the antenna are set to make the measurement.
4. For each suspected emission, the EUT was arranged to its worst case and then the antenna was tuned to heights from 1 meter to 4 meters and the table was turned from 0 degrees to 360 degrees to find the maximum reading.
5. The test-receiver system was set to Peak Detect Function and Specified Bandwidth with Maximum Hold Mode.
6. If the emission level of the EUT in peak mode was 10 dB lower than the limit specified, then testing could be stopped and the peak values of the EUT would be reported. Otherwise the emissions that did not have 10 dB margin would be re-tested one by one using peak, quasi-peak or average method as specified and then reported in a data sheet.

Remark :

1. The resolution bandwidth and video bandwidth of test receiver/spectrum analyzer is 120 KHz for Peak detection (PK) and Quasi-peak detection (QP) at frequency below 1GHz.
2. The resolution bandwidth and video bandwidth of test receiver/spectrum analyzer is 1 MHz for Peak detection and frequency above 1GHz.
3. The resolution bandwidth of test receiver/spectrum analyzer is 1 MHz and the video bandwidth is 10 Hz for Average detection (AV) at frequency above 1GHz.



TEST RESULTS

Below 1 GHz (9kHz ~ 30MHz)

No emission found between lowest internal used/generated frequency to 30MHz.

Below 1 GHz (30MHz ~ 1GHz)

Product Name	Wireless IP CAM	Test By	Rick Lin
Model	F5115	Test Date	2010/06/27
Test Mode	Normal operating (worst-case)	TEMP & Humidity	26°C, 63%

966 Chamber_A at 3Meter / Horizontal						
Frequency (MHz)	Reading (dBµV)	Correction Factor (dB/m)	Result (dBµV/m)	Limit (dBµV/m)	Margin (dB)	Remark
49.40	41.57	-9.43	32.14	40.00	-7.86	Peak
134.76	47.07	-11.02	36.05	43.50	-7.45	Peak
319.06	46.39	-8.29	38.10	46.00	-7.90	Peak
431.58	46.84	-5.16	41.68	46.00	-4.32	Peak
485.90	45.94	-4.00	41.93	46.00	-4.07	Peak
540.22	42.53	-2.74	39.79	46.00	-6.21	Peak
593.57	43.69	-1.46	42.23	46.00	-3.77	Peak
917.55	34.10	4.24	38.35	46.00	-7.65	Peak

966 Chamber_A at 3Meter / Vertical						
Frequency (MHz)	Reading (dBµV)	Correction Factor (dB/m)	Result (dBµV/m)	Limit (dBµV/m)	Margin (dB)	Remark
37.76	44.90	-10.44	34.46	40.00	-5.54	QP
76.56	49.73	-13.76	35.97	40.00	-4.03	Peak
320.03	47.87	-8.26	39.61	46.00	-6.39	Peak
431.58	45.33	-5.16	40.17	46.00	-5.83	Peak
480.08	45.63	-4.13	41.51	46.00	-4.49	Peak
485.90	48.90	-4.00	44.90	46.00	-1.10	QP
540.22	43.15	-2.74	40.41	46.00	-5.59	Peak
593.57	44.01	-1.46	42.55	46.00	-3.45	Peak

Remark:

1. Quasi-peak test would be performed if the peak result were greater than the quasi-peak limit.
2. Data of measurement within this frequency range shown " --- " in the table above means the reading of emissions are attenuated more than 20dB below the permissible limits or the field strength is too small to be measured.
3. Correction Factor (dB/m) = Antenna Factor (dB/m) + Cable Loss (dB) – PreAmp.Gain (dB)
4. Result (dBuV/m) = Reading (dBuV) + Correction Factor (dB/m)
5. Margin (dB) = Remark result (dBuV/m) - Quasi-peak limit (dBuV/m).



Above 1 GHz

Product Name	Wireless IP CAM	Test By	Rick Lin
Model	F5115	Test Date	2010/06/27
Test Mode	IEEE 802.11b TX / CH Low	TEMP & Humidity	26°C, 63%

966 Chamber_A at 3Meter / Horizontal									
Frequency (MHz)	Reading-PK (dBuV)	Reading-AV (dBuV)	Correction Factor (dB/m)	Result-PK (dBuV/m)	Result-AV (dBuV/m)	Limit-PK (dBuV/m)	Limit-AV (dBuV/m)	Margin (dB)	Remark
1242.00	49.49	---	-3.95	45.54	---	74.00	54.00	-8.46	Peak
1458.00	50.45	---	-3.22	47.23	---	74.00	54.00	-6.77	Peak
1566.00	51.73	---	-2.44	49.29	---	74.00	54.00	-4.71	Peak
1674.00	50.56	---	-1.41	49.14	---	74.00	54.00	-4.86	Peak
1728.00	48.74	---	-0.90	47.84	---	74.00	54.00	-6.16	Peak
1782.00	55.30	50.34	-0.38	54.92	49.96	74.00	54.00	-4.04	AVG
2412.00	92.27	---	2.31	94.58	---	---	---	---	Carrier
3517.50	42.58	---	4.31	46.89	---	74.00	54.00	-7.11	Peak
4822.50	47.62	43.24	7.08	54.70	50.32	74.00	54.00	-3.68	AVG
6480.00	41.43	---	9.68	51.11	---	74.00	54.00	-2.89	Peak

966 Chamber_A at 3Meter / Vertical									
Frequency (MHz)	Reading-PK (dBuV)	Reading-AV (dBuV)	Correction Factor (dB/m)	Result-PK (dBuV/m)	Result-AV (dBuV/m)	Limit-PK (dBuV/m)	Limit-AV (dBuV/m)	Margin (dB)	Remark
1782.00	46.72	---	-0.38	46.34	---	74.00	54.00	-7.66	Peak
1998.00	46.01	---	1.68	47.69	---	74.00	54.00	-6.31	Peak
2376.00	46.97	---	2.25	49.22	---	74.00	54.00	-4.78	Peak
2412.00	87.95	---	2.30	90.25	---	---	---	---	Carrier
4822.50	47.69	43.40	7.08	54.77	50.48	74.00	54.00	-3.52	AVG
6757.50	44.69	34.17	10.03	54.72	44.20	74.00	54.00	-9.80	AVG
9645.00	47.11	40.29	12.99	60.10	53.28	74.00	54.00	-0.72	AVG
12645.00	41.59	28.23	18.47	60.06	46.70	74.00	54.00	-7.30	AVG

Remark:

1. Measuring frequencies from 1 GHz to the 10th harmonic of highest fundamental frequency.
2. Average test would be performed if the peak result were greater than the average limit.
3. Data of measurement within this frequency range shown " --- " in the table above means the reading of emissions are attenuated more than 20dB below the permissible limits or the field strength is too small to be measured.
4. Measurements above show only up to 6 maximum emissions noted, or would be lesser, with " N/A " remark, if no specific emissions from the EUT are recorded (ie: margin>20dB from the applicable limit) and considered that's already beyond the background noise floor.
5. In any 100 kHz bandwidth outside the frequency band in which the spread spectrum or digitally modulated intentional radiator is operating, the radio frequency power that is produced by the intentional radiator shall be at least 20 dB below that in the 100 kHz bandwidth within the band that contains the highest level of the desired power, based on either an RF conducted or a radiated measurement, provided the transmitter demonstrates compliance with the peak conducted power limits. If the transmitter complies with the conducted power limits based on the use of RMS averaging over a time interval, as permitted under paragraph (b)(3) of this section, the attenuation required under this paragraph shall be 30 dB instead of 20 dB.
6. Result = Reading + Correction Factor
Margin = Result - Limit
Remark Peak = Result(PK) - Limit(AV)
Remark AVG = Result(AV) - Limit(AV)



Product Name	Wireless IP CAM	Test By	Rick Lin
Model	F5115	Test Date	2010/06/27
Test Mode	IEEE 802.11b TX / CH Middle	TEMP & Humidity	26°C, 63%

966 Chamber_A at 3Meter / Horizontal									
Frequency (MHz)	Reading-PK (dBuV)	Reading-AV (dBuV)	Correction Factor (dB/m)	Result-PK (dBuV/m)	Result-AV (dBuV/m)	Limit-PK (dBuV/m)	Limit-AV (dBuV/m)	Margin (dB)	Remark
1566.00	51.55	---	-2.44	49.11	---	74.00	54.00	-4.89	Peak
1674.00	50.85	---	-1.41	49.43	---	74.00	54.00	-4.57	Peak
1728.00	50.03	---	-0.90	49.13	---	74.00	54.00	-4.87	Peak
1782.00	52.12	---	-0.38	51.74	---	74.00	54.00	-2.26	Peak
2437.00	93.01	---	2.34	95.36	---	---	---	---	Carrier
3367.50	42.75	---	4.04	46.79	---	74.00	54.00	-7.21	Peak
4875.00	47.47	42.87	7.11	54.58	49.98	74.00	54.00	-4.02	AVG
7987.50	43.53	30.83	11.08	54.61	41.91	74.00	54.00	-12.09	AVG

966 Chamber_A at 3Meter / Vertical									
Frequency (MHz)	Reading-PK (dBuV)	Reading-AV (dBuV)	Correction Factor (dB/m)	Result-PK (dBuV/m)	Result-AV (dBuV/m)	Limit-PK (dBuV/m)	Limit-AV (dBuV/m)	Margin (dB)	Remark
1458.00	50.00	---	-3.22	46.78	---	74.00	54.00	-7.22	Peak
1566.00	51.57	---	-2.44	49.13	---	74.00	54.00	-4.87	Peak
1674.00	50.64	---	-1.41	49.23	---	74.00	54.00	-4.77	Peak
1728.00	49.26	---	-0.90	48.36	---	74.00	54.00	-5.64	Peak
1782.00	52.13	---	-0.38	51.75	---	74.00	54.00	-2.25	Peak
2437.00	92.93	---	2.34	95.28	---	---	---	---	Carrier
3247.50	42.49	---	3.82	46.31	---	74.00	54.00	-7.69	Peak
4875.00	47.74	42.54	7.11	54.85	49.65	74.00	54.00	-4.35	AVG
6652.50	41.34	---	9.89	51.23	---	74.00	54.00	-2.77	Peak

Remark:

1. Measuring frequencies from 1 GHz to the 10th harmonic of highest fundamental frequency.
2. Average test would be performed if the peak result were greater than the average limit.
3. Data of measurement within this frequency range shown " --- " in the table above means the reading of emissions are attenuated more than 20dB below the permissible limits or the field strength is too small to be measured.
4. Measurements above show only up to 6 maximum emissions noted, or would be lesser, with " N/A " remark, if no specific emissions from the EUT are recorded (ie: margin>20dB from the applicable limit) and considered that's already beyond the background noise floor.
5. In any 100 kHz bandwidth outside the frequency band in which the spread spectrum or digitally modulated intentional radiator is operating, the radio frequency power that is produced by the intentional radiator shall be at least 20 dB below that in the 100 kHz bandwidth within the band that contains the highest level of the desired power, based on either an RF conducted or a radiated measurement, provided the transmitter demonstrates compliance with the peak conducted power limits. If the transmitter complies with the conducted power limits based on the use of RMS averaging over a time interval, as permitted under paragraph (b)(3) of this section, the attenuation required under this paragraph shall be 30 dB instead of 20 dB.
6. Result = Reading + Correction Factor
Margin = Result - Limit
Remark Peak = Result(PK) - Limit(AV)
Remark AVG = Result(AV) - Limit(AV)



Product Name	Wireless IP CAM	Test By	Rick Lin
Model	F5115	Test Date	2010/06/27
Test Mode	IEEE 802.11b TX / CH High	TEMP & Humidity	26°C, 63%

966 Chamber_A at 3Meter / Horizontal									
Frequency (MHz)	Reading-PK (dBuV)	Reading-AV (dBuV)	Correction Factor (dB/m)	Result-PK (dBuV/m)	Result-AV (dBuV/m)	Limit-PK (dBuV/m)	Limit-AV (dBuV/m)	Margin (dB)	Remark
1458.00	50.67	---	-3.22	47.45	---	74.00	54.00	-6.55	Peak
1566.00	51.68	---	-2.44	49.23	---	74.00	54.00	-4.77	Peak
1674.00	51.40	---	-1.41	49.99	---	74.00	54.00	-4.01	Peak
1728.00	49.89	---	-0.90	49.00	---	74.00	54.00	-5.00	Peak
1782.00	52.24	---	-0.38	51.86	---	74.00	54.00	-2.14	Peak
2462.00	94.02	---	2.38	96.40	---	---	---	---	Carrier
3285.00	43.34	---	3.89	47.23	---	74.00	54.00	-6.77	Peak
4927.50	47.08	42.72	7.14	54.22	49.86	74.00	54.00	-4.14	AVG
6112.50	40.69	---	9.35	50.04	---	74.00	54.00	-3.96	Peak

966 Chamber_A at 3Meter / Vertical									
Frequency (MHz)	Reading-PK (dBuV)	Reading-AV (dBuV)	Correction Factor (dB/m)	Result-PK (dBuV/m)	Result-AV (dBuV/m)	Limit-PK (dBuV/m)	Limit-AV (dBuV/m)	Margin (dB)	Remark
1782.00	46.84	---	-0.38	46.46	---	74.00	54.00	-7.54	Peak
1998.00	46.30	---	1.68	47.98	---	74.00	54.00	-6.02	Peak
2376.00	47.50	---	2.25	49.75	---	74.00	54.00	-4.25	Peak
2462.00	90.10	---	2.38	92.48	---	---	---	---	Carrier
3165.00	44.50	---	3.67	48.17	---	74.00	54.00	-5.83	Peak
4927.50	47.66	41.94	7.14	54.80	49.08	74.00	54.00	-4.92	AVG
6405.00	41.52	---	9.61	51.13	---	74.00	54.00	-2.87	Peak

Remark:

1. Measuring frequencies from 1 GHz to the 10th harmonic of highest fundamental frequency.
2. Average test would be performed if the peak result were greater than the average limit.
3. Data of measurement within this frequency range shown " --- " in the table above means the reading of emissions are attenuated more than 20dB below the permissible limits or the field strength is too small to be measured.
4. Measurements above show only up to 6 maximum emissions noted, or would be lesser, with " N/A " remark, if no specific emissions from the EUT are recorded (ie: margin>20dB from the applicable limit) and considered that's already beyond the background noise floor.
5. In any 100 kHz bandwidth outside the frequency band in which the spread spectrum or digitally modulated intentional radiator is operating, the radio frequency power that is produced by the intentional radiator shall be at least 20 dB below that in the 100 kHz bandwidth within the band that contains the highest level of the desired power, based on either an RF conducted or a radiated measurement, provided the transmitter demonstrates compliance with the peak conducted power limits. If the transmitter complies with the conducted power limits based on the use of RMS averaging over a time interval, as permitted under paragraph (b)(3) of this section, the attenuation required under this paragraph shall be 30 dB instead of 20 dB.
6. Result = Reading + Correction Factor
Margin = Result - Limit
Remark Peak = Result(PK) - Limit(AV)
Remark AVG = Result(AV) - Limit(AV)



Product Name	Wireless IP CAM	Test By	Rick Lin
Model	F5115	Test Date	2010/06/27
Test Mode	IEEE 802.11g TX / CH Low	TEMP & Humidity	26°C, 63%

966 Chamber_A at 3Meter / Horizontal									
Frequency (MHz)	Reading-PK (dBuV)	Reading-AV (dBuV)	Correction Factor (dB/m)	Result-PK (dBuV/m)	Result-AV (dBuV/m)	Limit-PK (dBuV/m)	Limit-AV (dBuV/m)	Margin (dB)	Remark
1458.00	50.33	---	-3.22	47.12	---	74.00	54.00	-6.88	Peak
1566.00	51.00	---	-2.44	48.56	---	74.00	54.00	-5.44	Peak
1674.00	50.60	---	-1.41	49.19	---	74.00	54.00	-4.81	Peak
1728.00	50.17	---	-0.90	49.27	---	74.00	54.00	-4.73	Peak
1782.00	52.10	---	-0.38	51.72	---	74.00	54.00	-2.28	Peak
2412.00	92.95	---	2.31	95.27	---	---	---	---	Carrier
4822.50	42.11	---	7.08	49.19	---	74.00	54.00	-4.81	Peak
5790.00	40.87	---	8.88	49.75	---	74.00	54.00	-4.25	Peak
6960.00	41.08	---	10.28	51.36	---	74.00	54.00	-2.64	Peak

966 Chamber_A at 3Meter / Vertical									
Frequency (MHz)	Reading-PK (dBuV)	Reading-AV (dBuV)	Correction Factor (dB/m)	Result-PK (dBuV/m)	Result-AV (dBuV/m)	Limit-PK (dBuV/m)	Limit-AV (dBuV/m)	Margin (dB)	Remark
1374.00	49.57	---	-3.50	46.07	---	74.00	54.00	-7.93	Peak
1998.00	46.48	---	1.68	48.17	---	74.00	54.00	-5.83	Peak
2106.00	46.47	---	1.86	48.33	---	74.00	54.00	-5.67	Peak
2412.00	89.40	---	2.30	91.70	---	---	---	---	Carrier
3772.50	42.02	---	4.74	46.76	---	74.00	54.00	-7.24	Peak
5730.00	41.26	---	8.78	50.03	---	74.00	54.00	-3.97	Peak
6435.00	41.66	---	9.64	51.30	---	74.00	54.00	-2.70	Peak

Remark:

1. Measuring frequencies from 1 GHz to the 10th harmonic of highest fundamental frequency.
2. Average test would be performed if the peak result were greater than the average limit.
3. Data of measurement within this frequency range shown " --- " in the table above means the reading of emissions are attenuated more than 20dB below the permissible limits or the field strength is too small to be measured.
4. Measurements above show only up to 6 maximum emissions noted, or would be lesser, with " N/A " remark, if no specific emissions from the EUT are recorded (ie: margin>20dB from the applicable limit) and considered that's already beyond the background noise floor.
5. In any 100 kHz bandwidth outside the frequency band in which the spread spectrum or digitally modulated intentional radiator is operating, the radio frequency power that is produced by the intentional radiator shall be at least 20 dB below that in the 100 kHz bandwidth within the band that contains the highest level of the desired power, based on either an RF conducted or a radiated measurement, provided the transmitter demonstrates compliance with the peak conducted power limits. If the transmitter complies with the conducted power limits based on the use of RMS averaging over a time interval, as permitted under paragraph (b)(3) of this section, the attenuation required under this paragraph shall be 30 dB instead of 20 dB.
6. Result = Reading + Correction Factor
Margin = Result - Limit
Remark Peak = Result(PK) - Limit(AV)
Remark AVG = Result(AV) - Limit(AV)



Product Name	Wireless IP CAM	Test By	Rick Lin
Model	F5115	Test Date	2010/06/27
Test Mode	IEEE 802.11g TX / CH Middle	TEMP & Humidity	26°C, 63%

966 Chamber_A at 3Meter / Horizontal									
Frequency (MHz)	Reading-PK (dBuV)	Reading-AV (dBuV)	Correction Factor (dB/m)	Result-PK (dBuV/m)	Result-AV (dBuV/m)	Limit-PK (dBuV/m)	Limit-AV (dBuV/m)	Margin (dB)	Remark
1458.00	50.36	---	-3.22	47.14	---	74.00	54.00	-6.86	Peak
1566.00	51.23	---	-2.44	48.79	---	74.00	54.00	-5.21	Peak
1674.00	51.05	---	-1.41	49.64	---	74.00	54.00	-4.36	Peak
1728.00	49.50	---	-0.90	48.60	---	74.00	54.00	-5.40	Peak
1782.00	52.12	---	-0.38	51.73	---	74.00	54.00	-2.27	Peak
2437.00	92.43	---	2.34	94.77	---	---	---	---	Carrier
3892.50	42.48	---	4.94	47.42	---	74.00	54.00	-6.58	Peak
5610.00	41.41	---	8.57	49.98	---	74.00	54.00	-4.02	Peak
6750.00	40.94	---	10.02	50.96	---	74.00	54.00	-3.04	Peak

966 Chamber_A at 3Meter / Vertical									
Frequency (MHz)	Reading-PK (dBuV)	Reading-AV (dBuV)	Correction Factor (dB/m)	Result-PK (dBuV/m)	Result-AV (dBuV/m)	Limit-PK (dBuV/m)	Limit-AV (dBuV/m)	Margin (dB)	Remark
1114.00	51.22	---	-4.38	46.84	---	74.00	54.00	-7.16	Peak
1782.00	46.29	---	-0.38	45.90	---	74.00	54.00	-8.10	Peak
2376.00	46.90	---	2.25	49.15	---	74.00	54.00	-4.85	Peak
2437.00	89.52	---	2.35	91.87	---	---	---	---	Carrier
3322.50	42.65	---	3.96	46.60	---	74.00	54.00	-7.40	Peak
4687.50	40.94	---	7.01	47.96	---	74.00	54.00	-6.04	Peak
6187.50	40.88	---	9.42	50.30	---	74.00	54.00	-3.70	Peak

Remark:

1. Measuring frequencies from 1 GHz to the 10th harmonic of highest fundamental frequency.
2. Average test would be performed if the peak result were greater than the average limit.
3. Data of measurement within this frequency range shown " --- " in the table above means the reading of emissions are attenuated more than 20dB below the permissible limits or the field strength is too small to be measured.
4. Measurements above show only up to 6 maximum emissions noted, or would be lesser, with " N/A " remark, if no specific emissions from the EUT are recorded (ie: margin>20dB from the applicable limit) and considered that's already beyond the background noise floor.
5. In any 100 kHz bandwidth outside the frequency band in which the spread spectrum or digitally modulated intentional radiator is operating, the radio frequency power that is produced by the intentional radiator shall be at least 20 dB below that in the 100 kHz bandwidth within the band that contains the highest level of the desired power, based on either an RF conducted or a radiated measurement, provided the transmitter demonstrates compliance with the peak conducted power limits. If the transmitter complies with the conducted power limits based on the use of RMS averaging over a time interval, as permitted under paragraph (b)(3) of this section, the attenuation required under this paragraph shall be 30 dB instead of 20 dB.
6. Result = Reading + Correction Factor
Margin = Result - Limit
Remark Peak = Result(PK) - Limit(AV)
Remark AVG = Result(AV) - Limit(AV)



Product Name	Wireless IP CAM	Test By	Rick Lin
Model	F5115	Test Date	2010/06/27
Test Mode	IEEE 802.11g TX / CH High	TEMP & Humidity	26°C, 63%

966 Chamber_A at 3Meter / Horizontal

Frequency (MHz)	Reading-PK (dBuV)	Reading-AV (dBuV)	Correction Factor (dB/m)	Result-PK (dBuV/m)	Result-AV (dBuV/m)	Limit-PK (dBuV/m)	Limit-AV (dBuV/m)	Margin (dB)	Remark
1566.00	51.16	---	-2.44	48.72	---	74.00	54.00	-5.28	Peak
1674.00	51.18	---	-1.41	49.77	---	74.00	54.00	-4.23	Peak
1728.00	49.23	---	-0.90	48.33	---	74.00	54.00	-5.67	Peak
1782.00	52.00	---	-0.38	51.62	---	74.00	54.00	-2.38	Peak
2106.00	47.04	---	1.86	48.90	---	74.00	54.00	-5.10	Peak
2462.00	93.40	---	2.37	95.77	---	---	---	---	Carrier
3285.00	43.24	---	3.89	47.13	---	74.00	54.00	-6.87	Peak
5737.50	41.25	---	8.79	50.04	---	74.00	54.00	-3.96	Peak
6862.50	40.65	---	10.16	50.81	---	74.00	54.00	-3.19	Peak

966 Chamber_A at 3Meter / Vertical

Frequency (MHz)	Reading-PK (dBuV)	Reading-AV (dBuV)	Correction Factor (dB/m)	Result-PK (dBuV/m)	Result-AV (dBuV/m)	Limit-PK (dBuV/m)	Limit-AV (dBuV/m)	Margin (dB)	Remark
1782.00	46.07	---	-0.38	45.69	---	74.00	54.00	-8.31	Peak
2322.00	45.20	---	2.17	47.37	---	74.00	54.00	-6.63	Peak
2376.00	46.68	---	2.25	48.93	---	74.00	54.00	-5.07	Peak
2462.00	89.82	---	2.37	92.20	---	---	---	---	Carrier
4800.00	42.42	---	7.07	49.50	---	74.00	54.00	-4.50	Peak
5572.50	41.23	---	8.50	49.73	---	74.00	54.00	-4.27	Peak
7020.00	44.39	32.12	10.29	54.68	42.41	74.00	54.00	-11.59	AVG

Remark:

1. Measuring frequencies from 1 GHz to the 10th harmonic of highest fundamental frequency.
2. Average test would be performed if the peak result were greater than the average limit.
3. Data of measurement within this frequency range shown " --- " in the table above means the reading of emissions are attenuated more than 20dB below the permissible limits or the field strength is too small to be measured.
4. Measurements above show only up to 6 maximum emissions noted, or would be lesser, with " N/A " remark, if no specific emissions from the EUT are recorded (ie: margin>20dB from the applicable limit) and considered that's already beyond the background noise floor.
5. In any 100 kHz bandwidth outside the frequency band in which the spread spectrum or digitally modulated intentional radiator is operating, the radio frequency power that is produced by the intentional radiator shall be at least 20 dB below that in the 100 kHz bandwidth within the band that contains the highest level of the desired power, based on either an RF conducted or a radiated measurement, provided the transmitter demonstrates compliance with the peak conducted power limits. If the transmitter complies with the conducted power limits based on the use of RMS averaging over a time interval, as permitted under paragraph (b)(3) of this section, the attenuation required under this paragraph shall be 30 dB instead of 20 dB.
6. Result = Reading + Correction Factor
Margin = Result - Limit
Remark Peak = Result(PK) - Limit(AV)
Remark AVG = Result(AV) - Limit(AV)



Restricted Band Edges

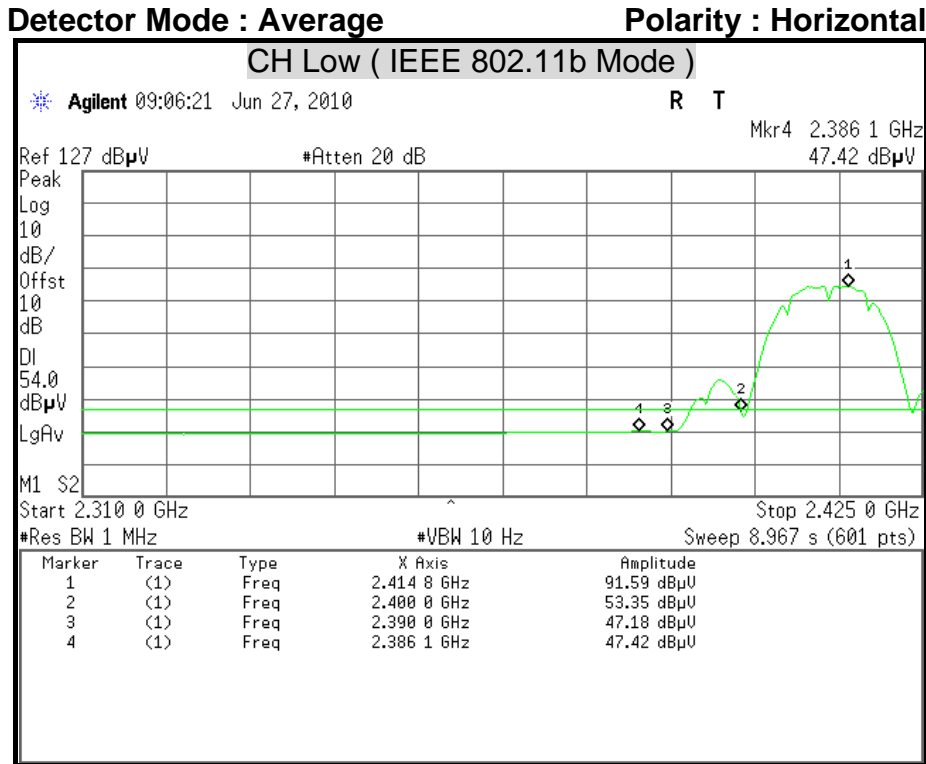
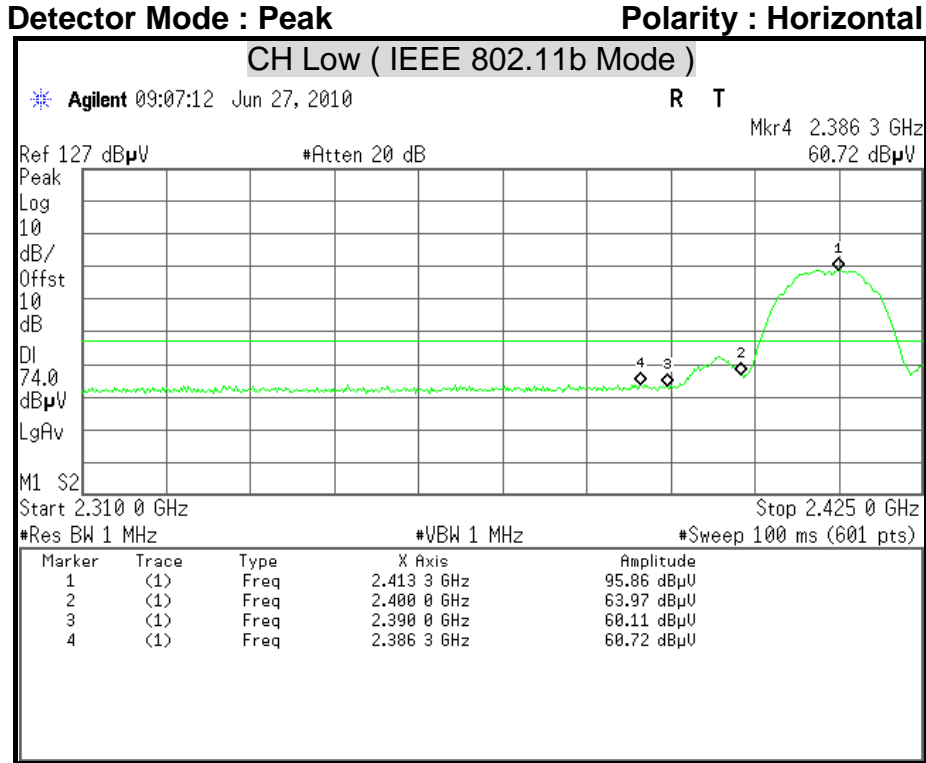

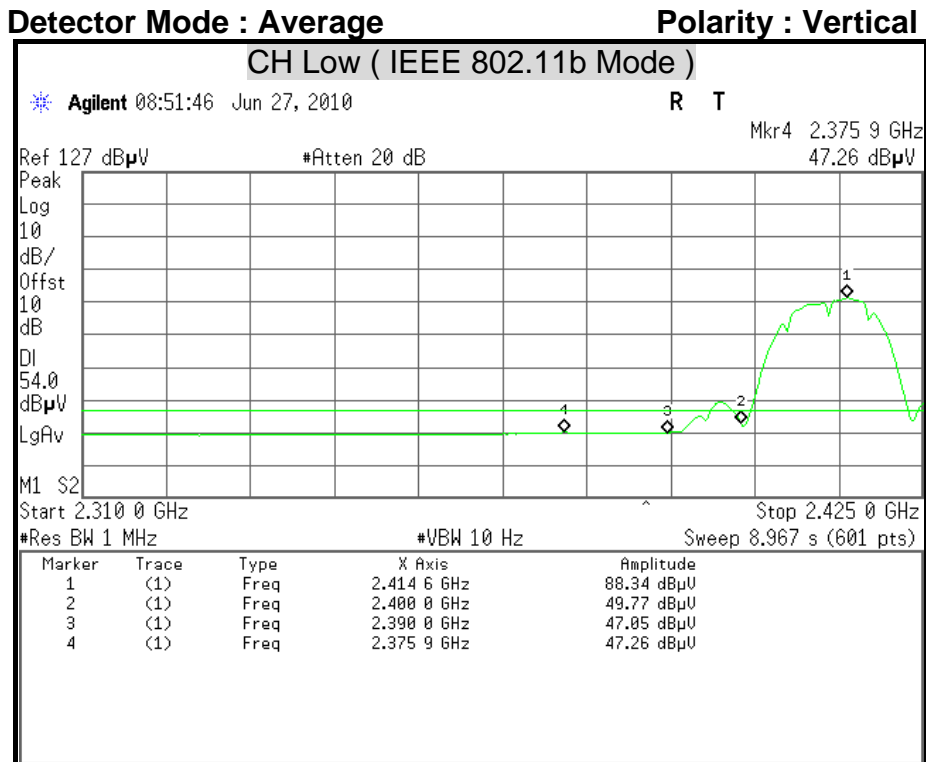
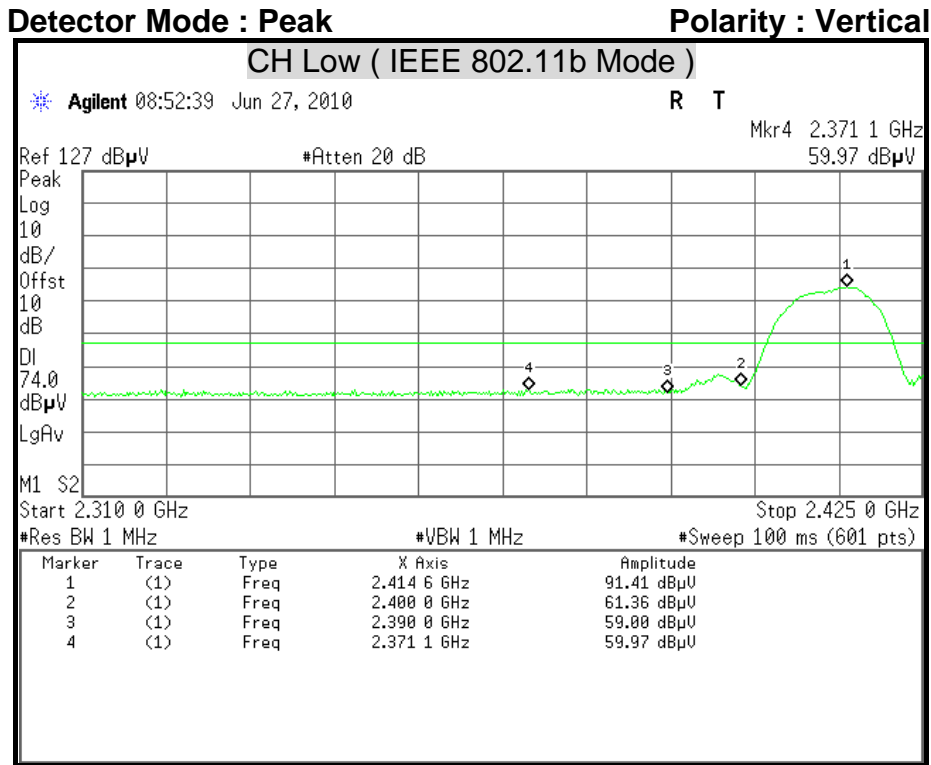



Detector Mode : Peak

Polarity : Horizontal

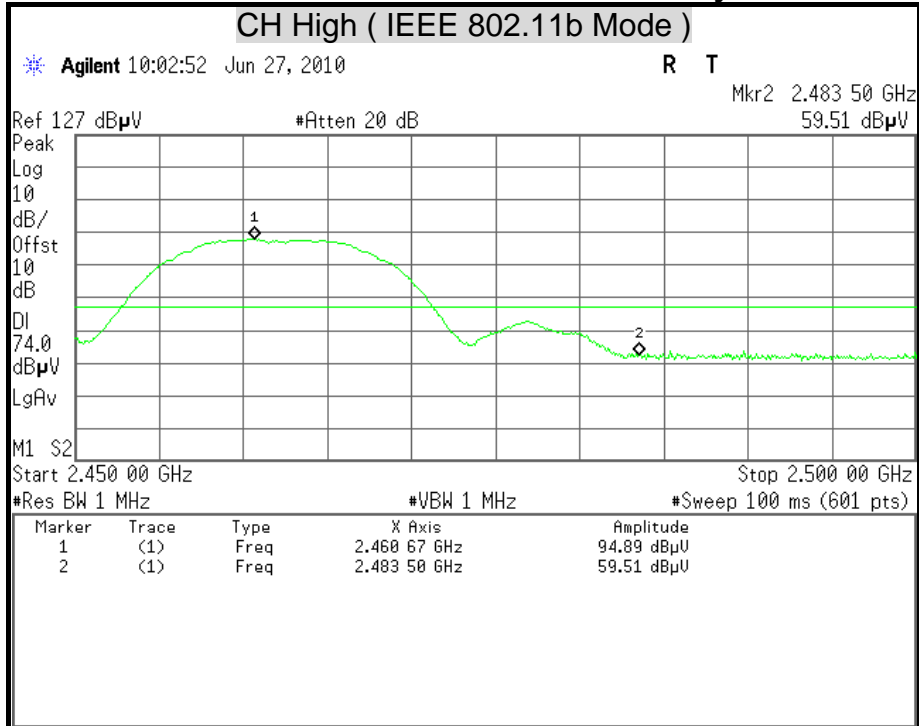

Detector Mode : Average

Polarity : Horizontal

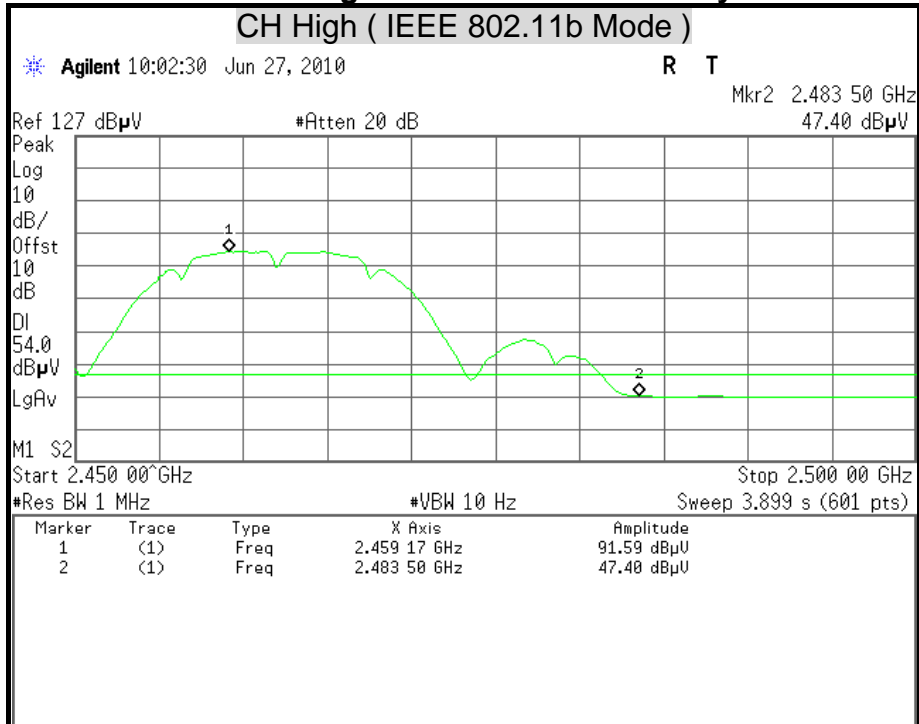

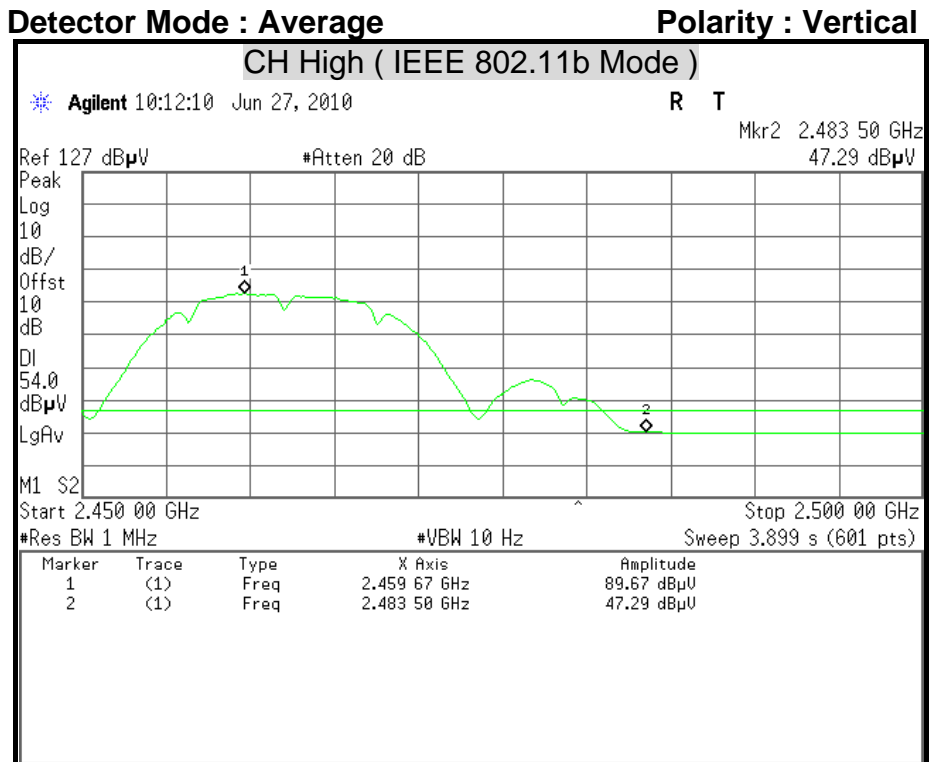
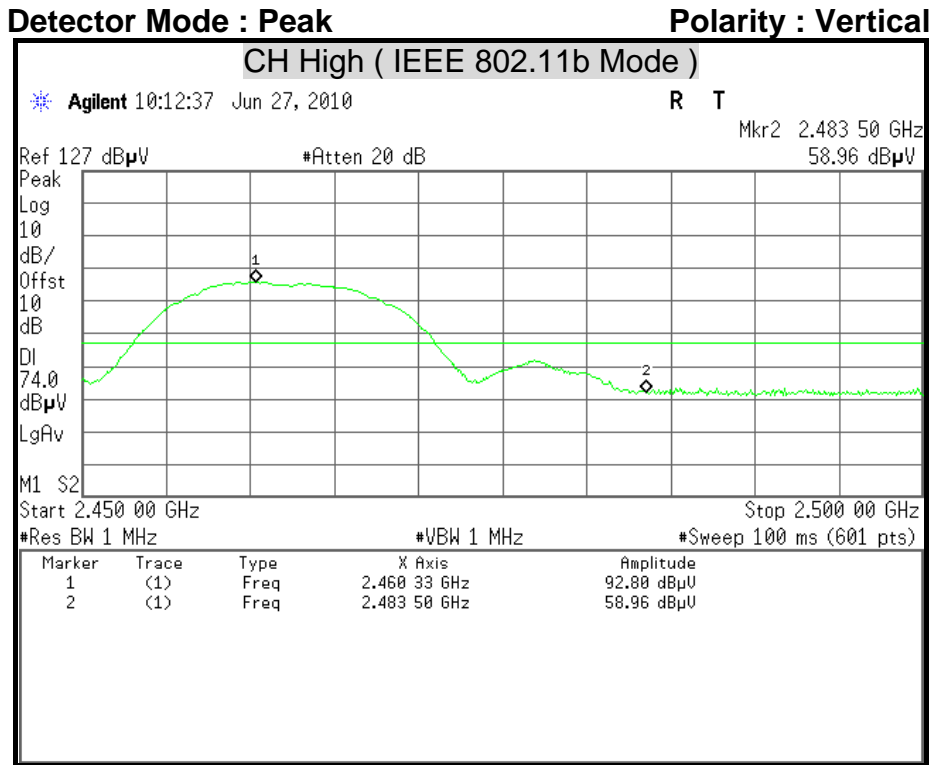



Detector Mode : Peak Polarity : Horizontal

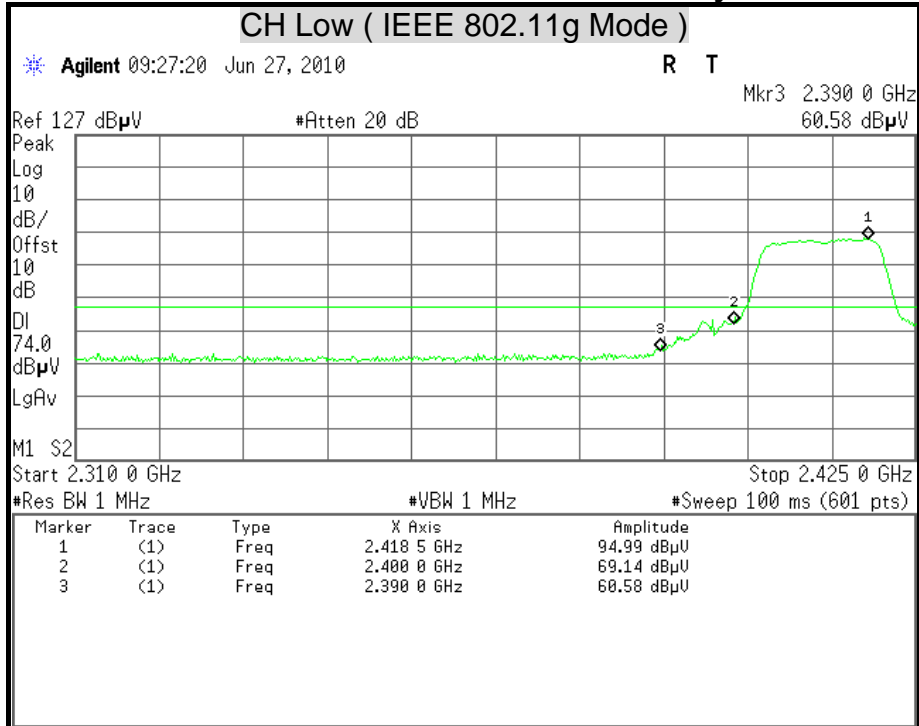

Detector Mode : Average Polarity : Horizontal

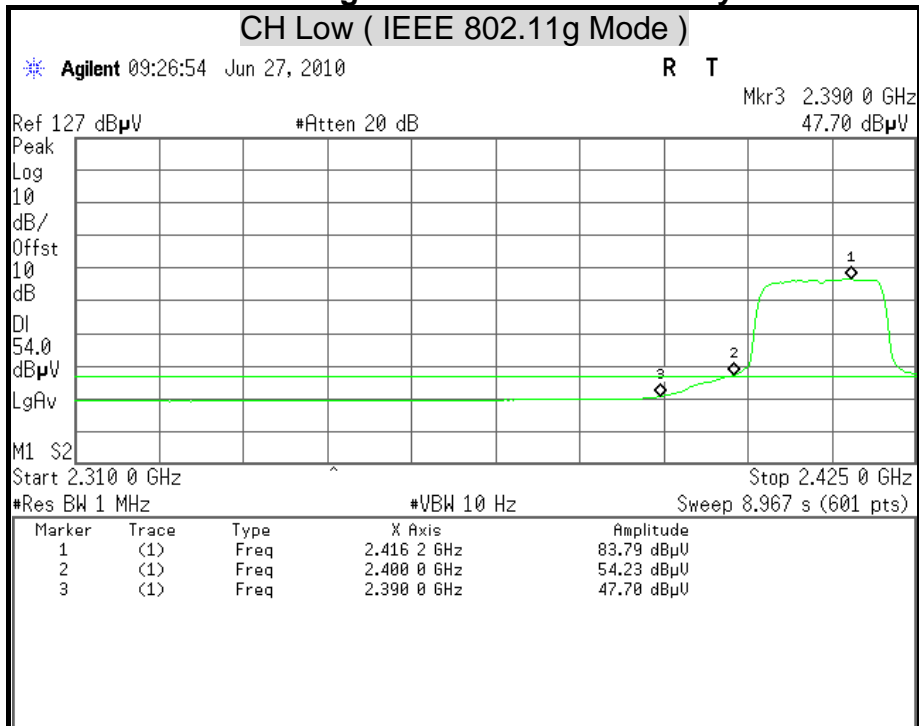

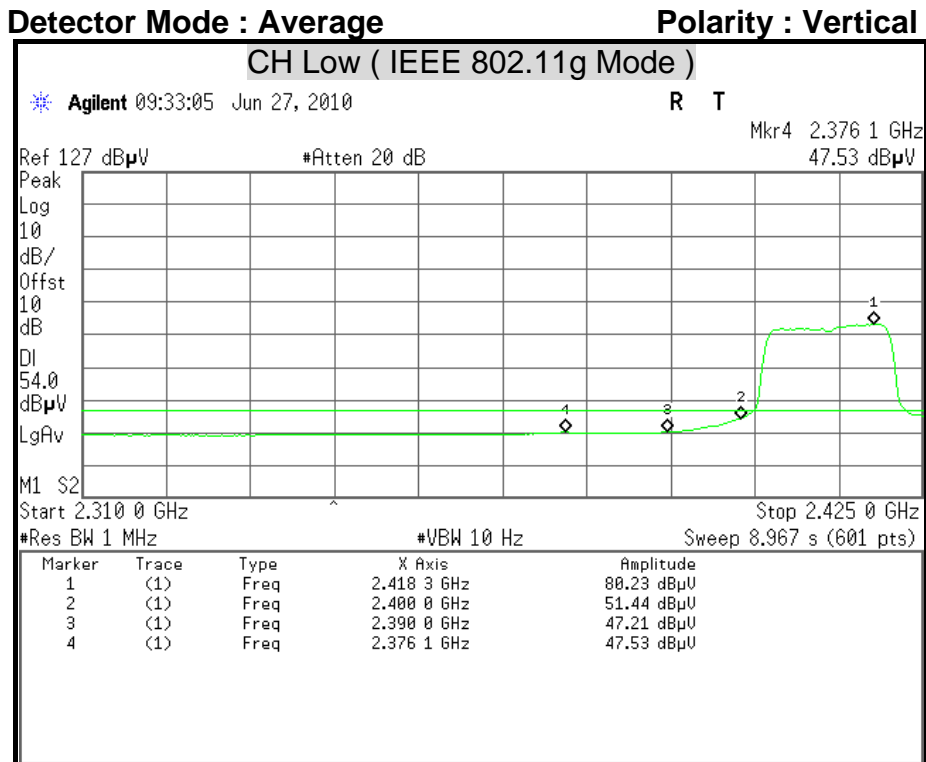
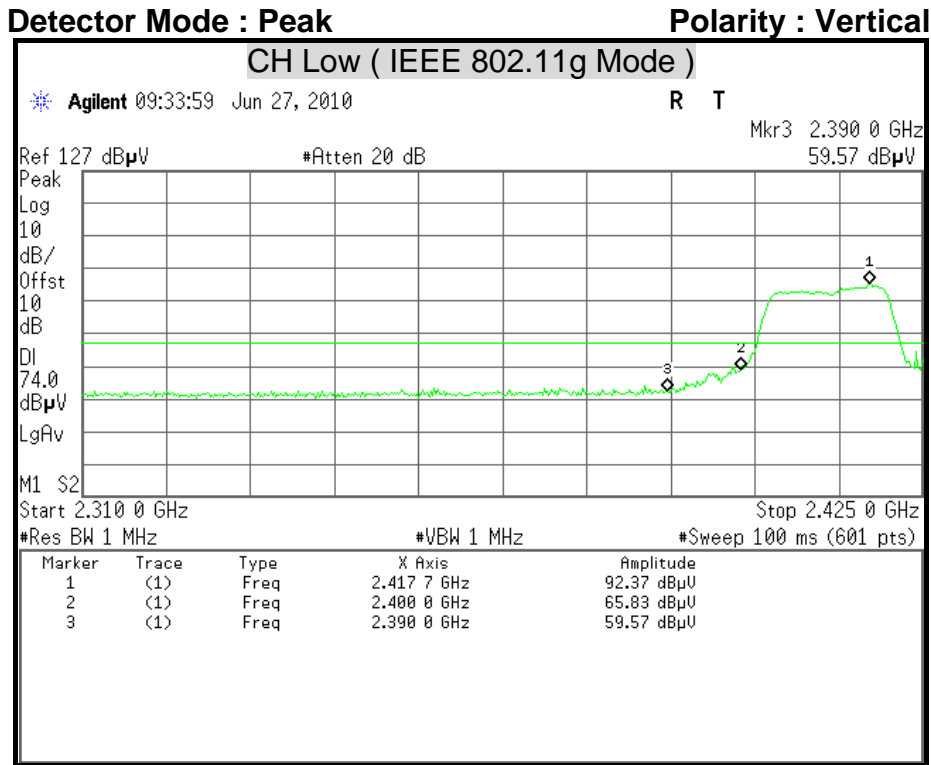



Detector Mode : Peak

Polarity : Horizontal

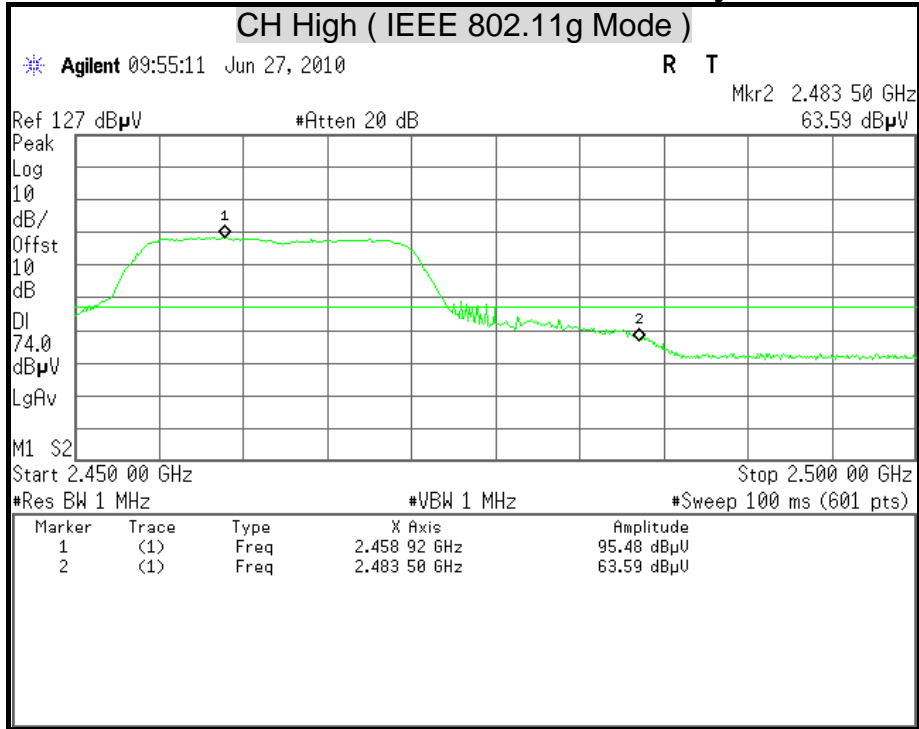

Detector Mode : Average

Polarity : Horizontal

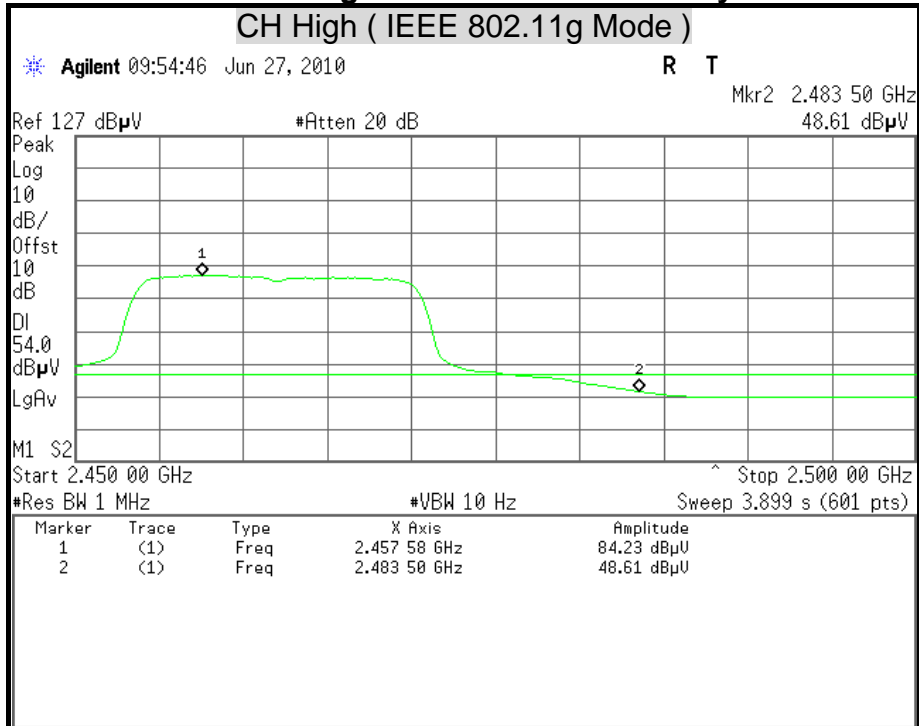



Detector Mode : Peak Polarity : Vertical

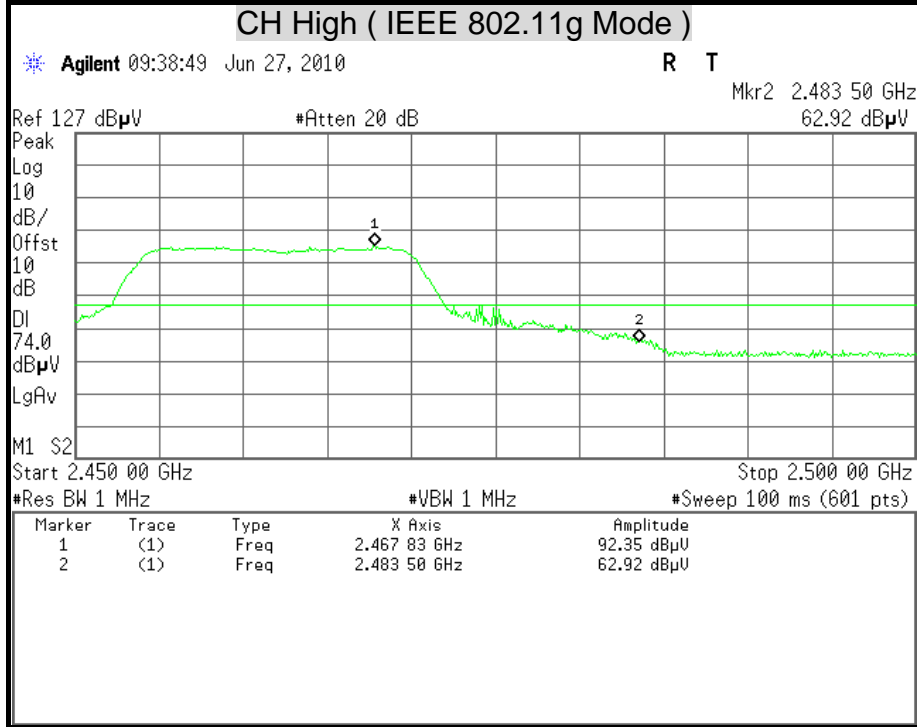

Detector Mode : Average Polarity : Vertical

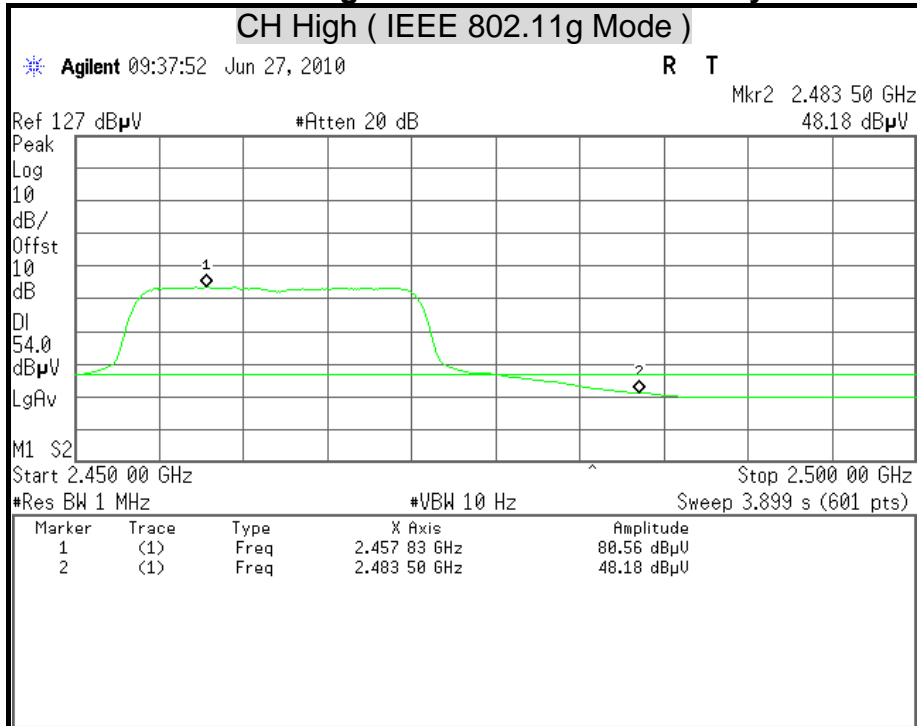



7.7 CONDUCTED EMISSION

LIMITS

§ 15.207 (a) Except as shown in paragraph (b) and (c) this section, for an intentional radiator that is designed to be connected to the public utility (AC) power line, the radio frequency voltage that is conducted back onto the AC power line on any frequency or frequencies within the band 150 kHz to 30 MHz shall not exceed the limits in the following table, as measured using a 50 μH/50 ohms line impedance stabilization network (LISN). Compliance with the provisions of this paragraph shall be based on the measurement of the radio frequency voltage between each power line and ground at the power terminal. The lower limit applies at the boundary between the frequency ranges.

Frequency Range (MHz)	Conducted Limit (dBμv)	
	Quasi-peak	Average
0.15 - 0.50	66 to 56	56 to 46
0.50 - 5.00	56	46
5.00 - 30.0	60	50

TEST EQUIPMENT

Name of Equipment	Manufacturer	Model	Serial Number	Calibration Due
L.I.S.N	SCHWARZBECK	NSLK 8127	8127-465	08/13/2010
L.I.S.N	SCHWARZBECK	NSLK 8127	8127-473	03/22/2011
EMI Test Receiver	ROHDE & SCHWARZ	ESHS 30	838550/003	01/28/2011
Pulse Limit	ROHDE & SCHWARZ	ESH3-Z2	100117	09/17/2010
N Type Coaxial Cable	BELDEN	8268 M17/164	003	07/09/2010

Remark: Each piece of equipment is scheduled for calibration once a year.

TEST SETUP

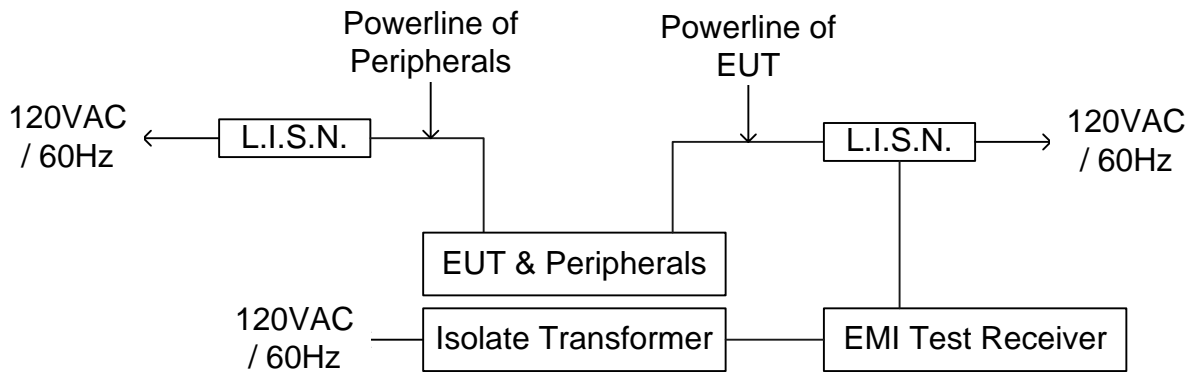
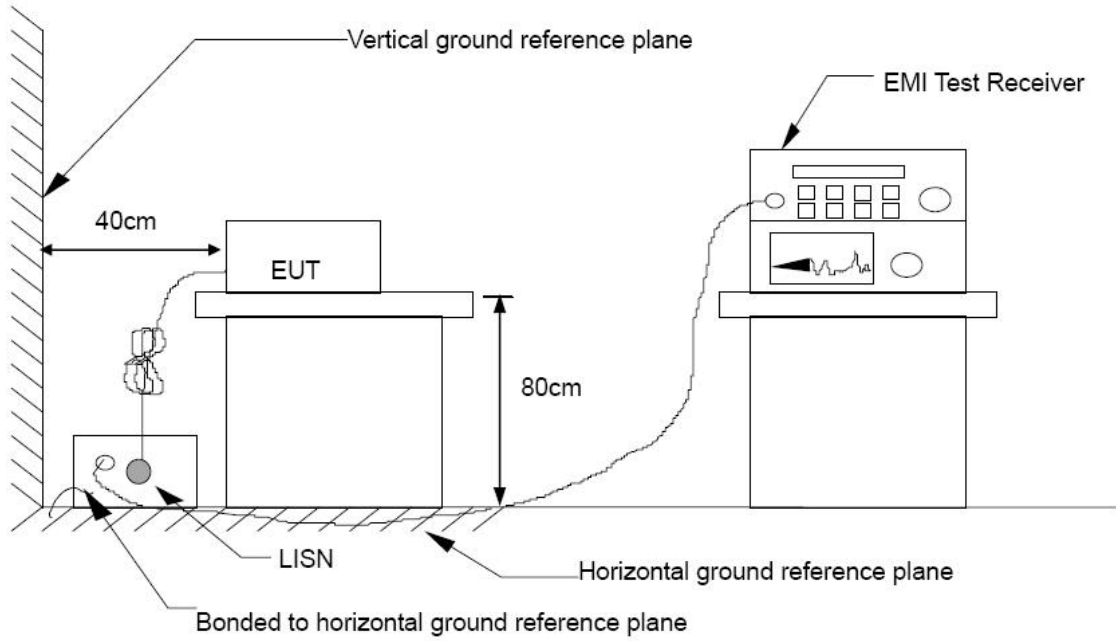



TEST PROCEDURE

The basic test procedure was in accordance with ANSI C63.4:2003.

The test procedure is performed in a 4m x 3m x 2.4m (LxWxH) shielded room.

The EUT along with its peripherals were placed on a 1.0m (W) x 1.5m (L) and 0.8m in height wooden table and the EUT was adjusted to maintain a 0.4 meter space from a vertical reference plane.

The EUT was connected to power mains through a line impedance stabilization network (LISN) which provides 50 ohm coupling impedance for measuring instrument and the chassis ground was bounded to the horizontal ground plane of shielded room. All peripherals were connected to the second LISN and the chassis ground also bounded to the horizontal ground plane of shielded room.

The EUT was located so that the distance between the boundary of the EUT and the closest surface of the LISN is 0.8 m. Where a mains flexible cord was provided by the manufacturer shall be 1 m long, or if in excess of 1 m, the excess cable was folded back and forth as far as possible so as to form a bundle not exceeding 0.4 m in length.



TEST RESULTS

Product Name	Wireless IP CAM	Test By	Joe Peng
Model	F5115	Test Date	2010/06/28
Test Mode	Normal operating (worst-case)	TEMP & Humidity	22.1°C, 59%

LINE

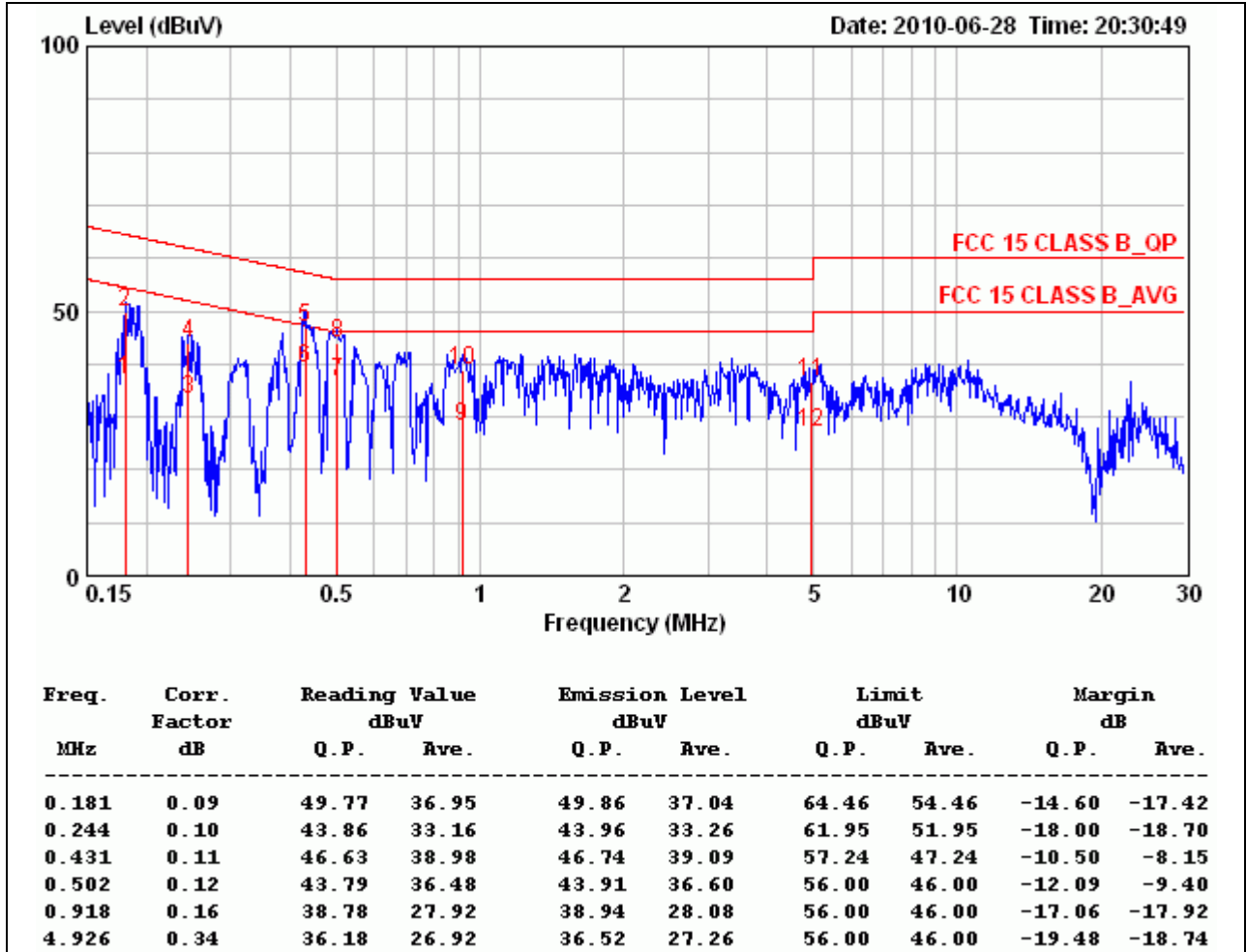

Remark:

1. Correction Factor = Insertion loss + cable loss
2. Margin value = Emission level – Limit value



Product Name	Wireless IP CAM	Test By	Joe Peng
Model	F5115	Test Date	2010/06/28
Test Mode	Normal operating (worst-case)	TEMP & Humidity	22.1°C, 59%

NEUTRAL

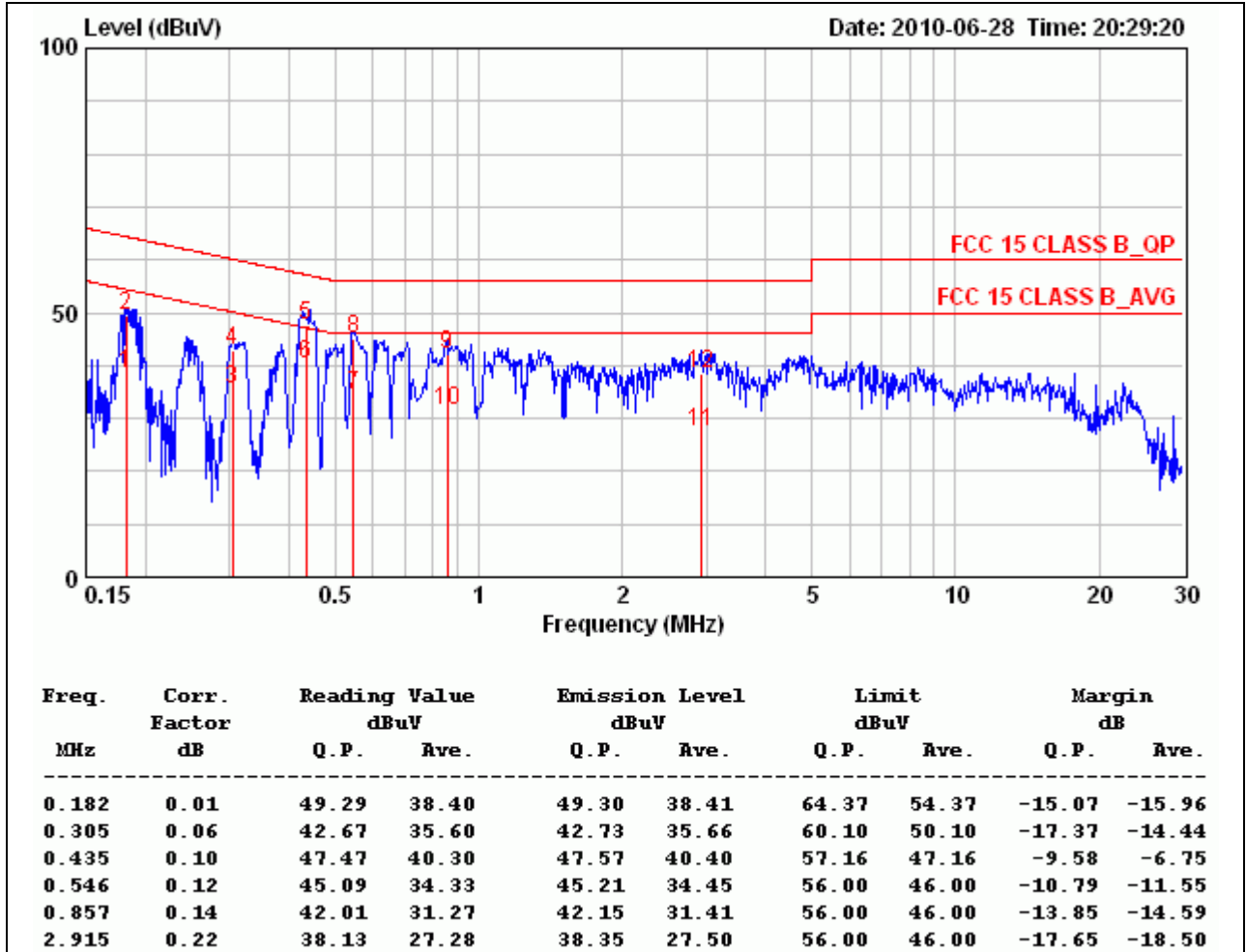

Remark:

1. Correction Factor = Insertion loss + cable loss
2. Margin value = Emission level – Limit value



APPENDIX I MAXIMUM PERMISSIBLE EXPOSURE

According to FCC 1.1310 : The criteria listed in the following table shall be used to evaluate the environment impact of human exposure to radio frequency (RF) radiation as specified in 1.1307(b) LIMITS FOR MAXIMUM PERMISSIBLE EXPOSURE (MPE)

Frequency Range (MHz)	Electric Field Strength (V/m)	Magnetic Field Strength (A/m)	Power Density (mW/cm ²)	Average Time
(A) Limits for Occupational / Control Exposures				
300-1,500	--	--	F/300	6
1,500-100,000	--	--	5	6
(B) Limits for General Population / Uncontrol Exposures				
300-1,500	--	--	F/1500	6
1,500-100,000	--	--	1	30

CALCULATIONS

Given $E = \frac{\sqrt{30 \times P \times G}}{d}$ & $S = \frac{E^2}{3770}$

Where *E* = Field strength in Volts / meter

P = Power in Watts

G = Numeric antenna gain

d = Distance in meters

S = Power density in milliwatts / square centimeter

Combining equations and re-arranging the terms to express the distance as a function of the remaining variables yields:

$$S = \frac{30 \times P \times G}{3770d^2}$$

Changing to units of mW and cm, using:

$$P (mW) = P (W) / 1000 \text{ and}$$

$$d (cm) = d(m) / 100$$

Yields

$$S = \frac{30 \times (P/1000) \times G}{3770 \times (d/100)^2} = 0.0796 \times \frac{P \times G}{d^2}$$

Where *d* = Distance in cm

P = Power in mW

G = Numeric antenna gain

S = Power density in mW / cm²



LIMIT

Power Density Limit, S=1.0mW/cm²

TEST RESULTS

Mode	Antenna Gain (dBi)	Minimum separation distance (cm)	Output Power (dBm)	Numeric antenna gain (mW)	Power Density Limit (mW/cm ²)	Power Density at 20cm (mW/cm ²)
IEEE 802.11b	2	20.0	21.75	1.58	1.00	0.047176
IEEE 802.11g	2	20.0	19.68	1.58	1.00	0.029290

Remark: For mobile or fixed location transmitters, the maximum power density is 1.0 mW/cm² even if the calculation indicates that the power density would be larger.