

FCC 47 CFR PART 15 SUBPART E

Applicant : Champtek Incorporated
Product Type : Price Checker
Trade Name : SCANTECH ID, CHAMPTEK
Model Number : SG15 Colour, Shuttle C
Applicable Standard : FCC 47 CFR PART 15 SUBPART E
ANSI C63.10:2013
Receive Date : Sep. 10, 2016
Test Period : Sep. 15, ~ Nov. 22, 2016
Issue Date : Jan. 04, 2017

Issue by

A Test Lab Techno Corp.
No. 140-1, Changan Street, Bade District,
Taoyuan City 33465, Taiwan (R.O.C)
Tel : +86-3-2710188 / Fax : +86-3-2710190



Taiwan Accreditation Foundation accreditation number: 1330

Note: This report shall not be reproduced except in full, without the written approval of A Test Lab Techno Corp. This document may be altered or revised by A Test Lab Techno Corp. personnel only, and shall be noted in the revision section of the document. The client should not use it to claim product endorsement by TAF, or any government agencies. The test results in the report only apply to the tested sample.



Revision History

Rev.	Issue Date	Revisions	Revised By
00	Dec. 02, 2016	Initial Issue	Joyce Liao
01	Jan. 04, 2017	Revised report information.	Joyce Liao



Verification of Compliance

Issued Date: Jan. 04, 2017

Applicant : Champtek Incorporated
Product Type : Price Checker
Trade Name : SCANTECH ID, CHAMPTEK
Model Number : SG15 Colour, Shuttle C
FCC ID : WOI-SG15COLOUR
EUT Rated Voltage : DC 5V, 2A
Test Voltage : 120 Vac / 60 Hz
Applicable Standard : FCC 47 CFR PART 15 SUBPART E
ANSI C63.10:2013
Test Result : Complied
Performing Lab. : A Test Lab Techno Corp.
No. 140-1, Changan Street, Bade District,
Taoyuan City 33465, Taiwan (R.O.C)
Tel : +86-3-2710188 / Fax : +86-3-2710190
Taiwan Accreditation Foundation accreditation number: 1330
<http://www.atl-lab.com.tw/e-index.htm>

A Test Lab Techno Corp. tested the above equipment in accordance with the requirements set forth in the above standards. All indications of Pass/Fail in this report are opinions expressed by A Test Lab Techno Corp. based on interpretations and/or observations of test results. Measurement Uncertainties were not taken into account and are published for informational purposes only. The test results show that the equipment tested is capable of demonstrating compliance with the requirements as documented in this report.

Approved By : Fly Lu Reviewed By : Eric Ou Yang
(Manager) (Fly Lu) (Testing Engineer) (Eric Ou Yang)



TABLE OF CONTENTS

1	General Information	5
1.1.	Summary of Test Result.....	5
1.2.	Measurement Uncertainty.....	5
2	EUT Description	6
3	Test Methodology.....	7
3.1.	Mode of Operation.....	7
3.2.	EUT Exercise Software.....	11
3.3.	Configuration of Test System Details	12
3.4.	Test Site Environment.....	13
4	Test Results.....	14
4.1.	AC Power Conducted Emission Measurement	14
4.2.	Transmitter Radiated Emissions Measurement.....	18
4.3.	Maximum Conducted Output Power and Transmit power control Measurement	50
4.4.	26dB RF Bandwidth Measurement	52
4.5.	Peak Power Spectral Density Measurement.....	58
4.6.	Frequency Stability Measurement.....	64
4.7.	Test Procedure	64
4.8.	Antenna Requirement.....	66



1 General Information

1.1. Summary of Test Result

Standard	Item	Result	Remark
15.407(b)(6) 15.207	AC Power Conducted Emission	PASS	---
15.407(b) 15.205 / 15.209	Transmitter Radiated Emissions	PASS	---
15.407(a)	Maximum Conducted Output Power	PASS	---
15.407(a)	26dB RF Bandwidth	Reference	---
15.407(a)	Peak Power Spectral Density	PASS	---
15.407(g)	Frequency Stability	PASS	---
15.407(a) 15.203	Antenna Requirement	PASS	---

The test results of this report relate only to the tested sample(s) identified in this report. Manufacturer or whom it may concern should recognize the pass or fail of the test result.

1.2. Measurement Uncertainty

Test Item	Frequency Range	Uncertainty (dB)
Conducted Emission	9kHz ~ 150KHz	2.7
	150kHz ~ 30MHz	2.7
Radiated Emission	9kHz ~ 30MHz	1.7
	30MHz ~ 1000MHz	5.7
	1000MHz ~ 18000MHz	5.5
	18000MHz ~ 26500MHz	4.8
	26500MHz ~ 40000MHz	4.8
Conducted Output Power		+0.27 dB / -0.28 dB
RF Bandwidth		4.96%
Power Spectral Density		+0.71 dB / -0.77 dB
Frequency Stability		+ 2.212 x 10 ⁻⁷ % / - 2.170 x 10 ⁻⁷
Duty Cycle		1.06%
Time Occupancy		1.40%



2 EUT Description

Applicant	Champtek Incorporated 5/F, No.2, Alley 2, Shih-Wei Lane, Chung Cheng Rd., Hsin Tien City, Taiwan			
Manufacturer	Champtek Incorporated 5/F, No.2, Alley 2, Shih-Wei Lane, Chung Cheng Rd., Hsin Tien City, Taiwan			
Product Type	Price Checker			
Trade Name	SCANTECH ID, CHAMPTEK			
Model Number	SG15 Colour, Shuttle C			
Trade Name and Model Number Different Description	Those trade name and model numbers differ from each other in selling region.			
FCC ID	WOI-SG15COLOUR			
Operate Frequency	Frequency Band		Frequency Range (MHz)	Number of Channels
	IEEE 802.11a	U-NII Band II-A	5260 – 5320	4
	IEEE 802.11n 5GHz 20 MHz	U-NII Band II-A	5260 – 5320	4
	IEEE 802.11n 5GHz 40 MHz	U-NII Band II-A	5270 – 5310	2
	IEEE 802.11ac 80 MHz	U-NII Band II-A	5290	1
Modulation Type	OFDM			
Equipment Type	Client devices			
Antenna information	Model	Type	Max. Gain (dBi)	
	F39-FL-113-100IPEX	PCB Antenna	2.5	
Antenna Delivery	1TX + 1RX			
Frequency Stability Specification	± 20 ppm			
Component List				
Power adapter	Trade Name:	APD	Model Number: WB-10E05R	
	I/P: 100-240VAC, 50-60Hz, 0.4A			
	O/P: 5VDC, 2A			
Cable out: Non-Shielded, 2.4m, Non-Detachable at Power Adapter				

Frequency Band		RF Output Power (W)
IEEE 802.11a	U-NII Band II-A	0.028
IEEE 802.11n 5GHz 20 MHz	U-NII Band II-A	0.027
IEEE 802.11n 5GHz 40 MHz	U-NII Band II-A	0.024
IEEE 802.11ac 80 MHz	U-NII Band II-A	0.021



3 Test Methodology

3.1. Mode of Operation

Decision of Test ATL has verified the construction and function in typical operation. All the test modes were carried out with the EUT in normal operation, which was shown in this test report and defined as:

Test Mode
Mode 1: Continuous TX mode
Mode 2: IEEE 802.11a Link Mode
Mode 3: IEEE 802.11n 5GHz 20MHz mode
Mode 4: IEEE 802.11n 5GHz 40MHz mode
Mode 5: IEEE 802.11ac 80MHz Link Mode

Software used to control the EUT for staying in continuous transmitting mode was programmed.

After verification, all tests were carried out with the worst case test modes as shown below except radiated spurious emission below 1GHz and power line conducted emissions below 30MHz, which worst case was in normal link mode only.

Equipment Type	
Outdoor access point	---
Indoor access point	---
Fixed point-to-point access points	---
Client devices	V

Test Mode	Band	Data Rate	Test Channel
Mode 2	U-NII Band II-A	6	52, 56, 64
Mode 3	U-NII Band II-A	6.5	52, 56, 64
Mode 4	U-NII Band II-A	13.5	54, 62
Mode 5	U-NII Band II-A	29.3	58

Duty cycle

Test Mode	Frequency (MHz)	on time (ms)	on+off time (ms)	Duty cycle	Duty Factor (dB)	1/T Minimum VBW (kHz)
Mode 2	5260.0	1.000	1.000	1.000	0.000	0.010
Mode 3	5260.0	1.000	1.000	1.000	0.000	0.010
Mode 4	5270.0	1.000	1.000	1.000	0.000	0.010
Mode 5	5290.0	1.000	1.000	1.000	0.000	0.010

Duty Cycle Graphs

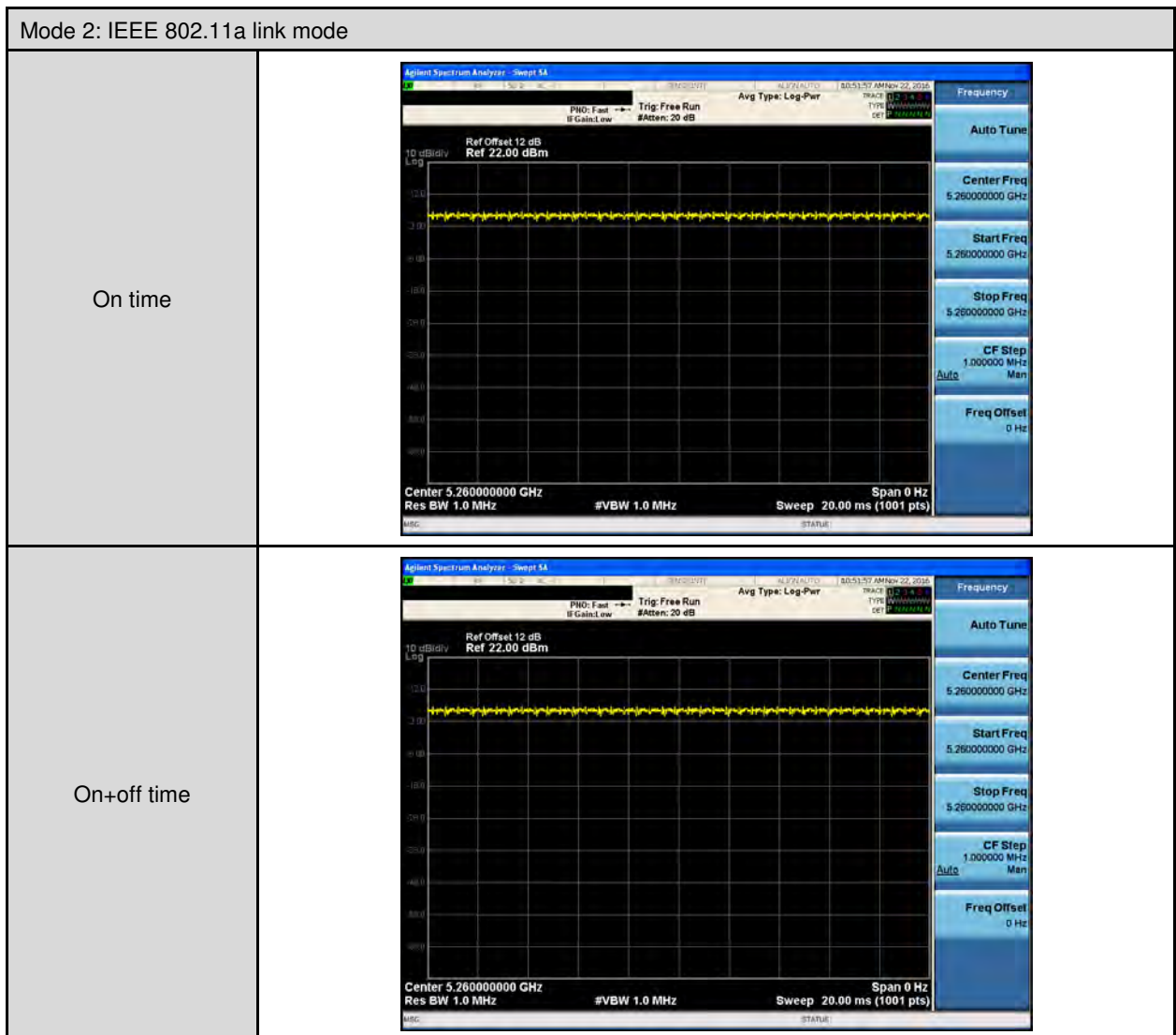



Mode 3: IEEE 802.11n 5GHz 20MHz mode	
On time	
On+off time	

Mode 4: IEEE 802.11n 5GHz 40MHz mode	
<p>On time</p>	
<p>On+off time</p>	

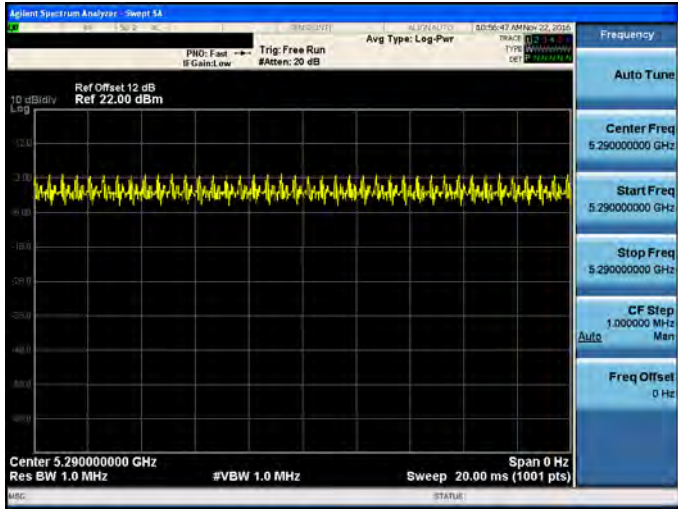
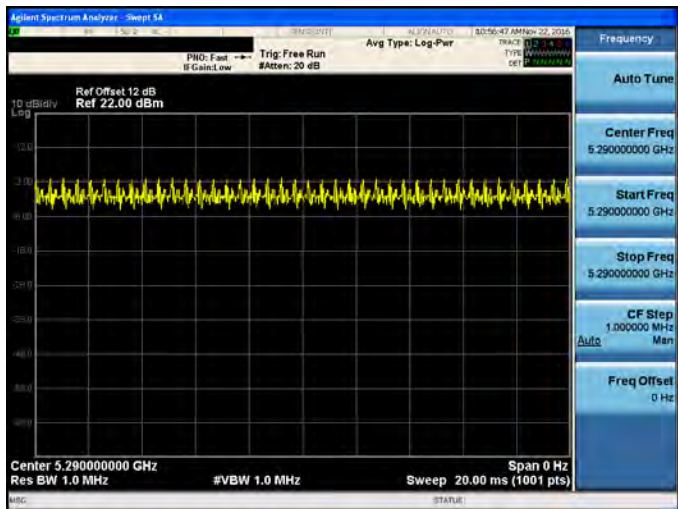
Mode 5: IEEE 802.11ac 80MHz Link Mode	
On time	
On+off time	

3.2. EUT Exercise Software

The EUT is operated in the engineering mode to fix the TX frequency for the purposes of measurement. According to its specifications, the EUT must comply with the requirements of Section 15.407 under the FCC Rules Part 15 Subpart E.

1.	Setup the EUT shown on 3.3.
2.	Turn on the power of all equipment.
3.	EUT run test program.

Measurement Software	
1	EZ-EMC Ver. ATL-03A1-1
2	EZ-EMC Ver ATL-ITC-3A1-1

3.3. Configuration of Test System Details

Conducted Emission

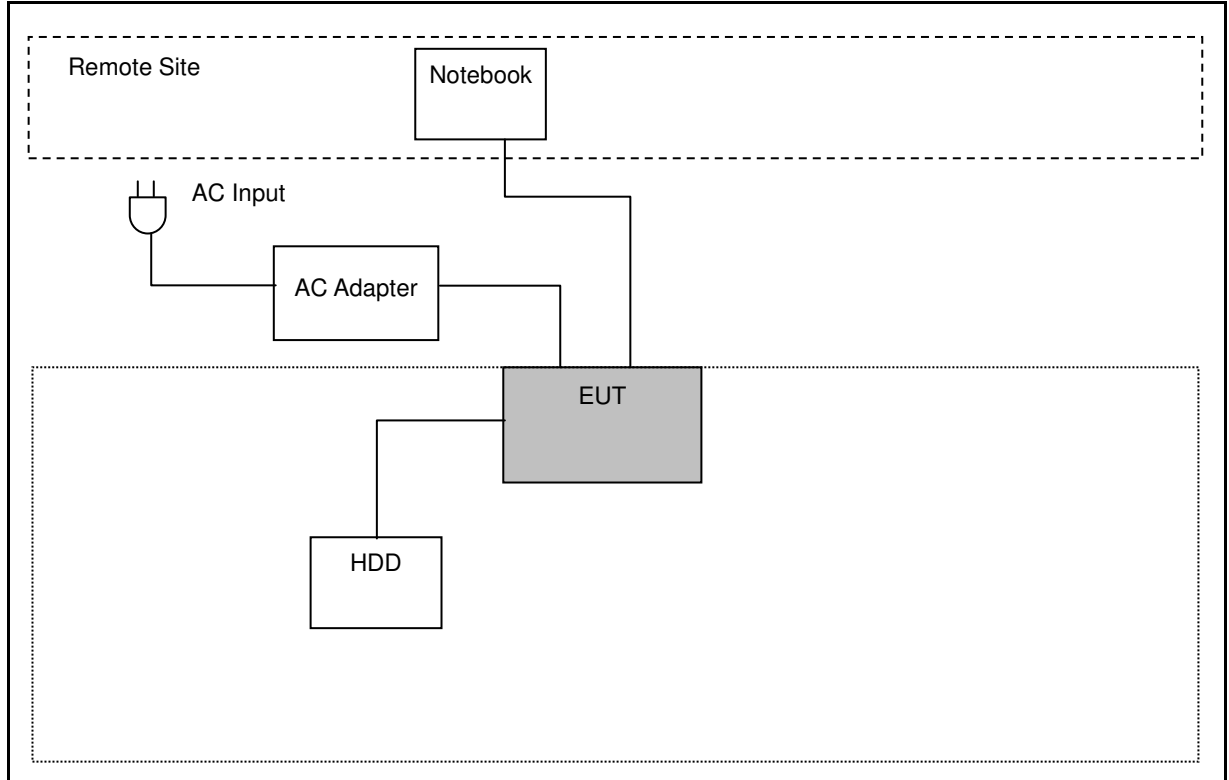

Radiated Emission

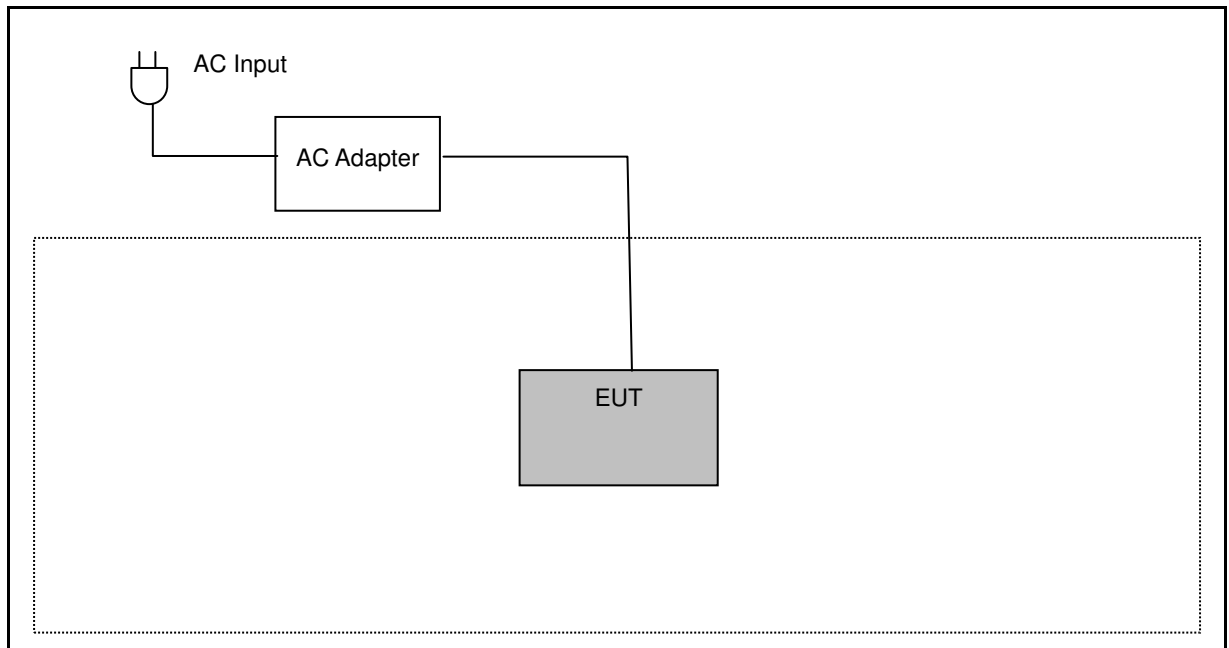



3.4. Test Site Environment

Items	Required (IEC 60068-1)	Actual
Temperature (°C)	15-35	26
Humidity (%RH)	25-75	60
Barometric pressure (mbar)	860-1060	950

4 Test Results

4.1. AC Power Conducted Emission Measurement

■ Limit

Frequency (MHz)	Quasi-peak	Average
0.15 - 0.5	66 to 56	56 to 46
0.50 - 5.0	56	46
5.0 - 30.0	60	50

■ Test Instruments

Equipment	Manufacturer	Model Number	Serial Number	Cal. Date	Cal. Period
Test Receiver	R&S	ESCI	100367	05/31/2016	1 year
LISN	R&S	ENV216	101040	03/15/2016	1 year
LISN	R&S	ENV216	101041	03/07/2016	1 year
RF Cable	Woken	00100D1380194M	TE-02-02	05/31/2016	1 year
Test Site	ATL	TE02	TE02	N.C.R.	-----

Note: N.C.R. = No Calibration Request.

■ Test Setup

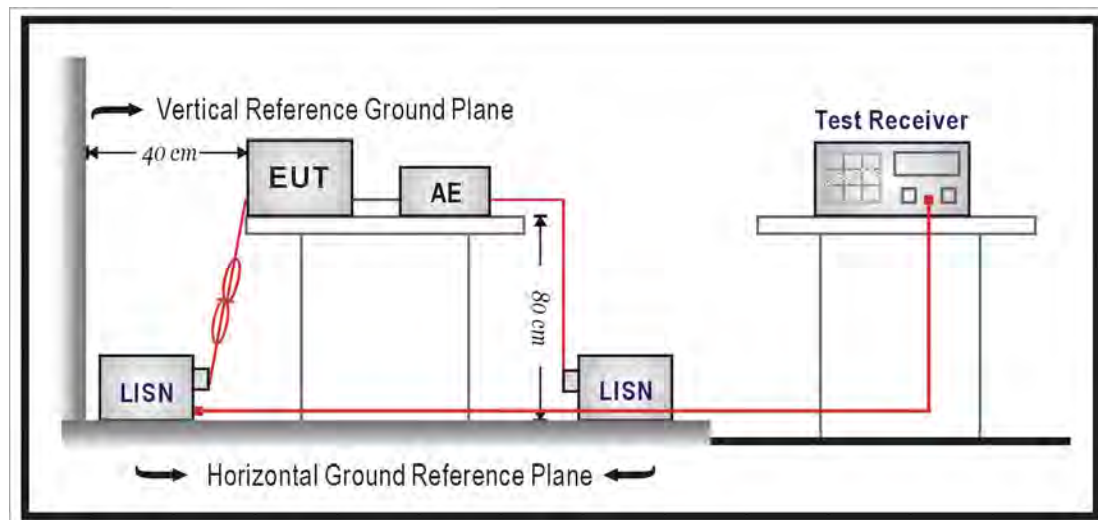

■ Test Procedure

The EUT and simulators are connected to the main power through a line impedance stabilization network (L.I.S.N.). This provides a $50\ \Omega // 50\ \mu\text{H}$ coupling impedance for the measuring equipment. The peripheral devices are also connected to the main power through a LISN that provides a $50\ \Omega // 50\ \mu\text{H}$ coupling impedance with 50ohm termination.

Tabletop device shall be placed on a non-conducting platform, of nominal size 1 m by 1.5 m, raised 80 cm above the reference ground plane. The wall of screened room shall be located 40cm to the rear of the EUT. Other surfaces of tabletop or floor standing EUT shall be at least 80cm from any other ground conducting surface including one or more LISNs. For floor-standing device shall be placed under the EUT with a 12mm insulating material.

Conducted emissions were investigated over the frequency range from 0.15 MHz to 30 MHz using a resolution bandwidth of 9 kHz. The equipment under test (EUT) shall be meet the limits in section 4.1, as applicable, including the average limit and the quasi-peak limit when using respectively, an average detector and quasi-peak detector measured in accordance with the methods described of related standard. When all of peak value were complied with quasi-peak and average limit from 150kHz to 30MHz then quasi-peak and average measurement was unnecessary.

The AMN shall be placed 0,8 m from the boundary of the unit under test and bonded to a ground reference plane for AMNs mounted on top of the ground reference plane. This distance is between the closest points of the AMN and the EUT. All other units of the EUT and associated equipment shall be at least 0,8 m from the AMN. If the mains power cable is longer than 1m then the cable shall be folded back and forth at the centre of the lead to form a bundle no longer than 0.4m. All of interconnecting cables that hang closer than 40cm to the ground plane shall be folded back and forth in the center forming a bundle 30 cm to 40 cm long. All of EUT and AE shall be separate place more than 0.1m. All $50\ \Omega$ ports of the LISN shall be resistively terminated into $50\ \Omega$ loads when not connected to the measuring instrument.

If the reading of the measuring receiver shows fluctuations close to the limit, the reading shall be observed for at least 15 s at each measurement frequency; the higher reading shall be recorded with the exception of any brief isolated high reading which shall be ignored.



■ Test Result

Standard:	FCC Part 15E	Line:	L1
Test item:	Conducted Emission	Power:	AC 120V/60Hz
Test Mode:	Mode 1	Temp.(°C)/Hum.(%RH):	26(°C)/60%RH
		Date:	09/15/2016
Description:			

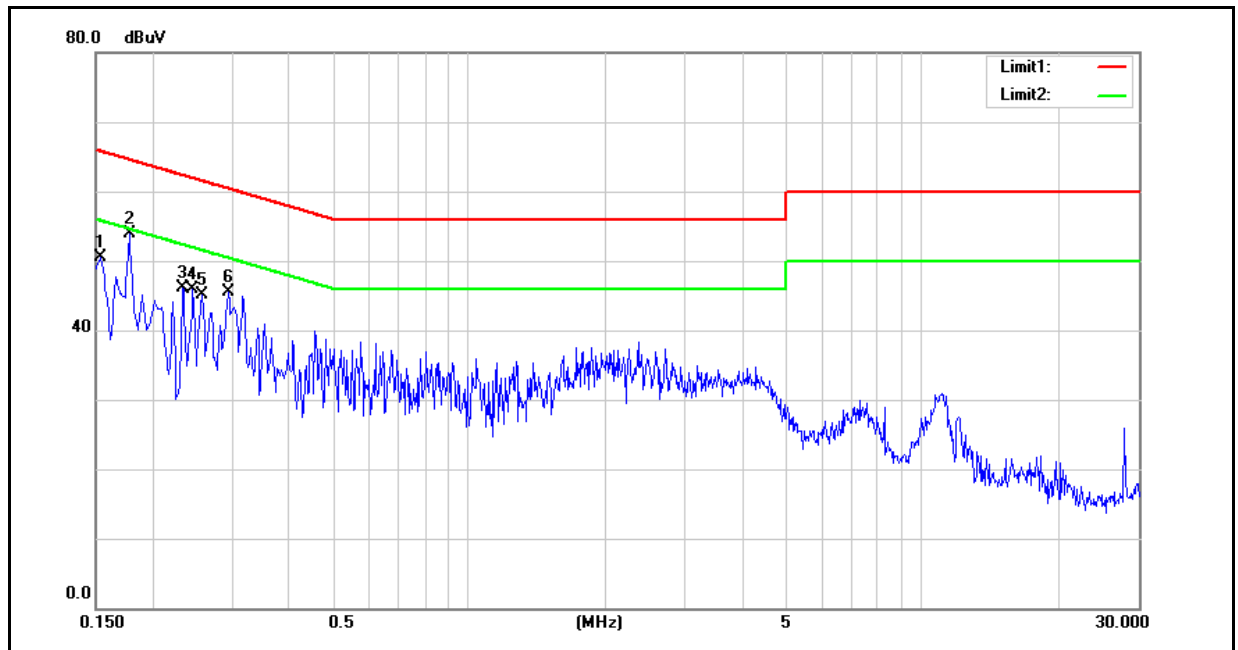

No.	Frequency (MHz)	QP reading (dBuV)	AVG reading (dBuV)	Correction factor (dB)	QP result (dBuV)	AVG result (dBuV)	QP limit (dBuV)	AVG limit (dBuV)	QP margin (dB)	AVG margin (dB)	Remark
1	0.1540	38.43	26.04	9.60	48.03	35.64	65.78	55.78	-17.75	-20.14	Pass
2	0.1780	36.30	26.13	9.59	45.89	35.72	64.58	54.58	-18.69	-18.86	Pass
3	0.2340	32.00	21.22	9.59	41.59	30.81	62.31	52.31	-20.72	-21.50	Pass
4	0.2460	31.14	15.79	9.59	40.73	25.38	61.89	51.89	-21.16	-26.51	Pass
5	0.2580	31.87	19.99	9.60	41.47	29.59	61.50	51.50	-20.03	-21.91	Pass
6	0.2940	29.56	21.28	9.60	39.16	30.88	60.41	50.41	-21.25	-19.53	Pass

Note: 1. Result = Correction factor + Reading
 2. Correction factor = Antenna Factor + Cable loss – Pre-Amplifier gain.



Standard:	FCC Part 15E	Line:	N
Test item:	Conducted Emission	Power:	AC 120V/60Hz
Test Mode:	Mode 1	Temp.(°C)/Hum.(%RH):	26(°C)/60%RH
		Date:	09/15/2016
Description:			

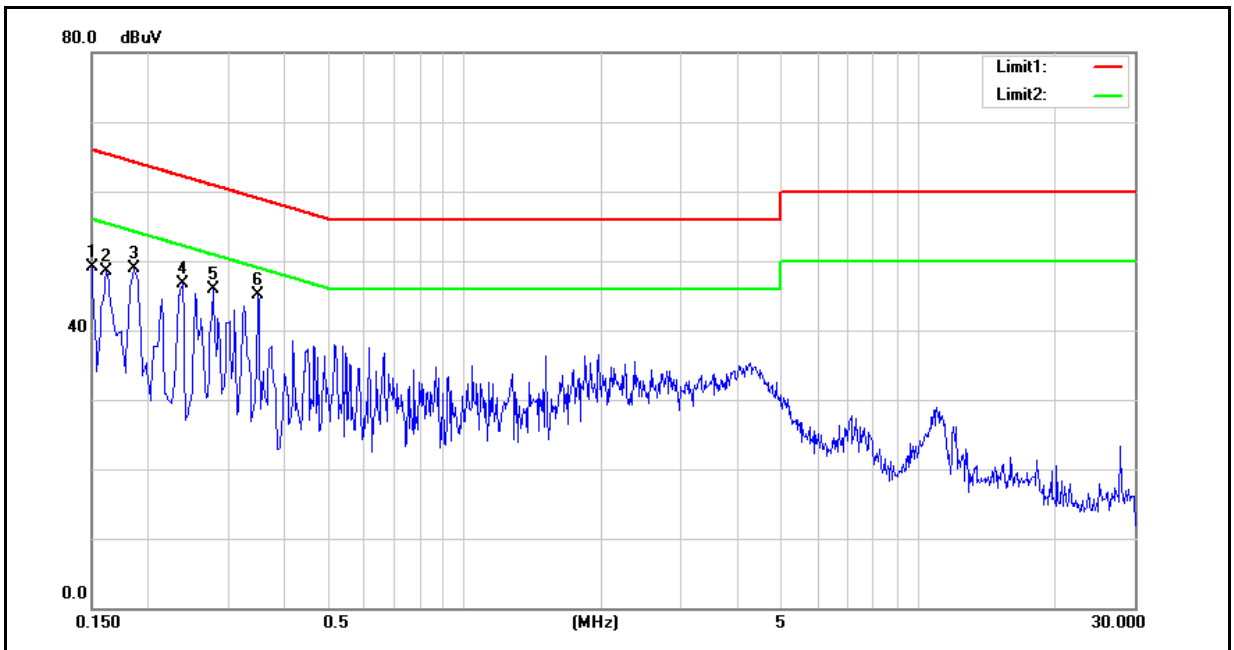

No.	Frequency (MHz)	QP reading (dBuV)	AVG reading (dBuV)	Correction factor (dB)	QP result (dBuV)	AVG result (dBuV)	QP limit (dBuV)	AVG limit (dBuV)	QP margin (dB)	AVG margin (dB)	Remark
1	0.1500	38.62	28.74	9.59	48.21	38.33	66.00	56.00	-17.79	-17.67	Pass
2	0.1620	37.49	26.45	9.59	47.08	36.04	65.36	55.36	-18.28	-19.32	Pass
3	0.1860	35.16	24.80	9.58	44.74	34.38	64.21	54.21	-19.47	-19.83	Pass
4	0.2380	31.40	16.43	9.58	40.98	26.01	62.17	52.17	-21.19	-26.16	Pass
5	0.2780	29.13	22.77	9.59	38.72	32.36	60.88	50.88	-22.16	-18.52	Pass
6	0.3500	27.40	14.70	9.59	36.99	24.29	58.96	48.96	-21.97	-24.67	Pass

Note: 1. Result = Correction factor + Reading
 2. Correction factor = Antenna Factor + Cable loss – Pre-Amplifier gain.



4.2. Transmitter Radiated Emissions Measurement

■ Limit

(1) Undesirable emission limits. Except as shown in paragraph (b)(7) of this section, the maximum emissions outside of the frequency bands of operation shall be attenuated in accordance with the following limits:

(a) For transmitters operating in the 5.15-5.25 GHz band: All emissions outside of the 5.15-5.35 GHz band shall not exceed an e.i.r.p. of -27 dBm/MHz.

(b) For transmitters operating in the 5.25-5.35 GHz band: All emissions outside of the 5.15-5.35 GHz band shall not exceed an e.i.r.p. of -27 dBm/MHz.

(c) For transmitters operating in the 5.47-5.725 GHz band: All emissions outside of the 5.47-5.725 GHz band shall not exceed an e.i.r.p. of -27 dBm/MHz.

(d) For transmitters operating in the 5.725-5.85 GHz band:

(i) All emissions shall be limited to a level of -27 dBm/MHz at 75 MHz or more above or below the band edge increasing linearly to 10 dBm/MHz at 25 MHz above or below the band edge, and from 25 MHz above or below the band edge increasing linearly to a level of 15.6 dBm/MHz at 5 MHz above or below the band edge, and from 5 MHz above or below the band edge increasing linearly to a level of 27 dBm/MHz at the band edge.

(2) Limits of Radiated Emission Measurement

Emissions radiated outside of the specified bands, shall be according to the general radiated limits in 15.209 as following:

Frequency Range (MHz)	Field Strength (microvolts/meter)	Measurement Distance (meters)
0.009 ~ 0.490	2400/F(kHz)	300
0.490 ~ 1.705	24000/F(kHz)	30
1.705 ~ 30.0	30	30
30 ~ 88	10	3
88 ~ 216	150	3
216 ~ 960	200	3
Above 960	500	3

Note: 1. The lower limit shall apply at the transition frequencies.
 2. Emission level (dBuV/m) = $20 \log$ Emission level (uV/m).
 3. As shown in 15.35(b), for frequencies above 1000MHz, the field strength limits are based on average detector, however, the peak field strength of any emission shall not exceed the maximum permitted average limits, specified above by more than 20dB under any condition of modulation.



■ **Test Instruments**

Equipment	Manufacturer	Model Number	Serial Number	Cal. Date	Cal. Period
RF Pre-selector	Agilent	N9039A	MY46520256	01/08/2016	1 year
Spectrum Analyzer	Agilent	E4446A	MY46180578	01/08/2016	1 year
Pre Amplifier	Agilent	8449B	3008A02237	10/07/2015	1 year
				10/11/2016	1 year
Pre Amplifier	Agilent	8447D	2944A11119	01/11/2016	1 year
Broadband Antenna	Schwarzbeck	VULB9168	416	09/26/2016	1 year
Horn Antenna (1~18GHz)	SCHWARZBECK MESS-ELEKTRONIK	BBHA9120D	9120D-550	06/06/2016	1 year
Horn Antenna (18~40GHz)	ETS	3116	86467	09/05/2016	1 year
Microwave Cable	EMCI	EMC102-KM-KM- 14000	151001	02/23/2016	1 year
Microwave Cable	EMCI	EMC-104-SM-SM- 14000	140202	02/23/2016	1 year
Microwave Cable	EMCI	EMC104-SM-SM- 600	140301	02/23/2016	1 year
Test Site	ATL	TE01	888001	08/29/2016	1 year

Note: N.C.R. = No Calibration Request.

■ Setup

9kHz ~ 30MHz

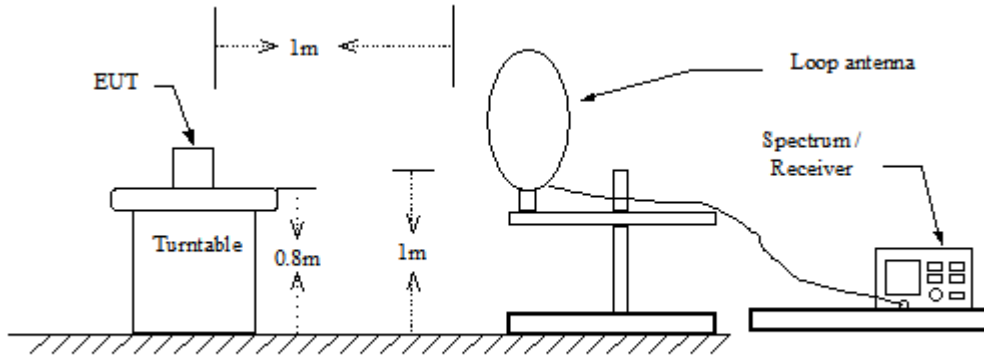

30MHz ~ 1GHz

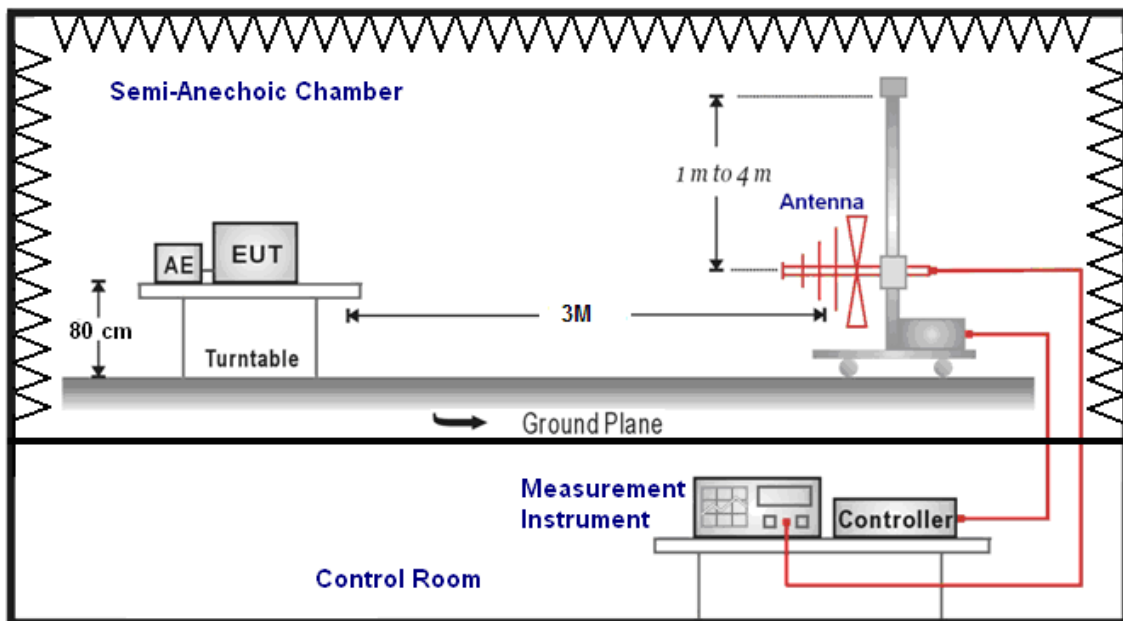

Above 1GHz

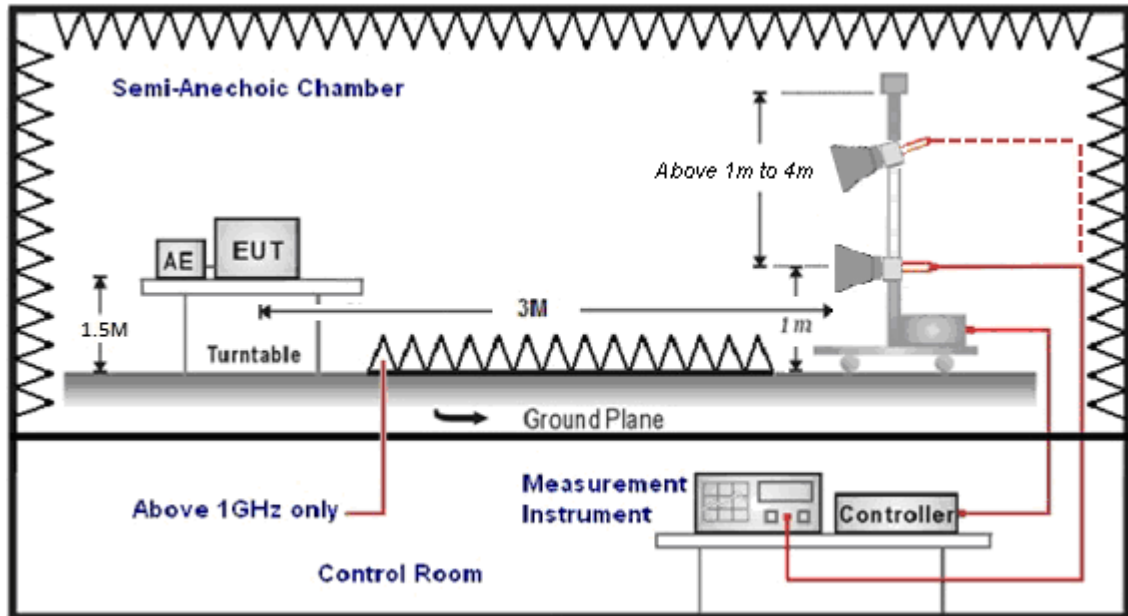

■ Test Procedure

Final radiation measurements were made on a three-meter, Semi Anechoic Chamber. The EUT system was placed on a nonconductive turntable which is 0.8 or 1.5 meters height (below 1GHz use 0.8m turntable / above 1GHz use 1.5m turntable), top surface 1.0 x 1.5 meter. The spectrum was examined from 250 MHz to 2.5 GHz in order to cover the whole spectrum below 10th harmonic which could generate from the EUT. During the test, EUT was set to transmit continuously & Measurements spectrum range from 9 kHz to 40 GHz is investigated.

For measurements below 1 GHz the resolution bandwidth is set to 100 kHz for peak detection measurements or 120 kHz for quasi-peak detection measurements. Peak detection is used unless otherwise noted as quasi-peak.

For restricted measurements above 1 GHz the resolution bandwidth is set to 1 MHz, and then the video bandwidth is set to 3 MHz for peak measurements and 10 Hz for average measurements when Duty cycle > 0.98 / 1/T for average measurements when Duty cycle < 0.98.

For out of band measurements above 1 GHz the resolution bandwidth is set to 1 MHz, and then the video bandwidth is set to 3 MHz for peak measurements.

A nonconductive material surrounded the EUT to supporting the EUT for standing on three orthogonal planes. At each condition, the EUT was rotated 360 degrees, and the antenna was raised and lowered from one to four meters to find the maximum emission levels. Measurements were taken using both horizontal and vertical antenna polarization.

SCHWARZBECK MESS-ELEKTRONIK Trilog-Broadband Antenna at 3 Meter and the ETS-Lindgren Double-Ridged Waveguide Horn antenna Schwarzbeck Mess-Elektronik Broadband Horn Antenna was used in frequencies 1 – 40 GHz at a distance of 3 meter. The antenna at an angle toward the source of the emission. All test results were extrapolated to equivalent signal at 3 meters utilizing an inverse linear distance extrapolation Factor (20dB/decade).



For testing above 1GHz, the emission level of the EUT in peak mode was 20dB lower than average limit (that means the emission level in peak mode also complies with the limit in average mode), then testing will be stopped and peak values of EUT will be reported, otherwise, the emissions will be measured in average mode again and reported.

Appropriate preamplifiers were used for improving sensitivity and precautions were taken to avoid overloading or desensitizing the spectrum analyzer. No post – detector video filters were used in the test.

The spectrum analyzer's 6 dB bandwidth was set to 1 MHz, and the analyzer was operated in the peak detection mode, for frequencies both below and up 1 GHz. The average levels were obtained by subtracting the duty cycle correction factor from the peak readings.

The following procedures were used to convert the emission levels measured in decibels referenced to 1 microvolt (dBuV) into field intensity in micro volts pre meter (uV/m).

The actual field intensity in decibels referenced to 1 microvolt in to field intensity in micro volts per meter (dBuV/m).

The actual field intensity in referenced to 1 microvolt per meter (dBuV/m) is determined by algebraically adding the measured reading in dBuV, the antenna factor (dB), and cable loss (dB) and Subtracting the gain of preamplifier (dB) is auto calculate in spectrum analyzer.

$$(1) \text{ Amplitude (dBuV/m) = FI (dBuV) +AF (dBuV) +CL (dBuV)-Gain (dB)}$$

FI= Reading of the field intensity.

AF= Antenna factor.

CL= Cable loss.

P.S Amplitude is auto calculate in spectrum analyzer.

$$(2) \text{ Actual Amplitude (dBuV/m) = Amplitude (dBuV)-Dis(dB)}$$

The FCC specified emission limits were calculated according the EUT operating frequency and by following linear interpolation equations:

(a) For fundamental frequency : Transmitter Output < +30dBm

(b) For spurious frequency : Spurious emission limits = fundamental emission limit /10

Measuring Instruments and setting

The following table is the setting of spectrum analyzer and receiver.

Spectrum Parameter	Setting
Attenuation	Auto
Start Frequency	1000MHz
Stop Frequency	40GHz
RBW/VBW(Emission in restricted band)	1MHz / 3MHz for Peak 1MHz / (1/T) for Average
RBW/VBW(Emission in non-restricted band)	1MHz / 3MHz for Peak



■ **Test Result**

Below 1GHz

Standard:	FCC Part 15E	Test Distance:	3m				
Test item:	Transmitter Radiated Emissions	Power:	AC 120V/60Hz				
Test Mode:	Mode 1	Temp.(°C)/Hum.(%RH):	26(°C)/60%RH				
		Date:	09/30/2016				
Internal Antenna							
Frequency (MHz)	Reading (dBuV)	Correct Factor (dB/m)	Result (dBuV/m)	Limit (dBuV/m)	Margin (dB)	Remark	Ant.Polar. H / V
222.0000	31.70	-7.34	24.36	46.00	-21.64	QP	H
468.0000	33.33	0.16	33.49	46.00	-12.51	QP	H
498.0000	39.23	0.71	39.94	46.00	-6.06	QP	H
594.0000	37.39	2.74	40.13	46.00	-5.87	QP	H
618.0000	34.70	3.28	37.98	46.00	-8.02	QP	H
672.0000	28.72	4.23	32.95	46.00	-13.05	QP	H
228.0000	40.14	-7.22	32.92	46.00	-13.08	QP	V
498.0000	39.81	0.71	40.52	46.00	-5.48	QP	V
510.0000	39.80	0.88	40.68	46.00	-5.32	QP	V
570.0000	39.80	2.05	41.85	46.00	-4.15	QP	V
582.0000	38.09	2.39	40.48	46.00	-5.52	QP	V
594.0000	37.70	2.74	40.44	46.00	-5.56	QP	V

- Note: 1. No emission found between lowest internal used/generated frequency to 30MHz (9kHz~30MHz).
 2. Result = Correction factor + Reading
 3. Correction factor = Antenna Factor + Cable loss – Pre-Amplifier gain.



Above 1GHz

Standard:	FCC Part 15.407	Test Distance:	3m
Test item:	Harmonic	Power:	AC 120V/60Hz
Frequency:	5260MHz	Temp.(°C)/Hum.(%RH):	26(°C)/60%RH
Mode:	Mode 2	Date:	11/19/2016
Ant.Polar.:	Horizontal		

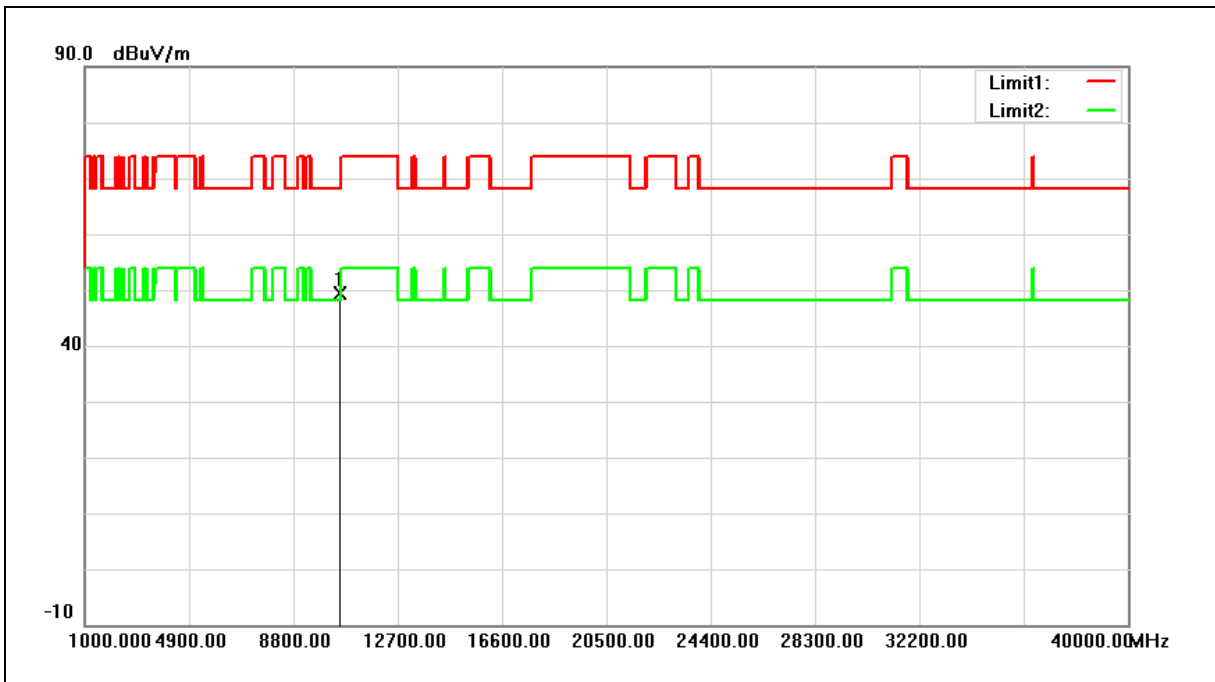

No.	Frequency (MHz)	Reading (dBuV)	Correct Factor (dB/m)	Result (dBuV/m)	Limit (dBuV/m)	Margin (dB)	Remark
1	10520.000	44.00	5.33	49.33	68.20	-18.87	peak

Note:1.Result (dBuV/m) = Correct Factor (dB/m) + Reading(dBuV).

2.Correction factor (dB/m) = Antenna Factor (dB/m) + Cable loss (dB) – Pre-Amplifier gain (dB).

3. When the peak results are less than average limit, so not need to evaluate the average.



Standard:	FCC Part 15.407	Test Distance:	3m
Test item:	Harmonic	Power:	AC 120V/60Hz
Frequency:	5260MHz	Temp.(°C)/Hum.(%RH):	26(°C)/60%RH
Mode:	Mode 2	Date:	11/19/2016
Ant.Polar.:	Vertical		

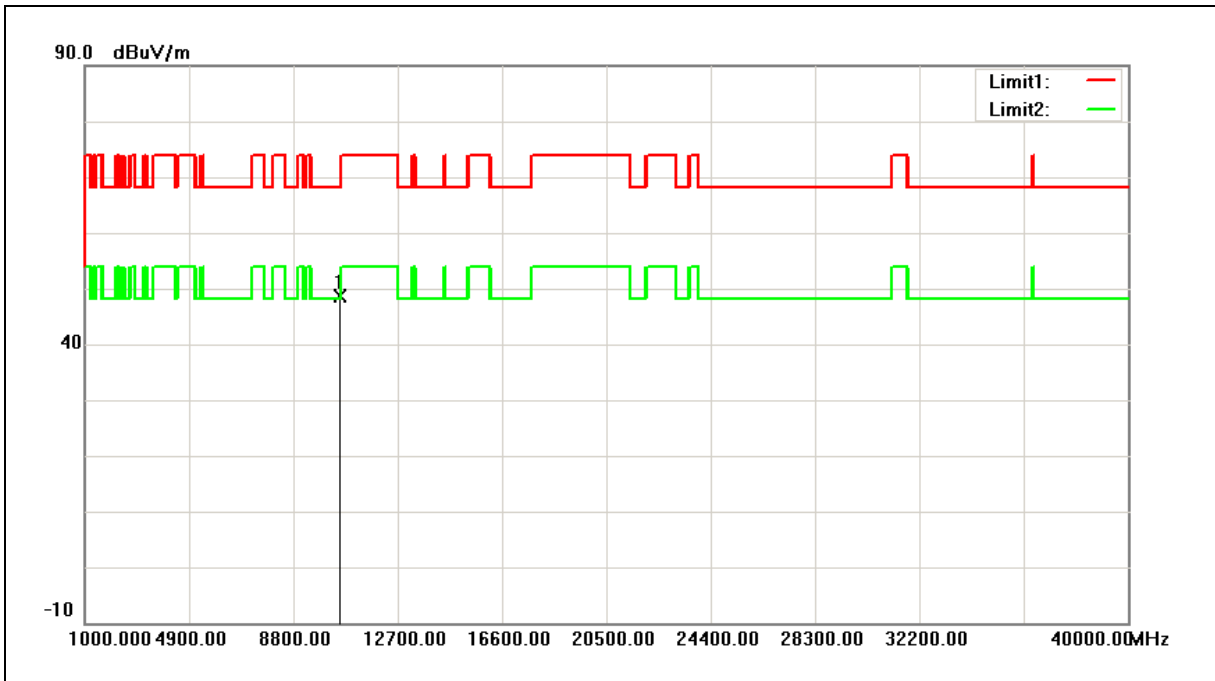

No.	Frequency (MHz)	Reading (dBuV)	Correct Factor (dB/m)	Result (dBuV/m)	Limit (dBuV/m)	Margin (dB)	Remark
1	10520.000	43.32	5.33	48.65	68.20	-19.55	peak

- Note:1.Result (dBuV/m) = Correct Factor (dB/m) + Reading(dBuV).
- 2.Correction factor (dB/m) = Antenna Factor (dB/m) + Cable loss (dB) – Pre-Amplifier gain (dB).
3. When the peak results are less than average limit, so not need to evaluate the average.



Standard:	FCC Part 15.407	Test Distance:	3m
Test item:	Harmonic	Power:	AC 120V/60Hz
Frequency:	5280MHz	Temp.(°C)/Hum.(%RH):	26(°C)/60%RH
Mode:	Mode 2	Date:	11/19/2016
Ant.Polar.:	Horizontal		

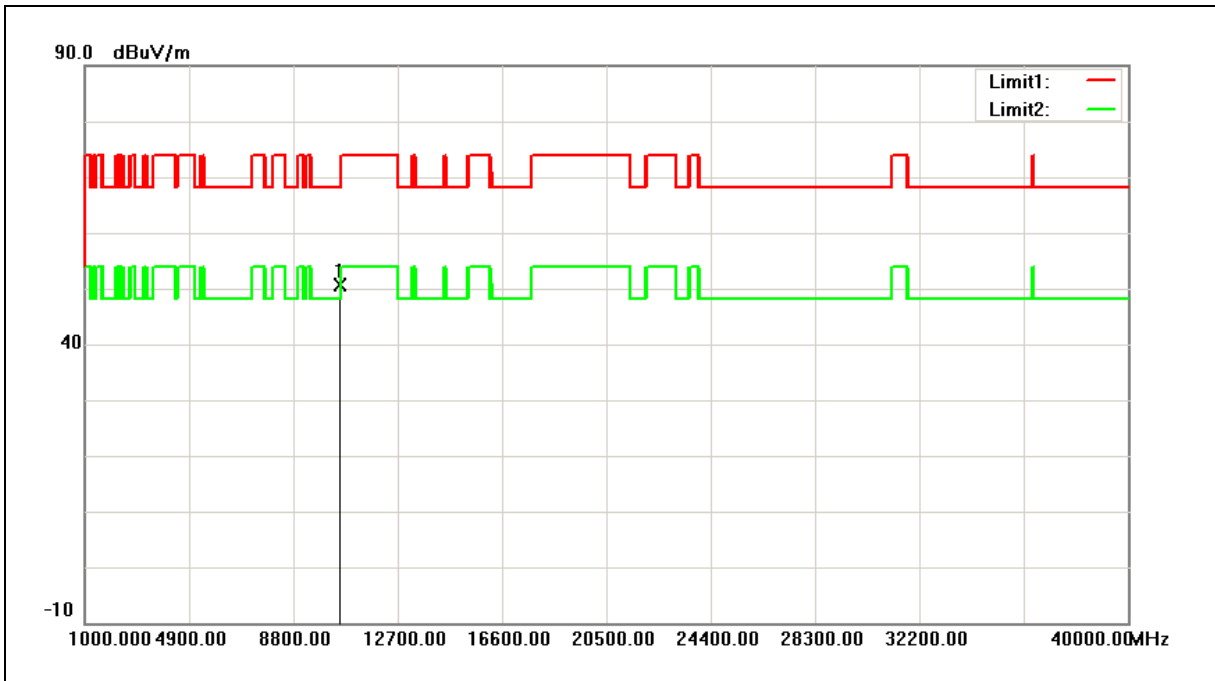

No.	Frequency (MHz)	Reading (dBuV)	Correct Factor (dB/m)	Result (dBuV/m)	Limit (dBuV/m)	Margin (dB)	Remark
1	10560.000	45.28	5.37	50.65	68.20	-17.55	peak

- Note:1.Result (dBuV/m) = Correct Factor (dB/m) + Reading(dBuV).
- 2.Correction factor (dB/m) = Antenna Factor (dB/m) + Cable loss (dB) – Pre-Amplifier gain (dB).
3. When the peak results are less than average limit, so not need to evaluate the average.



Standard:	FCC Part 15.407	Test Distance:	3m
Test item:	Harmonic	Power:	AC 120V/60Hz
Frequency:	5280MHz	Temp.(°C)/Hum.(%RH):	26(°C)/60%RH
Mode:	Mode 2	Date:	11/19/2016
Ant.Polar.:	Vertical		

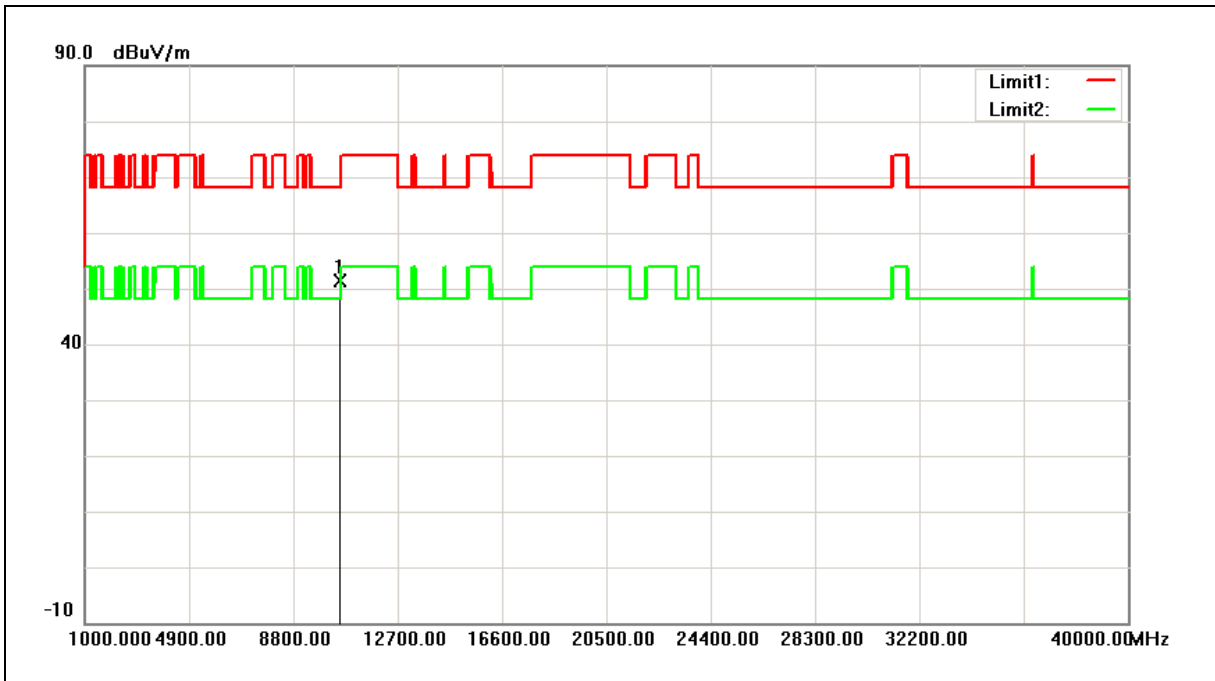

No.	Frequency (MHz)	Reading (dBuV)	Correct Factor (dB/m)	Result (dBuV/m)	Limit (dBuV/m)	Margin (dB)	Remark
1	10560.000	45.93	5.37	51.30	68.20	-16.90	peak

- Note:1.Result (dBuV/m) = Correct Factor (dB/m) + Reading(dBuV).
- 2.Correction factor (dB/m) = Antenna Factor (dB/m) + Cable loss (dB) – Pre-Amplifier gain (dB).
3. When the peak results are less than average limit, so not need to evaluate the average.



Standard:	FCC Part 15.407	Test Distance:	3m
Test item:	Harmonic	Power:	AC 120V/60Hz
Frequency:	5320MHz	Temp.(°C)/Hum.(%RH):	26(°C)/60%RH
Mode:	Mode 2	Date:	11/19/2016
Ant.Polar.:	Horizontal		

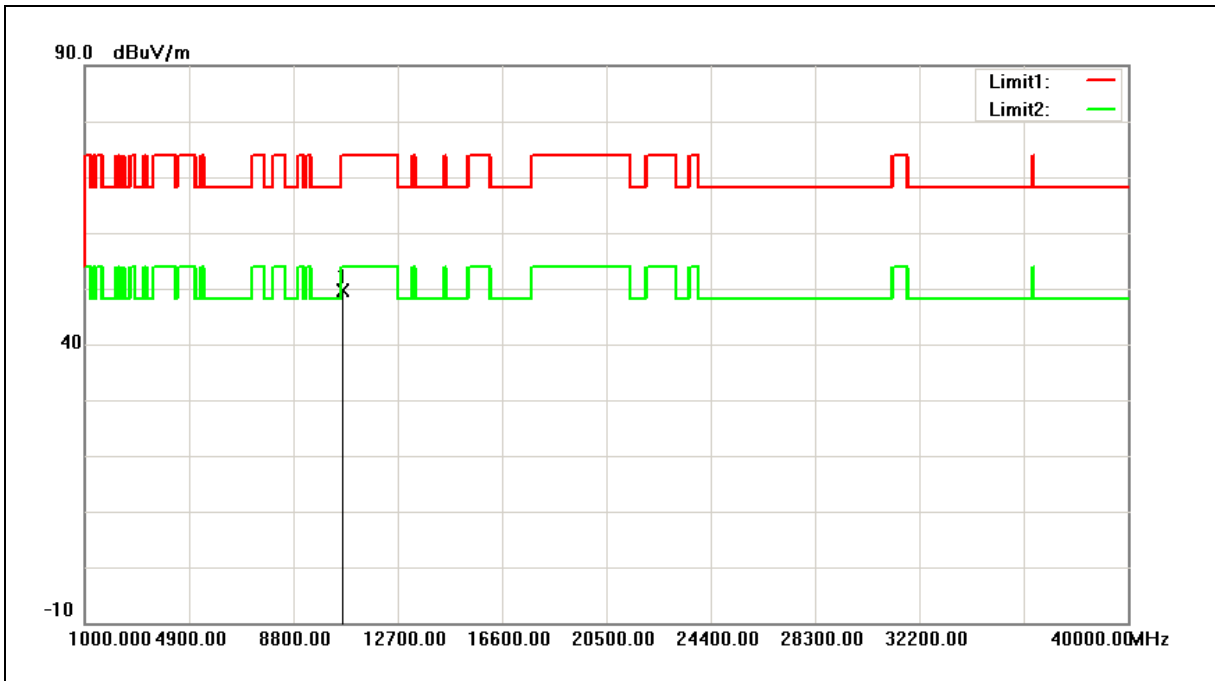

No.	Frequency (MHz)	Reading (dBuV)	Correct Factor (dB/m)	Result (dBuV/m)	Limit (dBuV/m)	Margin (dB)	Remark
1	10640.000	44.09	5.45	49.54	74.00	-24.46	peak

- Note:1.Result (dBuV/m) = Correct Factor (dB/m) + Reading(dBuV).
- 2.Correction factor (dB/m) = Antenna Factor (dB/m) + Cable loss (dB) – Pre-Amplifier gain (dB).
3. When the peak results are less than average limit, so not need to evaluate the average.



Standard:	FCC Part 15.407	Test Distance:	3m
Test item:	Harmonic	Power:	AC 120V/60Hz
Frequency:	5320MHz	Temp.(°C)/Hum.(%RH):	26(°C)/60%RH
Mode:	Mode 2	Date:	11/19/2016
Ant.Polar.:	Vertical		

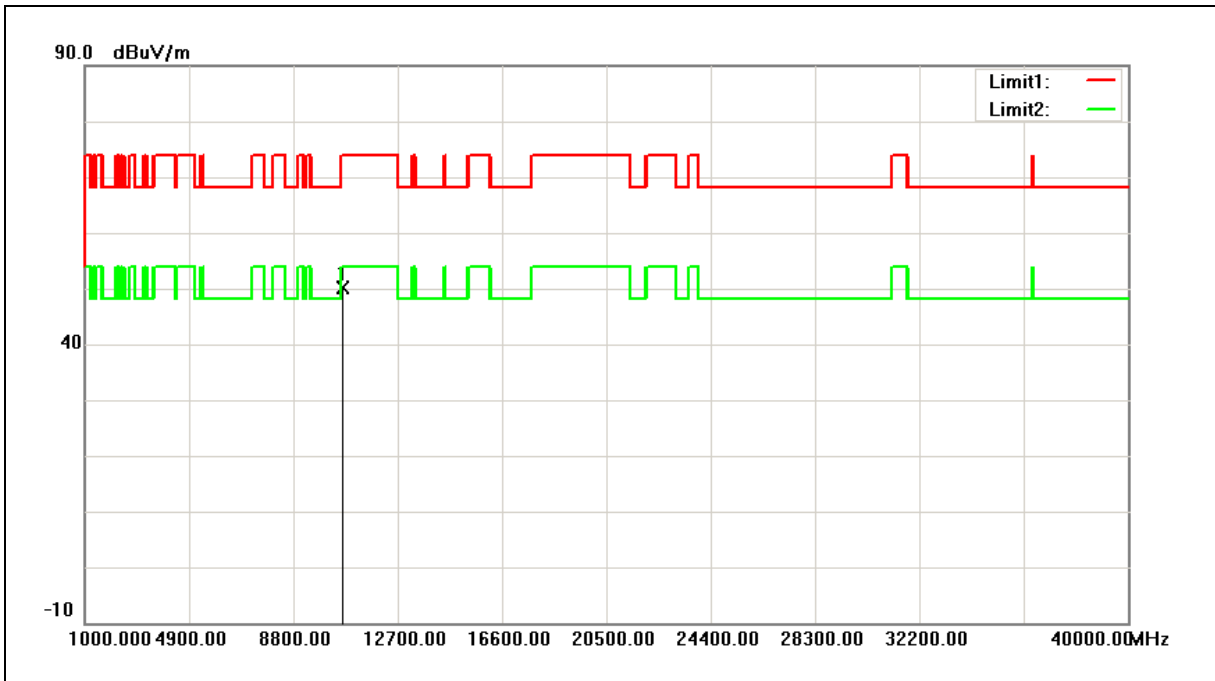

No.	Frequency (MHz)	Reading (dBuV)	Correct Factor (dB/m)	Result (dBuV/m)	Limit (dBuV/m)	Margin (dB)	Remark
1	10640.000	44.57	5.45	50.02	74.00	-23.98	peak

- Note:1.Result (dBuV/m) = Correct Factor (dB/m) + Reading(dBuV).
- 2.Correction factor (dB/m) = Antenna Factor (dB/m) + Cable loss (dB) – Pre-Amplifier gain (dB).
3. When the peak results are less than average limit, so not need to evaluate the average.



Standard:	FCC Part 15.407	Test Distance:	3m
Test item:	Harmonic	Power:	AC 120V/60Hz
Frequency:	5260MHz	Temp.(°C)/Hum.(%RH):	26(°C)/60%RH
Mode:	Mode 3	Date:	11/19/2016
Ant.Polar.:	Horizontal		

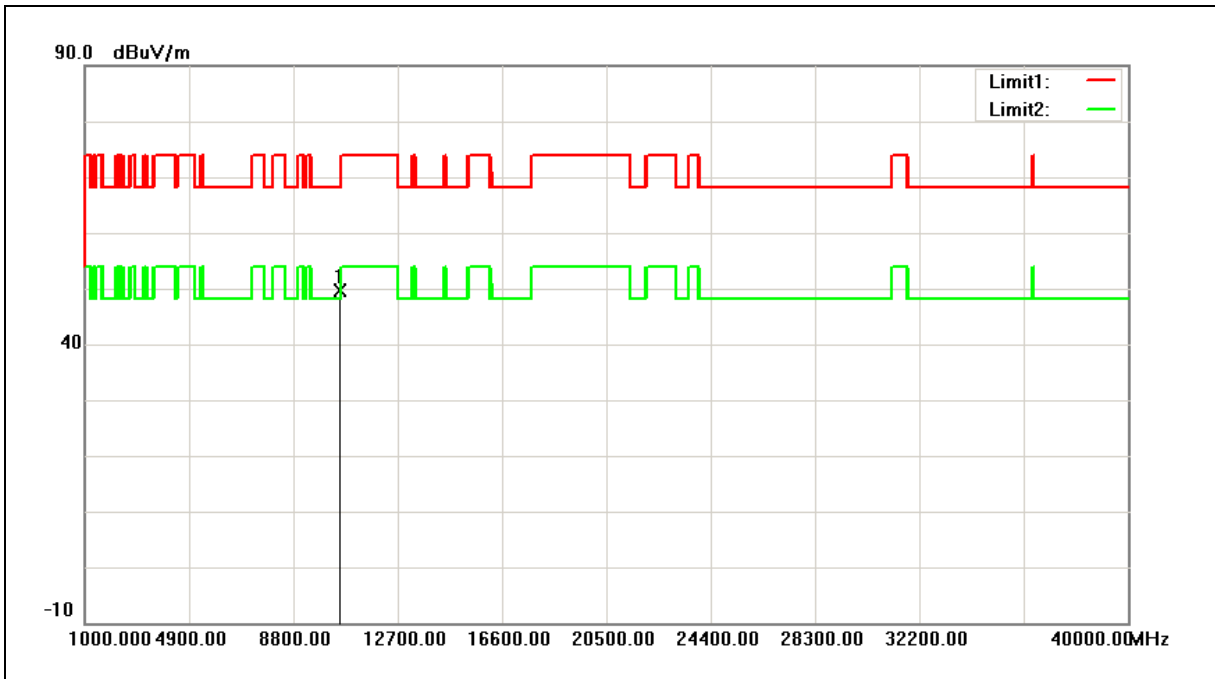

No.	Frequency (MHz)	Reading (dBuV)	Correct Factor (dB/m)	Result (dBuV/m)	Limit (dBuV/m)	Margin (dB)	Remark
1	10520.000	44.27	5.33	49.60	68.20	-18.60	peak

- Note:1.Result (dBuV/m) = Correct Factor (dB/m) + Reading(dBuV).
- 2.Correction factor (dB/m) = Antenna Factor (dB/m) + Cable loss (dB) – Pre-Amplifier gain (dB).
3. When the peak results are less than average limit, so not need to evaluate the average.



Standard:	FCC Part 15.407	Test Distance:	3m
Test item:	Harmonic	Power:	AC 120V/60Hz
Frequency:	5260MHz	Temp.(°C)/Hum.(%RH):	26(°C)/60%RH
Mode:	Mode 3	Date:	11/19/2016
Ant.Polar.:	Vertical		

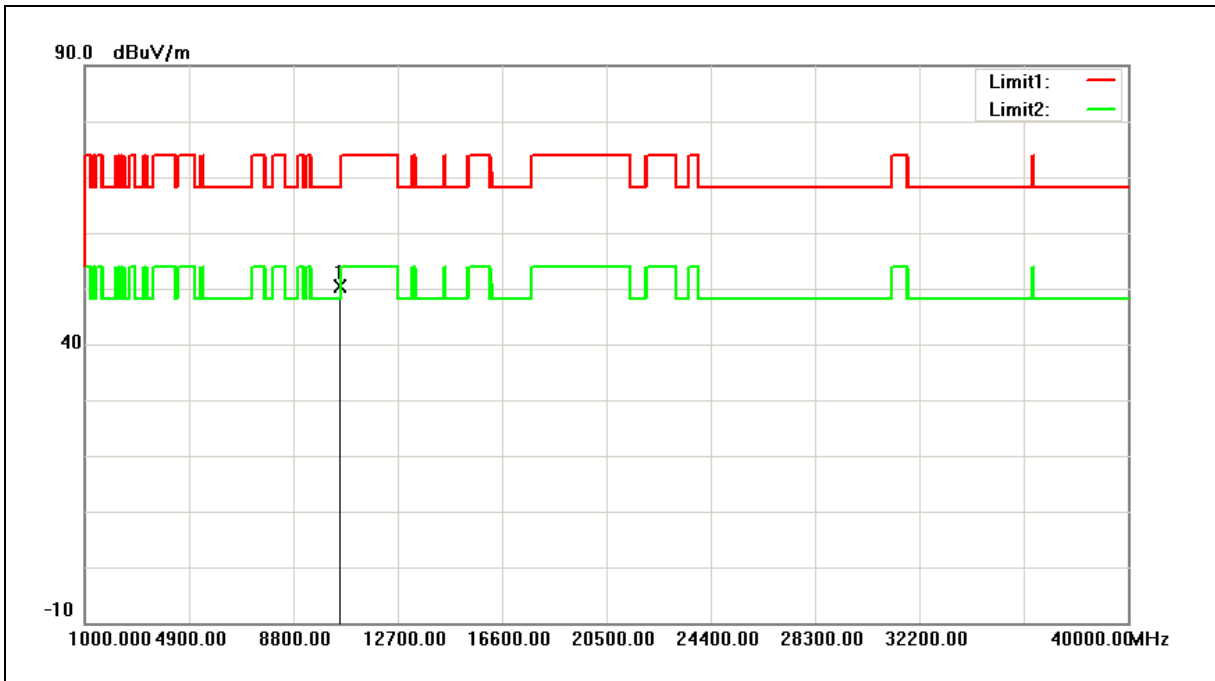

No.	Frequency (MHz)	Reading (dBuV)	Correct Factor (dB/m)	Result (dBuV/m)	Limit (dBuV/m)	Margin (dB)	Remark
1	10520.000	44.96	5.33	50.29	68.20	-17.91	peak

- Note:1.Result (dBuV/m) = Correct Factor (dB/m) + Reading(dBuV).
- 2.Correction factor (dB/m) = Antenna Factor (dB/m) + Cable loss (dB) – Pre-Amplifier gain (dB).
3. When the peak results are less than average limit, so not need to evaluate the average.



Standard:	FCC Part 15.407	Test Distance:	3m
Test item:	Harmonic	Power:	AC 120V/60Hz
Frequency:	5280MHz	Temp.(°C)/Hum.(%RH):	26(°C)/60%RH
Mode:	Mode 3	Date:	11/19/2016
Ant.Polar.:	Horizontal		

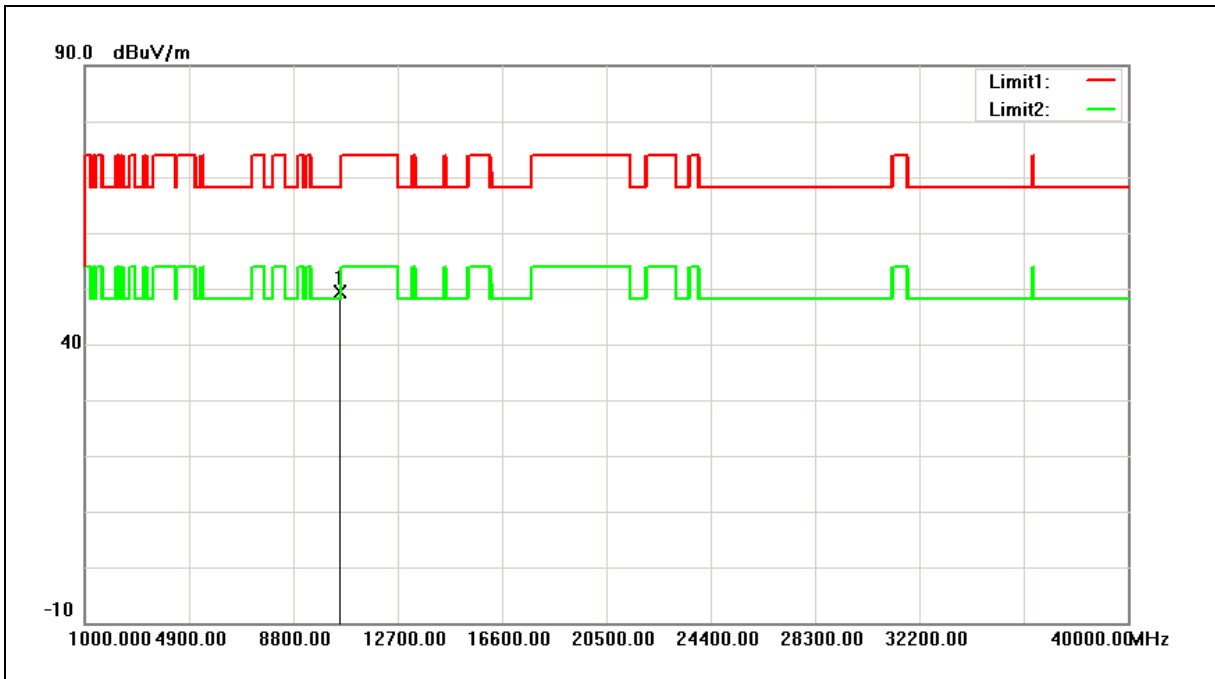

No.	Frequency (MHz)	Reading (dBuV)	Correct Factor (dB/m)	Result (dBuV/m)	Limit (dBuV/m)	Margin (dB)	Remark
1	10560.000	43.99	5.37	49.36	68.20	-18.84	peak

- Note:1.Result (dBuV/m) = Correct Factor (dB/m) + Reading(dBuV).
- 2.Correction factor (dB/m) = Antenna Factor (dB/m) + Cable loss (dB) – Pre-Amplifier gain (dB).
3. When the peak results are less than average limit, so not need to evaluate the average.



Standard:	FCC Part 15.407	Test Distance:	3m
Test item:	Harmonic	Power:	AC 120V/60Hz
Frequency:	5280MHz	Temp.(°C)/Hum.(%RH):	26(°C)/60%RH
Mode:	Mode 3	Date:	11/19/2016
Ant.Polar.:	Vertical		

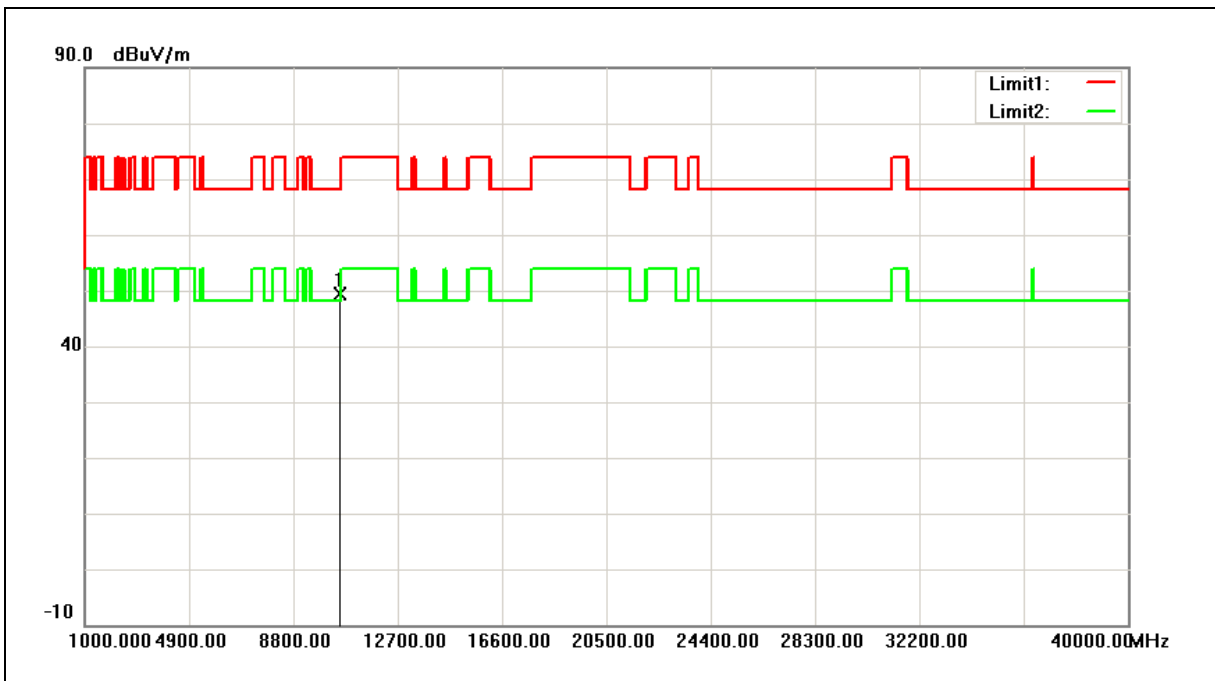

No.	Frequency (MHz)	Reading (dBuV)	Correct Factor (dB/m)	Result (dBuV/m)	Limit (dBuV/m)	Margin (dB)	Remark
1	10560.000	43.91	5.37	49.28	68.20	-18.92	peak

- Note:1.Result (dBuV/m) = Correct Factor (dB/m) + Reading(dBuV).
- 2.Correction factor (dB/m) = Antenna Factor (dB/m) + Cable loss (dB) – Pre-Amplifier gain (dB).
3. When the peak results are less than average limit, so not need to evaluate the average.



Standard:	FCC Part 15.407	Test Distance:	3m
Test item:	Harmonic	Power:	AC 120V/60Hz
Frequency:	5320MHz	Temp.(°C)/Hum.(%RH):	26(°C)/60%RH
Mode:	Mode 3	Date:	11/19/2016
Ant.Polar.:	Horizontal		

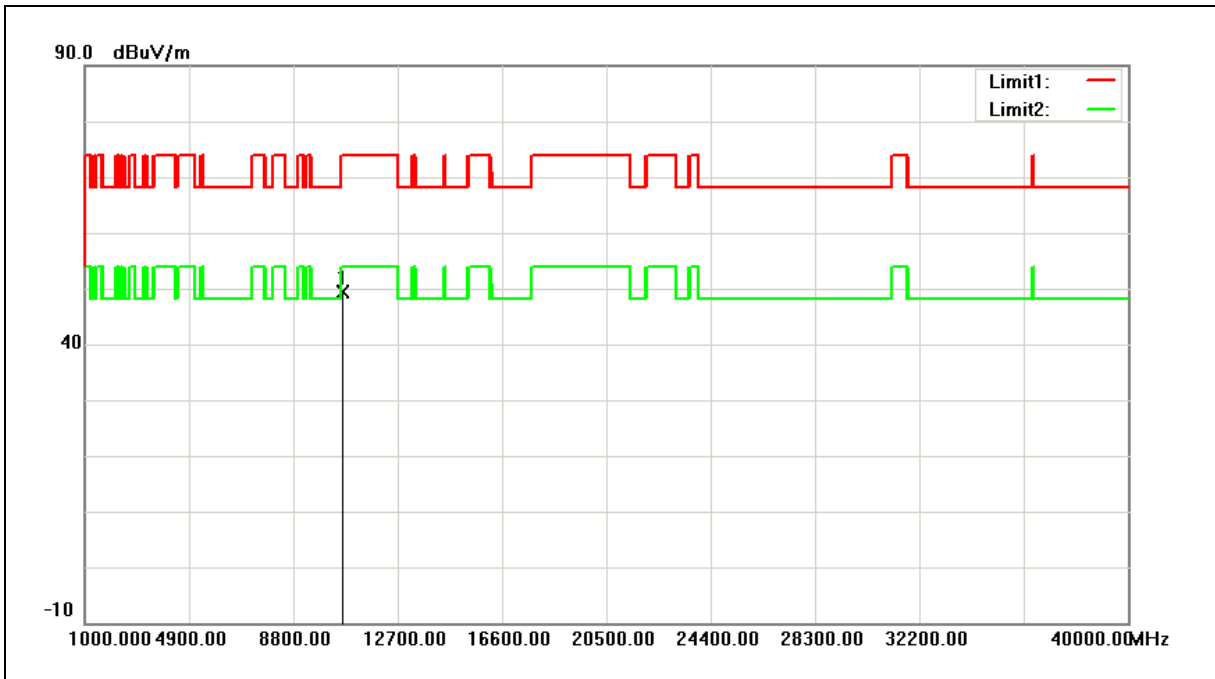

No.	Frequency (MHz)	Reading (dBuV)	Correct Factor (dB/m)	Result (dBuV/m)	Limit (dBuV/m)	Margin (dB)	Remark
1	10640.000	43.89	5.45	49.34	74.00	-24.66	peak

- Note:1.Result (dBuV/m) = Correct Factor (dB/m) + Reading(dBuV).
- 2.Correction factor (dB/m) = Antenna Factor (dB/m) + Cable loss (dB) – Pre-Amplifier gain (dB).
3. When the peak results are less than average limit, so not need to evaluate the average.



Standard:	FCC Part 15.407	Test Distance:	3m
Test item:	Harmonic	Power:	AC 120V/60Hz
Frequency:	5320MHz	Temp.(°C)/Hum.(%RH):	26(°C)/60%RH
Mode:	Mode 3	Date:	11/19/2016
Ant.Polar.:	Vertical		

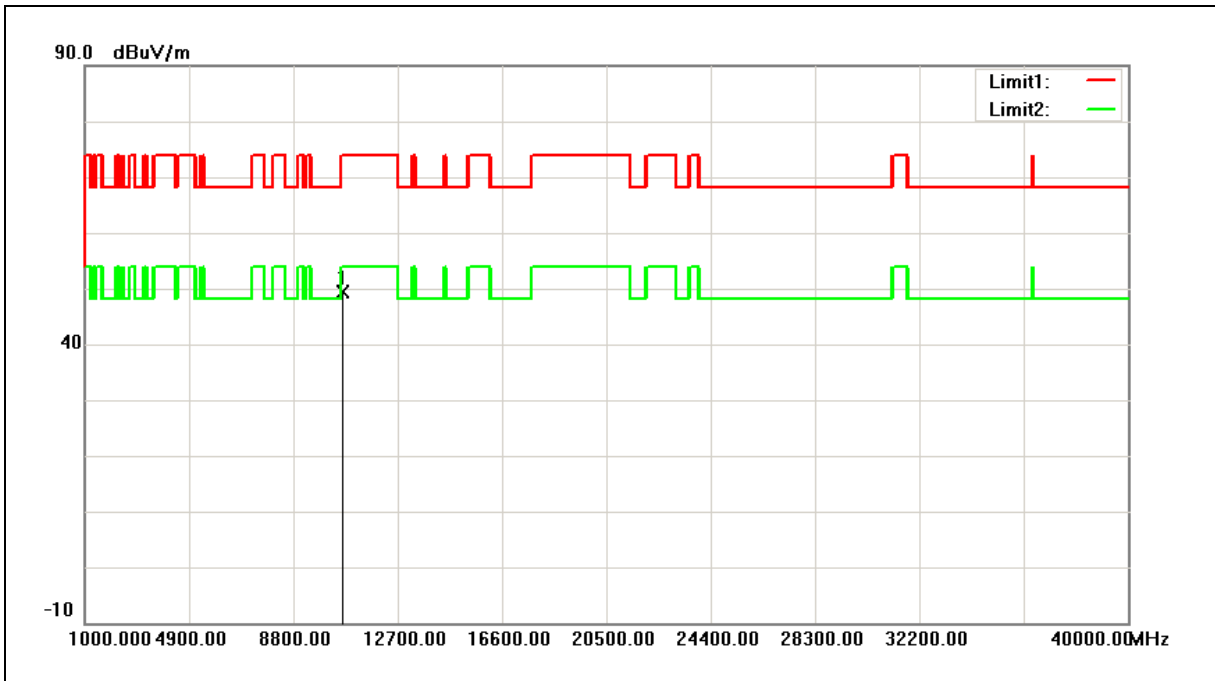

No.	Frequency (MHz)	Reading (dBuV)	Correct Factor (dB/m)	Result (dBuV/m)	Limit (dBuV/m)	Margin (dB)	Remark
1	10640.000	43.96	5.45	49.41	74.00	-24.59	peak

- Note:1.Result (dBuV/m) = Correct Factor (dB/m) + Reading(dBuV).
 2.Correction factor (dB/m) = Antenna Factor (dB/m) + Cable loss (dB) – Pre-Amplifier gain (dB).
 3. When the peak results are less than average limit, so not need to evaluate the average.



Standard:	FCC Part 15.407	Test Distance:	3m
Test item:	Harmonic	Power:	AC 120V/60Hz
Frequency:	5270MHz	Temp.(°C)/Hum.(%RH):	26(°C)/60%RH
Mode:	Mode 4	Date:	11/19/2016
Ant.Polar.:	Horizontal		

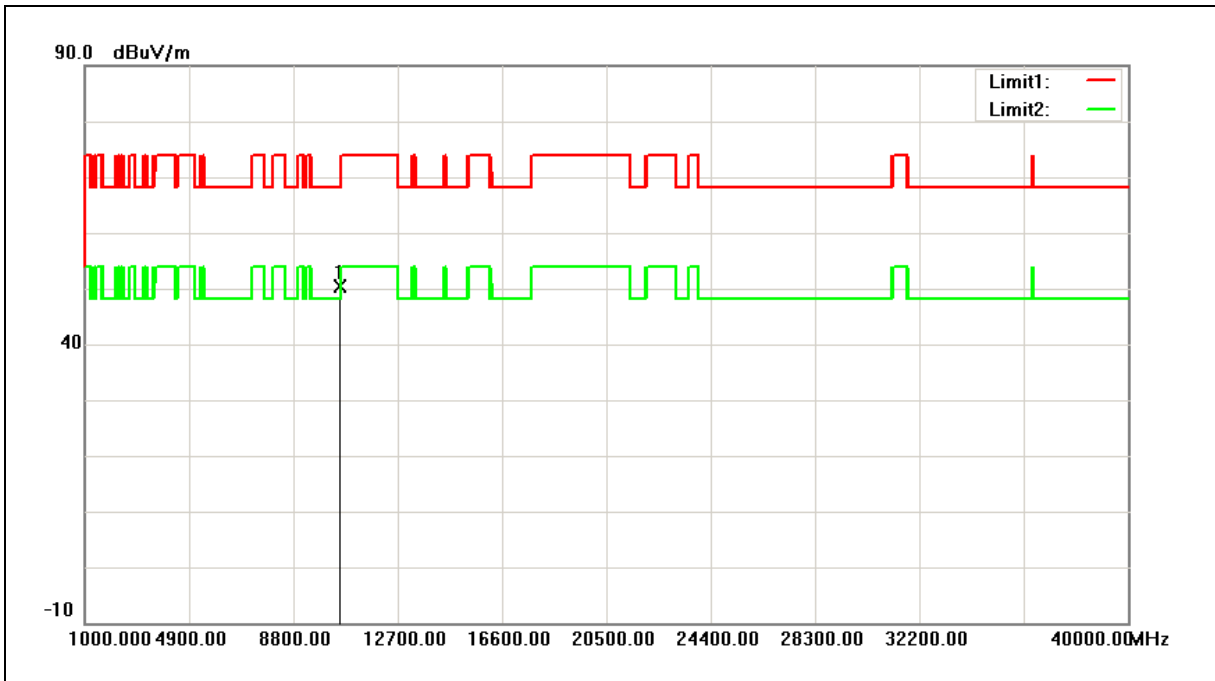

No.	Frequency (MHz)	Reading (dBuV)	Correct Factor (dB/m)	Result (dBuV/m)	Limit (dBuV/m)	Margin (dB)	Remark
1	10540.000	44.95	5.35	50.30	68.20	-17.90	peak

- Note:1.Result (dBuV/m) = Correct Factor (dB/m) + Reading(dBuV).
- 2.Correction factor (dB/m) = Antenna Factor (dB/m) + Cable loss (dB) – Pre-Amplifier gain (dB).
3. When the peak results are less than average limit, so not need to evaluate the average.



Standard:	FCC Part 15.407	Test Distance:	3m
Test item:	Harmonic	Power:	AC 120V/60Hz
Frequency:	5270MHz	Temp.(°C)/Hum.(%RH):	26(°C)/60%RH
Mode:	Mode 4	Date:	11/19/2016
Ant.Polar.:	Vertical		

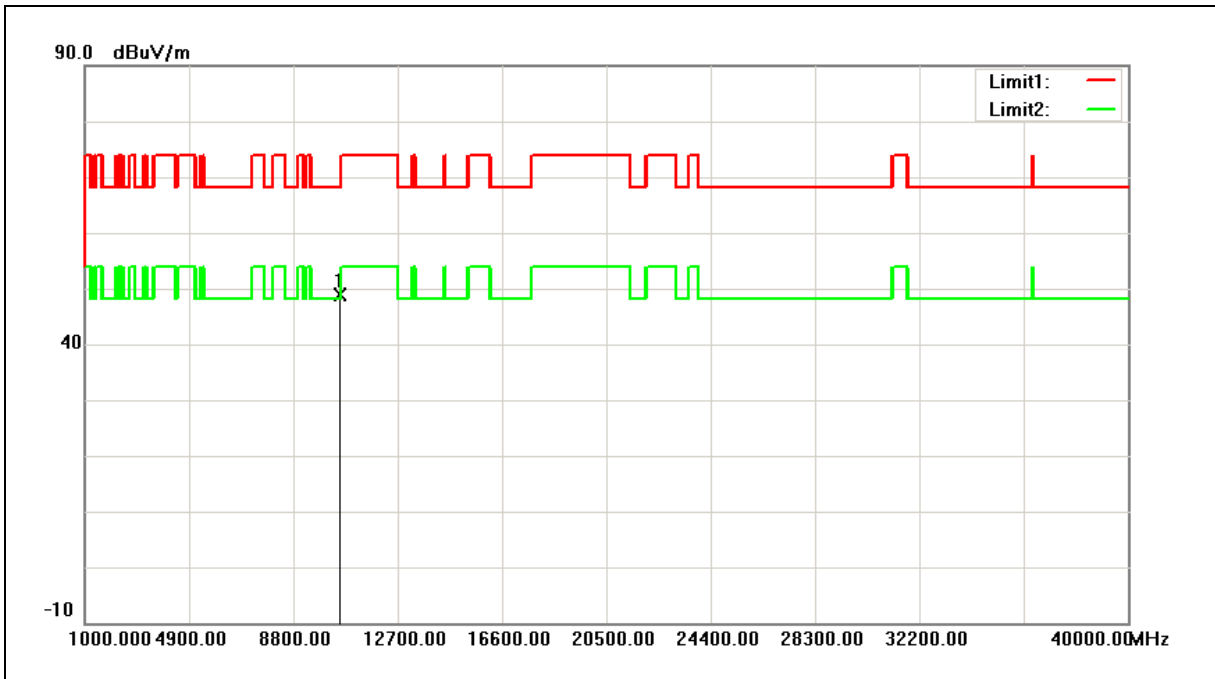

No.	Frequency (MHz)	Reading (dBuV)	Correct Factor (dB/m)	Result (dBuV/m)	Limit (dBuV/m)	Margin (dB)	Remark
1	10540.000	43.41	5.35	48.76	68.20	-19.44	peak

- Note:1.Result (dBuV/m) = Correct Factor (dB/m) + Reading(dBuV).
- 2.Correction factor (dB/m) = Antenna Factor (dB/m) + Cable loss (dB) – Pre-Amplifier gain (dB).
3. When the peak results are less than average limit, so not need to evaluate the average.



Standard:	FCC Part 15.407	Test Distance:	3m
Test item:	Harmonic	Power:	AC 120V/60Hz
Frequency:	5310MHz	Temp.(°C)/Hum.(%RH):	26(°C)/60%RH
Mode:	Mode 4	Date:	11/19/2016
Ant.Polar.:	Horizontal		

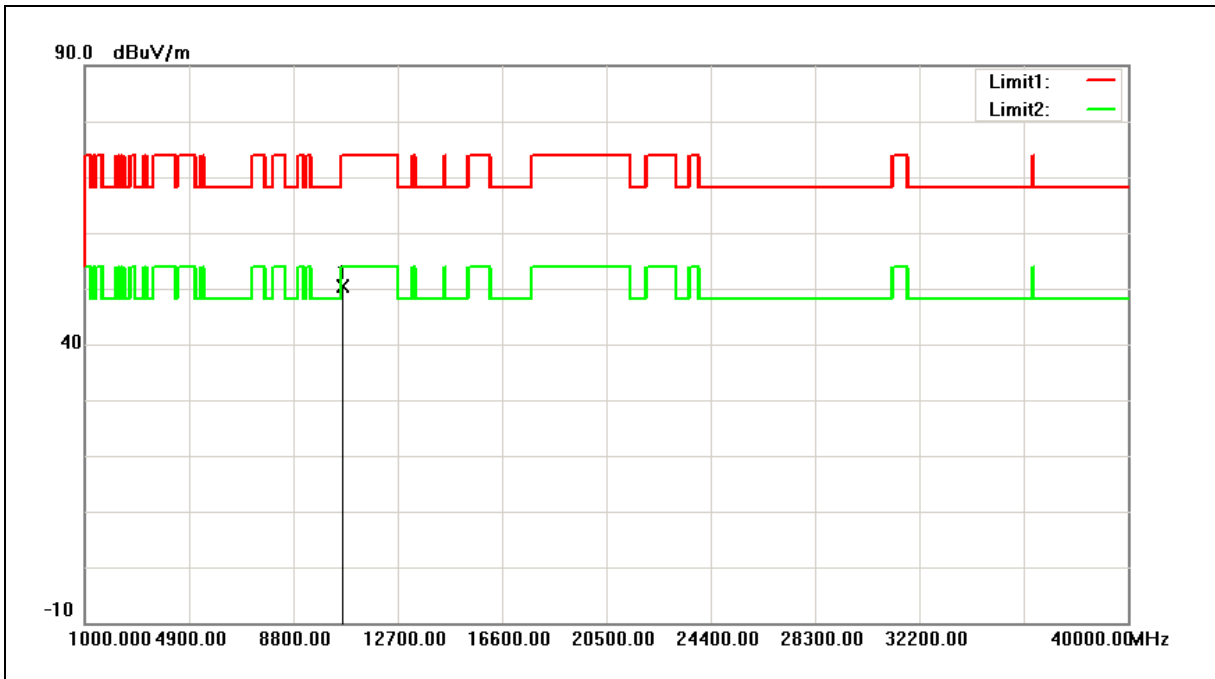

No.	Frequency (MHz)	Reading (dBuV)	Correct Factor (dB/m)	Result (dBuV/m)	Limit (dBuV/m)	Margin (dB)	Remark
1	10620.000	45.04	5.42	50.46	74.00	-23.54	peak

- Note:1.Result (dBuV/m) = Correct Factor (dB/m) + Reading(dBuV).
- 2.Correction factor (dB/m) = Antenna Factor (dB/m) + Cable loss (dB) – Pre-Amplifier gain (dB).
3. When the peak results are less than average limit, so not need to evaluate the average.



Standard:	FCC Part 15.407	Test Distance:	3m
Test item:	Harmonic	Power:	AC 120V/60Hz
Frequency:	5310MHz	Temp.(°C)/Hum.(%RH):	26(°C)/60%RH
Mode:	Mode 4	Date:	11/19/2016
Ant.Polar.:	Vertical		

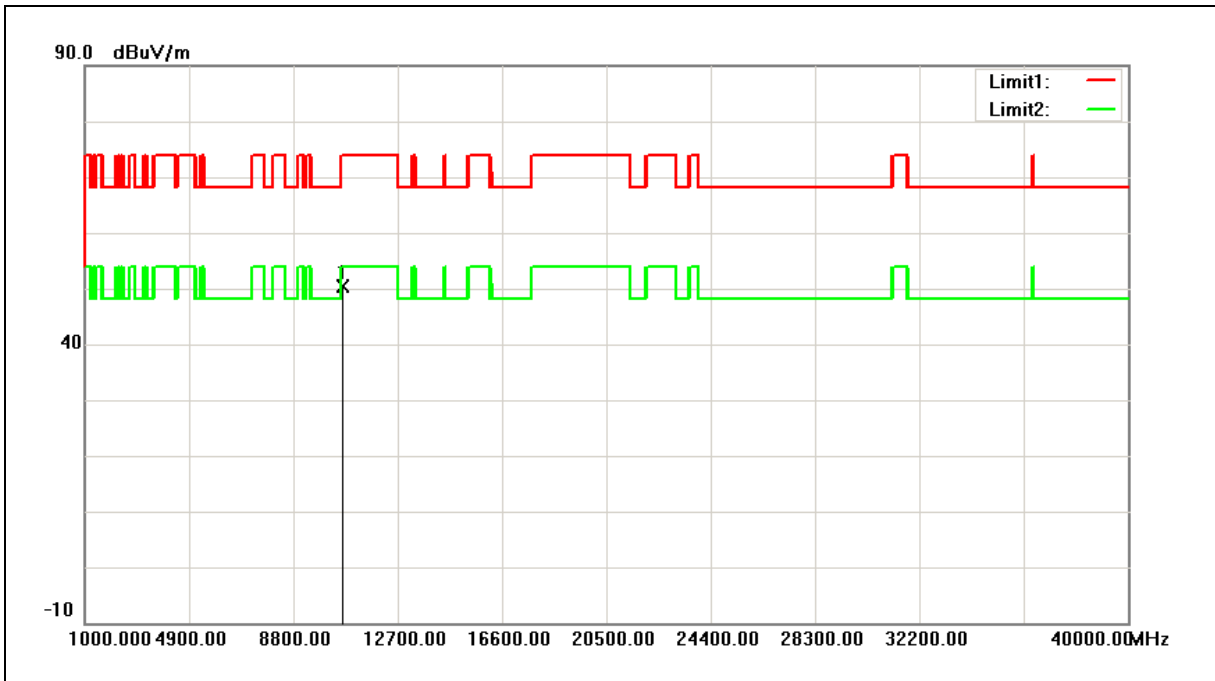

No.	Frequency (MHz)	Reading (dBuV)	Correct Factor (dB/m)	Result (dBuV/m)	Limit (dBuV/m)	Margin (dB)	Remark
1	10620.000	44.99	5.42	50.41	74.00	-23.59	peak

- Note:1.Result (dBuV/m) = Correct Factor (dB/m) + Reading(dBuV).
- 2.Correction factor (dB/m) = Antenna Factor (dB/m) + Cable loss (dB) – Pre-Amplifier gain (dB).
3. When the peak results are less than average limit, so not need to evaluate the average.



Standard:	FCC Part 15.407	Test Distance:	3m
Test item:	Harmonic	Power:	AC 120V/60Hz
Frequency:	5290MHz	Temp.(°C)/Hum.(%RH):	26(°C)/60%RH
Mode:	Mode 5	Date:	11/19/2016
Ant.Polar.:	Horizontal		

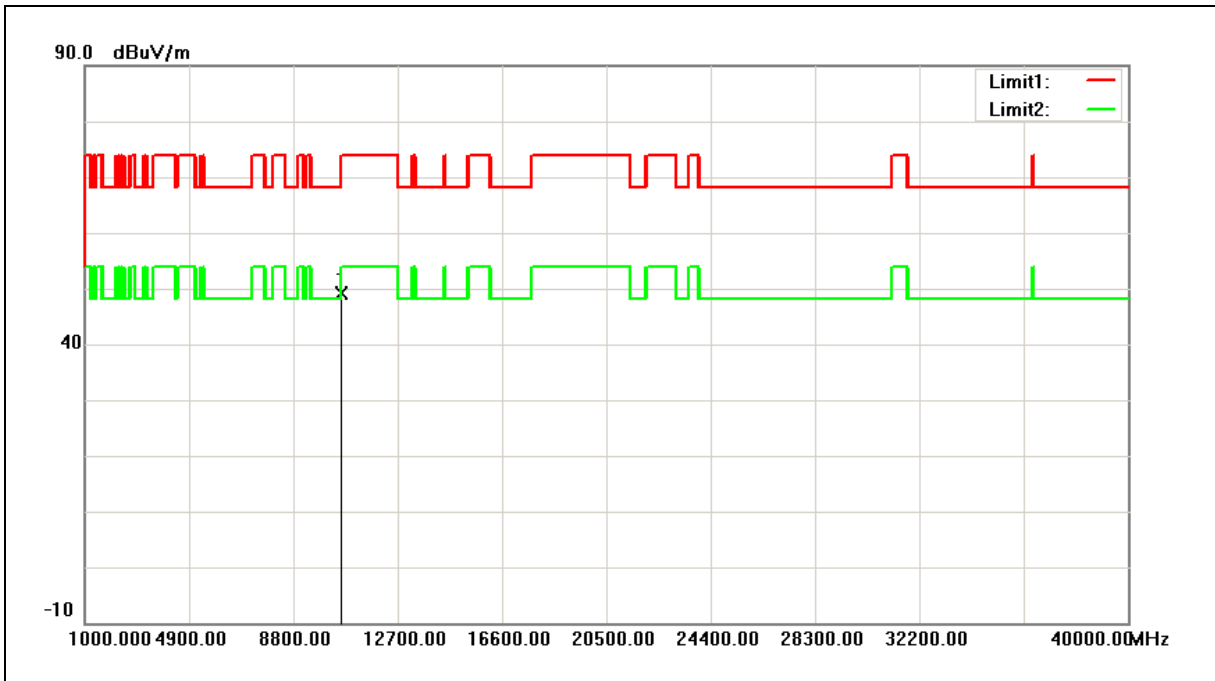

No.	Frequency (MHz)	Reading (dBuV)	Correct Factor (dB/m)	Result (dBuV/m)	Limit (dBuV/m)	Margin (dB)	Remark
1	10580.000	43.76	5.39	49.15	68.20	-19.05	peak

- Note:1.Result (dBuV/m) = Correct Factor (dB/m) + Reading(dBuV).
 2.Correction factor (dB/m) = Antenna Factor (dB/m) + Cable loss (dB) – Pre-Amplifier gain (dB).
 3. When the peak results are less than average limit, so not need to evaluate the average.



Standard:	FCC Part 15.407	Test Distance:	3m
Test item:	Harmonic	Power:	AC 120V/60Hz
Frequency:	5290MHz	Temp.(°C)/Hum.(%RH):	26(°C)/60%RH
Mode:	Mode 5	Date:	11/19/2016
Ant.Polar.:	Vertical		

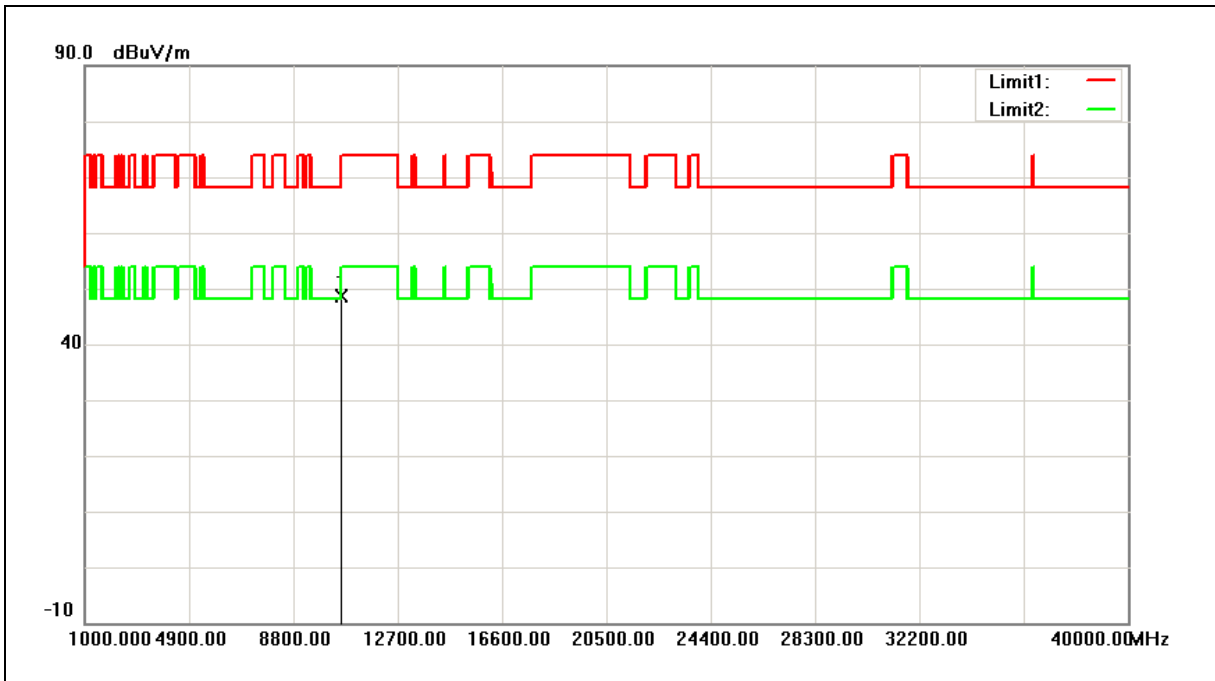

No.	Frequency (MHz)	Reading (dBuV)	Correct Factor (dB/m)	Result (dBuV/m)	Limit (dBuV/m)	Margin (dB)	Remark
1	10580.000	43.30	5.39	48.69	68.20	-19.51	peak

- Note:1.Result (dBuV/m) = Correct Factor (dB/m) + Reading(dBuV).
- 2.Correction factor (dB/m) = Antenna Factor (dB/m) + Cable loss (dB) – Pre-Amplifier gain (dB).
3. When the peak results are less than average limit, so not need to evaluate the average.



Band Edge

Standard:	FCC Part 15.407	Test Distance:	3m
Test item:	Band edge	Power:	AC 120V/60Hz
Frequency:	5320MHz	Temp.(°C)/Hum.(%RH):	26(°C)/60%RH
Mode:	Mode 2	Date:	11/19/2016
Ant.Polar.:	Horizontal		

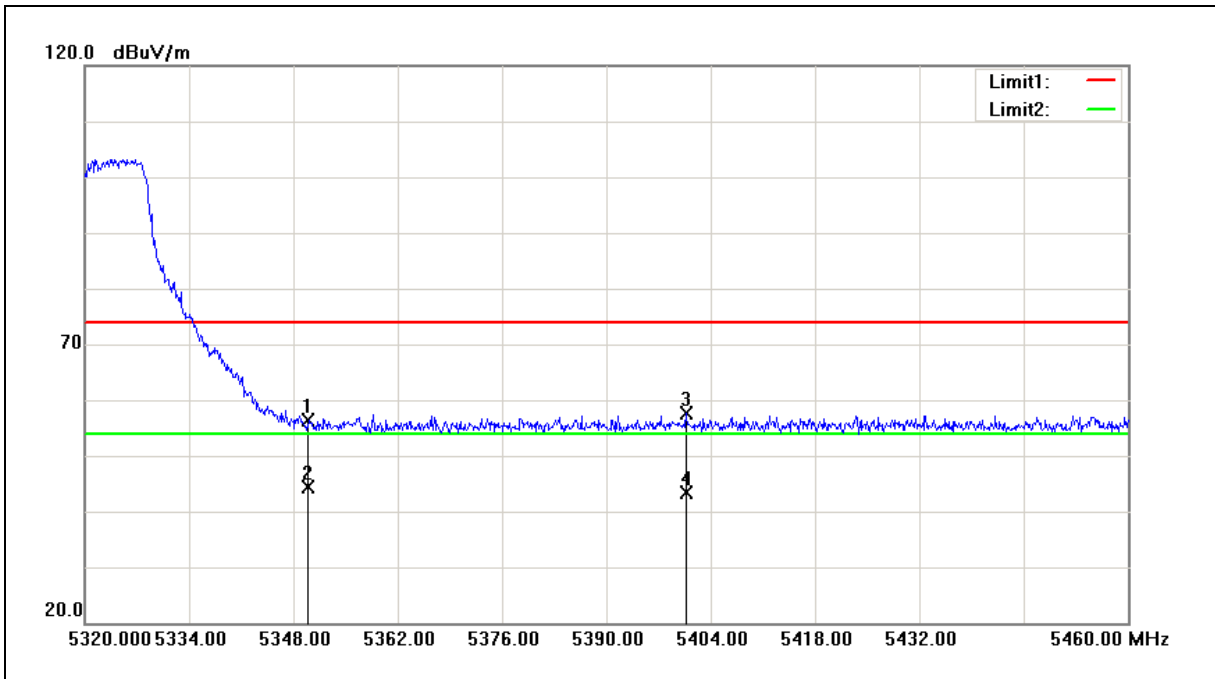

No.	Frequency (MHz)	Reading (dBuV)	Correct Factor (dB/m)	Result (dBuV/m)	Limit (dBuV/m)	Margin (dB)	Remark
1	5350.000	47.92	8.41	56.33	74.00	-17.67	peak
2	5350.000	35.92	8.41	44.33	54.00	-9.67	AVG
3	5400.640	49.11	8.47	57.58	74.00	-16.42	peak
4	5400.640	34.82	8.47	43.29	54.00	-10.71	AVG

Note:1.Result (dBuV/m) = Correct Factor (dB/m) + Reading(dBuV).

2.Correction factor (dB/m) = Antenna Factor (dB/m) + Cable loss (dB) – Pre-Amplifier gain (dB).

3. When the peak results are less than average limit, so not need to evaluate the average.



Standard:	FCC Part 15.407	Test Distance:	3m
Test item:	Band edge	Power:	AC 120V/60Hz
Frequency:	5320MHz	Temp.(°C)/Hum.(%RH):	26(°C)/60%RH
Mode:	Mode 2	Date:	11/19/2016
Ant.Polar.:	Vertical		

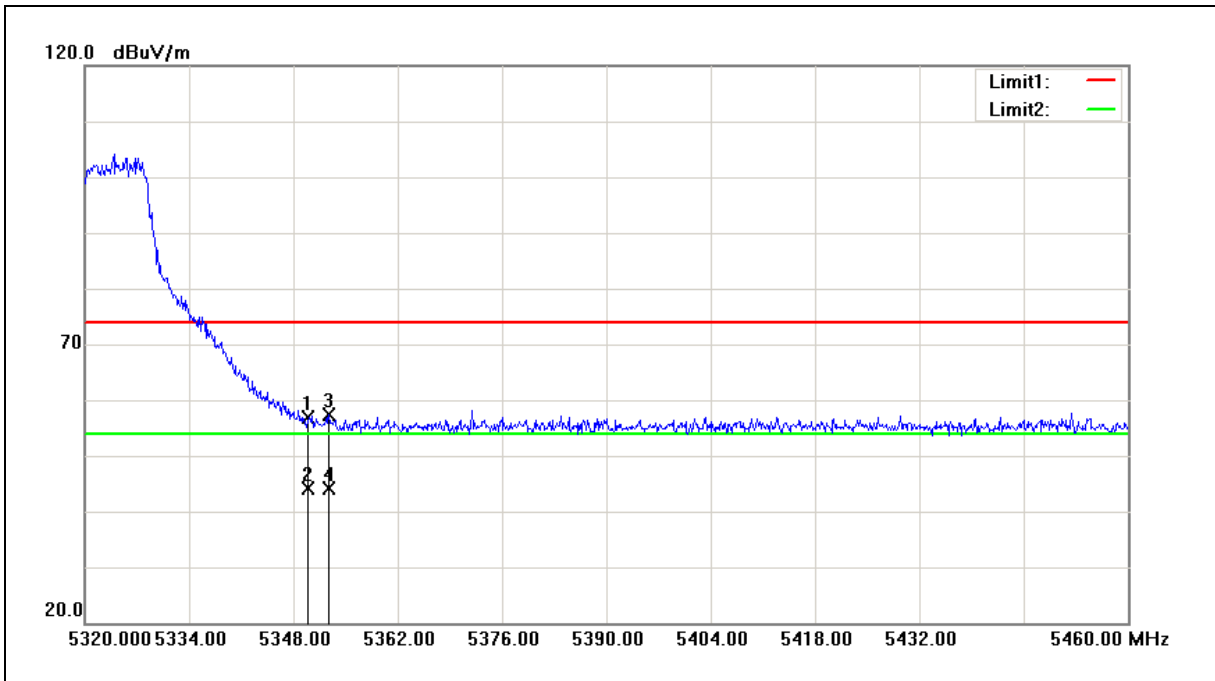

No.	Frequency (MHz)	Reading (dBuV)	Correct Factor (dB/m)	Result (dBuV/m)	Limit (dBuV/m)	Margin (dB)	Remark
1	5350.000	48.41	8.41	56.82	74.00	-17.18	peak
2	5350.000	35.71	8.41	44.12	54.00	-9.88	AVG
3	5352.760	48.94	8.42	57.36	74.00	-16.64	peak
4	5352.760	35.63	8.42	44.05	54.00	-9.95	AVG

- Note:1.Result (dBuV/m) = Correct Factor (dB/m) + Reading(dBuV).
- 2.Correction factor (dB/m) = Antenna Factor (dB/m) + Cable loss (dB) – Pre-Amplifier gain (dB).
3. When the peak results are less than average limit, so not need to evaluate the average.



Standard:	FCC Part 15.407	Test Distance:	3m
Test item:	Band edge	Power:	AC 120V/60Hz
Frequency:	5320MHz	Temp.(°C)/Hum.(%RH):	26(°C)/60%RH
Mode:	Mode 3	Date:	11/19/2016
Ant.Polar.:	Horizontal		

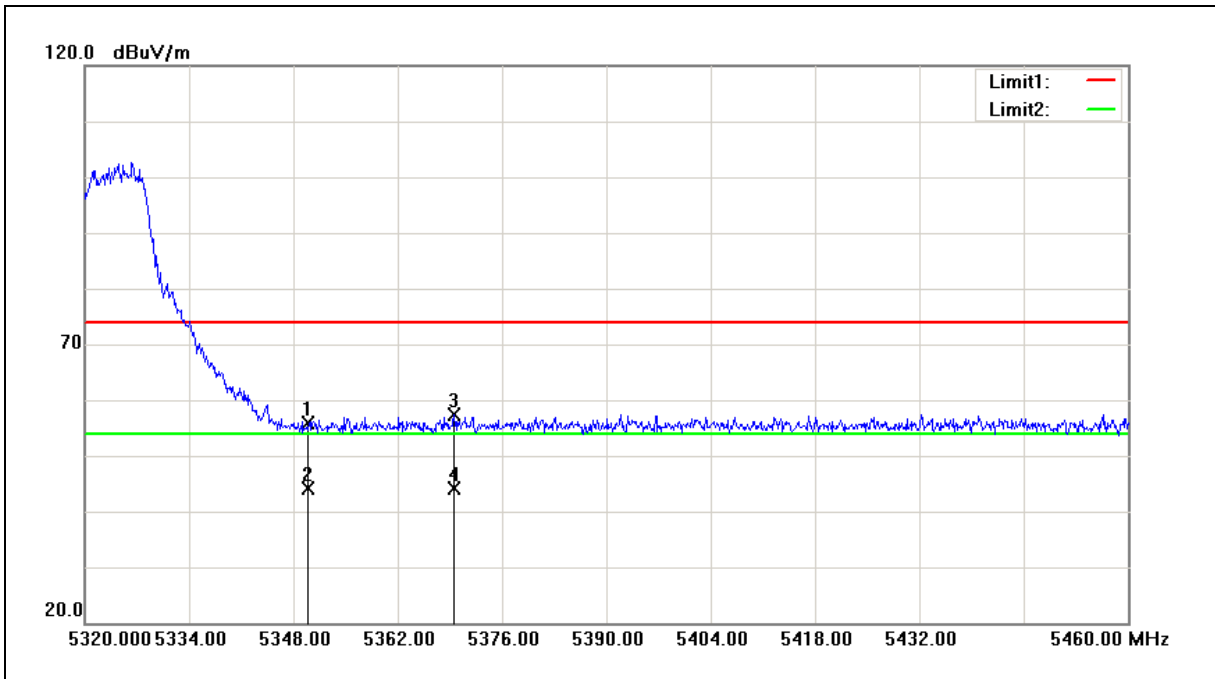

No.	Frequency (MHz)	Reading (dBuV)	Correct Factor (dB/m)	Result (dBuV/m)	Limit (dBuV/m)	Margin (dB)	Remark
1	5350.000	47.53	8.41	55.94	74.00	-18.06	peak
2	5350.000	35.69	8.41	44.10	54.00	-9.90	AVG
3	5369.560	49.06	8.43	57.49	74.00	-16.51	peak
4	5369.560	35.78	8.43	44.21	54.00	-9.79	AVG

- Note:1.Result (dBuV/m) = Correct Factor (dB/m) + Reading(dBuV).
- 2.Correction factor (dB/m) = Antenna Factor (dB/m) + Cable loss (dB) – Pre-Amplifier gain (dB).
3. When the peak results are less than average limit, so not need to evaluate the average.



Standard:	FCC Part 15.407	Test Distance:	3m
Test item:	Band edge	Power:	AC 120V/60Hz
Frequency:	5320MHz	Temp.(°C)/Hum.(%RH):	26(°C)/60%RH
Mode:	Mode 3	Date:	11/19/2016
Ant.Polar.:	Vertical		

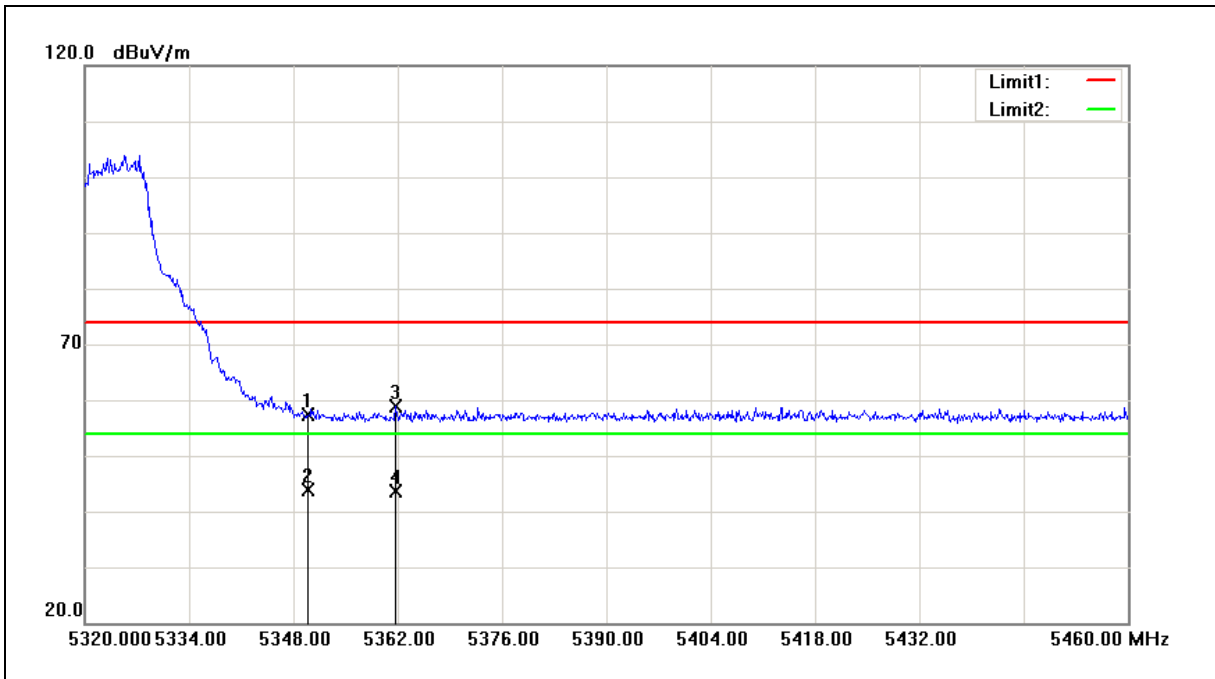

No.	Frequency (MHz)	Reading (dBuV)	Correct Factor (dB/m)	Result (dBuV/m)	Limit (dBuV/m)	Margin (dB)	Remark
1	5350.000	49.07	8.41	57.48	74.00	-16.52	peak
2	5350.000	35.36	8.41	43.77	54.00	-10.23	AVG
3	5361.720	50.45	8.42	58.87	74.00	-15.13	peak
4	5361.720	35.10	8.42	43.52	54.00	-10.48	AVG

Note:1.Result (dBuV/m) = Correct Factor (dB/m) + Reading(dBuV).

2.Correction factor (dB/m) = Antenna Factor (dB/m) + Cable loss (dB) – Pre-Amplifier gain (dB).

3. When the peak results are less than average limit, so not need to evaluate the average.



Standard:	FCC Part 15.407	Test Distance:	3m
Test item:	Band edge	Power:	AC 120V/60Hz
Frequency:	5310MHz	Temp.(°C)/Hum.(%RH):	26(°C)/60%RH
Mode:	Mode 4	Date:	11/19/2016
Ant.Polar.:	Horizontal		

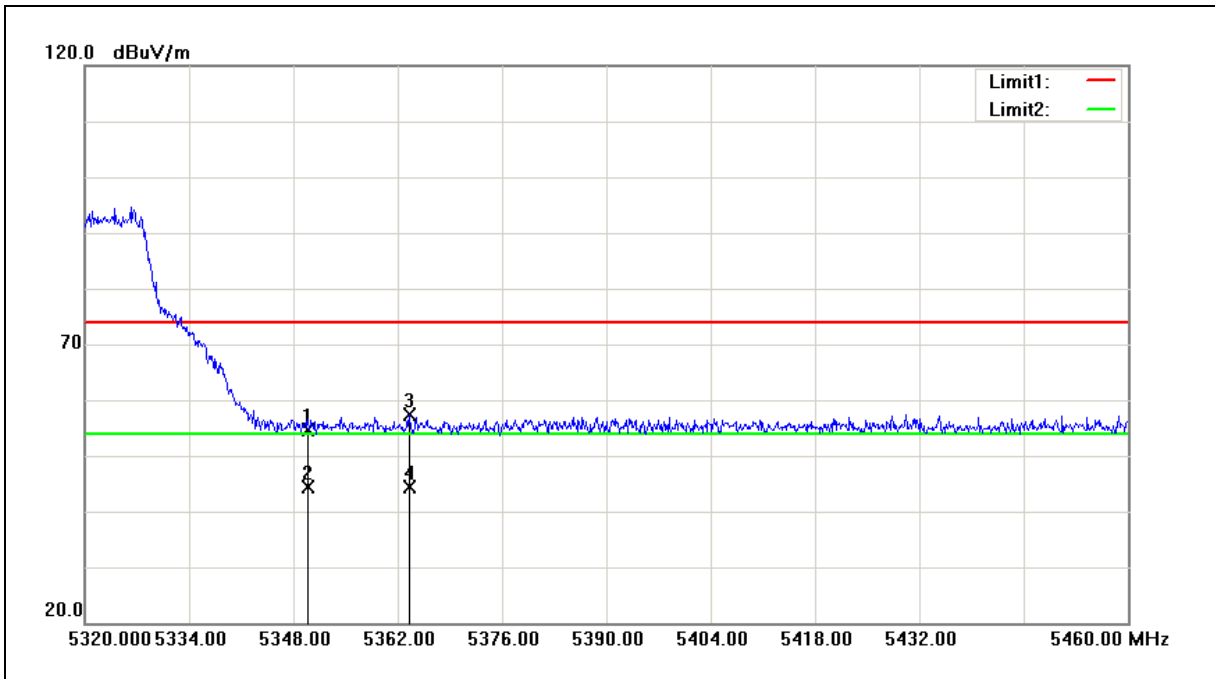

No.	Frequency (MHz)	Reading (dBuV)	Correct Factor (dB/m)	Result (dBuV/m)	Limit (dBuV/m)	Margin (dB)	Remark
1	5350.000	46.23	8.41	54.64	74.00	-19.36	peak
2	5350.000	35.98	8.41	44.39	54.00	-9.61	AVG
3	5363.540	48.90	8.43	57.33	74.00	-16.67	peak
4	5363.540	35.84	8.43	44.27	54.00	-9.73	AVG

- Note:1.Result (dBuV/m) = Correct Factor (dB/m) + Reading(dBuV).
- 2.Correction factor (dB/m) = Antenna Factor (dB/m) + Cable loss (dB) – Pre-Amplifier gain (dB).
3. When the peak results are less than average limit, so not need to evaluate the average.



Standard:	FCC Part 15.407	Test Distance:	3m
Test item:	Band edge	Power:	AC 120V/60Hz
Frequency:	5310MHz	Temp.(°C)/Hum.(%RH):	26(°C)/60%RH
Mode:	Mode 4	Date:	11/19/2016
Ant.Polar.:	Vertical		

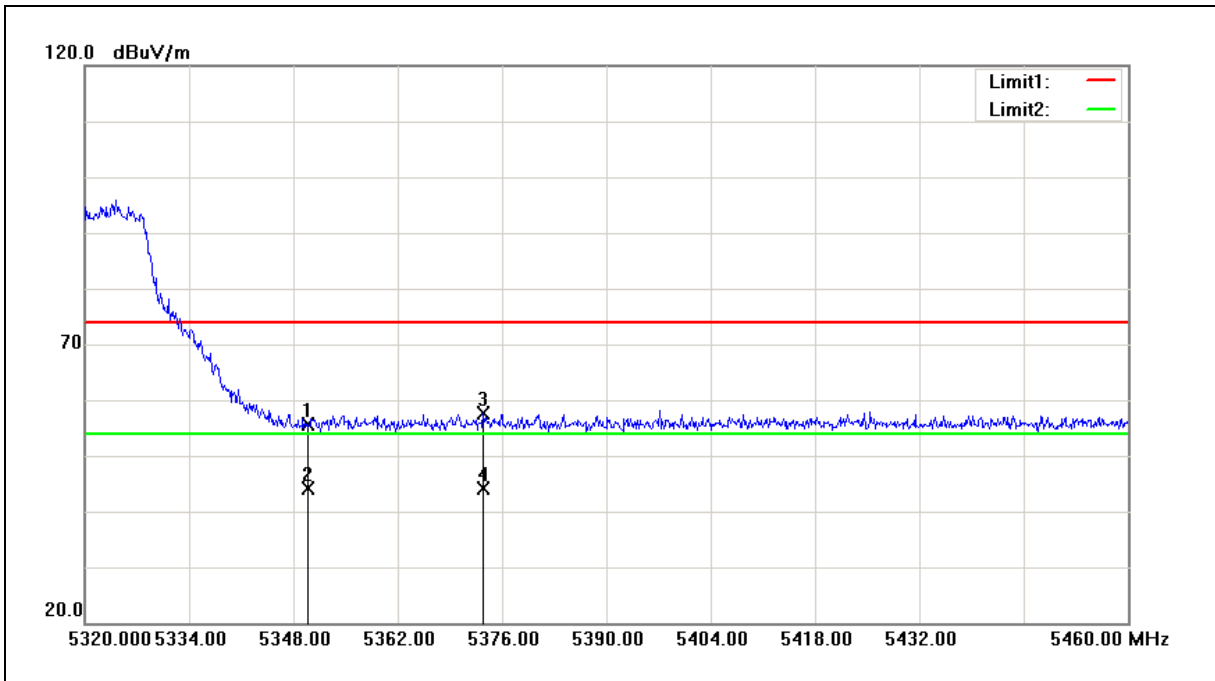

No.	Frequency (MHz)	Reading (dBuV)	Correct Factor (dB/m)	Result (dBuV/m)	Limit (dBuV/m)	Margin (dB)	Remark
1	5350.000	47.27	8.41	55.68	74.00	-18.32	peak
2	5350.000	35.83	8.41	44.24	54.00	-9.76	AVG
3	5373.480	49.17	8.43	57.60	74.00	-16.40	peak
4	5373.480	35.77	8.43	44.20	54.00	-9.80	AVG

Note:1.Result (dBuV/m) = Correct Factor (dB/m) + Reading(dBuV).

2.Correction factor (dB/m) = Antenna Factor (dB/m) + Cable loss (dB) – Pre-Amplifier gain (dB).

3. When the peak results are less than average limit, so not need to evaluate the average.



Standard:	FCC Part 15.407	Test Distance:	3m
Test item:	Band edge	Power:	AC 120V/60Hz
Frequency:	5290MHz	Temp.(°C)/Hum.(%RH):	26(°C)/60%RH
Mode:	Mode 5	Date:	11/19/2016
Ant.Polar.:	Horizontal		

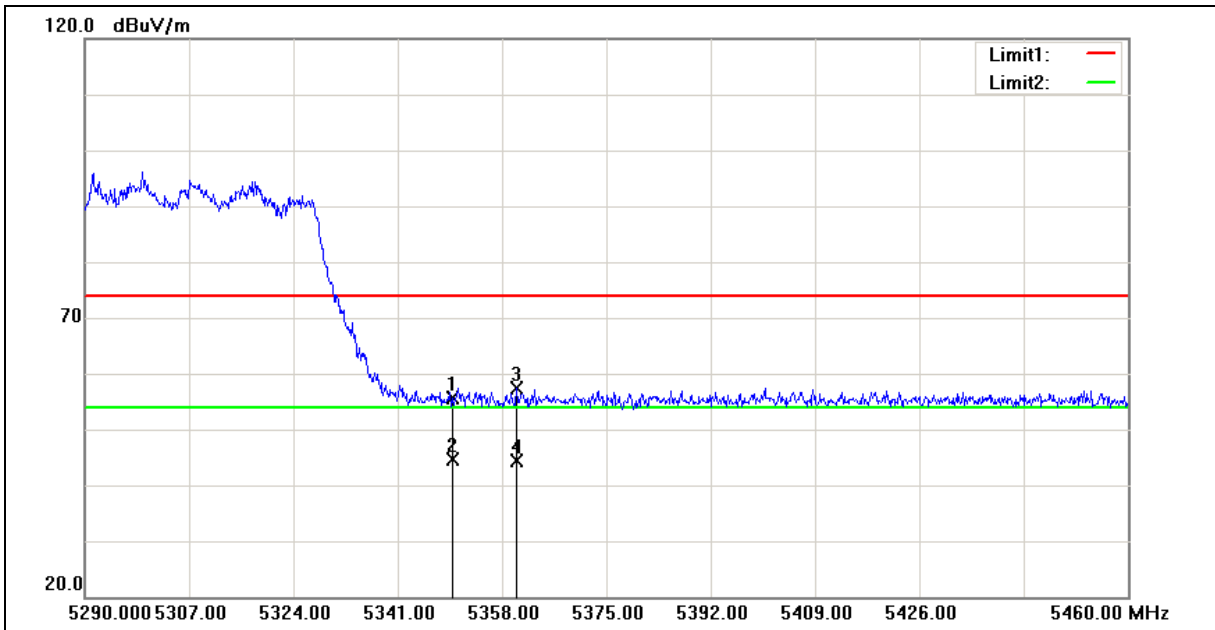

No.	Frequency (MHz)	Reading (dBuV)	Correct Factor (dB/m)	Result (dBuV/m)	Limit (dBuV/m)	Margin (dB)	Remark
1	5350.000	47.16	8.41	55.57	74.00	-18.43	peak
2	5350.000	36.26	8.41	44.67	54.00	-9.33	AVG
3	5360.380	48.89	8.42	57.31	74.00	-16.69	peak
4	5360.380	35.86	8.42	44.28	54.00	-9.72	AVG

- Note:1.Result (dBuV/m) = Correct Factor (dB/m) + Reading(dBuV).
- 2.Correction factor (dB/m) = Antenna Factor (dB/m) + Cable loss (dB) – Pre-Amplifier gain (dB).
3. When the peak results are less than average limit, so not need to evaluate the average.



Standard:	FCC Part 15.407	Test Distance:	3m
Test item:	Band edge	Power:	AC 120V/60Hz
Frequency:	5290MHz	Temp.(°C)/Hum.(%RH):	26(°C)/60%RH
Mode:	Mode 5	Date:	11/19/2016
Ant.Polar.:	Vertical		

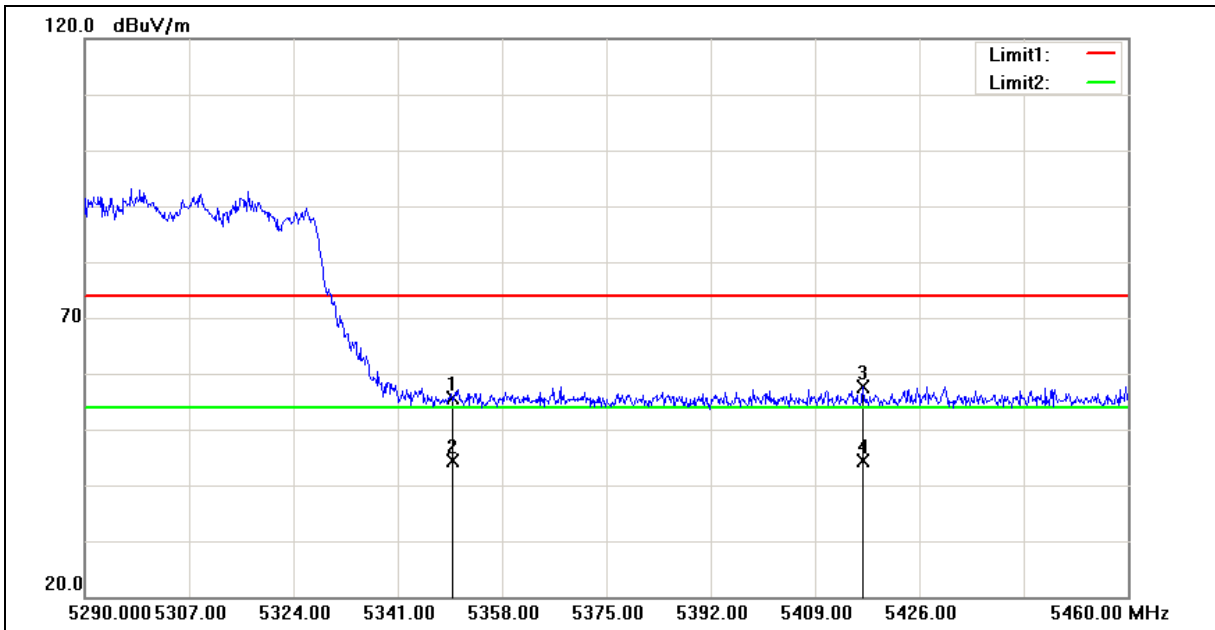

No.	Frequency (MHz)	Reading (dBuV)	Correct Factor (dB/m)	Result (dBuV/m)	Limit (dBuV/m)	Margin (dB)	Remark
1	5350.000	47.23	8.41	55.64	74.00	-18.36	peak
2	5350.000	35.97	8.41	44.38	54.00	-9.62	AVG
3	5416.820	49.19	8.48	57.67	74.00	-16.33	peak
4	5416.820	35.84	8.48	44.32	54.00	-9.68	AVG

- Note:1.Result (dBuV/m) = Correct Factor (dB/m) + Reading(dBuV).
- 2.Correction factor (dB/m) = Antenna Factor (dB/m) + Cable loss (dB) – Pre-Amplifier gain (dB).
3. When the peak results are less than average limit, so not need to evaluate the average.

4.3. Maximum Conducted Output Power and Transmit power control Measurement

■ **Limit**

Conducted Output Power

Frequency Range (MHz)	FCC Limit
5.250 ~ 5.350 GHz	The lesser of 250mW (24dBm) or 11dBm + 10log (B)

Note: Where B is the 26dB emission bandwidth in MHz.

According FCC KDB 662911 D01 v02r01 – for power measurements on IEEE802.11 devices,

Directional gain = GANT + 10 log(NANT/NSS) dBi

■ **Test Setup**

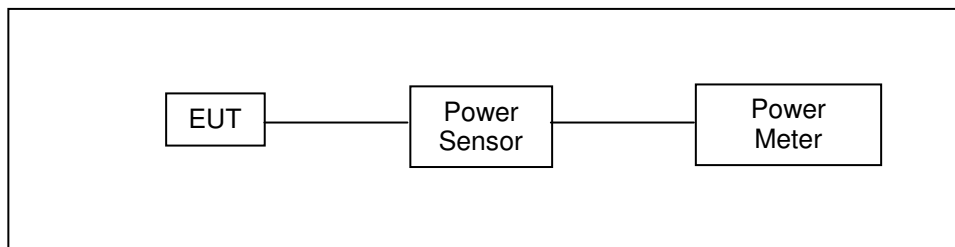

■ **Test Instruments**

Equipment	Manufacturer	Model Number	Serial Number	Cal. Date	Cal. Period
Power Sensor	Anritsu	MA2411B	1126022	08/29/2016	1 year
Power Meter	Anritsu	ML2495A	1135009	08/29/2016	1 year
Test Site	ATL	TE05	TE05	N.C.R.	-----

Note: N.C.R. = No Calibration Request.

■ **Test Procedure**

The test is performed in accordance with KDB789033: D02 General UNII Test Procedures New Rules v01r02, Guidelines for Compliance Testing of Unlicensed National Information Infrastructure (U-NII) Devices

Section (E) Maximum Conducted Output Power

3. Measurement using a Power Meter (PM)

b) Method PM-G (Measurement using a gated RF average power meter)



■ Test Result

Test Item		Maximum Conducted Output Power		
Test Mode		Mode 2: IEEE 802.11a Link Mode		
Date of Test		09/15/2016		
Frequency (MHz)	Data Rate (Mbps)	Max. Output Power		FCC Limit (dBm)
		(dBm)	(W)	
5260	6	14.24	0.027	≤ 24.00
5280		14.20	0.026	
5300		14.22	0.026	
5320		14.48	0.028	
5260	54	14.20	0.026	≤ 24.00
5280		14.14	0.026	
5300		14.16	0.026	
5320		14.44	0.028	

Test Item		Maximum Conducted Output Power		
Test Mode		Mode 3: IEEE 802.11n 5GHz 20MHz mode		
Date of Test		09/15/2016		
Frequency (MHz)	Data Rate (Mbps)	Max. Output Power		FCC Limit (dBm)
		(dBm)	(W)	
5260	6.5	14.18	0.026	≤ 24.00
5280		14.16	0.026	
5300		14.02	0.025	
5320		14.28	0.027	
5260	65	14.10	0.026	≤ 24.00
5280		14.14	0.026	
5300		14.00	0.025	
5320		14.25	0.027	

Test Item		Maximum Conducted Output Power		
Test Mode		Mode 4: IEEE 802.11n 5GHz 40MHz mode		
Date of Test		09/15/2016		
Frequency (MHz)	Data Rate (Mbps)	Max. Output Power		FCC Limit (dBm)
		(dBm)	(W)	
5270	13.5	13.79	0.024	≤ 24.00
5310		13.86	0.024	
5270	135	13.73	0.024	≤ 24.00
5310		13.78	0.024	

Test Item		Maximum Conducted Output Power		
Test Mode		Mode 5: IEEE 802.11ac 80MHz Link Mode		
Date of Test		09/15/2016		
Frequency (MHz)	Data Rate (Mbps)	Max. Output Power		FCC Limit (dBm)
		(dBm)	(W)	
5290	29.3	13.24	0.021	≤ 24.00
5290	390	13.17	0.021	≤ 24.00

4.4. 26dB RF Bandwidth Measurement

- **Limit**

N/A

- **Test Setup**

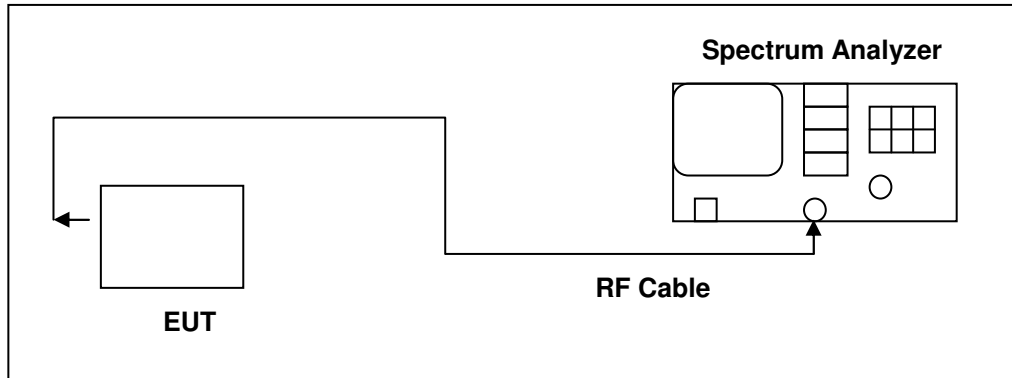

- **Test Instruments**

Equipment	Manufacturer	Model Number	Serial Number	Cal. Date	Cal. Period
Spectrum Analyzer	Agilent	E4445A	MY45300744	12/15/2015	1 year
Test Site	ATL	TE05	TE05	N.C.R.	-----

Note: N.C.R. = No Calibration Request.

- **Test Procedure**

The test is performed in accordance with KDB789033: D02 General UNII Test Procedures New Rules v01r02, Guidelines for Compliance Testing of Unlicensed National Information Infrastructure (U-NII) Devices - Part 15, Subpart E.

Spectrum Parameter	Setting
Attenuation	Auto
Span Frequency	>26dB Bandwidth
RBW	Approximately 1% of the emission bandwidth
VBW	VBW > RBW
Detector	Peak
Trace	Max Hold
Sweep Time	Auto



■ Test Result

Test Item	26dB RF Bandwidth	
Date of Test	11/22/2016	
Test Mode	Frequency (MHz)	26dB Bandwidth (MHz)
Mode 2	5260	23.110
	5280	24.710
	5320	24.880
Mode 3	5260	21.810
	5280	22.360
	5320	22.420
Mode 4	5270	42.590
	5310	42.420
Mode 5	5290	84.010



■ Test Graphs

Mode 2: IEEE 802.11a Link Mode	
5260	<p>Agilent Spectrum Analyzer - Occupied BW</p> <p>Center Freq: 5.26000000 GHz Trig: Free Run #Atten: 20 dB AvgHold: >10/10 Radio Std: None Radio Device: BTS</p> <p>Ref Offset 12 dB Ref 10.00 dBm</p> <p>Center 5.26 GHz #Res BW 300 kHz #VBW 1 MHz Span 25 MHz Sweep 1 ms</p> <p>Occupied Bandwidth 16.775 MHz Total Power 18.4 dBm Transmit Freq Error -69.272 kHz OBW Power 99.00 % x dB Bandwidth 23.11 MHz x dB -26.00 dB</p>
5280	<p>Agilent Spectrum Analyzer - Occupied BW</p> <p>Center Freq: 5.28000000 GHz Trig: Free Run #Atten: 20 dB AvgHold: >10/10 Radio Std: None Radio Device: BTS</p> <p>Ref Offset 12 dB Ref 10.00 dBm</p> <p>Center 5.28 GHz #Res BW 300 kHz #VBW 1 MHz Span 25 MHz Sweep 1 ms</p> <p>Occupied Bandwidth 16.831 MHz Total Power 19.0 dBm Transmit Freq Error -86.712 kHz OBW Power 99.00 % x dB Bandwidth 24.71 MHz x dB -26.00 dB</p>
5320	<p>Agilent Spectrum Analyzer - Occupied BW</p> <p>Center Freq: 5.32000000 GHz Trig: Free Run #Atten: 20 dB AvgHold: >10/10 Radio Std: None Radio Device: BTS</p> <p>Ref Offset 12 dB Ref 10.00 dBm</p> <p>Center 5.32 GHz #Res BW 300 kHz #VBW 1 MHz Span 25 MHz Sweep 1 ms</p> <p>Occupied Bandwidth 16.861 MHz Total Power 19.5 dBm Transmit Freq Error -75.651 kHz OBW Power 99.00 % x dB Bandwidth 24.88 MHz x dB -26.00 dB</p>



Mode 3: IEEE 802.11n 5GHz 20MHz mode	
5260	<p>Agilent Spectrum Analyzer - Occupied BW</p> <p>Center Freq: 5.260000000 GHz Trig: Free Run #Max: 20 dB</p> <p>Ref Offset: 12 dB Ref: 10.00 dBm</p> <p>Center 5.26 GHz #Res BW 300 kHz #VBW 1 MHz Span 25 MHz Sweep 1 ms</p> <p>Occupied Bandwidth: 17.844 MHz Total Power: 18.0 dBm Transmit Freq Error: -49.830 kHz OBW Power: 99.00 % x dB Bandwidth: 21.81 MHz x dB: -26.00 dB</p> <p>Frequency: Center Freq 5.260000000 GHz CF Step 2.500000 MHz Freq Offset 0 Hz</p>
5280	<p>Agilent Spectrum Analyzer - Occupied BW</p> <p>Center Freq: 5.280000000 GHz Trig: Free Run #Max: 20 dB</p> <p>Ref Offset: 12 dB Ref: 10.00 dBm</p> <p>Center 5.28 GHz #Res BW 300 kHz #VBW 1 MHz Span 25 MHz Sweep 1 ms</p> <p>Occupied Bandwidth: 17.854 MHz Total Power: 18.1 dBm Transmit Freq Error: -44.655 kHz OBW Power: 99.00 % x dB Bandwidth: 22.36 MHz x dB: -26.00 dB</p> <p>Frequency: Center Freq 5.280000000 GHz CF Step 2.500000 MHz Freq Offset 0 Hz</p>
5320	<p>Agilent Spectrum Analyzer - Occupied BW</p> <p>Center Freq: 5.320000000 GHz Trig: Free Run #Max: 20 dB</p> <p>Ref Offset: 12 dB Ref: 10.00 dBm</p> <p>Center 5.32 GHz #Res BW 300 kHz #VBW 1 MHz Span 25 MHz Sweep 1 ms</p> <p>Occupied Bandwidth: 17.880 MHz Total Power: 18.9 dBm Transmit Freq Error: -20.312 kHz OBW Power: 99.00 % x dB Bandwidth: 22.42 MHz x dB: -26.00 dB</p> <p>Frequency: Center Freq 5.320000000 GHz CF Step 2.500000 MHz Freq Offset 0 Hz</p>



Mode 4: IEEE 802.11n 5GHz 40MHz mode	
5270	<p>Agilent Spectrum Analyzer - Occupied BW</p> <p>Center Freq: 5.27000000 GHz Trig: Free Run #Atten: 20 dB AvgHold: >10/10 Radio Std: None Radio Device: BTS</p> <p>Ref Offset 12 dB Ref 10.00 dBm</p> <p>Center 5.27 GHz #Res BW 300 kHz #VBW 1 MHz Span 50 MHz Sweep 1 ms</p> <p>Occupied Bandwidth 36.319 MHz Total Power 18.2 dBm Transmit Freq Error 3.014 kHz OBW Power 99.00 % x dB Bandwidth 42.59 MHz x dB -26.00 dB</p> <p>Frequency Center Freq 5.27000000 GHz CF Step 5.000000 MHz Freq Offset 0 Hz</p>
5310	<p>Agilent Spectrum Analyzer - Occupied BW</p> <p>Center Freq: 5.31000000 GHz Trig: Free Run #Atten: 20 dB AvgHold: >10/10 Radio Std: None Radio Device: BTS</p> <p>Ref Offset 12 dB Ref 10.00 dBm</p> <p>Center 5.31 GHz #Res BW 300 kHz #VBW 1 MHz Span 50 MHz Sweep 1 ms</p> <p>Occupied Bandwidth 36.291 MHz Total Power 18.8 dBm Transmit Freq Error 11.952 kHz OBW Power 99.00 % x dB Bandwidth 42.42 MHz x dB -26.00 dB</p> <p>Frequency Center Freq 5.31000000 GHz CF Step 5.000000 MHz Freq Offset 0 Hz</p>

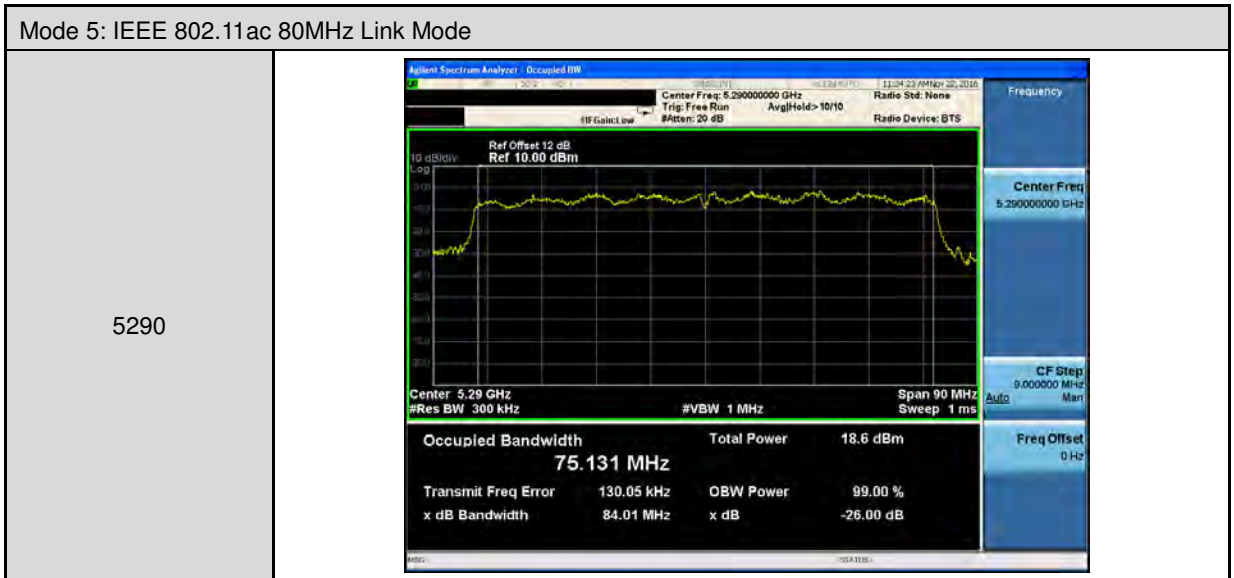

4.5. Peak Power Spectral Density Measurement

■ Limit

Conducted power spectral density

Frequency Range	FCC Limit
5.250 ~ 5.350 GHz	11 dBm/MHz

According FCC KDB 662911 D01 v02r01 – for power measurements on IEEE802.11 devices,

■ Test Setup

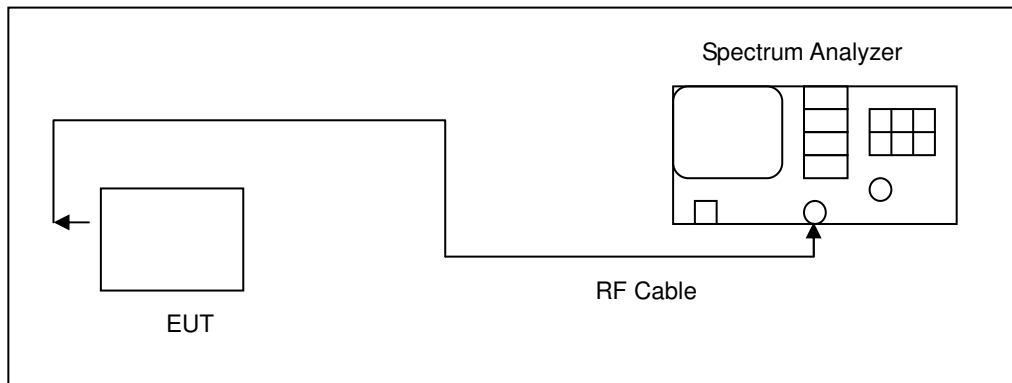

■ Test Instruments

Equipment	Manufacturer	Model Number	Serial Number	Cal. Date	Cal. Period
Spectrum Analyzer	Agilent	E4445A	MY45300744	12/15/2015	1 year
Test Site	ATL	TE05	TE05	N.C.R.	-----

Note: N.C.R. = No Calibration Request.



■ **Test Procedure**

The test is performed in accordance with KDB789033: D02 General UNII Test Procedures New Rules v01r02, Guidelines for Compliance Testing of Unlicensed National Information Infrastructure (U-NII) Devices - Part 15, Subpart E.

Spectrum Parameter	Setting
Attenuation	Auto
Span Frequency	Encompass the entire emissions bandwidth (EBW) of the signal
RBW	1 MHz (5725 ~ 5850MHz use 100 kHz)
VBW	3 MHz (5725 ~ 5850MHz use 300 kHz)
Detector	RMS
Trace	AVERAGE
Sweep Time	Auto
Trace Average	100 times
Note: If measurement bandwidth of Maximum PSD is specified in 500 kHz, add $10\log(500\text{kHz}/100\text{kHz})$ to the measured result.	

■ **Test Result**

Test Item	Conducted power spectral density				
Date of Test	11/22/2016				
Test Mode	Frequency (MHz)	Measurement (dBm/MHz)	Duty Factor (dB)	Calculated (dBm/MHz)	Limit (dBm/MHz)
Mode 2	5260	7.962	0	7.962	≤ 11.00
	5280	7.964	0	7.964	
	5320	6.757	0	6.757	
Mode 3	5260	5.236	0	5.236	
	5280	5.588	0	5.588	
	5320	5.902	0	5.902	
Mode 4	5270	3.453	0	3.453	
	5310	4.153	0	4.153	
Mode 5	5290	2.110	0	2.110	

Note: Method SA-2, Power density = measured result + $10\log(1/\text{duty cycle})$ + Conversion ratio = measured result + duty factor.



■ Test Graphs

Mode 2: IEEE 802.11a Link Mode	
5260	
5280	
5320	



Mode 3: IEEE 802.11n 5GHz 20MHz mode	
5260	
5280	
5320	



Mode 4: IEEE 802.11n 5GHz 40MHz mode	
5270	 <p>Agilent Spectrum Analyzer - Swept 54</p> <p>Ref Offset 12 dB Ref 22.00 dBm</p> <p>Mkr1 5.267 84 GHz 3.453 dBm</p> <p>Center 5.27000 GHz #Res BW 1.0 MHz #VBW 3.0 MHz* Sweep 1.000 ms (1001 pts)</p> <p>Span 60.00 MHz</p> <p>Frequency: Auto Tune Center Freq: 5.270000000 GHz Start Freq: 5.240000000 GHz Stop Freq: 5.300000000 GHz CF Step: 6.000000 MHz Freq Offset: 0 Hz</p>
5310	 <p>Agilent Spectrum Analyzer - Swept 54</p> <p>Ref Offset 12 dB Ref 22.00 dBm</p> <p>Mkr1 5.324 40 GHz 4.153 dBm</p> <p>Center 5.31000 GHz #Res BW 1.0 MHz #VBW 3.0 MHz* Sweep 1.000 ms (1001 pts)</p> <p>Span 60.00 MHz</p> <p>Frequency: Auto Tune Center Freq: 5.310000000 GHz Start Freq: 5.280000000 GHz Stop Freq: 5.340000000 GHz CF Step: 6.000000 MHz Freq Offset: 0 Hz</p>

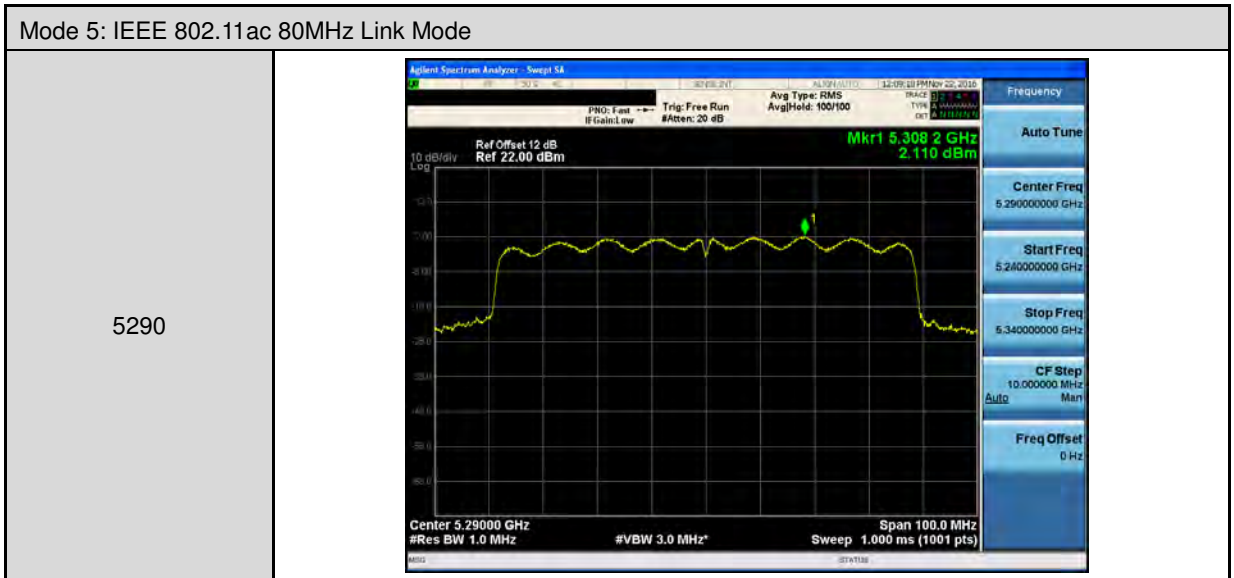

4.6. Frequency Stability Measurement

■ Limit

Manufacturers of U-NII devices are responsible for ensuring frequency stability such that an emission is maintained within the band of operation under all conditions of normal operation as specified in the users manual.

■ Test Setup

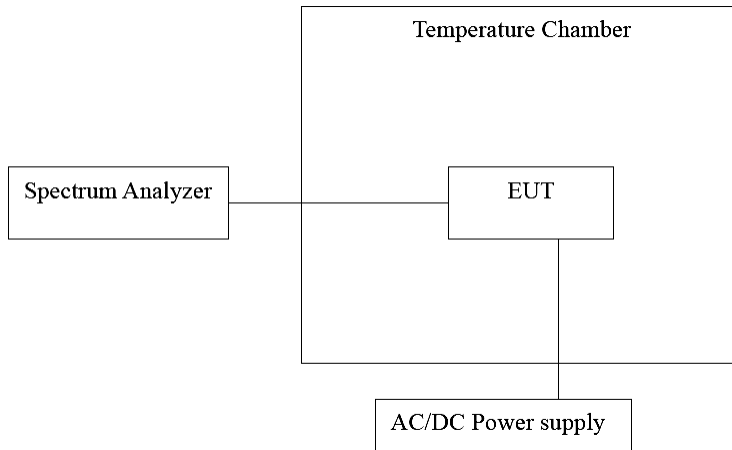

■ Test Instruments

Equipment	Manufacturer	Model Number	Serial Number	Cal. Date	Cal. Period
Spectrum Analyzer	Agilent	E4408B	MY45107753	08/08/2016	1 year
Temperature & Humidity Chamber	TAICHY	MHU-225LA	980729	04/18/2016	1 year
Test Site	ATL	TE05	TE05	N.C.R.	-----

Note: N.C.R. = No Calibration Request.

4.7. Test Procedure

1. The EUT was placed inside the environmental test chamber and powered by nominal AC/DC voltage.
2. Turn the EUT on and couple its output to a spectrum analyzer.
3. Turn the EUT off and set the chamber to the highest temperature specified.
4. Allow sufficient time (approximately 30 min) for the temperature of the chamber to stabilize.
5. Repeat step 2 and 3 with the temperature chamber set to the lowest temperature.
6. The test chamber was allowed to stabilize at +20 degree C for a minimum of 30 minutes. The supply voltage was then adjusted on the EUT from 85% to 115% and the frequency record.



■ Test Result

Temperature Variations

Test Item	Frequency Stability					
Date of Test	09/30/2016					
Frequency	Temp. (°C)	Voltage (Vac)	Measured Freq. (MHz)	Delta Freq. (Hz)	Tolerance (ppm)	Result (Pass/Fail)
5280 MHz	0	120	5279.9631	-36900	-6.989	Pass
	10		5279.9713	-28700	-5.436	Pass
	20		5279.9570	-43000	-8.144	Pass
	30		5279.9522	-47800	-9.053	Pass
	40		5279.9479	-52100	-9.867	Pass

Voltage Variations

Test Item	Frequency Stability					
Date of Test	09/15/2016					
Frequency	Temp. (°C)	Voltage (Vac)	Measured Freq. (MHz)	Delta Freq. (Hz)	Tolerance (ppm)	Result (Pass/Fail)
5280 MHz	20	138.00	5279.9709	-29100	-5.511	Pass
		120.00	5279.9570	-43000	-8.144	Pass
		102.00	5279.9397	-60300	-11.420	Pass

Note: The manufacturer's frequency stability specification is better than 20ppm.



4.8. Antenna Requirement

■ Requirement

For intentional device, according to 15.203, an intentional radiator shall be designed to ensure that no antenna other than that furnished by the responsible party shall be used with the device.

And According to 15.407 (a), if transmitting antennas of directional gain greater than 6 dBi are used, the power shall be reduced by the amount in dB that the directional gain of the antenna exceeds 6dBi.

■ Antenna Connector Construction

See section 2 – antenna information.