**VEGA BT C1/C2 Linear Barcode Scanner with Bluetooth
V-1010BT**



EMEA

SCANTECH-ID BV

Nijverheidsweg Noord 60-34

3812 PM Amersfoort

The Netherlands

Tel:+31-33-4698400

Fax:+31-33-4650615

E-mail:info@scantech-id.com

www.scantech-id.com

HEAD QUARTER

CHAMPTEK INCORPORATED

5/F, No.2 Alley 2, Shin-Wei Lane,

Chung Cheng Rd., Hsin Tien City 231,

Taipei, Taiwan

Tel:+886-2-2219-2385

Fax:+886-2-2219-2387

E-mail:sales@champtek.com

www.champtek.com

China

CHAMPTEK INCORPORATED

#901, No. 39, Wuzhong Rd., Shanghai

200235, China

Tel: +86-21-5489-0021

Fax: +86-21-5489-1833

Notice The manufacturer shall not be liable for technical or editorial errors or omissions contained herein; nor for incidental or consequential damages in connection with the furnishing, performance or use of the publication



User's Installation and Configuration Manual

Scantech-ID VEGA

Copyright © 2009, Scantech-ID BV.

This manual is copyrighted, with all rights reserved. Under the copyright laws, this manual may not, in whole or in part, be copied, photocopied, reproduced, translated or converted to any electronic medium or machine readable form without prior written consent of Scantech-ID BV.

Limited Warranty

Under all circumstances this manual should be read attentively, before installing and/or using the product. In no event shall Scantech-ID BV be liable for any direct, indirect, special, consequential or incidental damages arising out of the use or inability to use this documentation or product, even if advised of the possibility of such damages. In particular, Scantech-ID BV shall not be liable for any hardware, software, or data that is stored or used with the product, including the cost of repairing, replacing or recovering the above. Scantech-ID BV reserves the right to change parts of the device at any time without preceding or direct announcement to the client.

Scantech-ID BV reserves the right to revise this manual, and to make changes in the contents without obligation to notify any person or entity of the revision or change. A serial number appears on the product. Make sure that this official registration number has not been removed. It should be used whenever servicing by Scantech-ID BV or an authorized Scantech dealer is necessary.

Table of contents

Table of contents	1
Introduction	4
Chapter 1 Product Safety	5
1.1 Safety & Caution	6
1.2 FCC Warning	7
1.3 Scanner Labelling	8
Chapter 2 General Description	9
2.1 Use of the VEGA.....	10
Chapter 3 Installation of the VEGA V-1010.....	11
3.1 Unpacking	12
3.2 Mounting	13
Chapter 4 Installation of the VEGA V-1010BT	15
4.1 Unpacking	16
4.2 Cradle Installation.....	17
4.3 Set up Bluetooth Communication	18
Chapter 5 Cover Display	21
5.1 Setup Cover Display	22

Chapter 6	Configuring the VEGA	27
6.1	Preface	28
6.2	Factory Default Setting	31
Chapter 7	Programming Codes	33
7.1	General Process	34
7.2	Interface Selection	36
7.3	Bluetooth Scanner Setup	37
7.4	Bluetooth Cradle Setup	40
7.5	Scanner Operation	42
7.6	RS232 mode parameters	45
7.7	Keyboard Wedge mode parameters	48
7.8	Output Characters	52
7.9	Code Type	53
7.10	UPC/EAN/JAN Parameters	57
7.11	Code 39 Parameters.....	59
7.12	Code 128 Parameters.....	62
7.13	Interleaved 2 of 5 Parameters.....	64
7.14	Industrial 2 of 5 Parameters	67
7.15	Matrix 2 of 5 Parameters.....	69
7.16	CODABAR Parameters.....	71
7.17	Code 93 Parameters.....	74
7.18	Code 11 Parameters.....	76
7.19	MSI/plessey Code Parameters.....	78
7.20	Telepen Parameters	80

7.21	GS1 databar Parameters	82
7.22	GS1 databar Limited Parameters.....	83
7.23	GS1 Databar Expanded Parameters.....	84
Chapter 8	Miscellaneous Parameters	85
8.1	Bar Code ID	86
8.2	Preambles and Postambles Insertion.....	89
8.3	Character Deletion.....	93
Appendices	97
D	Readable Symbologies.....	105
E	Technical Specifications	106
F	Scan Map	108
G	Led Indicator Status.....	110
H	Test Symbologies.....	111
I	Overview Partnumbers.....	114
J	Quick Configuration.....	115

Introduction

VEGA is a cutting-edge gun-type barcode scanner which is designed specifically for retail market. To the brand new series of **VEGA**, we add on more user-friendly functions with detachable cable that makes it more easily to be operated by the customers.

Speaking of the performance, this scanner supports middle to long range mode. For specification of **VEGA** which supports the reading depth up to 27 centimeters , scan rate is up to 700 scans / per second.

The new **VEGA** scanner has most modern design with the decorative cover display on the top of the scanner that will enhance the looks of the checkout counter in the retail market. This magnificent design allowed end-users to display their product information or any relevant commercial message in the cover display. This advanced mechanical design truly creates a win-win solution for both POS retail systems and consumers.

In short, **VEGA** is absolutely a high performance gun-type scanner, which provides the customer with the most cost-effective solution in the market. It is perfectly suitable and definitely the best choice for any retailers using POS environment.

Quality and Durability

The **VEGA** comes with the same top quality as all other Scantech-ID products. So at a very competitive price the same quality and performance of more expensive products is available. Due to the high MTBF times of every component a long and service free operation time is secured.

Connectivity

The **VEGA** is available into interface types, RS232 interface, KBW, USB interface and also with Bluetooth technology, so there is always a solution to connect the Vega to your POS system.

1.1 SAFETY & CAUTION

1. Please read the following safety statement carefully.
2. Please preserve this user manual for reference sometime.
3. Before cleaning the **VEGA**, the users must cut off all AC power. Do not use liquid or spray type of detergent to clean the **VEGA**. Please use dampish cotton cloth to clean the **VEGA**.
4. The outlet must set nearby the **VEGA** for connecting power easily.
5. Keep the **VEGA** dry to avoid short circuit.
6. During installation you must fix the equipment at solid table to avoid damage caused by falling.
7. Before inserting power please ensure the voltage is healthy to the equipment.
8. For safety please tie wire well and don't put anything on the wire.
9. If you don't use this equipment for long time, please cut off the power to avoid damage from surge power.
10. Don't spray any liquid on this scanner because it may cause a fire or short circuit.
11. Please do not open the equipment. For safety only the qualified serviceman can open the equipment.
12. If there are the following situations please contact with the qualified serviceman to check this equipment.
 - (a) The damage of wire or pin of power supply.
 - (b) Some Liquid infiltrate into the equipment.
 - (c) The equipment has been exposed to wet environment.
 - (d) The equipment can't work well.
 - (e) The equipment has any obvious damage, making the **VEGA** working abnormally.
13. Don't storage the **VEGA** at the temperature lower than -20°C (-4°F) or higher than +70°C (158°F) to avoid any damage.

1.2 FCC WARNING

This equipment complies with the requirements in Part 15 of FCC.

Any operation must comply with the conditions below:

- (a) The equipment will not cause any severe interference.
- (b) The equipment can avoid any interference from environment.



This equipment has been tested and found to comply with the limits for a Class B digital device, pursuant to part 15 of the FCC rules. These limits are designed to provide reasonable protection against harmful interference in a residential installation. This equipment generates, uses and can radiate radio frequency energy and, if not installed and used in accordance with the instructions, may cause harmful interference to radio communications. However, there is no guarantee that interference will not occur in a particular installation. If this equipment does cause harmful interference to radio or television reception, which can be determined by turning the equipment off and on, the user is encouraged to try to correct the interference by one or more of the following measures:

- Reorient or relocate the receiving antenna.
- Increase the separation between the equipment and receiver.
- Connect the equipment into an outlet on a circuit different from that to which the receiver is connected.
- Consult the dealer or an experienced radio/TV technician for help.

You are cautioned that changes or modifications not expressly approved by the party responsible for compliance could void your authority to operate the equipment.

FCC RF Radiation Exposure Statement:

1. This Transmitter must not be co-located or operating in conjunction with any other antenna or transmitter.
2. This equipment complies with FCC RF radiation exposure limits set forth for an uncontrolled environment.

This device complies with Part 15 of the FCC Rules. Operation is subject to the following two conditions: (1) this device may not cause harmful interference and (2) this device must accept any interference received, including interference that may cause undesired operation.

□

1.3 SCANNER LABELLING

One label is present on the housing of the **VEGA** as indicated in the figure below. This label is attached by the manufacturer and should not be removed. The scanner serial number is found on this label. This official registration is strictly related to the device. The supplier may ask for this number when the scanner needs servicing.

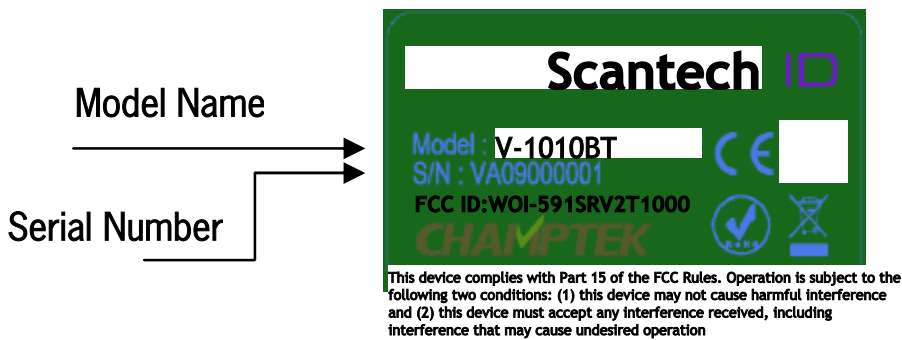

Model Name :
V-1010BT

Serial Number: Product Serial No. (VA.....)

See Appendix I for more information in detail.

Chapter 2 General Description

2.1 USE OF THE VEGA

The **VEGA** is very ergonomic and modern designed and very user friendly. It can be connected to your POS or Host system through a RS232 cable, KBW cable, USB cable or with Bluetooth wireless.

To read a bar code, you simply press the red trigger button and aim the beam to the bar code. but you need to position the beam so that it falls across all bars in the 1D barcodes. You will hear one beep and the green LED indicator will light on after scan successfully.

The programming of the **VEGA** is very easy, you can set-up the **VEGA** by scan all necessary programming codes one time that meet applications, the settings are directly saved permanently, and all settings can be disabled after scan reset factory default.

Thanks to the power full decoding processor, the **VEGA** can decode all major 1D codes.

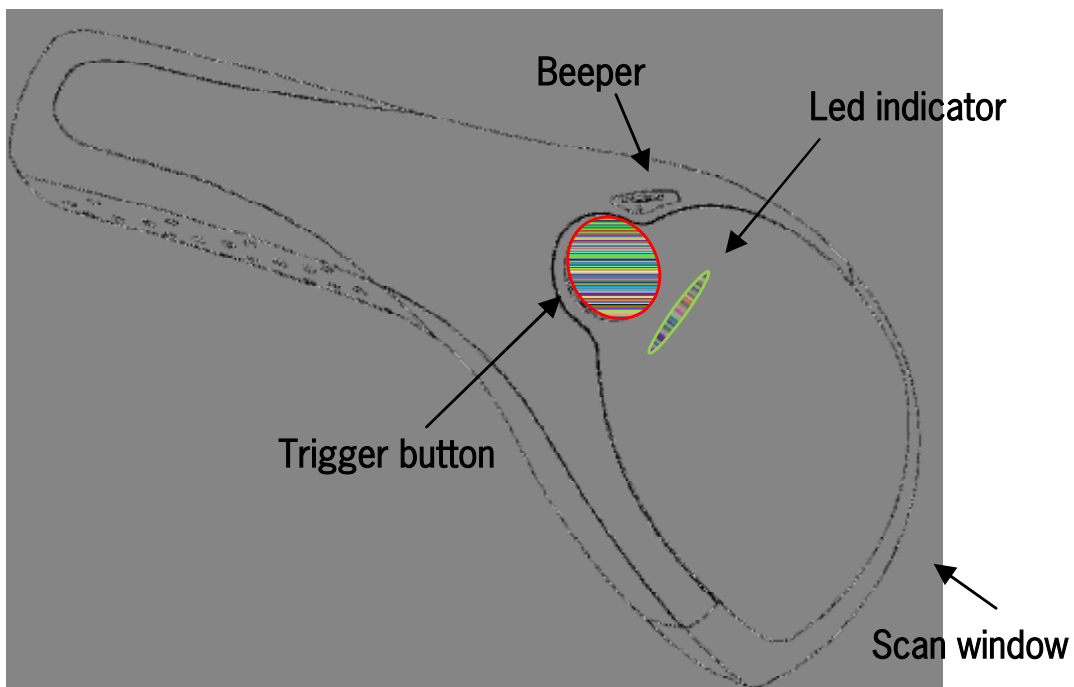

Chapter 3 Installation of the VEGA V-1010

3.1 UNPACKING

Unpack the **VEGA** as follows:

1. Take the **VEGA** and its accessories out of the box.
2. Remove the packing material.
3. Check the packing list to make sure you have received all of the items ordered.

Standard Shipment Package

- a. **VEGA** Linear Imager handheld bar code scanner
 - b. Power Supply (if applicable)
 - c. Quick Start Guide
 - d. Communication Cable
 - e. Stand
 - f. Transparent Cover Plate
4. Visually inspect the **VEGA** and accessories for any evidence of physical damage.
 5. If anything is missing or appears to be damaged, immediately contact your dealer.

ATTENTION

Store the packing material and boxes: it should be used whenever the **VEGA** is transported for servicing.

3.2 MOUNTING

Once you have unpacked all components, you can start installing the **VEGA**. Installing the **VEGA** is divided in different steps:

1. Connect the **VEGA** to the supplied communication cable (RJ45 side).
2. Connect the **VEGA** communication cable to the POS or Host system.
3. Connect the Power supply (if applicable) to Power cable inlet.
4. Plug the power supply into the AC outlet.

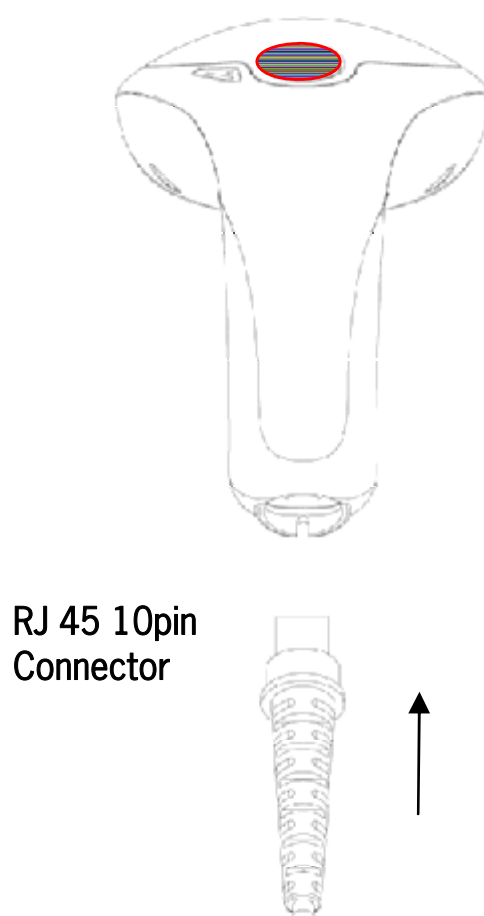

Chapter 4 Installation of the VEGA V-1010BT

4.1 UNPACKING

Unpack the **VEGA** as follows:

1. Take the **VEGA** and its accessories out of the box.
2. Remove the packing material.
3. Check the packing list to make sure you have received all of the items ordered.

Standard Shipment Package

- a. **VEGA** Linear Imager Handheld Bar code Scanner Bluetooth
 - b. Communication Cable (RS-232, KBW or USB)
 - c. Power Supply
 - d. Quick Start Guide
 - e. Bluetooth Cradle or charger
 - f. Transparent Cover Plate
4. Visually inspect the **VEGA** and accessories for any evidence of physical damage.
 5. If anything is missing or appears to be damaged, immediately contact your dealer.

ATTENTION

Store the packing material and boxes: it should be used whenever the **VEGA** is transported for servicing.

4.2 CRADLE INSTALLATION

To set up your **VEGA** scanner with Bluetooth technology, please follow the next steps.

1. Connect the supplied communication cable at the bottom side of the cradle.
2. Connect the other side of the communication cable to the right connector of your POS or HOST system.
3. Plug the external power supply into the power jack on the bottom of the cradle.
4. Plug the power supply into the AC outlet.
5. Turn on your POS or HOST system.
6. Set up communication between the **VEGA** scanner and cradle.
To set up communication between **VEGA** scanner and cradle, see chapter 4.3 Set up Bluetooth Communication.

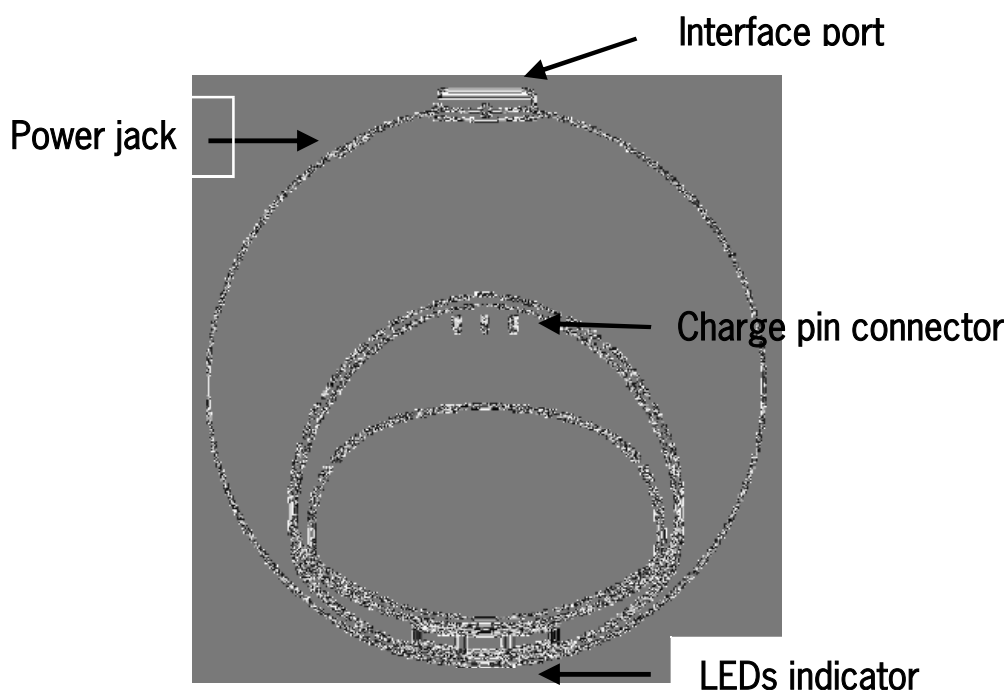

4.3 SET UP BLUETOOTH COMMUNICATION

Before the **VEGA** scanner can be used for normal operation, Bluetooth communication must be set up between the **VEGA** scanner and cradle, Scanner client mode or to a Bluetooth application device, Scanner Server mode.

4.3.1 Pairing

Pairing refers to when a **VEGA** scanner has been linked or paired to a specific cradle by scanning that cradle's Bluetooth MAC address code, this Bluetooth MAC address code is unique for each cradle. This address code is located on the bottom side of the cradle. The pairing of a **VEGA** scanner to a cradle is one to one. Only one **VEGA** scanner can be paired to a cradle at any point in time.

4.3.2 Set up Client Mode Communication

To set-up the communication between the **VEGA** scanner and the cradle follow the next steps:

1. The **VEGA** scanner must scan "Scanner Client Mode ON/Scanner Server mode Off" barcode . To set the **VEGA** scanner in client mode.
2. Scan the Bluetooth MAC address code located on the bottom of the cradle.
3. When the Bluetooth MAC was successfully scanned, scanner will initiate with short beep sounds. Blue and red led will also blink followed by a long beep sound. Blue led will turn off to finish the set up.
4. Wait approximately five seconds, for completing the connection process.
5. If successful, the blue led on the cradle will be on.
6. If the connections failed the scanner indicates with shot beep sounds and the cradle with blinking blue led.

ATTENTION

The **VEGA** scanner must be charged for a minimum of 8 hours before the scanner can be placed in full operation for the first time. The cradle red led will indicate in red when the scanner is charged. After the battery is full, the red light will be off. If the battery power of the **VEGA** is too low, the **VEGA** will indicate this with red led and beeper warning.

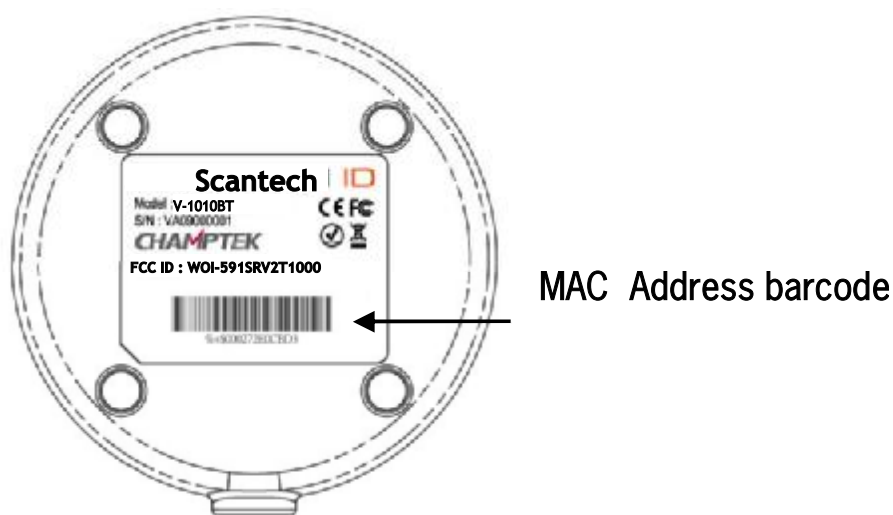

It is important to know that the **VEGA** scanner will only communicate with the cradle whose unique Bluetooth MAC address was the last address scanned. If a cradle is paired with the **VEGA** scanner, another **VEGA** scanner can't be paired with that cradle until the original connection is broken.

If you pair a second **VEGA** scanner to an in use cradle, the cradle's connection to the first **VEGA** scanner will be broken and the connection re-established with the second **VEGA** scanner.

4.3.3 Set up Server Mode Communication

To set-up the communication between the VEGA scanner and Bluetooth application device follow the next steps.

1. The VEGA scanner must scan “Scanner Server Mode ON/Scanner Client Mode Off” barcode , to set the VEGA scanner in server mode.
2. When control the Bluetooth device to search the scanner, enter pin code (default 00:00:00:00) to setup comport.
3. When VEGA scanner is successful connected, scanner will initiate with short beep sounds. Blue and red led will also blink followed by a long beep sound. Blue led will turn off to finish the set up.

4.3.4 Sleep mode

The **VEGA** scanner is equipped with sleep mode function to save battery energy, when the **VEGA** scanner is not used for a specified time. During sleep mode all the functions and connection will be halted, After press the red trigger button the scanner can be wake up and reconnect the communication with the cradle. The waiting time to go into sleep mode can be set into 1 minute or 10 minutes, by scanning the according programming code, see chapter 7.

4.3.5 Memory mode

This memory mode function is enabled when the Bluetooth connection fail and you have scanned data. This data is stored in the memory of the **VEGA** scanner. When scan barcode “memory read” stored data will be immediately transmit to the cradle after reconnection, when scan barcode “memory clear” all stored memory data will be erased.

The capacity of this memory depends on the scanned data size, approximately 50 sets of data.

This function is not operational when there is successful Bluetooth connection.

Chapter 5 Cover Display

5.1 SETUP COVER DISPLAY

The **VEGA** scanner has the possibility to change the decorative cover display on the top of the scanner into a display that can show your own commercial message.

5.1.1 Message format

Create your own commercial message with the following outline format, use thicker paper

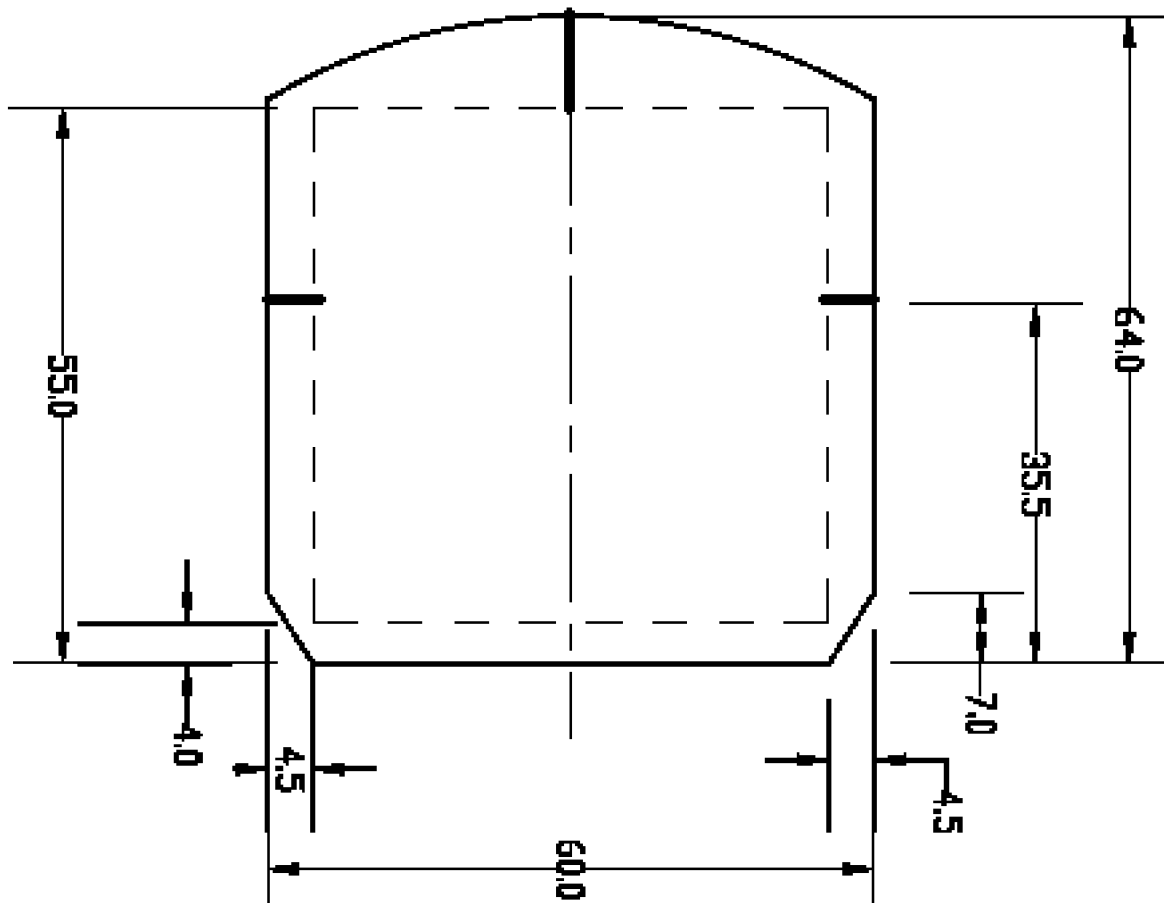

5.1.2 Change Cover Display

Follow the next instruction steps to change the black Cover Display into the transparent Cover Display, so that your customers can read your own commercial message.

<p>Step 1: Press out the front rubber lid toward the arrow</p>	 A close-up photograph of the front rubber lid of the scanner. A black arrow points downwards from the center of the lid, indicating the direction to press it out.
<p>Step 2: Pull out the front rubber lid off the main unit</p>	 A photograph showing the front rubber lid being pulled away from the main unit. A black arrow points upwards from the bottom of the lid, indicating the direction to pull it out.
<p>Step 3: Press out top cover rim from the inner lock</p>	 A photograph showing the top cover rim being pressed out from the inner lock. A black arrow points to the right, indicating the direction to press the rim out. The text "SCANTECH ID" is visible on the black cover.

Step 4:

Press out the other side of inner lock and remove the complete cover

**Step 5**

Assemble transparent top cover rim into inner lock.

**Step 6**

Assemble another side transparent top cover rim into the inner lock



Step 7

Insert your commercial message card into the top cover toward the arrow.



Step 8

Assemble the front rubber lid into the main unit toward the arrow.



Step 9

Complete change top cover.



Chapter 6 Configuring the VEGA

6.1 PREFACE

How to configure the **VEGA**:

The Barcode programming feature gives the possibility to change the **VEGA** scanner settings with use programming labels.

6.1.1 Changing Scanner Settings with programming codes

You can set-up your **VEGA** by scan all necessary programming codes for parameters that meet applications.

In order to change the scanner settings please follow the sequence below:

1. Power-up the scanner.
2. Open the scanner programming mode by scanning Start Configuration.
3. Change scanner settings by scanning any of the programming code that meet applications.
4. Close the scanner programming mode by scanning End Configuration.
5. Save configuration by scanning Save Parameters

An Example:

For changing the Baudrate to 38400 the following codes must be scanned successively:

Start configuration -> Baudrate 38400 -> End configuration -> Save Parameters

After reading a valid programming code the scanner will give a double High beep and the green led indicator will lights on.

By scanning "Set All Default" label, the settings will go back to the factory default settings.

6.1.2 Programming flow chart

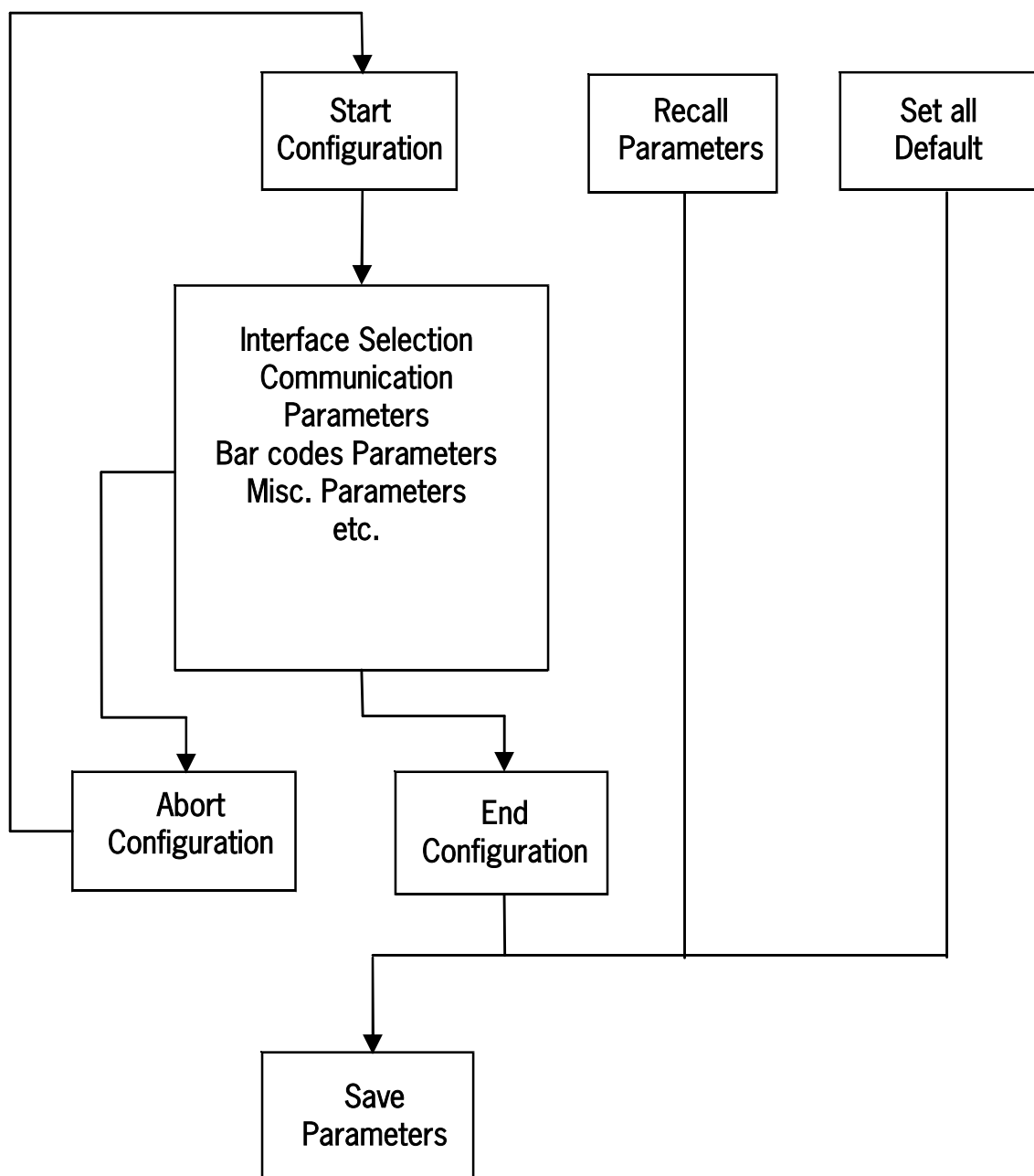

6.1.3 Changing Scanner Settings with Utility Tool

Scantech-ID has setup this user manual with the most common used programming codes, it could be possible that you need more advanced settings to use the **VEGA** without any problems into your application.

In this case you can set-up your **VEGA** by using the advanced Utility Tool. This tool can be used with the following operation systems: Windows98, Windows2000, Windows XP en Windows Vista.

This Utility Tool can be delivered on request. Please contact Scantech-ID Technical Support Department.

6.2 FACTORY DEFAULT SETTING

The **VEGA** is set default with the following settings:

RS232 COMMUNICATION	DEFAULT
Baudrate	9600
Parity	None
Data bits	8
Stop bits	1
RTS/CTS	Off
Postamble	<CR+LF>
DECODER SELECTION	DEFAULT
All UPC/EAN/JAN	On
Code 11	Off
Code 39	On
Code 39 Full ASCII	Off
Code 32 / Italian Pharmacy	Off
Code 128	On
Codabar	On
GS1 Databar	Off
GS1 Databar Expanded	Off
GS1 Databar Limited	Off
Interleaved 2 of 5	On
Industrial 2 of 5	Off
Matrix 2 of 5	Off
MSI / Plessey	Off
Telepen	Off
China Postage	Off
CODE IDENTIFIERS	DEFAULT
Code identifiers	Off

The factory defaults settings are shown with <> and bold in the following chapters.

Chapter 7 Programming Codes

7.1 GENERAL PROCESS

1 Power up the scanner

2 Scan the Start of Configuration bar code



3 Scan the bar code for the desired feature –
You can scan all features before scanning End of
Configuration.

4 Scan End of Configuration bar code



5 Scan Save Parameters bar code



7.1.1 Abort Configuration

Scan Abort configuration



7.1.2 Recall

Replace the current parameters
by the parameters saved last time

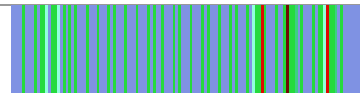

7.1.3 Set All Default

Scan Set all Default bar code



7.1.4 Version information

Display the decoder version information and date code.

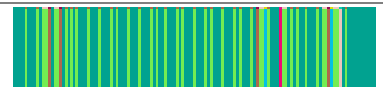

7.2 INTERFACE SELECTION

7.2.1 Interface

<Keyboard Mode>



RS232 Mode



USB Mode



7.3 BLUETOOTH SCANNER SETUP

7.3.1 Preface

How to configure the Bluetooth function:

The Barcode programming feature gives the possibility to change the **VEGA** scanner settings with use programming labels.

7.3.2 Changing Scanner Settings with programming codes

You can set-up Bluetooth function by direct scan all necessary programming codes for Bluetooth parameters.

After reading a valid programming code the scanner will give a High-low beep and the Blue-Red led indicator will lights on.

By scanning "Set All Default" label, the settings will go back to the factory default settings.

7.3.3 Bluetooth Default Setting

Default Setting
(Memory Mode OFF, Sleep Mode ON,
Sleep Mode Time 1 min)



7.3.4 Scanner Mode

Client Mode ON / Server Mode OFF



Server Mode ON / Client Mode OFF



7.3.5 Memory Mode

Memory Mode ON



Memory Mode <OFF>



Memory Read



Memory Clear



7.3.6 Sleep Mode

Sleep Mode <ON>
1 minute



10 minutes





Sleep Mode OFF



7.3.7 Scanner Pincode Mode

Default Security code (PINCODE=000000)	
Security Code ON	
Security Code OFF	

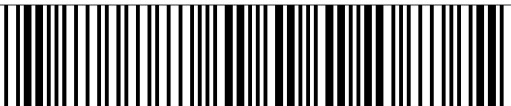
7.3.8 Scanner Pincode Setup

Set PINCODE Max 6 digits, 0-9 and A-Z ASCII code	
Go to ASCII table in Appendix B, scan 6 labels that represents the PINCODE	
Complete to Set PINCODE	

7.4 BLUETOOTH CRADLE SETUP

7.4.1 Cradle Default Setting

Cradle Default Setting
(RS232 Interface, 19200 Baud
None parity, 8 bits, 1 Stop bit)



7.4.1 Cradle Interface

RS232 Interface

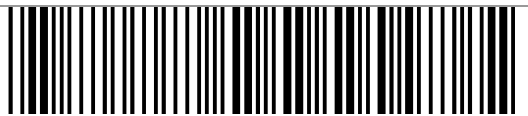

KBW Interface

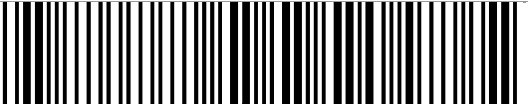

USB Interface



7.4.2 Cradle Pincode Mode

Default Security code
(PINCODE=000000)

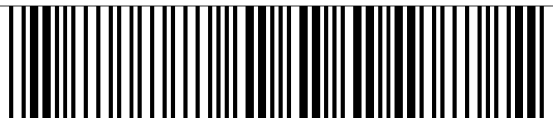

Security Code ON



Security Code OFF



7.4.3 Cradle Pincode Setup

Set PINCODE
Max 6 digits, 0-9 and A-Z ASCII code



Go to ASCII table in Appendix B,
scan 6 labels that represents the
PINCODE



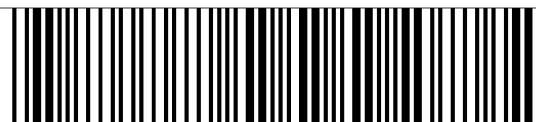



Complete to Set PINCODE





7.5 SCANNER OPERATION

7.5.1 Reading Mode

Default setting is shown with <> in Description.

Good Read <OFF>	
Trigger ON/OFF	
Continuous/Trigger OFF	
Continuous/Auto Power ON	
Flash	
Flash/Auto Power ON	

7.5.2 Good Read Led Control

Good read Led <ON>	
Good read Led OFF	

7.5.3 Beeper option

<High>	
Medium	
Low	
Off	

7.5.4 Reading Level

Bar Equals High	
<Bar Equals Low>	

7.5.5 Accuracy / Redundant Scan

<Original> - Require 1 good decode for a good scan	
1 Redundant Scan - Require 2 consecutive decodes of the same bar code data for a good scan	
2 Redundant Scan - Require 3 consecutive decodes of the same bar code data for a good scan	
3 Redundant Scan - Require 4 consecutive decodes of the same bar code data for a good scan	

7.5.6 Sensitivity of Continuous Reading

This Feature is working under Reading Mode > Continuous modes

<Fast>



Slow



7.5.7 Reverse Output Characters

Example: 012345 → 543210

Enable

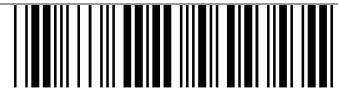

<Disable>



7.6 RS232 MODE PARAMETERS

All section of this chapter are also usable for changing the parameters of the Bluetooth Cradle with RS232 interface.

7.6.1 Baudrate

600	
1200	
2400	
4800	
<9600>	
19200	
38400	





7.6.2 Data / Stop Bits

The number of data bits transmitted for each character

7 Data Bits	
< 8 Data Bits >	
< 1 Stop Bits >	
2 Stop Bits	

7.6.3 Parity

A Parity bit is an extra data bit used to help catch data transmission errors.

<None>	
Even – Select to set the parity bit either a 1 or 0 to ensure an even number of bits are 1's	
Odd – Select to set the parity bit either a 1 or 0 to ensure an odd number of bits are 1's	
Mark – Select to set the parity bit always 1.	
Space– Select to set the parity bit always 0.	

7.6.4 Handshaking

RTS/CTS ON– Output a Request to Send (RTS) signal and wait for a Clear to Send (CTS) signal before transmitting data



RTS/CTS <OFF>



ACK/NAK – After transmitting data, wait for host to send an ACK or a NAK response. If ACK is received, then complete the data transmission. If NAK is received, re-send the last set of data and wait for ACK/NAK again.



ACK/NAK <OFF>



XON/XOFF – After transmitting data, wait for host to send an XON or a XOFF response. If XON is received, then complete the data transmission. If XOFF is received, stop the transmission.



XON/XOFF <OFF>

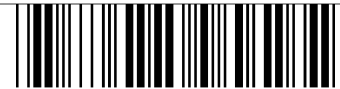

7.7 KEYBOARD WEDGE MODE PARAMETERS

7.7.1 Terminal Type

<IBM PC/AT,PS/2> - Includes IBM PS/2 and compatible models 50, 55, 60, 80	
IBM PC/XT	
PS/2 25, 30	
IBM 5550	
IBM 102 Key	
IBM 122 Key (1)	
IBM 122 Key (2)	
NEC 9800	
Apple Desktop Bus(ADB)	

7.7.2 Country/Language

<US English>



UK English



Italian



Spanish



French



German



Swedish



Switzerland



Hungarian



Japanese



Belgium



Portuguese



Denmark



 Netherlands

 Turkey

7.7.3 Upper/Lower Case

<No Change>

 Enable Lower Case – Transmit all data as lower case

 Enable Upper Case – Transmit all data as upper case

7.7.4 Interscan Code Delay

This section is also usable for changing the parameters of the Bluetooth Cradle .

<No Delay>

 5 msec

 10 msec

 25 msec

 50 msec

100 msec



200 msec











300 msec



7.8 OUTPUT CHARACTERS

7.8.1 Select Terminator













<CR+LF> — The scanner transmits a carriage return and a line feed after each scan	
CR Suffix – The scanner transmits a carriage return after each scan	
LF Suffix – The scanner transmits a line feed after each scan	
Space	
Tab	
Alt	
Disable Alt	
STX-ETX – RS232 only	

7.9 CODE TYPE

7.9.1 Barcode Selections

If “Enable” is selected for all bar codes types, then the scanner could read all types of bar code. If “Disable” is selected for a certain bar code type, then the scanner could not read the particular bar code. The symbol of “<>” means default settings.

All Bar Codes ON	
UPC-A <ON>	
UPC-A OFF	
UPC-E <ON>	
UPC-E OFF	
EAN-13 / JAN-13 <ON>	
EAN-13 / JAN-13 OFF	
EAN-8 / JAN-8 <ON>	
EAN-8 / JAN-8 OFF	

CODE 39 <ON>	
CODE 39 OFF	
Standard Code 39 <ON>	
Full ASCII Code 39 ON	
Code 32 / Italian Pharmacy ON	
Code32 / Italian Pharmacy <OFF>	
Code 128 <ON>	
Code 128 OFF	
Interleaved 2 of 5 <ON>	
Interleaved 2 of 5 OFF	
CODABAR/NW7 <ON>	
CODABAR/NW7 OFF	

Industrial 2 of 5 ON



Industrial 2 of 5 <OFF>



Matrix 2 of 5 ON



Matrix 2 of 5 <OFF>



CODE 93 ON



CODE 93 <OFF>



CODE 11 ON



CODE 11 <OFF>



MSI/PLESSEY ON



MSI/PLESSEY <OFF>



Telepen ON



Telepen <OFF>



China Postage ON



China Postage <**OFF**>



GS1 DataBar ON



GS1 DataBar <**OFF**>



GS1 DataBar Expanded ON



GS1 DataBar Expanded <**OFF**>



GS1 DataBar Limited ON



GS1 DataBar Limited <**OFF**>



7.10 UPC/EAN/JAN PARAMETERS

7.10.1 Reading Type

UPC-A=EAN-13 ON
Add 0 before UPC-A to make it 13 digits.



<UPC-A = EAN-13> <OFF>



ISBN Enable



ISBN <Disable>



ISSN Enable



ISSN <Disable>



Decode with Supplement



<Auto discriminate supplement>



7.10.2 Supplemental Setup

<Not Transmit>



2 Digit Supplemental



5 Digit Supplemental



2 & 5 Digit Supplemental



7.10.3 Check Digit Transmission

UPC-A Check Digit Transmission **<ON>**



UPC-A Check Digit Transmission OFF



UPC-E Check Digit Transmission **<ON>**



UPC-E Check Digit Transmission OFF



EAN-8 Check Digit Transmission **<ON>**



EAN-8 Check Digit Transmission OFF

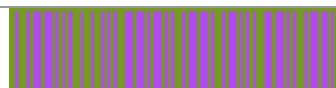

EAN-13 Check Digit Transmission **<ON>**



EAN-13 Check Digit Transmission OFF

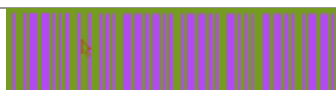

ISSN Check Digit Transmission **<ON>**





ISSN Check Digit Transmission OFF





7.11 CODE 39 PARAMETERS



7.11.1 Type of Code

<Standard Code 39>	
Full ASCII Code 39	

7.11.2 Check Digit Transmission

<Do not Calculate Check Digit>	
Calculate Check Digit and Transmit	
Calculate Check Digit and Not Transmit	

7.11.3 Output Start/Stop Character

Enable	
<Disable>	

7.11.4 Decode Asterisk

Enable



<Disable>

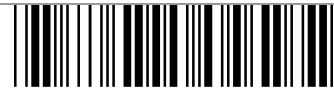

7.11.5 Set Up Code Length

To set the fixed length: (2 sets Available)

1. Scan the "Begin" programming code of the desired set
2. Go to the Decimal Value Tables in Appendix A, scan programming codes that represents the length to be read.
3. Scan the "Complete" programming code of the desired set.

Repeat the steps 1 – 3 to set additional lengths.

<Variable>



Fixed Length 1st Set

1st Set Begin



Decimal Value

See Appendix A

1st Set Complete



Fixed length 2nd Set

2nd Set Begin



Decimal Value

See Appendix A

2nd Set Complete



Minimum length

Minimum Length begin



Decimal Value

See Appendix A

Minimum Length Complete



7.12 CODE 128 PARAMETERS

7.12.1 Check Digit Transmission

Do Not Calculate Check Digit



Calculate Check Digit and Transmit



<Calculate Check Digit and Not Transmit>



7.12.2 Append FNC2

ON



<OFF>

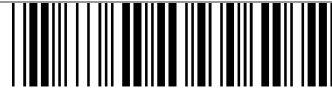

7.12.3 Set Up Code Length

To set the fixed length: (2 sets Available)

1. Scan the "Begin" programming code of the desired set
2. Go to the Decimal Value Tables in Appendix A, scan programming codes that represents the length to be read.
3. Scan the "Complete" programming code of the desired set.

Repeat the steps 1 – 3 to set additional lengths

<Variable>

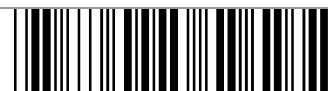

Fixed Length 1st Set1st Set Begin

Decimal Value

See Appendix A

1st Set Complete**Fixed length 2nd Set**2nd Set Begin

Decimal Value

See Appendix A

2nd Set Complete**Minimum length**

Minimum Length begin



Decimal Value

See Appendix A

Minimum Length Complete



7.13 INTERLEAVED 2 OF 5 PARAMETERS

7.13.1 Check Digit Transmission

<Do Not Calculate Check Digit>



Calculate Check Digit and Transmit



Calculate Check Digit and Not Transmit



7.13.2 Set Up Number of Character

<Even>



Odd

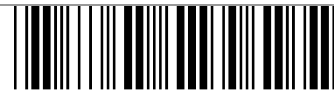

7.13.3 Brazilian Banking Code

Enable



<Disable>



7.13.4 Set Up Code Length

To set the fixed length: (2 sets Available)

- 1 Scan the "Begin" programming code of the desired set
- 2 Go to the Decimal Value Tables in Appendix A, scan programming codes that represents the length to be read.
- 3 Scan the "Complete" programming code of the desired set.

Repeat the steps 1 – 3 to set additional lengths

<Variable>



Fixed Length 1st Set

1st Set Begin



Decimal Value

See Appendix A

1st Set Complete



Fixed length 2nd Set

2nd Set Begin

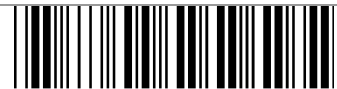

Decimal Value

See Appendix A

2nd Set Complete



Minimum length

Minimum Length begin



Decimal Value



See Appendix A

Minimum Length Complete



7.14 INDUSTRIAL 2 OF 5 PARAMETERS

7.14.1 Check Digit Transmission

<Do Not Calculate Check Digit>	
Calculate Check Digit and Transmit	
Calculate Check Digit and Not Transmit	

7.14.2 Set Up Code Length

To set the fixed length: (2 sets Available)

- 1 1Scan the “Begin” programming code of the desired set
- 2 Go to the Decimal Value Tables in Appendix A, scan programming codes that represents the length to be read.
- 3 Scan the “Complete” programming code of the desired set.

Repeat the steps 1 – 3 to set additional lengths

<Variable>	
Fixed Length 1st Set	
1 st Set Begin	
Decimal Value	See Appendix A
1 st Set Complete	

Fixed length 2nd Set

2nd Set Begin



Decimal Value

See Appendix A

2nd Set Complete

**Minimum length**

Minimum Length begin



Decimal Value



See Appendix A

Minimum Length Complete



7.15 MATRIX 2 OF 5 PARAMETERS

7.15.1 Check Digit Transmission

<Do Not Calculate Check Digit>	
Calculate Check Digit and Transmit	
Calculate Check Digit and Not Transmit	

7.15.2 Set Up Code Length

To set the fixed length: (2 sets Available)

- 1 Scan the "Begin" programming code of the desired set
- 2 Go to the Decimal Value Tables in Appendix A, scan programming codes that represents the length to be read.
- 3 Scan the "Complete" programming code of the desired set.

Repeat the steps 1 – 3 to set additional lengths

<Variable>	
Fixed Length 1st Set	
1 st Set Begin	
Decimal Value	See Appendix A
1 st Set Complete	

Fixed length 2nd Set

2nd Set Begin



Decimal Value

See Appendix A

2nd Set Complete

**Minimum length**

Minimum Length begin



Decimal Value

See Appendix A

Minimum Length Complete

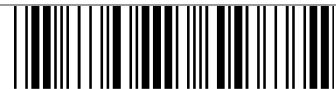

7.16 CODABAR PARAMETERS

7.16.1 Set Up Start/Stop Characters upon Transmission

ON



<OFF>



7.16.2 Transmission Type of Start/Stop

A/B/C/D <Start>

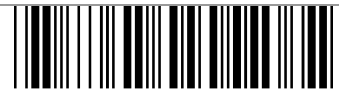

A/B/C/D <Stop>



A Start



A Stop



B Start



B Stop



C Start



C Stop	
D Start	
D Stop	

7.16.3 Set Up Code Length

To set the fixed length: (2 sets Available)

- 1 Scan the "Begin" programming code of the desired set
- 2 Go to the Decimal Value Tables in Appendix A, scan programming codes that represents the length to be read.
- 3 Scan the "Complete" programming code of the desired set.

Repeat the steps 1 – 3 to set additional lengths

<Variable>	
-------------------------	---

Fixed Length 1st Set

1 st Set Begin	
Decimal Value	See Appendix A
1 st Set Complete	

Fixed length 2nd Set

2nd Set Begin



Decimal Value

See Appendix A

2nd Set Complete

**Minimum length**

Minimum Length begin



Decimal Value

See Appendix A

Minimum Length Complete



7.17 CODE 93 PARAMETERS

7.17.1 Check Digit Transmission

Calculate Check Digit Disable



<Calculate Check 2 Digit and Not Transmit>



7.17.2 Set Up Code Length

To set the fixed length: (2 sets Available)

- 1 Scan the "Begin" programming code of the desired set
- 2 Go to the Decimal Value Tables in Appendix A, scan programming codes that represents the length to be read.
- 3 Scan the "Complete" programming code of the desired set.

Repeat the steps 1 – 3 to set additional lengths.

<Variable>



Fixed Length 1st Set

1st Set Begin



Decimal Value

See Appendix A

1st Set Complete



Fixed length 2nd Set

2nd Set Begin



Decimal Value

See Appendix A

2nd Set Complete



Minimum length

Minimum Length Begin



Decimal Value

See Appendix A

Minimum Length Complete



7.18 CODE 11 PARAMETERS

7.18.1 Check Digit Transmission

<Do Not Calculate Check Digit>



Calculate Check 1 Digit and Transmit



Calculate Check 1 Digit and Not Transmit

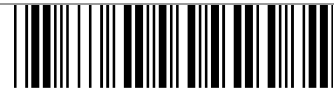

Calculate Check 2 Digit and Transmit



Calculate Check 2 Digit and Not Transmit



7.18.2 Set Up Code Length

To set the fixed length: (2 sets Available)

1. Scan the "Begin" programming code of the desired set
2. Go to the Decimal Value Tables in Appendix A, scan programming codes that represents the length to be read.
3. Scan the "Complete" programming code of the desired set.

Repeat the steps 1 – 3 to set additional lengths.

<Variable>



Fixed Length 1st Set1st Set Begin

Decimal Value

See Appendix A

1st Set Complete**Fixed length 2nd Set**2nd Set Begin

Decimal Value

See Appendix A

2nd Set Complete**Minimum length**

Minimum Length begin



Decimal Value

See Appendix A

Minimum Length Complete



7.19 MSI/PLESSEY CODE PARAMETERS

7.19.1 Check digit transmission

<Do Not Calculate Check Digit>



Calculate Check Digit and Transmit



Calculate Check Digit and Not Transmit

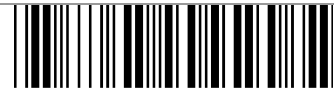

7.19.2 Set Up Code Length

To set the fixed length: (2 sets Available)

1. Scan the "Begin" programming code of the desired set
2. Go to the Decimal Value Tables in Appendix A, scan programming codes that represents the length to be read.
3. Scan the "Complete" programming code of the desired set.

Repeat the steps 1 – 3 to set additional lengths.

<Variable>



Fixed Length 1st Set

1st Set Begin



Decimal Value

See Appendix A

1st Set Complete

**Fixed length 2nd Set**

2nd Set Begin



Decimal Value

See Appendix A

2nd Set Complete

**Minimum length**

Minimum Length begin



Decimal Value

See Appendix A

Minimum Length Complete



7.20 TELEPEN PARAMETERS

7.20.1 Type of Code

Telepen ASCII <ON>



Telepen Numeric



7.20.2 Check Digit Transmission

Do Not Calculate Check Digit

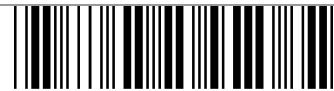

Calculate Check Digit and Transmit



<Calculate Check Digit and Not Transmit>



7.20.3 Set Up Code Length

To set the fixed length: (2 sets Available)

4. Scan the "Begin" programming code of the desired set
5. Go to the Decimal Value Tables in Appendix A, scan programming codes that represents the length to be read.
6. Scan the "Complete" programming code of the desired set.

Repeat the steps 1 – 3 to set additional lengths.

<Variable>



Fixed Length 1st Set

1st Set Begin



Decimal Value

See Appendix A

1st Set Complete

**Fixed length 2nd Set**

2nd Set Begin



Decimal Value

See Appendix A

2nd Set Complete

**Minimum length**

Minimum Length begin



Decimal Value

See Appendix A

Minimum Length Complete



7.21 GS1 DATABAR PARAMETERS

7.21.1 Check Digit Transmission

<Calculate Check Digit and Transmit>



Calculate Check Digit and Not Transmit



7.21.2 Application ID

<Transmit Application ID>

Add 01 before GS1 Databar.



Don't Transmit Application ID



7.21.3 Symbology ID

Transmit Symbology ID

Add 1e0 before GS1 Databar.



<Don't Transmit Symbology ID>



7.22 GS1 DATABAR LIMITED PARAMETERS

7.22.1 Check Digit Transmission

<Calculate Check Digit and Transmit>



Calculate Check Digit and Not Transmit



7.22.2 Application ID

<Transmit Application ID>

Add 01 before GS1 Databar Limited.



Don't Transmit Application ID



7.22.3 Symbology ID

Transmit Symbology ID

Add Je0 before GS1 Databar Limited.



<Don't Transmit Symbology ID>



7.23 GS1 DATABAR EXPANDED PARAMETERS

7.23.1 Symbology ID

Transmit Symbology ID
Add 1e0 before GS1 Databar Expanded.



<Don't Transmit Symbology ID>



Chapter 8 Miscellaneous Parameters

8.1 BAR CODE ID

8.1.1 Default Barcode ID

With this function on, a leading character will be added to the output string while scanning code; user may refer to the following table to know what kind of barcode is being scanned.

Code Type	ID	Code Type	ID
UPC-A	A	UPC-E	B
EAN-8	C	EAN-13	D
Code 39	E	Code 128	F
Interleaved 2 of 5	G	Industrial 2 of 5	H
Matrix 2 of 5	I	Codabar	J
Code 93	K	Code 11	L
China Postage	M	MSI/Plessey	N
Telepen	T	GS1 DataBar	U
GS1 DataBar Lim.	V	GS1 DataBar Exp.	W

Bar Code ID ON



Bar Code ID <OFF>



Default – Return from User Define to Default



8.1.2 User Define Code ID

To set the code ID

1. Scan the symbologies programming code.
2. Go to the ASCII Tables in Appendix B, Scan programming codes that represents the desired ID.

Note: User defines code ID will override default value. Program will not check the conflict. It is possible to have more than two symbologies which have same code ID.

UPC-A



UPC-E



EAN-13/JAN-13



EAN-8/JAN-8



CODE 39



CODE 128



CODABAR



Interleaved 2 of 5



Industrial 2 of 5



Matrix 2 of 5



CODE 93



CODE 11



China Postage



MSI/PLESSEY



Telepen



GS1 DataBar



GS1 DataBar Expanded



GS1 DataBar Limited



8.2 PREAMBLES AND POSTAMBLES INSERTION







8.2.1 Setup Insertion



To set the insertion of the output characters;

1. Scan the programming code of the desired set.
2. Scan the programming code of the desired symbology
3. Go to the Decimal Value in Appendix A, scan programming codes that represents the desired position to be inserted (1= the first digit, 99 the last digit).
4. Scan the “Complete” programming code of “Character Position to be Inserted”.
5. Go to the ASCII Tables in Appendix C, Scan programming codes that represents the desired characters to be inserted.
6. Scan the “Complete” programming code of “Characters to be Inserted”.

Repeat the steps 1 – 6 to set additional insertion.

Example: Insert \$ as Preamble for Code UPC-A.

Start configuration	
1 st Set	
Code UPC-A	
1st digit	
Complete	
\$	

Complete	
End of Configuration bar code	
Save Parameters bar code	

8.2.2 Insertion set number

1 st Set	
2 nd Set	
3 rd Set	
4 th Set	
5 th Set	
6 th Set	

8.2.3 Symbologies Selection

UPC-A



UPC-E



EAN-13/JAN-13



EAN-8/JAN-8



CODE 39



CODE 128



Codabar/NW7



Interleaved 2 of 5



Industrial 2 of 5



Matrix 2 of 5



CODE 93





CODE 11



China Postage



MSI/PLESSEY	
Telepen	
GS1 DataBar	
GS1 DataBar Expanded	
GS1 DataBar limited	
All Codes	
None	

8.2.4 Character Position to be Inserted

Decimal Value	See Appendix A
Complete	

8.2.5 Characters to be Inserted

ASCII Table	See Appendix B and C
Complete	





8.3 CHARACTER DELETION

To setup the deletion of output characters:

1. Scan the programming code of the desired set.
2. Scan the programming code of the desired symbology.
3. Go to the decimal Value tables in Appendix A, scan programming codes that represents the desired position to be deleted.
4. Scan the "Complete" programming code of "Character Position to be Deleted".
5. Go to the Decimal Value Tables in Appendix A, scan programming codes that represents the number of characters to be deleted.
6. Scan the "Complete" programming code of "Number of Characters to be deleted".

Repeat the steps 1 – 6 to set additional deletion.

Example: Delete first 3 codes for Code EAN-13.

Start Configuration	
1 st Set	
Code EAN-13	
1st digit – delete from the 1 st digit	
Complete	
3 – delete 3 characters	
Complete	

End of Configuration bar code



Save Parameters bar code



8.3.1 Deletion Set Number

1st Set



2nd Set



3rd Set



4th Set



5th Set



6th Set



8.3.2 Code Type to be Delete

UPC-A



UPC-E



EAN-13/JAN-13



EAN-8/JAN-8



CODE 39



CODE 128



CODABAR/NW7



Interleaved 2 of 5



Industrial 2 of 5



Matrix 2 of 5



CODE 93



CODE 11



China Postage



MSI/PLESSEY	
Telepen	
GS1 DataBar	
GS1 DataBar Expanded	
GS1 DataBar Limited	
All Codes	
None	

8.3.3 Character Position to be Delete

Decimal Value	See Appendix A
Complete	









8.3.4 Number of Characters to be Delete

Decimal Value	See Appendix A
Complete	

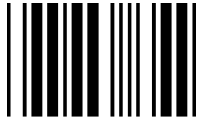















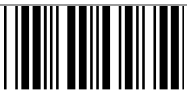
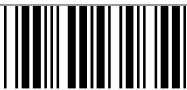







Appendices





















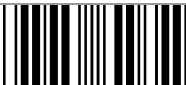





A	Decimal Value Table.....	96
B	ASCII Table.....	97
C	Function Key Table.....	102
D	Readable Symbologies	103
E	Technical Specifications	104
F	Scan Map.....	106
G	Led Indicator Status.....	107
H	Test Symbologies	108
I	Overview Partnumbers	112
J	Quick Configuration.....	115



























A DECIMAL VALUE TABLE

























 0	 1
 2	 3
 4	 5
 6	 7
 8	 9















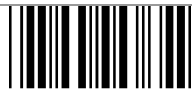







B ASCII TABLE

NULL		RS	
ETX		STX	
ACK		ENQ	
HT		BS	
FF		VT	
SI		SO	
DC2		DC1	
NAK		DC4	
CAN		ETB	
ESC		SUB	
GS		SYN	
SOH		EM	
EOT		FS	























BEL		US	
LF		SPACE	
CR		"	
DLE		!	
DC3		#	
%		0 Number Zero	
\$		1 Number One	
&		2	
(	3	
'		4	
)		5	
+		6	
*		7	
, Comma		8	

.		9	
-		B	
/		C	
;		D	
:		E	
<		F	
Less than			
>		G	
Greater than			
=		H	
?		I	
		Letter I	
@		J	
A		K	
L		T	
M		U	

N		V	
O Letter O		W	
P		X	
Q		Y	
R		Z	
S			
[]	
\		^	
– Underscore		`	
a		h	
b		i	
c		j	
d		k	

e		l	
f		m	
g		n	
o		u	
p		v	
q		w	
r		x	
s		y	
t		z	
{		 Vertical slash	
}		~	
DEL			

C FUNCTION KEY TABLE

F1		F7	
F2		F8	
F3		F9	
F4		F10	
F5		F11	
F6		F12	
Insert		Delete	
Home		End	
Page Up		Page Down	
Left		Up	
Right		Down	

D READABLE SYMBOLOGIES

1D Symbolologies

Symbology	Default Enable	Note
Codabar	Off	
Code 11	Off	
Code 32 / Italian Pharmacy	Off	
Code 39	On	
Code 93	Off	
Code 128	On	
EAN 8 / EAN 13	On	
EAN 128	On	
GS1 DataBar (RSS)	Off	Omni, Expanded, limited
Interleaved 2 of 5	Off	
Industrial 2 of 5	Off	
ISBN	Off	
ISSN	Off	
Matrix 2 of 5	Off	
MSI / PLESSEY	Off	
China Postage	Off	
Telepen	Off	
UPC A / UPC E	On	

E TECHNICAL SPECIFICATIONS

Physical Characteristics Scanner

Weight (V-1010)	Approx 240 gr.
Weight (V-1010BT)	Approx 195 gr. (incl. batteries)
Material	ABS Plastic
Connector	RJ 45C 10Pins
Dimension	186.8 mm x 81.6 mm x 63.9 mm

Physical Characteristics Bluetooth Cradle

Weight	Approx 150 gr.
Material	ABS Plastic
Connector	RJ 45C 10Pins
Dimension	129.9 mm x 120 mm x 71.4 mm

Operational

Light source	639 nm
Scan rate	700 scans/sec $\pm 10\%$
Reading Distance	270 mm
Width of Field	80 mm
Scan angle	Forward & Backward $\pm 70^\circ$, Left & Right $\pm 60^\circ$, Dead Zone $\pm 5^\circ$
Interface	RS232, KBW (PS/2), USB
Indicators (led)	Green = good read

Electrical Characteristics (V-1010 wired model)

Operation Voltage	5 VDC $\pm 5\%$
Current Operating	140 mA (max) @ 5 VDC
Current Standby	50 mA typical @ 5 VDC
AC transformer	5.2 VDC @ 650 mA / Input AC 100-240V

Electrical Characteristics (V-1010BT wireless model)

Battery	Li-ion 3.7V / 1400 mA. Size / 18500 nM
---------	--

Charge time	4.5 hours
-------------	-----------

Reads per charge	30,000
------------------	--------

Cradle LED indicators	Battery charging: red Charge Completed: off Communication: blue
-----------------------	---

Operating Current	280 mA
-------------------	--------

Input Voltage	5 VDC @ 2 A / input AC 110-240V
---------------	---------------------------------

Bluetooth Characteristics

Bluetooth Module	Bluetooth V2.0 standard
------------------	-------------------------

Frequency band	2.402GHz ~ 2.480Ghz
----------------	---------------------

Modulation Method	FHSS, GFSK, GFSK, $\pi/4$ -DQPSK, 8DPSK
-------------------	---

RF Output Power	6.97 dBm (4.977mW)
-----------------	--------------------

Bluetooth Range	Class 2 Up to 10 M / 33 ft (open air)
-----------------	---------------------------------------

Environmental

Operating Temp.	0°C to 50°C (32°F to 122°F)
-----------------	-----------------------------

Storage Temp.	-20°C to 70°C (-4°F to 158°F)
---------------	-------------------------------

Relative Humidity	20 to 95% non-condensing
-------------------	--------------------------

Ambient light	100,000 LUX max @ Direct sun Light
---------------	------------------------------------

Regulatory of Compliance

FCC

CE

RoHs

F SCAN MAP

Typical Reading Distances

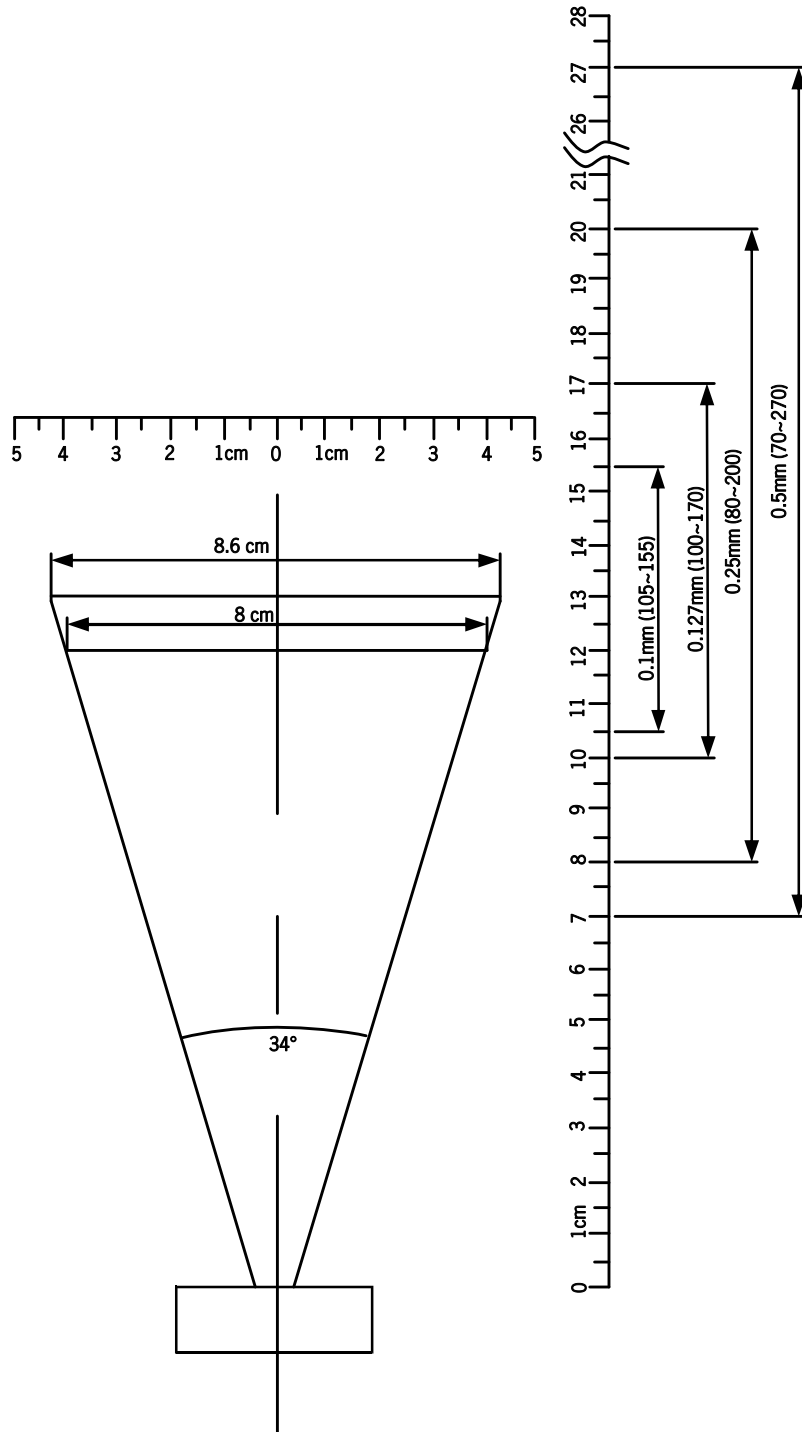

VEGA Typical Reading Distances (Centimetres)

Symbology	Density	Minimum Distance	Maximum Distance
Code 39	0.1 mm	10.5 cm	15.5 cm
	0.127 mm	10 cm	17 cm
	0.25 mm	8 cm	20 cm
	0.5 mm	7 cm	27 cm

VEGA Typical Reading Distances (inches)

Symbology	Density	Minimum Distance	Maximum Distance
Code 39	4 mils	4.1 inch	6.1 inch
	5 mils	3.9 inch	6.7 inch
	10 mils	3.2 inch	7.9 inch
	20 mils	2.8 inch	10.6 inch





G LED INDICATOR STATUS





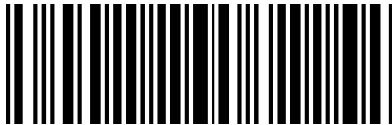

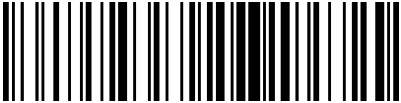

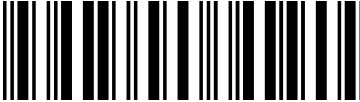
	LIGHT	SIGNAL	STATUS	
Scanner	Green	1 Blink and 1 beep	Good read and transmitted	
			Good read and save on memory (BT disconnect)	
	Red	3 Long blink and 3 long beeps	Memory full	
			4 Blink and beeps	Low Battery warning
			2 Blink and 2 beeps	Good read but transmit fail
	Blue	3 Blink and 3 beeps	BT disconnect	
			Flash (fast)	On connecting
			Flash (slow)	BT disconnect before sleep
			Continuous on and 1 long beep	BT connected
	Red Blue	1 Blink at the same time and 2 beeps	Setting ok	
Green Red Blue	1 Blink taking turns 3 times	Battery changed		
Cradle	Green	1 Blink	Good read and transmitted	
	Red	Continuous on	Battery in charging	
		Off	Charging finished	
	Blue	Flash	BT disconnect	
		Continuous on	BT connected	

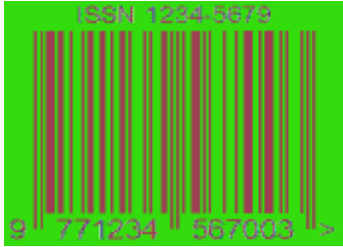

H TEST SYMBOLOGIES

Scan one or more of these bar codes to test bar code symbologies you enabled.

1D Symbology

<p>Codabar</p> 	<p>CODE 11</p> 
<p>CODE 39</p> 	<p>CODE 93</p> 
<p>CODE 128</p> 	<p>EAN 8</p> 
<p>EAN 13</p> 	<p>Interleaved 2 of 5</p> 

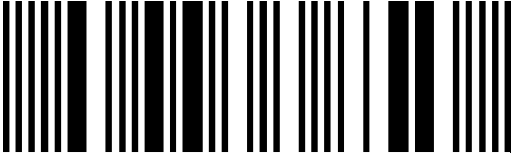
<p>ISBN</p> 	<p>ISSN</p> 
<p>GS1 DataBar</p> 	<p>GS1 DataBar Expanded</p> 
<p>GS1 DataBar Limited</p> 	<p>MSI / Plessey</p> 
<p>Matrix 2 of 5</p> 	<p>Industrial 2 of 5</p> 
<p>UPC A</p> 	<p>UPC B</p> 

<p data-bbox="183 203 311 241">Telepen</p>  A Telepen barcode consisting of vertical black bars of varying widths on a white background. The bars are arranged in several groups of varying lengths and thicknesses.	<p data-bbox="829 203 1053 241">China Postage</p>  A China Postage barcode consisting of vertical bars of varying widths and shades of gray on a white background. The bars are arranged in a single, dense row.
---	--

I OVERVIEW PARTNUMBERS

VEGA with Linear Imager

Version with RS232 interface:

1. A271002 VEGA V-1010-02
2. A272002 VEGA V-1010BT-02

Version with KBW interface:

3. A271003 VEGA V-1010-03
4. A272003 VEGA V-1010BT-03

Version with USB (HID KBW) interface:

5. A271004 VEGA V-1010-04
6. A272004 VEGA V-1010BT-04

Version with USB (virtual com port) interface:

7. A271005 VEGA V-1010-05

J Quick Configuration

Start Configuration



<Select your Settings>

End Configuration



Save Parameters



Set all Defaults



Recall Stored Parameters

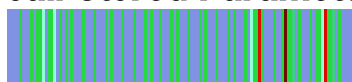

Abort Configuration



Version Information

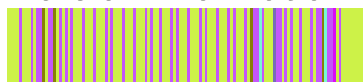

ScantechID BV
Nijverheidsweg Noord 60-34
3812 PM Amersfoort
The Netherlands

Phone: +31 (0)33 469 84 00
Fax: +31 (0)33 465 06 15
E-mail: info@scantech-id.com
Internet: www.scantech-id.com
