



EUROFINS ELECTRICAL TESTING SERVICE (SHENZHEN) CO., LTD.

RADIO TEST - REPORT

FCC Compliance Test Report

Product name: Cordless Pad Transmitter

Model name: TM-12, TM-12B

FCC ID: WNG-TM-12

Test Report Number: EFGX23040170-IE-03-E01

Content

| | | |
|----------|--|----------|
| 1 | General Information | 3 |
| 1.1 | Notes | 3 |
| 1.2 | Testing laboratory | 4 |
| 1.3 | Details of approval holder | 4 |
| 1.4 | Details of Manufacturer | 4 |
| 1.5 | Application details | 4 |
| 1.6 | Test item | 4 |
| 1.7 | Test standards | 5 |
| 2 | Technical test | 6 |
| 2.1 | Summary of test results | 6 |
| 2.2 | Test environment | 6 |
| 2.3 | Measurement uncertainty | 6 |
| 2.4 | Test mode | 6 |
| 2.5 | Test equipment utilized | 7 |
| 2.6 | Auxiliary Equipment Used during Test: | 7 |
| 2.7 | Test software information | 7 |
| 2.8 | Customized Configurations | 7 |
| 2.9 | Test Environments | 7 |
| 2.10 | Test results | 8 |
| 3 | Technical Requirement | 9 |
| 3.1 | Conducted Emission | 9 |
| 3.2 | Automatically Deactivate | 10 |
| 3.3 | 20dB bandwidth | 12 |
| 3.4 | Field strength of fundamental , Field strength of spurious emission for transmitter and Restricted bands | 14 |

1 General Information

1.1 Notes

The results of this test report relate exclusively to the item tested as specified in chapter “Description of test item” and are not transferable to any other test items.

Eurofins Product Testing Service (Shenzhen) Co., Ltd. is not responsible for any generalisations and conclusions drawn from this report. Any modification of the test item can lead to invalidity of test results and this test report may therefore be not applicable to the modified test item.

The test report may only be reproduced or published in full. Reproducing or publishing extracts of the report requires the prior written approval of the Eurofins Product Testing Service (Shenzhen) Co., Ltd.

This document is subject to the General Terms and Conditions and the Testing and Certification System of Eurofins Product Testing Service (Shenzhen) Co., Ltd., available on request or accessible at www.eurofins.com.

Operator:

| | | | |
|------------|--|--------------------------------|---|
| 2023-05-19 | | Bruce Zheng / Project Engineer |  |
|------------|--|--------------------------------|---|

| Date | Eurofins-Lab. | Name / Title | Signature |
|------|---------------|--------------|-----------|
|------|---------------|--------------|-----------|

Technical responsibility for area of testing:

| | | | |
|------------|--|------------------------|---|
| 2023-05-19 | | Abert Xu / Lab Manager |  |
|------------|--|------------------------|---|

| Date | Eurofins-Lab. | Name / Title | Signature |
|------|---------------|--------------|-----------|
|------|---------------|--------------|-----------|

1.2 Testing laboratory

Eurofins Electrical Testing Service (Shenzhen) Co., Ltd.

1st Floor, Building 2, Chungu, Meisheng Huigu Science and Technology Park, No. 83 Dabao Road, Bao'an District, Shenzhen. P.R.China.

Telephone : +86-755-82911867

Fax : +86-755-82910749

The Laboratory has passed the Accreditation by the American Association for Laboratory Accrediation (A2LA). The Accreditation number is 5376.01

The Laboratory has been listed by industry Canada to perform electromagnetic emission measurements, The CAB identifier is CN0088

1.3 Details of approval holder

Name : Rondish Co. Ltd
Address : UNIT G&H, 4/F, Block 1, KWAI TAK IND. CTR, 15-33 K
HONGKONG, China
Telephone : ./.
Fax : ./.

1.4 Details of Manufacturer

Name : Rondish Co. Ltd
Address : UNIT G&H, 4/F, Block 1, KWAI TAK IND. CTR, 15-33 K
HONGKONG, China
Telephone : ./.
Fax : ./.

1.5 Application details

Date of receipt of application : 2023-04-11
Date of receipt of test item : 2023-04-11
Date of test : 2023-04-11 to 2023-04-26
Date of issue : 2023-05-19

1.6 Test item

Product type : Cordless Pad Transmitter
Model name : TM-12, TM-12B
Brand : Rondish
Serial number : N/A
Ratings : 3Vdc supplied by "CR2477" lithium battery.
Test voltage : 3Vdc
FCC ID : WNG-TM-12
PMN : Cordless Pad Transmitter
Additional information : N/A

RadioTechnical data

Frequency range : 433.92MHz
Radio Tech. : N/A
Frequency channel : 1 Channel
Modulation : OOK
Antenna type : Wire antenna

1.7 Test standards

| Test Standards | |
|---------------------------------------|--|
| FCC Part 15 Subpart C 2018 Edition | PART 15 - RADIO FREQUENCY DEVICES Subpart C - Intentional Radiators |

Test Method

- 1: ANSI C63.4-2014, American National Standard for Methods of Measurement of Radio-Noise Emissions from Low-Voltage Electrical and Electronic Equipment in the Range of 9 kHz to 40 GHz.
- 2: ANSI C63.10-2013, American National Standard for Testing Unlicensed Wireless Devices.

2 Technical test

2.1 Summary of test results

No deviations from the technical specification(s) were ascertained in the course of the tests performed.

or

The deviations as specified were ascertained in the course of the tests performed.

2.2 Test environment

Temperature : 20 ... 25°C
 Relative humidity content : 30 ... 60%
 Air pressure : 100 ... 101kPa

2.3 Measurement uncertainty

The uncertainty is calculated using the methods suggested in the "Guide to the Expression of Uncertainty in Measurement" (GUM) published by ISO.

| System Measurement Uncertainty | |
|--|---|
| Test Items | Extended Uncertainty |
| Uncertainty for Conducted RF test | RF Power Conducted: 1.16dB Frequency test involved: 1.05×10 ⁻⁷ or 1% |
| Uncertainty for Radiated Spurious Emission 25MHz-3000MHz | Horizontal: 4.46dB; Vertical: 4.54dB; |
| Uncertainty for Radiated Spurious Emission 3000MHz-18000MHz | Horizontal: 4.42dB; Vertical: 4.41dB; |
| Uncertainty for Radiated Spurious Emission 18000MHz-40000MHz | Horizontal: 4.63dB; Vertical: 4.62dB; |

2.4 Test mode

The EUT was set at continuously transmitting during the test.

2.5 Test equipment utilized

| EQUIPMENT ID | EQUIPMENT NAME | MODEL NO. | CAL. DUE DATE |
|--------------|--------------------------|-------------------|---------------|
| 23-2-13-01 | EMI Test Receiver | ESR7 | 2024-03-21 |
| 23-2-13-02 | Signal Analyzer | N9030A | 2024-03-21 |
| 23-2-12-01 | Active Loop Antenna | FMZB 1519B | 2024-05-29 |
| 23-2-12-02 | TRILOG Broadband Antenna | VULB9168 | 2024-05-29 |
| 23-2-12-03 | Horn Antenna | 3117 | 2024-05-29 |
| 23-2-12-04 | Horn Antenna | BBHA 9170 | 2024-05-29 |
| 23-2-10-01 | Preamplifier | BBV9745 | 2024-03-21 |
| 23-2-10-02 | Preamplifier | EMC001330 | 2024-03-21 |
| 23-2-10-03 | Preamplifier | EMC051845SE | 2024-03-21 |
| 23-2-10-14 | Switch and Control Unit | ERIT-E-JS0806-SF1 | N/A |

2.6 Auxiliary Equipment Used during Test:

| DESCRIPTION | MANUFACTURER | MODEL NO. | S/N |
|-------------|--------------|-----------|-----|
| N/A | N/A | N/A | N/A |

2.7 Test software information

| | | | |
|-----------------------|------------------|------------|-------------|
| Test Software Version | N/A | | |
| Modulation | Setting TX Power | TX Pattern | Packet Type |
| ASK | Default | Default | Default |

2.8 Customized Configurations

| EUT Conf. | Signal Description | Operating Frequency | Duty Cycle |
|-----------|--------------------|---------------------|------------|
| TM1 | OOK | 433.92MHz | 59.98% |

2.9 Test Environments

| Environment Parameter | Temperature | Voltage | Relative Humidity |
|-----------------------|-------------|---------|-------------------|
| 101.7Kpa | 26.5°C | 3Vdc | 51.7% |

2.10 Test results

 1st test

 test after modification

 production test

| Technical Requirements | | | | |
|---------------------------------------|-------------------------------------|-------------|---------|-----------|
| FCC Part 15 Subpart C | | | | |
| Test Condition | | Test Result | Verdict | Test Site |
| §15.207 | Conducted emission AC power port | -- | N/A | -- |
| §15.231(a)(1) | Automatically Deactivate | Page 11 | Pass | Site 1 |
| §15.231(b)(3) | Field strength of fundamental | Page 18 | Pass | Site 1 |
| §15.231(b)(3) §15.209 & §15.205 | Field strength of spurious emission | Page 19 | Pass | Site 1 |
| §15.231(c) | -20dB Bandwidth | Page 13 | Pass | Site 1 |
| §15.203 | Antenna requirement | See note 1 | Pass | -- |

Remark 1: N/A – Not Applicable.

Note 1: The EUT uses a wire antenna, According to §15.203, it is considered sufficiently to comply with the provisions of this section.

3 Technical Requirement

3.1 Conducted Emission

Test Method:

The test method was referred to the subclause 5.2 of ANSI C63.4-2014.

1. The EUT was placed on a table, which is 0.8m above ground plane
2. The power line of the EUT is connected to the AC mains through a Artificial Mains Network (A.M.N.).
3. Maximum procedure was performed to ensure EUT compliance
4. A EMI test receiver is used to test the emissions from both sides of AC line

Test Setup:

The mains cable of the EUT (per AC/DC Adapter) must be connected to LISN. The LISN shall be placed 0.8 m from the boundary of EUT and bonded to a ground reference plane for LISN mounted on top of the ground reference plane. This distance is between the closest points of the LISN and the EUT. All other units of the EUT and associated equipment shall be at least 0.8m from the LISN.

Ground connections, where required for safety purposes, shall be connected to the reference ground point of the LISN and, where not otherwise provided or specified by the manufacturer, shall be of same length as the mains cable and run parallel to the mains connection at a separation distance of not more than 0.1 m.

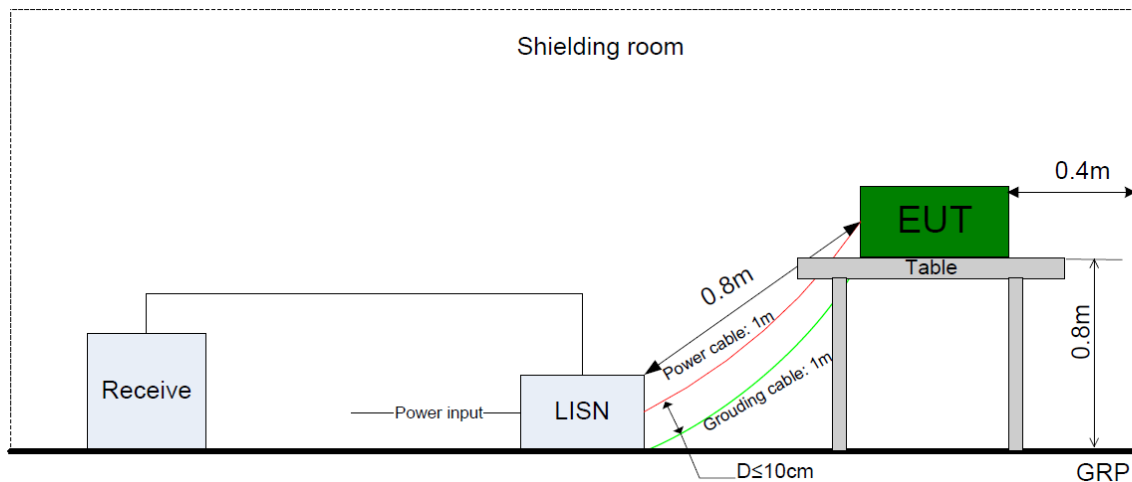

Limit:

| Frequency MHz | QP Limit dB μ V | AV Limit dB μ V |
|------------------|------------------------|------------------------|
| 0.150-0.500 | 66-56* | 56-46* |
| 0.500-5 | 56 | 46 |
| 5-30 | 60 | 50 |

Decreasing linear.

Test Result:

Not Applicable

3.2 Automatically Deactivate

Test Method

1. Connect EUT test port to spectrum analyzer.
2. Set the EUT to transmit maximum output power at 2405MHz.
3. RBW=1MHz, VBW \geq 3RBW, Span=0MHz, Sweep = 10s, Detector function = Average, Sweep time = single
4. Remark transmission time and record test plot.

Test Setup:

The component's antenna ports(s) of the EUT are connected to the measurement instrument per an appropriate attenuator. The press a button of the EUT is to emit the specified signals for the purpose of measurements.

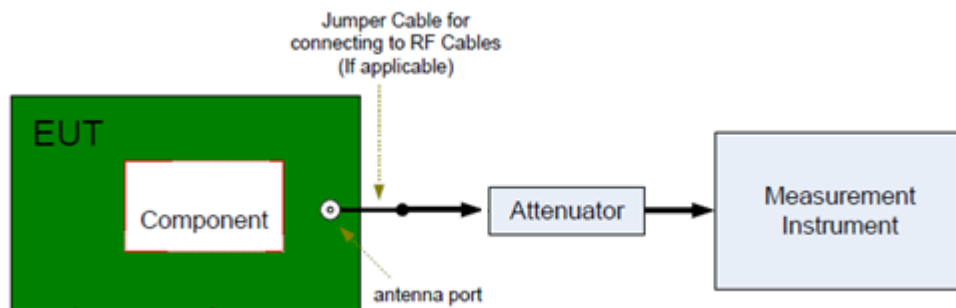

Limits:

According to §15.231 (a) (1), automatically deactivate limit as below:

- (2) A transmitter activated automatically shall cease transmission within 5 seconds after activation.

Test Data:

| | | |
|--------------------------|-------------|--------|
| Time of Transmitting (s) | Limit (sec) | Result |
| 1.04 | 1.32 | Pass |

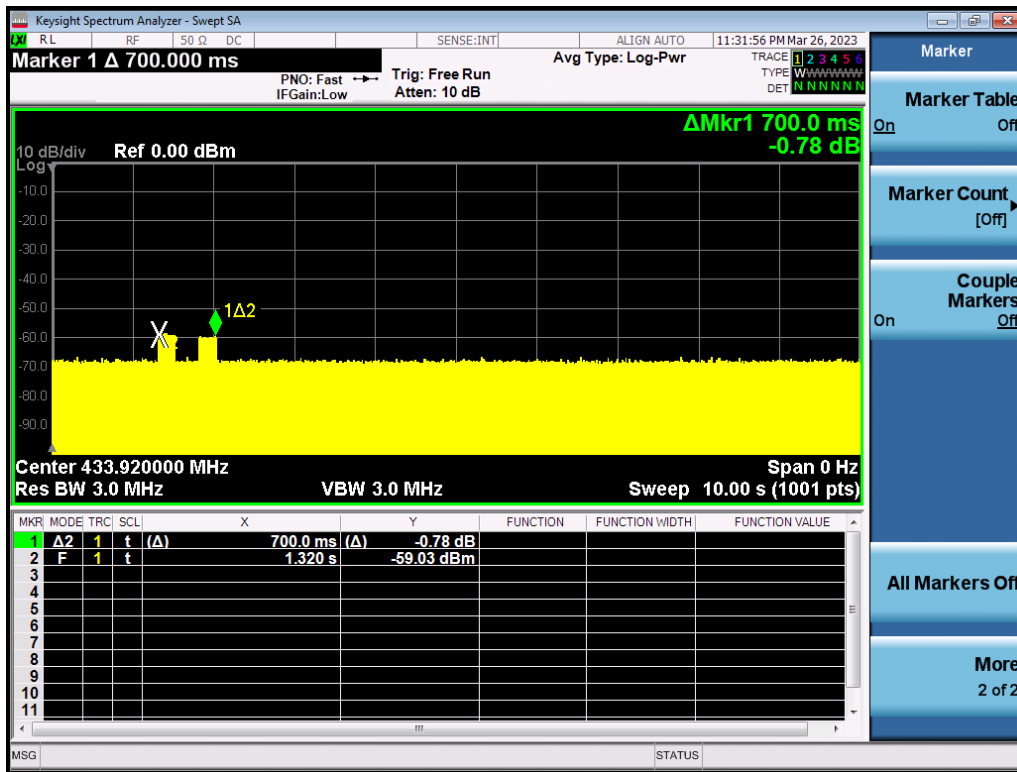

Test Result: Pass

3.3 20dB bandwidth

Test Method:

1. Connect EUT test port to spectrum analyzer.
2. Set the EUT to transmit maximum output power at 2405MHz.
3. Then set the EUT to transmit at high, middle and low frequency separately.
4. Set Span = approximately 1.5 to 5 times the 99% bandwidth.
5. Set RBW \geq 1% to 5% of the 99% bandwidth, VBW \geq RBW.
6. Set Sweep = auto.
7. Set Detector function = Average.
8. Allow the trace to stabilize.
9. Repeat above procedures until all frequencies measured were complete.

Test Setup:

The component's antenna ports(s) of the EUT are connected to the measurement instrument per an appropriate attenuator. The press a button of the EUT is to emit the specified signals for the purpose of measurements.

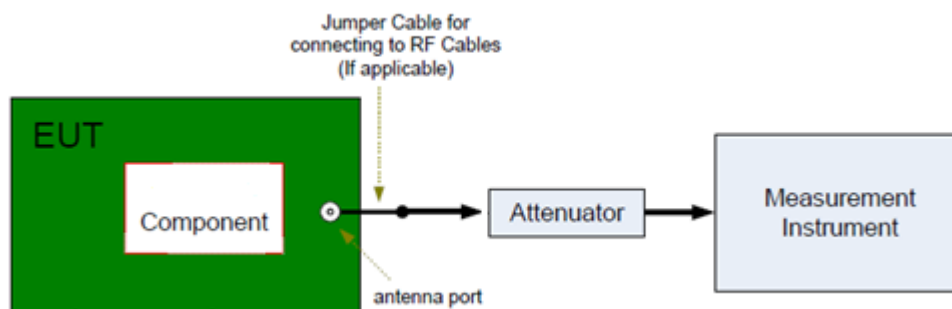

Limit:

According to §15.231 (c), automatically deactivate limit as below:

The bandwidth of the emission shall be no wider than 0.25% of the center frequency for devices operating above 70 MHz and below 900 MHz.

Test Result

| 20dB Bandwidth (KHz) | Limit (KHz) | Result |
|----------------------|-------------|--------|
| 950 | 1084.8 | Pass |

3.4 Field strength of fundamental , Field strength of spurious emission for transmitter and Restricted bands

Test Method:

1: The EUT was placed on a turn table which is 1.5m above ground plane for above 1GHz and 0.8m above ground for below 1GHz at 3 meter chamber room for test. The table was rotated 360 degrees to determine the position of the highest radiation.

2: The EUT was set 3 meters away from the interference – receiving antenna, which was mounted on the top of a variable – height antenna tower.

3: The height of antenna is varied from one meter to four meters above the ground to determine the maximum value of the field strength. Both horizontal and vertical polarizations of the antenna are set to make the measurement.

4: For each suspected emission, the EUT was arranged to its worst case and then the antenna was tuned to heights from 1 meter to 4 meters and the rotatable table was turned from 0 degrees to 360 degrees to find the maximum reading.

5: Use the following spectrum analyzer settings According to C63.10:

For Above 1GHz

Span = wide enough to capture the peak level of the in-band emission and all spurious
RBW = 1MHz, VBW \geq RBW for peak measurement and VBW = 10Hz for average measurement, Sweep = auto, Detector function = peak, Trace = max hold.

For Below 1GHz

Use the following spectrum analyzer settings:

Span = wide enough to capture the peak level of the in-band emission and all spurious
RBW = 100 KHz, VBW \geq RBW for peak measurement, Sweep = auto, Detector function = peak, Trace = max hold.

For Below 30MHz

Use the following spectrum analyzer settings:

Span = wide enough to capture the peak level of the in-band emission and all spurious
RBW = 200 Hz, VBW \geq RBW from 9KHz to 0.15MHz, RBW 9KHz VBW \geq RBW from 0.15MHz to 30MHz for peak measurement, Sweep = auto, Detector function = peak, Trace = max hold.

Note:

1: The resolution bandwidth and video bandwidth of test receiver/spectrum analyzer is 120 KHz for Quasi-peak detection (QP) at frequency below 1GHz.

2: The resolution bandwidth of test receiver/spectrum analyzer is 1MHz and the video bandwidth is 3MHz for peak detection (PK) at frequency above 1GHz.

3: The resolution bandwidth of test receiver/spectrum analyzer is 1MHz and the video bandwidth is 3MHz for RMS Average ((duty cycle < 98%) for Average detection (AV) at frequency above 1GHz, then the measurement results was added to a correction factor (20log(1/duty cycle)).

4: The resolution bandwidth of test receiver/spectrum analyzer is 1MHz and the video bandwidth is 10Hz (duty cycle > 98%) for Average detection (AV) at frequency above 1GHz.

Test Setup:

Test Setup 1: Radiated Emission test below 30MHz

The test site semi-anechoic chamber has met the requirement of NSA tolerance 4 dB according to the standards: ANSI C63.4. The test distance is 3m. The setup is according to ANSI C63.4.

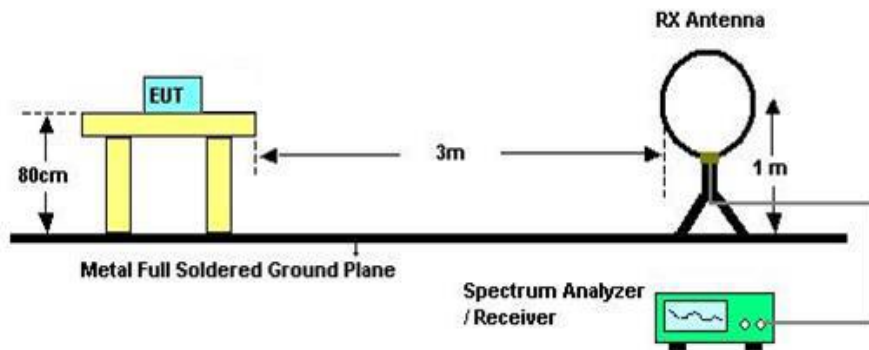

Test Setup 2: Radiated Emission test below 1GHz

The test site semi-anechoic chamber has met the requirement of NSA tolerance 4 dB according to the standards: ANSI C63.4. The test distance is 3m. The setup is according to ANSI C63.4.

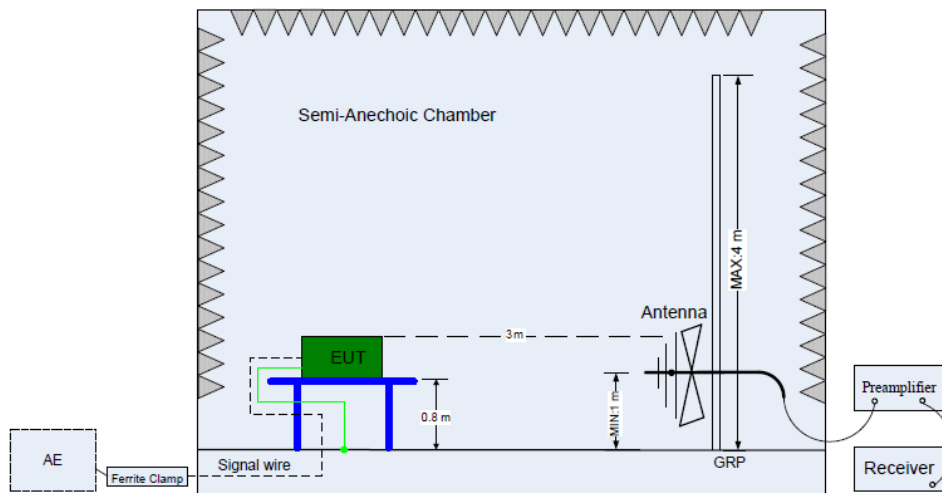

Test Setup 3: Radiated Emission test above 1GHz

The test site semi-anechoic chamber has met the requirement of NSA tolerance 4 dB according to the standards: ANSI C63.4. The test distance is 3m. The setup is according to ANSI C63.4.

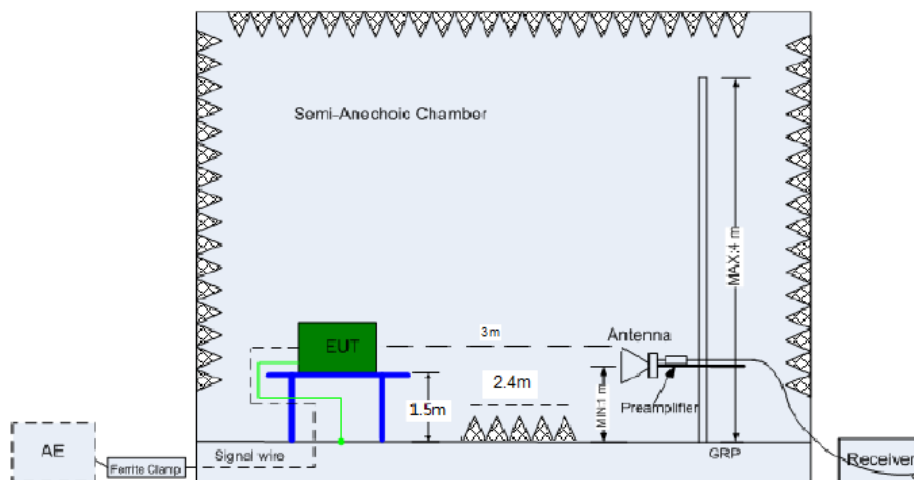

Limit:

Radiated emissions which fall in the restricted bands, as defined in section 15.205, must comply with the radiated emission limits specified in section 15.209.

§ 15.209

| Frequency MHz | Field Strength uV/m | Field Strength dBµV/m | Detector |
|------------------|------------------------|--------------------------|----------|
| 30-88 | 100 | 40 | QP |
| 88-216 | 150 | 43.5 | QP |
| 216-960 | 200 | 46 | QP |
| 960-1000 | 500 | 54 | QP |
| Above 1000 | 500 | 54 | AV |
| Above 1000 | 5000 | 74 | PK |

§15.205 Restricted bands of operation

| MHz | MHz | MHz | GHz |
|--------------------------|---------------------|---------------|------------------|
| 0.090-0.110 | 16.42-16.423 | 399.9-410 | 4.5-5.15 |
| ¹ 0.495-0.505 | 16.69475-16.69525 | 608-614 | 5.35-5.46 |
| 2.1735-2.1905 | 16.80425-16.80475 | 960-1240 | 7.25-7.75 |
| 4.125-4.128 | 25.5-25.67 | 1300-1427 | 8.025-8.5 |
| 4.17725-4.17775 | 37.5-38.25 | 1435-1626.5 | 9.0-9.2 |
| 4.20725-4.20775 | 73-74.6 | 1645.5-1646.5 | 9.3-9.5 |
| 6.215-6.218 | 74.8-75.2 | 1660-1710 | 10.6-12.7 |
| 6.26775-6.26825 | 108-121.94 | 1718.8-1722.2 | 13.25-13.4 |
| 6.31175-6.31225 | 123-138 | 2200-2300 | 14.47-14.5 |
| 8.291-8.294 | 149.9-150.05 | 2310-2390 | 15.35-16.2 |
| 8.362-8.366 | 156.52475-156.52525 | 2483.5-2500 | 17.7-21.4 |
| 8.37625-8.38675 | 156.7-156.9 | 2690-2900 | 22.01-23.12 |
| 8.41425-8.41475 | 162.0125-167.17 | 3260-3267 | 23.6-24.0 |
| 12.29-12.293 | 167.72-173.2 | 3332-3339 | 31.2-31.8 |
| 12.51975-12.52025 | 240-285 | 3345.8-3358 | 36.43-36.5 |
| 12.57675-12.57725 | 322-335.4 | 3600-4400 | (²) |
| 13.36-13.41 | | | |

§15.231 (b) In addition to the provisions of §15.205, the field strength of emissions from intentional radiators operated under this section shall not exceed the following:

| Fundamental frequency (MHz) | Field strength of fundamental (microvolts/meter) | Field strength of spurious emissions (microvolts/meter) |
|--------------------------------|---|--|
| 40.66-40.70 | 2,250 | 225 |
| 70-130 | 1,250 | 125 |
| 130-174 | ¹ 1,250 to 3,750 | ¹ 125 to 375 |
| 174-260 | 3,750 | 375 |
| 260-470 | ¹ 3,750 to 12,500 | ¹ 375 to 1,250 |
| Above 470 | 12,500 | 1,250 |

* Linear interpolation with frequency, f, in MHz:

For 130-174 MHz: Field Strength ($\mu\text{V}/\text{m}$) = $(56.82 \times f) - 6136$

For 260-470 MHz: Field Strength ($\mu\text{V}/\text{m}$) = $(41.67 \times f) - 7083$

Note 1: Frequency bands 225-328.6 MHz and 335.4-399.9 MHz are designated for the exclusive use of the Government of Canada. Manufacturers should be aware of possible harmful interference and degradation of their licence-exempt radio equipment in these frequency bands.

Field Strength of the Fundamental Emissions

The limit on peak radio frequency emissions is 20 dB above the maximum permitted average emission limit.

Fundamental Average ($\text{dB}\mu\text{V}/\text{m}$) = $80.82\text{dB}\mu\text{V}/\text{m}$ (Average)

Fundamental Peak ($\text{dB}\mu\text{V}/\text{m}$) = $80.82\text{dB}\mu\text{V}/\text{m} + 20 = 100.82\text{dB}\mu\text{V}/\text{m}$

Field Strength of the Spurious Emissions

The limit on peak radio frequency emissions is 20 dB above the maximum permitted average emission limit.

Fundamental Average ($\text{dB}\mu\text{V}/\text{m}$) = $60.82\text{dB}\mu\text{V}/\text{m}$ (Average)

Fundamental Peak ($\text{dB}\mu\text{V}/\text{m}$) = $60.82\text{dB}\mu\text{V}/\text{m} + 20 = 80.82\text{dB}\mu\text{V}/\text{m}$

Remark:

- (1) “*” means the emission(s) appear within the restrict bands shall follow the requirement of section 15.205.
- (2) Data of measurement within this frequency range shown “--” in the table above means the reading of emissions are the noise floor or attenuated more than 20dB below the permissible limits or the field strength is too small to be measured.
- (3) Above 1GHz: Corrector factor = Antenna Factor + Cable Loss - Amplifier Gain.
- (4) Below 1GHz: Corrector factor = Antenna Factor + Cable Loss - Amplifier Gain.
- (5) Note: The low frequency, which started from 9 kHz to 30MHz with X/Y/Z axis, was pre-scanned and the result which was 20dB lower than the limit line per 15.31(o) was not reported.

Field Strength of the Fundamental Emissions
PK

| NO. | Freq. [MHz] | Level [dB μ V/m] | Factor [dB/m] | Limit [dB μ V/m] | Margin [dB] | Height [cm] | Angle [°] | Polarity | Verdict |
|-----|-------------|----------------------|---------------|----------------------|-------------|-------------|-----------|------------|---------|
| 1 | 433.92 | 80.71 | -13.05 | 100.82 | 20.11 | 100 | 137 | Horizontal | PASS |
| 2 | 433.92 | 74.24 | -13.05 | 100.82 | 26.58 | 200 | 54 | Vertical | PASS |

Field strength of spurious emission for transmitter 30MHz – 1GHz

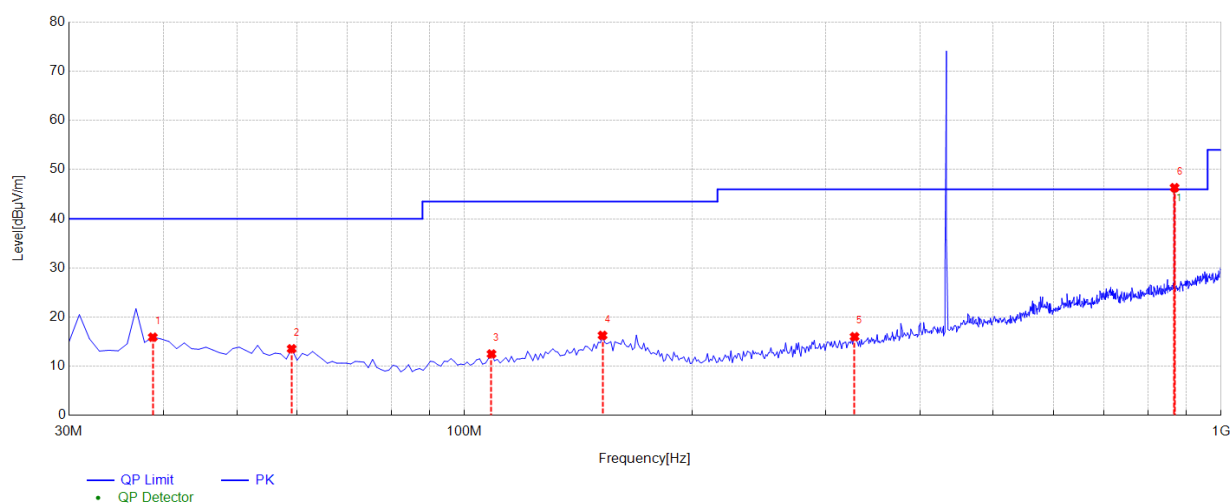

| NO. | Freq. [MHz] | Level [dB μ V/m] | Factor [dB/m] | Limit [dB μ V/m] | Margin [dB] | Height [cm] | Angle [°] | Polarity | Verdict |
|-----|-------------|----------------------|---------------|----------------------|-------------|-------------|-----------|----------|---------|
| 1 | 38.73 | 15.92 | -15.65 | 40.00 | 24.08 | 200 | 65 | Vertical | PASS |
| 2 | 59.1 | 13.56 | -17.09 | 40.00 | 26.44 | 200 | 74 | Vertical | PASS |
| 3 | 108.57 | 12.51 | -19.13 | 43.50 | 30.99 | 200 | 10 | Vertical | PASS |
| 4 | 152.22 | 16.29 | -15.61 | 43.50 | 27.21 | 200 | 357 | Vertical | PASS |
| 5 | 327.79 | 16.03 | -15.08 | 46.00 | 29.97 | 200 | 102 | Vertical | PASS |
| 6 | 868.08 | 46.33 | -4.37 | 80.82 | 34.49 | 200 | 88 | Vertical | PASS |

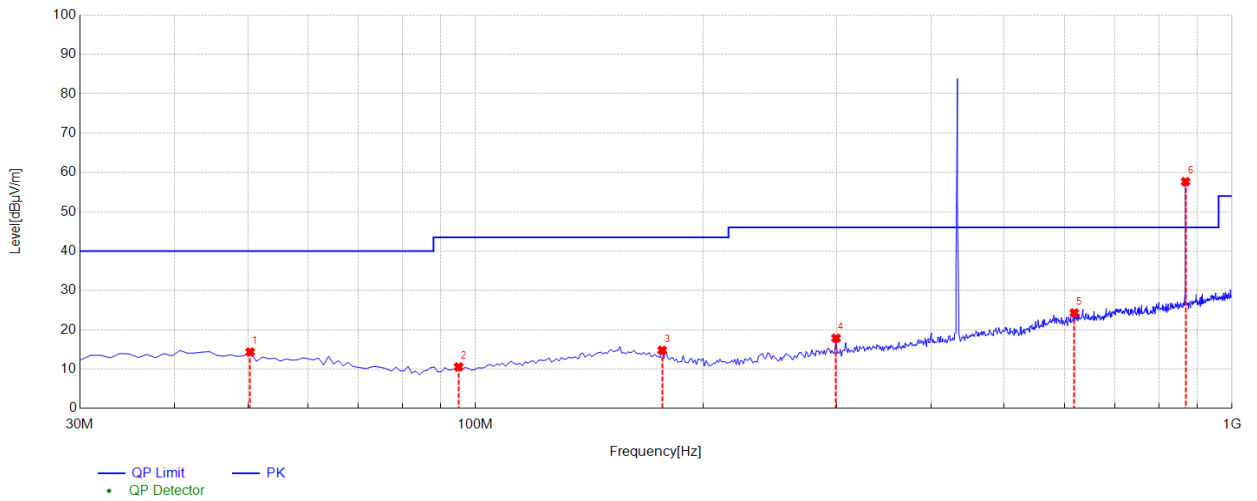

| NO. | Freq. [MHz] | Level [dBµV/m] | Factor [dB/m] | Limit [dBµV/m] | Margin [dB] | Height [cm] | Angle [°] | Polarity | Verdict |
|-----|-------------|----------------|---------------|----------------|-------------|-------------|-----------|------------|---------|
| 1 | 50.37 | 14.36 | -16.34 | 40.00 | 25.64 | 200 | 312 | Horizontal | PASS |
| 2 | 94.99 | 10.58 | -20.04 | 43.50 | 32.92 | 200 | 172 | Horizontal | PASS |
| 3 | 176.47 | 14.80 | -17.34 | 43.50 | 28.70 | 100 | 61 | Horizontal | PASS |
| 4 | 299.66 | 17.87 | -15.82 | 46.00 | 28.13 | 200 | 153 | Horizontal | PASS |
| 5 | 618.79 | 24.29 | -8.19 | 46.00 | 21.71 | 200 | 360 | Horizontal | PASS |
| 6 | 868.08 | 57.66 | -4.37 | 80.82 | 23.16 | 100 | 111 | Horizontal | PASS |

Field strength of spurious emission for transmitter above 1GHz

According to C63.10, if the peak (or quasi-peak) measured value complies with the average limit, it is unnecessary to perform an average measurement, so AV emission value did not show in below table if the peak value complies with average limit.

| NO. | Freq. [MHz] | Reading [dB μ V/m] | Level [dB μ V/m] | Factor [dB/m] | Limit [dB μ V/m] | Margin [dB] | Height [cm] | Angle [°] | Polarity | Verdict |
|-----|-------------|------------------------|----------------------|---------------|----------------------|-------------|-------------|-----------|----------|---------|
| 1 | 1302.4605 | 69.13 | 52.09 | -17.04 | 74.00 | 21.91 | 150 | 225 | Vertical | PASS |
| 2 | 1734.5469 | 67.75 | 48.76 | -18.99 | 74.00 | 25.24 | 150 | 168 | Vertical | PASS |
| 3 | 2415.083 | 61.68 | 46.66 | -15.02 | 74.00 | 27.34 | 150 | 8 | Vertical | PASS |
| 4 | 2924.5849 | 59.74 | 45.03 | -14.71 | 74.00 | 28.97 | 150 | 193 | Vertical | PASS |
| 5 | 3995.7992 | 58.84 | 43.84 | -15.00 | 74.00 | 30.16 | 150 | 8 | Vertical | PASS |
| 6 | 5610.7221 | 56.87 | 44.04 | -12.83 | 74.00 | 29.96 | 150 | 204 | Vertical | PASS |

| NO. | Freq. [MHz] | Reading [dB μ V/m] | Level [dB μ V/m] | Factor [dB/m] | Limit [dB μ V/m] | Margin [dB] | Height [cm] | Angle [°] | Polarity | Verdict |
|-----|-------------|------------------------|----------------------|---------------|----------------------|-------------|-------------|-----------|------------|---------|
| 1 | 1302.4605 | 73.76 | 56.72 | -17.04 | 74.00 | 17.28 | 150 | 126 | Horizontal | PASS |
| 2 | 1736.3473 | 76.95 | 57.98 | -18.97 | 74.00 | 16.02 | 150 | 313 | Horizontal | PASS |
| 3 | 2170.234 | 63.56 | 46.90 | -16.66 | 74.00 | 27.10 | 150 | 48 | Horizontal | PASS |
| 4 | 2548.3097 | 61.50 | 46.53 | -14.97 | 74.00 | 27.47 | 150 | 177 | Horizontal | PASS |
| 5 | 3286.4573 | 59.53 | 44.45 | -15.08 | 74.00 | 29.55 | 150 | 316 | Horizontal | PASS |
| 6 | 5815.9632 | 56.93 | 43.76 | -13.17 | 74.00 | 30.24 | 150 | 16 | Horizontal | PASS |

END