



RF Test Report

Issued Date: Jul. 26, 2019

Applicant : RONDISH CO., LTD
 Product Type : Cordless Monitor
 Trade Name : Rondish
 Model Number : NGM-31, CSM-BC600
 FCC ID : WNG-NGM-31
 EUT Rated Voltage : DC 6 V
 Test Voltage : AC 120 V, 60 Hz
 Applicable Standard : FCC 47 CFR PART 15 SUBPART C
 ANSI C63.10:2013
 Receive Date : Jul. 05, 2019
 Test Period : Jul. 18, 2019

Testing Laboratory

A Test Lab Techno Corp.
 101-104, 1F, A building, Safflower ridge industrial area,
 Taoyuan street, Nanshan district, Shenzhen
 Tel : +86-755-23987770 / Fax : +86-755-26637771
<http://www.atl-lab.com.tw/e-index.htm>



American Association for Laboratory Accreditation number: 3464.02
 Test Firm MRA designation number: CN1168

Note:

- 1.The test results are valid only for samples provided by customers and under the test conditions described in this report.
- 2.This report shall not be reproduced except in full, without the written approval of A Test Lab Technology Corporation.
- 3.The relevant information is provided by customers in this test report. According to the correctness, appropriateness or completeness of the information provided by the customer, if there is any doubt or error in the information which affects the validity of the test results, the laboratory does not take the responsibility.

Approved By : Jet Lu Reviewed By : Louis Shen
 (Manager) (Jet Lu) (Testing Engineer) (Louis Shen)



Revision History

Rev.	Issue Date	Revisions
00	Jul. 26, 2019	Initial Issue



TABLE OF CONTENTS

1	General Information	4
1.1.	Summary of Test Result.....	4
1.2.	Measurement Uncertainty.....	4
2	EUT Description.....	5
3	Test Methodology.....	5
3.1.	Mode of Operation	5
3.2.	EUT Test Step.....	6
3.3.	Configuration of Test System Details	6
3.4.	Test Instruments	7
3.5.	Test Site Environment.....	7
4	Measurement Procedure.....	8
4.1.	AC Power Line Conducted Emission Measurement	8
4.2.	Radiated Emissions Measurement	10
4.3.	20 dB Bandwidth Measurement.....	14
4.4.	Antenna Requirement.....	15
5	Test Results	16
	Annex A. Conducted Emission	16
	Annex B. Conducted Test Results	18
	Annex C. Radiated Emissions Measurement	19

1 General Information

1.1. Summary of Test Result

Standard	Item	Results	Remark
15.207	AC Power Conducted Emission	PASS	----
15.231(a)	Transmitter Deactivation Time	PASS	----
15.231(b)	Transmitter Radiated Emissions	PASS	----
15.231(c)	20 dB Bandwidth	PASS	----
15.203	Antenna Requirement	PASS	----
CFR 47 Part 15.231(2010) / ANSI C63.10:2013			

Standard	Description
CFR47, Part 15, Subpart C	Intentional Radiators
ANSI C63. 10: 2013	American National Standard of Procedures for Compliance Testing of Unlicensed Wireless Devices

1.2. Measurement Uncertainty

Test Item	Frequency Range	Uncertainty (dB)
Conducted Emission	150 kHz ~ 30 MHz	2.7
Radiated Emission	30 MHz ~ 1000 MHz	1.7
	1000 MHz ~ 18000 MHz	5.7
	18000 MHz ~ 26500 MHz	5.5
	26500 MHz ~ 40000 MHz	4.8
	RF Bandwidth	4.96 %

Decision Rule

- Uncertainty is not included.
- Uncertainty is included.

2 EUT Description

Applicant	RONDISH CO., LTD Unit G & H, 4/F, Block 1, Kwai Tak Ind. Ctr, 15-33 Kwai Tak St., Kwai Chung, N.T. Hong Kong
Manufacturer	RONDISH CO., LTD Unit G & H, 4/F, Block 1, Kwai Tak Ind. Ctr, 15-33 Kwai Tak St., Kwai Chung, N.T. Hong Kong
Product Type	Cordless Monitor
Trade Name	Rondish
Model Number	NGM-31, CSM-BC600
Models different description	Due to market demand, only difference in silkscreen printing, rest of the spare parts such as circuit design and printed circuit boards remain the same.
FCC ID	WNG-NGM-31
Frequency Range	433.92 MHz
Modulation Type	ASK
Number of Channels	1 Channel
Antenna Type	Wire Antenna
Operate Temp. Range	0 ~ +40 °C

3 Test Methodology

3.1. Mode of Operation

Test Mode
Mode 1: Transmitter Mode
Mode 2: Continuous TX Mode

Then, the above highest fundamental level mode of the configuration of the EUT and antenna was chosen for all final test items.

By preliminary testing and verifying three axis (X, Y and Z) position of EUT transmitted status, it was found that "Z axis" position was the worst, then the final test was executed the worst condition and test data were recorded in this report.

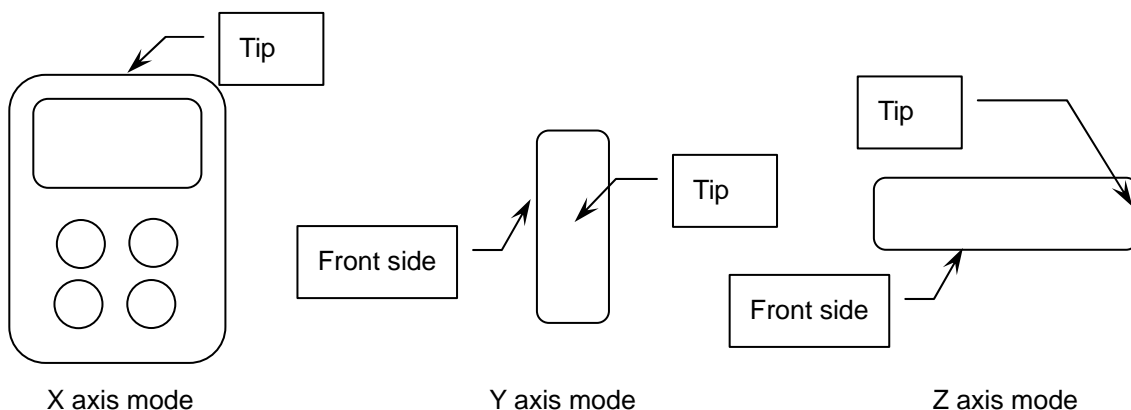

3.2. EUT Test Step

1.	Setup the EUT shown on "Configuration of Test System Details".
2.	Turn on the power of all equipment.
3.	The EUT will start to operate function.

Measurement Software			
No.	Description	Software	Version
1	Radiated Emission	EZ EMC	ATL-03A1-1

3.3. Configuration of Test System Details

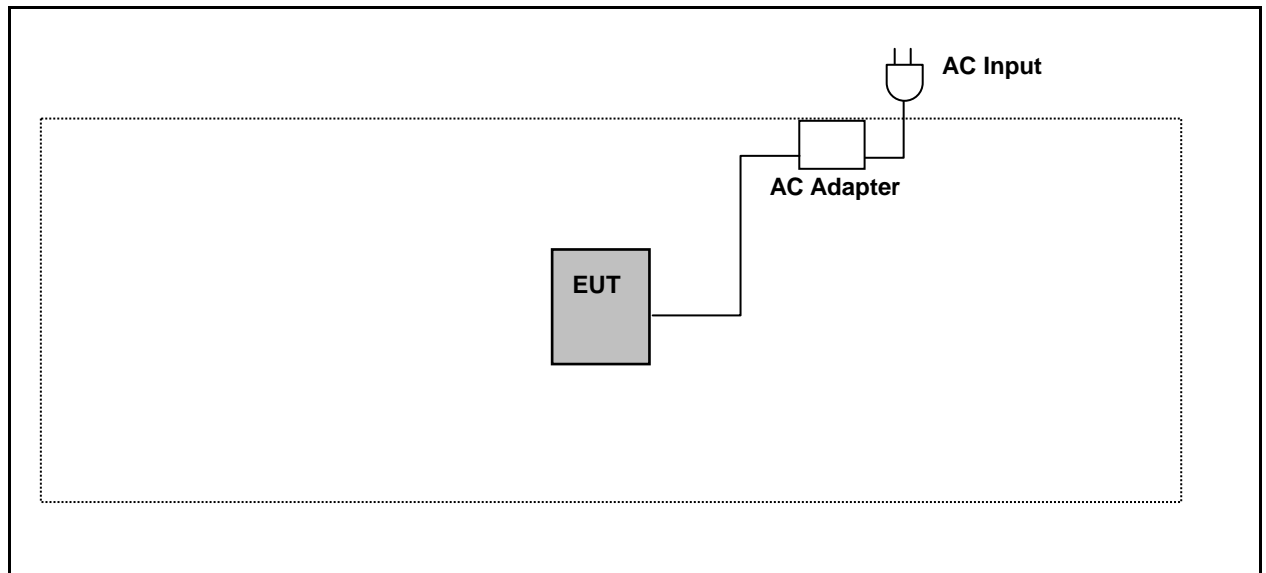

Devices Description					
	Product	Manufacturer	Model Number	Serial Number	Power Cord
(1)	---	---	---	---	---



3.4. Test Instruments

For Radiated Emissions

Test Period: Jul. 18, 2019

Equipment	Manufacturer	Model Number	Serial Number	Cal. Date	Cal. Period
Spectrum Analyzer (3Hz~43GHz)	Keysight	N9030A	MY55410268	09/18/2018	1 year
Preamplifier (0.1GHz~26.5GHz)	EMCI	EMC012645SE	980318	09/18/2018	1 year
Preamplifier (10kHz~3GHz)	EMCI	EMC001330	980300	09/18/2018	1 year
Bilog Antenna (30MHz~1.4GHz)	Schwarzbeck	VULB 9168	672	11/21/2018	1 year
Horn Antenna (1GHz~18GHz)	ETS	3117	00204949	11/16/2018	1 year
Loop Antenna	EMCI	LPA600	272	02/21/2019	1 year

For Conducted

Test Period: Jul. 18, 2019

Equipment	Manufacturer	Model Number	Serial Number	Cal. Date	Cal. Period
Spectrum Analyzer (10Hz~26.5GHz)	Agilent	N9020A	MY53420615	09/18/2018	1 year

3.5. Test Site Environment

Items	Required (IEC 60068-1)	Actual
Temperature (°C)	15-35	26
Humidity (%RH)	25-75	60
Barometric pressure (mbar)	860-1060	990

4 Measurement Procedure

4.1. AC Power Line Conducted Emission Measurement

■ Limit

Frequency (MHz)	Quasi-peak	Average
0.15 - 0.5	66 to 56	56 to 46
0.50 - 5.0	56	46
5.0 - 30.0	60	50

■ Test Setup

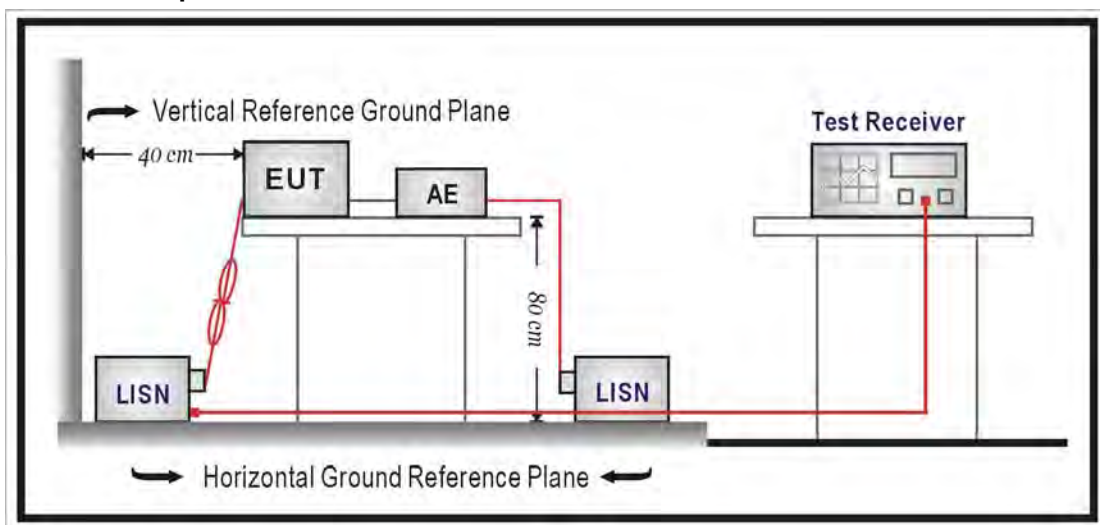

■ Test Procedure

The EUT and simulators are connected to the main power through a line impedance stabilization network (L.I.S.N.). This provides a $50 \Omega // 50 \mu\text{H}$ coupling impedance for the measuring equipment. The peripheral devices are also connected to the main power through a LISN that provides a $50 \Omega // 50 \mu\text{H}$ coupling impedance with 50 ohm termination.

Tabletop device shall be placed on a non-conducting platform, of nominal size 1 m by 1.5 m, raised 80 cm above the reference ground plane. The wall of screened room shall be located 40 cm to the rear of the EUT. Other surfaces of tabletop or floor standing EUT shall be at least 80 cm from any other ground conducting surface including one or more LISNs. For floor-standing device shall be placed under the EUT with a 12 mm insulating material.

Conducted emissions were investigated over the frequency range from 0.15 MHz to 30 MHz using a resolution bandwidth of 9 kHz. The equipment under test (EUT) shall be meet the limits in section 4.1, as applicable, including the average limit and the quasi-peak limit when using respectively, an average detector and quasi-peak detector measured in accordance with the methods described of related standard. When all of peak value were complied with quasi-peak and average limit from 150 kHz to 30 MHz then quasi-peak and average measurement was unnecessary.

The AMN shall be placed 0.8 m from the boundary of the unit under test and bonded to a ground reference plane for AMNs mounted on top of the ground reference plane. This distance is between the closest points of the AMN and the EUT. All other units of the EUT and associated equipment shall be at least 0.8 m from the AMN. If the mains power cable is longer than 1 m then the cable shall be folded back and forth at the centre of the lead to form a bundle no longer than 0.4 m. All of interconnecting cables that hang closer than 40 cm to the ground plane shall be folded back and forth in the center forming a bundle 30 cm to 40 cm long. All of EUT and AE shall be separate place more than 0.1 m. All 50 Ω ports of the LISN shall be resistively terminated into 50 Ω loads when not connected to the measuring instrument.

If the reading of the measuring receiver shows fluctuations close to the limit, the reading shall be observed for at least 15 s at each measurement frequency; the higher reading shall be recorded with the exception of any brief isolated high reading which shall be ignored..

4.2. Radiated Emissions Measurement

■ Limit

According to FCC Part 15.231(b) requirement:

In addition to the provisions of §15.205, the field strength of emissions from intentional radiator operated under this section shall not exceed the following:

Fundamental and harmonics emission limits

Frequency range (MHz)	Average Field Strength of Fundamental (dB μ V/m@3 m)	Peak Field Strength of Fundamental (dB μ V/m@3 m)
433.92	76.80	87.48

General Radiated emission Limit

Frequency range (MHz)	Field Strength of Fundamental (μ V/m at 3 m)	Field Strength of Harmonics (μ V/m at 3 m)
40.66 to 40.70	2250 (67.04 dBuV)	225 (47.04 dBuV)
70 to 130	1250 (61.94 dBuV)	125 (41.94 dBuV)
130 to 174	1250 (61.94 dBuV) to 3750 (71.48 dBuV)	125 (41.94 dBuV) to 375 (51.48 dBuV)
174 to 260	3750 (71.48 dBuV)	375 (51.48 dBuV)
260 to 470	3750 (71.48 dBuV) to 12500 (81.94 dBuV)	375 (51.48 dBuV) to 1250 (61.94 dBuV)
470 and above	12500 (81.94 dBuV)	1250 (61.94 dBuV)

Remark: 1. The table above tighter limit applies at the band edges.

2. The measurement distance in meters, which that between form closest point of EUT to instrument antenna.

■ **Setup**

Below 1 GHz

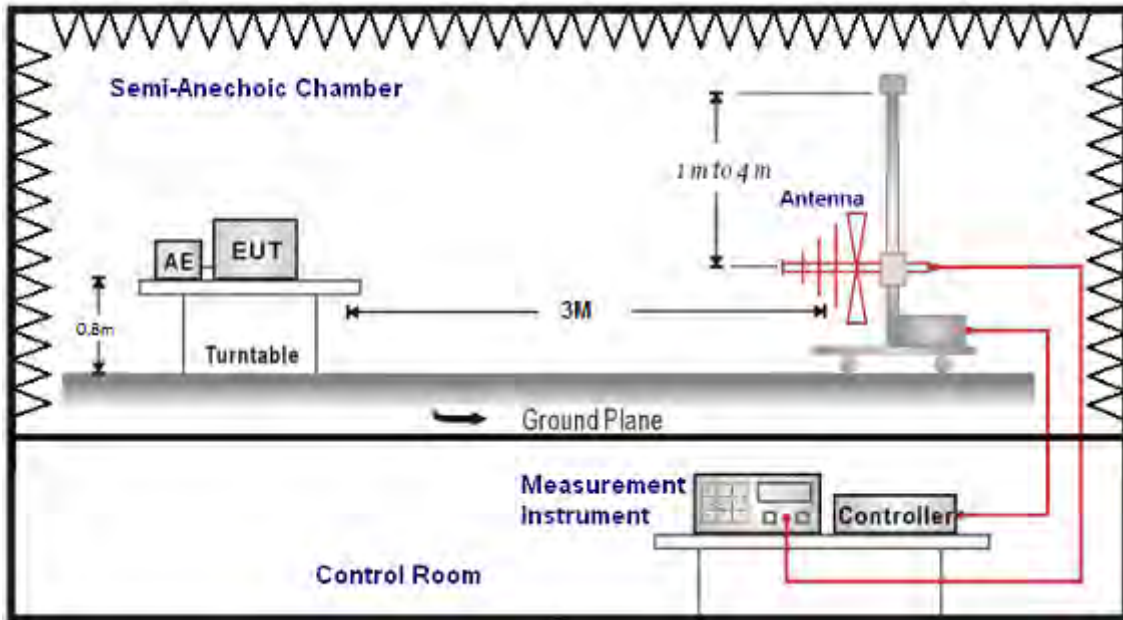

Above 1 GHz

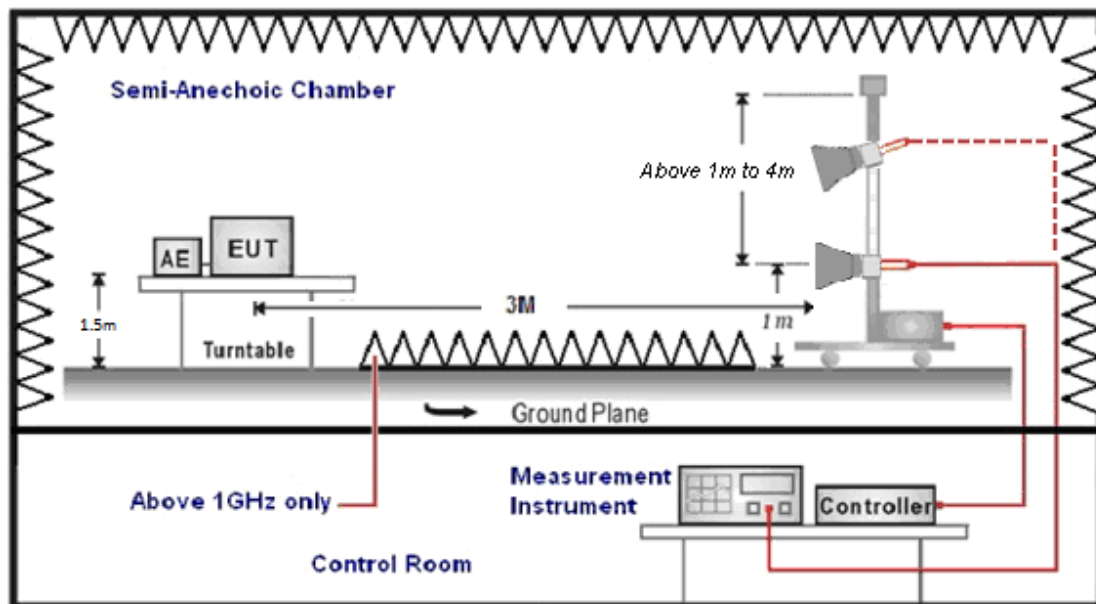

■ Test Procedure

Final radiation measurements were made on a three-meter, Semi Anechoic Chamber. The EUT system was placed on a nonconductive turntable which is 0.8 or 1.5 meters height, top surface 1.0 x 1.5 meter. The spectrum was examined from 250 MHz to 2.5 GHz in order to cover the whole spectrum below 10th harmonic which could generate from the EUT. During the test, EUT was set to transmit continuously & Measurements spectrum range from 30 MHz to 26.5 GHz is investigated.

For measurements below 1 GHz the resolution bandwidth is set to 100 kHz for peak detection measurements or 120 kHz for quasi-peak detection measurements. Peak detection is used unless otherwise noted as quasi-peak. For measurements above 1 GHz the resolution bandwidth is set to 1 MHz, and then the video bandwidth is set to 3 MHz for peak measurements and 10 Hz for average measurements.

A nonconductive material surrounded the EUT to supporting the EUT for standing on three orthogonal planes. At each condition, the EUT was rotated 360 degrees, and the antenna was raised and lowered from one to four meters to find the maximum emission levels. Measurements were taken using both horizontal and vertical antenna polarization.

SCHWARZBECK MESS-ELEKTRONIK Biconilog Antenna at 3 Meter and the SCHWARZBECK Double Ridged Guide Antenna was used in frequencies 1 – 26.5 GHz at a distance of 1 meter. All test results were extrapolated to equivalent signal at 3 meters utilizing an inverse linear distance extrapolation Factor (20 dB/decade).

For testing above 1 GHz, the emission level of the EUT in peak mode was 20 dB lower than average limit (that means the emission level in peak mode also complies with the limit in average mode), then testing will be stopped and peak values of EUT will be reported, otherwise, the emissions will be measured in average mode again and reported.

Appropriate preamplifiers were used for improving sensitivity and precautions were taken to avoid overloading or desensitizing the spectrum analyzer. No post – detector video filters were used in the test.

The spectrum analyzer's 6 dB bandwidth was set to 1 MHz, and the analyzer was operated in the peak detection mode, for frequencies both below and up 1 GHz. The average levels were obtained by subtracting the duty cycle correction factor from the peak readings.

The following procedures were used to convert the emission levels measured in decibels referenced to 1 microvolt (dBuV) into field intensity in micro volts pre meter (uV/m).

The actual field intensity in decibels referenced to 1 microvolt in to field intensity in micro volts per meter (dBuV/m).

The actual field intensity in referenced to 1 microvolt per meter (dBuV/m) is determined by algebraically adding the measured reading in dBuV, the antenna factor (dB), and cable loss (dB) and Subtracting the gain of preamplifier (dB) is auto calculate in spectrum analyzer.

$$(1) \text{ Amplitude (dBuV/m)} = \text{FI (dBuV)} + \text{AF (dBuV)} + \text{CL (dBuV)} - \text{Gain (dB)}$$

FI= Reading of the field intensity.

AF= Antenna factor.

CL= Cable loss.

P.S Amplitude is auto calculate in spectrum analyzer.

$$(2) \text{ Actual Amplitude (dBuV/m)} = \text{Amplitude (dBuV)} - \text{Dis(dB)}$$

The FCC specified emission limits were calculated according the EUT operating frequency and by following linear interpolation equations:

(a) For fundamental frequency : Transmitter Output < +30 dBm

(b) For spurious frequency : Spurious emission limits = fundamental emission limit /10

Data of measurement within this frequency range without mark in the table above means the reading of emissions are attenuated more than 20 dB below the permissible limits or the field strength is too small to be measured.

■ Calculation of Average Factor

The output field strengths of specification in accordance with the FCC rules specify measurements with an average detector. During the test, a spectrum analyzer incorporating a peak detector was used. Therefore, a reduction factor can be applied to the resultant peak signal level and compared to the limit for measurement instrumentation incorporating an average detector.

Please see the diagrams below.

(*) When the field strength (or envelope power) is not constant or when it is in pulses, and an averaging detector is specified to be used, the value of field strength or power over one complete pulse train, excluding blanking intervals, shall be averaged as long as the pulse train does not exceed 0.1 seconds. In cases where the pulse train exceeds 0.1 seconds, the average value (of field strength or output power) shall be determined during a 0.1 second interval during which the field strength or power is at its maximum value.

4.3. 20 dB Bandwidth Measurement

■ Limit

According to FCC Part 15.231(c) requirement:

The 20 dB

$$\text{B.W Limit} = 0.25 \% * f \text{ (MHz)} = 0.25 \% * 315 \text{ MHz} = 787.5 \text{ kHz}$$

■ Test Setup

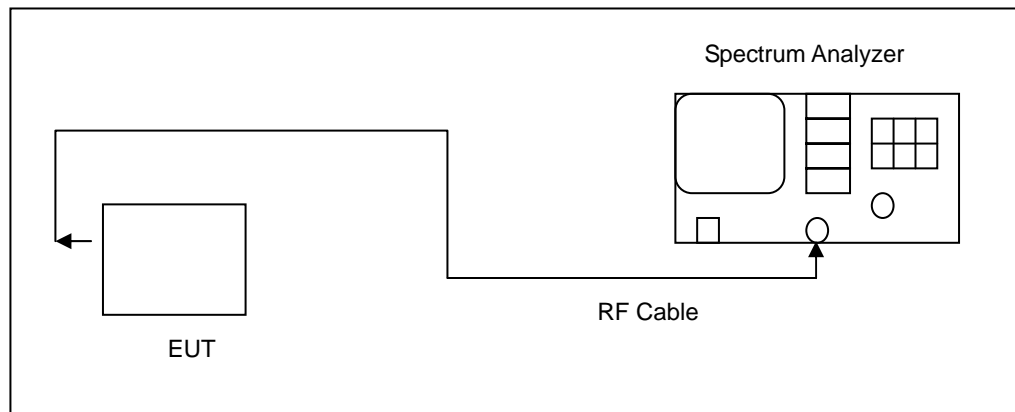

■ Test Procedure

The RF output port of the Equipment-Under-Test is directly coupled to the input of the analyzer through a specialized RF connector and a 10 dB passive attenuator. A fully charged battery was used for the supply voltage.

The RF function of the EUT was enabled. The spectrum analyzer used the following settings:

1. Span = 1 MHz
2. RBW \geq 1 % of the 20 dB span
3. VBW \geq RBW
4. Sweep = auto
5. Detector function = peak
6. Trace = max hold

The trace was allowed to stabilize. The EUT was transmitting at its maximum data rate. The marker-to-peak function was used to set the marker to the peak of the emission. The marker-delta function was used to measure 20 dB down one side of the emission. The marker-delta function and marker was moved to the other side of the emission until it was even with the reference marker. The marker-delta reading at this point was the 20 dB bandwidth of the emission.



4.4. Antenna Requirement

- **Limit**

For intentional device, according to 15.203, an intentional radiator shall be designed to ensure that no antenna other than that furnished by the responsible party shall be used with the device.

- **Antenna Connector Construction**

See section 2 – antenna information.



5 Test Results

Annex A. Conducted Emission

Standard:	FCC Part 15.231	Line:	L1
Test item:	Conducted Emission	Power:	AC 120 V/60 Hz
Mode:	Mode 1	Temp.(°C)/Hum.(%RH):	26(°C)/60 %RH
Description:			

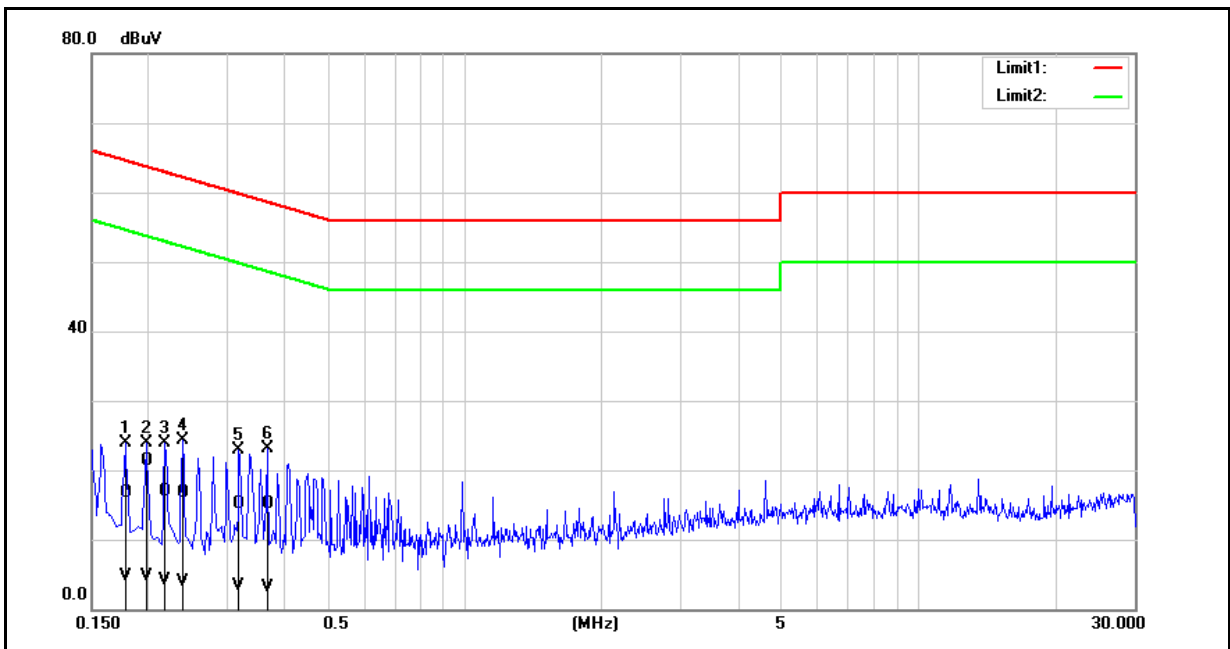

No.	Frequency (MHz)	QP reading (dBuV)	AVG reading (dBuV)	Correction factor (dB)	QP result (dBuV)	AVG result (dBuV)	QP limit (dBuV)	AVG limit (dBuV)	QP margin (dB)	AVG margin (dB)	Remark
1	0.1780	6.96	-4.88	9.65	16.61	4.77	64.58	54.58	-47.97	-49.81	Pass
2	0.1980	11.69	-4.89	9.66	21.35	4.77	63.69	53.69	-42.34	-48.92	Pass
3	0.2180	7.18	-5.56	9.66	16.84	4.10	62.89	52.89	-46.05	-48.79	Pass
4	0.2380	7.00	-5.67	9.65	16.65	3.98	62.17	52.17	-45.52	-48.19	Pass
5	0.3180	5.37	-6.41	9.66	15.03	3.25	59.76	49.76	-44.73	-46.51	Pass
6	0.3660	5.45	-6.56	9.67	15.12	3.11	58.59	48.59	-43.47	-45.48	Pass

Note: 1. Result (dBuV) = Correction factor (dB) + Reading(dBuV).

2. Correction factor (dB) = Cable loss (dB) + L.I.S.N. factor (dB).

Standard:	FCC Part 15.231	Line:	N
Test item:	Conducted Emission	Power:	AC 120 V/60 Hz
Mode:	Mode 1	Temp.(°C)/Hum.(%RH):	26(°C)/60 %RH
Description:			

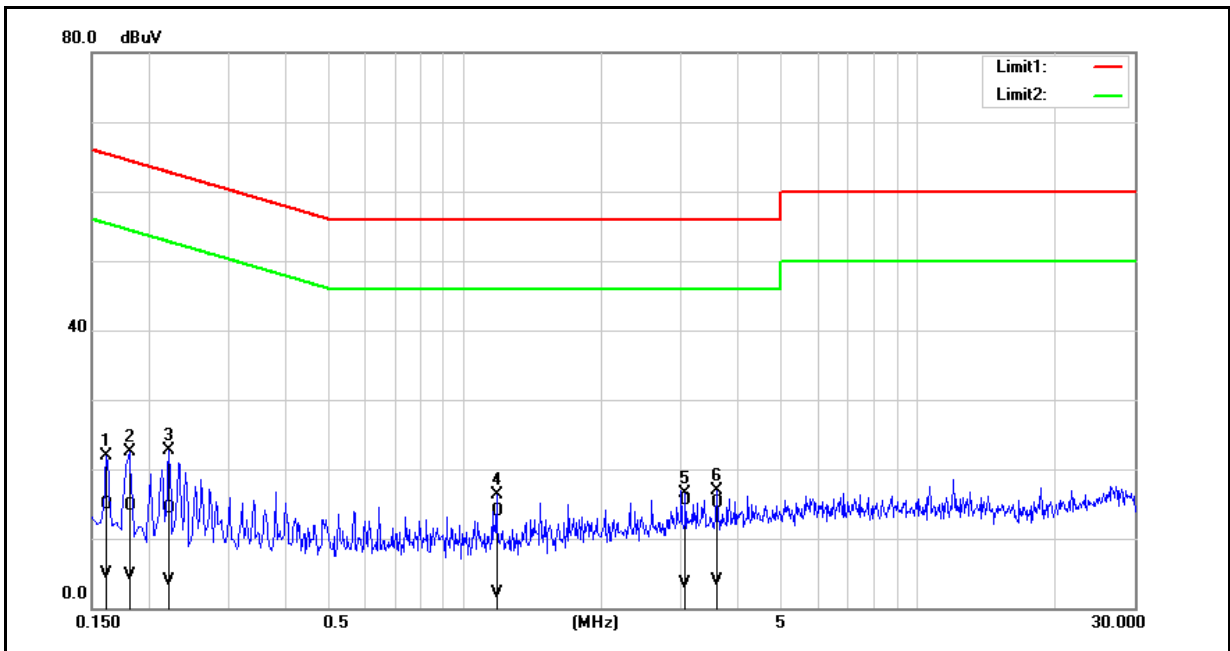

No.	Frequency (MHz)	QP reading (dBuV)	AVG reading (dBuV)	Correction factor (dB)	QP result (dBuV)	AVG result (dBuV)	QP limit (dBuV)	AVG limit (dBuV)	QP margin (dB)	AVG margin (dB)	Remark
1	0.1620	5.32	-4.69	9.68	15.00	4.99	65.36	55.36	-50.36	-50.37	Pass
2	0.1820	4.95	-4.96	9.68	14.63	4.72	64.39	54.39	-49.76	-49.67	Pass
3	0.2220	4.56	-5.81	9.69	14.25	3.88	62.74	52.74	-48.49	-48.86	Pass
4	1.1740	4.10	-7.74	9.80	13.90	2.06	56.00	46.00	-42.10	-43.94	Pass
5	3.0700	5.61	-6.31	9.88	15.49	3.57	56.00	46.00	-40.51	-42.43	Pass
6	3.5980	5.12	-6.02	9.90	15.02	3.88	56.00	46.00	-40.98	-42.12	Pass

Note: 1. Result (dBuV) = Correction factor (dB) + Reading(dBuV).
 2. Correction factor (dB) = Cable loss (dB) + L.I.S.N. factor (dB).

Annex B. Conducted Test Results

20 dB Bandwidth Measurement

Test Mode	Mode 2	
Frequency (MHz)	20 dB Bandwidth (kHz)	Limited (kHz)
433.906	7.942	1084.765

■ Test Graphs



Annex C. Radiated Emissions Measurement

Duty Cycle Test Diagrams

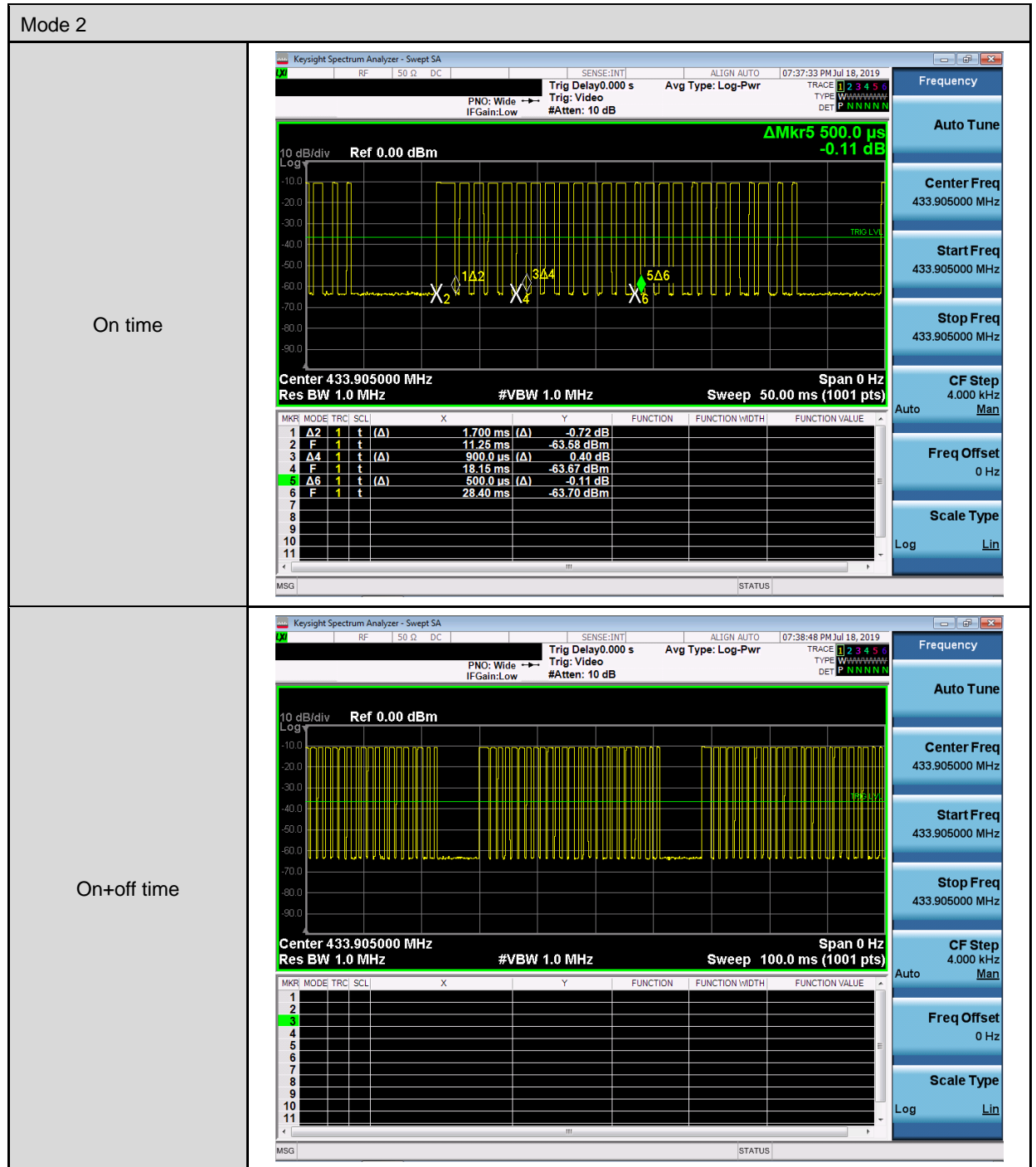

The EUT was complied with the requirement of FCC 15.231 (a) (1), which employed a switch that will automatically deactivate the transmitter within less than 5 seconds of being released.

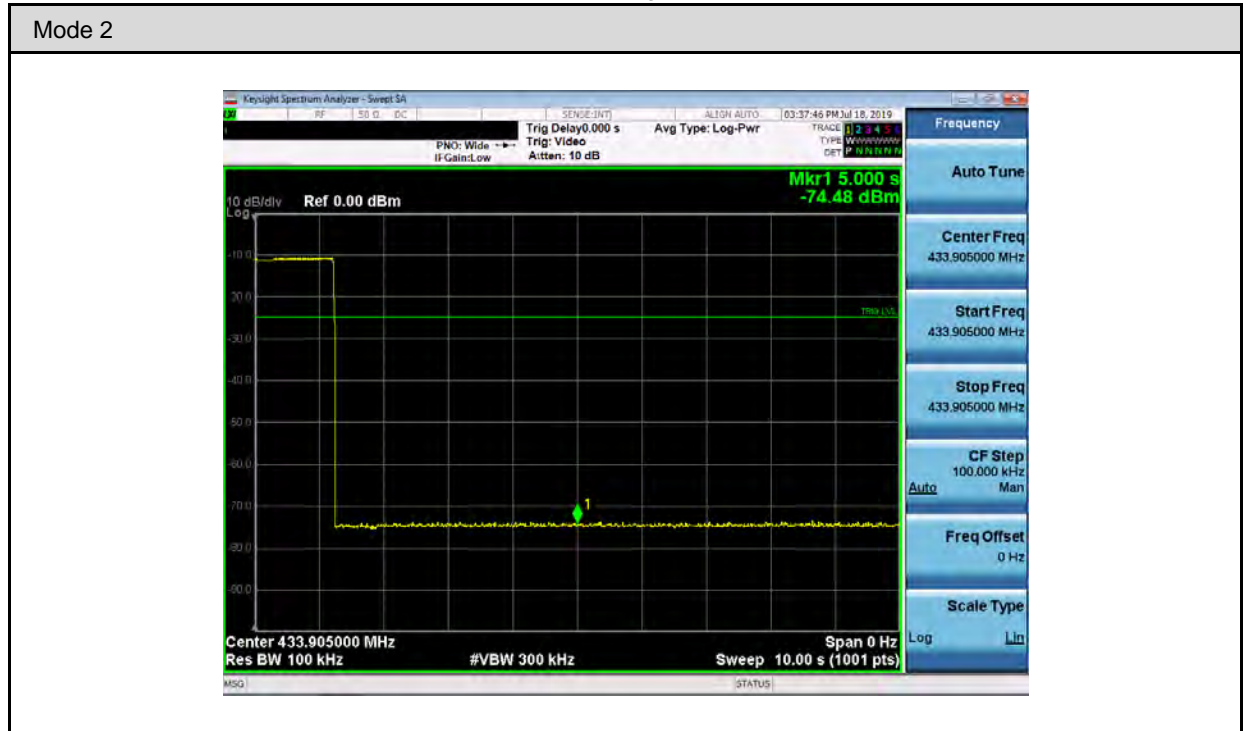

Duty Cycle Results

Test Mode	Mode 2		
Item	Results	Note	
Ton	36.25 ms	----	
Tp	100 ms	----	
Duty Cycle	0.3625	----	
Averaging Factor (20 log * Duty Cycle)	-8.81384	----	

Please see the diagrams below.

Note:

1. RB=100 kHz, VB=300 kHz, SPAN=0
2. Duty Cycle= Ton/Tp

**Fundamental Frequency Test Results**

Standard:	FCC Part 15.231	Test Distance:	3 m
Test item:	Fundamental	Power:	AC 120 V/60 Hz
Test Mode:	Mode 2	Temp.(°C)/Hum.(%RH):	26(°C)/60 %RH
Ant.Polar.:	Horizontal		

No.	Frequency (MHz)	Reading (dBuV)	Correct Factor (dB/m)	Result (dBuV/m)	Limit (dBuV/m)	Margin (dB)	Remark
1	433.9050	95.06	-7.58	87.48	100.83	-13.35	peak
2	433.9050	84.38	-7.58	76.80	80.83	-4.03	AVG

Note:1.Result (dBuV/m) = Correct Factor (dB/m) + Reading(dBuV).

Example: $100.83 = -7.58 + 95.06$

2.Correction factor (dB/m) = Antenna Factor (dB/m) + Cable loss (dB) – Pre-Amplifier gain (dB).

3.When the peak results are less than average limit, so not need to evaluate the average.

Standard:	FCC Part 15.231	Test Distance:	3 m
Test item:	Fundamental	Power:	AC 120 V/60 Hz
Test Mode:	Mode 2	Temp.(°C)/Hum.(%RH):	26(°C)/60 %RH
Ant.Polar.:	Vertical		

No.	Frequency (MHz)	Reading (dBuV)	Correct Factor (dB/m)	Result (dBuV/m)	Limit (dBuV/m)	Margin (dB)	Remark
1	433.9050	84.05	-7.58	76.47	100.83	-24.36	peak

Note:1.Result (dBuV/m) = Correct Factor (dB/m) + Reading(dBuV).

Example: $76.47 = -7.58 + 84.05$

2.Correction factor (dB/m) = Antenna Factor (dB/m) + Cable loss (dB) – Pre-Amplifier gain (dB).

3.When the peak results are less than average limit, so not need to evaluate the average.



Below 1 GHz

Standard:	FCC Part 15.231	Test Distance:	3 m				
Test item:	Harmonic	Power:	DC 4.5 V				
Test Mode:	Mode 1	Temp.(°C)/Hum.(%RH):	26(°C)/60 %RH				
Description:	Model Number : NGM-31						
Frequency (MHz)	Reading (dBuV)	Correct Factor (dB/m)	Result (dBuV/m)	Limit (dBuV/m)	Margin (dB)	Remark	Ant.Polar. H / V
161.9200	29.88	-11.37	18.51	43.50	-24.99	QP	H
430.6100	28.67	-7.67	21.00	46.00	-25.00	QP	H
571.2600	29.21	-4.41	24.80	46.00	-21.20	QP	H
709.0000	28.75	-2.42	26.33	46.00	-19.67	QP	H
773.0200	29.53	-1.18	28.35	46.00	-17.65	QP	H
977.6900	28.40	1.05	29.45	54.00	-24.55	QP	H
104.6900	38.28	-15.60	22.68	43.50	-20.82	QP	V
159.9800	29.74	-11.22	18.52	43.50	-24.98	QP	V
309.3600	29.46	-10.56	18.90	46.00	-27.10	QP	V
644.0100	29.42	-3.23	26.19	46.00	-19.81	QP	V
814.7300	28.84	-0.58	28.26	46.00	-17.74	QP	V
989.3300	28.61	1.16	29.77	54.00	-24.23	QP	V

Note:1.Result (dBuV/m) = Correct Factor (dB/m) + Reading(dBuV).

Example: 23.09=-8.31+31.40

2.Correction factor (dB/m) = Antenna Factor (dB/m) + Cable loss (dB) – Pre-Amplifier gain (dB).

3.When the peak results are less than average limit, so not need to evaluate the average.



Above 1 GHz

Standard:		FCC Part 15.231		Test Distance:		3 m	
Test item:		Harmonic		Power:		AC 120 V/60 Hz	
Test Mode:		Mode 2		Temp.(°C)/Hum.(%RH):		26(°C)/60 %RH	
Frequency (MHz)	Reading (dBUV)	Correct Factor (dB/m)	Result (dBUV/m)	Limit (dBUV/m)	Margin (dB)	Remark	Ant.Polar. H / V
1636.000	52.98	-14.55	38.43	74.00	-35.57	peak	H
2068.000	53.17	-10.75	42.42	74.00	-31.58	peak	H
2604.000	53.91	-9.28	44.63	74.00	-29.37	peak	H
3140.000	52.43	-7.88	44.55	74.00	-29.45	peak	H
3556.000	52.01	-7.16	44.85	74.00	-29.15	peak	V
4340.000	52.67	-5.59	47.08	74.00	-26.92	peak	V
1636.000	53.71	-14.55	39.16	74.00	-34.84	peak	V
2044.000	53.69	-10.81	42.88	74.00	-31.12	peak	V
2696.000	52.56	-8.95	43.61	74.00	-30.39	peak	V
3036.000	52.30	-8.06	44.24	74.00	-29.76	peak	V
3472.000	52.19	-7.38	44.81	74.00	-29.19	peak	V
4772.000	52.74	-5.04	47.70	74.00	-26.30	peak	V

Note:1.Result (dBUV/m) = Correct Factor (dB/m) + Reading(dBUV).

Example: 38.43=-14.55+52.98

2.Correction factor (dB/m) = Antenna Factor (dB/m) + Cable loss (dB) – Pre-Amplifier gain (dB).

3.When the peak results are less than average limit, so not need to evaluate the average.

**Band edge**

Standard:	FCC Part 15.231	Test Distance:	3 m				
Test item:	Band edge	Power:	AC 120 V/60 Hz				
Test Mode:	Mode 2	Temp.(°C)/Hum.(%RH):	26(°C)/60 %RH				
Frequency (MHz)	Reading (dBuV)	Correct Factor (dB/m)	Result (dBuV/m)	Limit (dBuV/m)	Margin (dB)	Remark	Ant.Polar. H / V
406.7212	31.40	-8.31	23.09	46.00	-22.91	QP	H
410.0000	31.23	-8.22	23.01	46.00	-22.99	QP	H
608.3200	27.96	-3.67	24.29	46.00	-21.71	QP	H
612.0448	27.94	-3.62	24.32	46.00	-21.68	QP	H
401.2044	29.79	-8.46	21.33	46.00	-24.67	QP	V
410.0000	31.67	-8.22	23.45	46.00	-22.55	QP	V
600.5950	26.43	-3.76	22.67	46.00	-23.33	QP	V
605.5950	26.44	-3.70	22.74	46.00	-23.26	QP	V

Note:1.Result (dBuV/m) = Correct Factor (dB/m) + Reading(dBuV).

2.Correction factor (dB/m) = Antenna Factor (dB/m) + Cable loss (dB) – Pre-Amplifier gain (dB).

3.When the peak results are less than average limit, so not need to evaluate the average.

--- END---