

FCC - TEST REPORT

Report Number : **68.950.23.0880.01** Date of Issue: **2023-11-06**

Model : **NPG-001, HP52A, HP52AX, NPG01ASTB**

Product : **Playground**

Applicant : **Shenzhen Skyworth Digital Technology Co., LTD.**

Address : **14/F, Unit A, Skyworth Building, Gaoxin Ave.1.S.,**

Nanshan District, 518063 Shenzhen,

PEOPLE'S REPUBLIC OF CHINA

Manufacturer : **Shenzhen Skyworth Digital Technology Co., LTD.**

Address : **14/F, Unit A, Skyworth Building, Gaoxin Ave.1.S.,**

Nanshan District, 518063 Shenzhen,

PEOPLE'S REPUBLIC OF CHINA

Test Result : **Positive** Negative

Total pages including Appendices : **41**

Any use for advertising purposes must be granted in writing. This technical report may only be quoted in full. This report is the result of a single examination of the object in question and is not generally applicable evaluation of the quality of other products in regular production. For further details, please see testing and certification regulation, chapter A-3.4.



1 Table of Contents

1	Table of Contents	2
2	Details about the Test Laboratory	3
3	Description of the Equipment Under Test	4
4	Summary of Test Standards	5
5	Summary of Test Results	6
6	General Remarks	7
7	Test Setups	8
8	Systems Test Configuration	10
9	Technical Requirement	11
9.1	Conducted Emission	11
9.2	Conducted Peak Output Power	14
9.3	Power Spectral Density	18
9.4	6 dB Bandwidth	21
9.5	Spurious RF Conducted Emissions	24
9.6	Band Edge.....	32
9.7	Spurious Radiated Emissions for Transmitter.....	35
10	Test Equipment List.....	40
11	System Measurement Uncertainty	41

2 Details about the Test Laboratory

Details about the Test Laboratory

Test Site 1

Company name: TÜV SÜD Certification and Testing (China) Co., Ltd. Shenzhen Branch
Building 12 & 13, Zhiheng Wisdomland Business Park, Guankou Erlu,
Nantou, Nanshan District
Shenzhen 518052
P.R. China

Telephone: 86 755 8828 6998

Fax: 86 755 8828 5299

FCC Registration No.: 514049

FCC Designation Number: CA5009

IC Registration No.: 10320A

3 Description of the Equipment Under Test

Product:	Playground
Model no.:	NPG-001, HP52A, HP52AX, NPG01ASTB
Model difference:	All models have the same technical construction including circuit diagram, PCB layout, components and component layout. Only the outlook/color are different. So the main test model is NPG-001.
FCC ID:	WNA-NPG-001
Rating:	5VDC, 3A supplied by external adapter
Options and accessories:	Adapter, HDMI Cable, Remote
Adapter information:	Adapter Model: AD-0150500300US-1 Input: 100-240VAC 50/60Hz, 0.5A, Output: 5VDC,3.0A 15.0W
Remote information:	Type name: Bluetooth voice remote control Model: NPG-RCU-001 FCC ID: 2A7GQ-NPG-RCU-001
RF Transmission Frequency:	2402MHz-2480MHz
No. of Operated Channel:	40
Modulation:	GFSK
Antenna Type:	On Board antenna
Antenna Gain:	1.87dBi
Description of the EUT:	The EUT is a playground with Bluetooth Low Energy/Bluetooth BDR+EDR, 2.4G Wi-Fi & 5G Wi-Fi functions.

Only Bluetooth Low Energy included in this report.

NOTE: The above EUT's information is declared by manufacturer. Please refer to the specifications or user's manual for more detailed description.

4 Summary of Test Standards

Test Standards	
FCC Part 15 Subpart C 10-1-2021 Edition	PART 15 - RADIO FREQUENCY DEVICES Subpart C - Intentional Radiators

All the test methods were according to KDB 558074 D01 15.247 Meas Guidance v05r02 Measurement Guidance and ANSI C63.10 (2020).

5 Summary of Test Results

Technical Requirements			
FCC Part 15 Subpart C 10-1-2021 Edition			
Test Condition		Test Result	Test Site
§15.207	Conducted emission AC power port	Pass	Site 1
§15.247 (b) (3)	Conducted output power	Pass	Site 1
§15.247(e)	Power spectral density	Pass	Site 1
§15.247(a)(2)	6dB bandwidth	Pass	Site 1
§15.247(a)(1)	20dB Occupied bandwidth	N/A	--
§15.247(a)(1)	Carrier frequency separation	N/A	--
§15.247(a)(1)(iii)	Number of hopping frequencies	N/A	--
§15.247(a)(1)(iii)	Dwell Time	N/A	--
§15.247(d)	Spurious RF conducted emissions	Pass	Site 1
§15.247(d)	Band edge	Pass	Site 1
§15.247(d) & §15.205 & §15.209	Spurious radiated emissions for transmitter	Pass	Site 1
§15.203	Antenna requirement	Pass See note 1	--

Note 1: N/A=Not Applicable.

Note 2: The EUT uses on board antenna, which gain is 1.87dBi. In accordance to §15.203, it is considered sufficiently to comply with the provisions of this section.

6 General Remarks

Remarks

This submittal(s) (test report) is intended for FCC ID: WNA-NPG-001 complies with Section 15.207, 15.209, 15.247 of the FCC Part 15, Subpart C rules.

SUMMARY:

All tests according to the regulations cited on page 5 were

- Performed

- **Not** Performed

The Equipment under Test

- **Fulfills** the general approval requirements.

- **Does not** fulfill the general approval requirements.

Sample Received Date: 2023-10-23

Testing Start Date: 2023-10-23

Testing End Date: 2023-11-02

- TÜV SÜD Certification and Testing (China) Co., Ltd. Shenzhen Branch -

Reviewed by:

Prepared by:

Tested by:

John Zhi
Project Manager



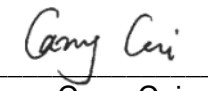

Sanvin Zheng
Project Engineer

Carry Cai
Test Engineer

7 Test Setups

7.1 Radiated test setups

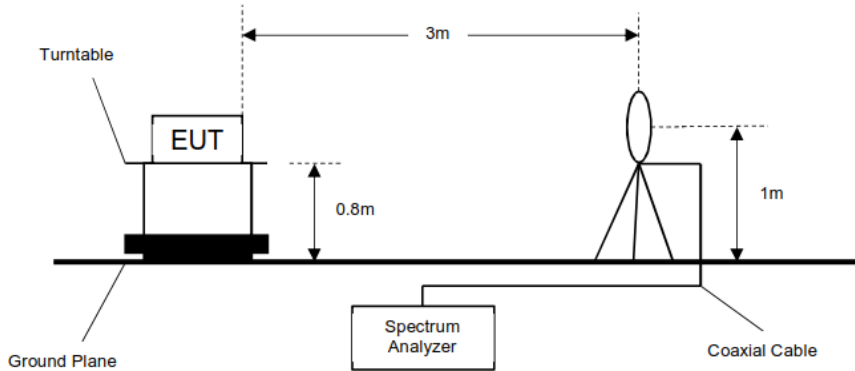
9kHz - 30MHz



30MHz - 1GHz

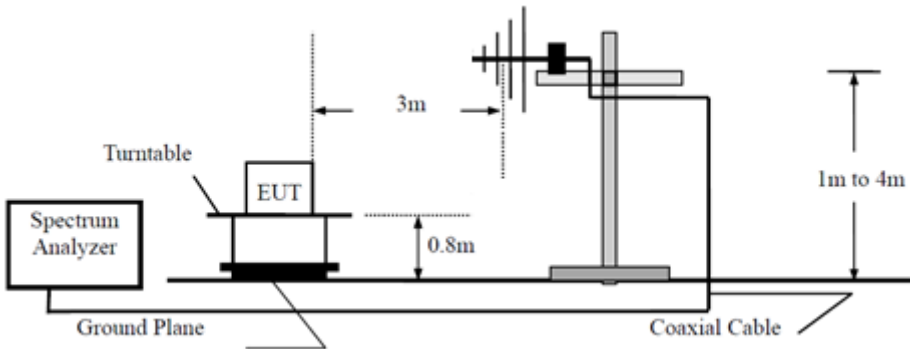

Above 1GHz

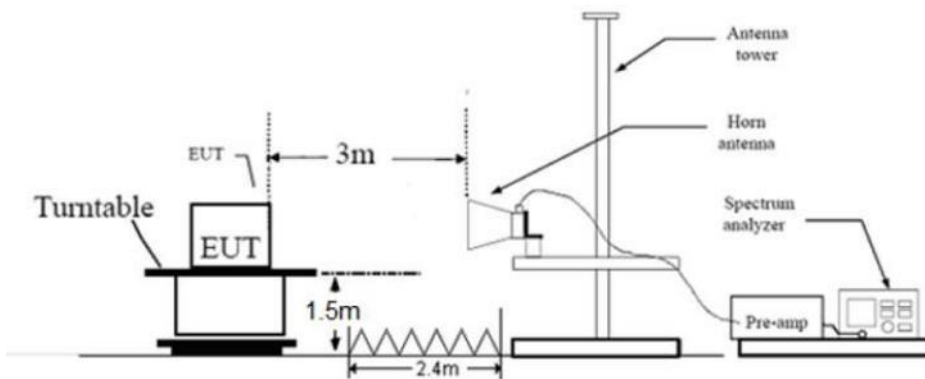

7.2 Conducted RF test setups

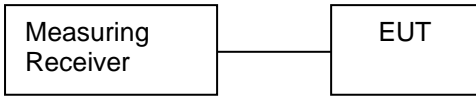

7.3 AC Power Line Conducted Emission test setups

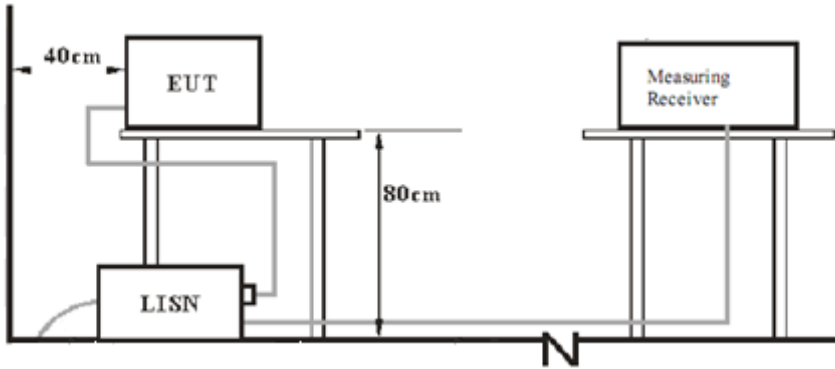

8 Systems Test Configuration

Auxiliary Equipment Used during Test:

Description	Manufacturer	Model No.	Remark
Notebook	Lenovo	X220	---
Remote	Wuxi Weida Intelligent Electronics	NPG-RCU-001	Type name: Bluetooth voice remote control FCC ID: 2A7GQ-NPG-RCU-001

Cables Used During Test:

Cable	Length	Shielded/unshielded	With / without ferrite
HDMI Cable	150cm	Shielded	Without ferrite
Type-C Cable	100cm	Unshielded	Without ferrite

Test software information:

Test Software	adb.exe	
Modulation	Setting TX Power	Packet Type
GFSK	Default	PRBS9

The system was configured to non-hopping mode, testing channel 0, 19, 39.

9 Technical Requirement

9.1 Conducted Emission

Test Method

1. The EUT was placed 0.4 meter from the conducting wall of the shielding room was kept at least 80 centimeters from any other grounded conducting surface.
2. Connect EUT to the power mains through a line impedance stabilization network (LISN).
3. All the support units are connecting to the other LISN.
4. The LISN provides 50 ohm coupling impedance for the measuring instrument.
5. Both sides of AC line were checked for maximum conducted interference.
6. The frequency range from 150 kHz to 30 MHz was searched.
7. Set the test-receiver system to Peak Detect Function and specified bandwidth (IF Bandwidth = 9kHz) with Maximum Hold Mode. Then measurement is also conducted by Average Detector and Quasi-Peak Detector Function respectively.

Limit

According to §15.207, conducted emissions limit as below:

Frequency MHz	QP Limit dB μ V	AV Limit dB μ V
0.150-0.500	66-56*	56-46*
0.500-5	56	46
5-30	60	50

*Decreasing linearly with logarithm of the frequency

Conducted Emission

Product Type : Playground
 M/N : NPG-001
 Operating Condition : Transmitting mode
 Test Specification : Line
 Comment : AC 120V/60Hz

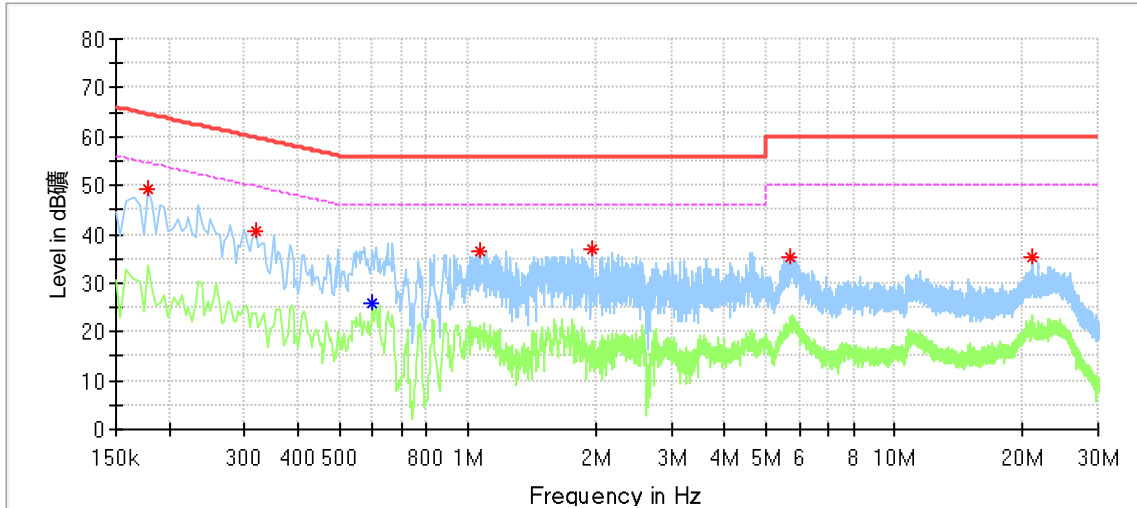

Frequency (MHz)	MaxPeak (dBµV)	Average (dBµV)	Limit (dBµV)	Margin (dB)	Line	Corr. (dB)
0.178000	49.04	---	64.58	15.54	L1	9.54
0.318000	40.79	---	59.76	18.96	L1	9.57
0.598000	---	25.82	46.00	20.18	L1	9.60
1.066000	36.60	---	56.00	19.40	L1	9.60
1.958000	37.03	---	56.00	18.97	L1	9.61
5.682000	35.20	---	60.00	24.80	L1	9.78
20.962000	35.23	---	60.00	24.77	L1	10.03

Remark:
 Max Peak=Reading Level + Correction Factor
 Correction Factor=Cable Loss + LISN Factor
 (The Reading Level is recorded by software which is not shown in the sheet)

Conducted Emission

Product Type : Playground
 M/N : NPG-001
 Operating Condition : Transmitting mode
 Test Specification : Neutral
 Comment : AC 120V/60Hz

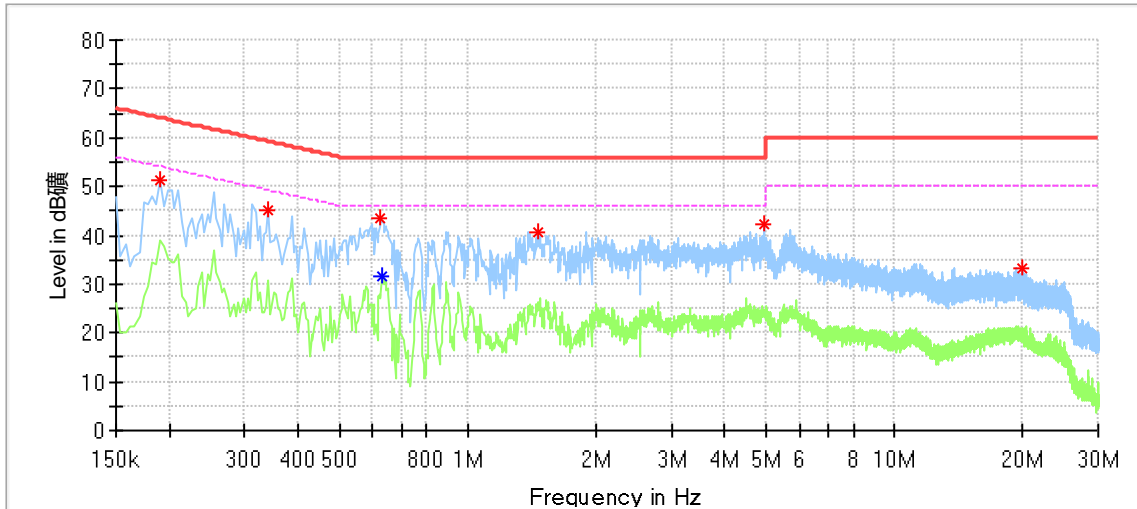

Frequency (MHz)	MaxPeak (dBµV)	Average (dBµV)	Limit (dBµV)	Margin (dB)	Line	Corr. (dB)
0.190000	51.41	---	64.04	12.63	N	9.57
0.342000	45.10	---	59.16	14.05	N	9.61
0.626000	43.38	---	56.00	12.62	N	9.63
0.630000	---	31.57	46.00	14.43	N	9.63
1.458000	40.59	---	56.00	15.41	N	9.64
4.950000	42.28	---	56.00	13.72	N	9.77
20.006000	33.28	---	60.00	26.72	N	9.95

Remark:
 Max Peak=Reading Level + Correction Factor
 Correction Factor=Cable Loss + LISN Factor
 (The Reading Level is recorded by software which is not shown in the sheet)

9.2 Conducted Peak Output Power

Test Method

1. The EUT was placed on 0.8m height table, the RF output of EUT was connected to the spectrum analyzer by RF cable. The path loss was compensated to the results for each measurement.
2. Set to the maximum power setting and enable the EUT transmit continuously.
3. Use the following test receiver settings:
Span = approximately 5 times the 20dB bandwidth, centered on a hopping channel
RBW > the 20dB bandwidth of the emission being measured, VBW \geq RBW,
Sweep = auto, Detector function = peak, Trace = max hold
4. Allow the trace to stabilize. Use the marker-to-peak function to set the marker to the peak of the emission. The indicated level is the peak output power and record the results in the test report.
5. Repeat above procedures until all frequencies measured were complete.

Limits

According to §15.247 (b) (3), conducted output power limit as below:

Frequency Range MHz	Limit W	Limit dBm
2400-2483.5	≤ 1	≤ 30

Conducted Peak Output Power

Frequency MHz	Mode	Conducted Peak Output Power dBm	Result
Bottom channel 2402MHz	LE 1M	6.18	Pass
Middle channel 2440MHz	LE 1M	5.89	Pass
Top channel 2480MHz	LE 1M	5.71	Pass
Bottom channel 2402MHz	LE 2M	6.21	Pass
Middle channel 2440MHz	LE 2M	5.89	Pass
Top channel 2480MHz	LE 2M	5.82	Pass

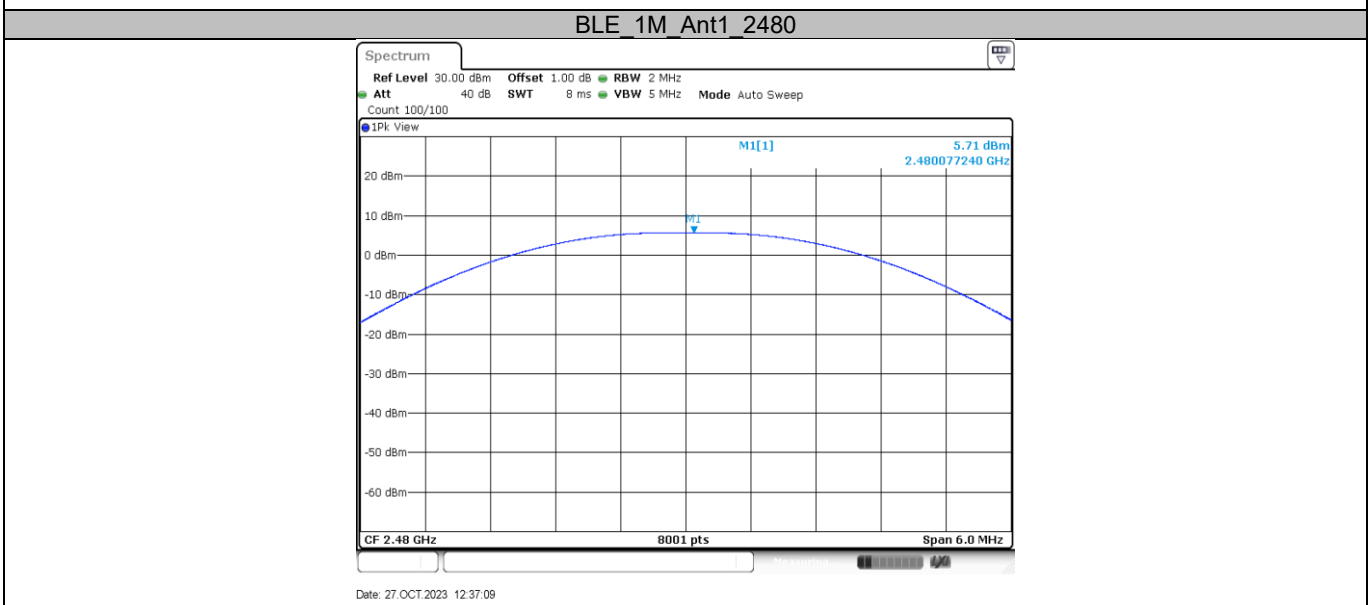
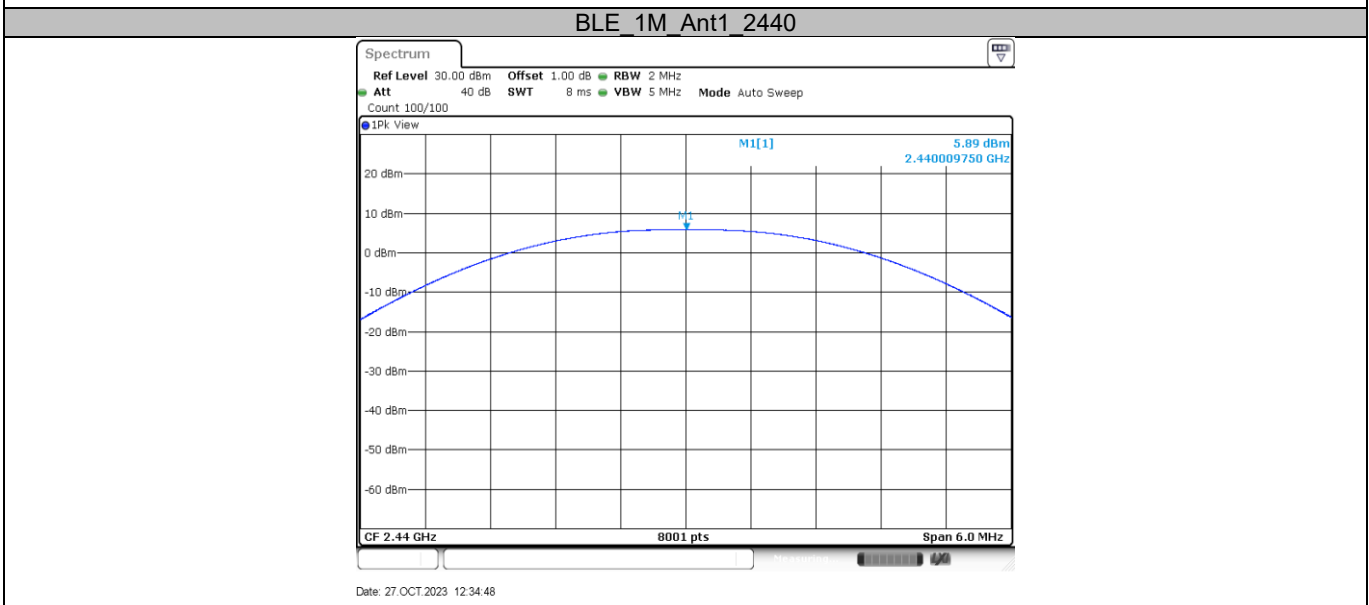
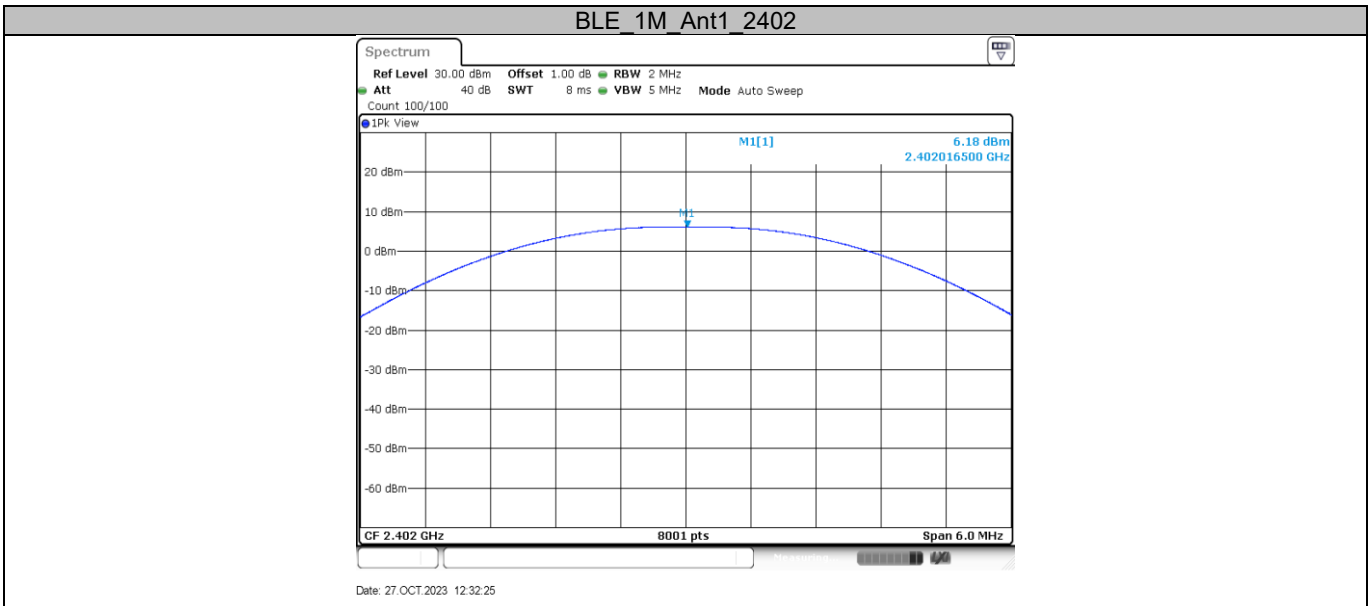

BLE_2M_Ant1_2402

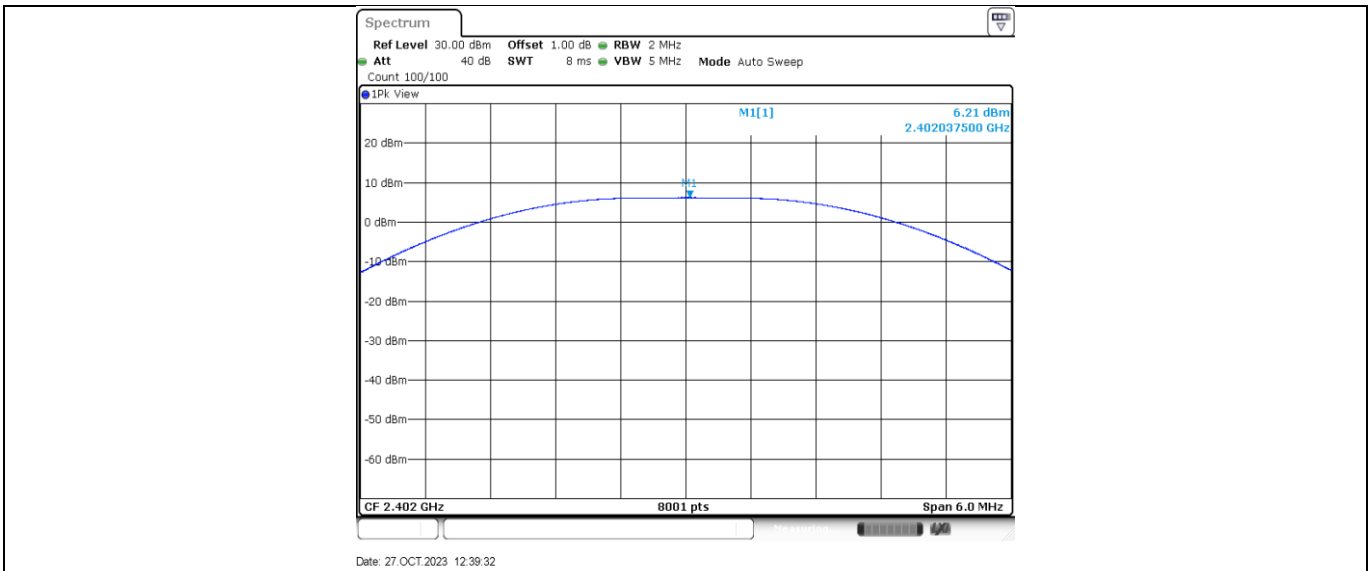

BLE 2M Ant1_2440

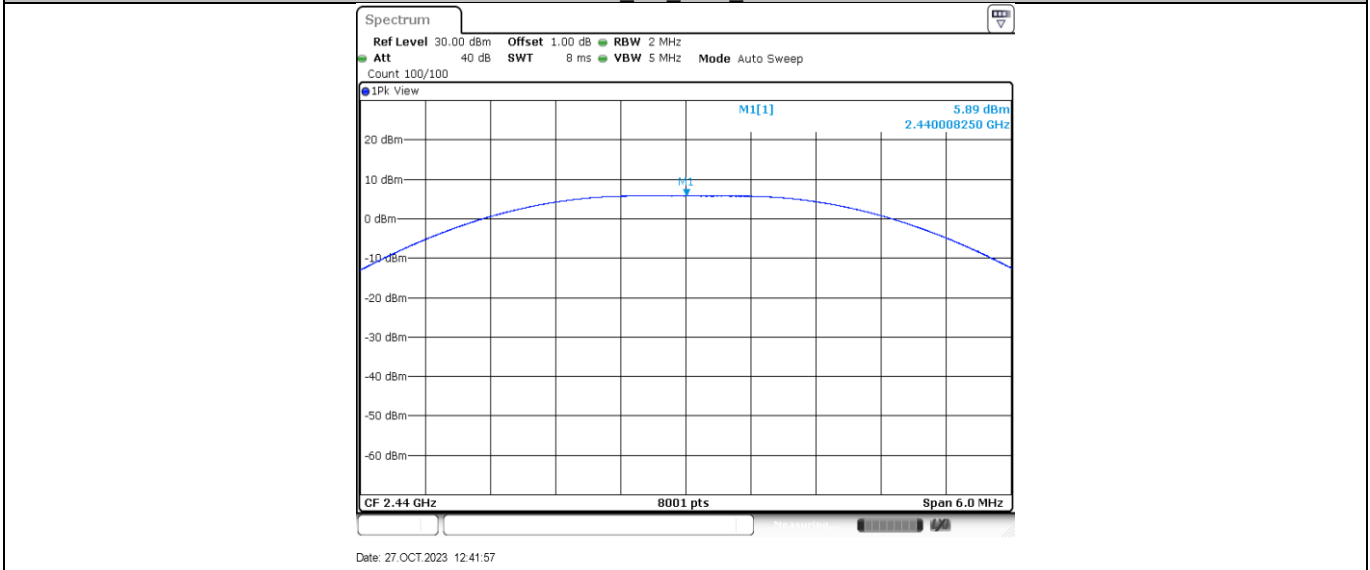

BLE 2M Ant1_2480

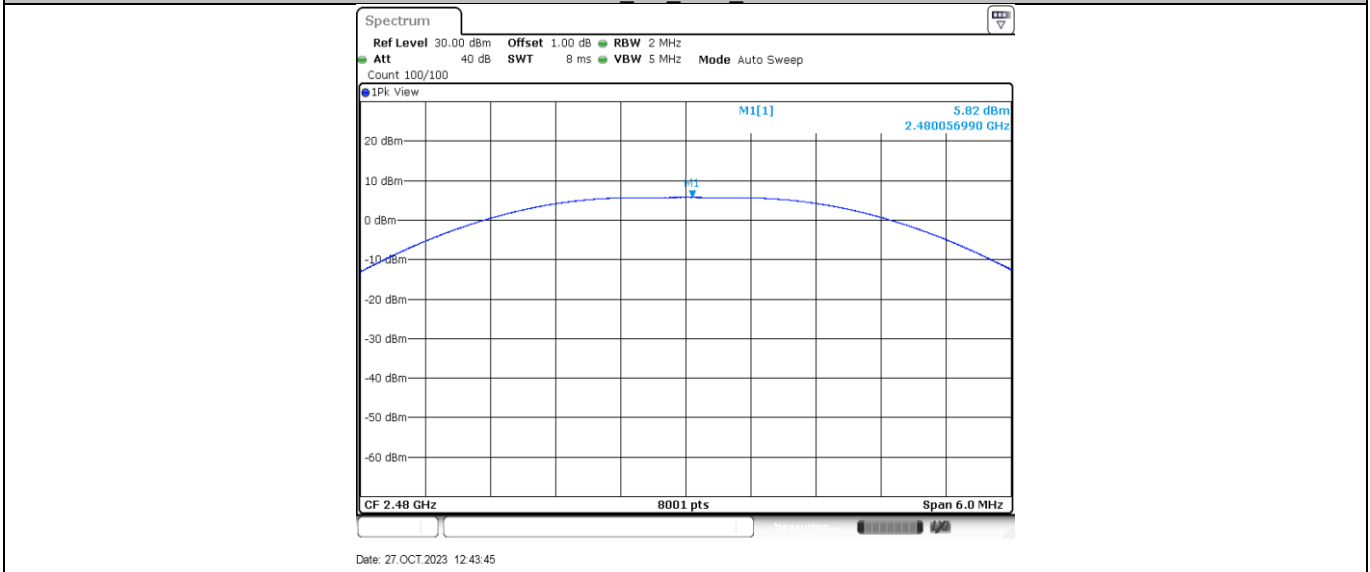

9.3 Power Spectral Density

Test Method

This procedure shall be used if maximum peak conducted output power was used to demonstrate compliance:

1. The RF output of EUT was connected to the spectrum analyzer. The path loss was compensated to the results for each measurement.
2. Set to the maximum power setting, the instrument center frequency is set to the nominal EUT channel center frequency enable the EUT transmit continuously.
3. Use the following spectrum analyzer settings:
4. Set analyzer center frequency to DTS channel center frequency. RBW=3kHz, VBW \geq 3RBW, Span=1.5 times DTS bandwidth, Detector=Peak, Sweep=auto, Trace= max hold.
5. Allow trace to fully stabilize, use the peak marker function to determine the maximum amplitude level within the RBW.
6. Repeat above procedures until other frequencies measured were completed.

Limit

According to §15.247(e), power spectral density limit as below:

Limit [dBm]

≤8

Test result

Frequency MHz	Mode	Power spectral density dBm/3kHz	Result
Bottom channel 2402MHz	LE 1M	-9.14	Pass
Middle channel 2440MHz	LE 1M	-9.39	Pass
Top channel 2480MHz	LE 1M	-9.39	Pass
Bottom channel 2402MHz	LE 2M	-10.20	Pass
Middle channel 2440MHz	LE 2M	-10.51	Pass
Top channel 2480MHz	LE 2M	-10.50	Pass

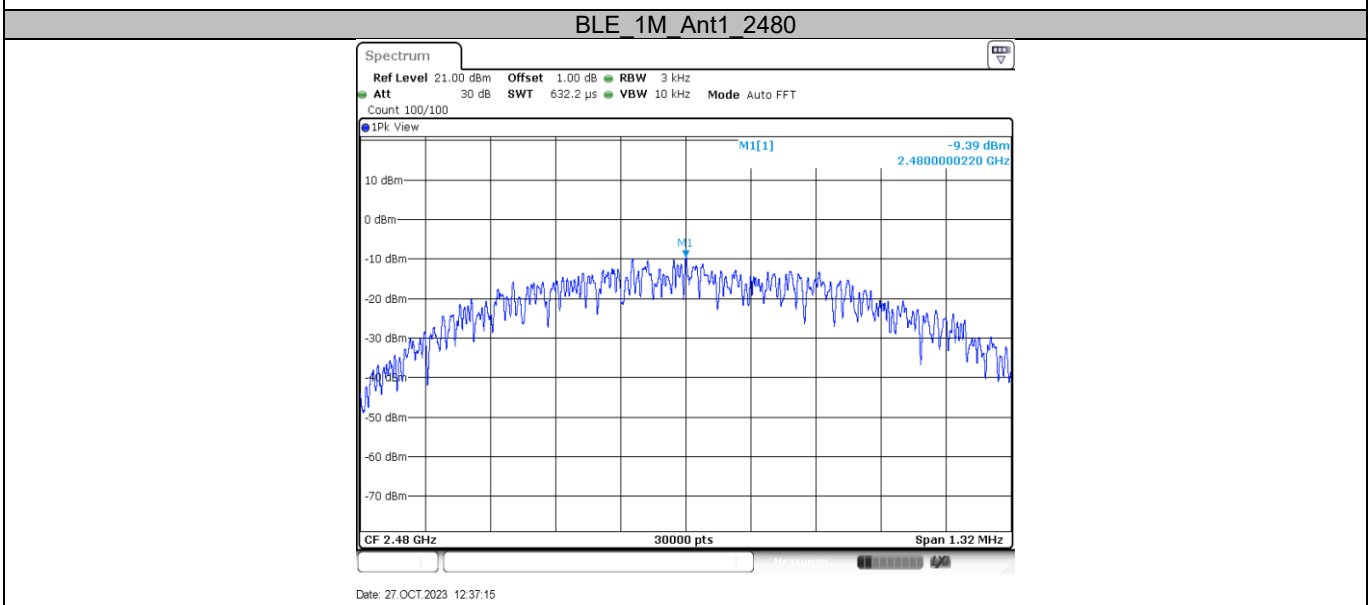
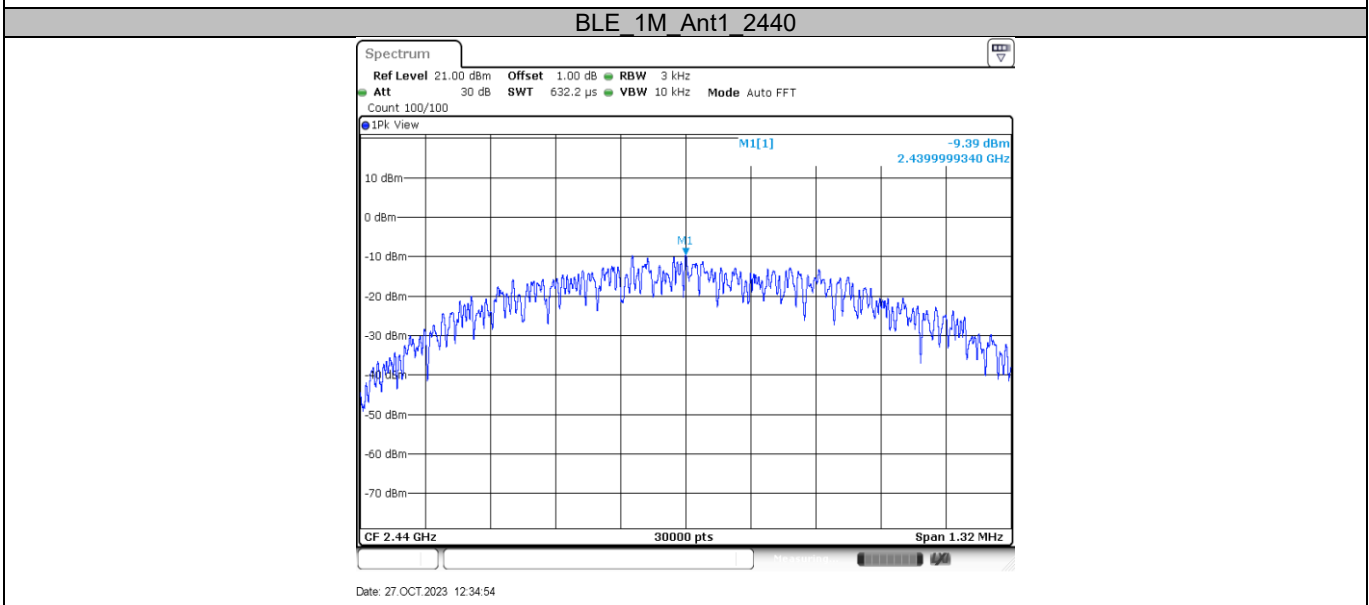
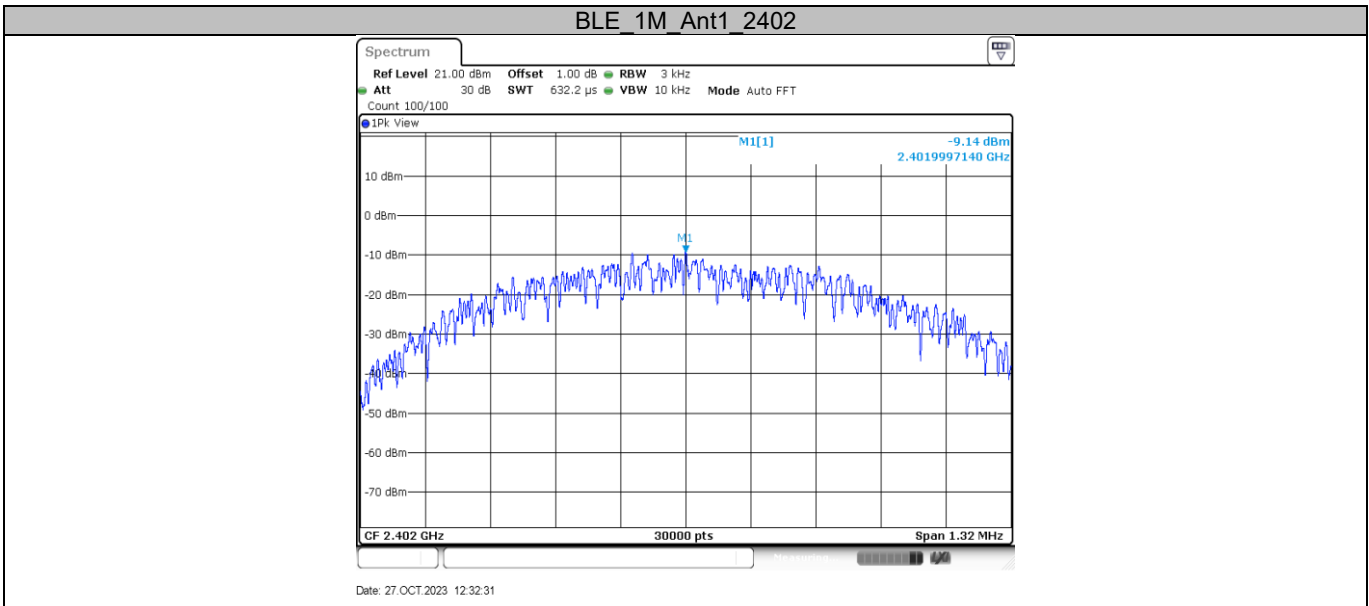

BLE_2M_Ant1_2402

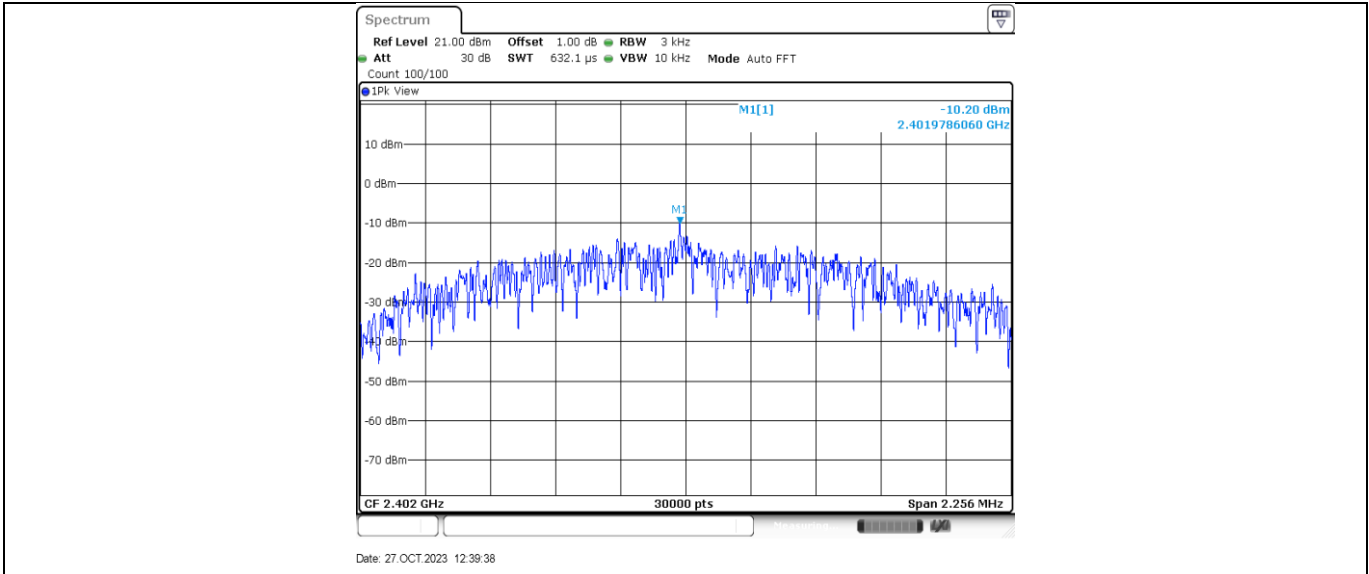

BLE 2M Ant1_2440

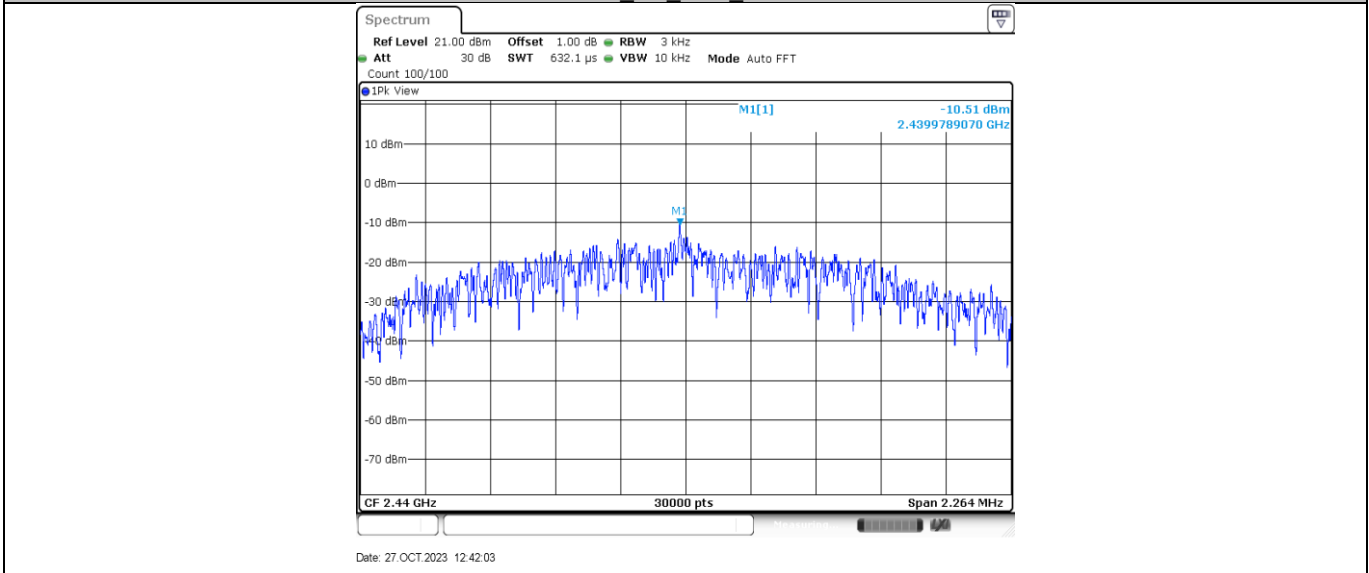

BLE 2M Ant1_2480

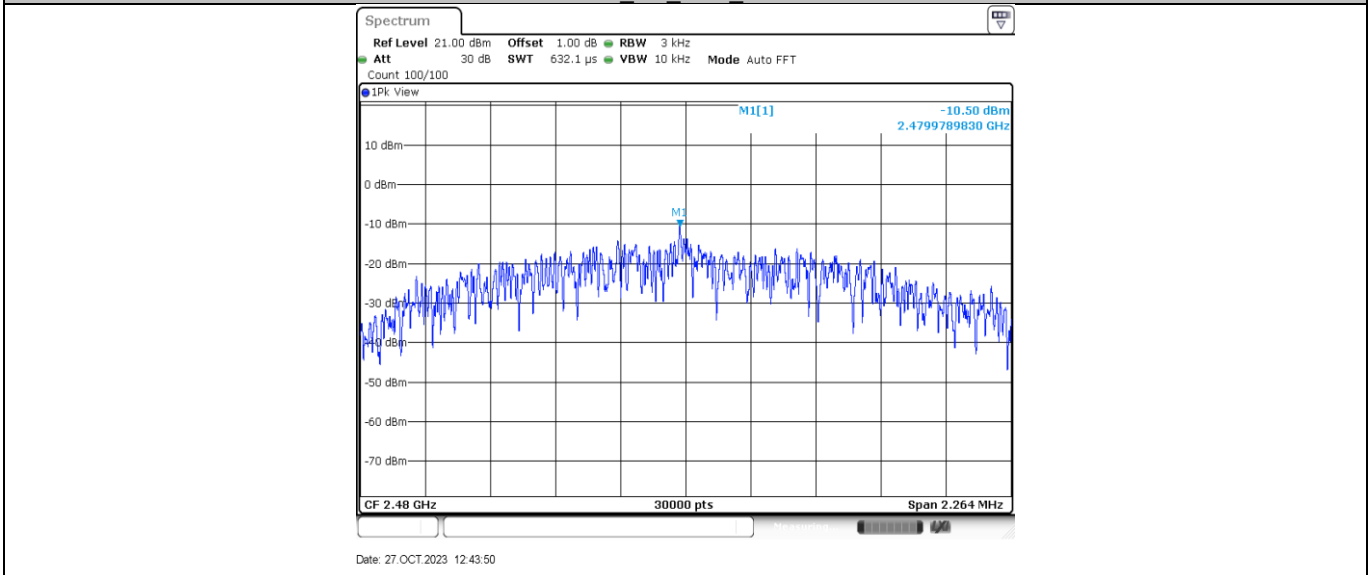

9.4 6 dB Bandwidth

Test Method

1. The RF output of EUT was connected to the spectrum analyzer. The path loss was compensated to the results for each measurement.
2. Set to the maximum power setting, the instrument center frequency is set to the nominal EUT channel center frequency enable the EUT transmit continuously.
3. Use the following spectrum analyzer settings:
RBW=100KHz, VBW≥3RBW, Sweep = auto, Detector function = peak, Trace = max hold
4. Use the automatic bandwidth measurement capability of an instrument, use the X dB bandwidth mode with X set to 6 dB.
5. Allow the trace to stabilize, record the 6 dB Bandwidth value.

Limit

According to §15.247(a)(2), 6 dB bandwidth limit as below:

Limit [kHz]

≥500

Test result

Frequency MHz	Mode	6dB bandwidth MHz	Result
Bottom channel 2402MHz	LE 1M	0.660	Pass
Middle channel 2440MHz	LE 1M	0.660	Pass
Top channel 2480MHz	LE 1M	0.660	Pass
Bottom channel 2402MHz	LE 2M	1.128	Pass
Middle channel 2440MHz	LE 2M	1.132	Pass
Top channel 2480MHz	LE 2M	1.132	Pass

Test Graphs

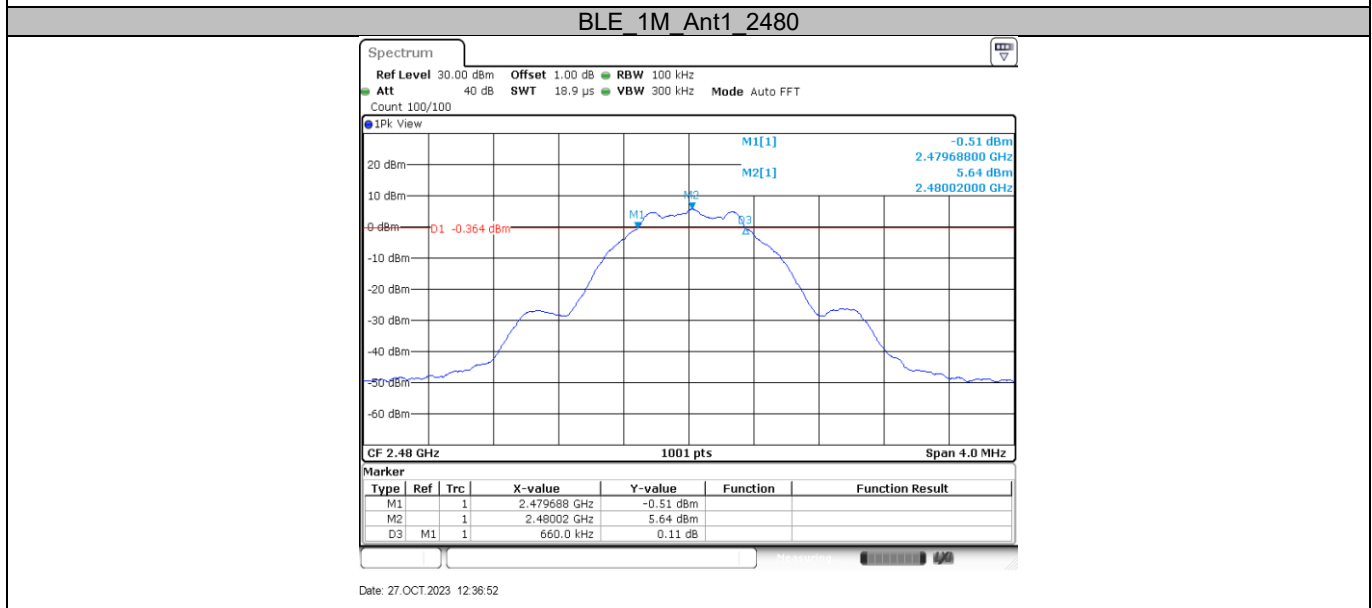
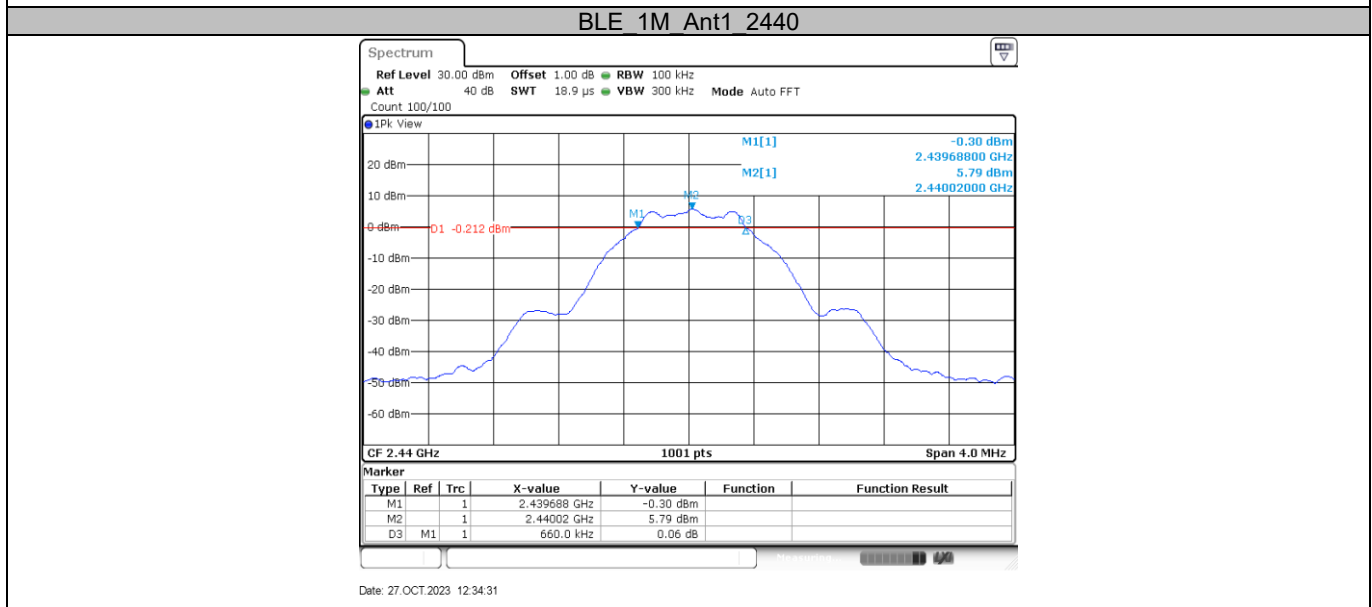
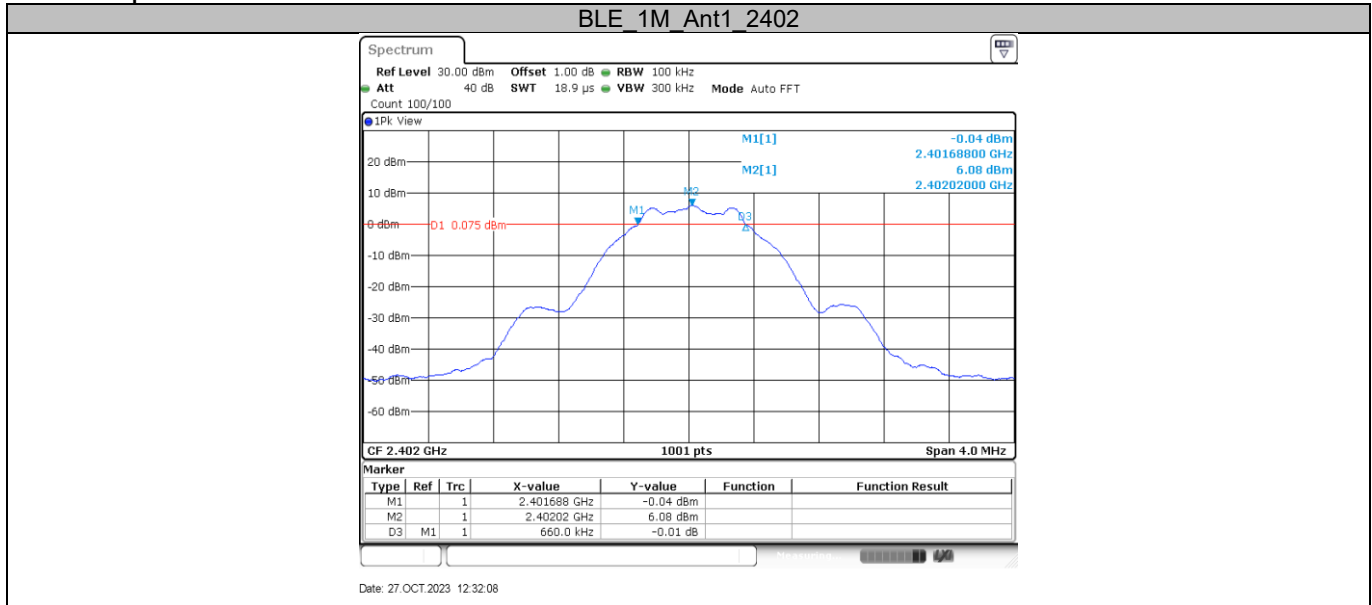

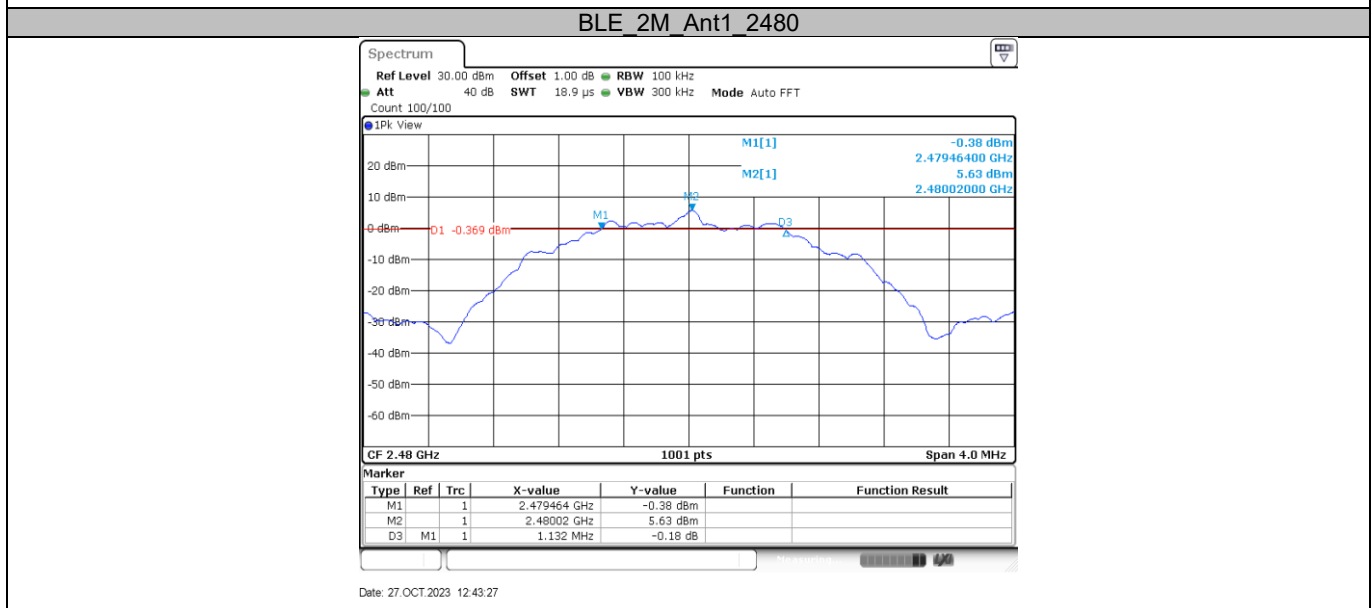
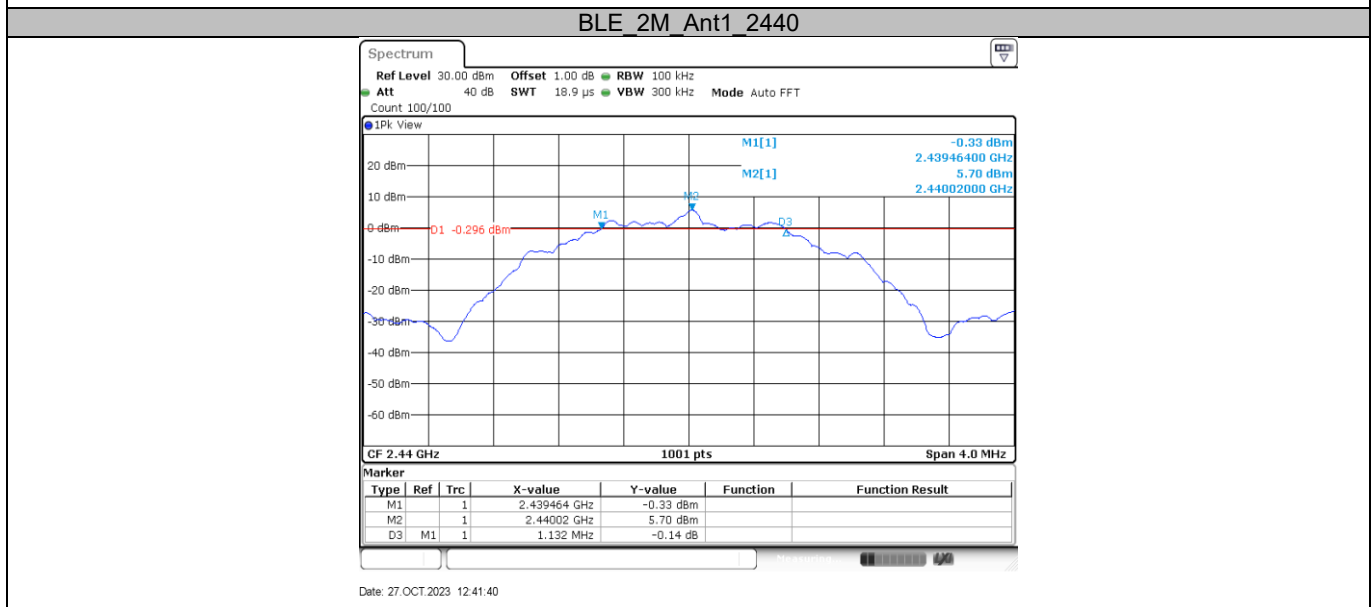
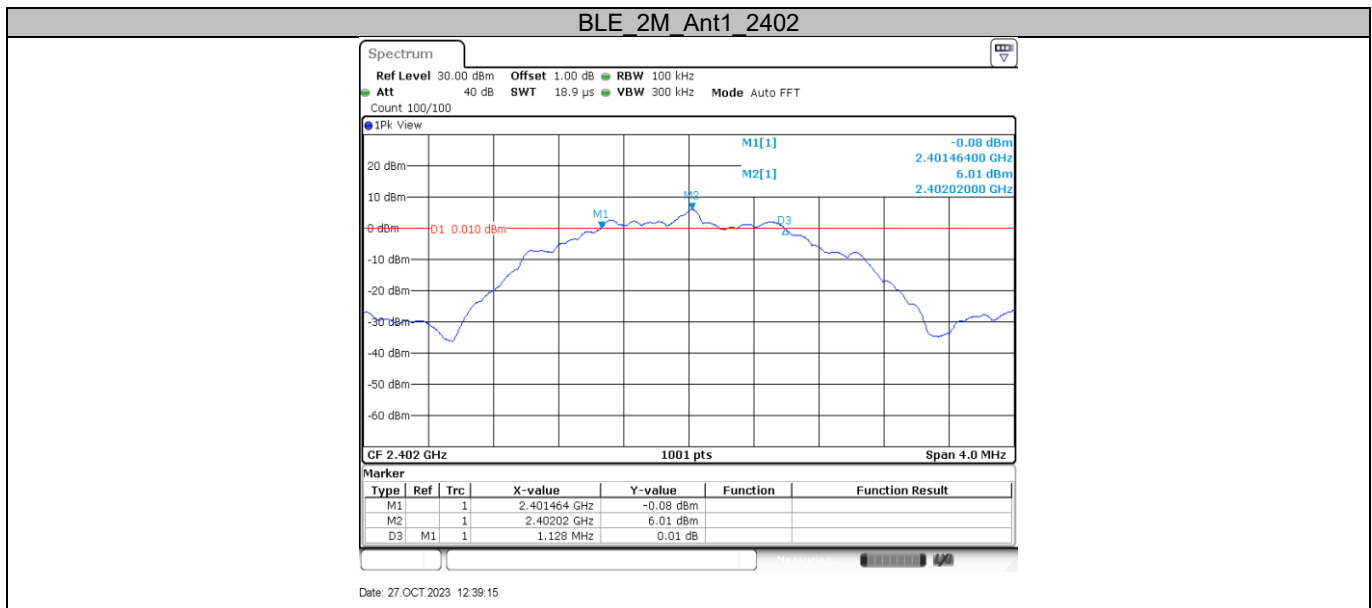

9.5 Spurious RF Conducted Emissions

Test Method

1. The RF output of EUT was connected to the spectrum analyzer by RF cable. The path loss was compensated to the results for each measurement.
2. Set to the maximum power setting, the instrument center frequency is set to the nominal EUT channel center frequency enable the EUT transmit continuously.
3. Use the following spectrum analyzer settings:
Span = wide enough to capture the peak level of the in-band emission and all spurious emissions (e.g., harmonics) from the lowest frequency generated in the EUT up through the 10th harmonic. Typically, several plots are required to cover this entire span.
RBW = 100 kHz, VBW \geq 3RBW, Sweep = auto, Detector function = peak, Trace = max hold
4. Allow the trace to stabilize. Set the marker on the peak of any spurious emission recorded.
5. The level displayed must comply with the limit specified in this Section. Submit these plots.
6. Repeat above procedures until all frequencies measured were complete.

Limit

According to §15.247(d), spurious RF conducted emissions limit as below:

In any 100 kHz bandwidth outside the frequency band in which the spread spectrum or digitally modulated device is operating, the RF power that is produced shall be at least 20 dB below that in the 100 kHz bandwidth within the band that contains the highest level of the desired power, based on either an RF conducted or a radiated measurement, provided that the transmitter demonstrates compliance with the peak conducted power limits.

Frequency Range MHz	Limit (dBc)
30-25000	-20

Spurious RF conducted emissions

Test Mode	Antenna	Channel (MHz)	Frequency Range (MHz)	Reference Level	Result (dBm)	Limit (dBm)	Verdict
BLE_1M	Ant1	2402	Reference	6.10	6.10	---	PASS
			30~1000	30~1000	-63.05	<=-13.9	PASS
			1000~26500	1000~26500	-49.95	<=-13.9	PASS
		2440	Reference	5.74	5.74	---	PASS
			30~1000	30~1000	-62.12	<=-14.26	PASS
			1000~26500	1000~26500	-48.36	<=-14.26	PASS
		2480	Reference	5.67	5.67	---	PASS
			30~1000	30~1000	-61.87	<=-14.33	PASS
			1000~26500	1000~26500	-51.11	<=-14.33	PASS
BLE_2M	Ant1	2402	Reference	6.04	6.04	---	PASS
			30~1000	30~1000	-62.67	<=-13.96	PASS
			1000~26500	1000~26500	-46.84	<=-13.96	PASS
		2440	Reference	5.66	5.66	---	PASS
			30~1000	30~1000	-63.02	<=-14.34	PASS
			1000~26500	1000~26500	-50.8	<=-14.34	PASS
		2480	Reference	5.67	5.67	---	PASS
			30~1000	30~1000	-62.12	<=-14.33	PASS
			1000~26500	1000~26500	-52.35	<=-14.33	PASS

Remark: The emissions exceed limit is fundamental signal.

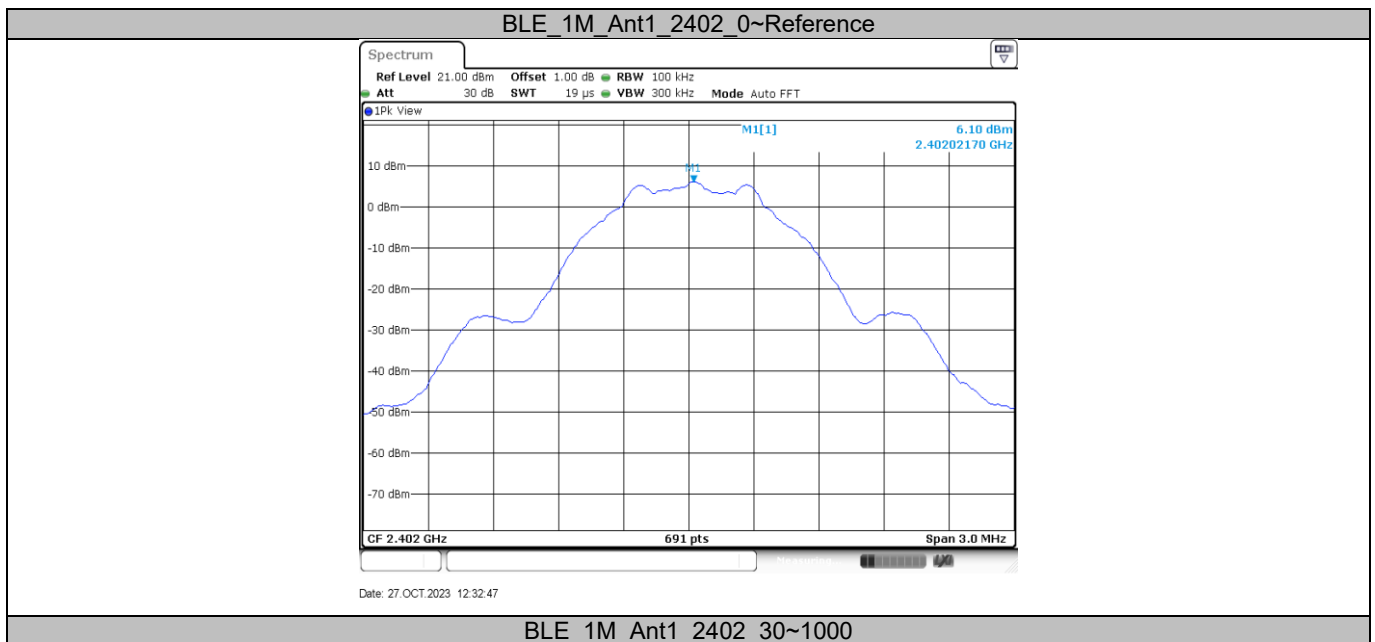

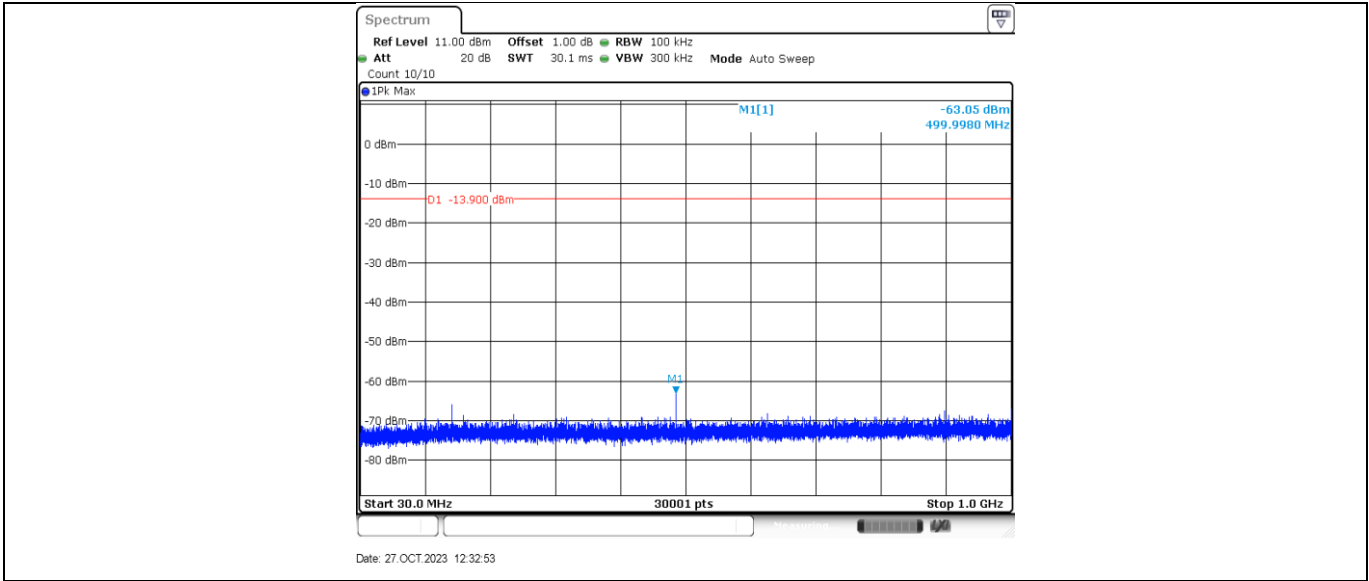

BLE 1M Ant1 2402 1000~26500

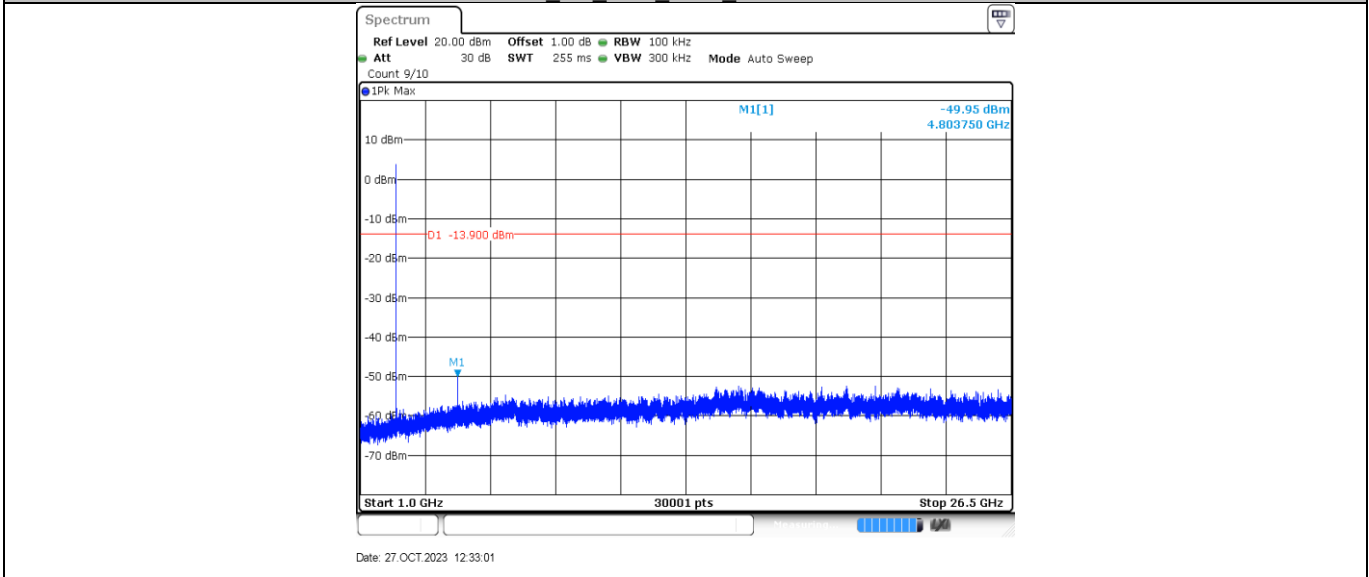

BLE 1M Ant1 2440 0~Reference

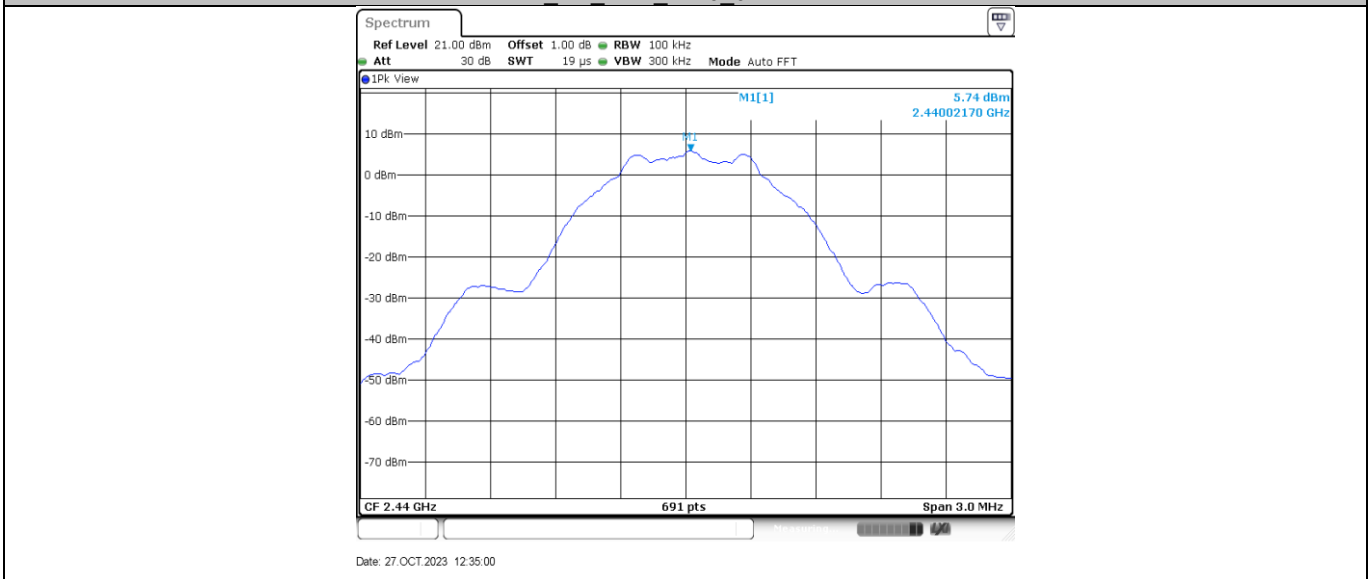

BLE 1M Ant1 2440 30~1000

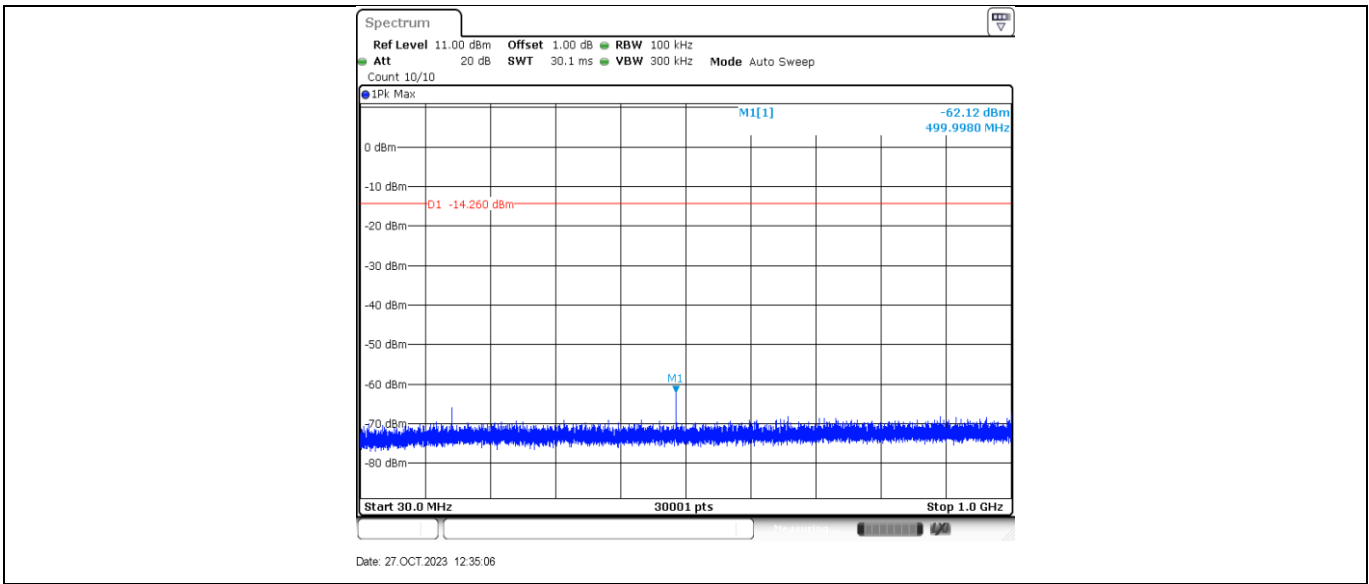

BLE 1M Ant1 2440 1000~26500

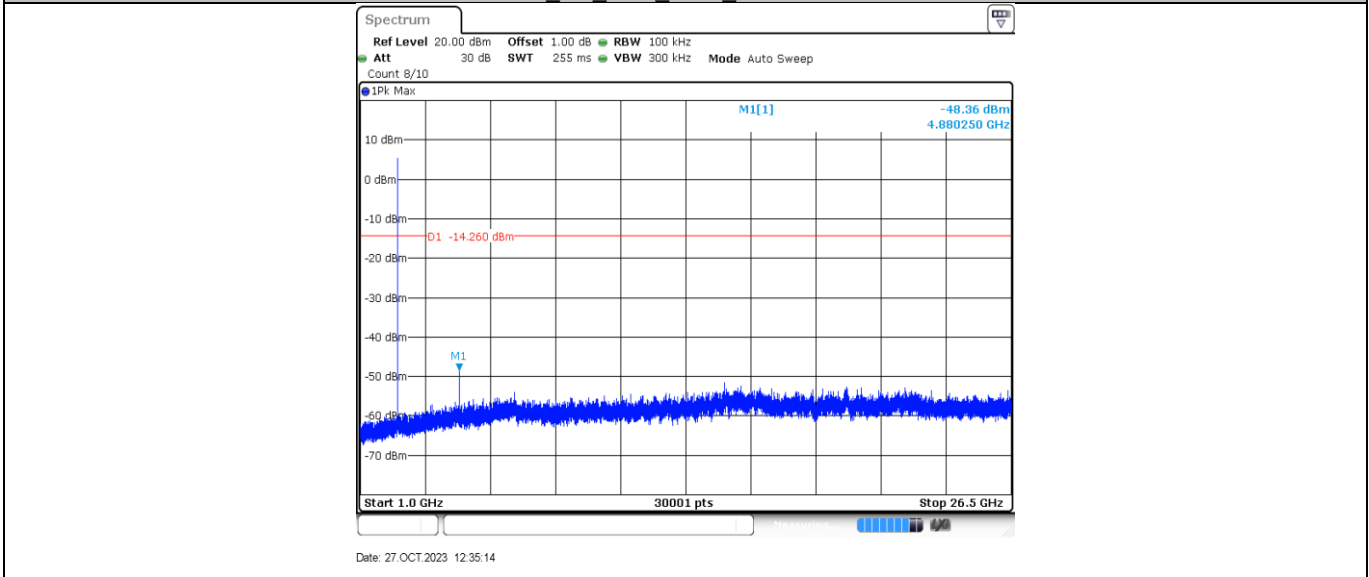

BLE 1M Ant1 2480 0~Reference

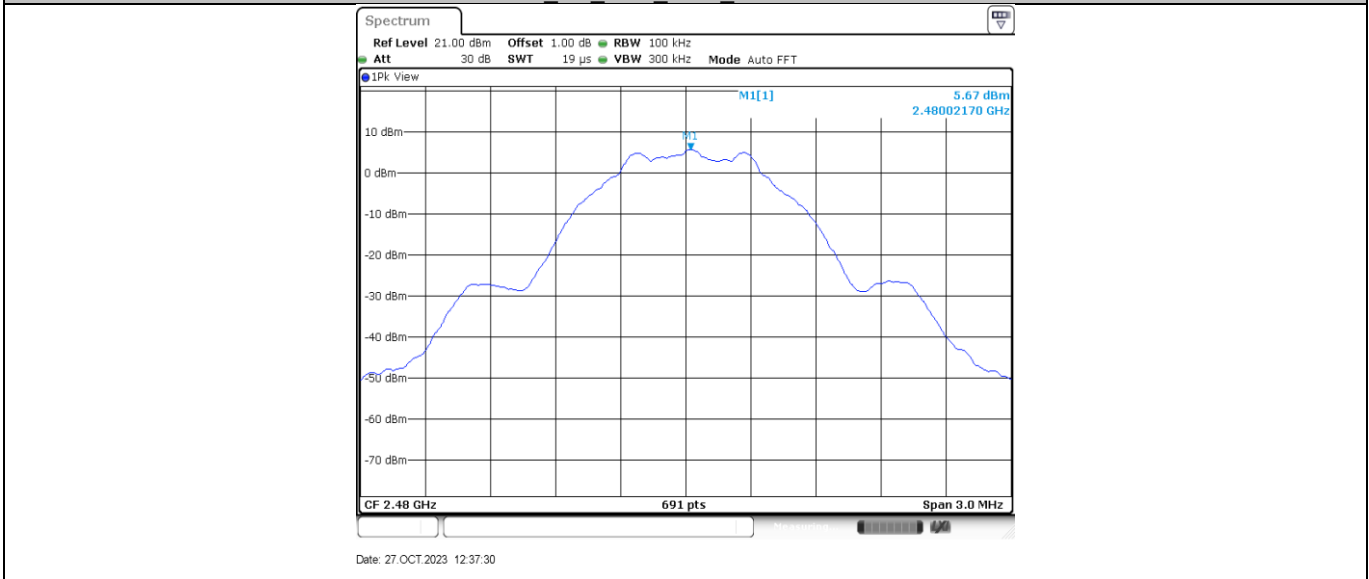

BLE 1M Ant1 2480 30~1000

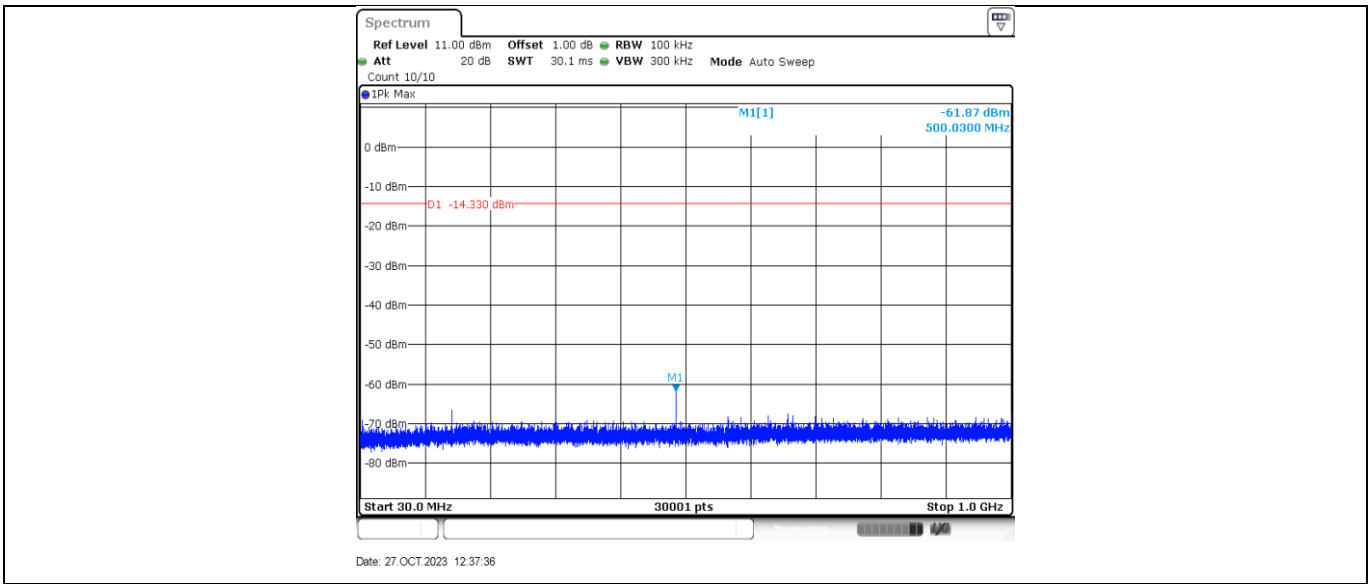

BLE 1M Ant1 2480 1000~26500

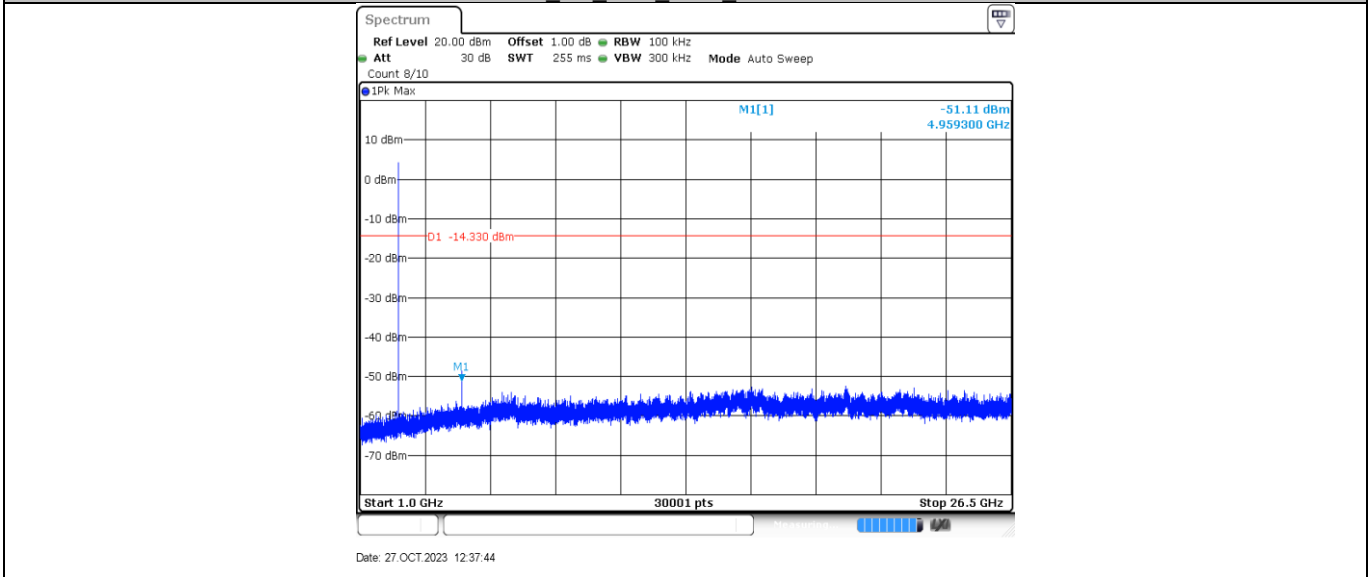

BLE 2M Ant1 2402 0~Reference

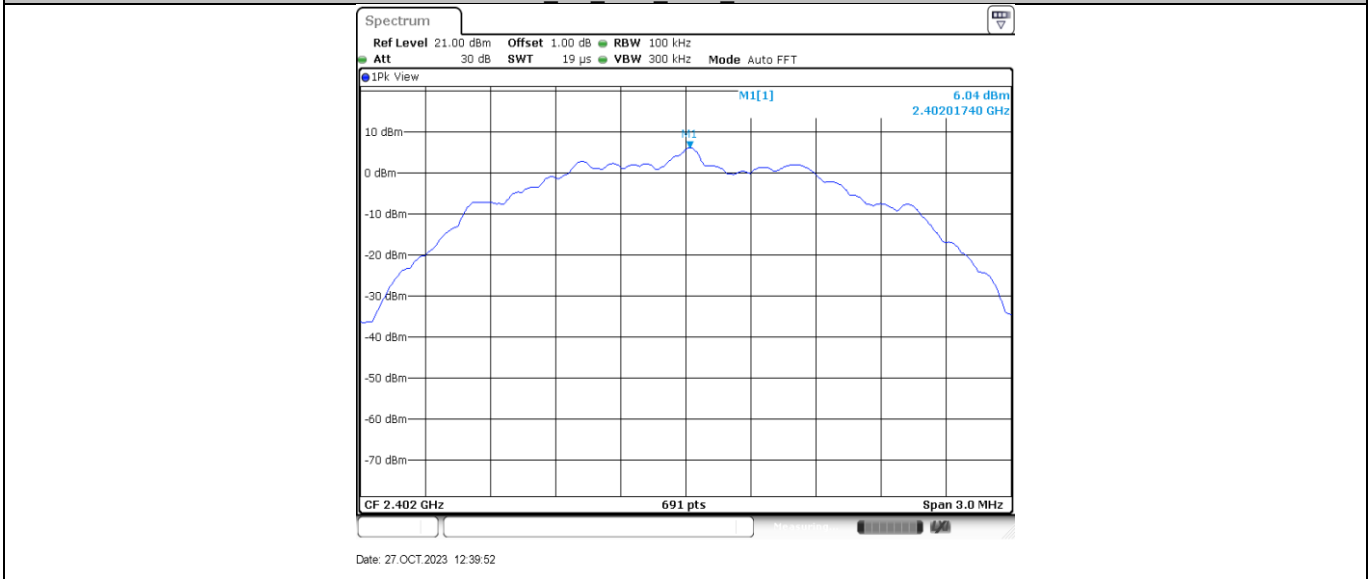

BLE 2M Ant1 2402 30~1000

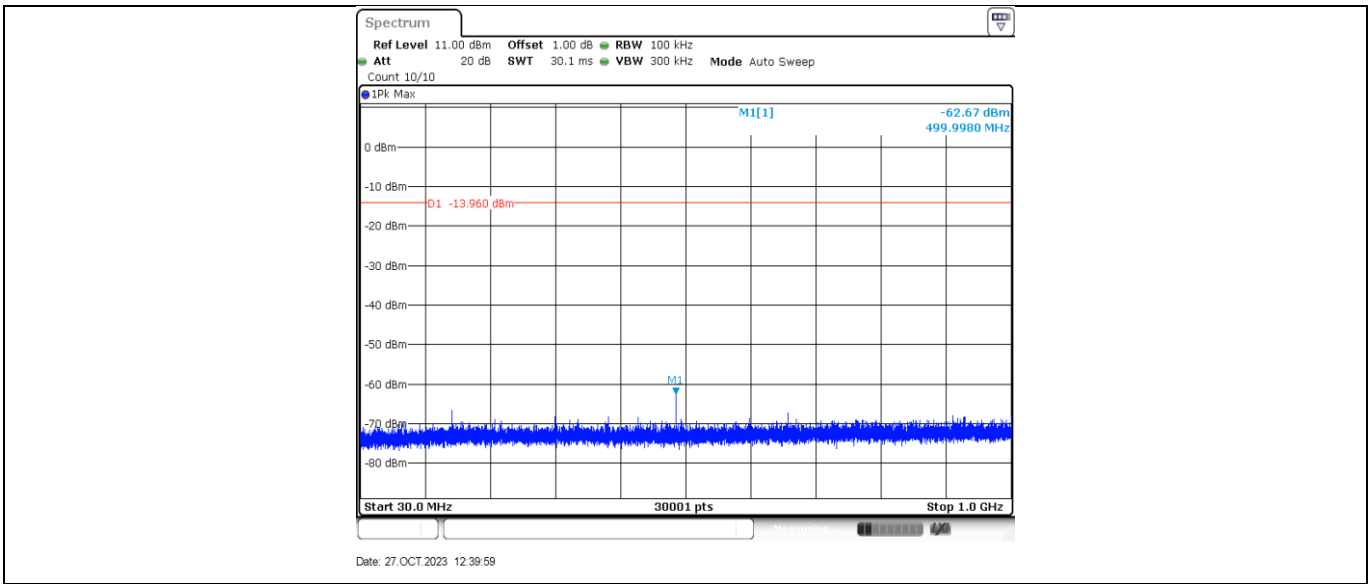

BLE 2M Ant1 2402 1000~26500

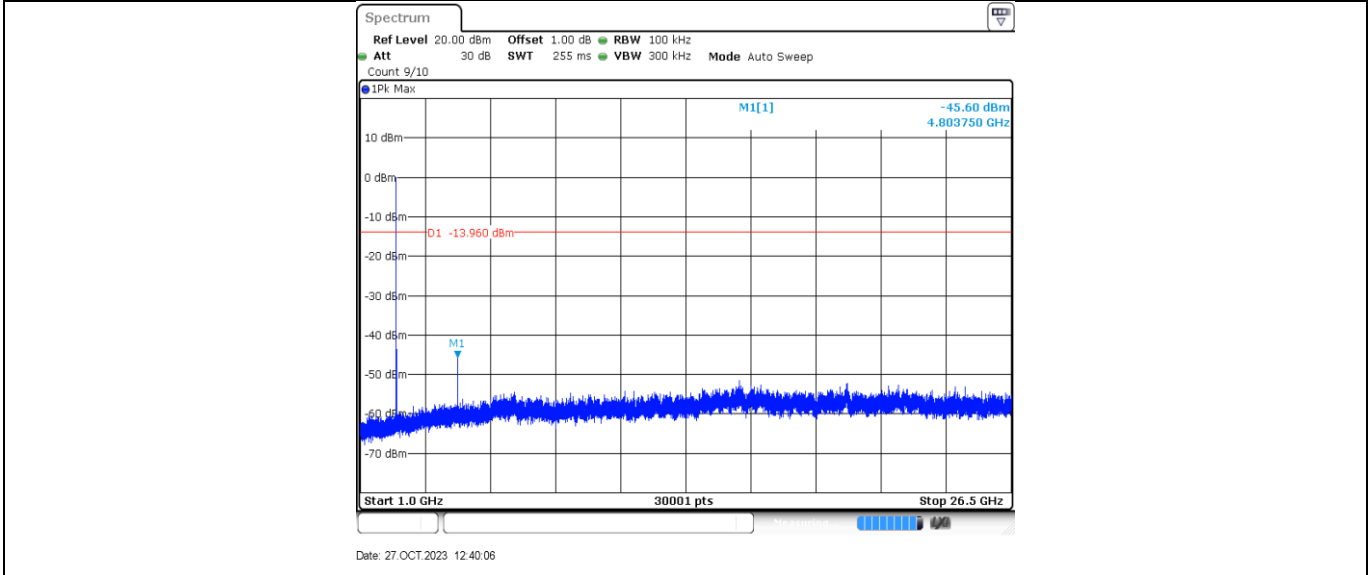

BLE 2M Ant1 2440 0~Reference

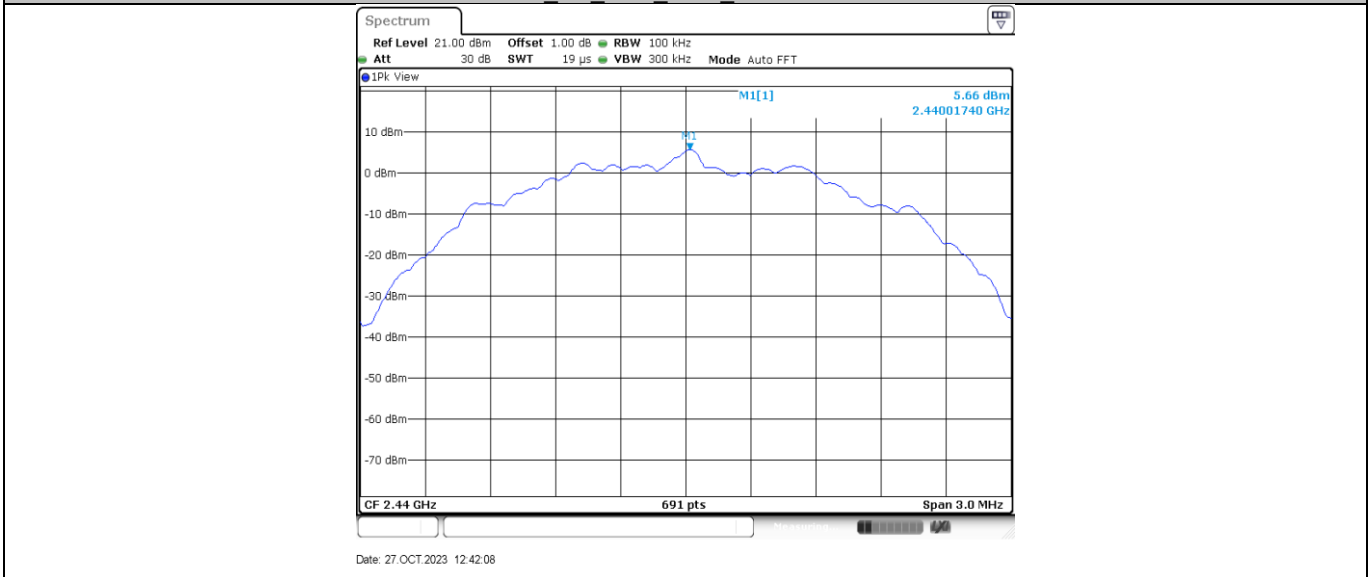

BLE 2M Ant1 2440 30~1000

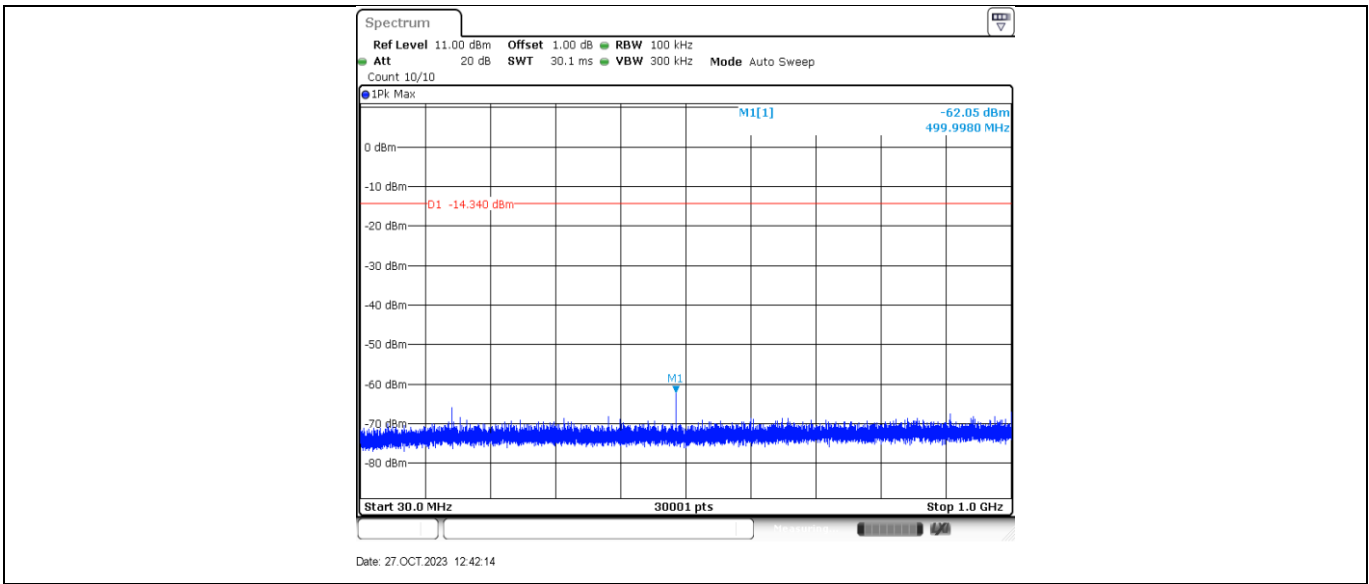

BLE 2M Ant1 2440 1000~26500

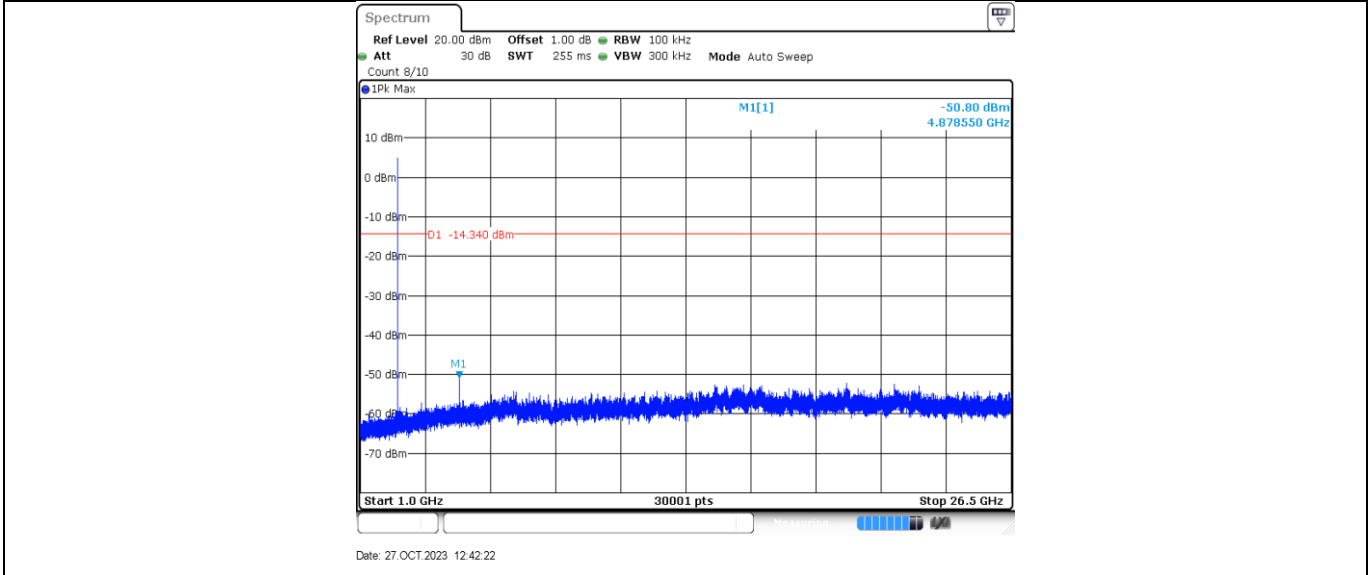

BLE 2M Ant1 2480 0~Reference

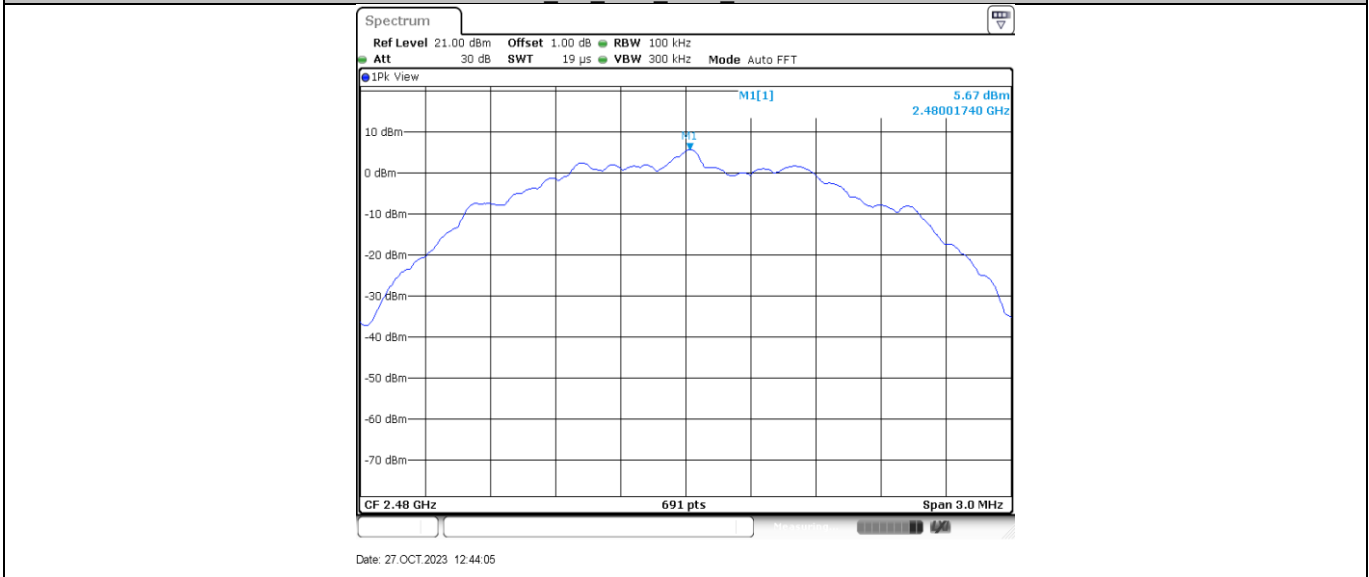

BLE 2M Ant1 2480 30~1000

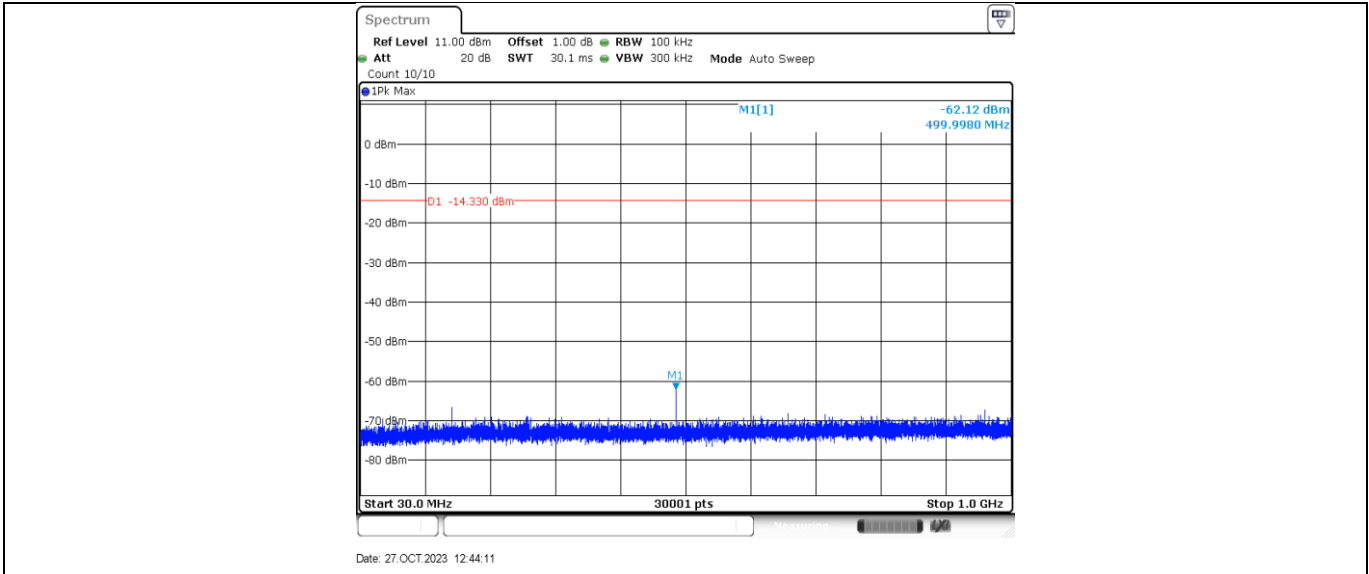

BLE 2M Ant1 2480 1000~26500

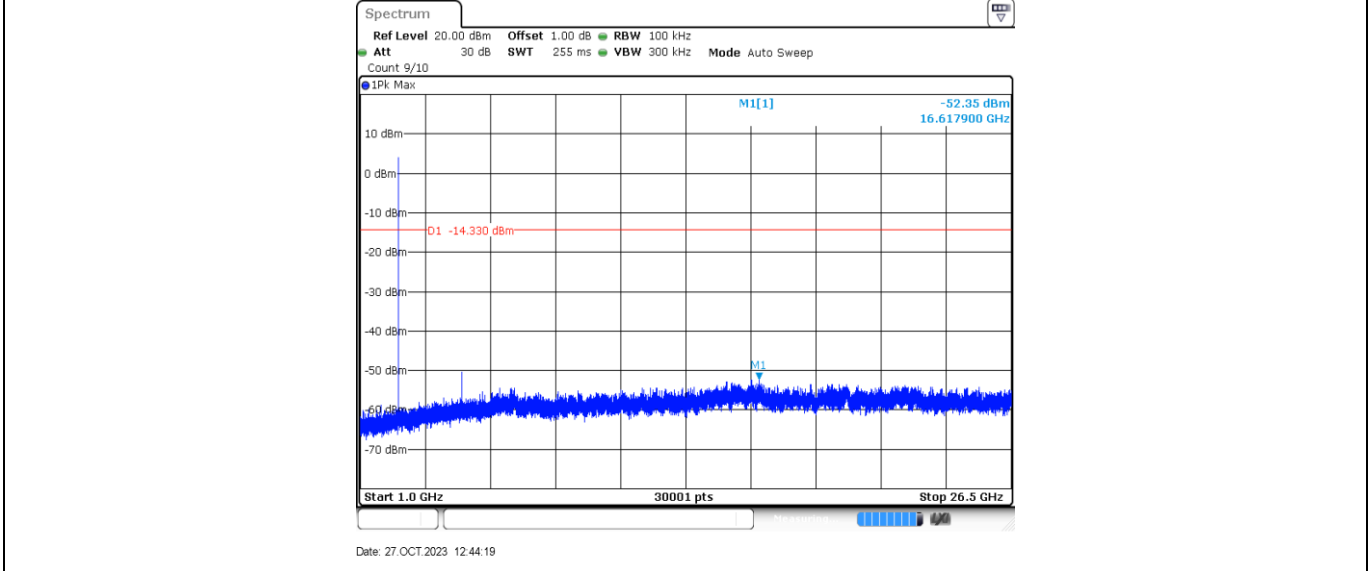

9.6 Band Edge

Test Method

1. The RF output of EUT was connected to the test receiver by RF cable. The path loss was compensated to the results for each measurement.
2. Set to the maximum power setting and enable the EUT transmit continuously. Set the EUT to the lowest frequency channel.
3. Set RBW = 100 kHz, VBW=300 kHz, Peak Detector, Trace: Max hold, Sweep time: Coupled, Span: Wide enough to capture the peak level of the emission operating on the channel closest to the band edge, as well as any modulation products that fall outside of the authorized band of operation. Allow the trace to stabilize.
4. Set the marker on the emission at the band edge, or on the highest modulation product outside of the band, if this level is greater than that at the band edge. Enable the marker-delta function, and then use the marker-to-peak function to move the marker to the peak of the in-band emission.
5. Set the EUT to the highest frequency channel and repeat step 2) to 4)
6. Enable the EUT hopping mode, repeat the test.

Limit:

According to §15.247(d), band edge limit as below:

In any 100kHz bandwidth outside the frequency band in which the spread spectrum or digitally modulated device is operating, the RF power that is produced shall be at least 20 dB below that in the 100 kHz bandwidth within the band that contains the highest level of the desired power, based on either an RF conducted or a radiated measurement, provided that the transmitter demonstrates compliance with the peak conducted power limits.

Frequency Range MHz	Limit (dBc)
30-25000	-20

Band edge testing

Test Mode	Antenna	Channel	Channel (MHz)	Reference Level (dBm)	Result (dBm)	Limit (dBm)	Verdict
BLE_1M	Ant1	Low	2402	6.13	-56.89	<=-13.87	PASS
		High	2480	5.61	-57.19	<=-14.39	PASS
BLE_2M	Ant1	Low	2402	5.85	-29.07	<=-14.15	PASS
		High	2480	5.63	-55.82	<=-14.37	PASS

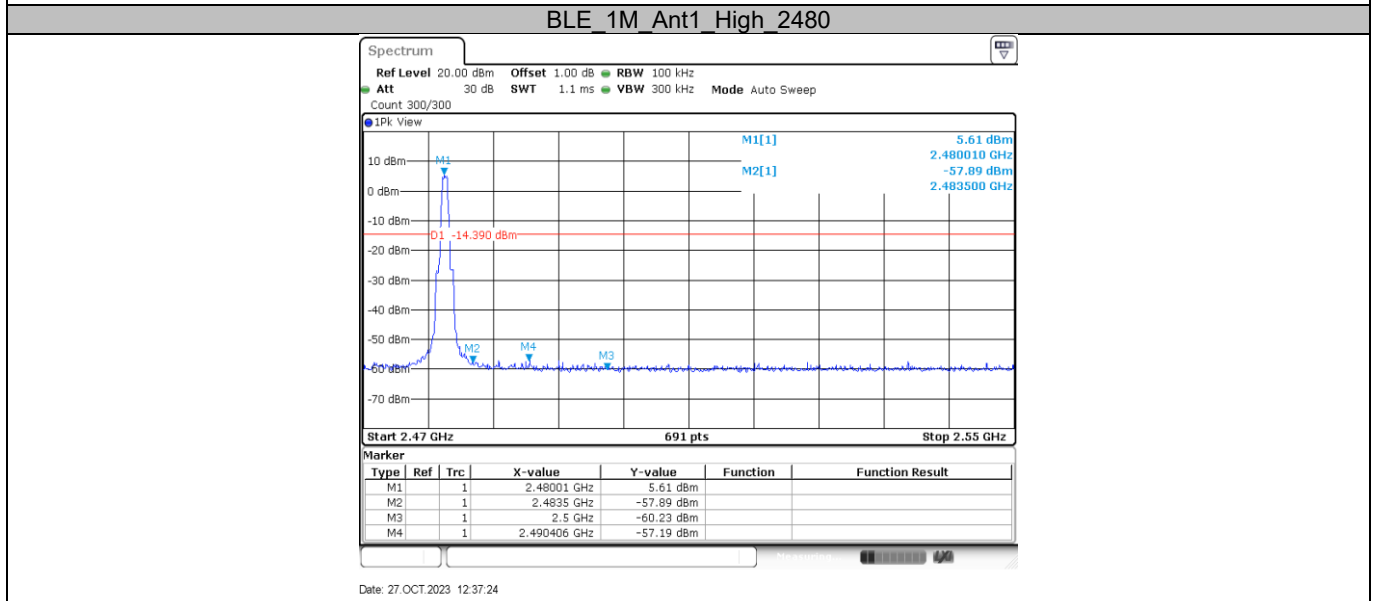
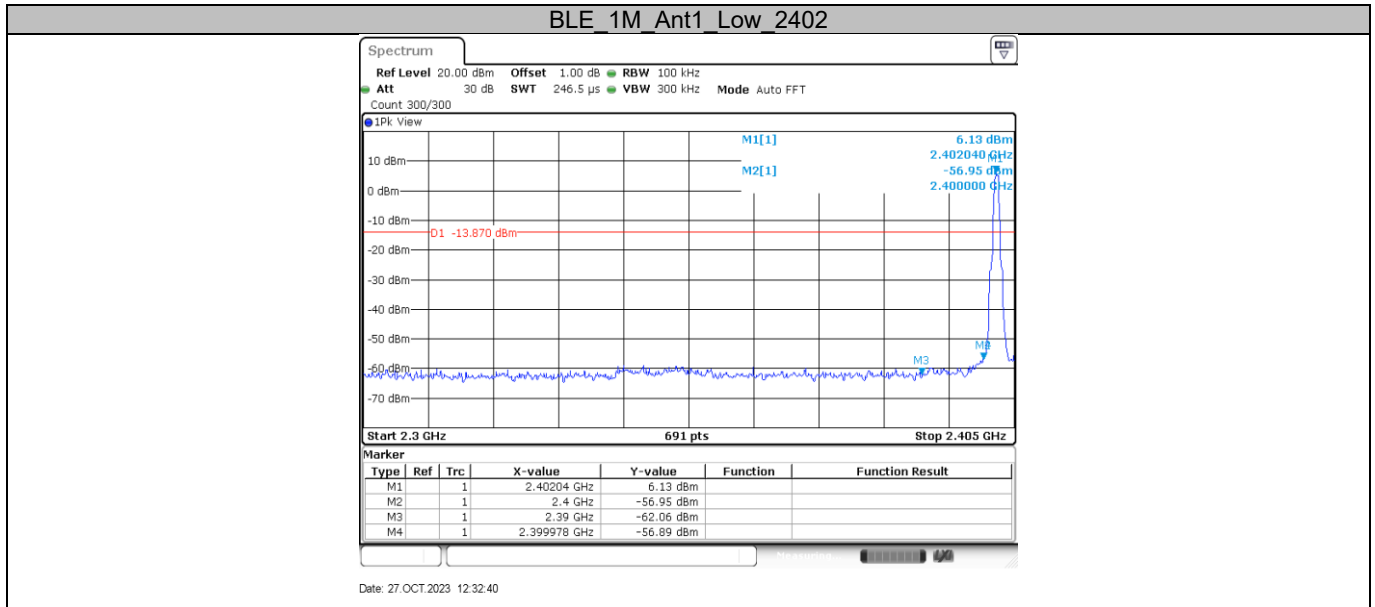

BLE_2M Ant1 Low 2402

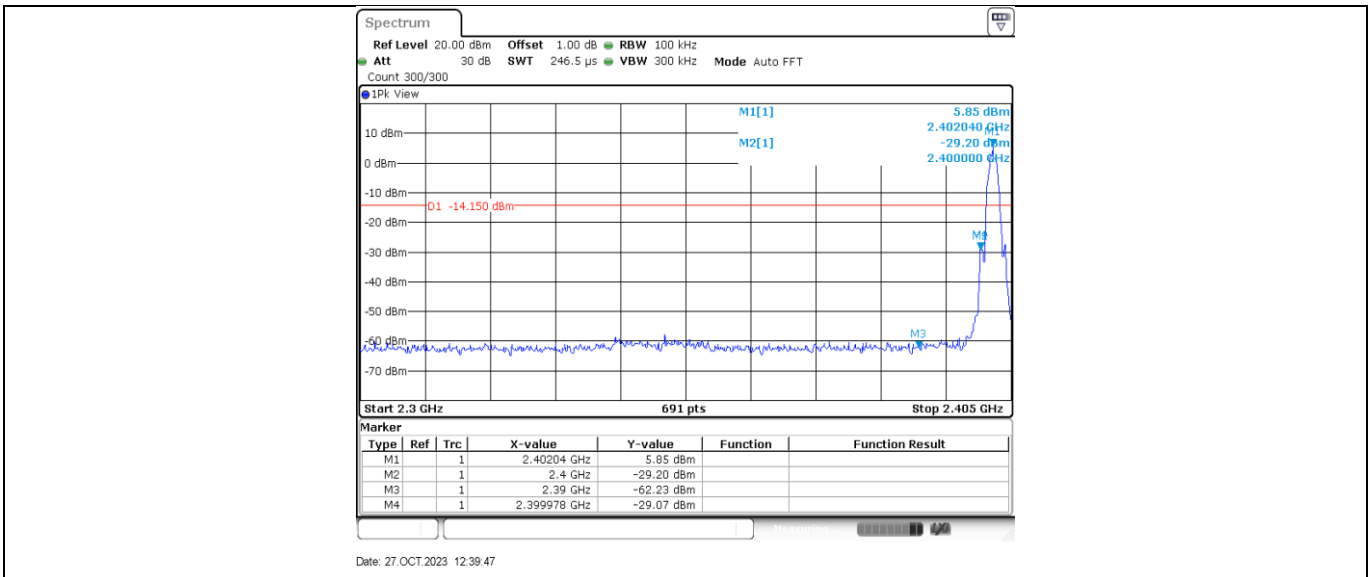

BLE 2M Ant1 High 2480

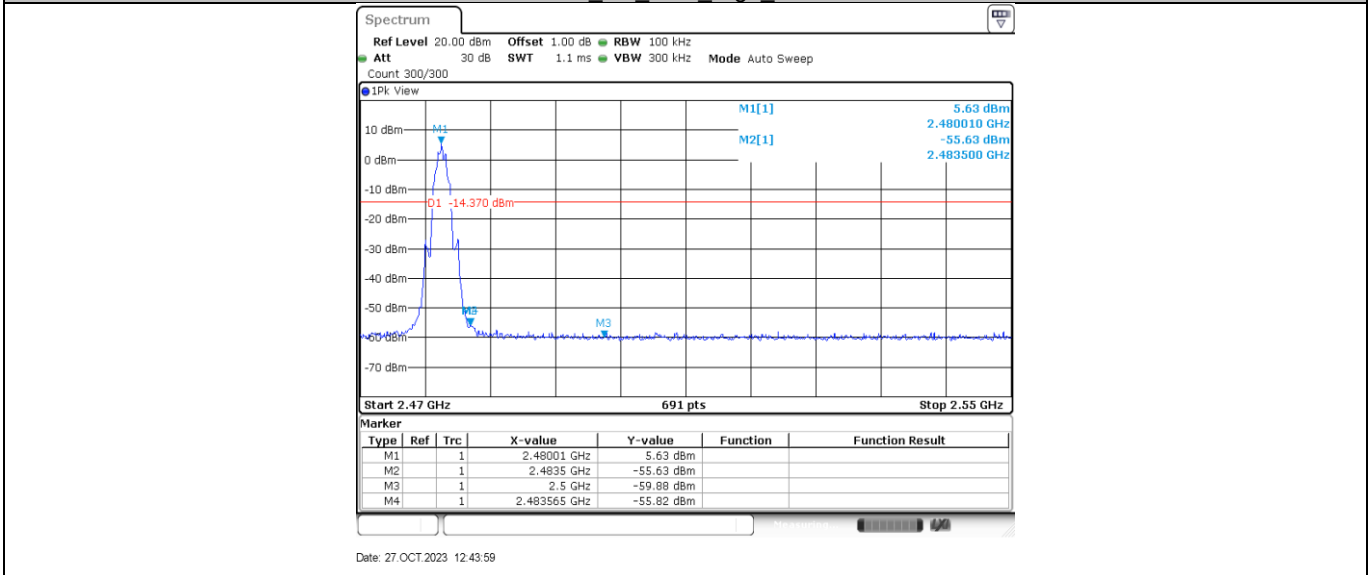

9.7 Spurious Radiated Emissions for Transmitter

Test Method

1. The EUT was placed on a turn table which is 1.5m above ground plane for above 1GHz and 0.8m above ground for below 1GHz at 3 meters chamber room for test. The table was rotated 360 degrees to determine the position of the highest radiation.
2. Set to the maximum power setting and enable the EUT transmit continuously
3. The EUT was set 3 meters away from the interference – receiving antenna, which was mounted on the top of a variable – height antenna tower.
4. The height of antenna is varied from one meter to four meters above the ground to determine the maximum value of the field strength. Both horizontal and vertical polarizations of the antenna are set to make the measurement.
5. For each suspected emission, the EUT was arranged to its worst case and then the antenna was tuned to heights from 1 meter to 4 meters and the rotatable table was turned from 0 degrees to 360 degrees to find the maximum reading.
6. Use the following test receiver settings According to C63.10:
 - (1) Span shall wide enough to fully capture the emission being measured;
 - (2) Set RBW=100 kHz to 120KHz for $f < 1$ GHz; $VBW \geq RBW$; Sweep = auto; Detector function = QP; Trace = max hold;
 - (3) Set RBW = 1 MHz, VBW= 3MHz for $f \geq 1$ GHz for peak measurement.

For average measurement:

The resolution bandwidth of test receiver/spectrum analyzer is 1MHz and the video bandwidth is 3MHz for RMS Average ((duty cycle < 98%) for Average detection (AV) at frequency above 1GHz, then the measurement results was added to a correction factor ($20\log(1/\text{duty cycle})$).

The resolution bandwidth of test receiver/spectrum analyzer is 1MHz and the video bandwidth is 10Hz (duty cycle > 98%) for Average detection (AV) at frequency above 1GHz.

7. Repeat above procedures until all frequencies measured were complete.

Spurious Radiated Emissions for Transmitter

Limit

The radio emission outside the operating frequency band shall be at least 20 dB below that in the 100 kHz bandwidth within the band that contains the highest level of the desired power. Radiated emissions which fall in the restricted bands, as defined in section 15.205, must comply with the radiated emission limits specified in section 15.209.

Frequency MHz	Field Strength $\mu\text{V/m}$	Field Strength $\text{dB}\mu\text{V/m}$	Detector	Measurement distance meters
0.009-0.490	2400/F(kHz)	48.5-13.8	AV	300
0.490-1.705	24000/F(kHz)	33.8-23.0	QP	30
1.705-30	30	29.5	QP	30
30-88	100	40	QP	3
88-216	150	43.5	QP	3
216-960	200	46	QP	3
960-1000	500	54	QP	3
Above 1000	500	54	AV	3
Above 1000	5000	74	PK	3

Note 1: Limit 3m($\text{dB}\mu\text{V/m}$)=Limit 300m($\text{dB}\mu\text{V/m}$)+40Log(300m/3m) (Below 30MHz)

Note 2: Limit 3m($\text{dB}\mu\text{V/m}$)=Limit 30m($\text{dB}\mu\text{V/m}$)+40Log(30m/3m) (Below 30MHz)

Spurious radiated emissions for transmitter

According to C63.10, if the peak (or quasi-peak) measured value complies with the average limit, it is unnecessary to perform an average measurement, so AV emission value did not show in below table if the peak value complies with average limit.

Transmitting spurious emission test result as below:

Test data_30MHz to 1000MHz

Frequency Band	Frequency	Emission Level	Polarization	Limit	Detector	Margin	Correct factor	Result
	MHz	dB μ V/m		dB μ V/m		dB μ V/m	(dB/m)	
30-1000MHz	195.809375	23.84	H	43.50	QP	19.66	19.05	Pass
	389.021250	28.64	H	46.00	QP	17.36	23.84	Pass
	585.385625	35.29	H	46.00	QP	10.71	27.51	Pass
	947.316875	38.92	H	46.00	QP	7.08	32.34	Pass
	Other Frequencies	--	H	--	QP	--	--	Pass
	101.961875	23.65	V	43.50	QP	19.85	18.70	Pass
	197.991875	25.60	V	43.50	QP	17.90	19.10	Pass
	590.660000	33.48	V	46.00	QP	12.52	27.73	Pass
	946.650000	39.46	V	46.00	QP	6.54	32.32	Pass
	Other Frequencies	--	V	--	QP	--	--	Pass

BLE_1M of low channel 2402MHz

Frequency Band	Frequency	Emission Level	Polarization	Limit	Detector	Margin	Correct factor	Result
	MHz	dB μ V/m		dB μ V/m		dB μ V/m	(dB/m)	
1000-25000MHz	1854.000000	47.34	H	74.00	PK	26.66	-7.31	Pass
	2376.000000*	45.23	H	74.00	PK	28.77	-4.77	Pass
	3190.000000	50.99	H	74.00	PK	23.01	-0.21	Pass
	Other Frequencies	--	H	--	PK	--	--	Pass
	3423.000000	46.10	V	74.00	PK	27.90	0.18	Pass
	4812.000000*	49.11	V	74.00	PK	24.89	5.13	Pass
	7417.500000*	46.25	V	74.00	PK	27.75	8.02	Pass
	Other Frequencies	--	V	--	PK	--	--	Pass

BLE_1M of Middle channel 2440MHz

Frequency Band	Frequency	Emission Level	Polarization	Limit	Detector	Margin	Correct factor	Result
	MHz	dB μ V/m		dB μ V/m		dB μ V/m	(dB/m)	
1000-25000MHz	1854.500000	47.65	H	74.00	PK	26.35	-7.31	Pass
	2131.000000	49.30	H	74.00	PK	24.70	-5.48	Pass
	2374.000000*	45.51	H	74.00	PK	28.49	-4.77	Pass
	Other Frequencies	--	H	--	PK	--	--	Pass
	2123.500000	48.60	V	74.00	PK	25.40	-5.50	Pass
	3193.000000	48.99	V	74.00	PK	25.01	-0.21	Pass
	4767.500000*	50.20	V	74.00	PK	23.80	4.85	Pass
Other Frequencies	--	V	--	PK	--	--	Pass	

BLE_1M of high channel 2480MHz

Frequency Band	Frequency	Emission Level	Polarization	Limit	Detector	Margin	Correct factor	Result
	MHz	dB μ V/m		dB μ V/m		dB μ V/m	(dB/m)	
1000-25000MHz	3196.000000	50.96	H	74.00	PK	23.04	-0.22	Pass
	5972.000000	50.99	H	74.00	PK	23.01	8.22	Pass
	7970.000000	40.64	H	74.00	PK	33.36	9.12	Pass
	Other Frequencies	--	H	--	PK	--	--	Pass
	3194.000000	50.93	V	74.00	PK	23.07	-0.21	Pass
	5455.500000*	50.65	V	74.00	PK	23.35	7.09	Pass
	7418.000000*	44.78	V	74.00	PK	29.22	8.02	Pass
	Other Frequencies	--	V	--	PK	--	--	Pass

BLE_2M of low channel 2402MHz

Frequency Band	Frequency	Emission Level	Polarization	Limit	Detector	Margin	Correct factor	Result
	MHz	dB μ V/m		dB μ V/m		dB μ V/m	(dB/m)	
1000-25000MHz	3195.000000	45.63	H	74.00	PK	28.37	-1.05	Pass
	3756.500000*	46.62	H	74.00	PK	27.38	1.07	Pass
	10520.000000	41.38	H	74.00	PK	32.62	9.95	Pass
	Other Frequencies	--	H	--	PK	--	--	Pass
	3197.000000	45.70	V	74.00	PK	28.30	-1.04	Pass
	4242.500000*	48.17	V	74.00	PK	25.83	2.59	Pass
	7936.000000	40.31	V	74.00	PK	33.69	7.66	Pass
	Other Frequencies	--	V	--	PK	--	--	Pass

BLE_2M of Middle channel 2440MHz

Frequency Band	Frequency	Emission Level	Polarization	Limit	Detector	Margin	Correct factor	Result
	MHz	dBµV/m		dBµV/m		dBµV/m	(dB/m)	
1000-25000MHz	3328.000000	45.28	H	74.00	PK	28.72	-0.53	Pass
	4345.000000*	48.30	H	74.00	PK	25.70	3.19	Pass
	7318.500000*	40.40	H	74.00	PK	33.60	6.86	Pass
	Other Frequencies	--	H	--	PK	--	--	Pass
	2171.000000	42.08	V	74.00	PK	31.92	-6.51	Pass
	3193.000000	50.32	V	74.00	PK	23.68	-1.07	Pass
	7978.000000	40.62	V	74.00	PK	33.38	7.80	Pass
	Other Frequencies	--	V	--	PK	--	--	Pass

BLE_2M of high channel 2480MHz

Frequency Band	Frequency	Emission Level	Polarization	Limit	Detector	Margin	Correct factor	Result
	MHz	dBµV/m		dBµV/m		dBµV/m	(dB/m)	
1000-25000MHz	3186.500000	46.80	H	74.00	PK	27.20	-1.10	Pass
	4269.500000*	48.40	H	74.00	PK	25.60	2.77	Pass
	8181.500000*	40.45	H	74.00	PK	33.55	8.12	Pass
	Other Frequencies	--	H	--	PK	--	--	Pass
	3821.000000*	47.33	V	74.00	PK	26.67	1.30	Pass
	6373.500000	46.72	V	74.00	PK	27.28	5.48	Pass
	10405.500000	40.67	V	74.00	PK	33.33	10.04	Pass
	Other Frequencies	--	V	--	PK	--	--	Pass

Remark:

- (1) "*" means the emission(s) appear within the restrict bands shall follow the requirement of section 15.205.
- (2) Data of measurement within frequency ranges 9kHz-30MHz are the noise floor or attenuated more than 20dB below the permissible limits or the field strength is too small to be measured, so test data does not present in this report.
- (3) Level= Reading Level + Correction Factor
- (4) Above 1GHz: Corrector factor = Antenna Factor + Cable Loss- Amplifier Gain
 Below 1GHz: Corrector factor = Antenna Factor + Cable Loss
 (The Reading Level is recorded by software which is not shown in the sheet)

10 Test Equipment List

List of Test Instruments

Conducted Emission 2# Test

DESCRIPTION	MANUFACTURER	MODEL NO.	EQUIPMENT ID	SERIAL NO.	CAL INTERVAL (YEAR)	CAL. DUE DATE
EMI Test Receiver	Rohde & Schwarz	ESR 3	68-4-74-19-002	102590	1	2024-5-19
LISN	Rohde & Schwarz	ENV216	68-4-87-19-001	102472	1	2024-5-20
Attenuator	Shanghai Huaxiang	TS2-26-3	68-4-81-16-003	080928189	1	2024-5-19
Test software	Rohde & Schwarz	EMC32	68-4-90-19-005-A01	Version10.35.02	N/A	N/A
Shielding Room	TDK	CSR #2	68-4-90-19-005	----	3	2025-10-15

Radiated Emission Test 1# Test

DESCRIPTION	MANUFACTURER	MODEL NO.	EQUIPMENT ID	SERIAL NO.	CAL INTERVAL (YEAR)	CAL. DUE DATE
EMI Test Receiver	Rohde & Schwarz	ESR 7	68-4-74-19-001	102176	1	2024-5-20
Loop Antenna	Rohde & Schwarz	HFH2-Z2	68-4-80-14-006	100398	1	2024-8-17
3m Semi-anechoic chamber	TDK	SAC-3 #1	68-4-90-14-001	----	3	2024-5-28
Test software	Rohde & Schwarz	EMC32	68-4-90-14-001-A10	Version10.35.02	N/A	N/A

Radiated Emission 2# Test

DESCRIPTION	MANUFACTURER	MODEL NO.	EQUIPMENT ID	SERIAL NO.	CAL INTERVAL (YEAR)	CAL. DUE DATE
EMI Test Receiver	Rohde & Schwarz	ESR 26	68-4-74-14-002	101269	1	2024-5-20
Trilog Super Broadband Test Antenna	Schwarzbeck	VULB 9162	68-4-80-19-003	284	1	2024-3-5
Wave Guide Antenna	ETS	3117	68-4-80-19-001	00218954	1	2024-4-26
Pre-amplifier	Rohde & Schwarz	SCU 18F	68-4-29-19-001	100745	1	2024-5-19
Pre-amplifier	Rohde & Schwarz	SCU 18F	68-4-29-19-002	100746	1	2024-5-19
Sideband Horn Antenna	Q-PAR	QWH-SL-18-40-K-SG	68-4-80-14-008	12827	1	2024-7-11
Pre-amplifier	Rohde & Schwarz	SCU 40A	68-4-29-14-002	100432	1	2024-8-1
Attenuator	Mini-circuits	UNAT-6+	68-4-81-21-002	15542	1	2024-5-19
3m Semi-anechoic chamber	TDK	SAC-3 #2	68-4-90-19-006	----	2	2024-5-28
Test software	Rohde & Schwarz	EMC32	68-4-90-19-006-A01	Version10.35.02	N/A	N/A

RF conducted test

DESCRIPTION	MANUFACTURER	MODEL NO.	EQUIPMENT ID	SERIAL NO.	CAL INTERVAL (YEAR)	CAL. DUE DATE
Signal Analyzer	Rohde & Schwarz	FSV40	68-4-74-14-004	101030	1	2024-5-19
RF Switch Module	Rohde & Schwarz	OSP120/OSP-B157W	68-4-93-14-003	101226/100929	1	2024-5-20
Test software	Tonscend	System for BT/WIFI	68-4-74-14-006-A13	Version 2.6.77.0518	N/A	N/A
Shielding Room	TDK	TS8997	68-4-90-19-003	----	3	2025-10-15

11 System Measurement Uncertainty

For a 95% confidence level, the measurement expanded uncertainties for defined systems, in accordance with the recommendations of ISO 17025 were:

System Measurement Uncertainty	
Test Items	Extended Uncertainty
Uncertainty for Conducted Emission in new shielding room (68-4-90-19-005) 150kHz-30MHz (for test using AMN ENV216)	3.15dB
Uncertainty for Radiated Emission in 3m chamber (68-4-90-14-001) 9kHz-30MHz	4.70dB
Uncertainty for Radiated Emission in 3m chamber (68-4-90-14-001) 30MHz-1000MHz	Horizontal: 4.63dB; Vertical: 4.78dB;
Uncertainty for Radiated Emission in new 3m chamber (68-4-90-19-006) 1000MHz-18000MHz	Horizontal: 5.38dB; Vertical: 5.38dB;
Uncertainty for Radiated Emission in new 3m chamber (68-4-90-19-006) 18GHz-40GHz	Horizontal: 5.29dB; Vertical: 5.29dB;
Uncertainty for Conducted RF test with TS 8997	RF Power Conducted: 1.31dB Frequency test involved: 0.6×10^{-8} or 1%

Measurement Uncertainty Decision Rule:

Determination of conformity with the specification limits is based on the decision rule according to IEC Guide 115: 2021, clause 4.4.3 and 4.5.1.

THE END