



CTC Laboratories, Inc.

2/F., Building 1 and 1-2/F., Building 2, Jiaquan Building, Guanlan High-Tech Park, Longhua District, Shenzhen, Guangdong, China

Tel: +86-755-27521059 Fax: +86-755-27521011 Http://www.sz-ctc.org.cn

TEST REPORT

Report No. : **CTC20231341E02**

FCC ID..... : **WNA-HP46H**

Applicant : **Shenzhen Skyworth Digital Technology Co.,LTD**

Address..... : 14/F,Block A,Skyworth Building,Gaoxin Ave.1.S.,Nanshan District,Shenzhen,China

Manufacturer..... : Shenzhen Skyworth Digital Technology Co.,LTD

Address..... : 14/F,Block A,Skyworth Building,Gaoxin Ave.1.S.,Nanshan District,Shenzhen,China

Product Name : **4K UHD Streaming TV Box**

Trade Mark : SKYWORTH, STRONG, QVWI, MECOOL, XG500, Next, NEXT, 9MAX, coocaa, COOCOA, TESLA, SVI studio, QQBOX

Model/Type reference..... : HP46H

Listed Model(s) : Leap-S3, LEAP-S3, Leap S3, MECOOL, THOMSON, KM7 PLUS, THA 200, THA200, XG500, Start-4K, 9MAX, ATBOX001 THE ULTRA, atbox001 the ultra, QQBOX s100

Standard : **FCC CFR Title 47 Part 15 Subpart C Section 15.247**

Date of receipt of test sample..... : Jul. 01, 2023

Date of testing..... : Jul. 01, 2023 ~ Jul. 12, 2023

Date of issue..... : Aug. 03, 2023

Result..... : **PASS**

Compiled by:

(Printed name+signature)

Lucy Lan

Supervised by:

(Printed name+signature)

Eric Zhang

Approved by:

(Printed name+signature)

Totti Zhao

Testing Laboratory Name : **CTC Laboratories, Inc.**

Address..... : 2/F., Building 1 and 1-2/F., Building 2, Jiaquan Building, Guanlan High-Tech Park, Longhua District, Shenzhen, Guangdong, China

This test report may be duplicated completely for legal use with the approval of the applicant. It should not be reproduced except in full, without the written approval of our laboratory. The client should not use it to claim product endorsement by CTC. The Test Result in the report only apply to the tested sample. The test report shall be invalid without all the signatures of testing engineers, reviewer and approver. Any objections must be raised to CTC within 15 days since the date when the report is received. It will not be taken into consideration beyond this limit. The test report merely corresponds to the test sample.



Table of Contents

Page

1. TEST SUMMARY 3

1.1. TEST STANDARDS.....3

1.2. REPORT VERSION3

1.3. TEST DESCRIPTION.....3

1.4. TEST FACILITY4

1.5. MEASUREMENT UNCERTAINTY5

1.6. ENVIRONMENTAL CONDITIONS.....5

2. GENERAL INFORMATION 6

2.1. CLIENT INFORMATION6

2.2. GENERAL DESCRIPTION OF EUT6

2.3. ACCESSORY EQUIPMENT INFORMATION7

2.4. OPERATION STATE8

2.5. MEASUREMENT INSTRUMENTS LIST9

3. TEST ITEM AND RESULTS 11

3.1. CONDUCTED EMISSION.....11

3.2. RADIATED EMISSION.....14

3.3. BAND EDGE EMISSIONS (RADIATED)28

3.4. BAND EDGE AND SPURIOUS EMISSIONS (CONDUCTED).....41

3.5. 20dB BANDWIDTH.....56

3.6. CHANNEL SEPARATION.....63

3.7. NUMBER OF HOPPING CHANNEL.....65

3.8. DWELL TIME67

3.9. PEAK OUTPUT POWER75

3.10. DUTY CYCLE79

3.11. ANTENNA REQUIREMENT.....83



1. TEST SUMMARY

1.1. Test Standards

The tests were performed according to following standards:

[FCC Rules Part 15.247](#): Operation within the bands 902–928MHz, 2400–2483.5MHz, and 5725–5850MHz.

[ANSI C63.10-2013](#): American National Standard of Procedures for Compliance Testing of Unlicensed Wireless Devices.

1.2. Report Version

Revised No.	Date of issue	Description
01	Aug. 03, 2023	Original

1.3. Test Description

FCC Part 15 Subpart C (15.247)			
Test Item	Standard Section	Result	Test Engineer
Antenna Requirement	15.203	Pass	Lucy
Conducted Emission	15.207	Pass	Lucy
Restricted Bands	15.205	Pass	Lucy
Hopping Channel Separation	15.247(a)(1)	Pass	Lucy
Dwell Time	15.247(a)(iii)	Pass	Lucy
Peak Output Power	15.247(b)(1)	Pass	Lucy
Number of Hopping Frequency	15.247(a)(iii)	Pass	Lucy
Conducted Band Edge and Spurious Emissions	15.247(d)	Pass	Lucy
Radiated Band Edge and Spurious Emissions	15.205&15.209&15.247(d)	Pass	Lucy
Radiated Spurious Emission	15.247(d) &15.209	Pass	Lucy
20dB Bandwidth	15.247(a)	Pass	Lucy

Note:

- The measurement uncertainty is not included in the test result.
- N/A: means this test item is not applicable for this device according to the technology characteristic of device.



1.4. Test Facility

Address of the report laboratory

CTC Laboratories, Inc.

Add: 2/F., Building 1 and 1-2/F., Building 2, Jiaquan Building, Guanlan High-Tech Park, Longhua District, Shenzhen, Guangdong, China

Laboratory accreditation

The test facility is recognized, certified, or accredited by the following organizations:

A2LA-Lab Cert. No.: 4340.01

CTC Laboratories, Inc. EMC Laboratory has been accredited by A2LA for technical competence in the field of electrical testing, and proved to be in compliance with ISO/IEC 17025:2017 General Requirements for the Competence of Testing and Calibration Laboratories and any additional program requirements in the identified field of testing.

Industry Canada (Registration No.: 9783A, CAB Identifier: CN0029)

CTC Laboratories, Inc. EMC Laboratory has been registered by Certification and Engineer Bureau of Industry Canada for the performance of with Registration NO.: 9783A on Jan, 2016.

FCC (Registration No.: 951311, Designation Number CN1208)

CTC Laboratories, Inc. EMC Laboratory has been registered and fully described in a report filed with the (FCC) Federal Communications Commission. The acceptance letter from the FCC is maintained in our files. Registration 951311, Aug 26, 2017.



1.5. Measurement Uncertainty

The data and results referenced in this document are true and accurate. The reader is cautioned that there may be errors within the calibration limits of the equipment and facilities. The measurement uncertainty was calculated for all measurements listed in this test report acc. to TR-100028-01 "Electromagnetic compatibility and Radio spectrum Matters (ERM); Uncertainties in the measurement of mobile radio equipment characteristics; Part 1" and TR-100028-02 "Electromagnetic compatibility and Radio spectrum Matters (ERM); Uncertainties in the measurement of mobile radio equipment characteristics; Part 2" and is documented in the CTC Laboratories, Inc. quality system acc. to DIN EN ISO/IEC 17025. Furthermore, component and process variability of devices similar to that tested may result in additional deviation. The manufacturer has the sole responsibility of continued compliance of the device.

Below is the best measurement capability for CTC Laboratories, Inc.

Test Items	Measurement Uncertainty	Notes
20dB Emission Bandwidth	±0.0196%	(1)
Carrier Frequency Separation	±1.9%	(1)
Number of Hopping Channel	±1.9%	(1)
Time of Occupancy	±0.028%	(1)
Max Peak Conducted Output Power	±0.743 dB	(1)
Band-edge Spurious Emission	±1.328 dB	(1)
Conducted RF Spurious Emission	9kHz-1GHz: ±0.746dB 1GHz-26GHz: ±1.328dB	(1)
Conducted Emissions 9kHz~30MHz	±3.08 dB	(1)
Radiated Emissions 30~1000MHz	±4.51 dB	(1)
Radiated Emissions 1~18GHz	±5.84 dB	(1)
Radiated Emissions 18~40GHz	±6.12 dB	(1)

Note (1): This uncertainty represents an expanded uncertainty expressed at approximately the 95% confidence level using a coverage factor of k=2.

1.6. Environmental Conditions

During the measurement the environmental conditions were within the listed ranges:

Temperature:	15 °C to 35 °C
Relative Humidity:	20 % to 75 %
Air Pressure:	101 kPa



2. GENERAL INFORMATION

2.1. Client Information

Applicant:	Shenzhen Skyworth Digital Technology Co.,LTD
Address:	14/F,Block A,Skyworth Building,Gaoxin Ave.1.S.,Nanshan District,Shenzhen,China
Manufacturer:	Shenzhen Skyworth Digital Technology Co.,LTD
Address:	14/F,Block A,Skyworth Building,Gaoxin Ave.1.S.,Nanshan District,Shenzhen,China
Factory:	Shenzhen Skyworth Digital Technology Co.,LTD
Address:	14/F,Block A,Skyworth Building,Gaoxin Ave.1.S.,Nanshan District,Shenzhen,China

2.2. General Description of EUT

Product Name:	4K UHD Streaming TV Box
Trade Mark:	SKYWORTH, STRONG, QVWI, MECOOL, XG500, Next, NEXT, 9MAX, coocaa, COOCOA, TESLA, SVI studio, QQBOX
Model/Type reference:	HP46H
Listed Model(s):	Leap-S3, LEAP-S3, Leap S3, MECOOL, THOMSON, KM7 PLUS, THA 200, THA200, XG500, Start-4K, 9MAX, ATBOX001 THE ULTRA, atbox001 the ultra, QQBOX s100
Model Difference:	All these models are identical in the same PCB, layout and electrical circuit, Different is Trade Mark and model number.
Power Supply:	DC12V 1A from AC/DC Adapter
Adapter Model 1:	YS-SKY120100U00P ^{Note1} Input: 100-240Vac 50/60Hz 0.5A Output:12Vdc 1A
Adapter Model 2:	RJ-SKY120100U00S ^{Note2} Input: 100-240Vac 50/60Hz 0.5A Output:12Vdc 1A
Hardware Version:	/
Software Version:	/
Bluetooth 5.0 / BR+EDR	
Modulation:	GFSK, $\pi/4$ -DQPSK, 8-DPSK
Operation Frequency:	2402MHz~2480MHz
Channel Number:	79
Channel Separation:	1MHz
Antenna Type:	Onboard antenna
Antenna Gain:	1.2dBi

Note:

1. YS-SKY120100U0XP, (where X represents for marketing purpose with no safety impact, it can be 0-9)
2. RJ-SKY120100UXXS (XX=00-99, stands for customer code)

CTC Laboratories, Inc.

2/F., Building 1 and 1-2/F., Building 2, Jiaquan Building, Guanlan High-Tech Park, Longhua District, Shenzhen, Guangdong, China
Tel.: (86)755-27521059 Fax: (86)755-27521011 Http://www.sz-ctc.org.cn



For anti-fake verification, please visit the official website of Certification and Accreditation Administration of the People's Republic of China : <http://yz.cnca.cn>



2.3. Accessory Equipment Information

Equipment Information			
Name	Model	S/N	Manufacturer
Notebook	ThinkBook 14G3 ACL	MP246QDR	Lenovo
Displayer	EW3270-T	EW3270U	BenQ

Cable Information			
Name	Shielded Type	Ferrite Core	Length
LAN Cable	Without	Without	1.5M
HDMI Cable	Without	Without	1.5M

Test Software Information			
Name	Version	/	/
SecureCRT	/	/	/



2.4. Operation State

Operation Frequency List: The EUT has been tested under typical operating condition. The Applicant provides communication tools software to control the EUT for staying in continuous transmitting and receiving mode for testing. BT EDR, 79 channels are provided to the EUT. Channels 00/39/78 were selected for testing.

Operation Frequency List:

Channel	Frequency (MHz)
00	2402
01	2403
:	:
38	2440
39	2441
40	2442
:	:
77	2479
78	2480

Note: The display in grey were the channel selected for testing.

Test Mode	Frequency (MHz)	Test Software Power Settings
GFSK	2402	0x00
	2441	0x00
	2480	0x00
$\pi/4$ -DQPSK	2402	0x00
	2441	0x00
	2480	0x00
8-DPSK	2402	0x00
	2441	0x00
	2480	0x00

Test Mode:

For RF test items:
The engineering test program was provided and enabled to make EUT continuous transmit.
For AC power line conducted emissions:
The EUT was set to connect with the Bluetooth instrument under large package sizes transmission.
For Radiated spurious emissions test item:
The engineering test program was provided and enabled to make EUT continuous transmit. The EUT in each of three orthogonal axis emissions had been tested, but only the worst case (X axis) data recorded in the report.



2.5. Measurement Instruments List

Tonscend RF Test System					
Item	Test Equipment	Manufacturer	Model No.	Serial No.	Calibrated Until
1	MXA Signal Analyzer	Keysight	N9020A	MY46471737	Dec. 16, 2023
2	Spectrum Analyzer	R&S	FSU26	100105	Dec. 16, 2023
3	Spectrum Analyzer	R&S	FSV40-N	101331	Mar. 14, 2024
4	MXG Vector Signal Generator	Agilent	N5182A	MY47420864	Dec. 16, 2023
5	PSG Analog Signal Generator	Agilent	E8257D	MY46521908	Dec. 16, 2023
6	Power Sensor	Keysight	U2021XA	MY55130004	Mar. 14, 2024
7	Power Sensor	Keysight	U2021XA	MY55130006	Mar. 14, 2024
8	Wideband Radio Communication Tester	R&S	CMW500	102414	Dec. 16, 2023
9	High and low temperature box	ESPEC	MT3035	/	Mar. 24, 2024
10	JS1120 RF Test System	TONSCEND	v2.6	/	/

Radiated Emission (3m chamber 2)					
Item	Test Equipment	Manufacturer	Model No.	Serial No.	Calibrated Until
1	Trilog-Broadband Antenna	Schwarzbeck	VULB 9168	9168-1013	Dec. 07, 2024
2	Horn Antenna	Schwarzbeck	BBHA 9120D	9120D-648	Dec. 07, 2024
3	Spectrum Analyzer	R&S	FSU26	100105	Dec. 16, 2023
4	Spectrum Analyzer	R&S	FSV40-N	101331	Mar. 14, 2024
5	Pre-Amplifier	SONOMA	310	186194	Dec. 16, 2023
6	Low Noise Pre-Amplifier	EMCI	EMC051835	980075	Dec. 16, 2023
7	Test Receiver	R&S	ESC17	100967	Dec. 16, 2023
8	3m chamber 2	Frankonia	EE025	/	Oct. 23, 2024

Radiated Emission (3m chamber 3)					
Item	Test Equipment	Manufacturer	Model No.	Serial No.	Calibrated Until
1	Trilog-Broadband Antenna	Schwarzbeck	VULB 9163	01026	Dec. 18, 2024
2	Horn Antenna	Schwarzbeck	BBHA 9120D	9120D-647	Dec. 01, 2024
3	Test Receiver	Keysight	N9038A	MY56400071	Dec. 16, 2023
4	Broadband Premplifier	SCHWARZBECK	BBV9743B	259	Dec. 16, 2023
5	Mirowave Broadband Amplifier	SCHWARZBECK	BBV9718C	111	Dec. 16, 2023
6	3m chamber 3	YIHENG	EE106	/	Sep. 09, 2023

CTC Laboratories, Inc.

2/F., Building 1 and 1-2/F., Building 2, Jiaquan Building, Guanlan High-Tech Park, Longhua District, Shenzhen, Guangdong, China
Tel.: (86)755-27521059 Fax: (86)755-27521011 Http://www.sz-ctc.org.cn



For anti-fake verification, please visit the official website of Certification and Accreditation Administration of the People's Republic of China : <http://yz.cnca.cn>



Conducted Emission					
Item	Test Equipment	Manufacturer	Model No.	Serial No.	Calibrated Until
1	LISN	R&S	ENV216	101112	Dec. 16, 2023
2	LISN	R&S	ENV216	101113	Dec. 16, 2023
3	EMI Test Receiver	R&S	ESCS30	100353	Dec. 16, 2023
4	ISN CAT6	Schwarzbeck	NTFM 8158	CAT6-8158-0046	Dec. 16, 2023
5	ISN CAT5	Schwarzbeck	NTFM 8158	CAT5-8158-0046	Dec. 16, 2023

Note: 1. The Cal. Interval was one year.

2. The Cal. Interval was three years of the antenna.

3. The cable loss has been calculated in test result which connection between each test instruments.

3. TEST ITEM AND RESULTS

3.1. Conducted Emission

Limit

FCC CFR Title 47 Part 15 Subpart C Section 15.207

Frequency (MHz)	Conducted Limit (dB μ V)	
	Quasi-peak	Average
0.15 - 0.5	66 to 56 *	56 to 46 *
0.5 - 5	56	46
5 - 30	60	50

* Decreases with the logarithm of the frequency.

Test Configuration

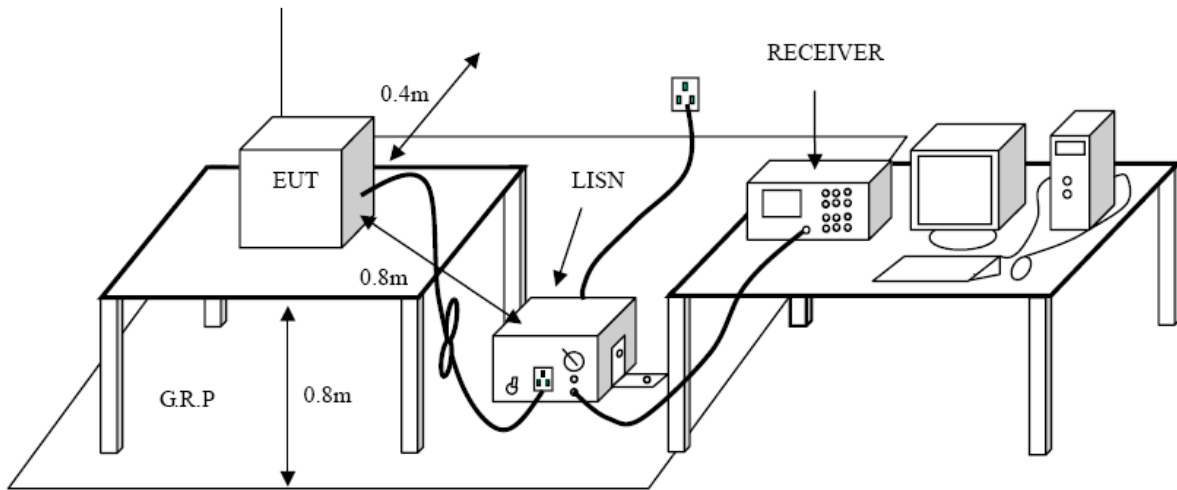

Test Procedure

1. The EUT was setup according to ANSI C63.10:2013 requirements.
2. The EUT was placed on a platform of nominal size, 1 m by 1.5 m, raised 80 cm above the conducting ground plane. The vertical conducting plane was located 40 cm to the rear of the EUT. All other surfaces of EUT were at least 80 cm from any other grounded conducting surface.
3. The EUT and simulators are connected to the main power through a line impedance stabilization network (LISN). The LISN provides a 50 ohm / 50 μ H coupling impedance for the measuring equipment.
4. The peripheral devices are also connected to the main power through a LISN. (Please refer to the block diagram of the test setup and photographs)
5. Each current-carrying conductor of the EUT power cord, except the ground (safety) conductor, was individually connected through a LISN to the input power source.
6. The excess length of the power cord between the EUT and the LISN receptacle were folded back and forth at the center of the lead to form a bundle not exceeding 40 cm in length.
7. Conducted emissions were investigated over the frequency range from 0.15MHz to 30MHz using a receiver bandwidth of 9 kHz.
8. During the above scans, the emissions were maximized by cable manipulation.

Test Mode

Please refer to the clause 2.4.



Test Result

Test Voltage:	AC 120V/60Hz
Terminal:	Line
Remark:	Only worse case is reported

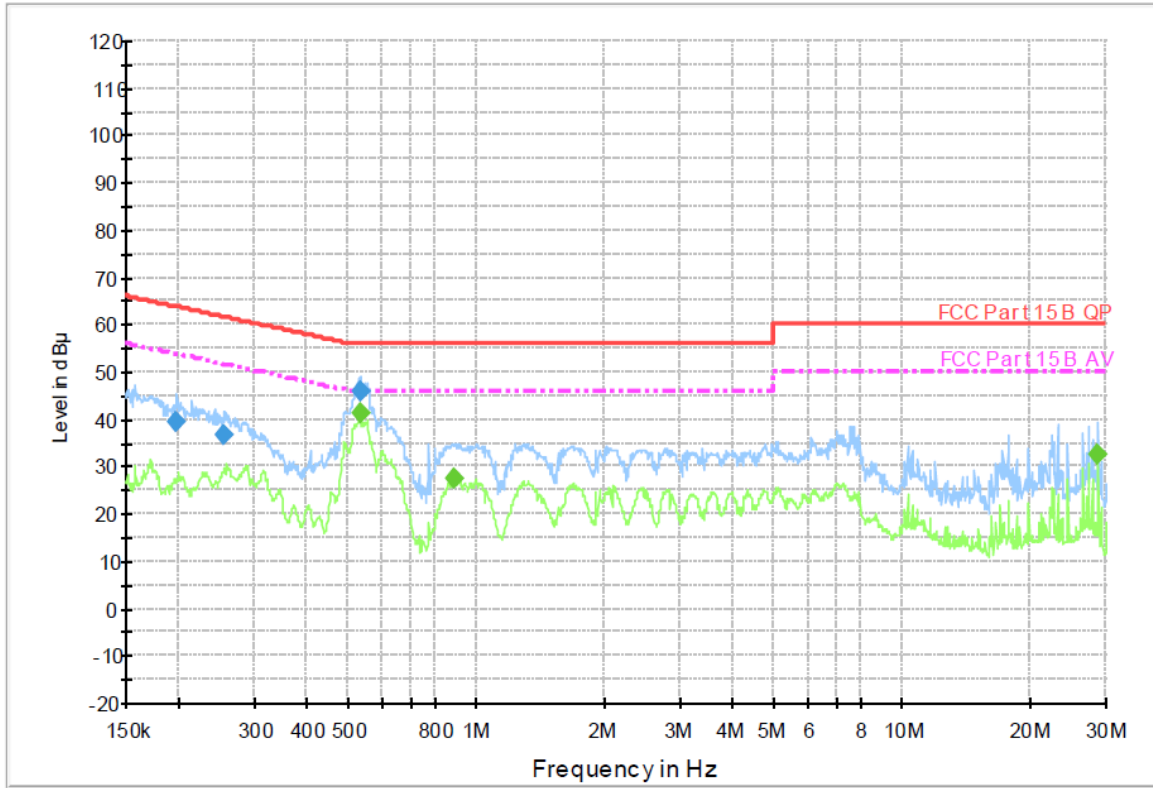

Final Measurement Detector 1

Frequency (MHz)	QuasiPeak (dBμ V)	Meas. Time (ms)	Bandwidth (kHz)	Filter	Line	Corr. (dB)	Margin (dB)	Limit (dBμ V)	Comment
0.197570	39.3	1000.00	9.000	On	L1	9.7	24.4	63.7	
0.255080	36.8	1000.00	9.000	On	L1	9.7	24.8	61.6	
0.531710	45.9	1000.00	9.000	On	L1	9.7	10.1	56.0	

Final Measurement Detector 2

Frequency (MHz)	Average (dBμ V)	Meas. Time (ms)	Bandwidth (kHz)	Filter	Line	Corr. (dB)	Margin (dB)	Limit (dBμ V)	Comment
0.531710	41.3	1000.00	9.000	On	L1	9.7	4.7	46.0	
0.886330	27.2	1000.00	9.000	On	L1	9.7	18.8	46.0	
28.685180	32.3	1000.00	9.000	On	L1	9.9	17.7	50.0	

Emission Level = Read Level + Correct Factor





Test Voltage:	AC 120V/60Hz
Terminal:	Neutral
Remark:	Only worse case is reported

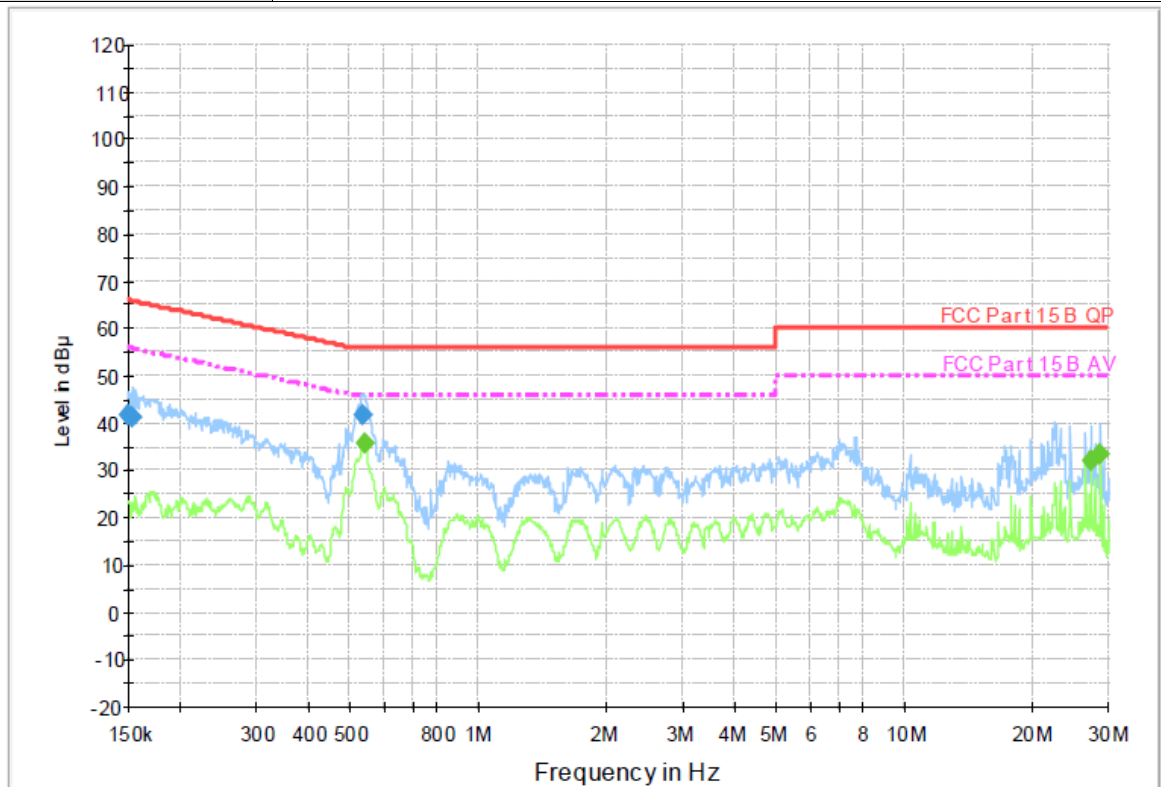

Final Measurement Detector 1

Frequency (MHz)	QuasiPeak (dBµ V)	Meas. Time (ms)	Bandwidth (kHz)	Filter	Line	Corr. (dB)	Margin (dB)	Limit (dBµ V)	Comment
0.150000	41.6	1000.00	9.000	On	N	10.0	24.4	66.0	
0.153020	41.1	1000.00	9.000	On	N	10.0	24.7	65.8	
0.535980	41.9	1000.00	9.000	On	N	10.0	14.1	56.0	

Final Measurement Detector 2

Frequency (MHz)	Average (dBµ V)	Meas. Time (ms)	Bandwidth (kHz)	Filter	Line	Corr. (dB)	Margin (dB)	Limit (dBµ V)	Comment
0.538120	35.7	1000.00	9.000	On	N	10.0	10.3	46.0	
27.343430	32.0	1000.00	9.000	On	N	10.0	18.0	50.0	
28.685180	33.3	1000.00	9.000	On	N	10.0	16.7	50.0	

Emission Level = Read Level + Correct Factor



3.2. Radiated Emission

Limit

FCC CFR Title 47 Part 15 Subpart C Section 15.209

Frequency (MHz)	Field Strength (microvolts/meter)	Measurement Distance (meters)
0.009~0.490	2400/F (kHz)	300
0.490~1.705	24000/F (kHz)	30
1.705~30.0	30	30
30~88	100	3
88~216	150	3
216~960	200	3
960~1000	500	3

Frequency Range (MHz)	dBµV/m (at 3 meters)	
	Peak	Average
Above 1000	74	54

Note:

- (1) The tighter limit applies at the band edges.
- (2) Emission Level (dBµV/m)=20log Emission Level (µV/m).

Test Configuration

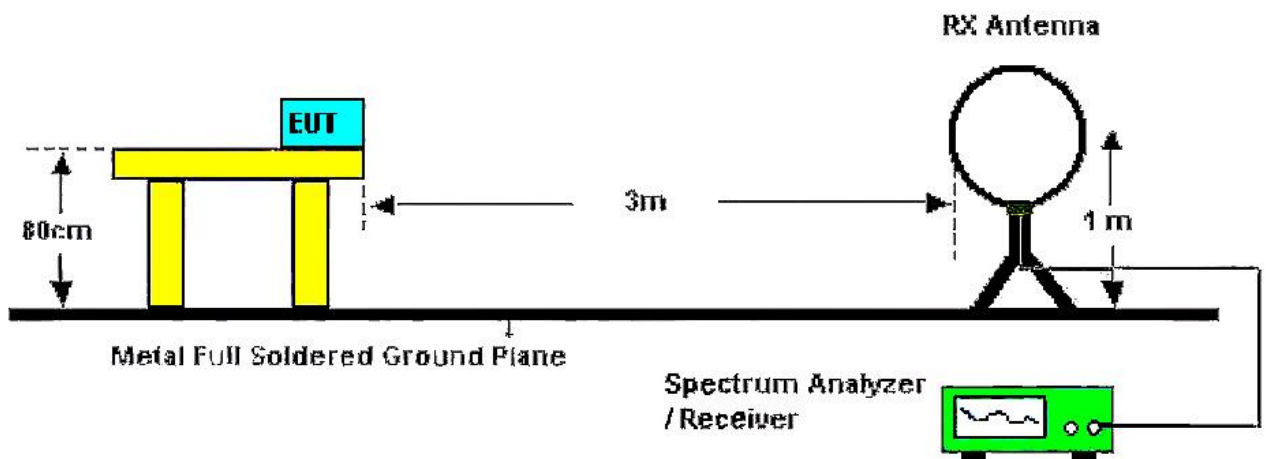

Below 30MHz Test Setup

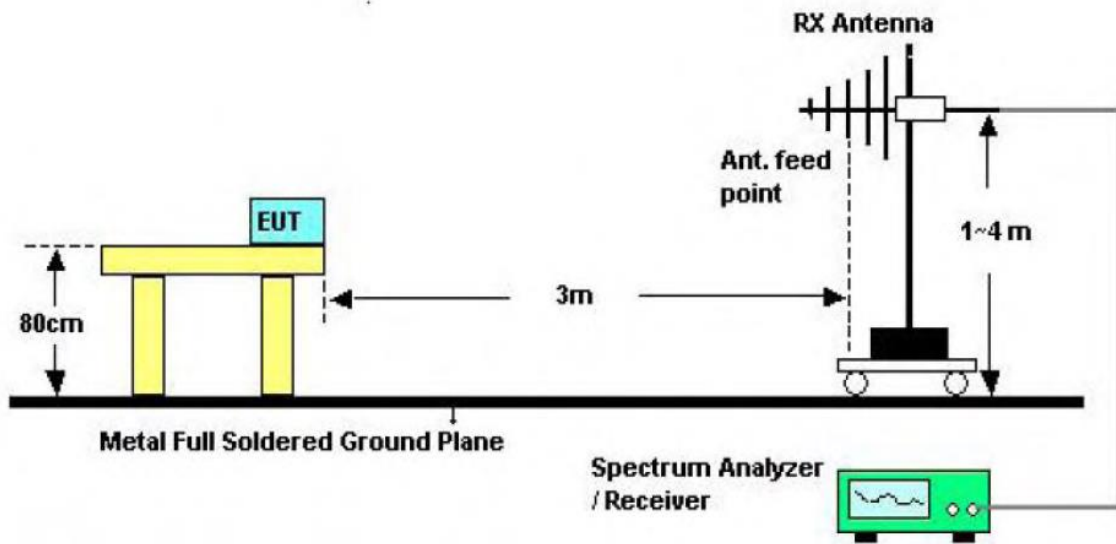

30-1000MHz Test Setup

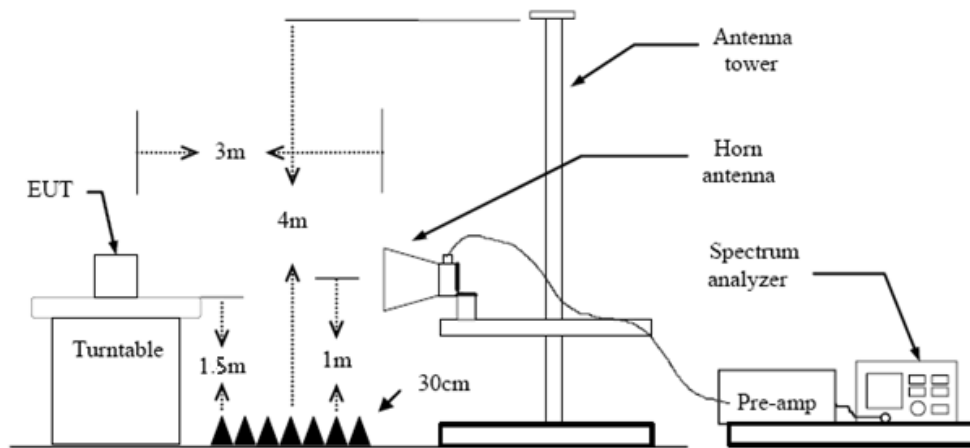

Above 1GHz Test Setup

Test Procedure

1. The EUT was setup and tested according to ANSI C63.10:2013.
2. The EUT is placed on a turn table which is 0.8 meter above ground for below 1 GHz, and 1.5 m for above 1 GHz. The turn table is rotated 360 degrees to determine the position of the maximum emission level.
3. The EUT was set 3 meters from the receiving antenna, which was mounted on the top of a variable height antenna tower.
4. For each suspected emission, the EUT was arranged to its worst case and then tune the Antenna tower (from 1 m to 4 m) and turntable (from 0 degree to 360 degrees) to find the maximum reading. A pre-amp and a high pass filter are used for the test in order to get better signal level to comply with the guidelines.
5. Set to the maximum power setting and enable the EUT transmit continuously.
6. Use the following spectrum analyzer settings
 - (1) Span shall wide enough to fully capture the emission being measured;
 - (2) Below 1 GHz:
RBW=120 kHz, VBW=300 kHz, Sweep=auto, Detector function=peak, Trace=max hold;
If the emission level of the EUT measured by the peak detector is 3 dB lower than the applicable limit, the peak emission level will be reported. Otherwise, the emission measurement will be repeated using the quasi-peak detector and reported.
 - (3) From 1 GHz to 10th harmonic:
RBW=1MHz, VBW=3MHz Peak detector for Peak value.



RBW=1MHz, VBW see note 1 with Peak Detector for Average Value.

Note 1: For measurements above 1 GHz the resolution bandwidth is set to 1 MHz, then the video bandwidth is set to 3 MHz for peak measurements and 1 MHz resolution bandwidth with 1/T video bandwidth with peak detector for average measurements. For the Duty Cycle please refer to clause 3.10 Duty Cycle.

Test Mode

Please refer to the clause 2.4.

Test Result

9 kHz~30 MHz

From 9 kHz to 30 MHz: The conclusion is PASS.

Note: The amplitude of spurious emissions which are attenuated by more than 20dB below the permissible value has no need to be reported.



30MHz-1GHz

Ant. Pol.	Horizontal
Test Mode:	TX GFSK Mode 2402MHz
Remark:	Only worse case is reported.

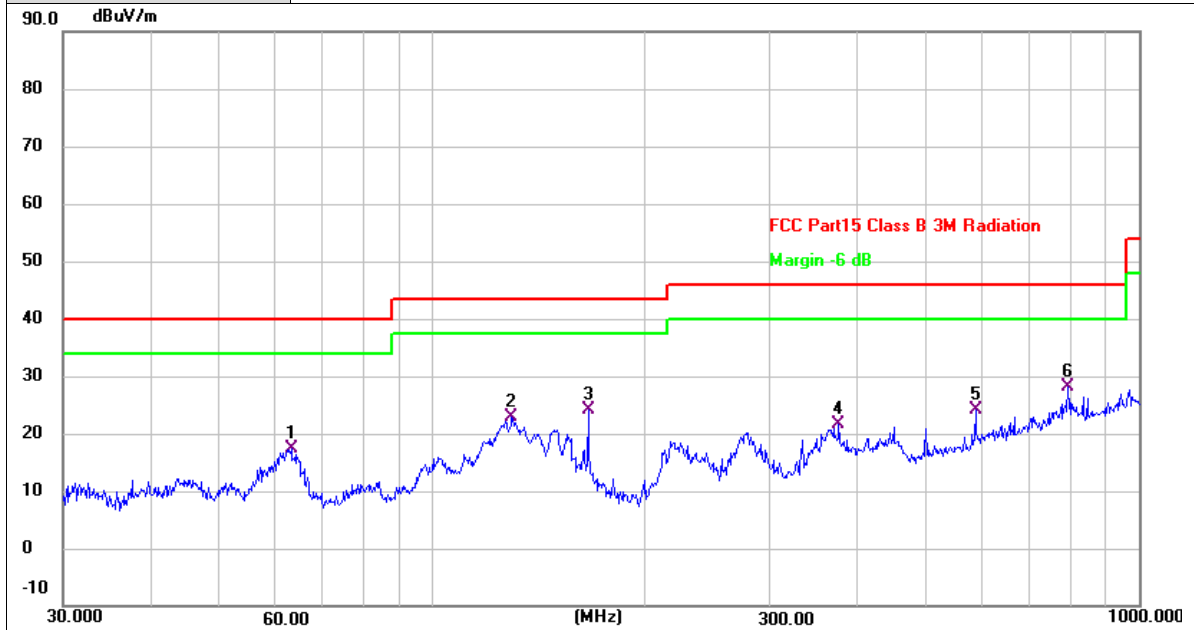

No.	Frequency (MHz)	Reading (dBuV)	Factor (dB/m)	Level (dBuV/m)	Limit (dBuV/m)	Margin (dB)	Detector
1	63.0916	36.64	-19.18	17.46	40.00	-22.54	QP
2	129.4677	41.52	-18.54	22.98	43.50	-20.52	QP
3	166.0680	41.79	-17.61	24.18	43.50	-19.32	QP
4	375.9385	36.98	-15.39	21.59	46.00	-24.41	QP
5	586.8436	35.11	-11.01	24.10	46.00	-21.90	QP
6 *	793.3958	35.55	-7.40	28.15	46.00	-17.85	QP

Remarks:

- Factor (dB/m) = Antenna Factor (dB/m)+Cable Factor (dB)-Pre-amplifier Factor
- Margin value = Level -Limit value



Ant. Pol.	Vertical
Test Mode:	TX GFSK Mode 2402MHz
Remark:	Only worse case is reported.

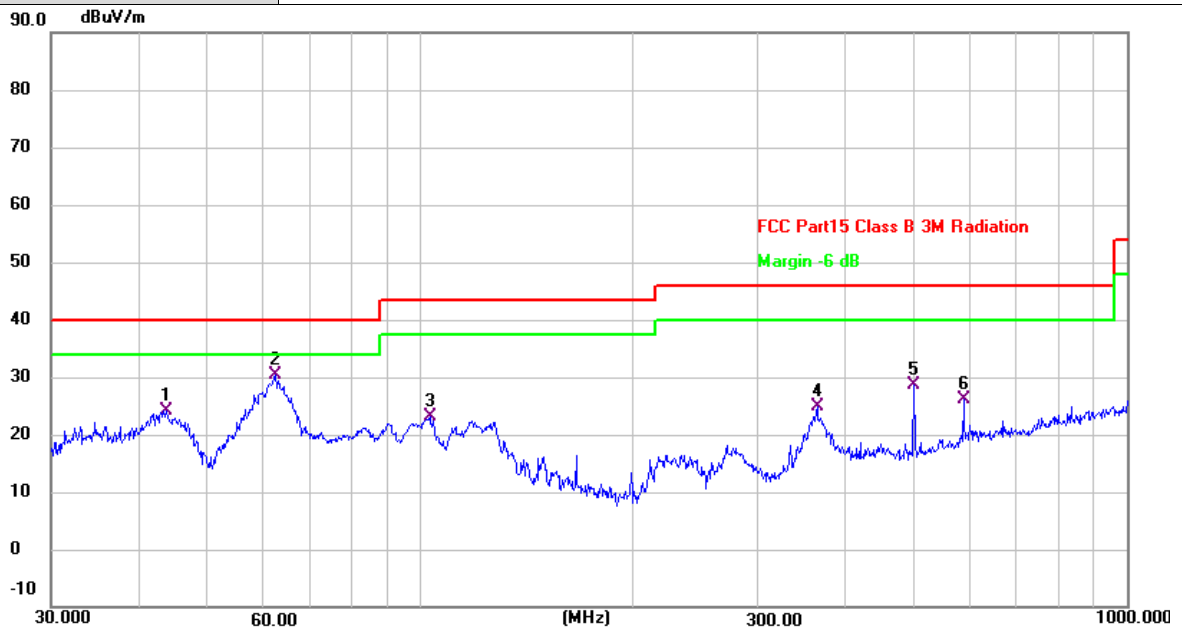

No.	Frequency (MHz)	Reading (dBuV)	Factor (dB/m)	Level (dBuV/m)	Limit (dBuV/m)	Margin (dB)	Detector
1	43.6584	41.86	-17.64	24.22	40.00	-15.78	QP
2 *	62.4314	49.46	-19.05	30.41	40.00	-9.59	QP
3	103.0800	43.61	-20.59	23.02	43.50	-20.48	QP
4	364.2595	40.45	-15.64	24.81	46.00	-21.19	QP
5	499.4247	41.29	-12.67	28.62	46.00	-17.38	QP
6	586.8437	37.20	-11.01	26.19	46.00	-19.81	QP

Remarks:

- 1. Factor (dB/m) = Antenna Factor (dB/m)+Cable Factor (dB)-Pre-amplifier Factor
- 2. Margin value = Level -Limit value





Above 1GHz

Ant. Pol.	Horizontal																														
Test Mode:	TX GFSK Mode 2402MHz																														
Remark:	No report for the emission which more than 20 dB below the prescribed limit.																														
<table border="1"> <thead> <tr> <th>No.</th> <th>Frequency (MHz)</th> <th>Reading (dBuV)</th> <th>Factor (dB/m)</th> <th>Level (dBuV/m)</th> <th>Limit (dBuV/m)</th> <th>Margin (dB)</th> <th>Detector</th> </tr> </thead> <tbody> <tr> <td>1</td> <td>4804.011</td> <td>48.04</td> <td>-2.44</td> <td>45.60</td> <td>74.00</td> <td>-28.40</td> <td>peak</td> </tr> <tr> <td>2 *</td> <td>4804.325</td> <td>35.20</td> <td>-2.44</td> <td>32.76</td> <td>54.00</td> <td>-21.24</td> <td>AVG</td> </tr> </tbody> </table>								No.	Frequency (MHz)	Reading (dBuV)	Factor (dB/m)	Level (dBuV/m)	Limit (dBuV/m)	Margin (dB)	Detector	1	4804.011	48.04	-2.44	45.60	74.00	-28.40	peak	2 *	4804.325	35.20	-2.44	32.76	54.00	-21.24	AVG
No.	Frequency (MHz)	Reading (dBuV)	Factor (dB/m)	Level (dBuV/m)	Limit (dBuV/m)	Margin (dB)	Detector																								
1	4804.011	48.04	-2.44	45.60	74.00	-28.40	peak																								
2 *	4804.325	35.20	-2.44	32.76	54.00	-21.24	AVG																								
Remarks: 1.Factor (dB/m) = Antenna Factor (dB/m)+Cable Factor (dB)-Pre-amplifier Factor 2.Margin value = Level -Limit value																															

Ant. Pol.	Vertical																														
Test Mode:	TX GFSK Mode 2402MHz																														
Remark:	No report for the emission which more than 20 dB below the prescribed limit.																														
<table border="1"> <thead> <tr> <th>No.</th> <th>Frequency (MHz)</th> <th>Reading (dBuV)</th> <th>Factor (dB/m)</th> <th>Level (dBuV/m)</th> <th>Limit (dBuV/m)</th> <th>Margin (dB)</th> <th>Detector</th> </tr> </thead> <tbody> <tr> <td>1</td> <td>4803.258</td> <td>44.21</td> <td>-2.44</td> <td>41.77</td> <td>74.00</td> <td>-32.23</td> <td>peak</td> </tr> <tr> <td>2 *</td> <td>4803.458</td> <td>33.54</td> <td>-2.44</td> <td>31.10</td> <td>54.00</td> <td>-22.90</td> <td>AVG</td> </tr> </tbody> </table>								No.	Frequency (MHz)	Reading (dBuV)	Factor (dB/m)	Level (dBuV/m)	Limit (dBuV/m)	Margin (dB)	Detector	1	4803.258	44.21	-2.44	41.77	74.00	-32.23	peak	2 *	4803.458	33.54	-2.44	31.10	54.00	-22.90	AVG
No.	Frequency (MHz)	Reading (dBuV)	Factor (dB/m)	Level (dBuV/m)	Limit (dBuV/m)	Margin (dB)	Detector																								
1	4803.258	44.21	-2.44	41.77	74.00	-32.23	peak																								
2 *	4803.458	33.54	-2.44	31.10	54.00	-22.90	AVG																								
Remarks: 1.Factor (dB/m) = Antenna Factor (dB/m)+Cable Factor (dB)-Pre-amplifier Factor 2.Margin value = Level -Limit value																															



Ant. Pol.	Horizontal																														
Test Mode:	TX GFSK Mode 2441MHz																														
Remark:	No report for the emission which more than 20 dB below the prescribed limit.																														
<table border="1"> <thead> <tr> <th>No.</th> <th>Frequency (MHz)</th> <th>Reading (dBuV)</th> <th>Factor (dB/m)</th> <th>Level (dBuV/m)</th> <th>Limit (dBuV/m)</th> <th>Margin (dB)</th> <th>Detector</th> </tr> </thead> <tbody> <tr> <td>1 *</td> <td>4882.866</td> <td>34.22</td> <td>-2.09</td> <td>32.13</td> <td>54.00</td> <td>-21.87</td> <td>AVG</td> </tr> <tr> <td>2</td> <td>4882.880</td> <td>48.82</td> <td>-2.09</td> <td>46.73</td> <td>74.00</td> <td>-27.27</td> <td>peak</td> </tr> </tbody> </table>								No.	Frequency (MHz)	Reading (dBuV)	Factor (dB/m)	Level (dBuV/m)	Limit (dBuV/m)	Margin (dB)	Detector	1 *	4882.866	34.22	-2.09	32.13	54.00	-21.87	AVG	2	4882.880	48.82	-2.09	46.73	74.00	-27.27	peak
No.	Frequency (MHz)	Reading (dBuV)	Factor (dB/m)	Level (dBuV/m)	Limit (dBuV/m)	Margin (dB)	Detector																								
1 *	4882.866	34.22	-2.09	32.13	54.00	-21.87	AVG																								
2	4882.880	48.82	-2.09	46.73	74.00	-27.27	peak																								
Remarks: 1.Factor (dB/m) = Antenna Factor (dB/m)+Cable Factor (dB)-Pre-amplifier Factor 2.Margin value = Level -Limit value																															

Ant. Pol.	Vertical																														
Test Mode:	TX GFSK Mode 2441MHz																														
Remark:	No report for the emission which more than 20 dB below the prescribed limit.																														
<table border="1"> <thead> <tr> <th>No.</th> <th>Frequency (MHz)</th> <th>Reading (dBuV)</th> <th>Factor (dB/m)</th> <th>Level (dBuV/m)</th> <th>Limit (dBuV/m)</th> <th>Margin (dB)</th> <th>Detector</th> </tr> </thead> <tbody> <tr> <td>1</td> <td>4881.853</td> <td>45.24</td> <td>-2.11</td> <td>43.13</td> <td>74.00</td> <td>-30.87</td> <td>peak</td> </tr> <tr> <td>2 *</td> <td>4882.645</td> <td>33.42</td> <td>-2.10</td> <td>31.32</td> <td>54.00</td> <td>-22.68</td> <td>AVG</td> </tr> </tbody> </table>								No.	Frequency (MHz)	Reading (dBuV)	Factor (dB/m)	Level (dBuV/m)	Limit (dBuV/m)	Margin (dB)	Detector	1	4881.853	45.24	-2.11	43.13	74.00	-30.87	peak	2 *	4882.645	33.42	-2.10	31.32	54.00	-22.68	AVG
No.	Frequency (MHz)	Reading (dBuV)	Factor (dB/m)	Level (dBuV/m)	Limit (dBuV/m)	Margin (dB)	Detector																								
1	4881.853	45.24	-2.11	43.13	74.00	-30.87	peak																								
2 *	4882.645	33.42	-2.10	31.32	54.00	-22.68	AVG																								
Remarks: 1.Factor (dB/m) = Antenna Factor (dB/m)+Cable Factor (dB)-Pre-amplifier Factor 2.Margin value = Level -Limit value																															



Ant. Pol.	Horizontal																														
Test Mode:	TX GFSK Mode 2480MHz																														
Remark:	No report for the emission which more than 20 dB below the prescribed limit.																														
<table border="1"> <thead> <tr> <th>No.</th> <th>Frequency (MHz)</th> <th>Reading (dBuV)</th> <th>Factor (dB/m)</th> <th>Level (dBuV/m)</th> <th>Limit (dBuV/m)</th> <th>Margin (dB)</th> <th>Detector</th> </tr> </thead> <tbody> <tr> <td>1 *</td> <td>4960.149</td> <td>34.05</td> <td>-1.77</td> <td>32.28</td> <td>54.00</td> <td>-21.72</td> <td>AVG</td> </tr> <tr> <td>2</td> <td>4960.890</td> <td>48.63</td> <td>-1.77</td> <td>46.86</td> <td>74.00</td> <td>-27.14</td> <td>peak</td> </tr> </tbody> </table>								No.	Frequency (MHz)	Reading (dBuV)	Factor (dB/m)	Level (dBuV/m)	Limit (dBuV/m)	Margin (dB)	Detector	1 *	4960.149	34.05	-1.77	32.28	54.00	-21.72	AVG	2	4960.890	48.63	-1.77	46.86	74.00	-27.14	peak
No.	Frequency (MHz)	Reading (dBuV)	Factor (dB/m)	Level (dBuV/m)	Limit (dBuV/m)	Margin (dB)	Detector																								
1 *	4960.149	34.05	-1.77	32.28	54.00	-21.72	AVG																								
2	4960.890	48.63	-1.77	46.86	74.00	-27.14	peak																								
Remarks: 1. Factor (dB/m) = Antenna Factor (dB/m)+Cable Factor (dB)-Pre-amplifier Factor 2. Margin value = Level -Limit value																															

Ant. Pol.	Vertical																														
Test Mode:	TX GFSK Mode 2480MHz																														
Remark:	No report for the emission which more than 20 dB below the prescribed limit.																														
<table border="1"> <thead> <tr> <th>No.</th> <th>Frequency (MHz)</th> <th>Reading (dBuV)</th> <th>Factor (dB/m)</th> <th>Level (dBuV/m)</th> <th>Limit (dBuV/m)</th> <th>Margin (dB)</th> <th>Detector</th> </tr> </thead> <tbody> <tr> <td>1</td> <td>4959.570</td> <td>43.73</td> <td>-1.78</td> <td>41.95</td> <td>74.00</td> <td>-32.05</td> <td>peak</td> </tr> <tr> <td>2 *</td> <td>4959.862</td> <td>33.41</td> <td>-1.77</td> <td>31.64</td> <td>54.00</td> <td>-22.36</td> <td>AVG</td> </tr> </tbody> </table>								No.	Frequency (MHz)	Reading (dBuV)	Factor (dB/m)	Level (dBuV/m)	Limit (dBuV/m)	Margin (dB)	Detector	1	4959.570	43.73	-1.78	41.95	74.00	-32.05	peak	2 *	4959.862	33.41	-1.77	31.64	54.00	-22.36	AVG
No.	Frequency (MHz)	Reading (dBuV)	Factor (dB/m)	Level (dBuV/m)	Limit (dBuV/m)	Margin (dB)	Detector																								
1	4959.570	43.73	-1.78	41.95	74.00	-32.05	peak																								
2 *	4959.862	33.41	-1.77	31.64	54.00	-22.36	AVG																								
Remarks: 1. Factor (dB/m) = Antenna Factor (dB/m)+Cable Factor (dB)-Pre-amplifier Factor 2. Margin value = Level -Limit value																															



Ant. Pol.	Horizontal																														
Test Mode:	TX $\pi/4$ -DQPSK Mode 2402MHz																														
Remark:	No report for the emission which more than 20 dB below the prescribed limit.																														
<table border="1"> <thead> <tr> <th>No.</th> <th>Frequency (MHz)</th> <th>Reading (dBuV)</th> <th>Factor (dB/m)</th> <th>Level (dBuV/m)</th> <th>Limit (dBuV/m)</th> <th>Margin (dB)</th> <th>Detector</th> </tr> </thead> <tbody> <tr> <td>1</td> <td>4803.176</td> <td>48.18</td> <td>-2.44</td> <td>45.74</td> <td>74.00</td> <td>-28.26</td> <td>peak</td> </tr> <tr> <td>2 *</td> <td>4803.914</td> <td>35.40</td> <td>-2.44</td> <td>32.96</td> <td>54.00</td> <td>-21.04</td> <td>AVG</td> </tr> </tbody> </table>								No.	Frequency (MHz)	Reading (dBuV)	Factor (dB/m)	Level (dBuV/m)	Limit (dBuV/m)	Margin (dB)	Detector	1	4803.176	48.18	-2.44	45.74	74.00	-28.26	peak	2 *	4803.914	35.40	-2.44	32.96	54.00	-21.04	AVG
No.	Frequency (MHz)	Reading (dBuV)	Factor (dB/m)	Level (dBuV/m)	Limit (dBuV/m)	Margin (dB)	Detector																								
1	4803.176	48.18	-2.44	45.74	74.00	-28.26	peak																								
2 *	4803.914	35.40	-2.44	32.96	54.00	-21.04	AVG																								
Remarks: 1.Factor (dB/m) = Antenna Factor (dB/m)+Cable Factor (dB)-Pre-amplifier Factor 2.Margin value = Level -Limit value																															

Ant. Pol.	Vertical																														
Test Mode:	TX $\pi/4$ -DQPSK Mode 2402MHz																														
Remark:	No report for the emission which more than 20 dB below the prescribed limit.																														
<table border="1"> <thead> <tr> <th>No.</th> <th>Frequency (MHz)</th> <th>Reading (dBuV)</th> <th>Factor (dB/m)</th> <th>Level (dBuV/m)</th> <th>Limit (dBuV/m)</th> <th>Margin (dB)</th> <th>Detector</th> </tr> </thead> <tbody> <tr> <td>1 *</td> <td>4803.146</td> <td>33.53</td> <td>-2.44</td> <td>31.09</td> <td>54.00</td> <td>-22.91</td> <td>AVG</td> </tr> <tr> <td>2</td> <td>4803.963</td> <td>45.07</td> <td>-2.44</td> <td>42.63</td> <td>74.00</td> <td>-31.37</td> <td>peak</td> </tr> </tbody> </table>								No.	Frequency (MHz)	Reading (dBuV)	Factor (dB/m)	Level (dBuV/m)	Limit (dBuV/m)	Margin (dB)	Detector	1 *	4803.146	33.53	-2.44	31.09	54.00	-22.91	AVG	2	4803.963	45.07	-2.44	42.63	74.00	-31.37	peak
No.	Frequency (MHz)	Reading (dBuV)	Factor (dB/m)	Level (dBuV/m)	Limit (dBuV/m)	Margin (dB)	Detector																								
1 *	4803.146	33.53	-2.44	31.09	54.00	-22.91	AVG																								
2	4803.963	45.07	-2.44	42.63	74.00	-31.37	peak																								
Remarks: 1.Factor (dB/m) = Antenna Factor (dB/m)+Cable Factor (dB)-Pre-amplifier Factor 2.Margin value = Level -Limit value																															



Ant. Pol.	Horizontal																														
Test Mode:	TX $\pi/4$ -DQPSK Mode 2441MHz																														
Remark:	No report for the emission which more than 20 dB below the prescribed limit.																														
<table border="1"> <thead> <tr> <th>No.</th> <th>Frequency (MHz)</th> <th>Reading (dBuV)</th> <th>Factor (dB/m)</th> <th>Level (dBuV/m)</th> <th>Limit (dBuV/m)</th> <th>Margin (dB)</th> <th>Detector</th> </tr> </thead> <tbody> <tr> <td>1 *</td> <td>4881.390</td> <td>34.19</td> <td>-2.11</td> <td>32.08</td> <td>54.00</td> <td>-21.92</td> <td>AVG</td> </tr> <tr> <td>2</td> <td>4881.432</td> <td>48.12</td> <td>-2.11</td> <td>46.01</td> <td>74.00</td> <td>-27.99</td> <td>peak</td> </tr> </tbody> </table>								No.	Frequency (MHz)	Reading (dBuV)	Factor (dB/m)	Level (dBuV/m)	Limit (dBuV/m)	Margin (dB)	Detector	1 *	4881.390	34.19	-2.11	32.08	54.00	-21.92	AVG	2	4881.432	48.12	-2.11	46.01	74.00	-27.99	peak
No.	Frequency (MHz)	Reading (dBuV)	Factor (dB/m)	Level (dBuV/m)	Limit (dBuV/m)	Margin (dB)	Detector																								
1 *	4881.390	34.19	-2.11	32.08	54.00	-21.92	AVG																								
2	4881.432	48.12	-2.11	46.01	74.00	-27.99	peak																								
Remarks: 1.Factor (dB/m) = Antenna Factor (dB/m)+Cable Factor (dB)-Pre-amplifier Factor 2.Margin value = Level -Limit value																															

Ant. Pol.	Vertical																														
Test Mode:	TX $\pi/4$ -DQPSK Mode 2441MHz																														
Remark:	No report for the emission which more than 20 dB below the prescribed limit.																														
<table border="1"> <thead> <tr> <th>No.</th> <th>Frequency (MHz)</th> <th>Reading (dBuV)</th> <th>Factor (dB/m)</th> <th>Level (dBuV/m)</th> <th>Limit (dBuV/m)</th> <th>Margin (dB)</th> <th>Detector</th> </tr> </thead> <tbody> <tr> <td>1</td> <td>4881.098</td> <td>46.08</td> <td>-2.11</td> <td>43.97</td> <td>74.00</td> <td>-30.03</td> <td>peak</td> </tr> <tr> <td>2 *</td> <td>4882.483</td> <td>34.31</td> <td>-2.11</td> <td>32.20</td> <td>54.00</td> <td>-21.80</td> <td>AVG</td> </tr> </tbody> </table>								No.	Frequency (MHz)	Reading (dBuV)	Factor (dB/m)	Level (dBuV/m)	Limit (dBuV/m)	Margin (dB)	Detector	1	4881.098	46.08	-2.11	43.97	74.00	-30.03	peak	2 *	4882.483	34.31	-2.11	32.20	54.00	-21.80	AVG
No.	Frequency (MHz)	Reading (dBuV)	Factor (dB/m)	Level (dBuV/m)	Limit (dBuV/m)	Margin (dB)	Detector																								
1	4881.098	46.08	-2.11	43.97	74.00	-30.03	peak																								
2 *	4882.483	34.31	-2.11	32.20	54.00	-21.80	AVG																								
Remarks: 1.Factor (dB/m) = Antenna Factor (dB/m)+Cable Factor (dB)-Pre-amplifier Factor 2.Margin value = Level -Limit value																															



Ant. Pol.	Horizontal																														
Test Mode:	TX $\pi/4$ -DQPSK Mode 2480MHz																														
Remark:	No report for the emission which more than 20 dB below the prescribed limit.																														
<table border="1"> <thead> <tr> <th>No.</th> <th>Frequency (MHz)</th> <th>Reading (dBuV)</th> <th>Factor (dB/m)</th> <th>Level (dBuV/m)</th> <th>Limit (dBuV/m)</th> <th>Margin (dB)</th> <th>Detector</th> </tr> </thead> <tbody> <tr> <td>1</td> <td>4959.219</td> <td>48.03</td> <td>-1.78</td> <td>46.25</td> <td>74.00</td> <td>-27.75</td> <td>peak</td> </tr> <tr> <td>2 *</td> <td>4960.925</td> <td>33.96</td> <td>-1.77</td> <td>32.19</td> <td>54.00</td> <td>-21.81</td> <td>AVG</td> </tr> </tbody> </table>								No.	Frequency (MHz)	Reading (dBuV)	Factor (dB/m)	Level (dBuV/m)	Limit (dBuV/m)	Margin (dB)	Detector	1	4959.219	48.03	-1.78	46.25	74.00	-27.75	peak	2 *	4960.925	33.96	-1.77	32.19	54.00	-21.81	AVG
No.	Frequency (MHz)	Reading (dBuV)	Factor (dB/m)	Level (dBuV/m)	Limit (dBuV/m)	Margin (dB)	Detector																								
1	4959.219	48.03	-1.78	46.25	74.00	-27.75	peak																								
2 *	4960.925	33.96	-1.77	32.19	54.00	-21.81	AVG																								
Remarks: 1.Factor (dB/m) = Antenna Factor (dB/m)+Cable Factor (dB)-Pre-amplifier Factor 2.Margin value = Level -Limit value																															

Ant. Pol.	Vertical																														
Test Mode:	TX $\pi/4$ -DQPSK Mode 2480MHz																														
Remark:	No report for the emission which more than 20 dB below the prescribed limit.																														
<table border="1"> <thead> <tr> <th>No.</th> <th>Frequency (MHz)</th> <th>Reading (dBuV)</th> <th>Factor (dB/m)</th> <th>Level (dBuV/m)</th> <th>Limit (dBuV/m)</th> <th>Margin (dB)</th> <th>Detector</th> </tr> </thead> <tbody> <tr> <td>1 *</td> <td>4959.491</td> <td>33.68</td> <td>-1.78</td> <td>31.90</td> <td>54.00</td> <td>-22.10</td> <td>AVG</td> </tr> <tr> <td>2</td> <td>4959.963</td> <td>44.34</td> <td>-1.77</td> <td>42.57</td> <td>74.00</td> <td>-31.43</td> <td>peak</td> </tr> </tbody> </table>								No.	Frequency (MHz)	Reading (dBuV)	Factor (dB/m)	Level (dBuV/m)	Limit (dBuV/m)	Margin (dB)	Detector	1 *	4959.491	33.68	-1.78	31.90	54.00	-22.10	AVG	2	4959.963	44.34	-1.77	42.57	74.00	-31.43	peak
No.	Frequency (MHz)	Reading (dBuV)	Factor (dB/m)	Level (dBuV/m)	Limit (dBuV/m)	Margin (dB)	Detector																								
1 *	4959.491	33.68	-1.78	31.90	54.00	-22.10	AVG																								
2	4959.963	44.34	-1.77	42.57	74.00	-31.43	peak																								
Remarks: 1.Factor (dB/m) = Antenna Factor (dB/m)+Cable Factor (dB)-Pre-amplifier Factor 2.Margin value = Level -Limit value																															



Ant. Pol.	Horizontal																														
Test Mode:	TX 8-DPSK Mode 2402MHz																														
Remark:	No report for the emission which more than 20 dB below the prescribed limit.																														
<table border="1"> <thead> <tr> <th>No.</th> <th>Frequency (MHz)</th> <th>Reading (dBuV)</th> <th>Factor (dB/m)</th> <th>Level (dBuV/m)</th> <th>Limit (dBuV/m)</th> <th>Margin (dB)</th> <th>Detector</th> </tr> </thead> <tbody> <tr> <td>1</td> <td>4803.880</td> <td>47.80</td> <td>-2.44</td> <td>45.36</td> <td>74.00</td> <td>-28.64</td> <td>peak</td> </tr> <tr> <td>2 *</td> <td>4803.912</td> <td>35.11</td> <td>-2.44</td> <td>32.67</td> <td>54.00</td> <td>-21.33</td> <td>AVG</td> </tr> </tbody> </table>								No.	Frequency (MHz)	Reading (dBuV)	Factor (dB/m)	Level (dBuV/m)	Limit (dBuV/m)	Margin (dB)	Detector	1	4803.880	47.80	-2.44	45.36	74.00	-28.64	peak	2 *	4803.912	35.11	-2.44	32.67	54.00	-21.33	AVG
No.	Frequency (MHz)	Reading (dBuV)	Factor (dB/m)	Level (dBuV/m)	Limit (dBuV/m)	Margin (dB)	Detector																								
1	4803.880	47.80	-2.44	45.36	74.00	-28.64	peak																								
2 *	4803.912	35.11	-2.44	32.67	54.00	-21.33	AVG																								
Remarks: 1.Factor (dB/m) = Antenna Factor (dB/m)+Cable Factor (dB)-Pre-amplifier Factor 2.Margin value = Level -Limit value																															

Ant. Pol.	Vertical																														
Test Mode:	TX 8-DPSK Mode 2402MHz																														
Remark:	No report for the emission which more than 20 dB below the prescribed limit.																														
<table border="1"> <thead> <tr> <th>No.</th> <th>Frequency (MHz)</th> <th>Reading (dBuV)</th> <th>Factor (dB/m)</th> <th>Level (dBuV/m)</th> <th>Limit (dBuV/m)</th> <th>Margin (dB)</th> <th>Detector</th> </tr> </thead> <tbody> <tr> <td>1</td> <td>4803.278</td> <td>47.32</td> <td>-2.44</td> <td>44.88</td> <td>74.00</td> <td>-29.12</td> <td>peak</td> </tr> <tr> <td>2 *</td> <td>4804.373</td> <td>33.84</td> <td>-2.44</td> <td>31.40</td> <td>54.00</td> <td>-22.60</td> <td>AVG</td> </tr> </tbody> </table>								No.	Frequency (MHz)	Reading (dBuV)	Factor (dB/m)	Level (dBuV/m)	Limit (dBuV/m)	Margin (dB)	Detector	1	4803.278	47.32	-2.44	44.88	74.00	-29.12	peak	2 *	4804.373	33.84	-2.44	31.40	54.00	-22.60	AVG
No.	Frequency (MHz)	Reading (dBuV)	Factor (dB/m)	Level (dBuV/m)	Limit (dBuV/m)	Margin (dB)	Detector																								
1	4803.278	47.32	-2.44	44.88	74.00	-29.12	peak																								
2 *	4804.373	33.84	-2.44	31.40	54.00	-22.60	AVG																								
Remarks: 1.Factor (dB/m) = Antenna Factor (dB/m)+Cable Factor (dB)-Pre-amplifier Factor 2.Margin value = Level -Limit value																															



Ant. Pol.	Horizontal
Test Mode:	TX 8-DPSK Mode 2441MHz
Remark:	No report for the emission which more than 20 dB below the prescribed limit.

No.	Frequency (MHz)	Reading (dBuV)	Factor (dB/m)	Level (dBuV/m)	Limit (dBuV/m)	Margin (dB)	Detector
1 *	4881.997	34.38	-2.11	32.27	54.00	-21.73	AVG
2	4882.192	47.28	-2.11	45.17	74.00	-28.83	peak

Remarks:

1.Factor (dB/m) = Antenna Factor (dB/m)+Cable Factor (dB)-Pre-amplifier Factor

2.Margin value = Level -Limit value

Ant. Pol.	Vertical
Test Mode:	TX 8-DPSK Mode 2441MHz
Remark:	No report for the emission which more than 20 dB below the prescribed limit.

No.	Frequency (MHz)	Reading (dBuV)	Factor (dB/m)	Level (dBuV/m)	Limit (dBuV/m)	Margin (dB)	Detector
1	4882.810	44.42	-2.09	42.33	74.00	-31.67	peak
2 *	4882.963	33.43	-2.09	31.34	54.00	-22.66	AVG

Remarks:

1.Factor (dB/m) = Antenna Factor (dB/m)+Cable Factor (dB)-Pre-amplifier Factor

2.Margin value = Level -Limit value



Ant. Pol.	Horizontal
Test Mode:	TX 8-DPSK Mode 2480MHz
Remark:	No report for the emission which more than 20 dB below the prescribed limit.

No.	Frequency (MHz)	Reading (dBuV)	Factor (dB/m)	Level (dBuV/m)	Limit (dBuV/m)	Margin (dB)	Detector
1 *	4959.261	34.04	-1.78	32.26	54.00	-21.74	AVG
2	4959.443	47.59	-1.78	45.81	74.00	-28.19	peak

Remarks:

1.Factor (dB/m) = Antenna Factor (dB/m)+Cable Factor (dB)-Pre-amplifier Factor

2.Margin value = Level -Limit value

Ant. Pol.	Vertical
Test Mode:	TX 8-DPSK Mode 2480MHz
Remark:	No report for the emission which more than 20 dB below the prescribed limit.

No.	Frequency (MHz)	Reading (dBuV)	Factor (dB/m)	Level (dBuV/m)	Limit (dBuV/m)	Margin (dB)	Detector
1	4959.984	49.28	-1.77	47.51	74.00	-26.49	peak
2 *	4960.077	34.22	-1.77	32.45	54.00	-21.55	AVG

Remarks:

1.Factor (dB/m) = Antenna Factor (dB/m)+Cable Factor (dB)-Pre-amplifier Factor

2.Margin value = Level -Limit value

3.3. Band Edge Emissions (Radiated)

Limit

FCC CFR Title 47 Part 15 Subpart C Section 15.247 (d)

Restricted Frequency Band (MHz)	(dB μ V/m) (at 3m)	
	Peak	Average
2310 ~ 2390	74	54
2483.5 ~ 2500	74	54

Test Configuration

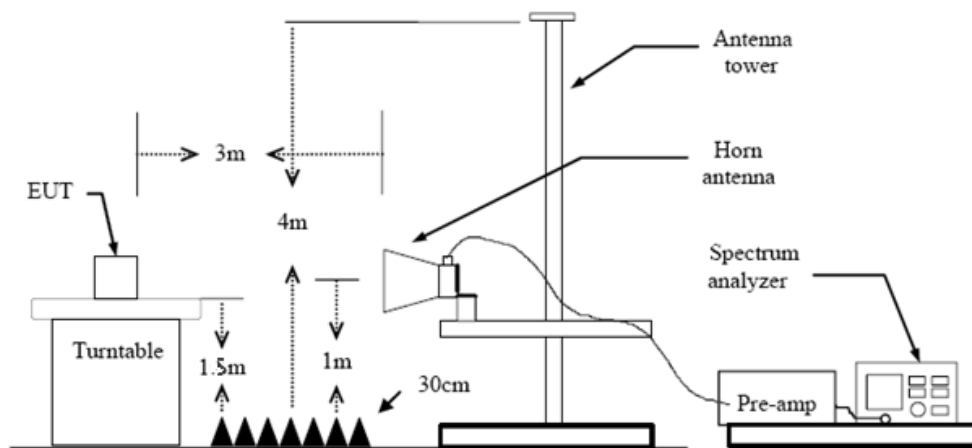

Test Procedure

1. The EUT was setup and tested according to ANSI C63.10:2013 requirements.
2. The EUT is placed on a turn table which is 1.5 meter above ground. The turn table is rotated 360 degrees to determine the position of the maximum emission level.
3. The EUT was positioned such that the distance from antenna to the EUT was 3 meters.
4. The antenna is scanned from 1 meter to 4 meters to find out the maximum emission level. This is repeated for both horizontal and vertical polarization of the antenna. In order to find the maximum emission, all of the interface cables were manipulated according to ANSI C63.10:2013 on radiated measurement.
5. The receiver set as follow:

RBW=1MHz, VBW=3MHz Peak detector for Peak value.
 RBW=1MHz, VBW see note 1 with Peak Detector for Average Value.

Note 1: For measurements, above 1 GHz the resolution bandwidth is set to 1 MHz, then the video bandwidth is set to 3 MHz for peak measurements and 1 MHz resolution bandwidth with 1/T video bandwidth with peak detector for average measurements. For the Duty Cycle please refer to clause 3.10 Duty Cycle.

Test Mode

Please refer to the clause 2.4.



Test Result

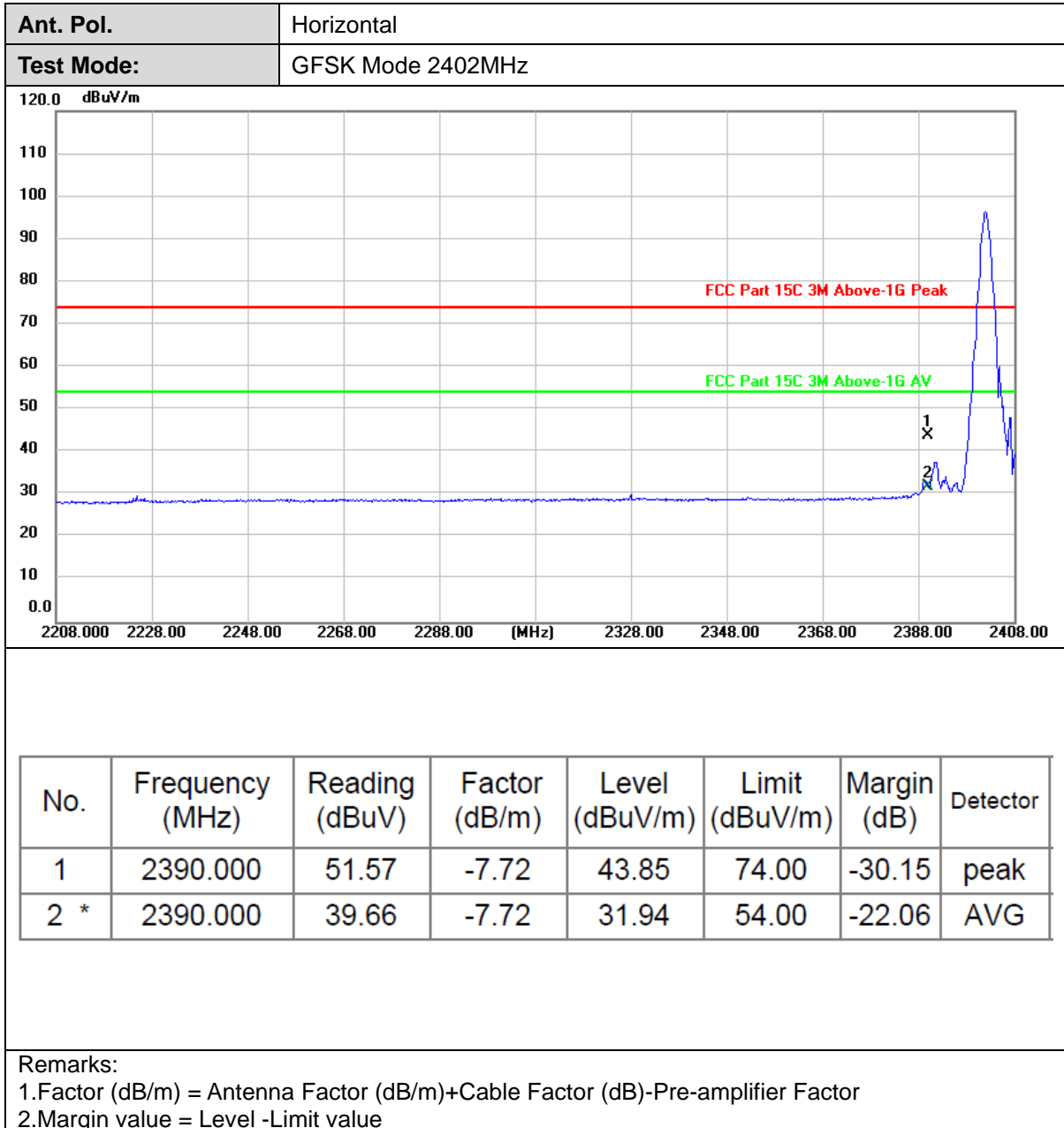

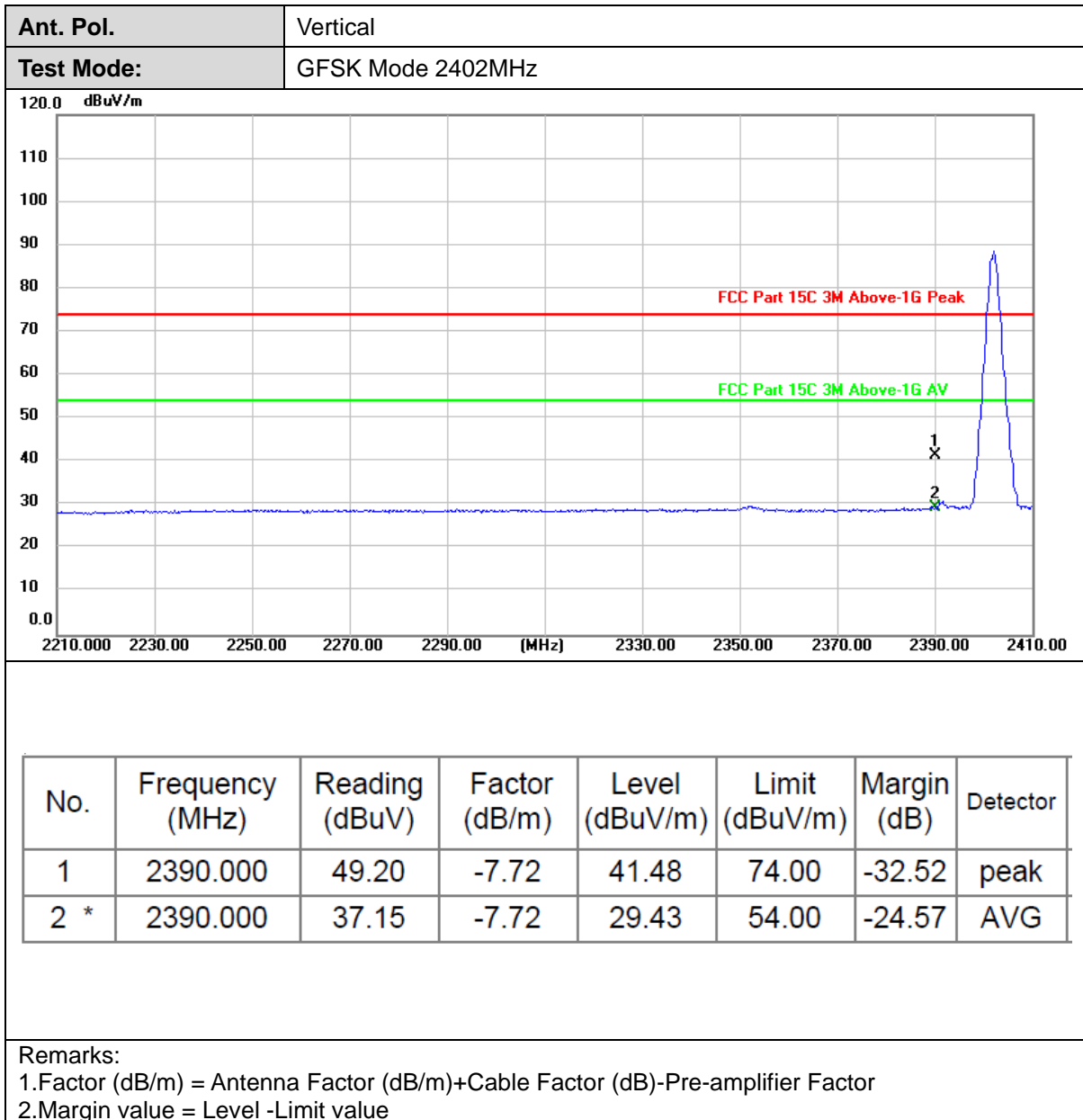



Ant. Pol.	Horizontal
Test Mode:	GFSK Mode 2480MHz

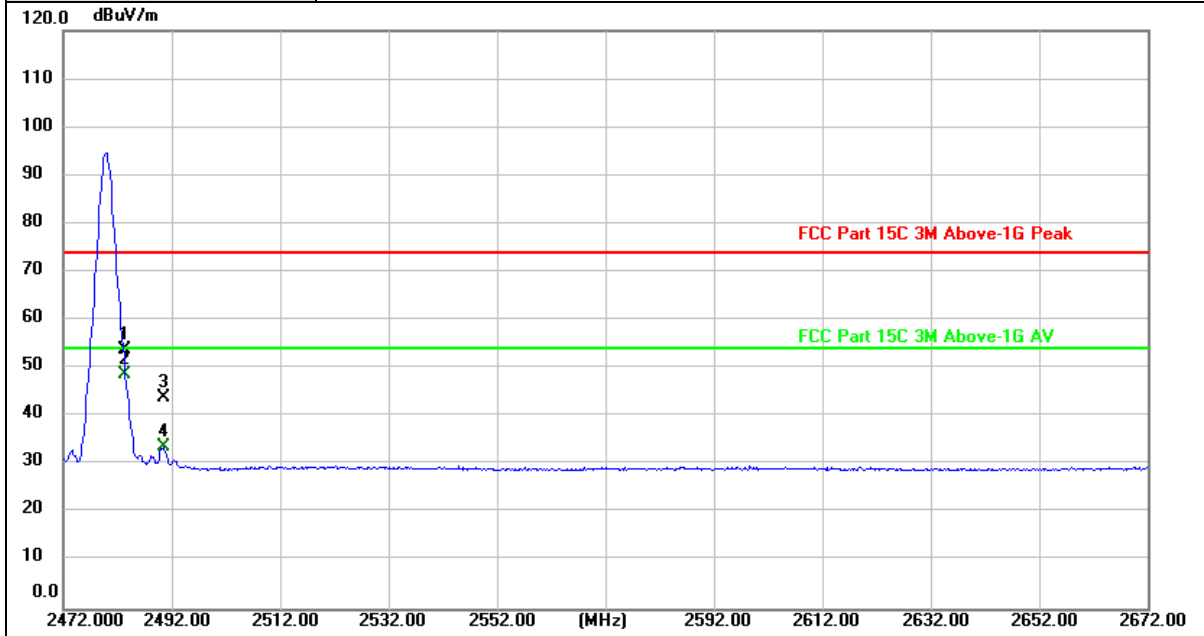

No.	Frequency (MHz)	Reading (dBuV)	Factor (dB/m)	Level (dBuV/m)	Limit (dBuV/m)	Margin (dB)	Detector
1	2483.500	61.19	-7.32	53.87	74.00	-20.13	peak
2 *	2483.500	56.17	-7.32	48.85	54.00	-5.15	AVG
3	2490.560	51.22	-7.29	43.93	74.00	-30.07	peak
4	2490.560	41.11	-7.29	33.82	54.00	-20.18	AVG

Remarks:

- 1. Factor (dB/m) = Antenna Factor (dB/m)+Cable Factor (dB)-Pre-amplifier Factor
- 2. Margin value = Level -Limit value



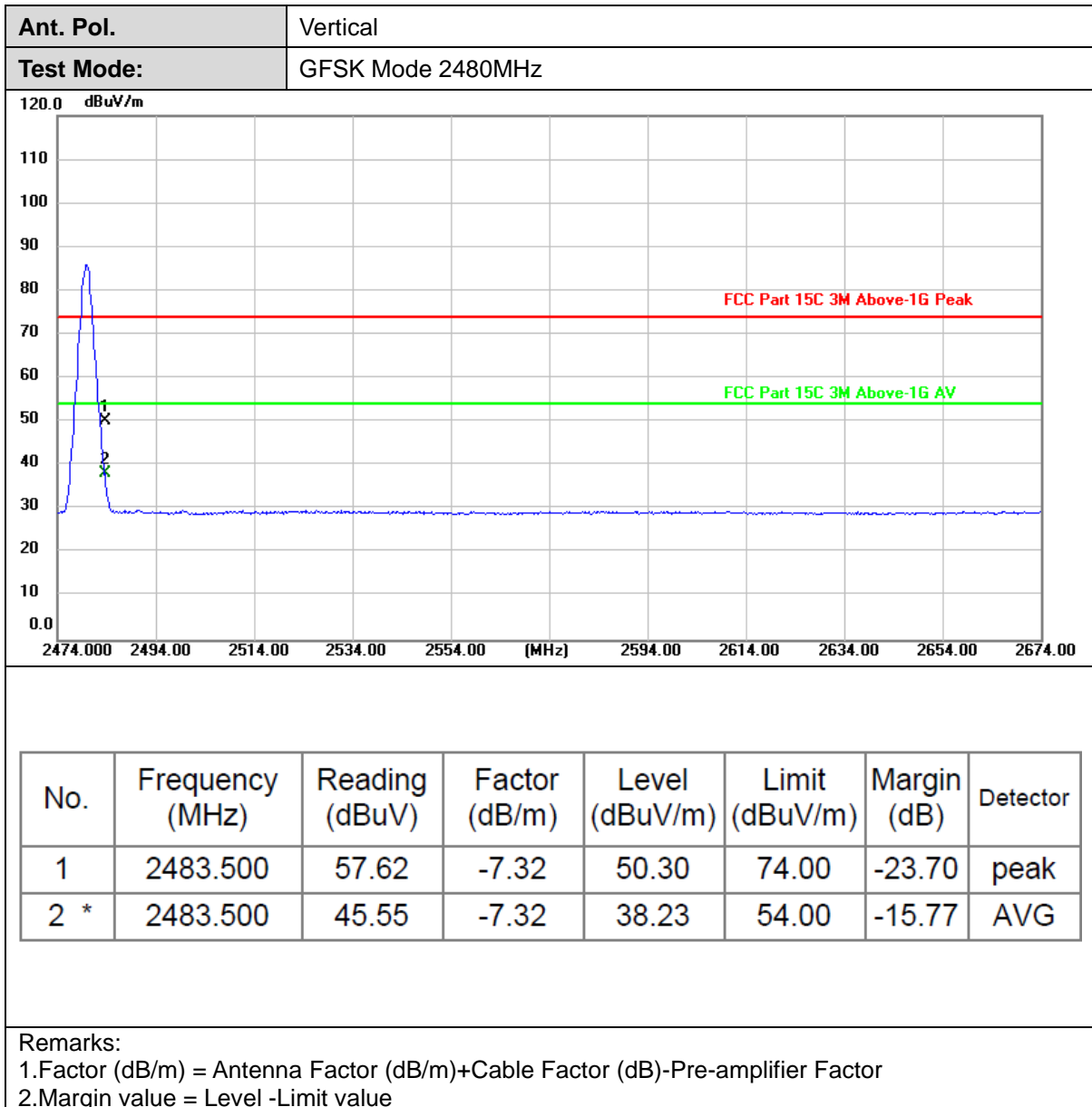



Ant. Pol.	Horizontal
Test Mode:	$\pi/4$ -DQPSK Mode 2402MHz

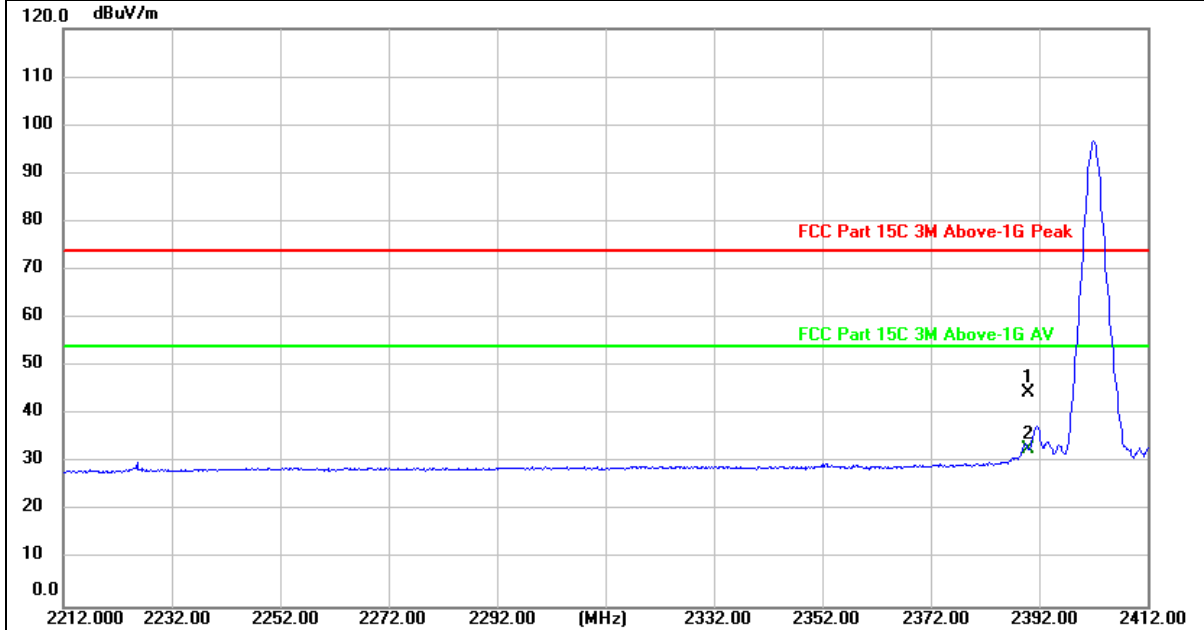

No.	Frequency (MHz)	Reading (dBuV)	Factor (dB/m)	Level (dBuV/m)	Limit (dBuV/m)	Margin (dB)	Detector
1	2390.000	52.25	-7.72	44.53	74.00	-29.47	peak
2 *	2390.000	40.61	-7.72	32.89	54.00	-21.11	AVG

Remarks:

- 1.Factor (dB/m) = Antenna Factor (dB/m)+Cable Factor (dB)-Pre-amplifier Factor
- 2.Margin value = Level -Limit value





Ant. Pol.	Vertical
Test Mode:	$\pi/4$ -DQPSK Mode 2402MHz

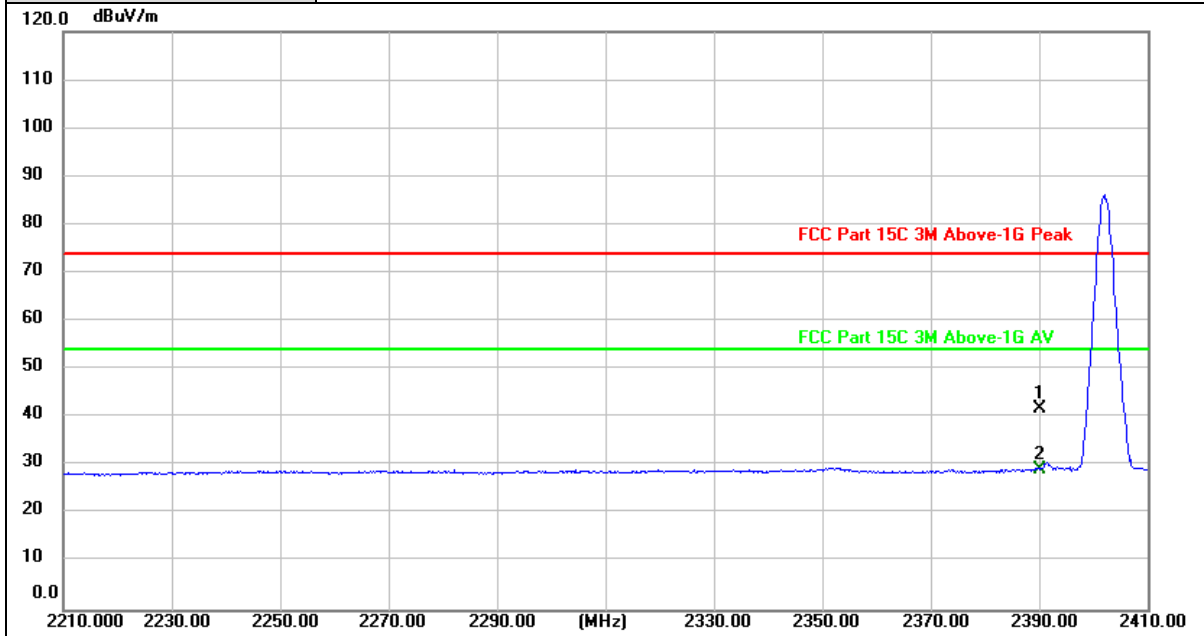

No.	Frequency (MHz)	Reading (dBuV)	Factor (dB/m)	Level (dBuV/m)	Limit (dBuV/m)	Margin (dB)	Detector
1	2390.000	49.59	-7.72	41.87	74.00	-32.13	peak
2 *	2390.000	37.08	-7.72	29.36	54.00	-24.64	AVG

Remarks:

- 1. Factor (dB/m) = Antenna Factor (dB/m)+Cable Factor (dB)-Pre-amplifier Factor
- 2. Margin value = Level -Limit value





Ant. Pol.	Horizontal
Test Mode:	$\pi/4$ -DQPSK Mode 2480MHz

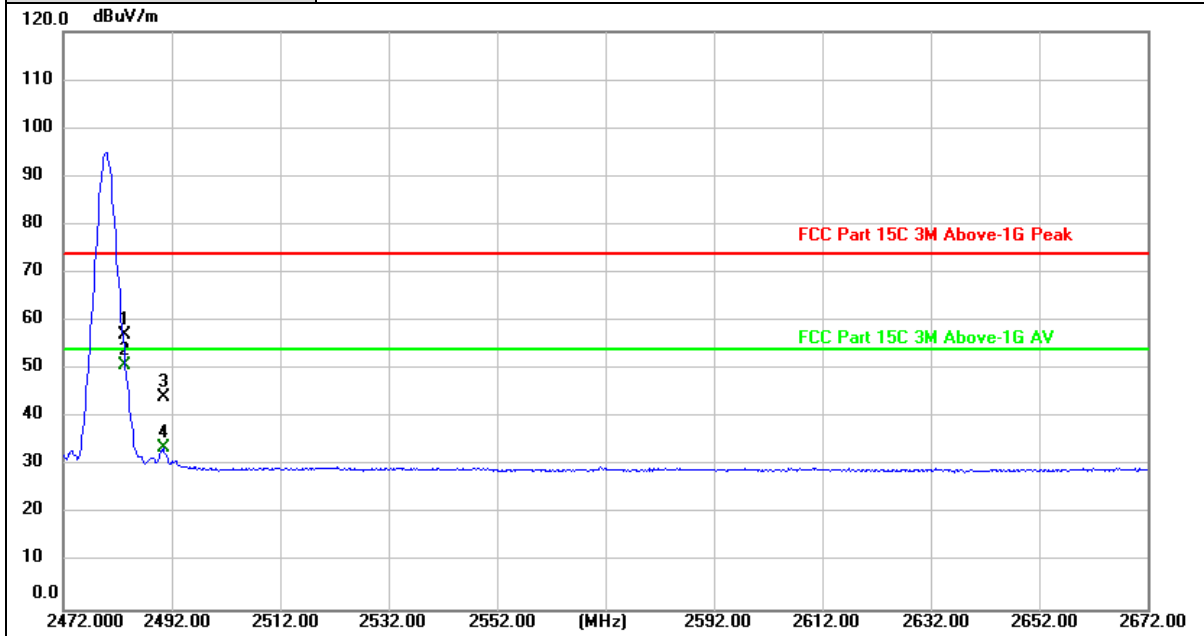

No.	Frequency (MHz)	Reading (dBuV)	Factor (dB/m)	Level (dBuV/m)	Limit (dBuV/m)	Margin (dB)	Detector
1	2483.500	64.57	-7.32	57.25	74.00	-16.75	peak
2 *	2483.500	58.03	-7.32	50.71	54.00	-3.29	AVG
3	2490.400	51.67	-7.29	44.38	74.00	-29.62	peak
4	2490.400	41.08	-7.29	33.79	54.00	-20.21	AVG

Remarks:

- Factor (dB/m) = Antenna Factor (dB/m)+Cable Factor (dB)-Pre-amplifier Factor
- Margin value = Level -Limit value



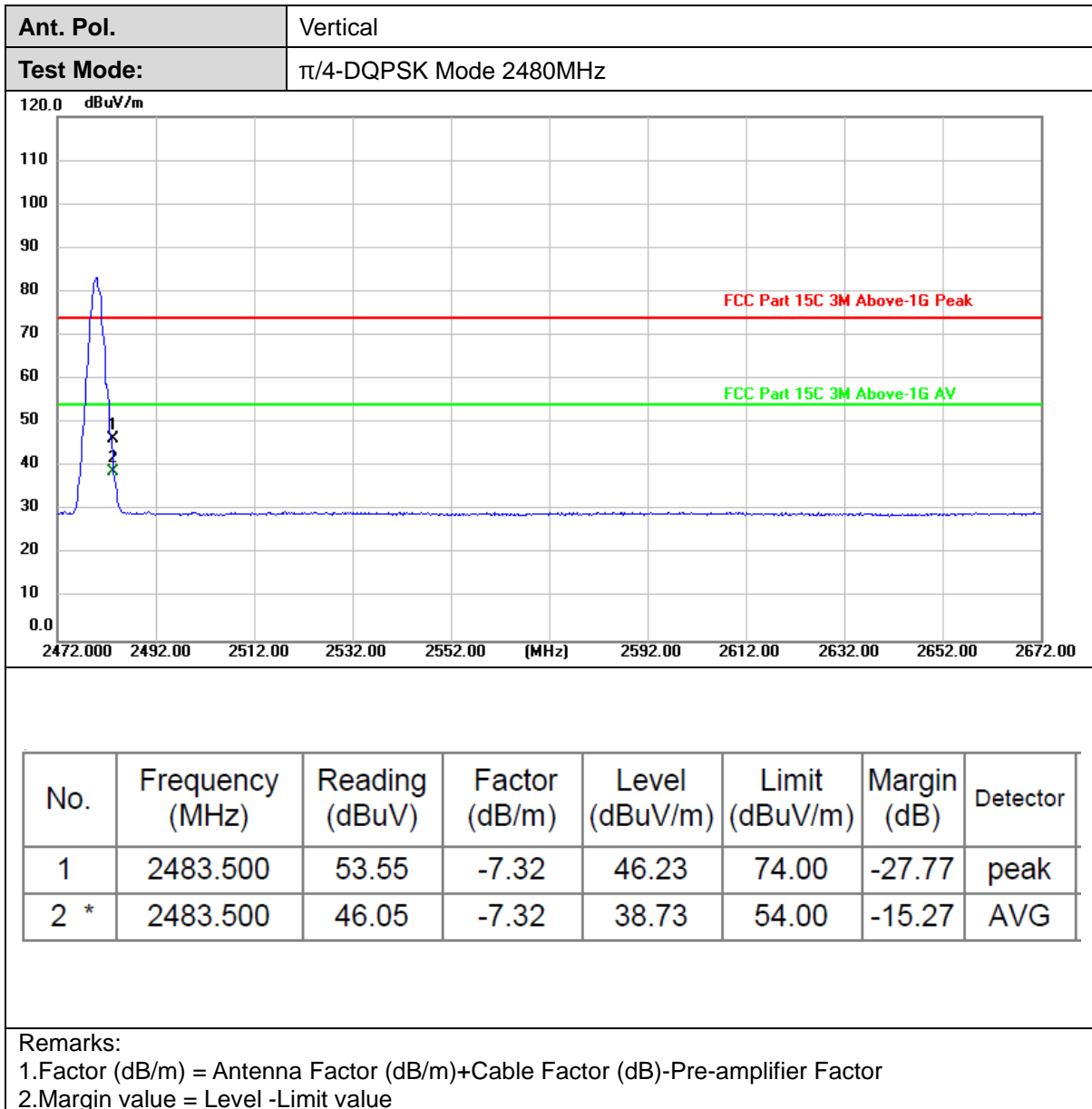



Ant. Pol.	Horizontal
Test Mode:	8-DPSK Mode 2402MHz

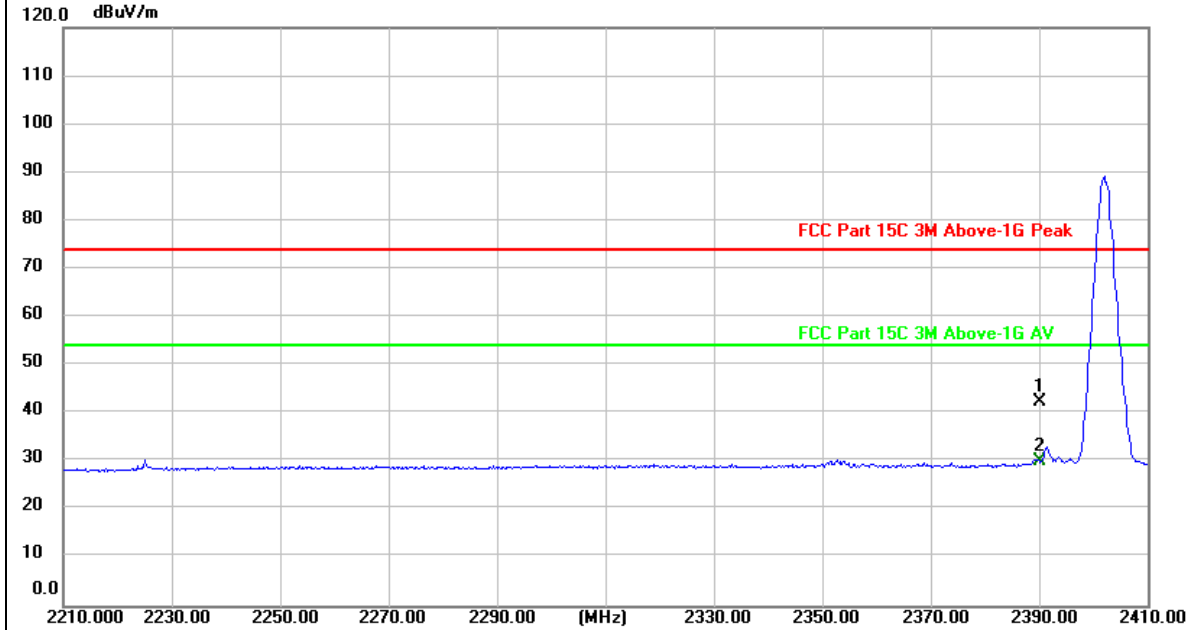

No.	Frequency (MHz)	Reading (dBuV)	Factor (dB/m)	Level (dBuV/m)	Limit (dBuV/m)	Margin (dB)	Detector
1	2390.000	50.22	-7.72	42.50	74.00	-31.50	peak
2 *	2390.000	37.91	-7.72	30.19	54.00	-23.81	AVG

Remarks:

- 1.Factor (dB/m) = Antenna Factor (dB/m)+Cable Factor (dB)-Pre-amplifier Factor
- 2.Margin value = Level -Limit value

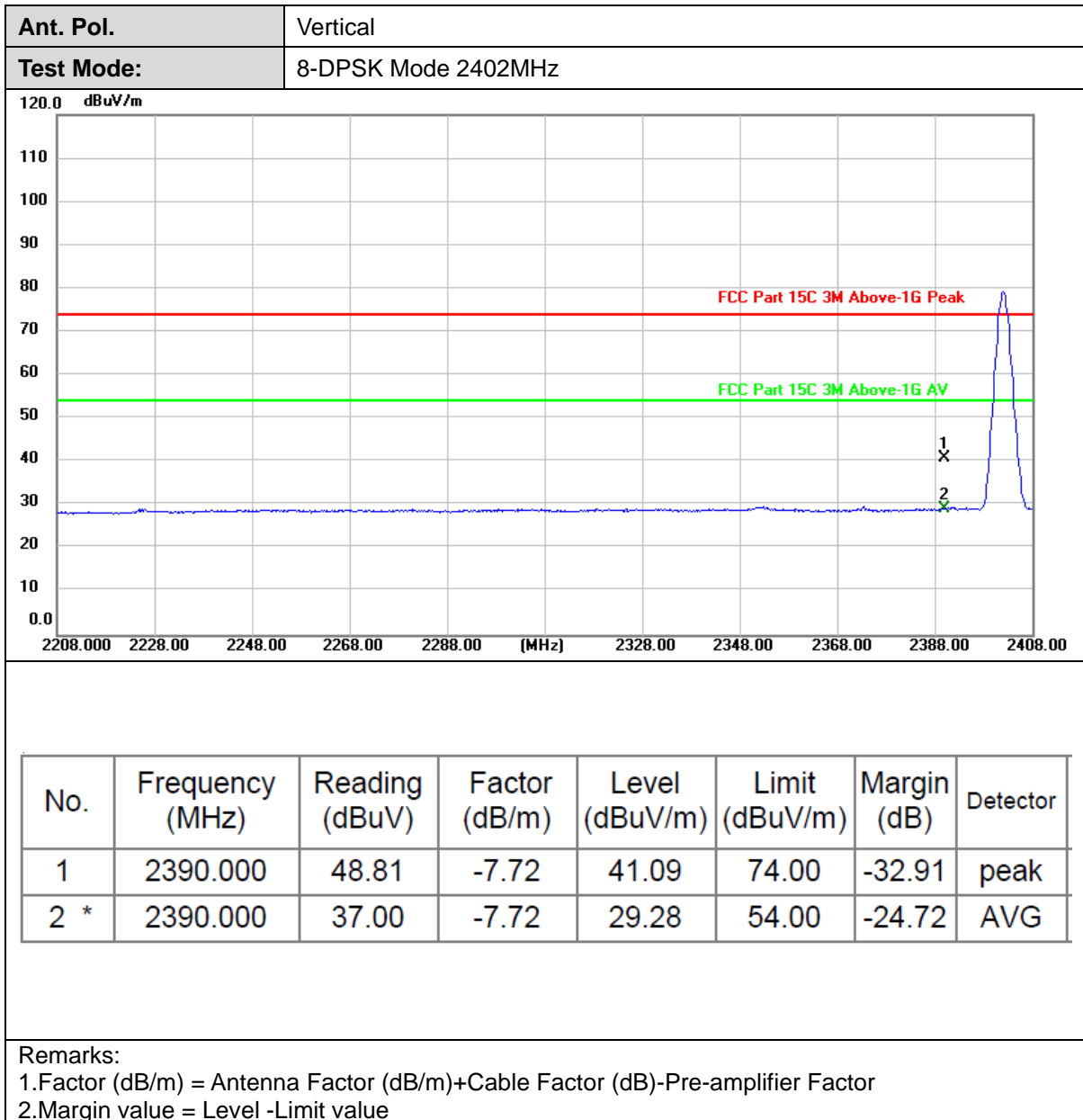



Ant. Pol.	Horizontal
Test Mode:	8-DPSK Mode 2480MHz

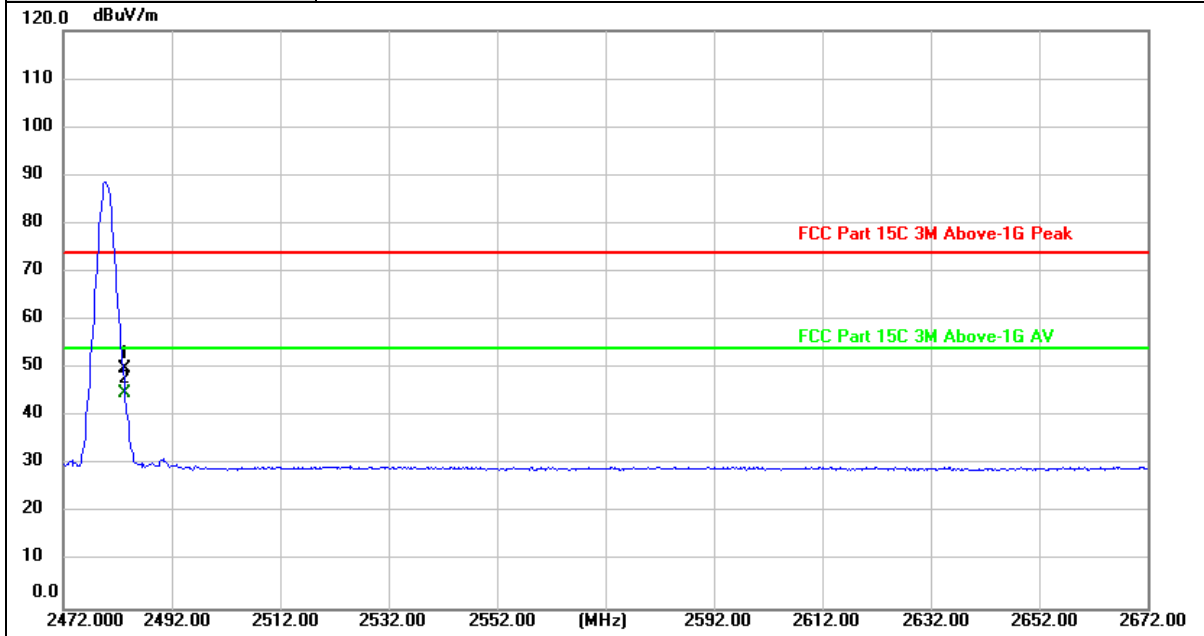

No.	Frequency (MHz)	Reading (dBuV)	Factor (dB/m)	Level (dBuV/m)	Limit (dBuV/m)	Margin (dB)	Detector
1	2483.500	57.36	-7.32	50.04	74.00	-23.96	peak
2 *	2483.500	52.18	-7.32	44.86	54.00	-9.14	AVG

Remarks:

- 1. Factor (dB/m) = Antenna Factor (dB/m)+Cable Factor (dB)-Pre-amplifier Factor
- 2. Margin value = Level -Limit value



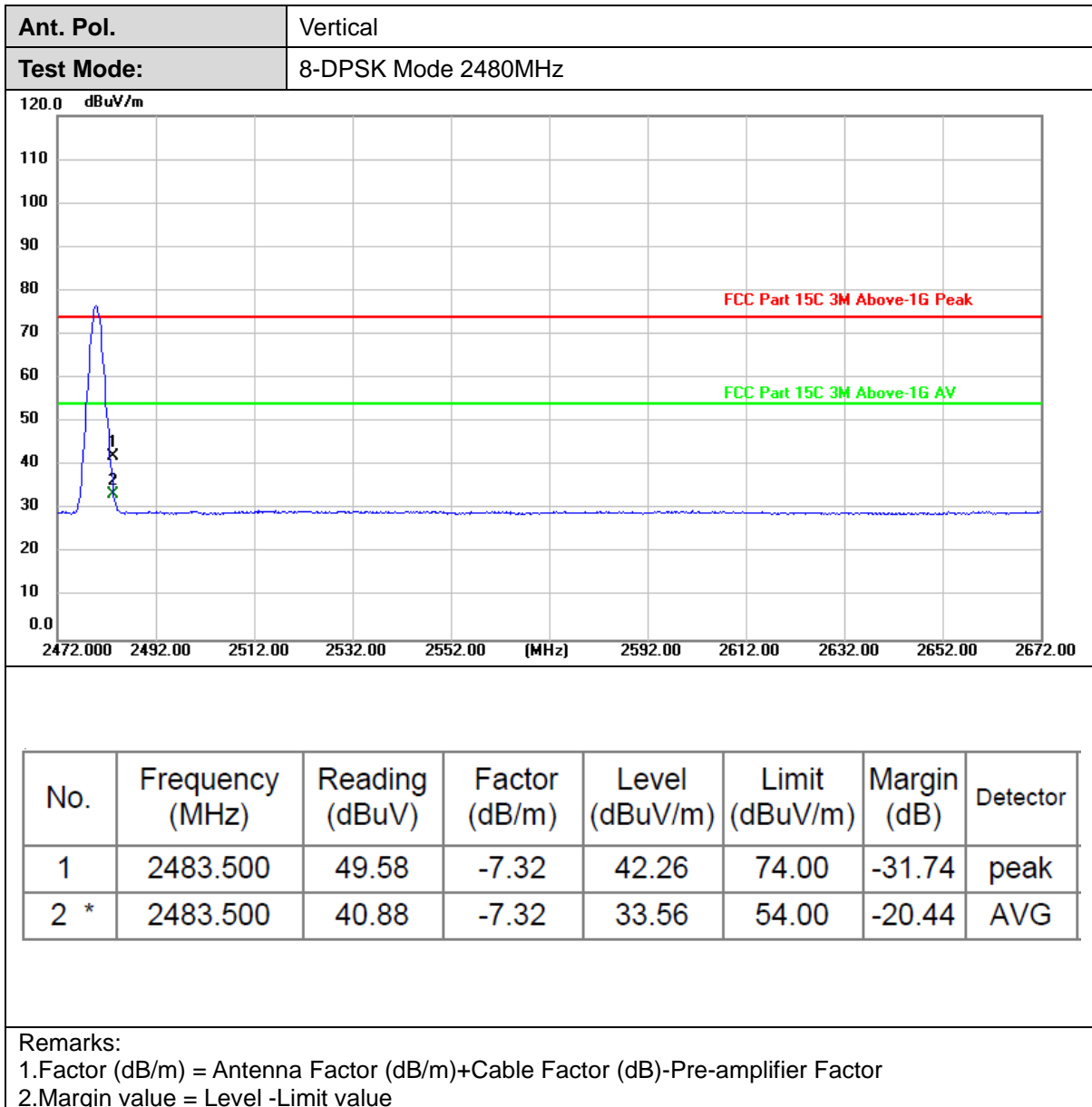



3.4. Band Edge and Spurious Emissions (Conducted)

Limit

FCC CFR Title 47 Part 15 Subpart C Section 15.247 (d)

In any 100 kHz bandwidth outside the frequency band in which the spread spectrum intentional radiator is operating, the radio frequency power that is produced by the intentional radiator shall be at least 20 dB below that in the 100 kHz bandwidth within the band that contains the highest level of the desired power, based on either an RF conducted or a radiated measurement, provided the transmitter demonstrates compliance with the peak conducted power limits. If the transmitter complies with the conducted power limits based on the use of RMS averaging over a time interval, as permitted under paragraph (b)(3) of this section, the attenuation required under this paragraph shall be 30 dB instead of 20 dB.

Test Configuration

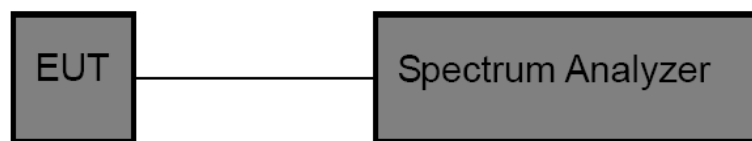

Test Procedure

1. The transmitter output was connected to the spectrum analyzer through an attenuator, the path loss was compensated to the results for each measurement.
2. Set to the maximum power setting and enable the EUT transmit continuously.
3. Use the following spectrum analyzer settings:
RBW = 100 kHz, VBW ≥ RBW, scan up through 10th harmonic.
Sweep = auto, Detector function = peak, Trace = max hold.
4. Measure and record the results in the test report.

Test Mode

Please refer to the clause 2.4.

Test Result

(1) Band Edge Conducted Test

TestMode	Antenna	ChName	Channel	RefLevel [dBm]	Result [dBm]	Limit [dBm]	Verdict
DH5	Ant1	Low	2402	6.79	-49.6	≤-13.21	PASS
		High	2480	7.26	-52.18	≤-12.74	PASS
		Low	Hop_2402	5.72	-56.28	≤-14.28	PASS
		High	Hop_2480	5.92	-58.06	≤-14.08	PASS
2DH5	Ant1	Low	2402	5.51	-49.33	≤-14.49	PASS
		High	2480	7.28	-53.45	≤-12.72	PASS
		Low	Hop_2402	4.81	-58.37	≤-15.19	PASS
		High	Hop_2480	6.24	-58.11	≤-13.76	PASS
3DH5	Ant1	Low	2402	7.42	-48.07	≤-12.58	PASS
		High	2480	7.37	-52.32	≤-12.63	PASS
		Low	Hop_2402	2.98	-57.66	≤-17.02	PASS
		High	Hop_2480	5.99	-58.65	≤-14.01	PASS



Test plot as follows:

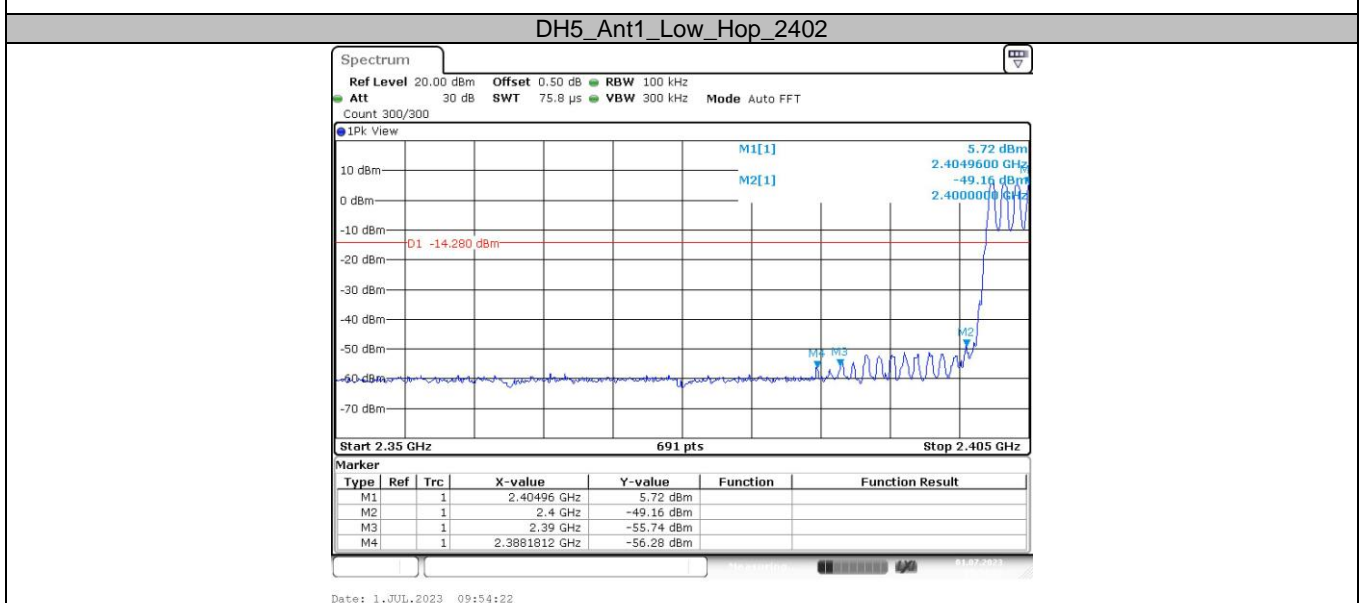
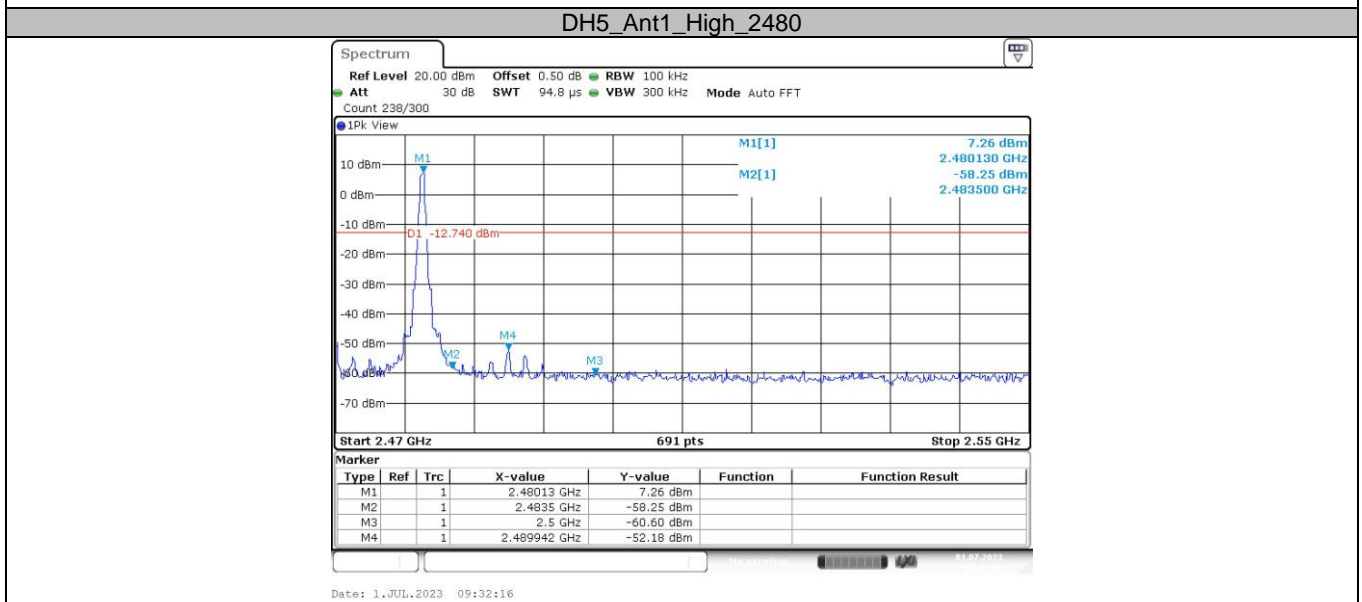
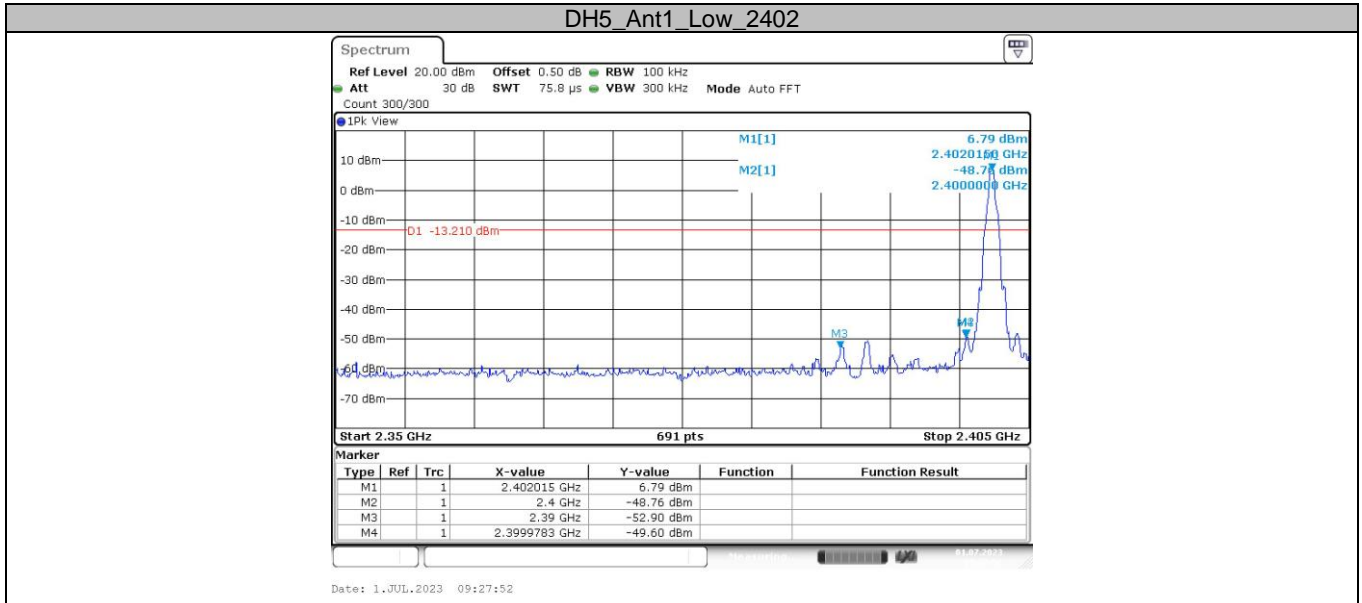

CTC Laboratories, Inc.

2/F., Building 1 and 1-2/F., Building 2, Jiaquan Building, Guanlan High-Tech Park, Longhua District, Shenzhen, Guangdong, China
Tel.: (86)755-27521059 Fax: (86)755-27521011 Http://www.sz-ctc.org.cn



For anti-fake verification, please visit the official website of Certification and Accreditation Administration of the People's Republic of China : <http://yz.cnca.cn>



DH5_Ant1_High_Hop_2480

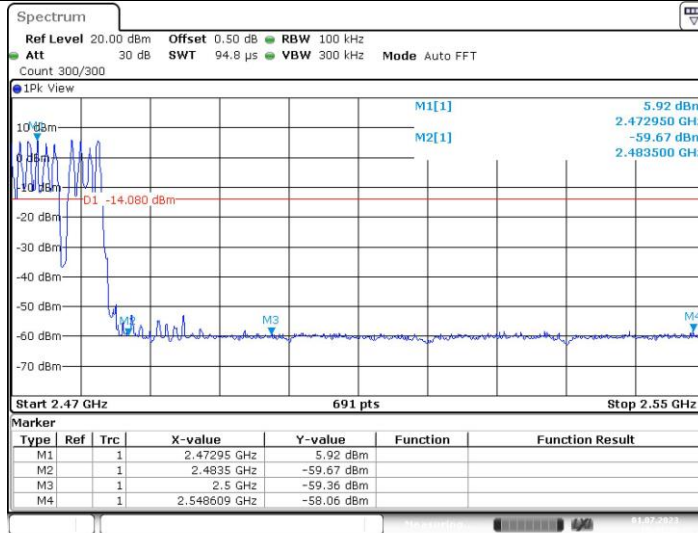

Date: 1.JUL.2023 10:31:39

2DH5_Ant1_Low_2402

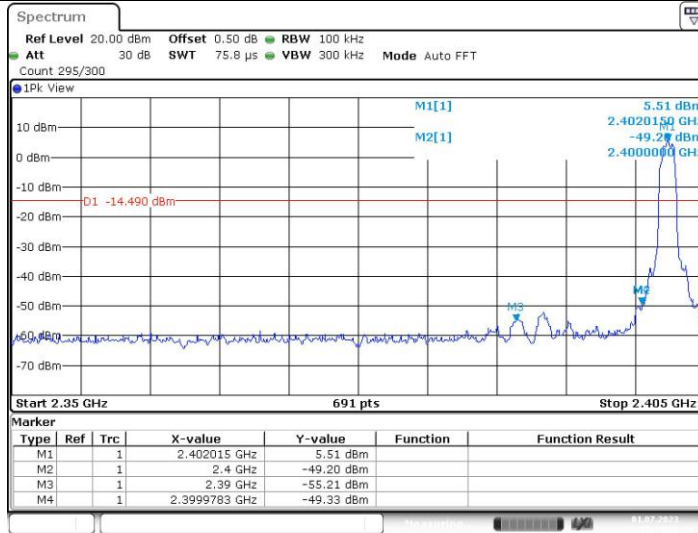

Date: 1.JUL.2023 09:34:21

2DH5_Ant1_High_2480

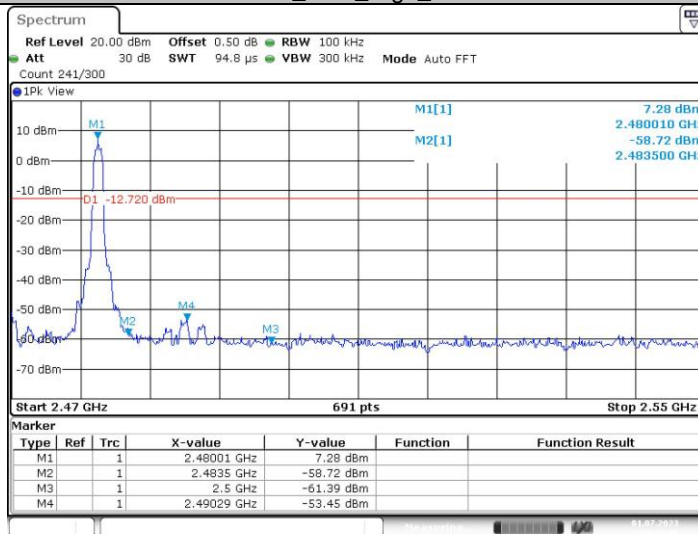

Date: 1.JUL.2023 09:39:46

2DH5_Ant1_Low_Hop_2402



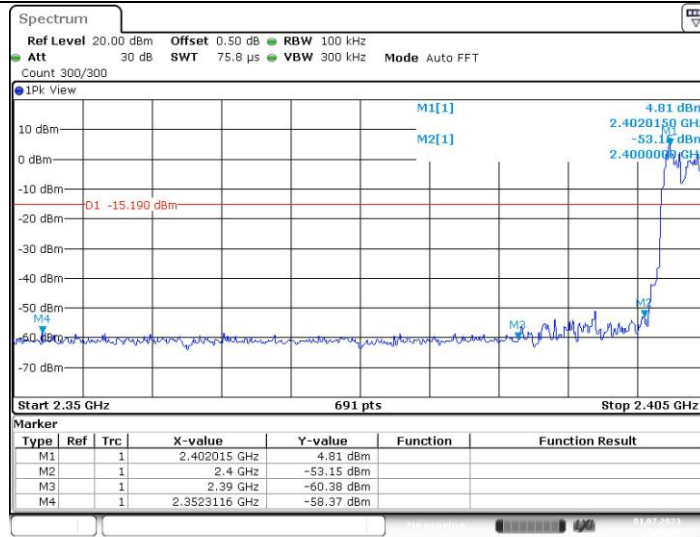

Date: 1.JUL.2023 10:33:54

2DH5_Ant1_High_Hop_2480

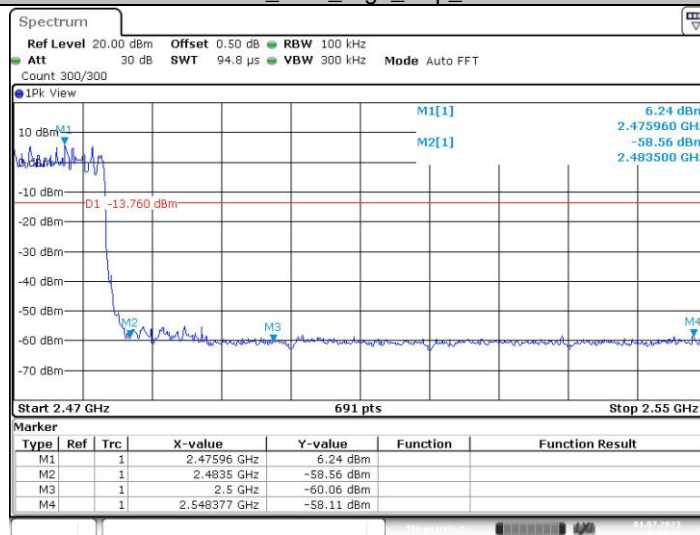

Date: 1.JUL.2023 10:35:18

3DH5_Ant1_Low_2402

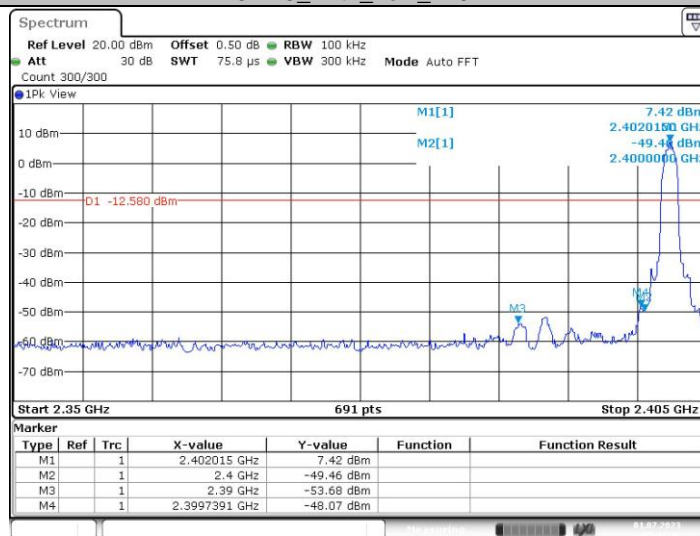

Date: 1.JUL.2023 09:41:32

3DH5_Ant1_High_2480



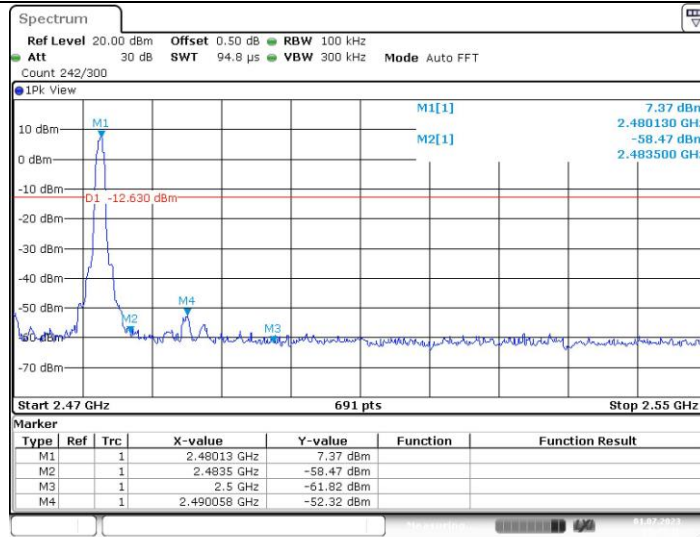

3DH5_Ant1_Low_Hop_2402

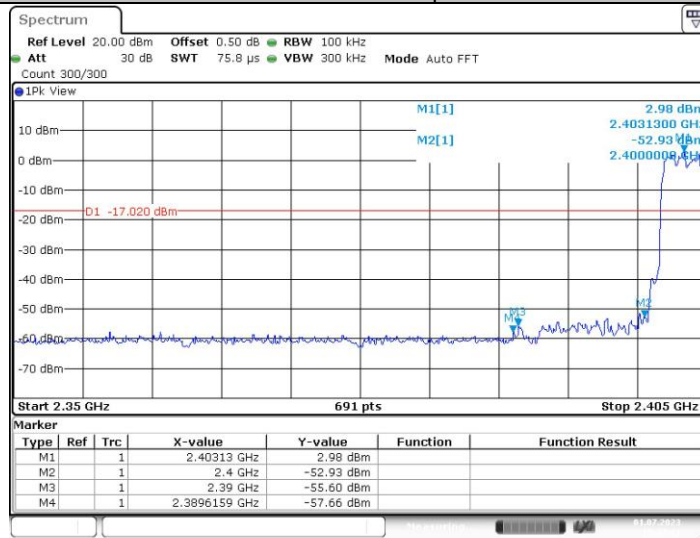

3DH5_Ant1_High_Hop_2480

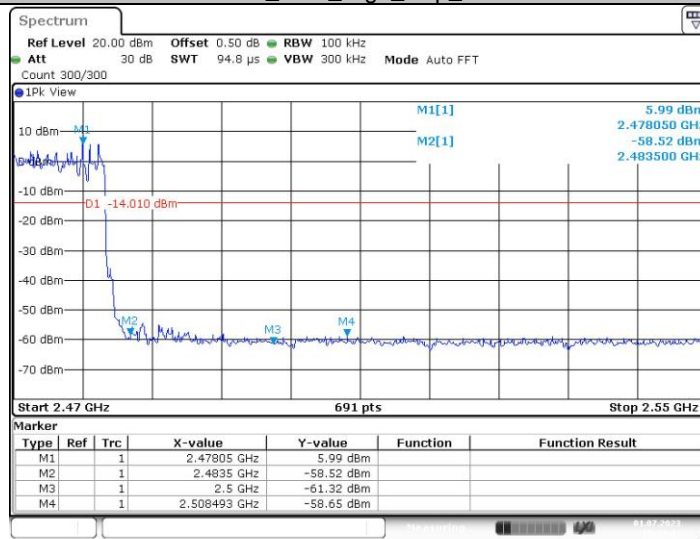



(2) Conducted Spurious Emissions Test

TestMode	Antenna	Channel	FreqRange [MHz]	RefLevel [dBm]	Result [dBm]	Limit [dBm]	Verdict
DH5	Ant1	2402	Reference	6.80	6.80	---	PASS
			30~1000	6.80	-59.12	≤-13.2	PASS
			1000~26500	6.80	-42.52	≤-13.2	PASS
		2441	Reference	7.69	7.69	---	PASS
			30~1000	7.69	-59.47	≤-12.31	PASS
			1000~26500	7.69	-42.63	≤-12.31	PASS
		2480	Reference	7.33	7.33	---	PASS
			30~1000	7.33	-60.09	≤-12.67	PASS
			1000~26500	7.33	-42.43	≤-12.67	PASS
2DH5	Ant1	2402	Reference	7.40	7.40	---	PASS
			30~1000	7.40	-60.53	≤-12.6	PASS
			1000~26500	7.40	-40.7	≤-12.6	PASS
		2441	Reference	7.80	7.80	---	PASS
			30~1000	7.80	-59.79	≤-12.2	PASS
			1000~26500	7.80	-42.15	≤-12.2	PASS
		2480	Reference	7.38	7.38	---	PASS
			30~1000	7.38	-58.91	≤-12.62	PASS
			1000~26500	7.38	-41.27	≤-12.62	PASS
3DH5	Ant1	2402	Reference	7.44	7.44	---	PASS
			30~1000	7.44	-59.64	≤-12.56	PASS
			1000~26500	7.44	-41.79	≤-12.56	PASS
		2441	Reference	7.82	7.82	---	PASS
			30~1000	7.82	-60.43	≤-12.18	PASS
			1000~26500	7.82	-41.45	≤-12.18	PASS
		2480	Reference	7.38	7.38	---	PASS
			30~1000	7.38	-60.58	≤-12.62	PASS
			1000~26500	7.38	-42.1	≤-12.62	PASS



Test plot as follows:

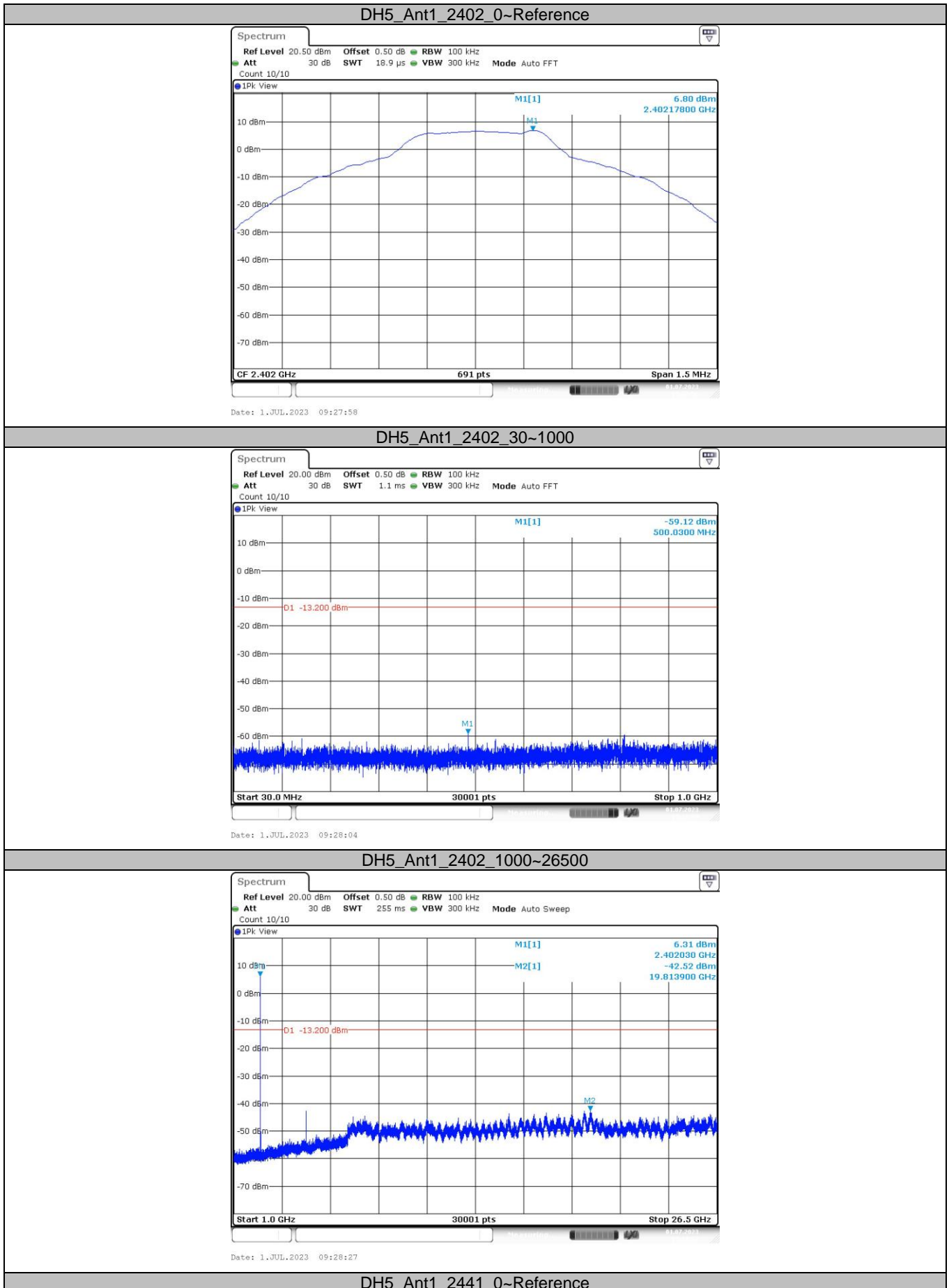

CTC Laboratories, Inc.

2/F., Building 1 and 1-2/F., Building 2, Jiaquan Building, Guanlan High-Tech Park, Longhua District, Shenzhen, Guangdong, China
 Tel.: (86)755-27521059 Fax: (86)755-27521011 Http://www.sz-ctc.org.cn



For anti-fake verification, please visit the official website of Certification and Accreditation Administration of the People's Republic of China : <http://yz.cnca.cn>



Date: 1 JUL 2023 09:29:46

DH5_Ant1_2441_30~1000

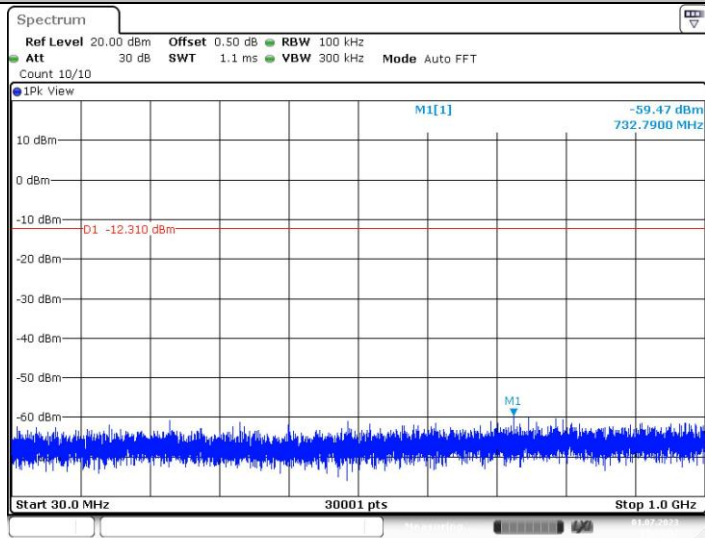

Date: 1 JUL 2023 09:29:51

DH5_Ant1_2441_1000~26500

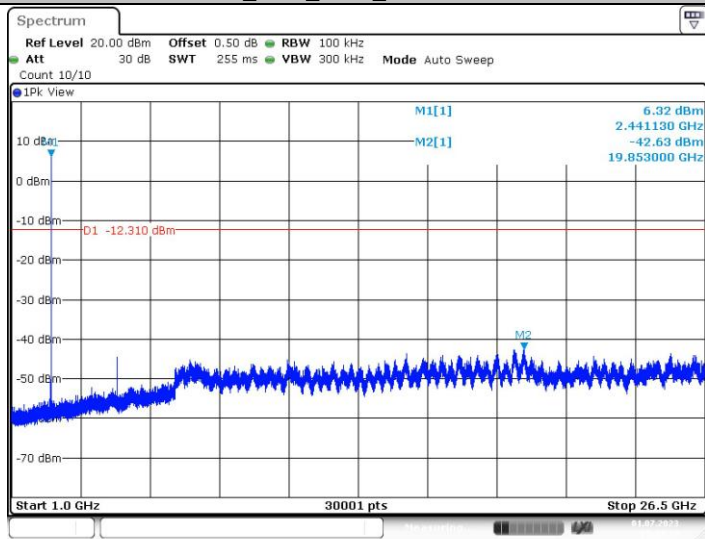

Date: 1 JUL 2023 09:30:14

DH5_Ant1_2480_0~Reference

CTC Laboratories, Inc.

2/F., Building 1 and 1-2/F., Building 2, Jiaquan Building, Guanlan High-Tech Park, Longhua District, Shenzhen, Guangdong, China
 Tel.: (86)755-27521059 Fax: (86)755-27521011 Http://www.sz-ctc.org.cn



For anti-fake verification, please visit the official website of Certification and Accreditation Administration of the People's Republic of China : <http://yz.cnca.cn>



Date: 1 JUL 2023 09:32:23

DH5_Ant1_2480_30~1000

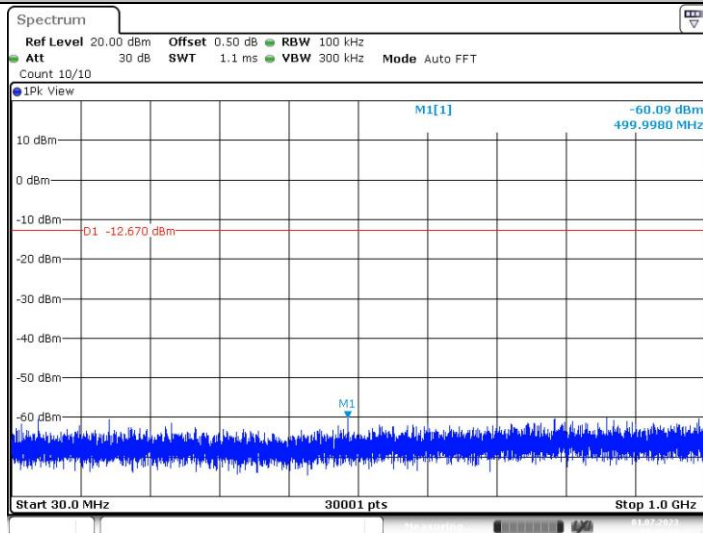

Date: 1 JUL 2023 09:32:28

DH5_Ant1_2480_1000~26500

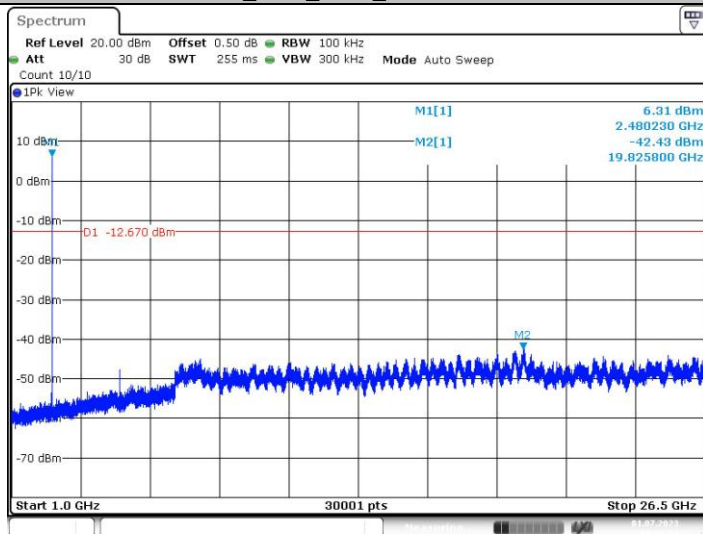

Date: 1 JUL 2023 09:32:52

2DH5_Ant1_2402_0~Reference



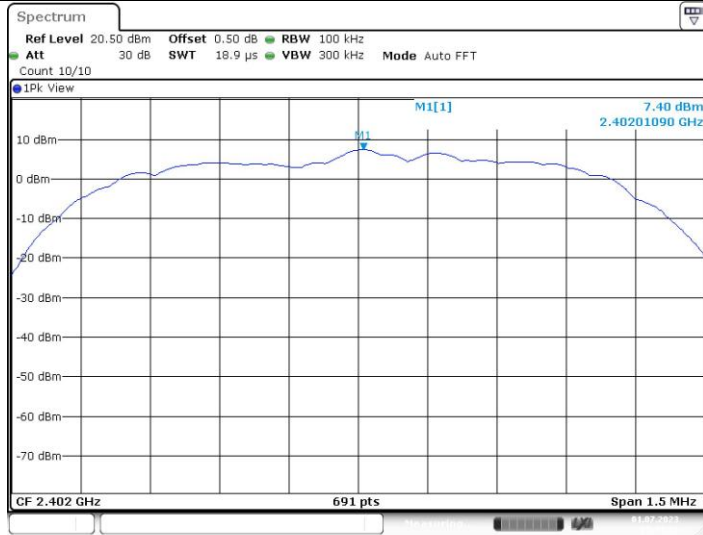

Date: 1 JUL 2023 09:34:28

2DH5_Ant1_2402_30~1000

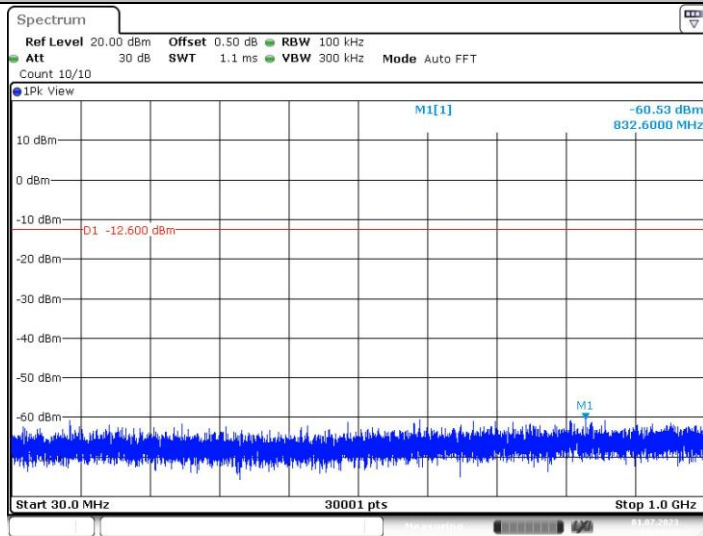

Date: 1 JUL 2023 09:34:33

2DH5_Ant1_2402_1000~26500

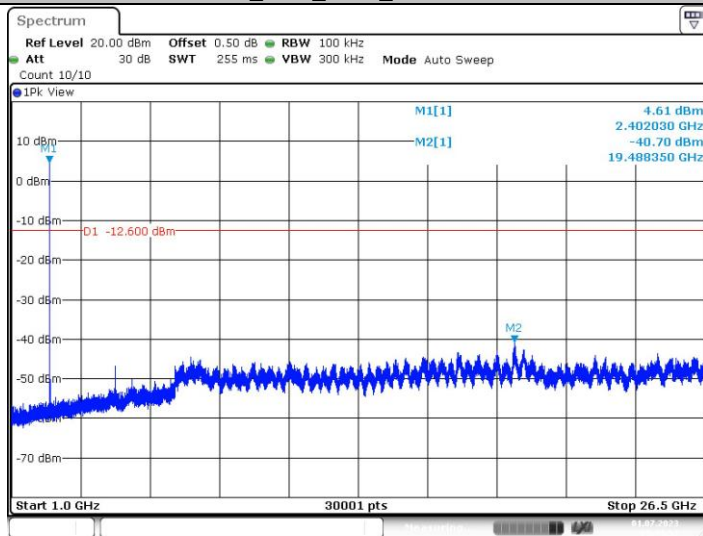

Date: 1 JUL 2023 09:34:56

2DH5_Ant1_2441_0~Reference

CTC Laboratories, Inc.

2/F., Building 1 and 1-2/F., Building 2, Jiaquan Building, Guanlan High-Tech Park, Longhua District, Shenzhen, Guangdong, China
 Tel.: (86)755-27521059 Fax: (86)755-27521011 Http://www.sz-ctc.org.cn



For anti-fake verification, please visit the official website of Certification and Accreditation Administration of the People's Republic of China : <http://yz.cnca.cn>

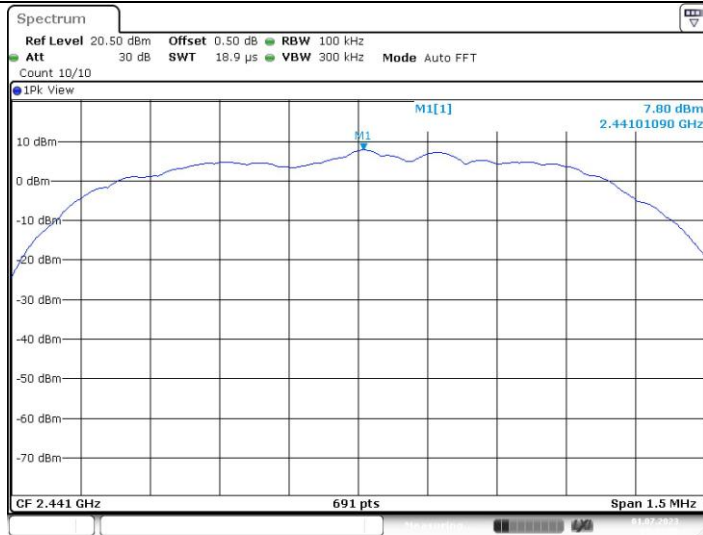

Date: 1.JUL.2023 09:36:05

2DH5_Ant1_2441_30~1000

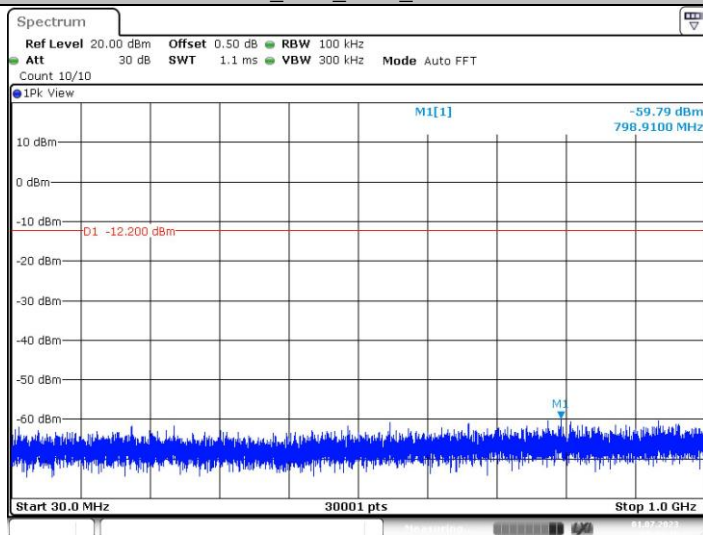

Date: 1.JUL.2023 09:36:10

2DH5_Ant1_2441_1000~26500

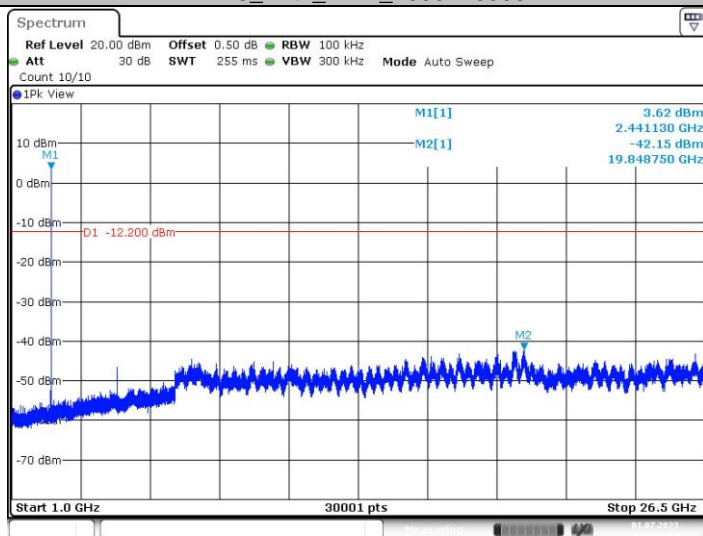

Date: 1.JUL.2023 09:36:33

2DH5_Ant1_2480_0~Reference

CTC Laboratories, Inc.

2/F., Building 1 and 1-2/F., Building 2, Jiaquan Building, Guanlan High-Tech Park, Longhua District, Shenzhen, Guangdong, China
 Tel.: (86)755-27521059 Fax: (86)755-27521011 Http://www.sz-ctc.org.cn



For anti-fake verification, please visit the official website of Certification and Accreditation Administration of the People's Republic of China : <http://yz.cnca.cn>

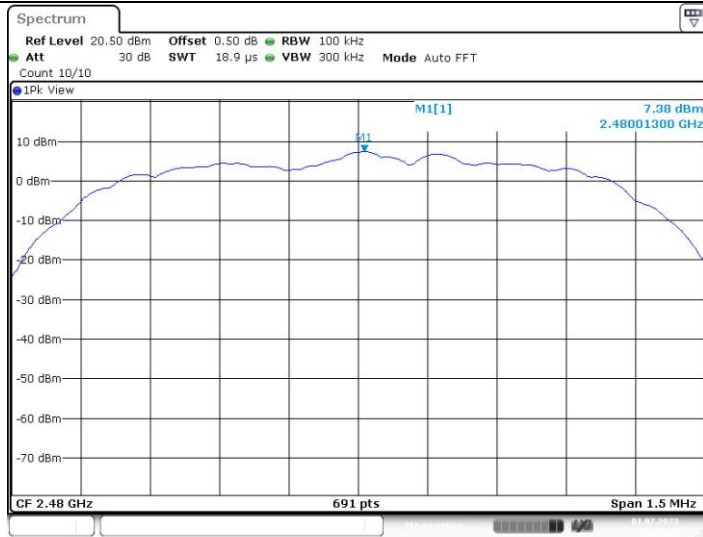

Date: 1.JUL.2023 09:39:53

2DH5_Ant1_2480_30~1000

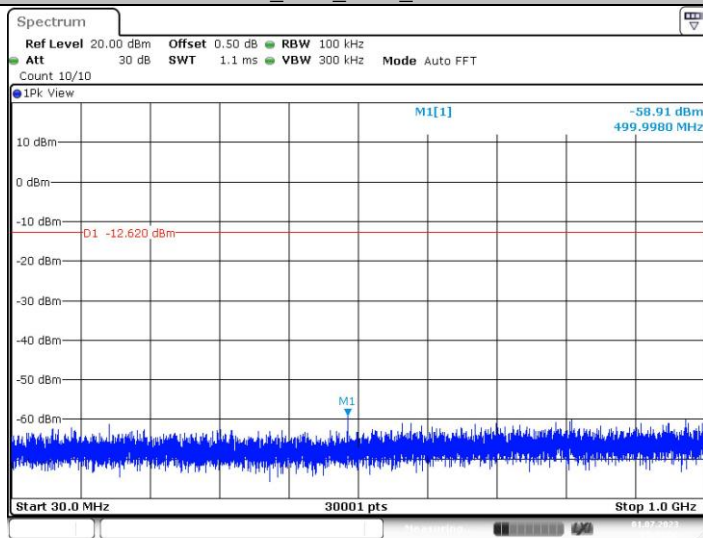

Date: 1.JUL.2023 09:39:58

2DH5_Ant1_2480_1000~26500

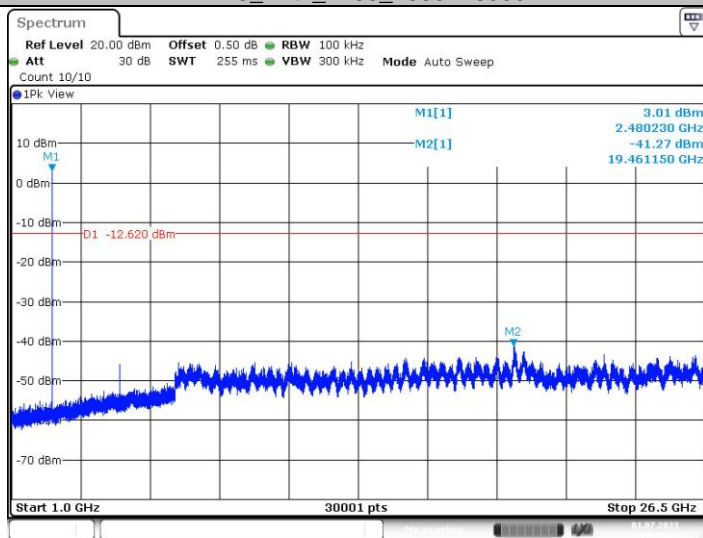

Date: 1.JUL.2023 09:40:21

3DH5_Ant1_2402_0~Reference



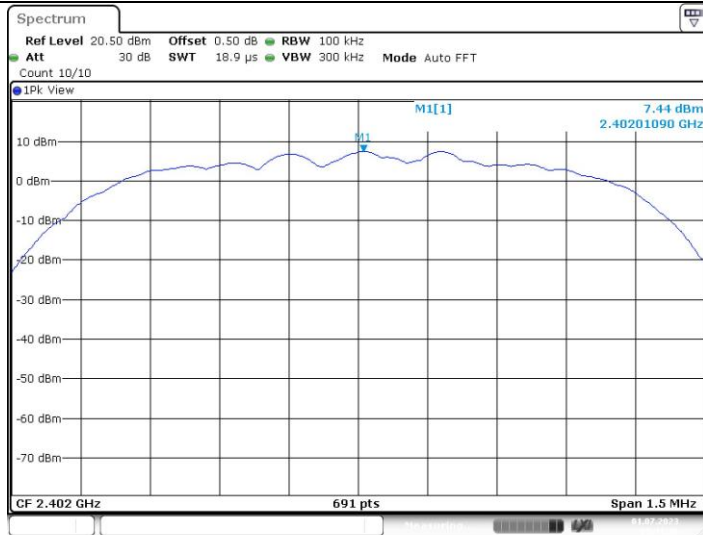

3DH5_Ant1_2402_30~1000

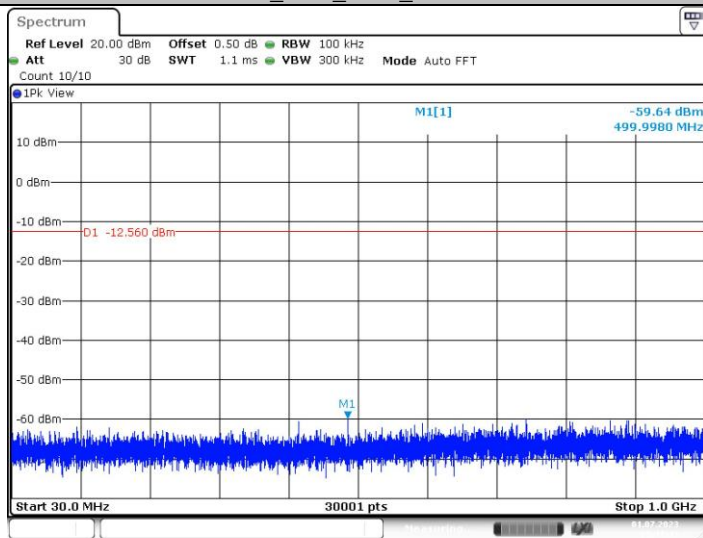

3DH5_Ant1_2402_1000~26500

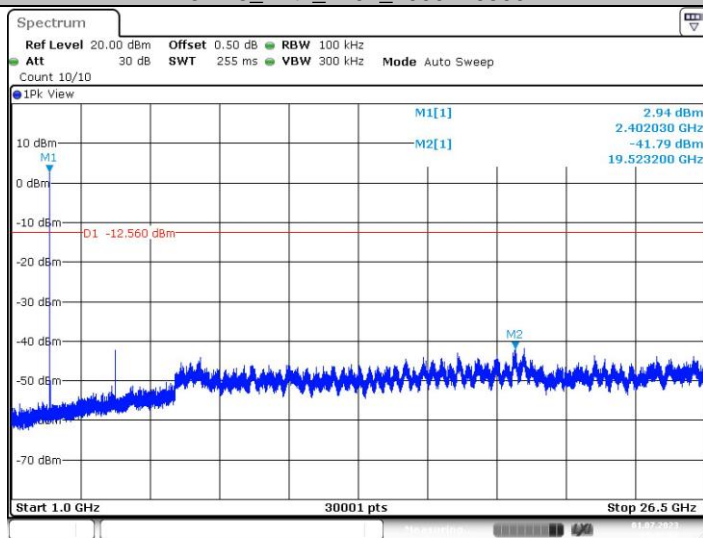

3DH5_Ant1_2441_0~Reference

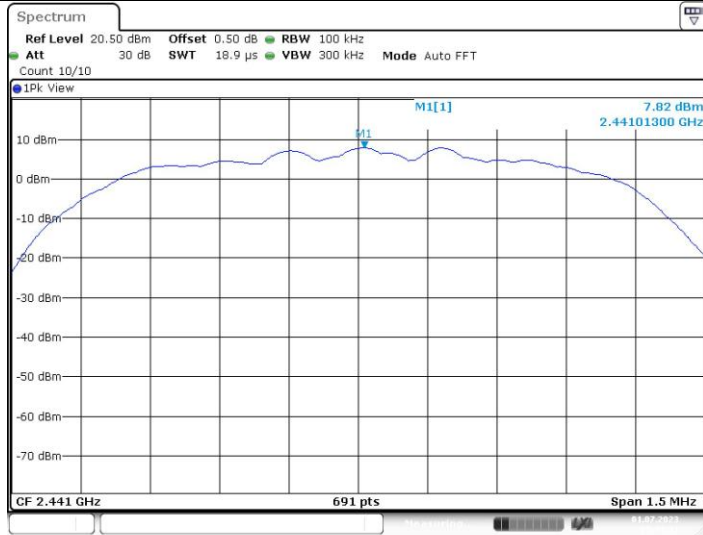

Date: 1 JUL 2023 09:43:32

3DH5_Ant1_2441_30~1000

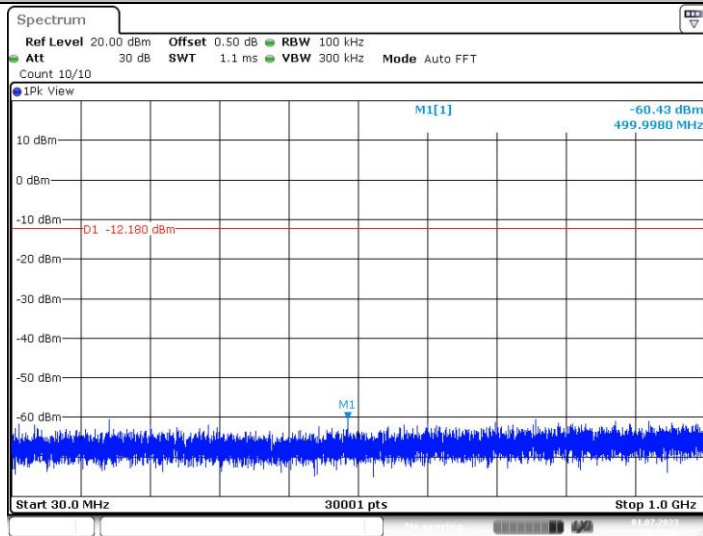

Date: 1 JUL 2023 09:43:37

3DH5_Ant1_2441_1000~26500

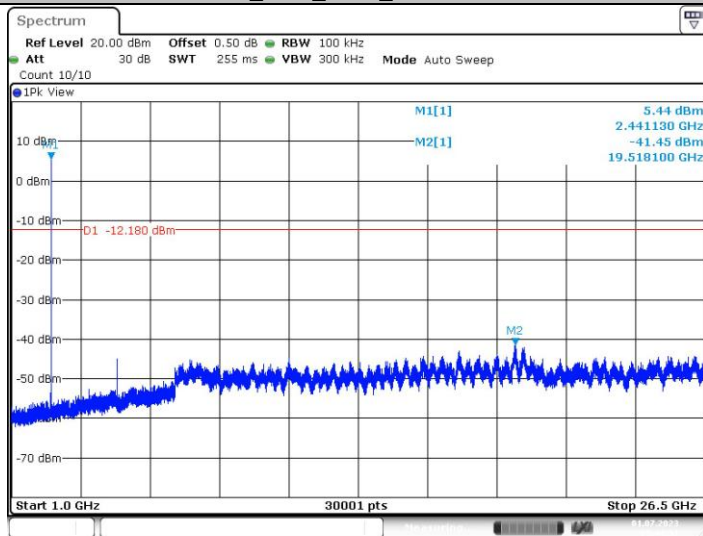

Date: 1 JUL 2023 09:44:00

3DH5_Ant1_2480_0~Reference

CTC Laboratories, Inc.

2/F., Building 1 and 1-2/F., Building 2, Jiaquan Building, Guanlan High-Tech Park, Longhua District, Shenzhen, Guangdong, China
 Tel.: (86)755-27521059 Fax: (86)755-27521011 Http://www.sz-ctc.org.cn



For anti-fake verification, please visit the official website of Certification and Accreditation Administration of the People's Republic of China : <http://yz.cnca.cn>

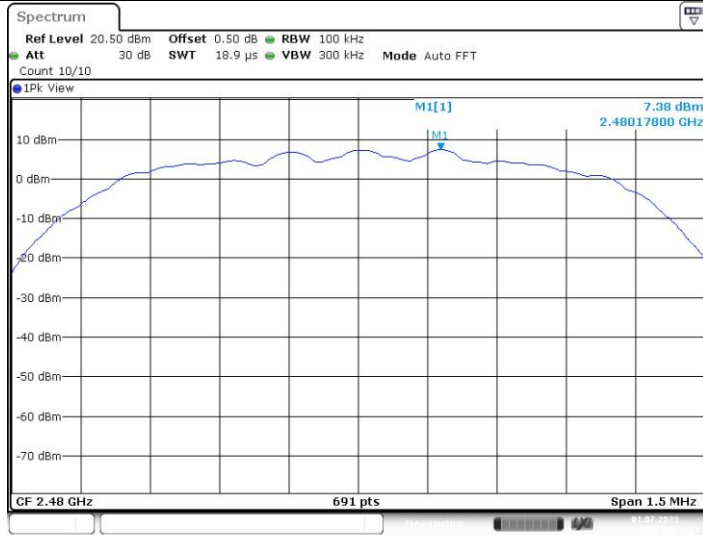

Date: 1 JUL 2023 09:45:22

3DH5_Ant1_2480_30~1000

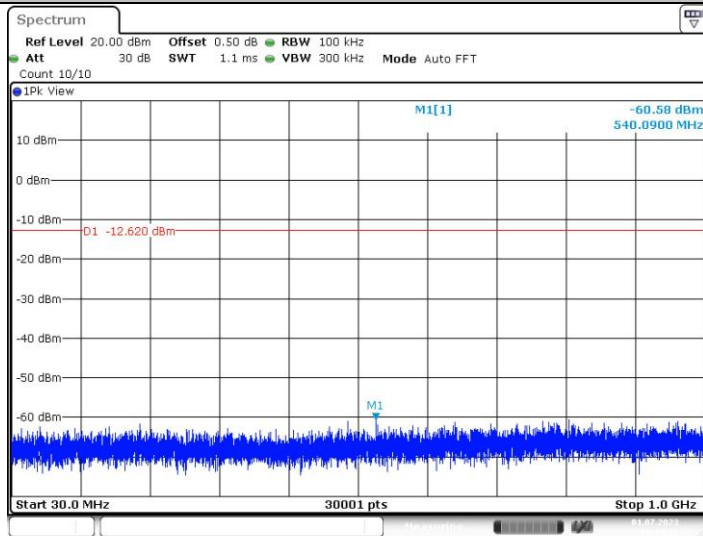

Date: 1 JUL 2023 09:45:27

3DH5_Ant1_2480_1000~26500

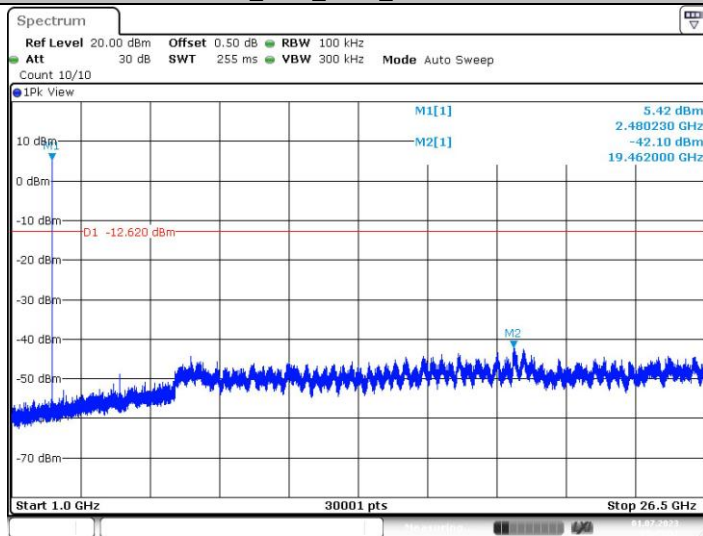

Date: 1 JUL 2023 09:45:50





3.5. 20dB Bandwidth

Limit

N/A

Test Configuration

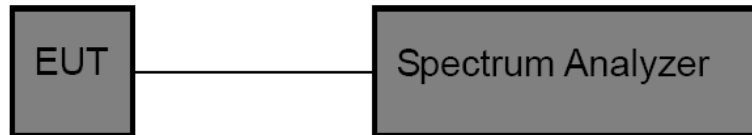

Test Procedure

1. The EUT was directly connected to the spectrum analyzer and antenna output port as show in the block diagram above.
2. OCB and 20dB Spectrum Setting:
 - (1) Set RBW = 1% ~ 5% occupied bandwidth.
 - (2) Set the video bandwidth (VBW) ≥ 3 RBW.
 - (3) Detector = Peak.
 - (4) Trace mode = Max hold.
 - (5) Sweep = Auto couple.

Note: The EUT was set to continuously transmitting in each mode and low, Middle and high channel for the test.

Test Mode

Please refer to the clause 2.4.

Test Result

Test Mode	Frequency (MHz)	99% Bandwidth (MHz)	20dB Bandwidth (MHz)	20dB Bandwidth *2/3 (MHz)
GFSK	2402	0.899	0.99	0.66
	2441	0.899	0.99	0.66
	2480	0.899	0.99	0.66
$\pi/4$ -DQPSK	2402	1.181	1.29	0.86
	2441	1.181	1.29	0.86
	2480	1.181	1.29	0.86
8-DPSK	2402	1.169	1.30	0.87
	2441	1.169	1.29	0.86
	2480	1.172	1.29	0.86



99% Bandwidth:

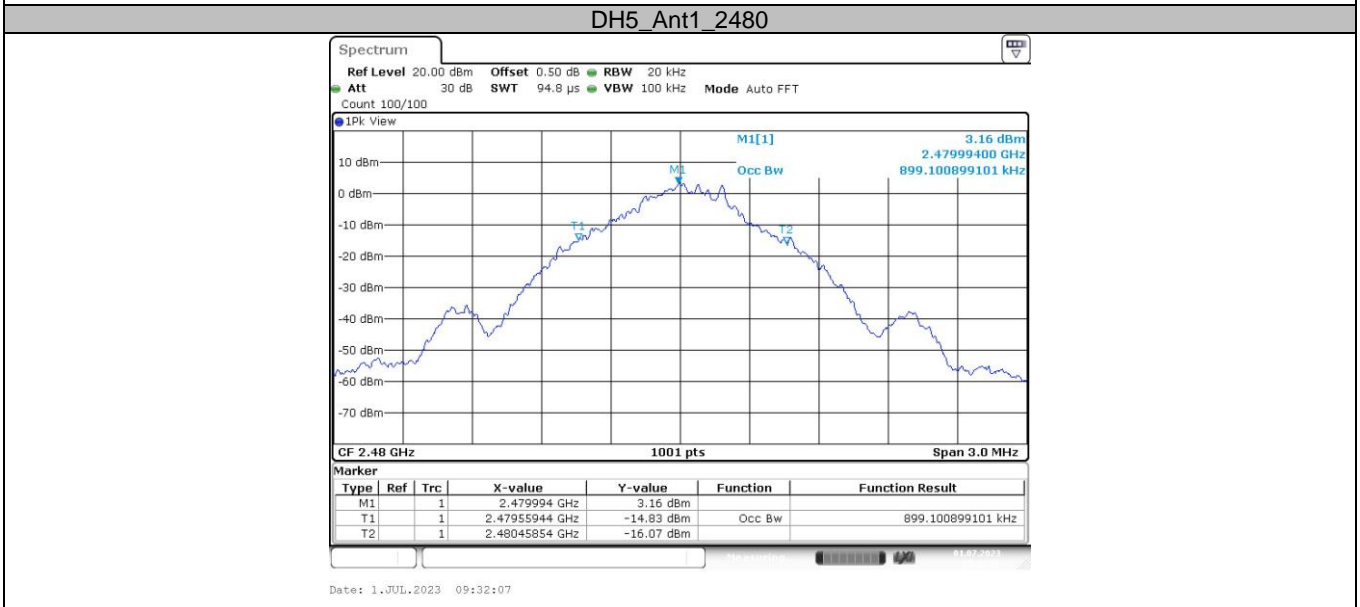
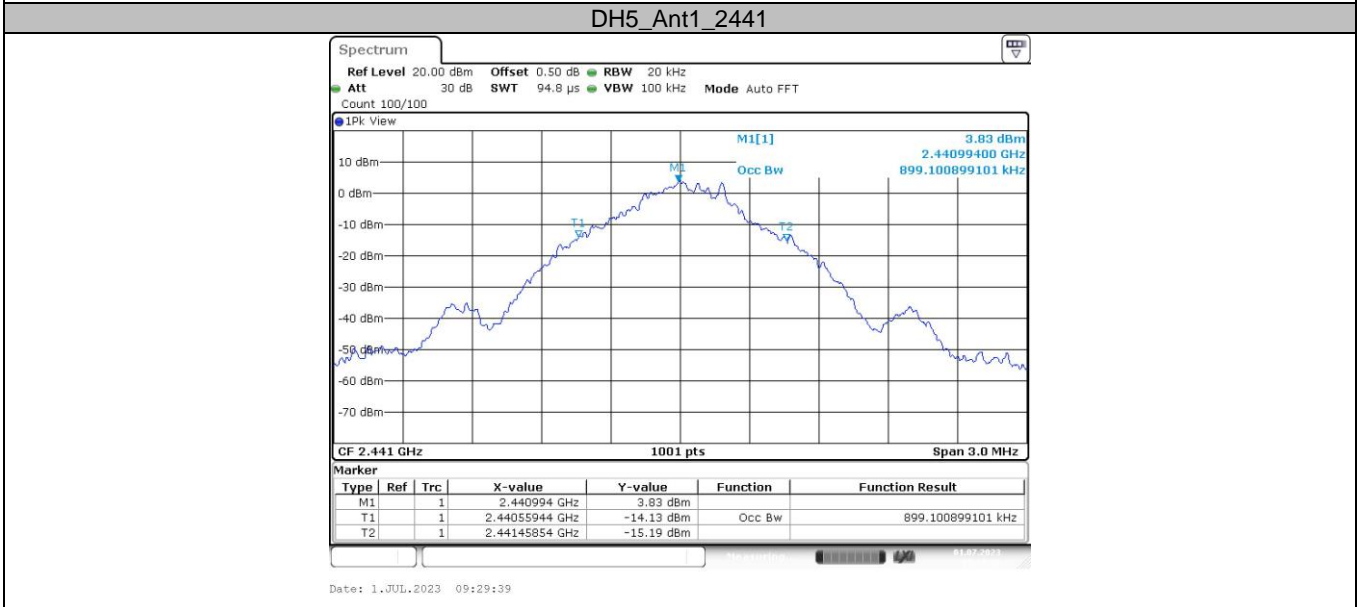
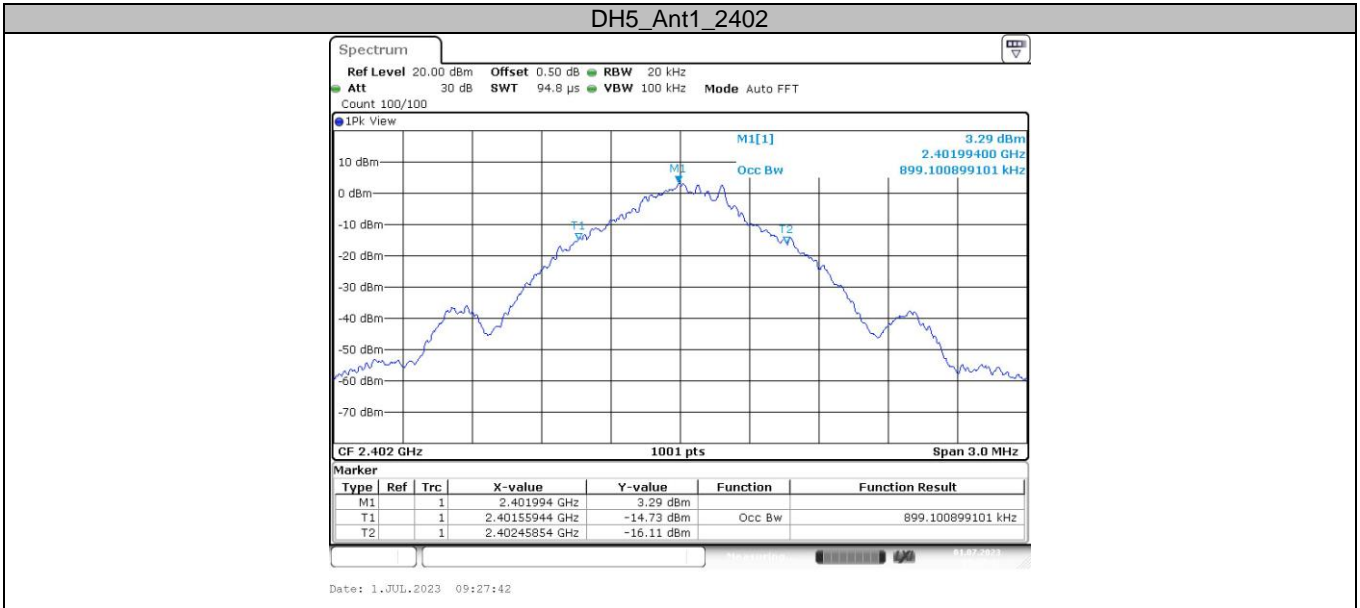

2DH5_Ant1_2402

