



# FCC 47 CFR PART 15 SUBPART C

## TEST REPORT

*For*

**Applicant :** Shenzhen Skyworth Digital Technology Co., LTD.

**Address :** Unit A14/F.Skyworth Building.,Gaoxin Ave.1s.,Nanshan District,  
Shenzhen,China

**Product Name :** Full HD Cludio TV Set-Top Box

**Model Name :** HPM5, A6

**Brand Name :** SKYWORTH

**FCC ID :** WNA-A6

**Report No. :** MTE/DAL/T13091303

**Date of Issue :** Sep. 26, 2013

**Issued by :** Most Technology Service Co., Ltd.

**Address :** No.5, Langshan 2nd Rd., North Hi-Tech Industrial park, Nanshan,  
Shenzhen, Guangdong, China

**Tel :** 86-755-8617 0306

**Fax :** 86-755-8617 0310

*The report consists 78 pages in total. It may be duplicated completely for legal use with the approval of the applicant. It should not be reproduced except in full, without the written approval of our laboratory. The client should not use it to claim product endorsement by MOST. The test results in the report only apply to the tested sample. The test report shall be invalid without all the signatures of testing engineers, reviewer and approver.*

## TABLE OF CONTENTS

<b>1. VERIFICATION OF CONFORMITY .....</b>	<b>4</b>
<b>2. GENERAL INFORMATION.....</b>	<b>5</b>
2.1 Product Information.....	5
2.2 Objective.....	6
2.3 Test Standards and Results .....	6
2.4 Environmental Conditions.....	6
2.5 MEASUREMENT UNCERTAINTY .....	6
<b>3. TEST FACILITY .....</b>	<b>7</b>
3.2 Test Conditions .....	8
3.3 Channel List.....	8
3.4 Description of Test Modes.....	8
3.5 Table of Parameters of Text Software Setting.....	8
<b>4. TEST EQUIPMENT LIST .....</b>	<b>9</b>
<b>5. 47 CFR Part 15 C 15.247 Requirements.....</b>	<b>9</b>
<b>5.1 6dB Bandwidth .....</b>	<b>9</b>
5.1.1 Definition .....	9
5.1.2 Limit.....	9
5.1.3 Test Configuration.....	9
5.1.4 Test Procedure.....	9
5.1.5 Test Result.....	9
<b>5.2 Peak Output Power .....</b>	<b>9</b>
5.2.1 Definition .....	9
5.2.2 Limit.....	9
5.2.3 Test Configuration.....	9
5.2.4 Test Procedure.....	9
5.2.5 Test Result.....	9
<b>5.3 Conducted Spurious Emission .....</b>	<b>9</b>
5.3.1 Definition .....	9
5.3.2 Test Description .....	9
5.3.3 Test Result.....	9
<b>5.4 Band Edge .....</b>	<b>9</b>
5.4.1 Definition .....	9
5.4.2 Test Description .....	9
5.4.3 Test Configuration.....	9
5.4.4 Test Result.....	9
<b>5.5 Power Spectral Density (PSD).....</b>	<b>9</b>
5.5.1 Definition .....	9
5.5.2 Limit.....	9
5.5.3 Test Configuration.....	9
5.5.4 Test Description .....	9
5.5.5 Test Configuration.....	9
5.5.6 Operation Condition.....	9

5.5.7 Test Result..... 9

**5.6 Conducted Emission ..... 9**

5.6.1 Definition ..... 9

5.6.2 Test Description ..... 9

5.6.3 Test Result..... 9

**5.7 Radiated Emission ..... 9**

5.7.1 Definition ..... 9

5.7.2 Test Description ..... 9

5.7.3 Test Result..... 9

**APPENDIX 1 ..... 9**

**PHOTOGRAPHS OF TEST SETUP ..... 9**

# 1. VERIFICATION OF CONFORMITY

**Equipment Under Test:** Full HD Cludio TV Set-Top Box

**Brand Name:** SKYWORTH

**Model Number:** HPM5

**Series Model Number:** A6

**FCC ID:** WNA-A6

**Applicant:** Shenzhen Skyworth Digital Technology Co., LTD.  
Unit A14/F.Skyworth Building.,Gaoxin Ave.1s.,Nanshan District, Shenzhen,China

**Manufacturer:** Shenzhen Skyworth Digital Technology Co.,LTD.  
Unit A14/F.Skyworth Building.,Gaoxin Ave.1s.,Nanshan District, Shenzhen,China

**Technical Standards:** 47 CFR Part 15 Subpart C

**File Number:** MTE/DAL/T13091303

**Date of test:** Sep. 25-27, 2013

**Deviation:** None

**Condition of Test Sample:** Normal

**Test Result:** PASS

The above equipment was tested by *MOST* for compliance with the requirements set forth in FCC rules and the Technical Standards mentioned above. This said equipment in the configuration described in this report shows the maximum emission levels emanating from equipment and the level of the immunity endurance of the equipment are within the compliance requirements.

The test results of this report relate only to the tested sample identified in this report.

Prepared by (+ signature):

*Dona*

---

Dona Liu Sep. 26, 2012

Review by (+ signature):

*Elva*

---

Elva Wong Sep. 26, 2013



Approved by (+ signature):

*Yvette*

---

Yvette Zhou Sep. 27, 2013

## 2. GENERAL INFORMATION

### 2.1 Product Information

Description:	Full HD Cloudio TV Set-Top Box
Model Name:	HPM5
Series Number:	A6
Model Difference description:	Outlook is different, PCBA is same
Frequency Range:	802.11b/g/n(20MHz): 2412-2462MHz 802.11n(40MHz): 2422-2452MHz
Number of Channels:	IEEE 802.11b/g/n(20MHz)mode:11 Channels IEEE 802.11n(40MHz)mode: 9 Channels
Modulation Technique:	IEEE 802.11b mode: DSSS IEEE 802.11g mode: OFDM 802.11n Standard-20 MHz Channel mode: OFDM 802.11n Standard-40 MHz Channel mode: OFDM
Antenna Type:	Internal Fixed
Antenna Gain:	0.0dBi
Power Supply:	DC 12V by AC adapter AC 120V 60Hz
Temperature Range:	0°C ~ +45°C

**NOTE:**

1. For a more detailed features description about the EUT, please refer to User's Manual.

## 2.2 Objective

Perform FCC Part 15 Subpart C tests for FCC Marking.

## 2.3 Test Standards and Results

Test items and the results are as bellow:

No.	Section	Description	Result	Date of Test
1	15.247(a)(2)	6dB Bandwidth	PASS	2013/09/13
2	15.247(b)(3)	Peak Output Power	PASS	2013/09/13
3	15.247(d)	conducted spurious emission	PASS	2013/09/13
4	15.247(d)	Band Edge	PASS	2013/09/12
5	15.247(e)	Power Spectral Density	PASS	2013/09/13
6	15.207	Conducted Emission	PASS	2013/09/12
7	15.247(d) 15.205 15.209	Radiated Emission	PASS	2013/09/12

Note: 1. The test result judgment is decided by the limit of measurement standard  
2. The information of measurement uncertainty is available upon the customer's request.

## 2.4 Environmental Conditions

During the measurement the environmental conditions were within the listed ranges:

- Temperature: 15-35°C
- Hu7" Internet Tabletity: 30-60 %
- Atmospheric pressure: 86-106 kPa

## 2.5 MEASUREMENT UNCERTAINTY

The uncertainty is calculated using the methods suggested in the "Guide to the Expression of Uncertainty in Measurement" (GUM) published by ISO.

The report uncertainty of measurement  $y \pm U$ , where expended uncertainty  $U$  is based on a standard uncertainty multiplied by a coverage factor of  $k=2$ , Providing a level of confidence of approximately 95%

- Uncertainty of Conducted Emission,  $U_c = \pm 1.8\text{dB}$
- Uncertainty of Radiated Emission,  $U_c = \pm 3.2\text{dB}$

### 3. TEST FACILITY

Test Site:	Most Technology Service Co., Ltd.
Location:	No.5, Nangshan 2nd Rd., North Hi-Tech Industrial park, Nanshan, Shenzhen, Guangdong, China
Description:	<p>There is one 3m semi-anechoic an area test sites and two line conducted labs for final test. The Open Area Test Sites and the Line Conducted labs are constructed and calibrated to meet the FCC requirements in documents ANSI C63.4 and CISPR 16 requirements.</p> <p>The FCC Registration Number is <b>490827</b>.</p>
Site Filing:	The site description is on file with the Federal Communications Commission, 7435 Oakland Mills Road, Columbia, MD 21046.
Instrument Tolerance:	All measuring equipment is in accord with ANSI C63.4 and CISPR 16 requirements that meet industry regulatory agency and accreditation agency requirement.
Ground Plane:	Two conductive reference ground planes were used during the Line Conducted Emission, one in vertical and the other in horizontal. The dimensions of these ground planes are as below. The vertical ground plane was placed distancing 40 cm to the rear of the wooden test table on where the EUT and the support equipment were placed during test. The horizontal ground plane projected 50 cm beyond the footprint of the EUT system and distanced 80 cm to the wooden test table. For Radiated Emission Test, one horizontal conductive ground plane extended at least 1m beyond the periphery of the EUT and the largest measuring antenna, and covered the entire area between the EUT and the antenna. It has no holes or gaps having longitudinal dimensions larger than one-tenth of a wavelength at the highest frequency of measurement up to 1GHz.
558074 D01 DTS Meas Guidance v01 :	provides Guidance for Performing Compliance Measurements on Digital Transmission Systems (DTS) Operating Under CFR Title 47 15.247

### 3.2 Test Conditions

The EUT has been tested under normal operating (TX) and standby (RX) condition.

The field strength of radiation emission was measured in the following position: EUT lie-down position (X, Z axis).

The worst case of X axis was reported.

Based on client request, all normal using modes of the normal function were tested but only the worst test data of the worst mode is reported by this report.

### 3.3 Channel List

Channel List for 802.11b/g/n(20MHz)					
Channel	Frequency (MHz)	Channel	Frequency (MHz)	Channel	Frequency (MHz)
01	2412MHz	05	2432MHz	09	2452MHz
02	2417MHz	06	2437MHz	10	2457MHz
03	2422MHz	07	2442MHz	11	2462MHz
04	2427MHz	08	2447MHz		

### 3.4 Description of Test Modes

To investigate the maximum EMI emission characteristics generates from EUT, the test system was pre-scanning tested base on the consideration of following EUT operation mode or test configuration mode which possible have effect on EMI emission level, Each of these EUT operation mode(s) or test configuration mode(s) mentioned above was evaluated respectively

Pre-test Mode	Description
Mode 1	802.11b CH01/CH06/CH11
Mode 2	802.11g CH01/CH06/CH11
Mode 3	802.11n(20MHz)CH01/CH06/CH11
Mode 4	802.11n(40MHz)CH03/CH06/CH09

Note:

- (1) The measurements are performed at the highest, middle, lowest available channels.
- (2) The measurements are performed at all bit rate of transmitter, the worst data was reported.

### 3.5 Table of Parameters of Text Software Setting

During testing channel & power controlling software provided by the customer was used to control the operating channel as well as the output power level, the RF output power selection is for the setting of RF output power expected by the customer and is going to be fixed on the firmware of the final end product power parameters of WLAN

Test software Version	Test Channels		
802.11b	2412MHz	2437MHz	2462MHz
802.11g	2412MHz	2437MHz	2462MHz
802.11n(20MHz)	2412MHz	2437MHz	2462MHz
802.11n(40MHz)	2422MHz	2437MHz	2452MHz



#### 4. TEST EQUIPMENT LIST

**Instrumentation:** The following list contains equipment used at MOST for testing. The equipment conforms to the CISPR 16-1/ANSI C63.2 Specifications for Electromagnetic Interference and Field Strength Instrumentation from 10 kHz to 1.0 GHz or above.

No.	Equipment	Manufacturer	Model No.	S/N	Calibration date	Calibration Interval
1	Test Receiver	Rohde & Schwarz	ESCI	100492	2013/03/10	1 Year
2	Spectrum Analyzer	Agilent	E7405A	US44210471	2013/03/14	1 Year
3	L.I.S.N.	Rohde & Schwarz	ENV216	100093	2013/03/10	1 Year
4	Coaxial Switch	Anritsu Corp	MP59B	6200283933	2013/03/07	1 Year
5	Terminator	Hubersuhner	50Ω	No.1	2013/03/07	1 Year
6	RF Cable	SchwarzBeck	N/A	No.1	2013/03/07	1 Year
7	Test Receiver	Rohde & Schwarz	ESPI	101202	2013/03/10	1 Year
8	Bilog Antenna	Sunol	JB3	A121206	2013/03/14	1 Year
9	Horn Antenna	SCHWARZBECK	BBHA9120D	756	2013/03/14	1 Year
10	Horn Antenna	Penn Engineering	9034	8376	2013/03/14	1 Year
11	Cable	Resenberger	N/A	NO.1	2013/03/07	1 Year
12	Cable	SchwarzBeck	N/A	NO.2	2013/03/07	1 Year
13	Cable	SchwarzBeck	N/A	NO.3	2013/03/07	1 Year
14	DC Power Filter	DuoJi	DL2×30B	N/A	2013/03/07	1 Year
15	Single Phase Power Line Filter	DuoJi	FNF 202B30	N/A	2013/03/07	1 Year
16	3 Phase Power Line Filter	DuoJi	FNF 402B30	N/A	2013/03/07	1 Year
17	Test Receiver	Rohde & Schwarz	ESCI	100492	2013/03/10	1 Year
18	Absorbing Clamp	Luthi	MDS21	3635	2013/03/12	1 Year
19	Coaxial Switch	Anritsu Corp	MP59B	6200283933	2013/03/07	1 Year
20	AC Power Source	Kikusui	AC40MA	LM003232	2013/03/10	1 Year
21	Test Analyzer	Kikusui	KHA1000	LM003720	2013/03/10	1 Year
22	Line Impedence Network	Kikusui	LIN40MA-PCR-L	LM002352	2013/03/10	1 Year
23	ESD Tester	Kikusui	KES4021	LM003537	2013/03/07	1 Year
24	EMC PRO System	EM Test	UCS-500-M4	V0648102026	2013/03/10	1 Year
25	Signal Generator	IFR	2032	203002/100	2013/03/10	1 Year
26	Amplifier	A&R	150W1000	301584	2013/03/14	1 Year
27	CDN	FCC	FCC-801-M2-25	47	2013/03/10	1 Year
28	CDN	FCC	FCC-801-M3-25	107	2013/03/10	1 Year
29	EM Injection Clamp	FCC	F-203I-23mm	403	2013/03/10	1 Year
30	RF Cable	MIYAZAKI	N/A	No.1/No.2	2013/03/10	1 Year
31	Universal Radio Communication Tester	ROHDE&SCHWARZ	CMU200	0304789	2013/03/10	1 Year
32	Telecommunication Antenna	European Antennas	PSA 75301R/170	0304213	2013/03/10	1 Year
33	8 Loop Antenna	ARA	PLA-1030/B	1029	2013/02/19	1 Year
34	Power Meter	R&S	NRVS	100696	2013/07/06	1 Year
35	Power Sensor(AV)	R&S	URV5-Z4	0395.1619.05	2013/07/06	1 Year

**NOTE:** Equipments listed above have been calibrated and are in the period of validation.

## 5. 47 CFR Part 15 C 15.247 Requirements

### 5.1 6dB Bandwidth

#### 5.1.1 Definition

Systems using digital modulation techniques may operate in the 902–928 MHz, 2400–2483.5 MHz, and 5725–5850 MHz bands. The minimum 6 dB bandwidth shall be at least 500 kHz.

#### 5.1.2 Limit

FCC Part15(15.247)				
Section	Test Item	Limit	Frequency Range(MHz)	Result
15.247(a)(2)	Bandwidth	$\geq 500\text{KHz}$ (6dB Bandwidth)	2400-2483.5	PASS

#### 5.1.3 Test Configuration

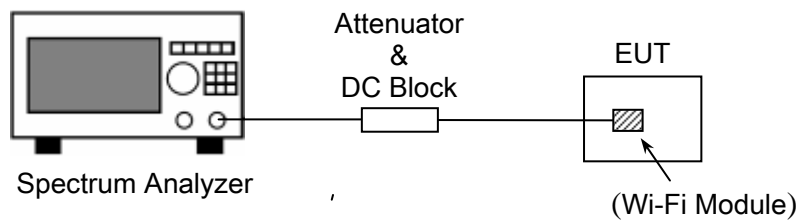

Figure 1: RF Test Setup

#### 5.1.4 Test Procedure

Spectrum Parameters	Setting
Attenuation	Auto
Span Frequency	$>$ Measurement bandwidth or channel separation
RB	1-5% of the emission bandwidth(EBW)
VB	$\geq 3 \times \text{RBW}$
Detector	Peak
Trace	Max Hold
Sweep Time	Auto

The EUT is powered by the Battery, is coupled to the Spectrum Analyzer (SA) through the Attenuator/DC Block. The path loss as the factor is calibrated to correct the reading. During the measurement, the EUT is activated and is set to operate at maximum power. The RF load attached to the EUT antenna terminal is 50Ohm.

#### 5.1.5 Test Result

The lowest, Middle and highest channels are selected to perform testing to record the 6 dB bandwidth of the Module.

##### 5.1.5.1 802.11b Test Mode

The minimum occupied bandwidth for the fundamental frequency 2437 MHz is 10.076 MHz. This occupied bandwidth complies with the FCC requirement.

**A. Test Verdict:**

Channel	Frequency (MHz)	6 dB Bandwidth (MHz)	Limits (kHz)	Result
1	2412	10.045	≥500	PASS
6	2437	10.076	≥500	PASS
11	2462	10.054	≥500	PASS

**B. Test Plot:**

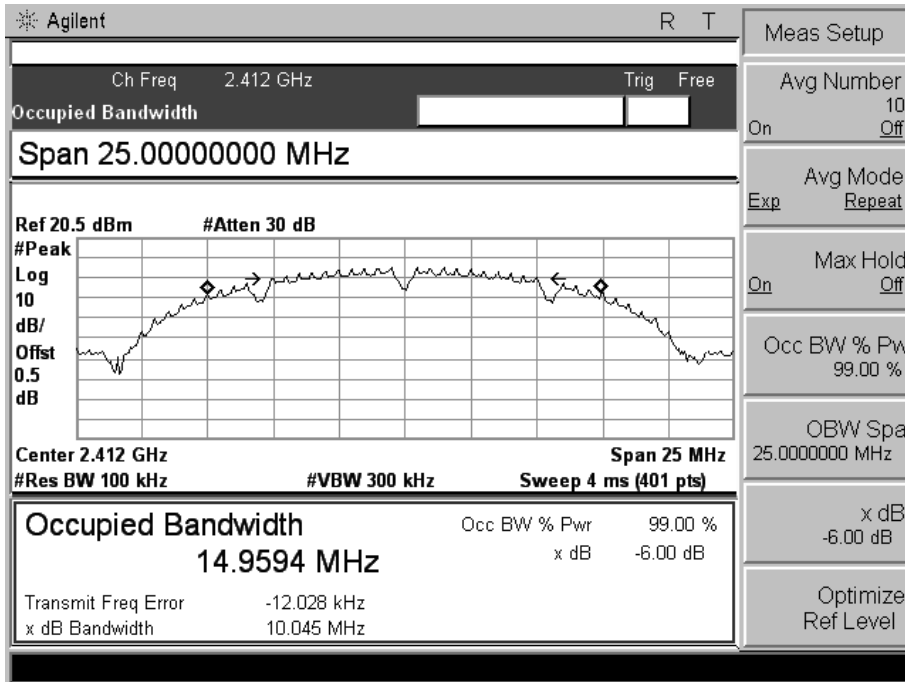

(CH Low)

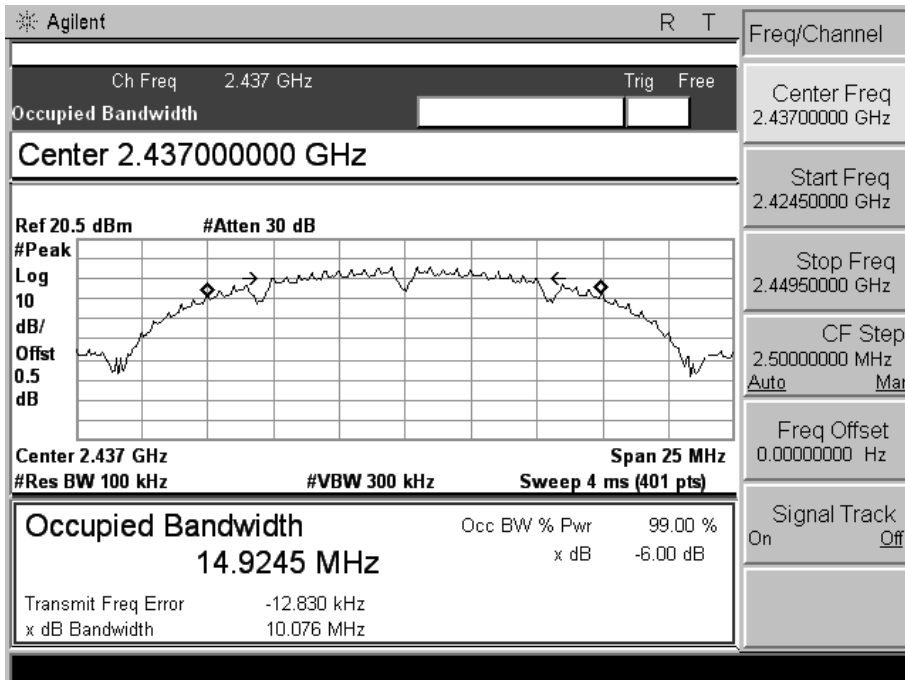

(CH Mid)

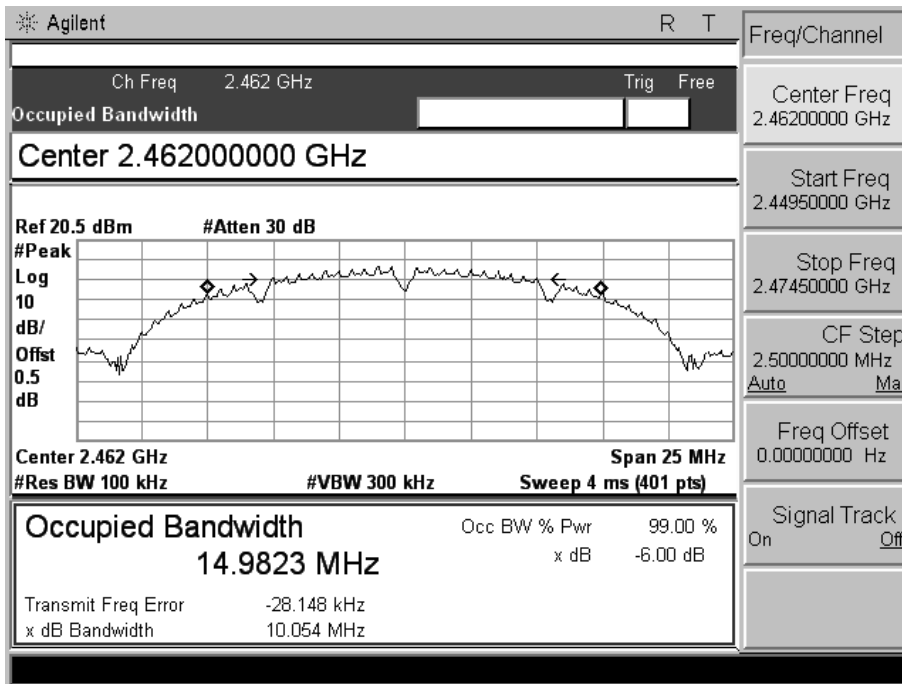

(CH High)

### 5.1.5.2 802.11g Test Mode

The minimum occupied bandwidth for the fundamental frequency 2437MHz is 16.403MHz. This occupied bandwidth complies with the FCC requirement.

#### A. Test Verdict:

Channel	Frequency (MHz)	6 dB Bandwidth (MHz)	Limits (kHz)	Result
1	2412	16.392	≥500	PASS
6	2437	16.403	≥500	PASS
11	2462	16.401	≥500	PASS

#### B. Test Plot:

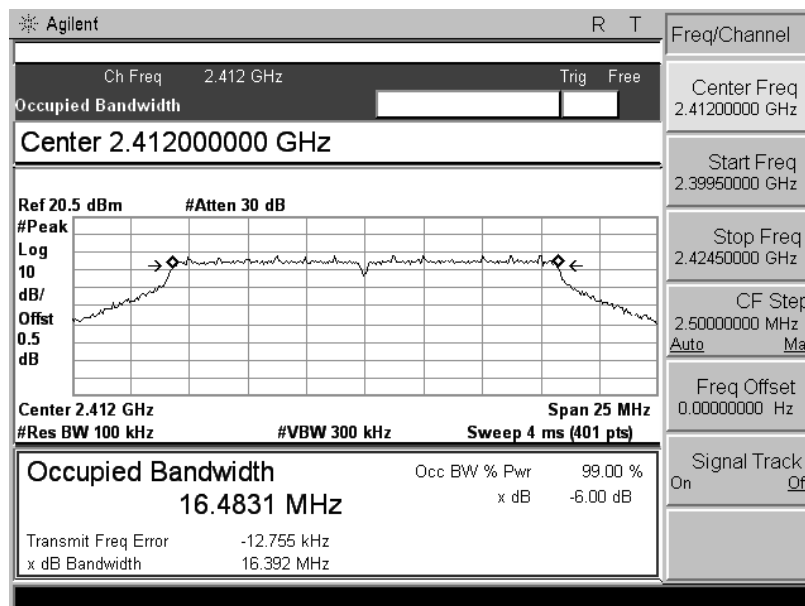

(CH Low)

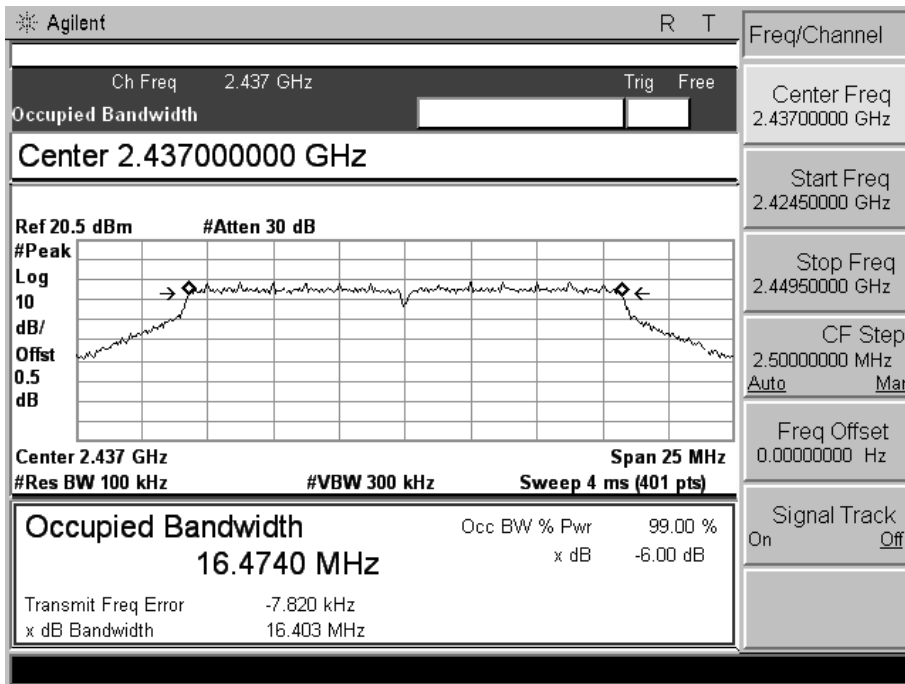

(CH Mid)

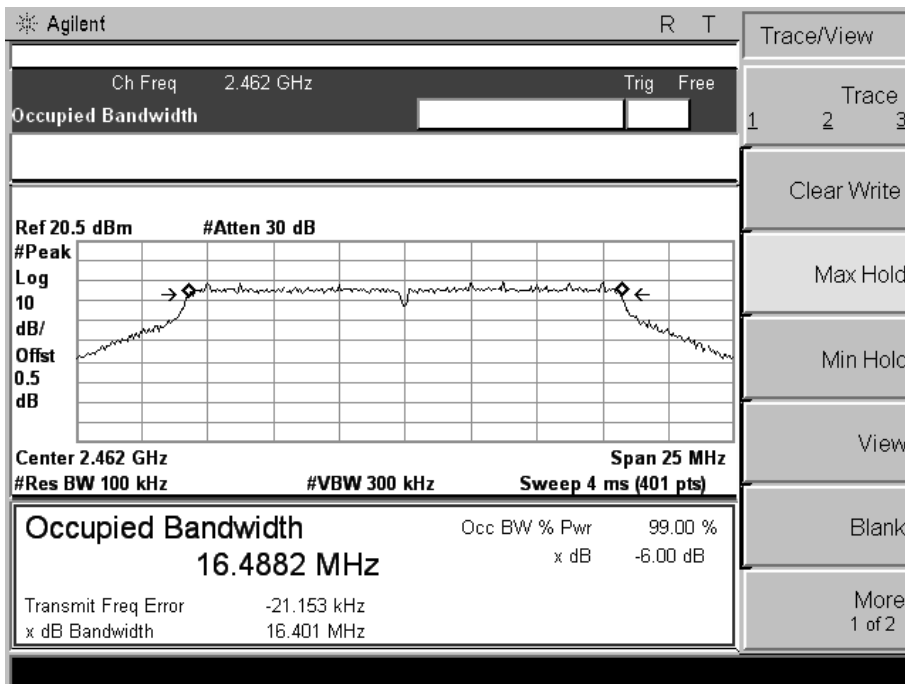

(CH High)

### 5.1.5.3 802.11n(20MHz) Test Mode

The minimum occupied bandwidth for the fundamental frequency 2412MHz is 17.619MHz. This occupied bandwidth complies with the FCC requirement.

#### A. Test Verdict:

Channel	Frequency (MHz)	6 dB Bandwidth (MHz)	Limits (kHz)	Result
1	2412	17.619	≥500	PASS
6	2437	17.603	≥500	PASS
11	2462	17.616	≥500	PASS

#### B. Test Plot:

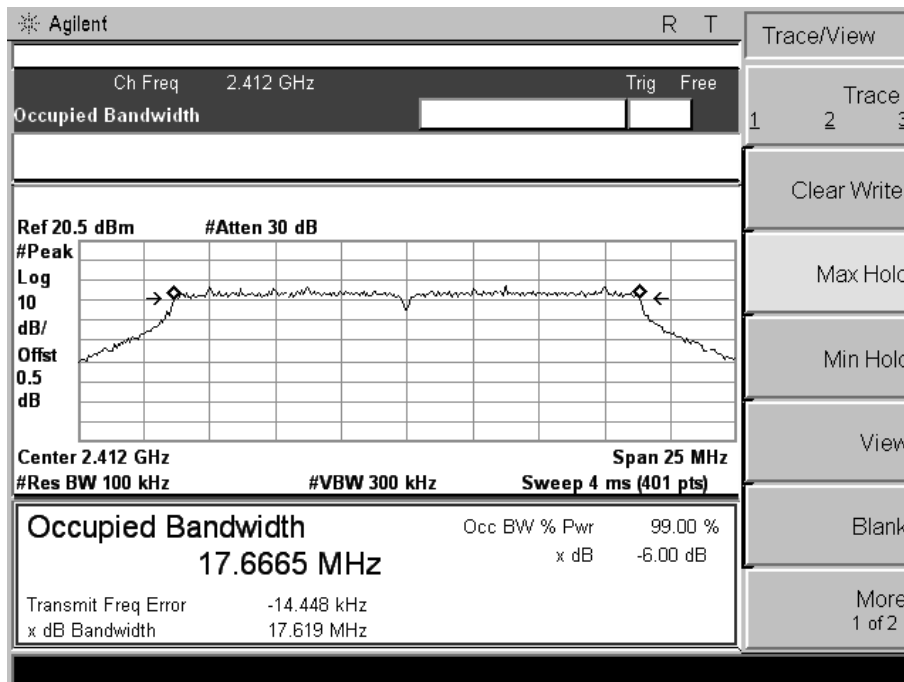

(CH Low)

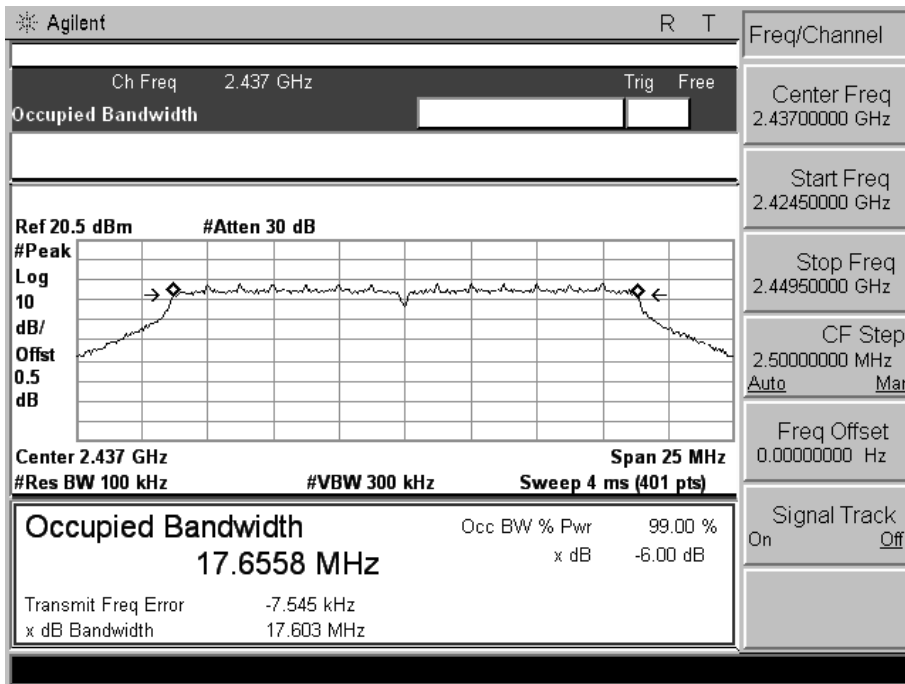

(CH Mid)

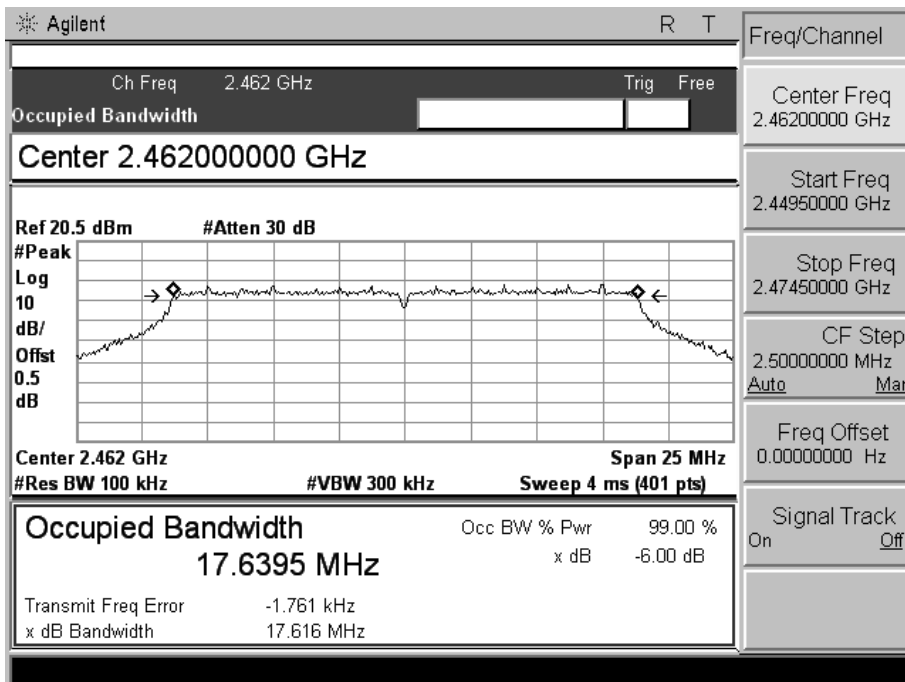

(CH High)

### 5.1.5.4 802.11n Test Mode(40MHz)

The minimum occupied bandwidth for the fundamental frequency 2452MHz is 35.648MHz. This occupied bandwidth complies with the FCC requirement.

#### A. Test Verdict:

Channel	Frequency (MHz)	6 dB Bandwidth (MHz)	Limits (kHz)	Result
3	2422	35.600	≥500	PASS
6	2437	35.631	≥500	PASS
9	2452	35.648	≥500	PASS

#### B. Test Plot:

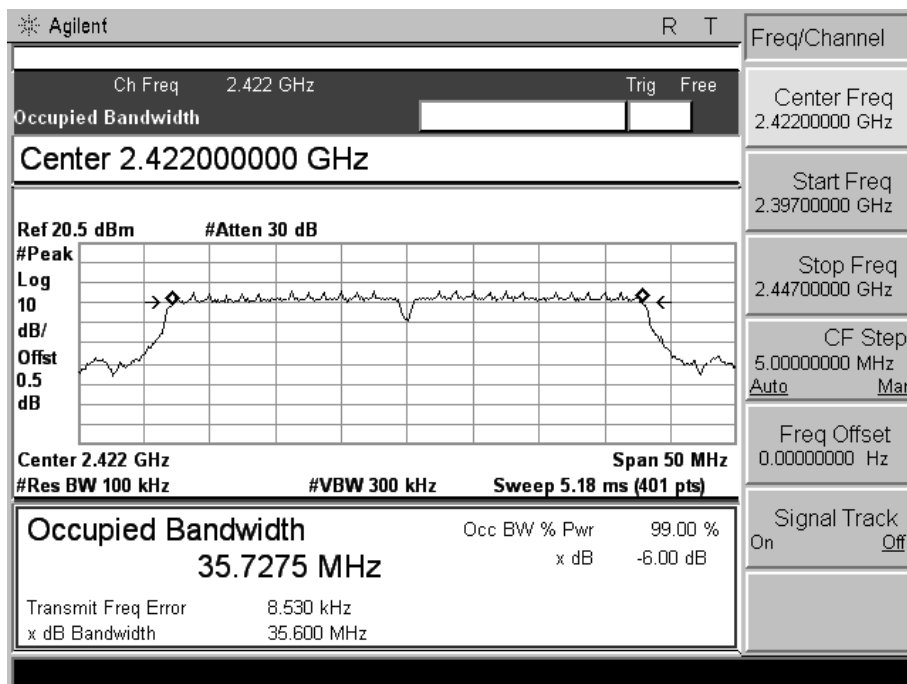

(CH Low)



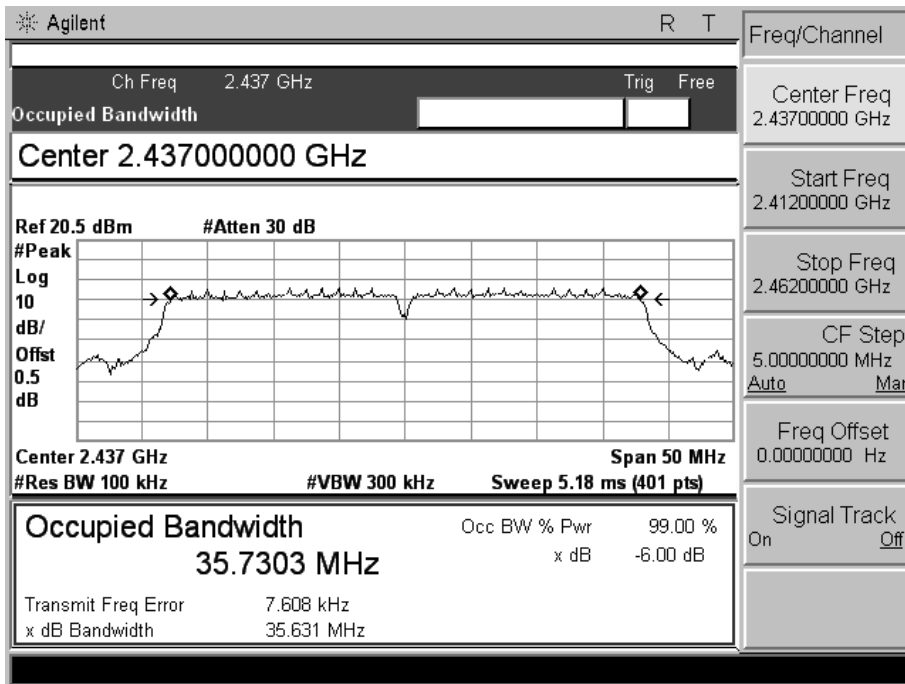

(CH Mid)

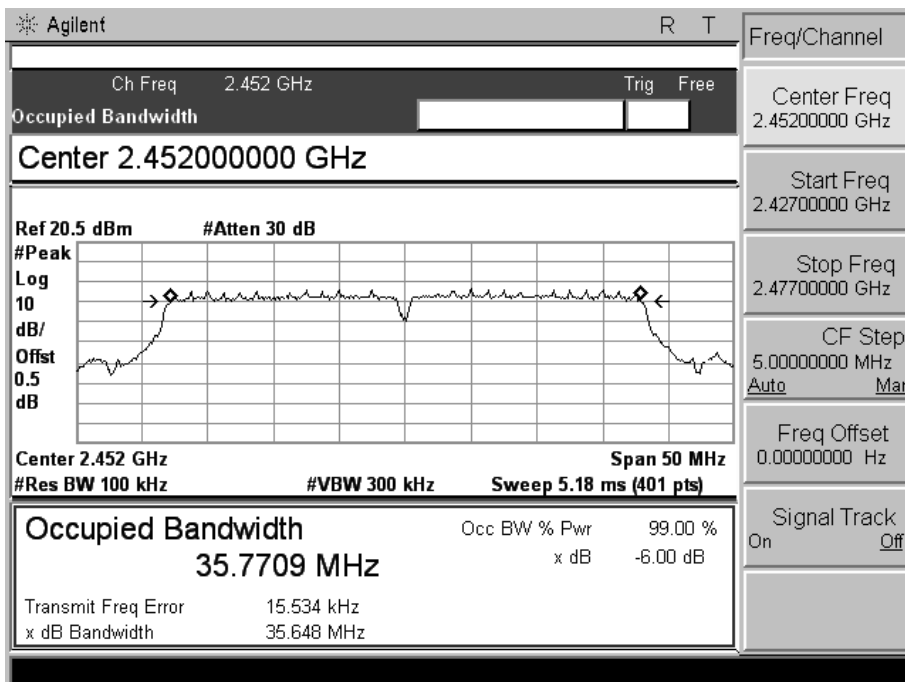

(CH High)

## 5.2 Peak Output Power

### 5.2.1 Definition

For systems using digital modulation in the 902–928 MHz, 2400–2483.5 MHz, and 5725–5850 MHz bands: 1 Watt. As an alternative to a peak power measurement, compliance with the one Watt limit can be based on a measurement of the maximum conducted output power.

### 5.2.2 Limit

FCC Part15(15.247)				
Section	Test Item	Limit	Frequency Range(MHz)	Result
15.247(b)(1)	Peak Output Power	30dBm	2400-2483.5	PASS

### 5.2.3 Test Configuration

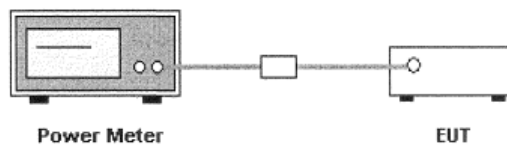

### 5.2.4 Test Procedure

The EUT which is powered by AC adapter, is coupled to the Power Meter; the RF load attached to the EUT antenna terminal is 50Ohm; the path loss as the factor is calibrated to correct the reading.

### 5.2.5 Test Result

The EUT operates at maximum output power mode. The lowest, Middle and highest channels are selected to perform testing to verify the conducted RF output peak power of the Module.

#### 5.2.5.1 802.11b Test Mode

The maximum output power for the fundamental frequency 2462MHz is 18.23dBm. This power complies with the FCC requirement.

##### A. Test Verdict:

Channel	Frequency (MHz)	Peak Output Power	Limit		Verdict
		dBm	dBm	W	
1	2412	17.24	30	1	PASS
6	2437	17.72			PASS
11	2462	18.23			PASS

#### 5.2.5.2 802.11g Test Mode

The maximum output power for the fundamental frequency 2462 MHz is 15.88dBm. This power complies with the FCC requirement.

##### A. Test Verdict:

Channel	Frequency (MHz)	Peak Output Power	Limit		Verdict
		dBm	dBm	W	
1	2412	14.91	30	1	PASS
6	2437	15.32			PASS
11	2462	15.88			PASS

**5.2.5.3 802.11n(20MHz) Test Mode**

The maximum output power for the fundamental frequency 2462 MHz is 14.97dBm. This power complies with the FCC requirement.

**A. Test Verdict:**

Channel	Frequency (MHz)	Peak Output Power	Limit		Verdict
		dBm	dBm	W	
1	2412	13.89	30	1	PASS
6	2437	14.31			PASS
11	2462	14.97			PASS

**5.2.5.4 802.11n Test Mode (40MHz)**

The maximum output power for the fundamental frequency 2462 MHz is 13.28dBm. This power complies with the FCC requirement.

**B. Test Verdict:**

Channel	Frequency (MHz)	Peak Output Power	Limit		Verdict
		dBm	dBm	W	
1	2412	13.34	30	1	PASS
6	2437	13.13			PASS
11	2462	13.28			PASS

### 5.3 Conducted Spurious Emission

#### 5.3.1 Definition

In any 100 kHz bandwidth outside the frequency band in which the spread spectrum or digitally modulated intentional radiator is operating, the radio frequency power that is produced by the intentional radiator shall be at least 20 dB below that in the 100 kHz bandwidth within the band that contains the highest level of the desired power, based on either an RF conducted or a radiated measurement, provided the transmitter demonstrates compliance with the peak conducted power limits.

#### 5.3.2 Test Description

See section 5.1.2 of this report.

#### 5.3.3 Test Result

The measurement frequency range is from 30MHz to the 10th harmonic of the fundamental frequency. The lowest, middle and highest channels are tested to verify the spurious emissions.

##### 5.3.3.1 802.11b Test Mode

Test Plot:

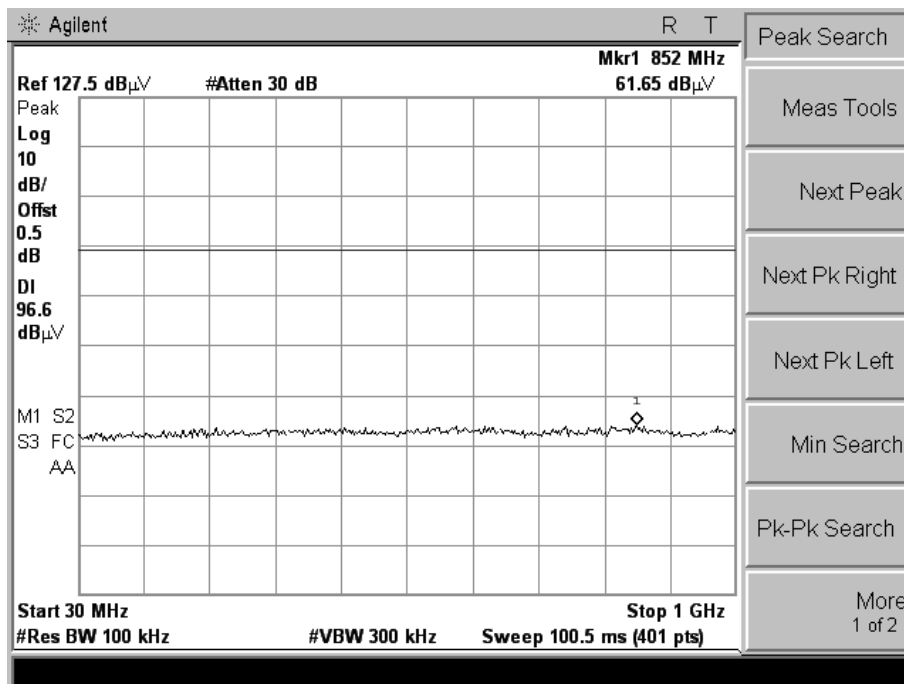

(CH Low, 9kHz to 1GHz)

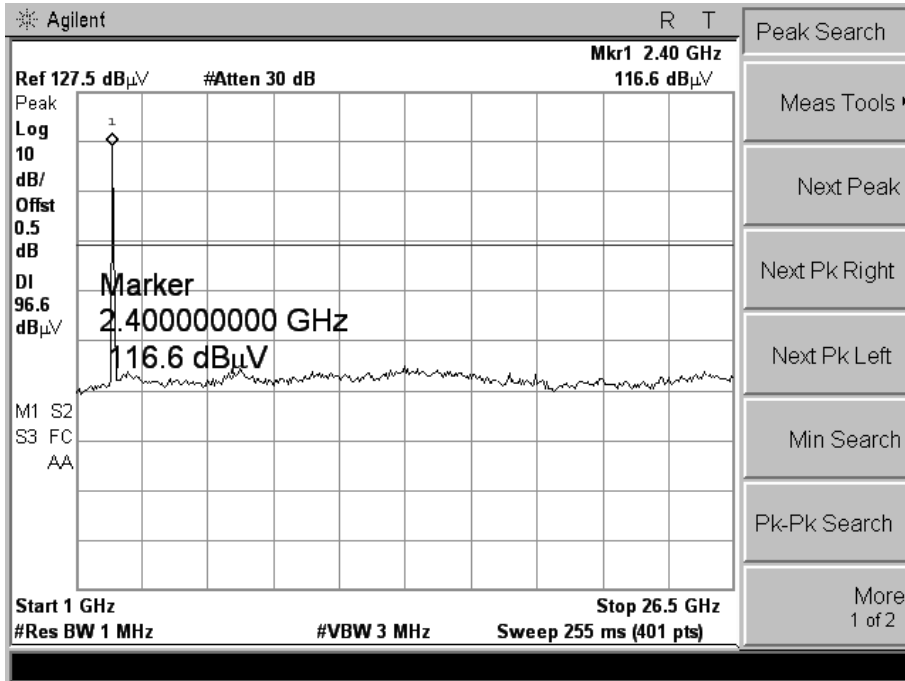

(CH Low, 1GHz to 26.5GHz)

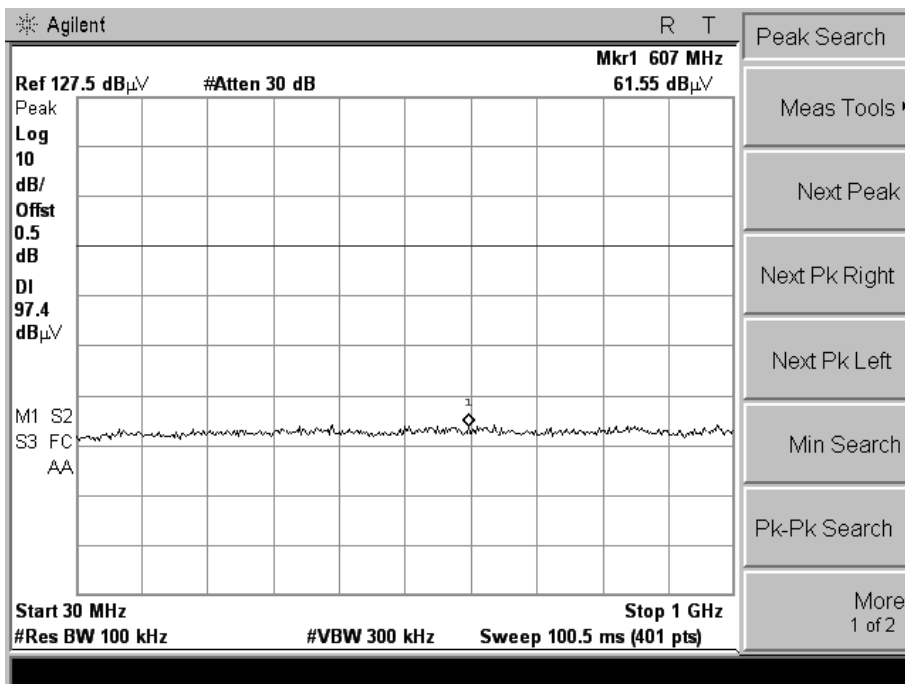

(CH Mid, 9kHz to 1GHz)

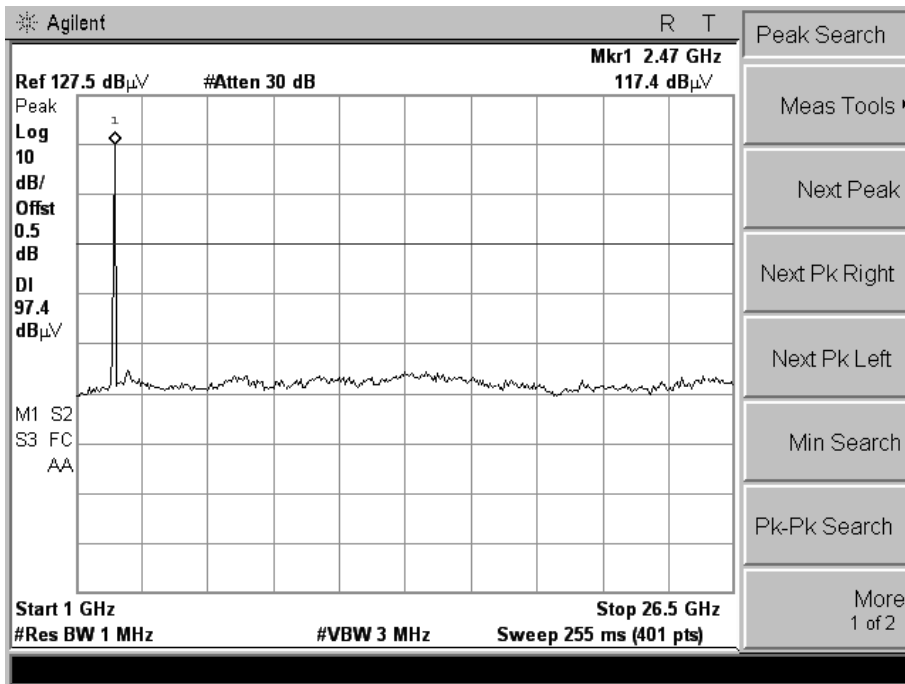

(CH Mid, 1GHz to 26.5GHz)

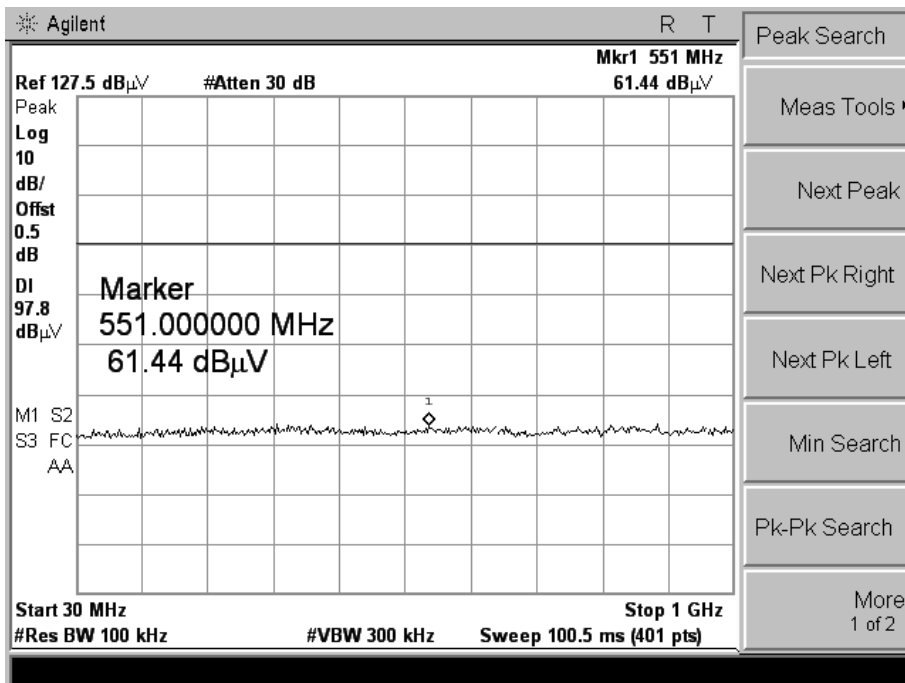

(CH High, 9kHz to 1GHz)

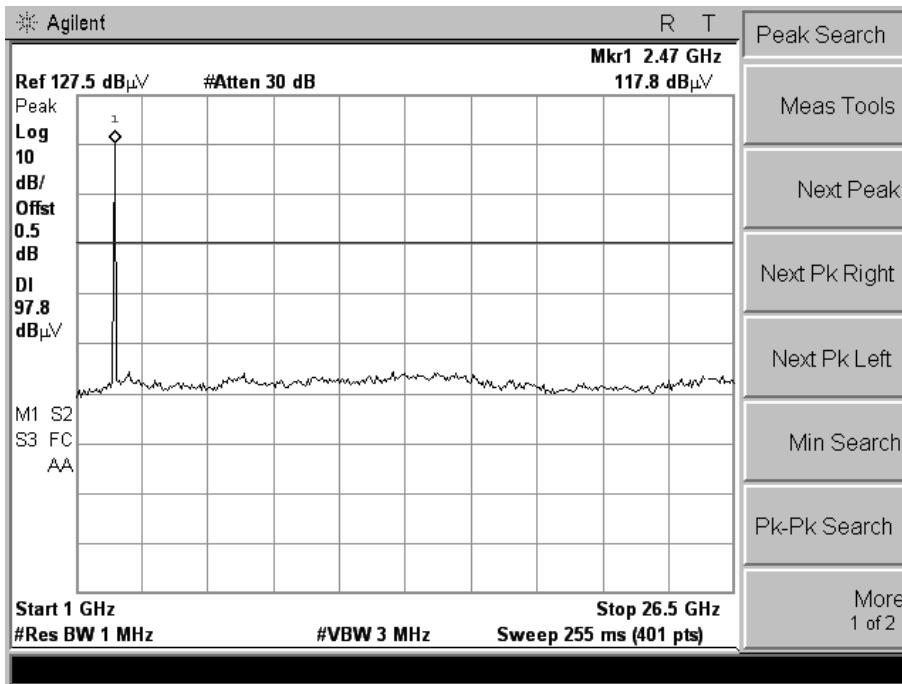

(CH High, 1GHz to 26.5GHz)

**Note:**

1. The power of the Module transmitting frequency should be ignored.

**5.3.2. 802.11g Test Mode**

**Test Plot:**

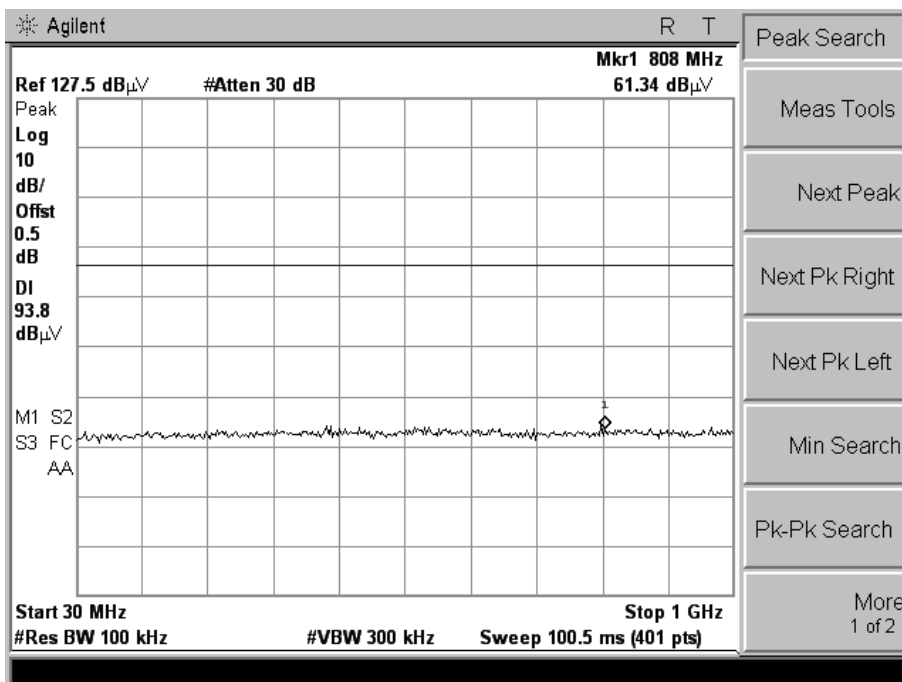

(CH Low, 9kHz to 1GHz)

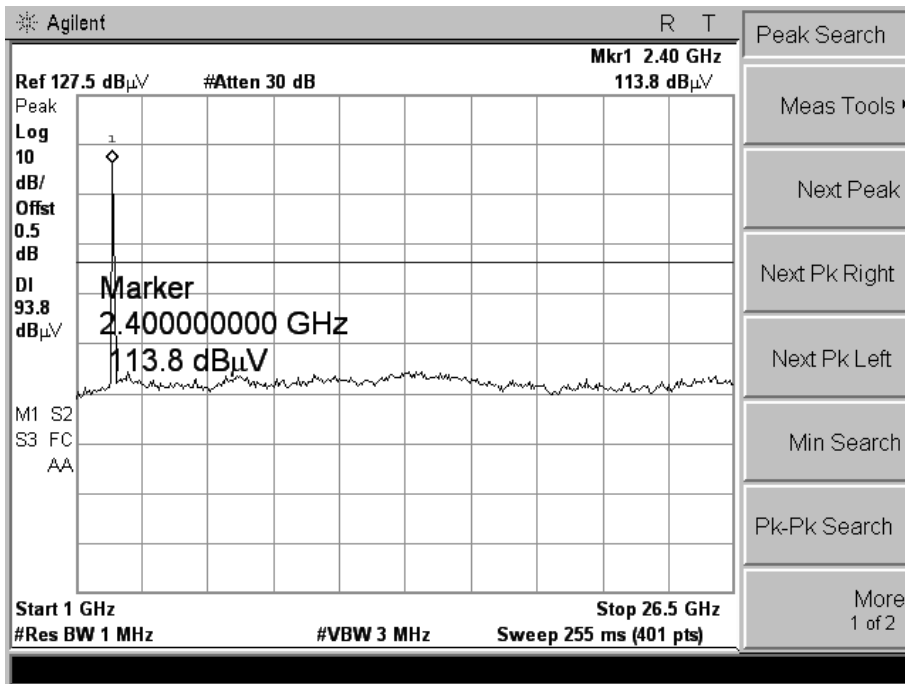

(CH Low, 1GHz to 26.5GHz)

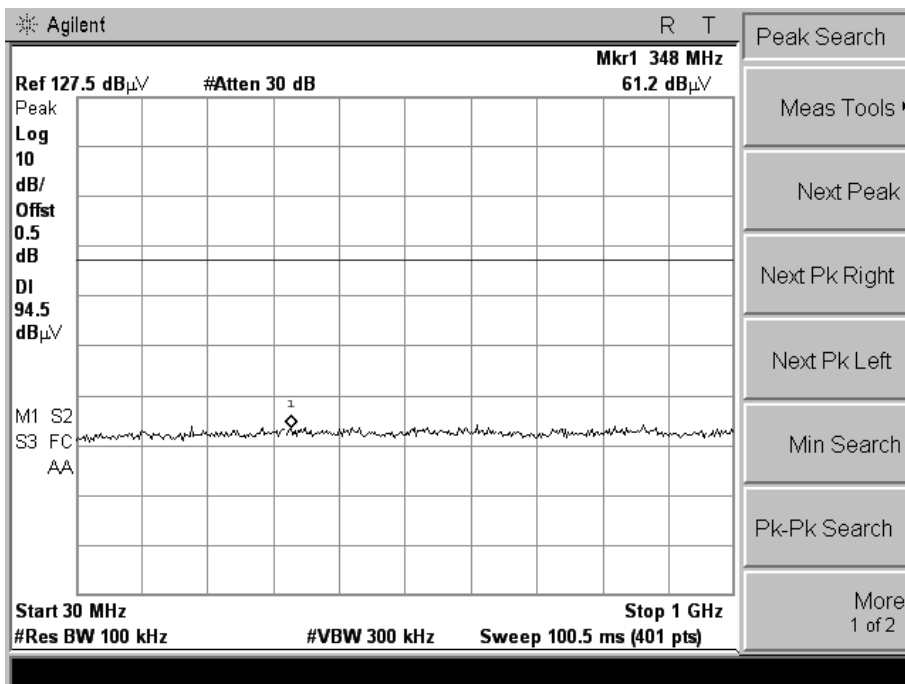

(CH Mid, 9kHz to 1GHz)



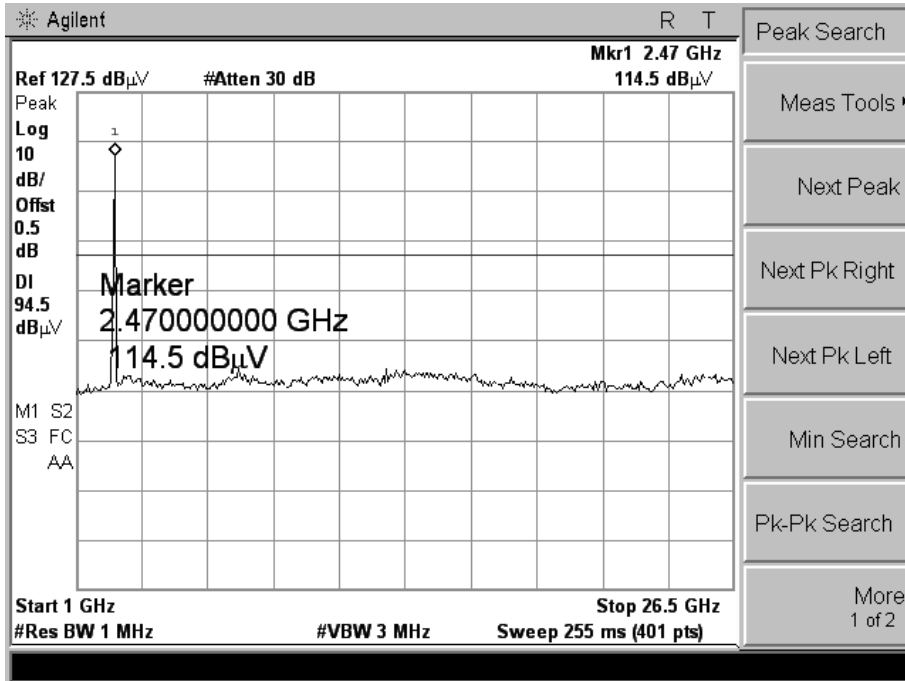

(CH Mid, 1GHz to 26.5GHz)

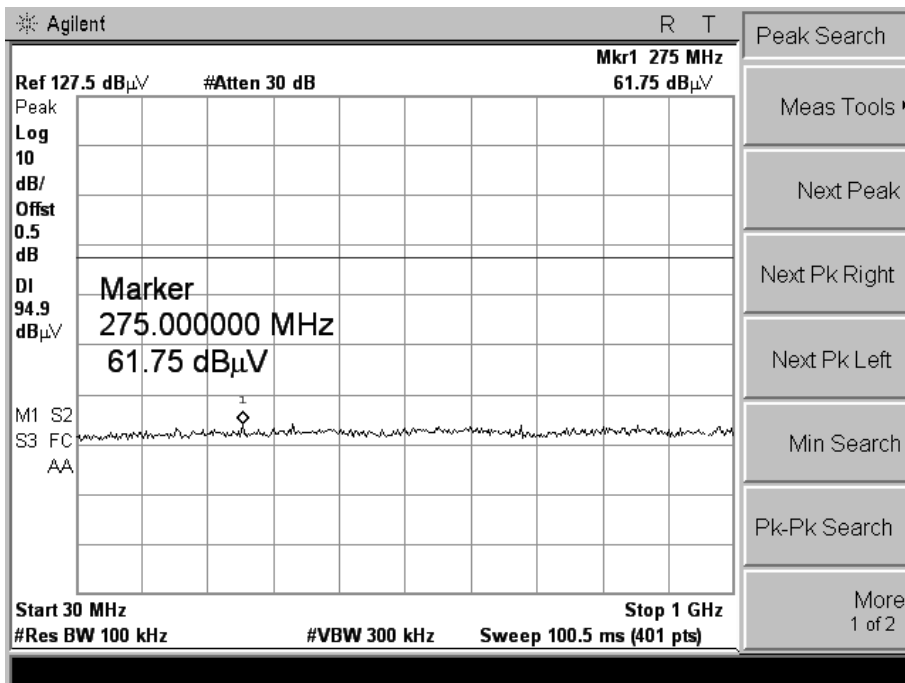

(CH High, 9kHz to 1GHz)

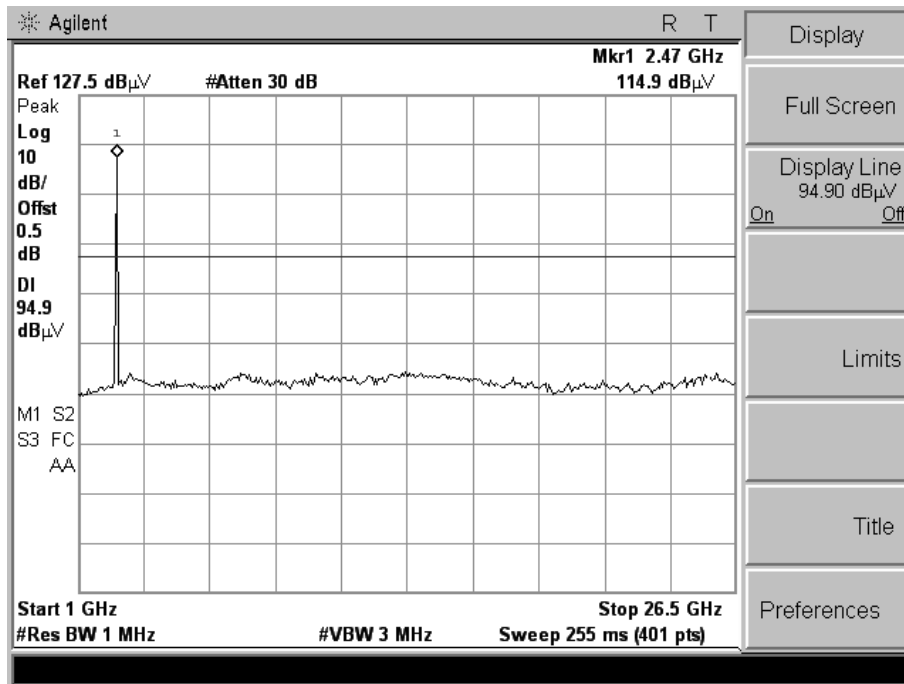

(CH High, 1GHz to 26.5GHz)

**Note:**

1. The power of the Module transmitting frequency should be ignored.

**5.3.3. 802.11n(20MHz) Test Mode**

**Test Plot:**

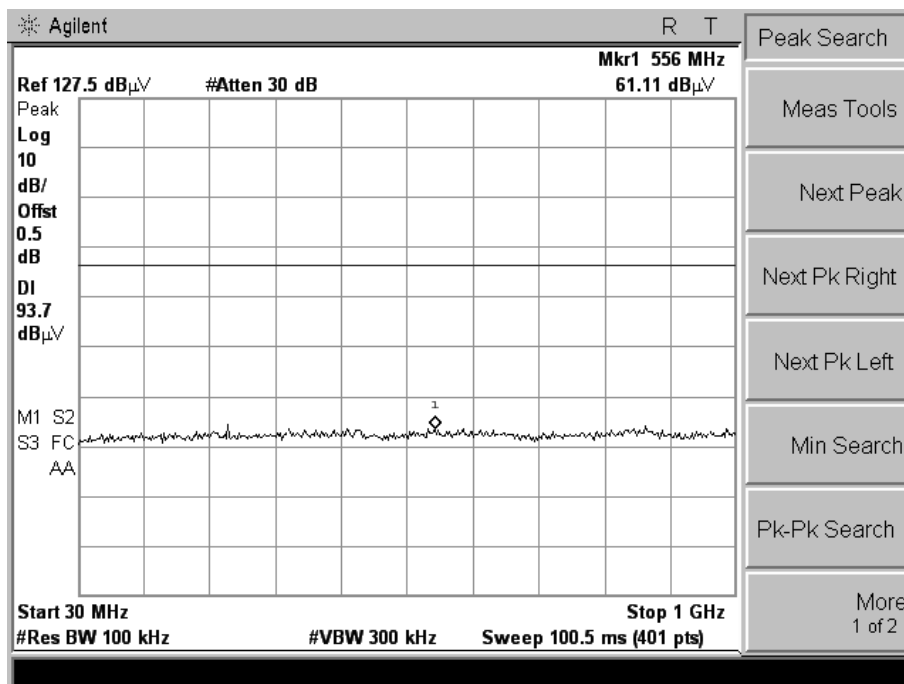

(CH Low, 9kHz to 1GHz)

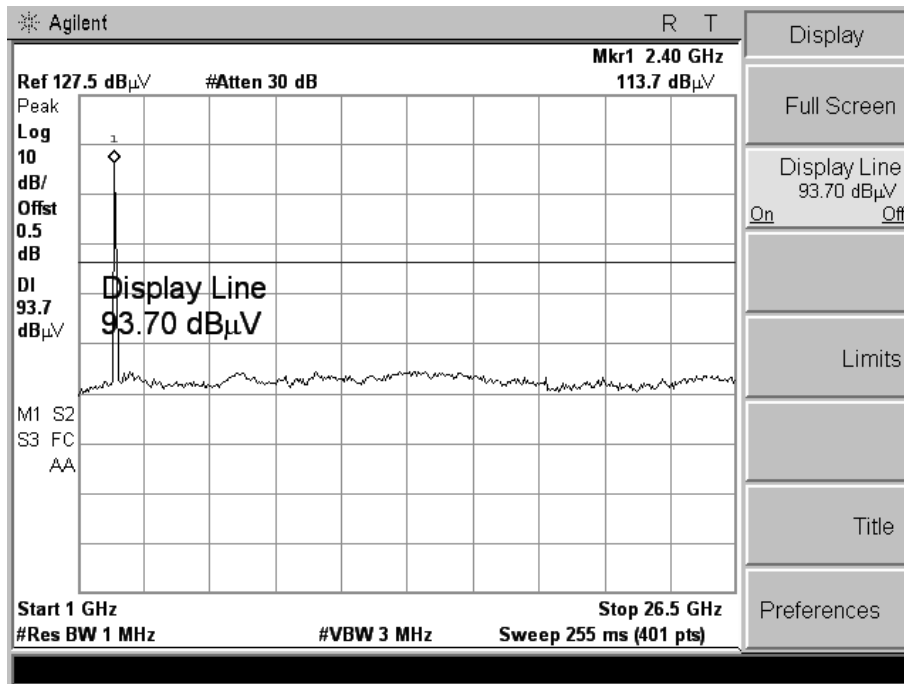

(CH Low, 1GHz to 26.5GHz)

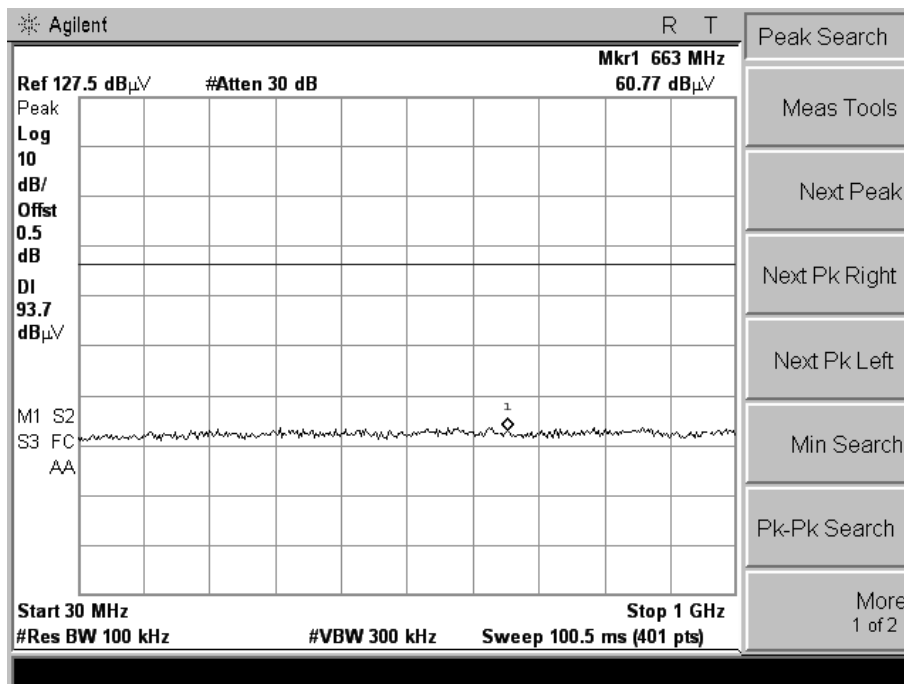

(CH Mid, 9kHz to 1GHz)

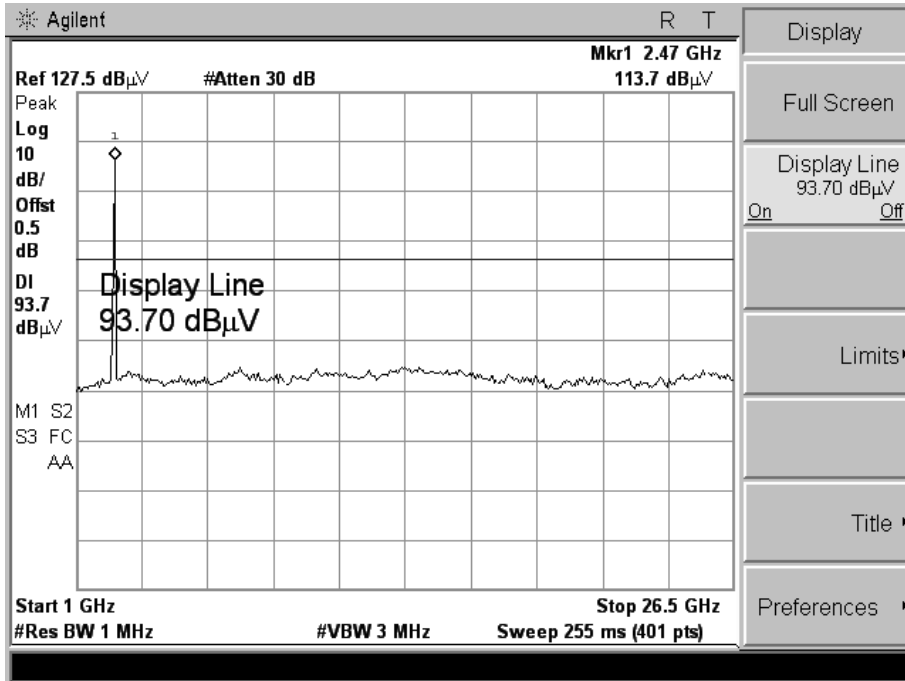

(CH Mid, 1GHz to 26.5GHz)

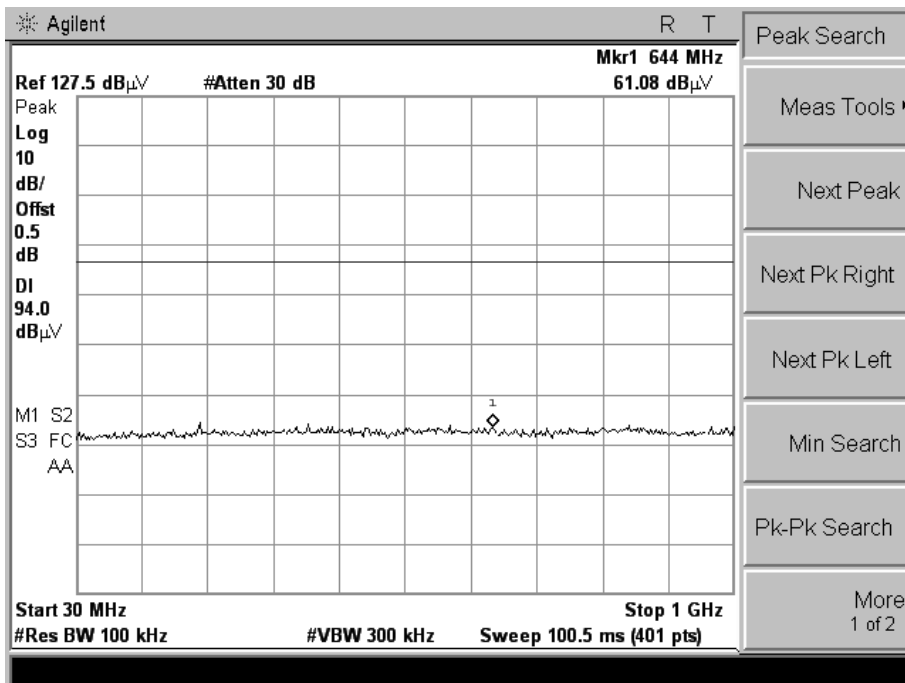

(CH High, 9kHz to 1GHz)

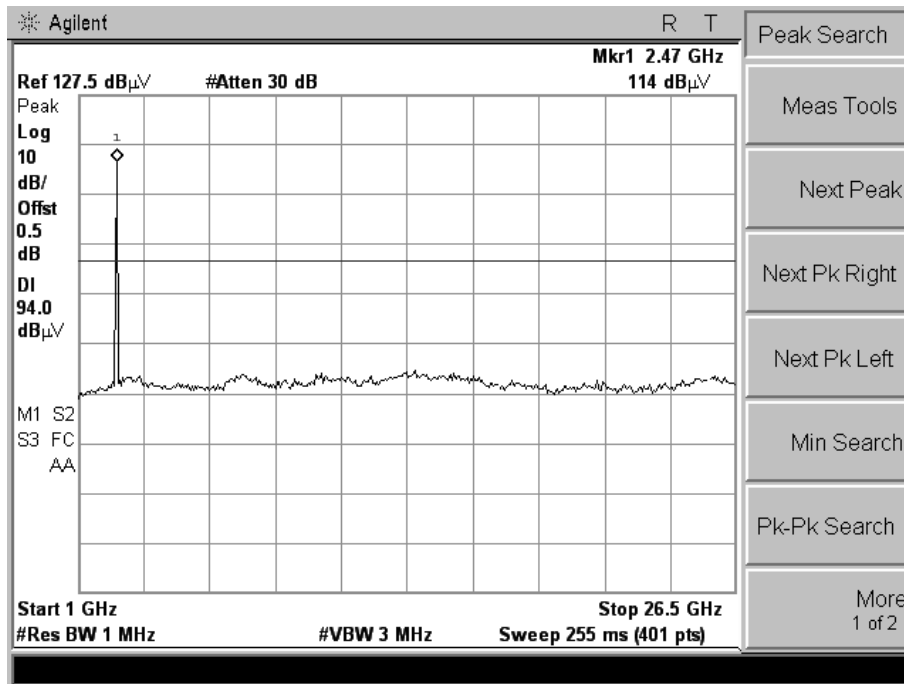

(CH High, 1GHz to 26.5GHz)

### 5.3.3. 802.11n Test Mode (40MHz)

Test Plot:

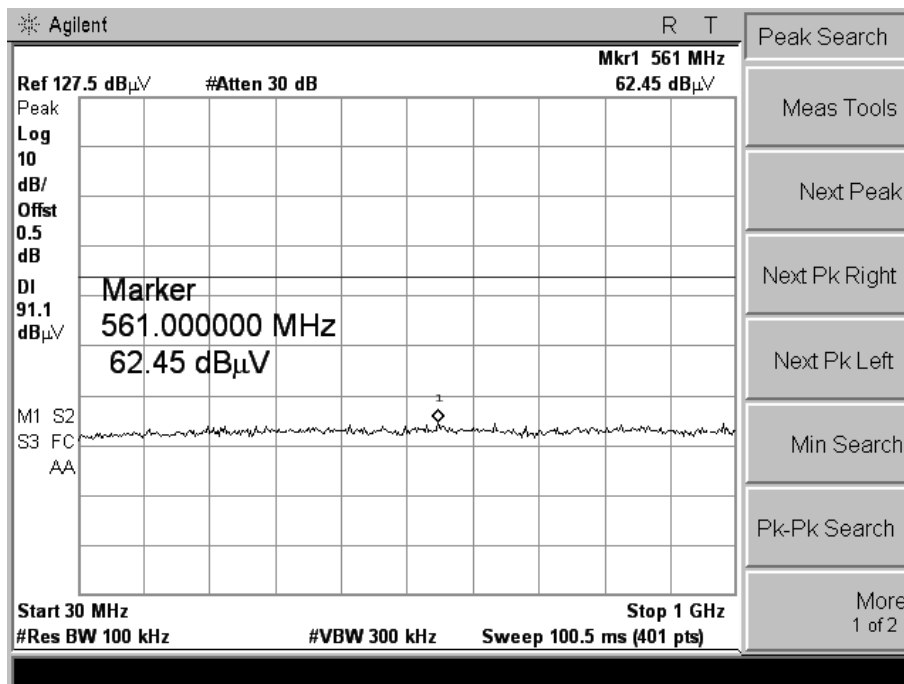

(CH Low, 9kHz to 1GHz)

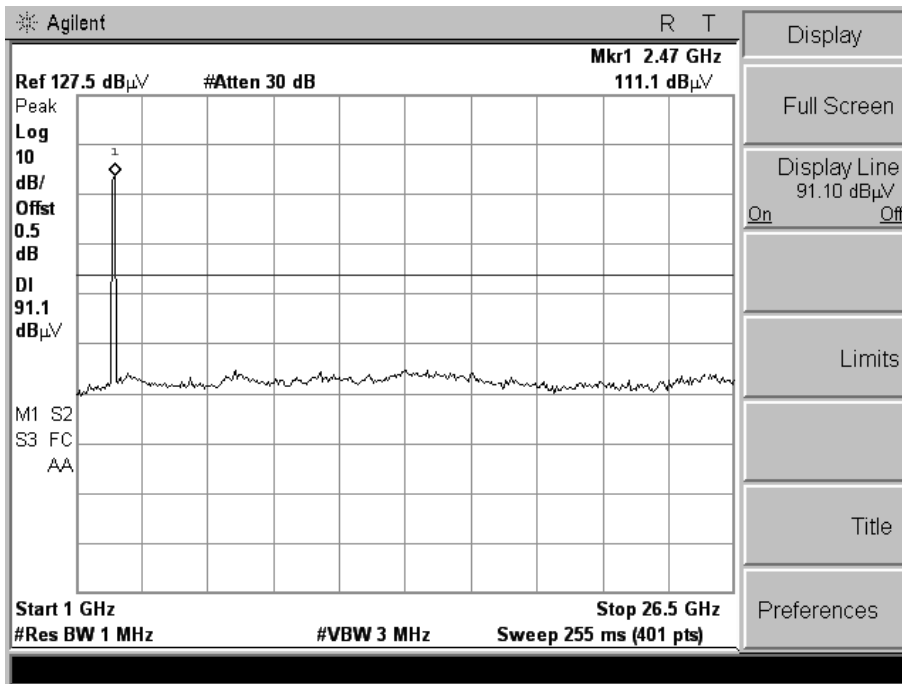

(CH Low, 1GHz to 26.5GHz)

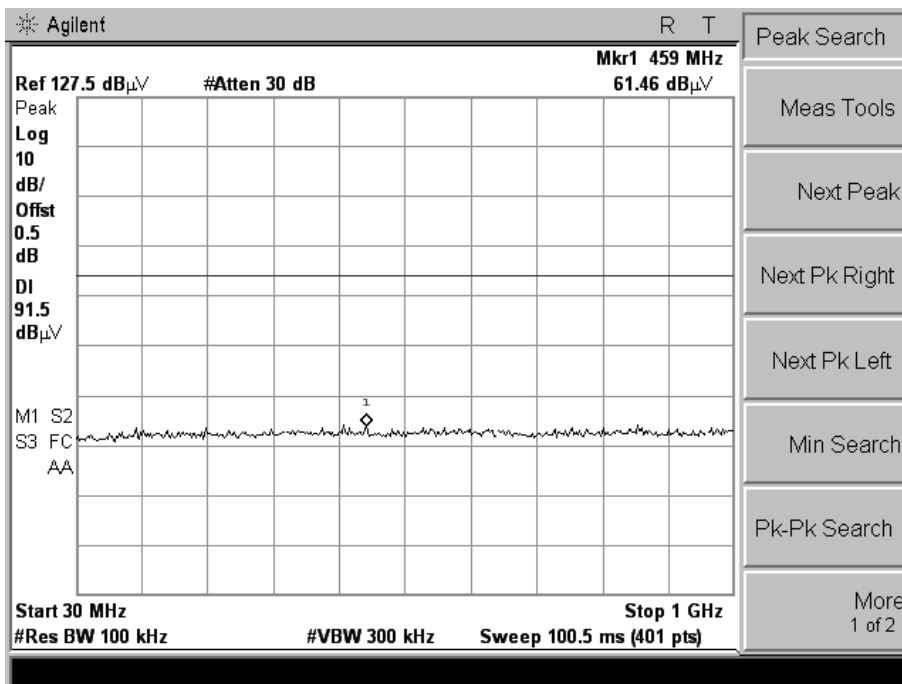

(CH Mid, 9kHz to 1GHz)

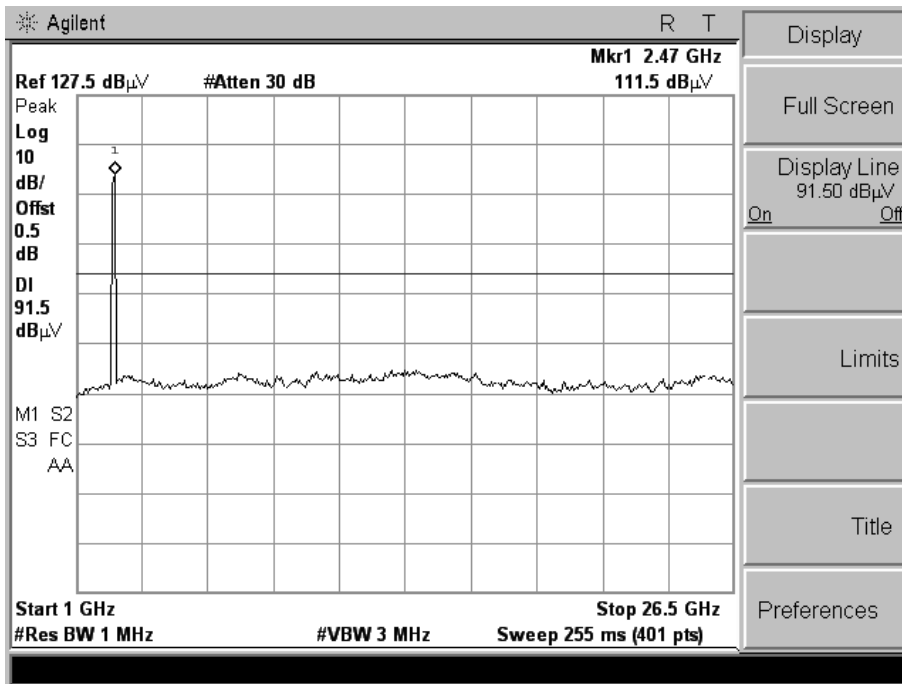

(CH Mid, 1GHz to 26.5GHz)

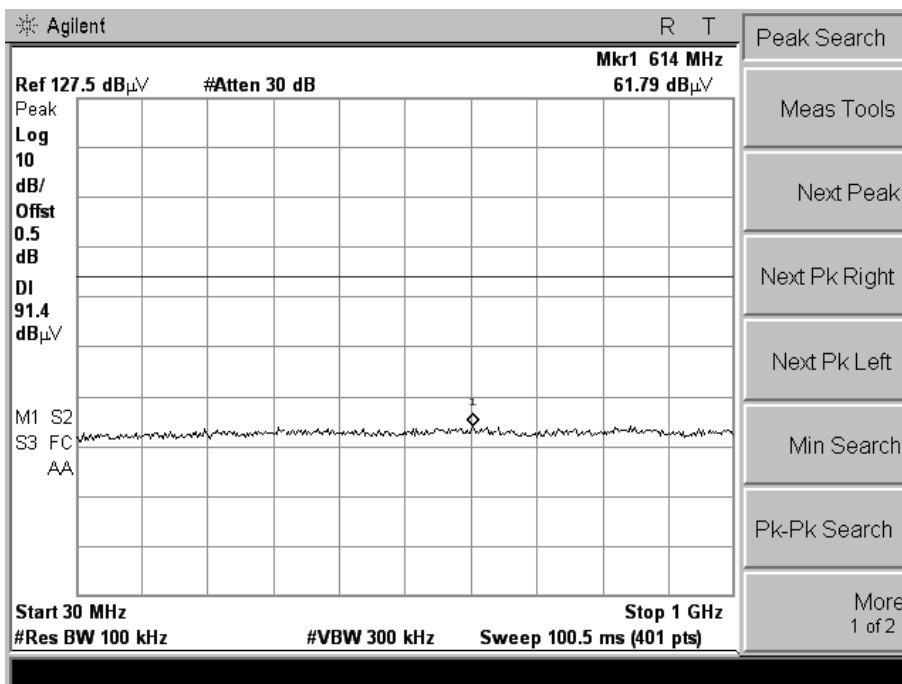

(CH High, 9kHz to 1GHz)

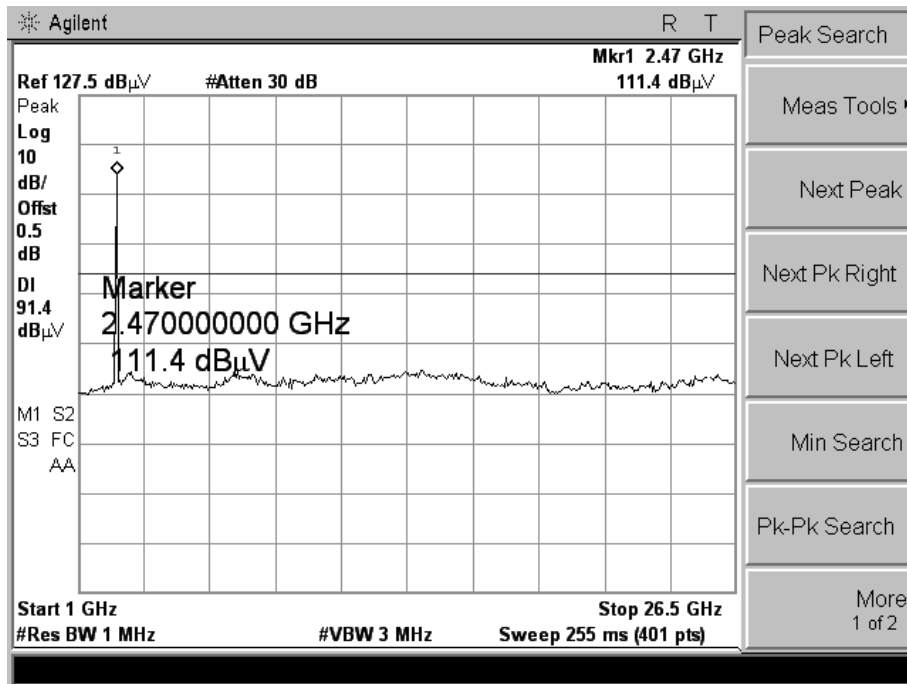

(CH High, 1GHz to 26.5GHz)



## 5.4 Band Edge

### 5.4.1 Definition

In any 100 kHz bandwidth outside the frequency band in which the spread spectrum or digitally modulated intentional radiator is operating, the radio frequency power that is produced by the intentional radiator shall be at least 20 dB below that in the 100 kHz bandwidth within the band that contains the highest level of the desired power, based on either an RF conducted or a radiated measurement, provided the transmitter demonstrates compliance with the peak conducted power limits.

### 5.4.2 Test Description

Spectrum Parameters	Setting
Attenuation	Auto
Start-stop frequency	2350MHz-2420MHz/2450MHz-2500
RB	1MHz
VB	3MHz
Detector	Peak
Trace	Max Hold
Sweep Time	Auto

### 5.4.3 Test Configuration

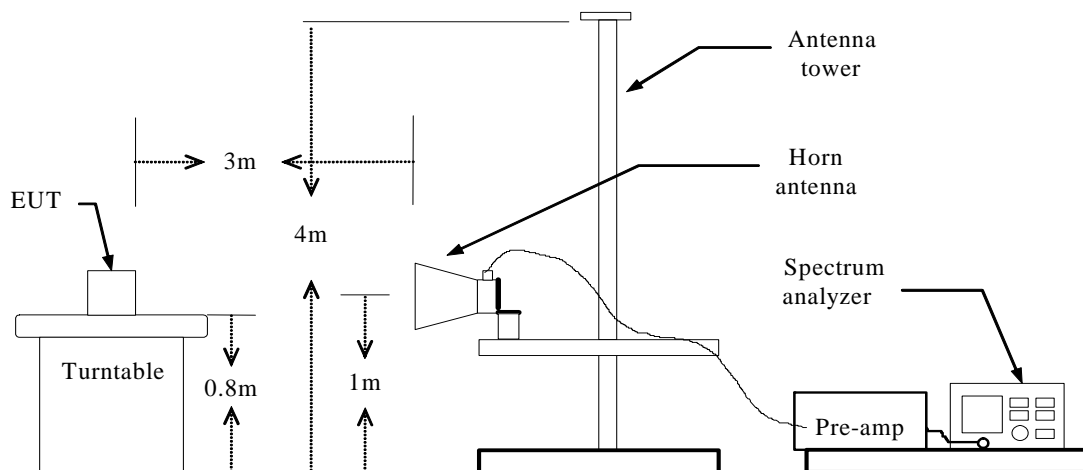

### 5.4.4 Test Result

The EUT operates at continuous transmit test mode. The lowest and highest channels are tested to verify the band edge emissions.



Address: No. 5, Langshan 2nd Rd., North Hi-Tech Industrial park  
 Guangdong, China  
 Tel: 0755-86170306 Fax: 0755-86170310

**Radiated Emission Measurement**

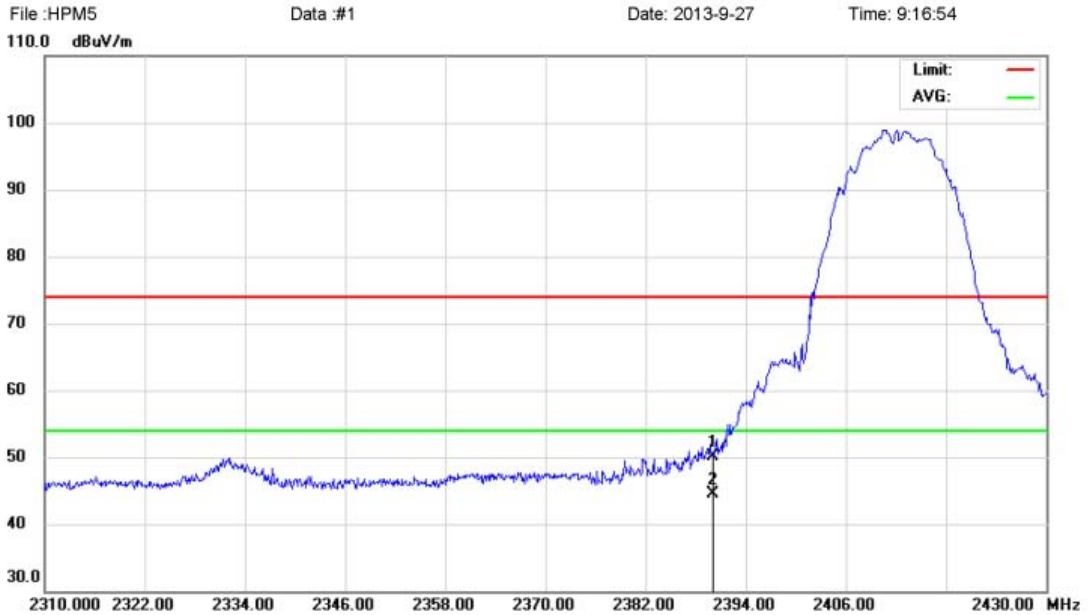

Site Chamber #1      Polarization: **Horizontal**      Temperature: 26  
 Limit: FCC Part15 B Spurious Radiation(PEAK)      Power: DC 12V Adapter AC 120V/60Hz      Humidity: 61 %  
 EUT: Full HD Cloudio TV Set-Top Box      Distance:  
 M/N: HPM5  
 Mode: Lowest Channel Power  
 Note: B

No.	Mk.	Freq.	Reading Level	Correct Factor	Measurement	Limit	Over	Antenna Height	Table Degree	
		MHz	dBuV	dB	dBuV/m	dBuV/m	dB	cm	degree	Comment
1		2390.000	39.68	10.36	50.04	74.00	-23.96	peak		
2	*	2390.000	34.23	10.36	44.59	54.00	-9.41	AVG		

\*:Maximum data    x:Over limit    !:over margin

Engineer Signature: ROY



Address: No. 5, Langshan 2nd Rd., North Hi-Tech Industrial park  
Guangdong, China  
Tel: 0755-86170306 Fax: 0755-86170310

**Radiated Emission Measurement**

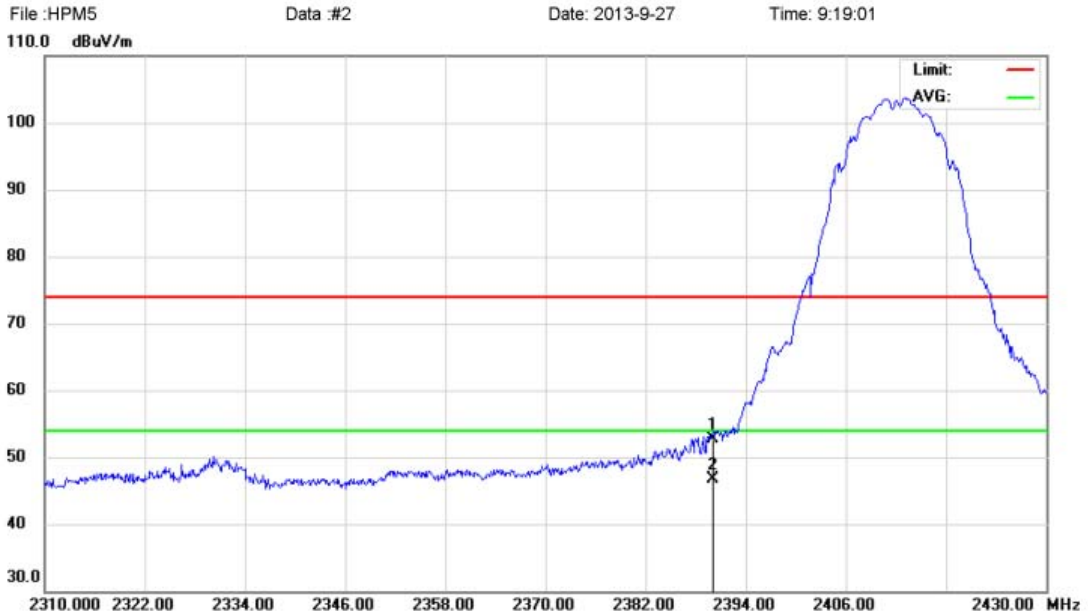

Site Chamber #1 Polarization: **Vertical** Temperature: 26  
 Limit: FCC Part15 B Spurious Radiation(PEAK) Power: DC 12V Adapter AC 120V/60Hz Humidity: 61 %  
 EUT: Full HD Cloudio TV Set-Top Box Distance:  
 M/N: HPM5  
 Mode: Lowest Channel Power  
 Note: B

No.	Mk.	Freq.	Reading Level	Correct Factor	Measurement	Limit	Over	Antenna Height	Table Degree	
		MHz	dBuV	dB	dBuV/m	dBuV/m	dB	cm	degree	Comment
1		2390.000	42.33	10.36	52.69	74.00	-21.31	peak		
2	*	2390.000	36.44	10.36	46.80	54.00	-7.20	AVG		

\*:Maximum data x:Over limit !:over margin

Engineer Signature: ROY



Address: No. 5, Langshan 2nd Rd., North Hi-Tech Industrial park  
 Guangdong, China  
 Tel: 0755-86170306 Fax: 0755-86170310

**Radiated Emission Measurement**

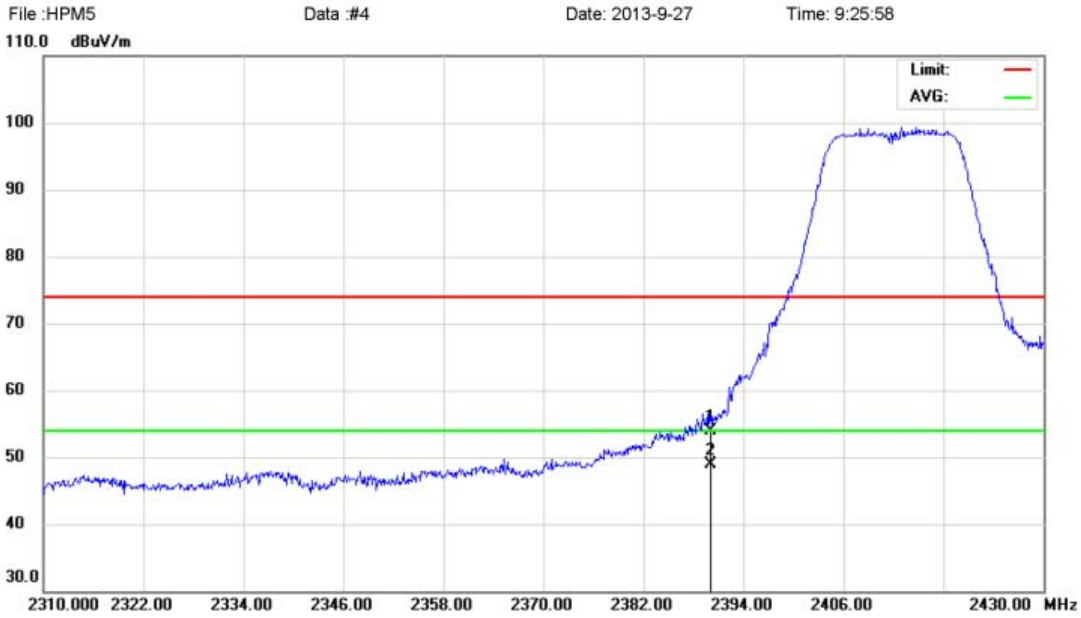

Site Chamber #1 Polarization: **Horizontal** Temperature: 26  
 Limit: FCC Part15 B Spurious Radiation(PEAK) Power: DC 12V Adapter AC 120V/60Hz Humidity: 61 %  
 EUT: Full HD Cloudio TV Set-Top Box Distance:  
 M/N: HPM5  
 Mode: Lowest Channel Power  
 Note: G

No.	Mk.	Freq.	Reading Level	Correct Factor	Measurement	Limit	Over	Antenna Height	Table Degree	
		MHz	dBuV	dB	dBuV/m	dBuV/m	dB	cm	degree	Comment
1		2390.000	43.49	10.36	53.85	74.00	-20.15	peak		
2	*	2390.000	38.46	10.36	48.82	54.00	-5.18	AVG		

\*:Maximum data x:Over limit !:over margin

Engineer Signature:ROY



Address: No. 5, Langshan 2nd Rd., North Hi-Tech Industrial park  
 Guangdong, China  
 Tel: 0755-86170306 Fax: 0755-86170310

**Radiated Emission Measurement**

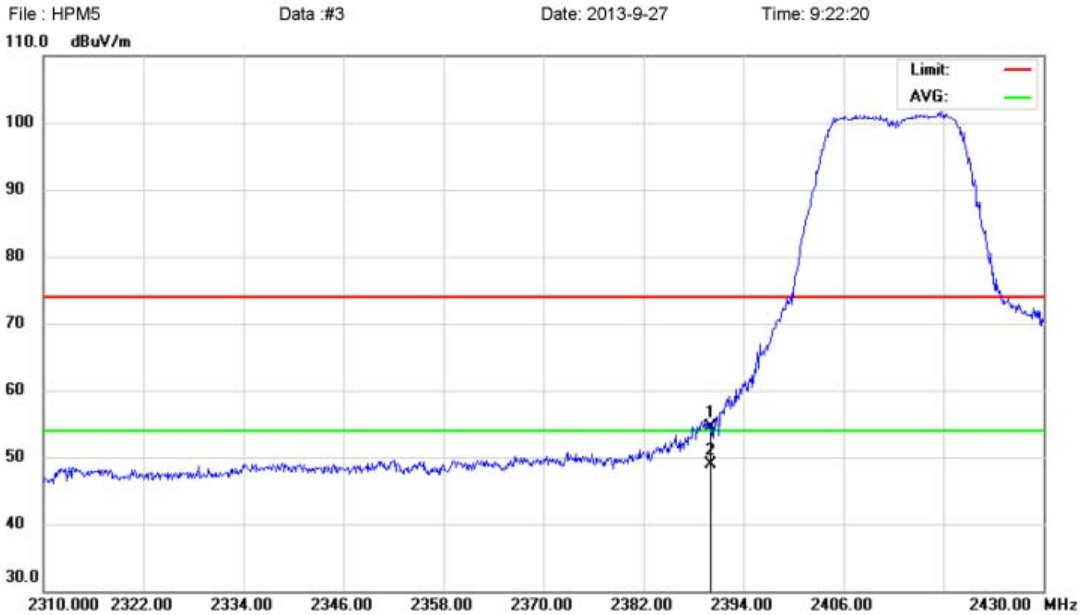

Site Chamber #1 Polarization: **Vertical** Temperature: 26  
 Limit: FCC Part15 B Spurious Radiation(PEAK) Power: DC 12V Adapter AC 120V/60Hz Humidity: 61 %  
 EUT: Full HD Cloudio TV Set-Top Box Distance:  
 M/N: HPM5  
 Mode: Lowest Channel Power  
 Note: G

No.	Mk.	Freq.	Reading Level	Correct Factor	Measurement	Limit	Over	Antenna Height	Table Degree	
		MHz	dBuV	dB	dBuV/m	dBuV/m	dB	cm	degree	Comment
1		2390.000	44.19	10.36	54.55	74.00	-19.45	peak		
2	*	2390.000	38.52	10.36	48.88	54.00	-5.12	AVG		

\*:Maximum data x:Over limit !:over margin

Engineer Signature: ROY



Address: No. 5, Langshan 2nd Rd., North Hi-Tech Industrial park  
 Guangdong, China  
 Tel: 0755-86170306 Fax: 0755-86170310

**Radiated Emission Measurement**

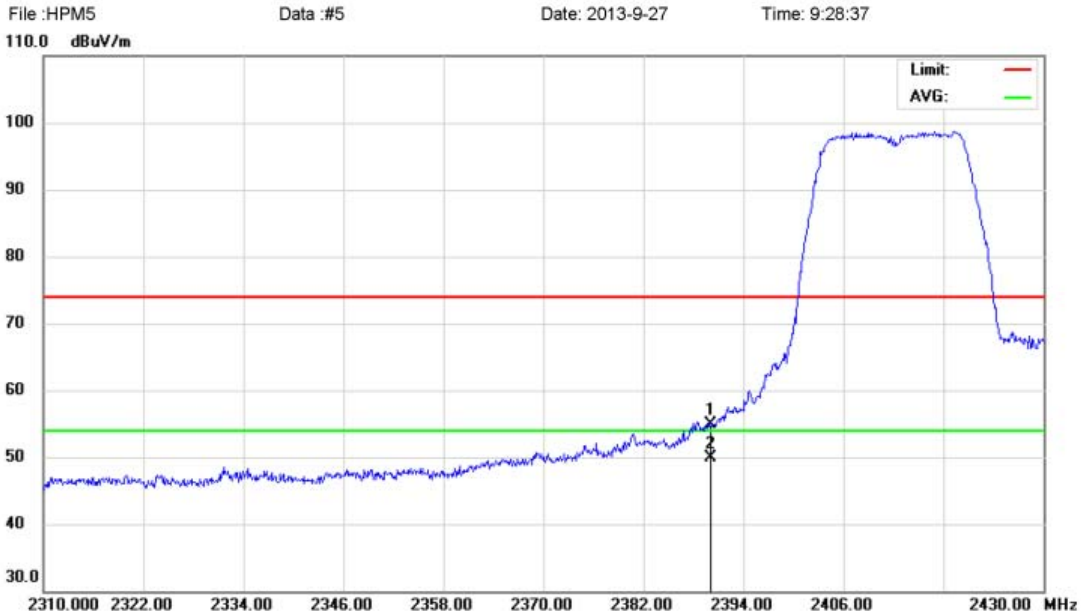

Site Chamber #1      Polarization: **Horizontal**      Temperature: 26  
 Limit: FCC Part15 B Spurious Radiation(PEAK)      Power: DC 12V Adapter AC 120V/60Hz      Humidity: 61 %  
 EUT: Full HD Cloudio TV Set-Top Box      Distance:  
 M/N: HPM5  
 Mode: Lowest Channel Power  
 Note: N20

No.	Mk.	Freq.	Reading Level	Correct Factor	Measurement	Limit	Over	Antenna Height	Table Degree	
		MHz	dBuV	dB	dBuV/m	dBuV/m	dB	cm	degree	Comment
1		2390.000	44.62	10.36	54.98	74.00	-19.02	peak		
2	*	2390.000	39.51	10.36	49.87	54.00	-4.13	AVG		

\*:Maximum data    x:Over limit    !:over margin

Engineer Signature: ROY



Address: No. 5, Langshan 2nd Rd., North Hi-Tech Industrial park  
 Guangdong, China  
 Tel: 0755-86170306 Fax: 0755-86170310

**Radiated Emission Measurement**

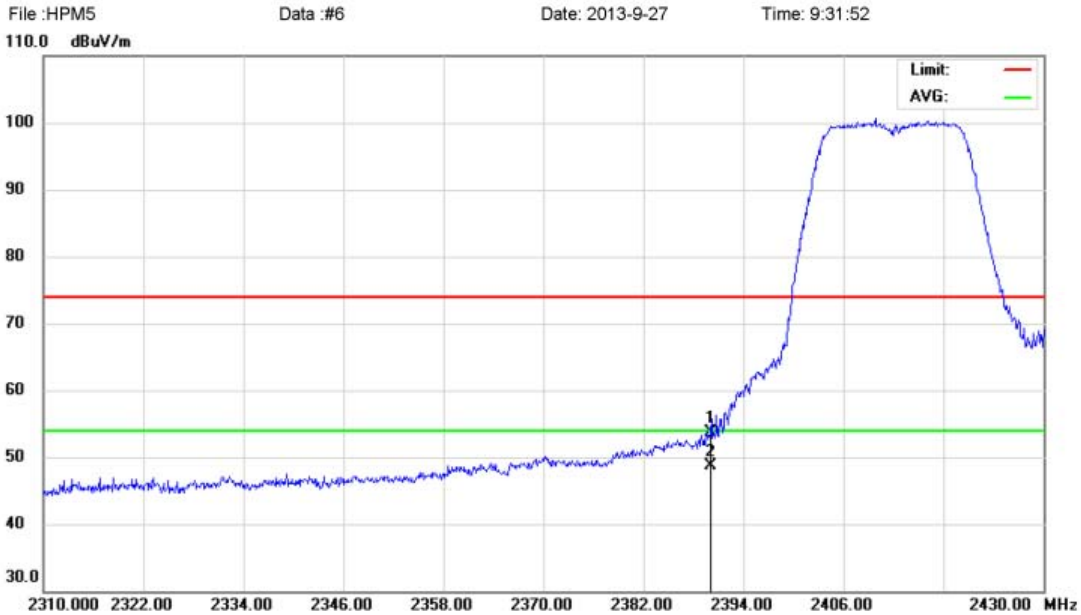

Site Chamber #1 Polarization: **Vertical** Temperature: 26  
 Limit: FCC Part15 B Spurious Radiation(PEAK) Power: DC 12V Adapter AC 120V/60Hz Humidity: 61 %  
 EUT: Full HD Cloudio TV Set-Top Box Distance:  
 M/N: HPM5  
 Mode: Lowest Channel Power  
 Note: N20

No.	Mk.	Freq.	Reading Level	Correct Factor	Measurement	Limit	Over	Antenna Height	Table Degree	
		MHz	dBuV	dB	dBuV/m	dBuV/m	dB	cm	degree	Comment
1		2390.000	43.29	10.36	53.65	74.00	-20.35	peak		
2	*	2390.000	38.26	10.36	48.62	54.00	-5.38	AVG		

\*:Maximum data x:Over limit !:over margin

Engineer Signature: ROY



Address: No.5, Langshan 2nd Rd., North Hi-Tech Industrial park  
 Guangdong, China  
 Tel: 0755-86170306 Fax: 0755-86170310

**Radiated Emission Measurement**

File : HPM5      Data : #8      Date : 2013-9-27      Time : 9:39:19

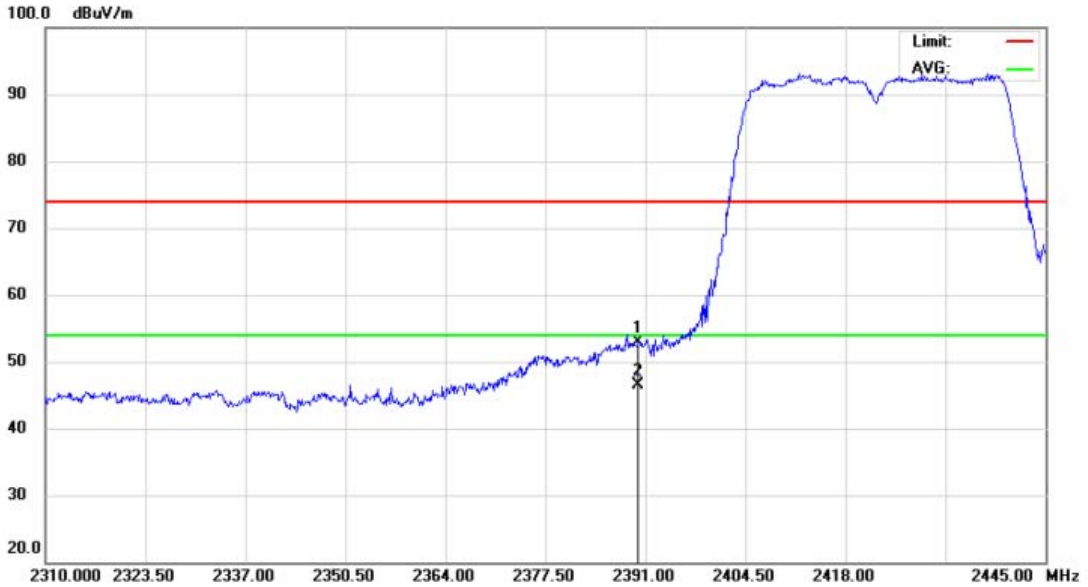

Site Chamber #1      Polarization: **Horizontal**      Temperature: 26  
 Limit: FCC Part15 B Spurious Radiation(PEAK)      Power: DC 12V Adapter AC 120V/60Hz      Humidity: 61 %  
 EUT: Full HD Cloudio TV Set-Top Box      Distance:  
 M/N: HPM5  
 Mode: Lowest Channel Power  
 Note: N40

No.	Mk.	Freq.	Reading Level	Correct Factor	Measurement	Limit	Over	Antenna Height	Table Degree	
		MHz	dBuV	dB	dBuV/m	dBuV/m	dB	cm	degree	Comment
1	*	2390.000	42.46	10.36	52.82	74.00	-21.18	peak		
2		2390.000	36.16	10.36	46.52	74.00	-27.48	peak		

\*:Maximum data    x:Over limit    !:over margin

Engineer Signature: ROY





Address: No.5, Langshan 2nd Rd., North Hi-Tech Industrial park  
 Guangdong, China  
 Tel: 0755-86170306 Fax: 0755-86170310

**Radiated Emission Measurement**

File : HPM5                      Data : #7                      Date: 2013-9-27                      Time: 9:35:01

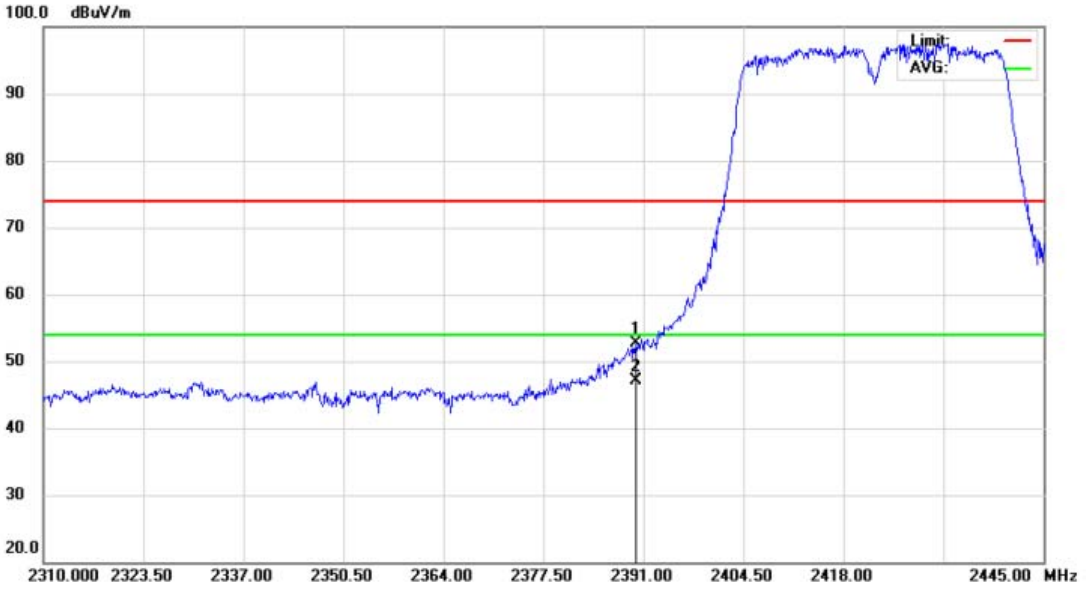

Site Chamber #1                      Polarization: **Vertical**                      Temperature: 26  
 Limit: FCC Part15 B Spurious Radiation(PEAK)                      Power: DC 12V Adapter AC 120V/60Hz                      Humidity: 61 %  
 EUT: Full HD Cloudio TV Set-Top Box                      Distance:  
 M/N: HPM5  
 Mode: Lowest Channel Power  
 Note: N40

No.	Mk.	Freq.	Reading Level	Correct Factor	Measurement	Limit	Over	Antenna Height	Table Degree	
		MHz	dBuV	dB	dBuV/m	dBuV/m	dB	cm	degree	Comment
1		2390.000	42.34	10.36	52.70	74.00	-21.30	peak		
2	*	2390.000	36.82	10.36	47.18	54.00	-6.82	AVG		

\*:Maximum data    x:Over limit    !:over margin

Engineer Signature: ROY



Address: No. 5, Langshan 2nd Rd., North Hi-Tech Industrial park  
 Guangdong, China  
 Tel: 0755-86170306 Fax: 0755-86170310

**Radiated Emission Measurement**

File : HPM5      Data : #9      Date: 2013-9-27      Time: 9:43:53



Site Chamber #1      Polarization: **Horizontal**      Temperature: 26  
 Limit: FCC Part15 B Spurious Radiation(PEAK)      Power: DC 12V Adapter AC 120V/60Hz      Humidity: 61 %  
 EUT: Full HD Cloudio TV Set-Top Box      Distance:  
 M/N: HPM5  
 Mode: Highest Channel Power  
 Note: N40

No.	Mk.	Freq.	Reading Level	Correct Factor	Measurement	Limit	Over	Antenna Height	Table Degree	
		MHz	dBuV	dB	dBuV/m	dBuV/m	dB	cm	degree	Comment
1		2483.500	43.15	10.73	53.88	74.00	-20.12	peak		
2	*	2483.500	38.15	10.73	48.88	54.00	-5.12	AVG		

\*:Maximum data    x:Over limit    !:over margin

Engineer Signature: ROY



Address: No.5, Langshan 2nd Rd., North Hi-Tech Industrial park  
 Guangdong, China  
 Tel: 0755-86170306 Fax: 0755-86170310

**Radiated Emission Measurement**

File : HPM5      Data : #10      Date: 2013-9-27      Time: 9:47:08

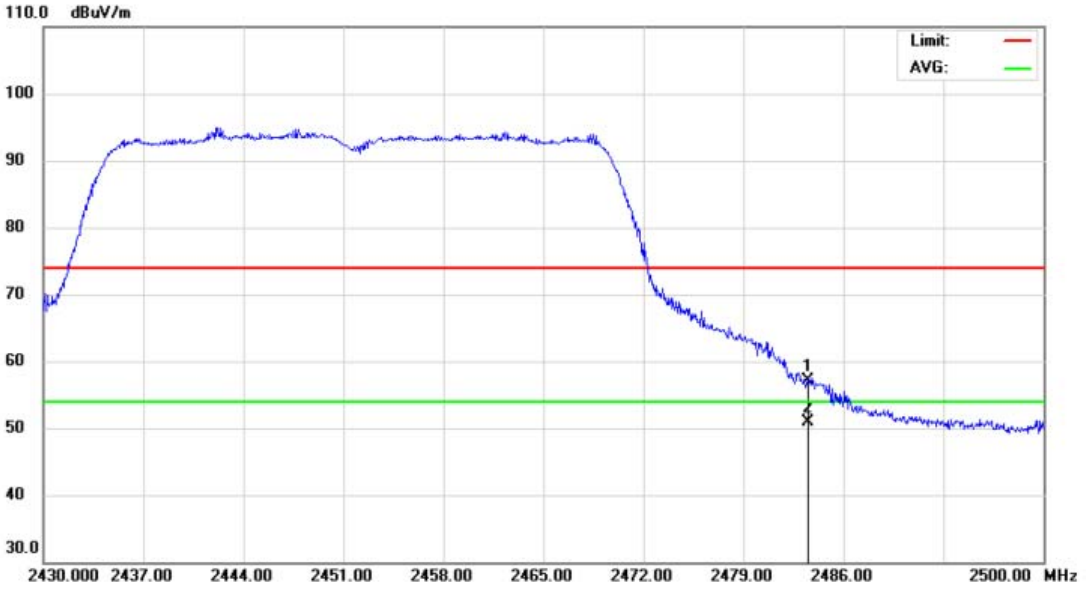

Site Chamber #1      Polarization: **Vertical**      Temperature: 26  
 Limit: FCC Part15 B Spurious Radiation(PEAK)      Power: DC 12V Adapter AC 120V/60Hz      Humidity: 61 %  
 EUT: Full HD Cloudio TV Set-Top Box      Distance:  
 M/N: HPM5  
 Mode: Highest Channel Power  
 Note: N40

No.	Mk.	Freq.	Reading Level	Correct Factor	Measurement	Limit	Over	Antenna Height	Table Degree	
		MHz	dBuV	dB	dBuV/m	dBuV/m	dB	cm	degree	Comment
1		2483.500	46.44	10.73	57.17	74.00	-16.83			peak
2	*	2483.500	40.09	10.73	50.82	54.00	-3.18			AVG

\*:Maximum data    x:Over limit    !:over margin

Engineer Signature: ROY



Address: No.5, Langshan 2nd Rd., North Hi-Tech Industrial park  
 Guangdong, China  
 Tel: 0755-86170306 Fax: 0755-86170310

**Radiated Emission Measurement**

File : HPM5      Data : #12      Date : 2013-9-27      Time : 9:54:46  
 110.0 dBuV/m

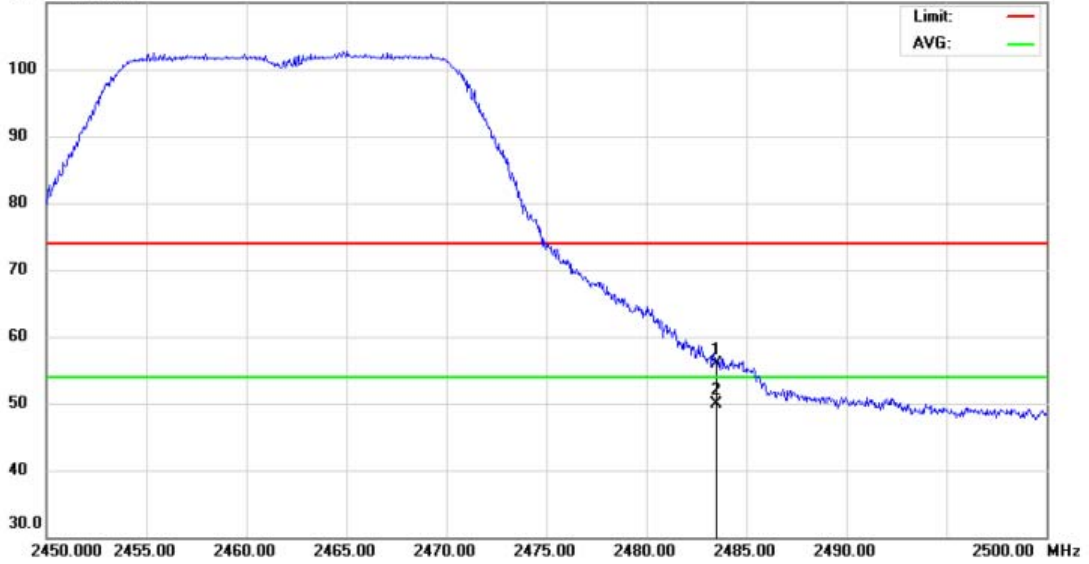

Site Chamber #1      Polarization: **Horizontal**      Temperature: 26  
 Limit: FCC Part15 B Spurious Radiation(PEAK)      Power: DC 12V Adapter AC 120V/60Hz      Humidity: 61 %  
 EUT: Full HD Cloudio TV Set-Top Box      Distance:  
 M/N: HPM5  
 Mode: Highest Channel Power  
 Note: N20

No.	Mk.	Freq.	Reading Level	Correct Factor	Measurement	Limit	Over	Antenna Height	Table Degree	
		MHz	dBuV	dB	dBuV/m	dBuV/m	dB	cm	degree	Comment
1		2483.500	45.20	10.73	55.93	74.00	-18.07	peak		
2	*	2483.500	39.21	10.73	49.94	54.00	-4.06	AVG		

\*:Maximum data    x:Over limit    !:over margin

Engineer Signature: ROY



Address: No.5, Langshan 2nd Rd., North Hi-Tech Industrial park  
 Guangdong, China  
 Tel: 0755-86170306 Fax: 0755-86170310

**Radiated Emission Measurement**

File : HPM5      Data : #11      Date: 2013-9-27      Time: 9:51:45  
 110.0 dBuV/m

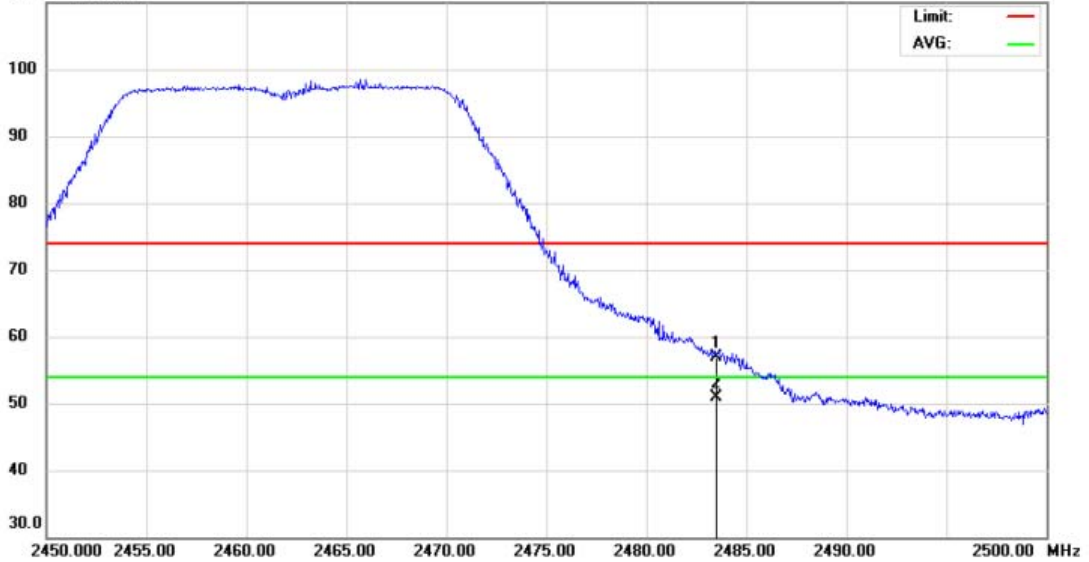

Site Chamber #1      Polarization: **Vertical**      Temperature: 26  
 Limit: FCC Part15 B Spurious Radiation(PEAK)      Power: DC 12V Adapter AC 120V/60Hz      Humidity: 61 %  
 EUT: Full HD Cloudio TV Set-Top Box      Distance:  
 M/N: HPM5  
 Mode: Highest Channel Power  
 Note: N20

No.	Mk.	Freq.	Reading Level	Correct Factor	Measurement	Limit	Over	Antenna Height	Table Degree	
		MHz	dBuV	dB	dBuV/m	dBuV/m	dB	cm	degree	Comment
1	*	2483.500	46.25	10.73	56.98	74.00	-17.02	peak		
2		2483.500	40.25	10.73	50.98	74.00	-23.02	QP		

\*:Maximum data    x:Over limit    !:over margin

Engineer Signature:



Address: No.5, Langshan 2nd Rd., North Hi-Tech Industrial park  
 Guangdong, China  
 Tel: 0755-86170306 Fax: 0755-86170310

**Radiated Emission Measurement**

File : HPM5      Data : #13      Date: 2013-9-27      Time: 9:59:55

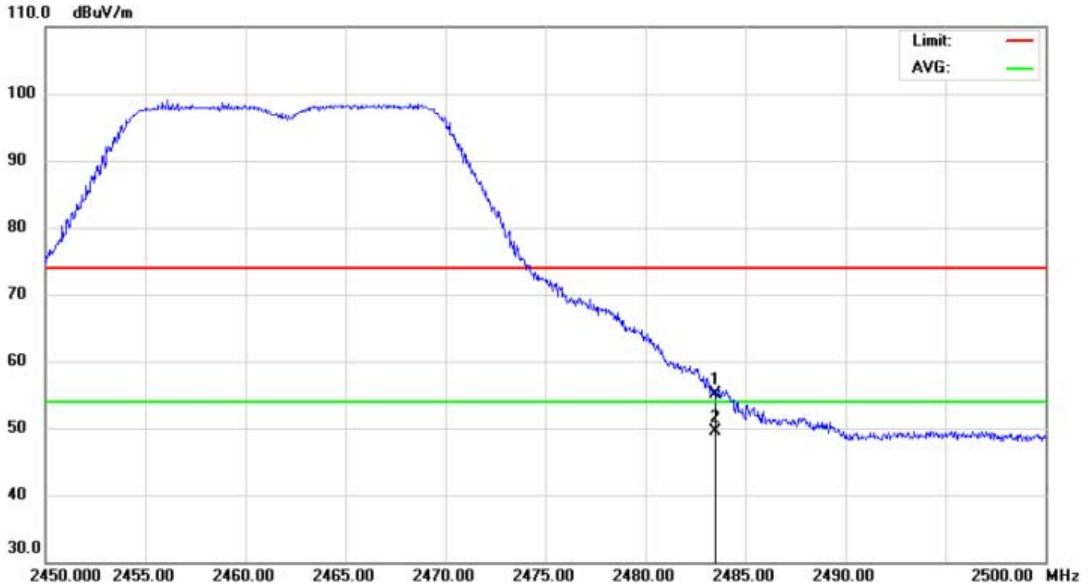

Site Chamber #1      Polarization: **Horizontal**      Temperature: 26  
 Limit: FCC Part15 B Spurious Radiation(PEAK)      Power: DC 12V Adapter AC 120V/60Hz      Humidity: 61 %  
 EUT: Full HD Cloudio TV Set-Top Box      Distance:  
 M/N: HPM5  
 Mode: Highest Channel Power  
 Note: G

No.	Mk.	Freq.	Reading Level	Correct Factor	Measurement	Limit	Over	Antenna Height	Table Degree	
		MHz	dBuV	dB	dBuV/m	dBuV/m	dB	cm	degree	Comment
1		2483.500	44.30	10.73	55.03	74.00	-18.97	peak		
2	*	2483.500	38.75	10.73	49.48	54.00	-4.52	AVG		

\*:Maximum data    x:Over limit    !:over margin

Engineer Signature: ROY



Address: No.5, Langshan 2nd Rd., North Hi-Tech Industrial park  
 Guangdong, China  
 Tel: 0755-86170306 Fax: 0755-86170310

**Radiated Emission Measurement**

File : HPM5      Data : #14      Date: 2013-9-27      Time: 10:03:59  
 110.0 dBuV/m

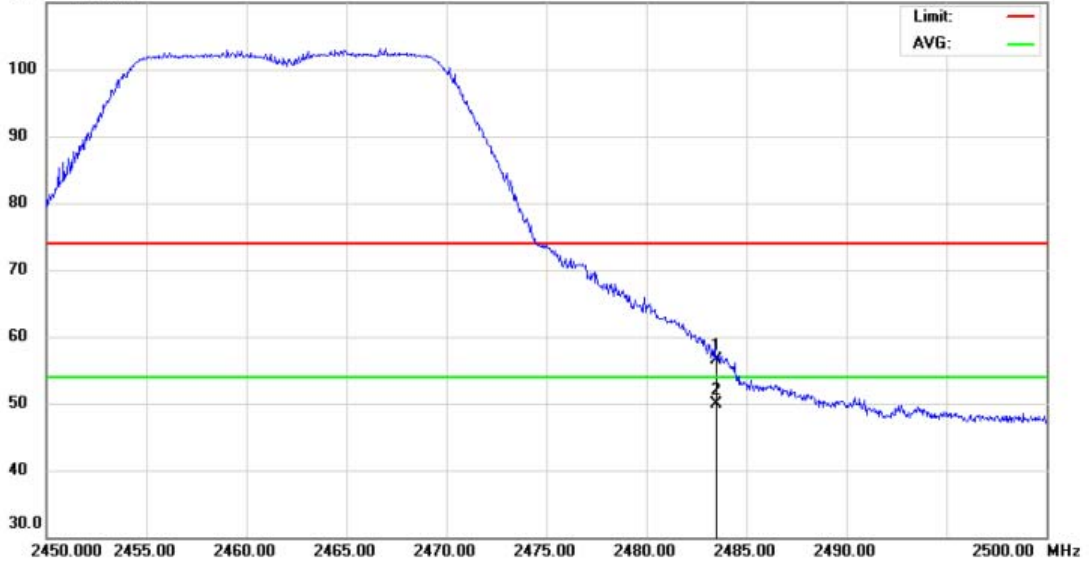

Site Chamber #1      Polarization: **Vertical**      Temperature: 26  
 Limit: FCC Part15 B Spurious Radiation(PEAK)      Power: DC 12V Adapter AC 120V/60Hz      Humidity: 61 %  
 EUT: Full HD Cloudio TV Set-Top Box      Distance:  
 M/N: HPM5  
 Mode: Highest Channel Power  
 Note: G

No.	Mk.	Freq.	Reading Level	Correct Factor	Measurement	Limit	Over	Antenna Height	Table Degree
		MHz	dBuV	dB	dBuV/m	dBuV/m	dB	cm	degree
1		2483.500	45.85	10.73	56.58	74.00	-17.42	peak	
2	*	2483.500	39.11	10.73	49.84	54.00	-4.16	AVG	

\*:Maximum data    x:Over limit    !:over margin

Engineer Signature: ROY





Address: No.5, Langshan 2nd Rd., North Hi-Tech Industrial park  
 Guangdong, China  
 Tel: 0755-86170306 Fax: 0755-86170310

**Radiated Emission Measurement**

File : HPM5      Data : #16      Date: 2013-9-27      Time: 10:11:54

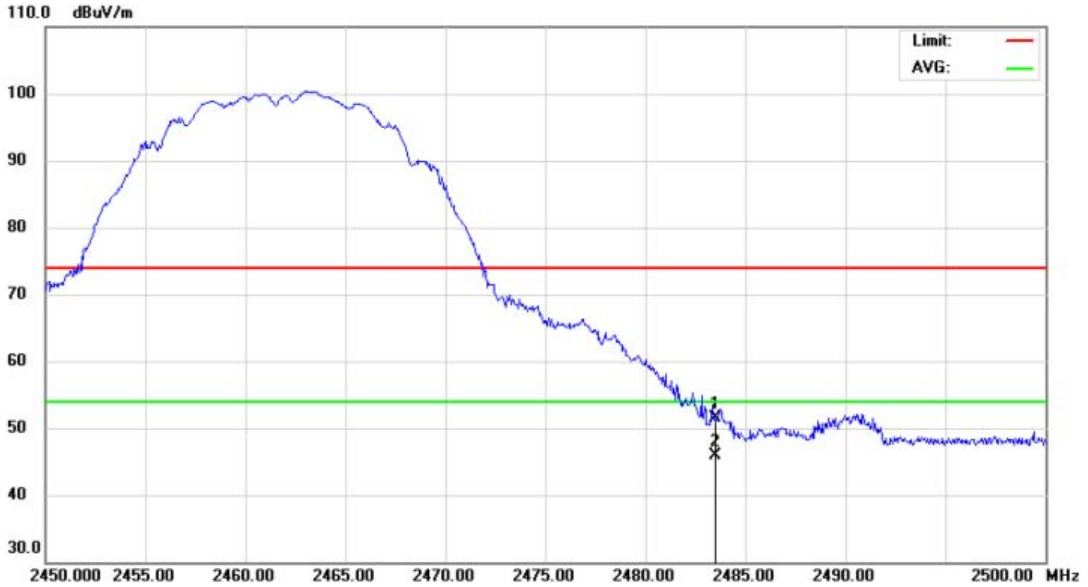

Site Chamber #1      Polarization: **Horizontal**      Temperature: 26  
 Limit: FCC Part15 B Spurious Radiation(PEAK)      Power: DC 12V Adapter AC 120V/60Hz      Humidity: 61 %  
 EUT: Full HD Cloudio TV Set-Top Box      Distance:  
 M/N: HPM5  
 Mode: Highest Channel Power  
 Note: B

No.	Mk.	Freq.	Reading Level	Correct Factor	Measurement	Limit	Over	Antenna Height	Table Degree		
		MHz	dBuV	dB	dBuV/m	dBuV/m	dB	Detector	cm	degree	Comment
1		2483.500	40.71	10.73	51.44	74.00	-22.56	peak			
2	*	2483.500	35.23	10.73	45.96	54.00	-8.04	AVG			

\*:Maximum data    x:Over limit    !:over margin

Engineer Signature: ROY





Address: No.5, Langshan 2nd Rd., North Hi-Tech Industrial park  
 Guangdong, China  
 Tel: 0755-86170306 Fax: 0755-86170310

**Radiated Emission Measurement**

File : HPM5      Data : #15      Date: 2013-9-27      Time: 10:07:58

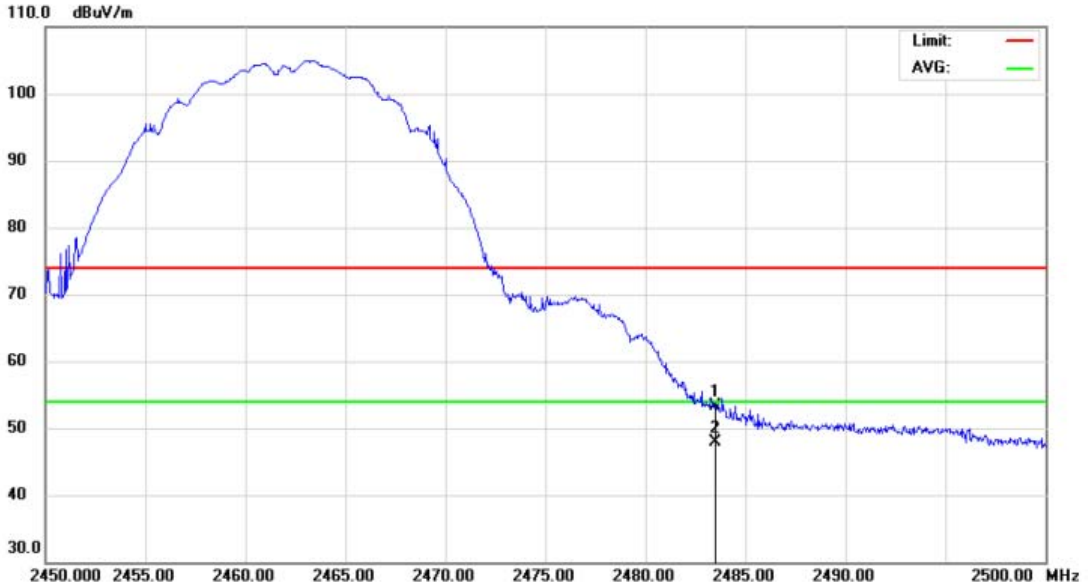

Site Chamber #1      Polarization: **Vertical**      Temperature: 26  
 Limit: FCC Part15 B Spurious Radiation(PEAK)      Power: DC 12V Adapter AC 120V/60Hz      Humidity: 61 %  
 EUT: Full HD Cloudio TV Set-Top Box      Distance:  
 M/N: HPM5  
 Mode: Highest Channel Power  
 Note: B

No.	Mk.	Freq.	Reading Level	Correct Factor	Measurement	Limit	Over	Antenna Height	Table Degree		
		MHz	dBuV	dB	dBuV/m	dBuV/m	dB	Detector	cm	degree	Comment
1		2483.500	42.60	10.73	53.33	74.00	-20.67	peak			
2	*	2483.500	37.23	10.73	47.96	54.00	-6.04	AVG			

\*:Maximum data    x:Over limit    !:over margin

Engineer Signature: ROY

### 5.5 Power Spectral Density (PSD)

#### 5.5.1 Definition

For digitally modulated systems, the power spectral density conducted from the intentional radiator to the antenna shall not be greater than 8 dBm in any 3 kHz band.

#### 5.5.2 Limit

FCC Part15(15.247)				
Section	Test Item	Limit	Frequency Range(MHz)	Result
15.247	Power Spectral Density	8 dBm (in any 3KHz)	2402-2483.5	PASS

#### 5.5.3 Test Configuration

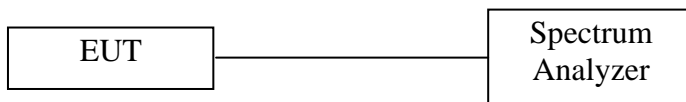

#### 5.5.4 Test Description

Spectrum Parameters	Setting
Attenuation	Auto
Span Frequency	1.5 DTS Bandwidth
RB	3kHz
VB	10KHz
Detector	Peak
Trace	Max Hold
Sweep Time	Auto

- a. Set analyzer center frequency to DTS Channel center frequency.
- b. Set the span to 1.5 times the DTS bandwidth.
- c. Set the RBW to:  $3\text{kHz} \leq \text{RBW} \leq 100\text{kHz}$ .
- d. Set the  $\text{VBW} \geq 3 \times \text{RBW}$ .
- e. Detector=peak.
- f. Sweep time=auto couple.
- g. Trace mode=max hold.
- h. Allow trace to fully stabilize.
- i. Use the peak marker function to determine the maximum amplitude level with the RBW.
- j. If measured value exceeds limit, reduce RBW (no less than 3kHz) and repeat.

#### 5.5.5 Test Configuration

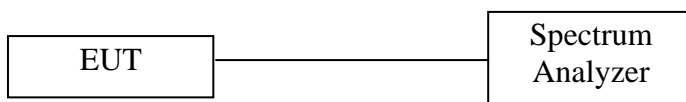

#### 5.5.6 Operation Condition

The EUT tested system was configured as the statements of 2.1 unless otherwise a special operating condition is specified in the follows during the testing.

#### 5.5.7 Test Result

The lowest, middle and highest channels are tested to verify the power spectral density.

### 5.5.6.1 802.11b Test Mode

#### A. Test Verdict:

Channel	Frequency (MHz)	PSD (dBm)	Limits(dBm)	Result
1	2412	-6.653	≤8	PASS
7	2437	-6.195	≤8	PASS
11	2462	-5.589	≤8	PASS

#### B. Test Plot:

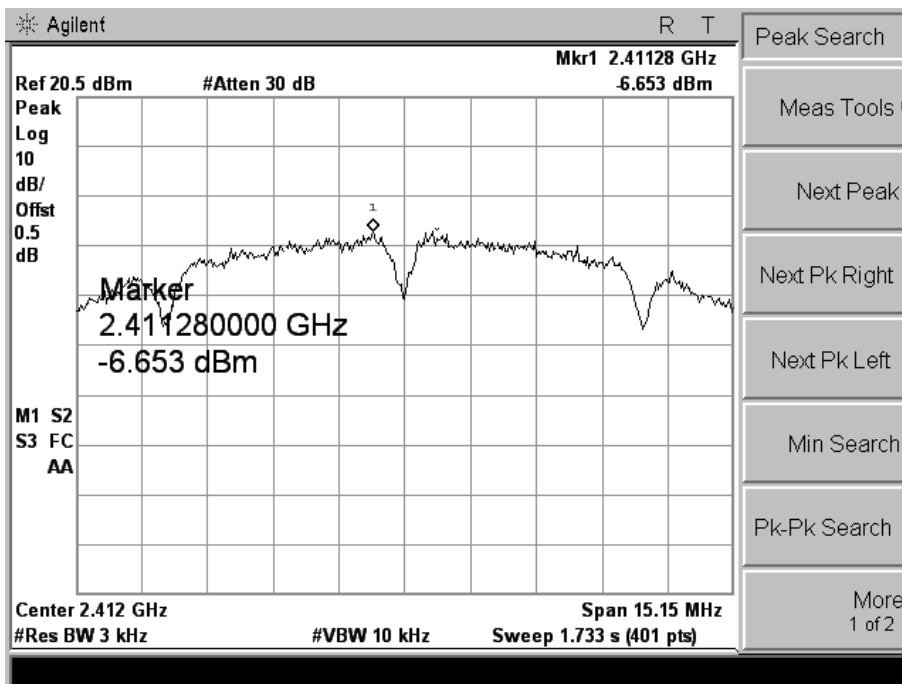

(CH Low)

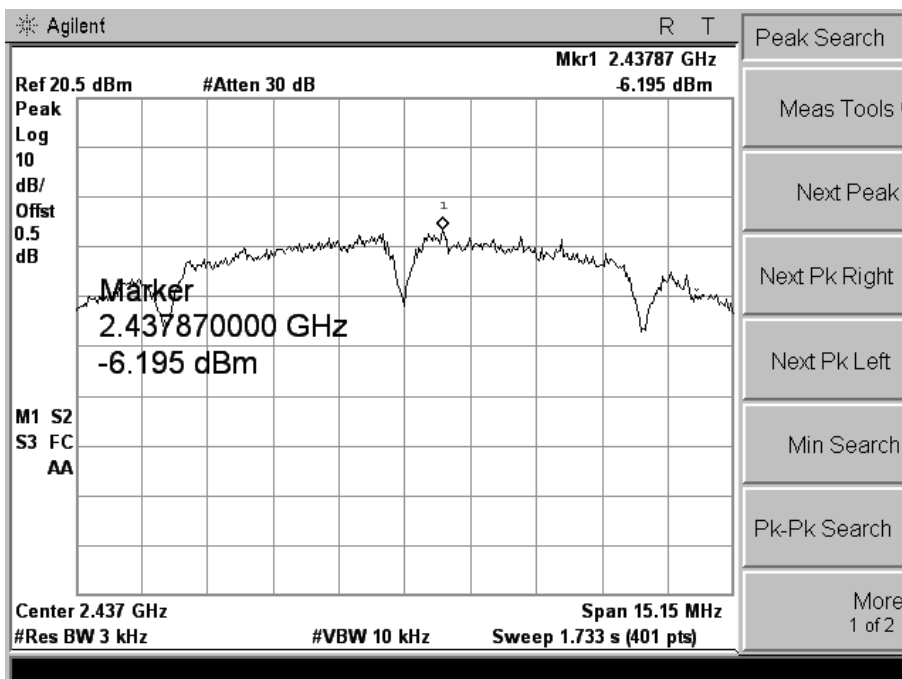

(CH Mid)

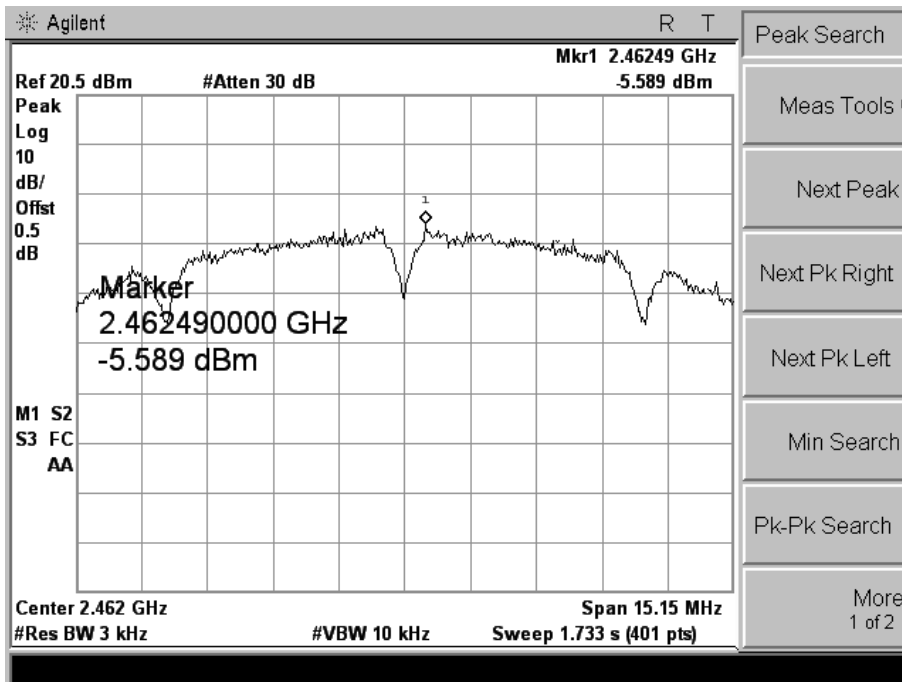

(CH High)

### 5.5.6.2 802.11g Test Mode

#### A. Test Verdict:

Channel	Frequency (MHz)	PSD (dBm)	Limits(dBm)	Result
1	2412	-13.47	≤8	PASS
7	2437	-12.99	≤8	PASS
11	2462	-13.23	≤8	PASS

#### B. Test Plot:

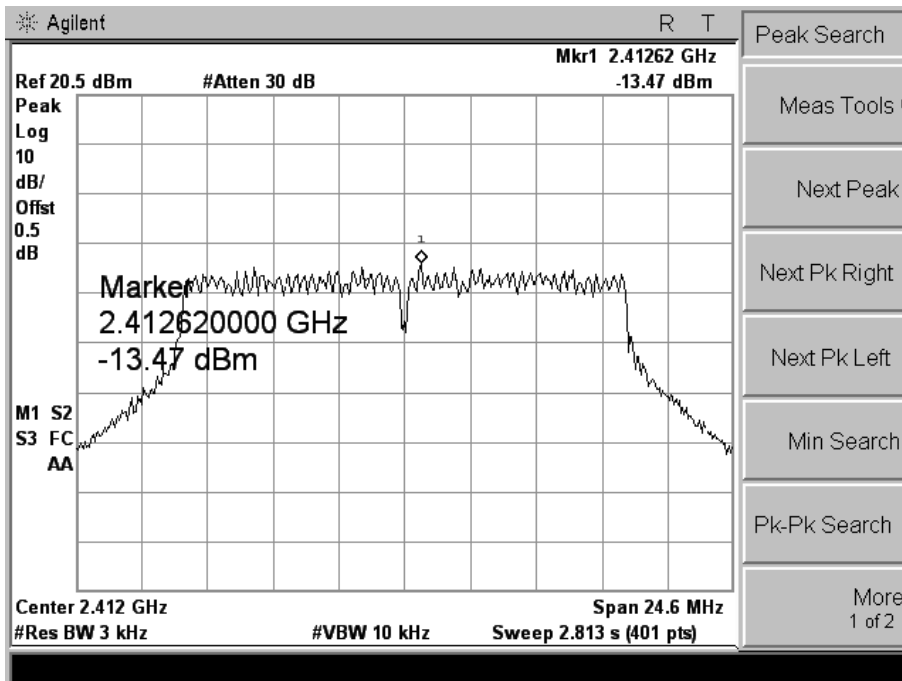

(CH Low)

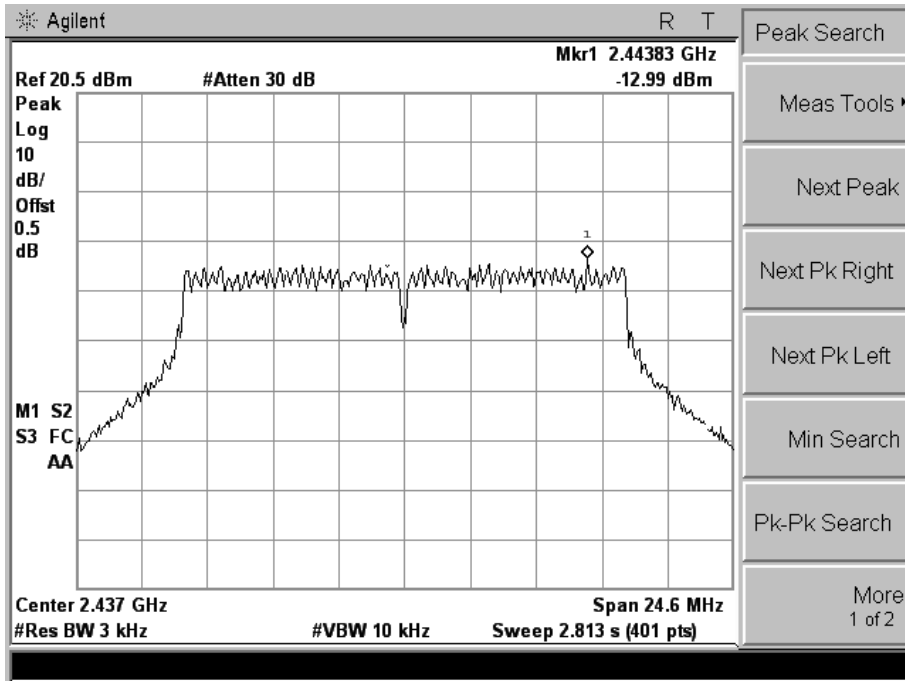

(CH Mid)

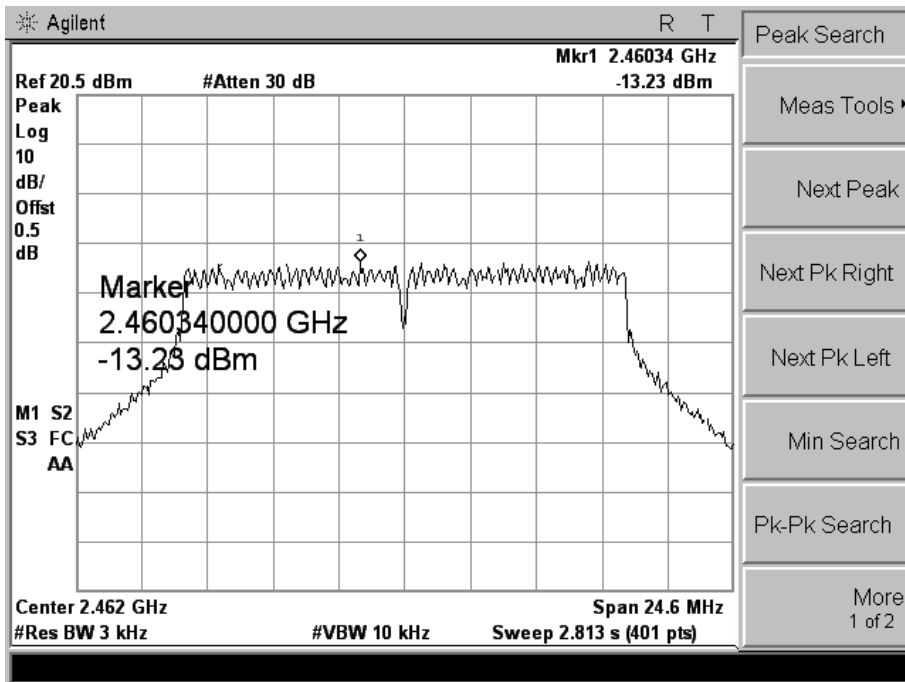

(CH High)

### 5.5.6.3 802.11n(20MHz) Test Mode

#### A. Test Verdict:

Channel	Frequency (MHz)	PSD (dBm)	Limits(dBm)	Result
1	2412	-15.46	≤8	PASS
7	2437	-14.67	≤8	PASS
11	2462	-14.44	≤8	PASS

#### B. Test Plot:

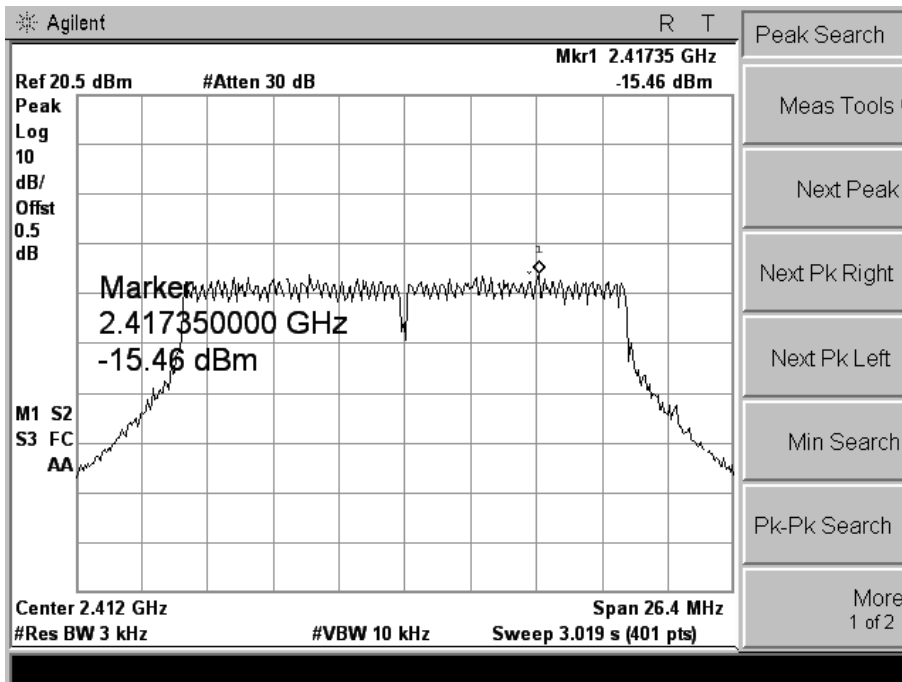

(CH Low)

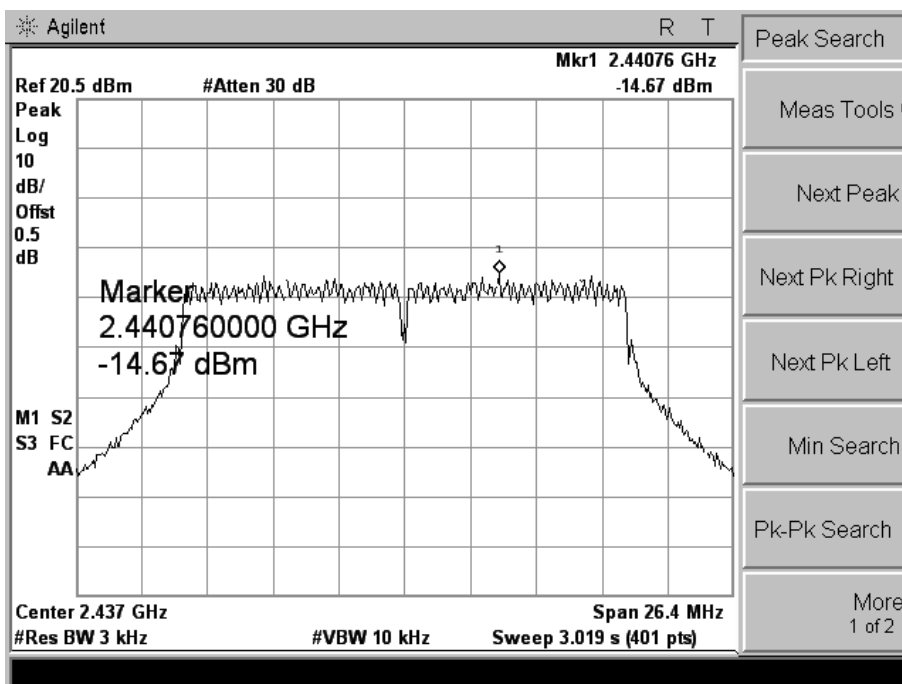

(CH Mid)

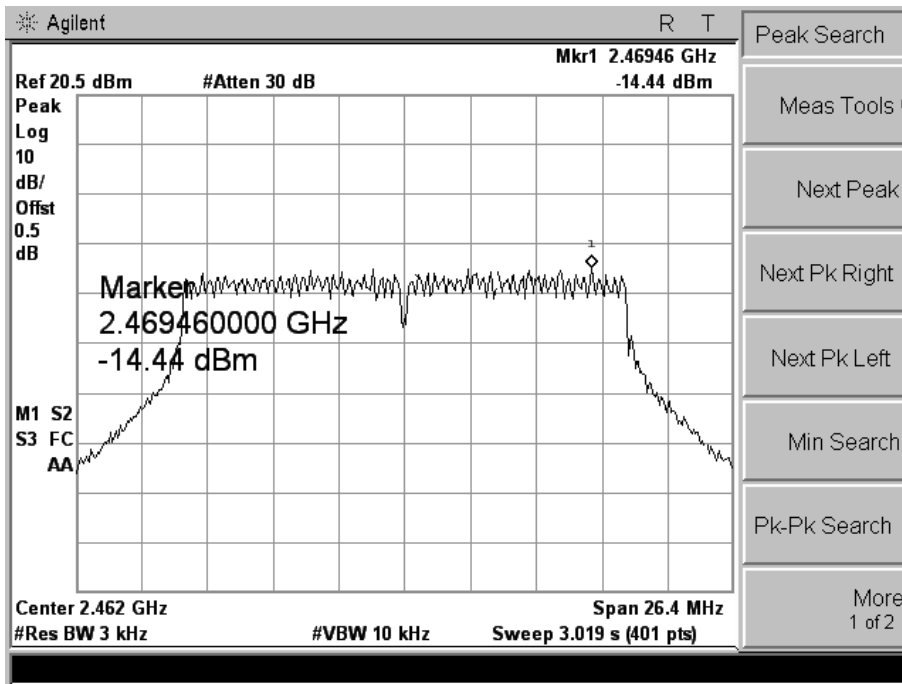

(CH High)

5.5.6.4 802.11n Test Mode (40MHz)

A. Test Verdict:

Channel	Frequency (MHz)	PSD (dBm)	Limits(dBm)	Result
3	2422	-17.76	≤8	PASS
7	2437	-15.90	≤8	PASS
9	2452	-16.47	≤8	PASS

B. Test Plot:

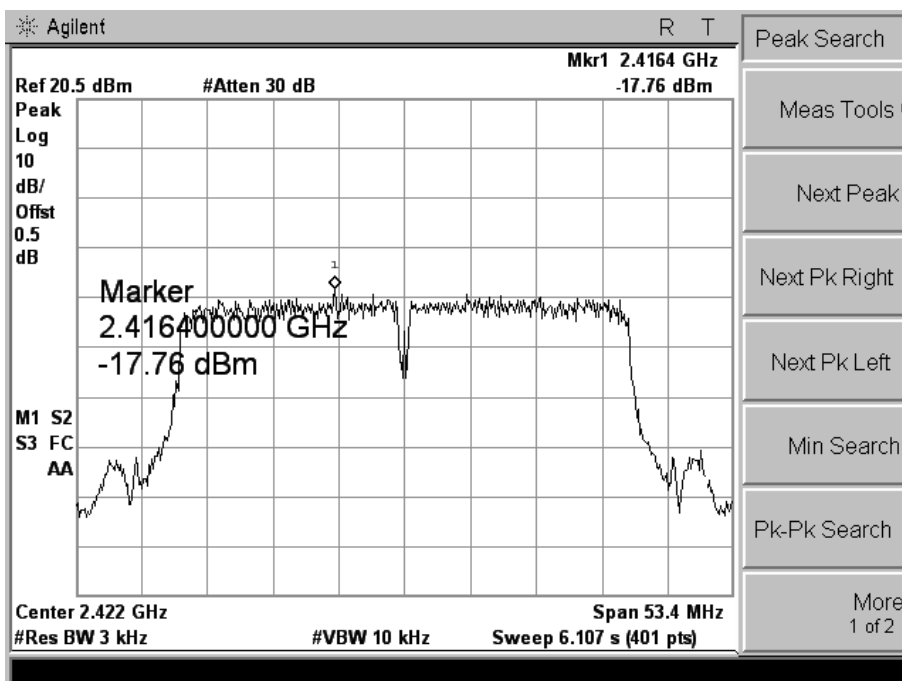

(CH Low)

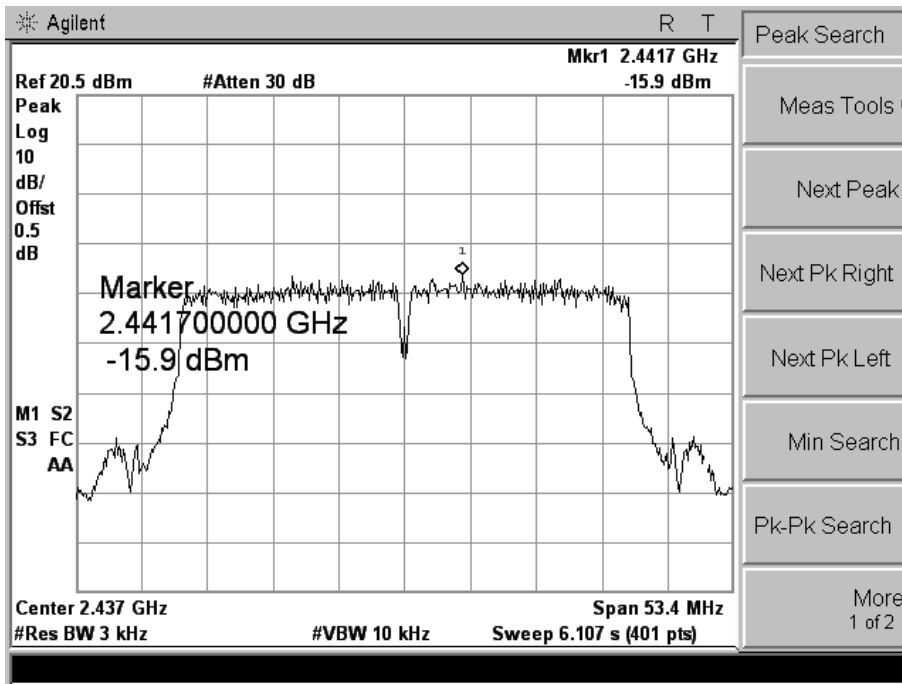

(CH Mid)

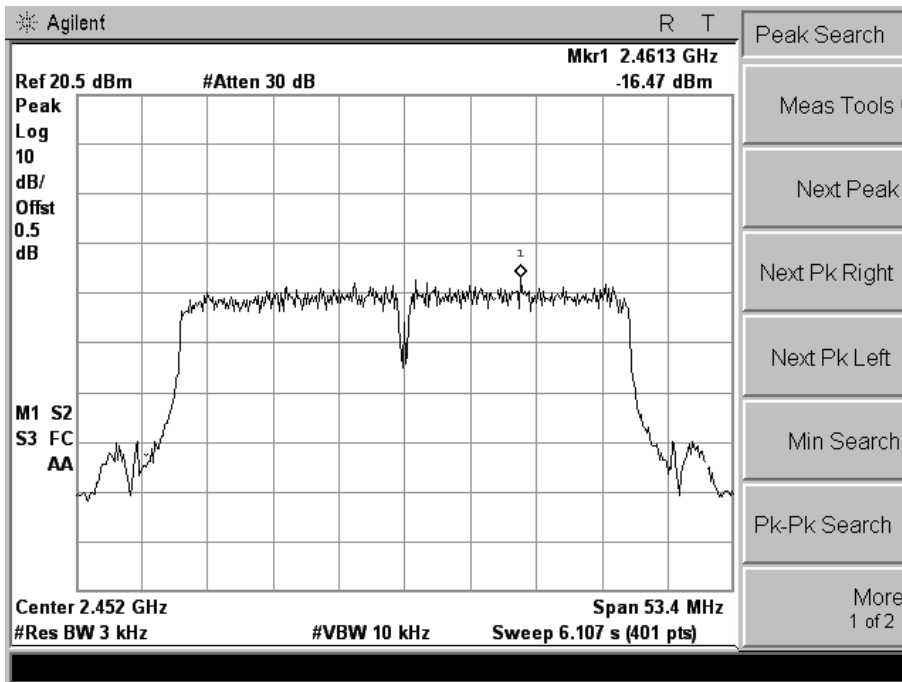

(CH High)



## 5.6 Conducted Emission

### 5.6.1 Definition

According to FCC section 15.207, for an intentional radiator that is designed to be connected to the public utility (AC) power line, the radio frequency voltage that is conducted back onto the AC power line on any frequency or frequencies, within the band 150 kHz to 30 MHz, shall not exceed the limits in the following table, as measured using a 50  $\mu$ H/50 ohms line impedance stabilization network (LISN).

Frequency	Maximum RF Line Voltage	
	Q.P.( dBuV)	Average( dBuV)
150kHz-500kHz	66-56	56-46
500kHz-5MHz	56	46
5MHz-30MHz	60	50

**Note:**

1. The lower limit shall apply at the transition frequency.
2. The limit decreases linearly with the logarithm of the frequency in the range 0.15 MHz to 0.50 MHz

### 5.6.2 Test Description

The EUT is powered by the Battery charged with the AC Adapter which is powered by 120V, 60Hz AC mains supply. The path loss as the factor is calibrated to correct the reading. During the measurement, the EUT is activated and is set to operate at maximum power.

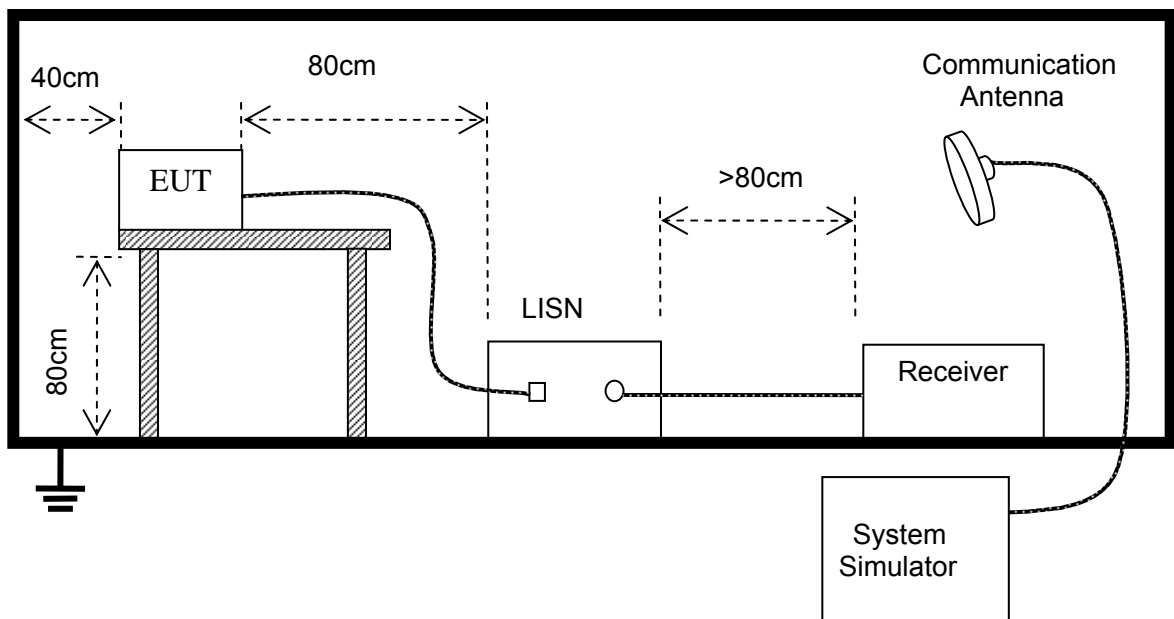

### 5.6.3 Test Result

A scan was taken on both power lines, Line 1 and Line 2, recording at least the six highest emissions. Emission frequency and amplitude were recorded into a computer in which correction factors were used to calculate the emission level and compare reading to the applicable limit. If EUT emission level was less -2dB to the A.V. limit in Peak mode, then the emission signal was re-checked using Q.P and Average detector.

The Wifi model was carried out for 802.11b/g/n modulation types with two adapters, 802.11b High channel modulation type was the worst case condition, The test data was shown on the summary data page.



Address: No. 5, Langshan 2nd Rd., North Hi-Tech Industrial park  
 Guangdong, China  
 Tel: 0755-86026850 Fax: 0755-26013350

**Conducted Emission Measurement**

File: HPM5      Data: #2      Date: 13/09/26/      Time: 10/47/57

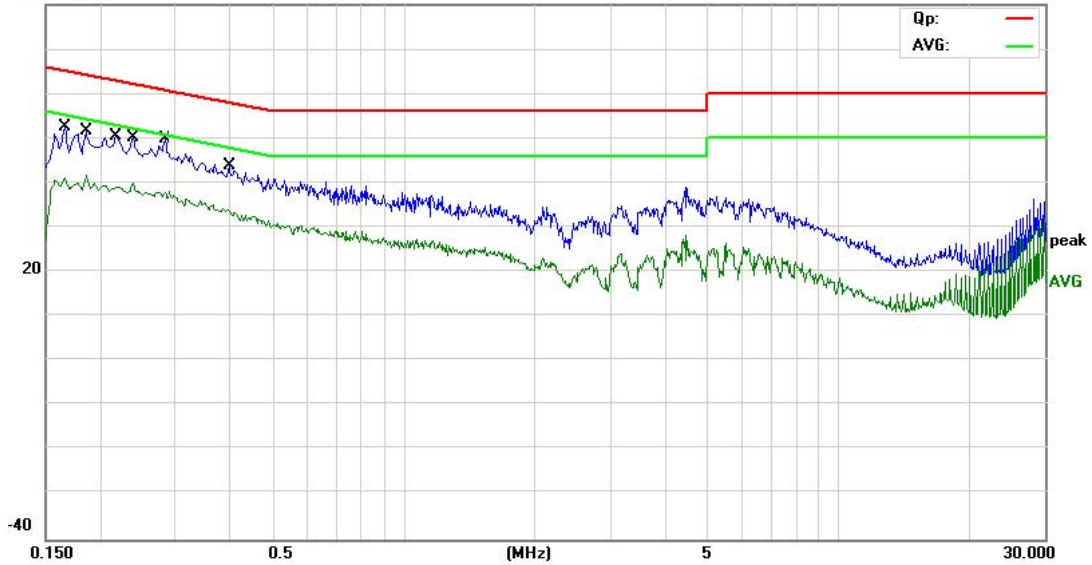

Site: MOST #1      Phase: **L1**      Temperature: 26  
 Limit: FCC Part15 B Class B QP      Power: DC 12V Adapter AC 120V/60Hz      Humidity: 60 %  
 EUT: Full HD Cloudio TV Set-Top Box  
 M/N: HPM5  
 Mode: WIFI Mode  
 Note:

No.	Mk.	Freq.	Reading Level	Correct Factor	Measurement	Limit	Over	Detector	Comment
		MHz	dBuV	dB	dBuV	dBuV	dB		
1		0.1640	30.37	9.84	40.21	55.26	-15.05	AVG	
2		0.1660	42.48	9.96	52.44	65.16	-12.72	QP	
3		0.1860	40.39	11.16	51.55	64.21	-12.66	QP	
4		0.1864	30.17	11.18	41.35	54.20	-12.85	AVG	
5		0.2162	27.00	11.89	38.89	52.96	-14.07	AVG	
6		0.2180	38.53	11.88	50.41	62.89	-12.48	QP	
7		0.2380	38.33	11.75	50.08	62.17	-12.09	QP	
8		0.2404	27.09	11.73	38.82	52.08	-13.26	AVG	
9		0.2802	26.03	11.47	37.50	50.81	-13.31	AVG	
10	*	0.2820	38.28	11.45	49.73	60.76	-11.03	QP	
11		0.3940	23.13	10.71	33.84	47.98	-14.14	AVG	
12		0.3980	33.27	10.68	43.95	57.90	-13.95	QP	

\*:Maximum data    x:Over limit    l:over margin

Engineer Signature: Allen



Address: No.5, Langshan 2nd Rd., North Hi-Tech Industrial park  
 Guangdong, China  
 Tel: 0755-86026850 Fax: 0755-26013350

**Conducted Emission Measurement**

File: HPM5      Data: #1      Date: 13/09/26/      Time: 10/41/14

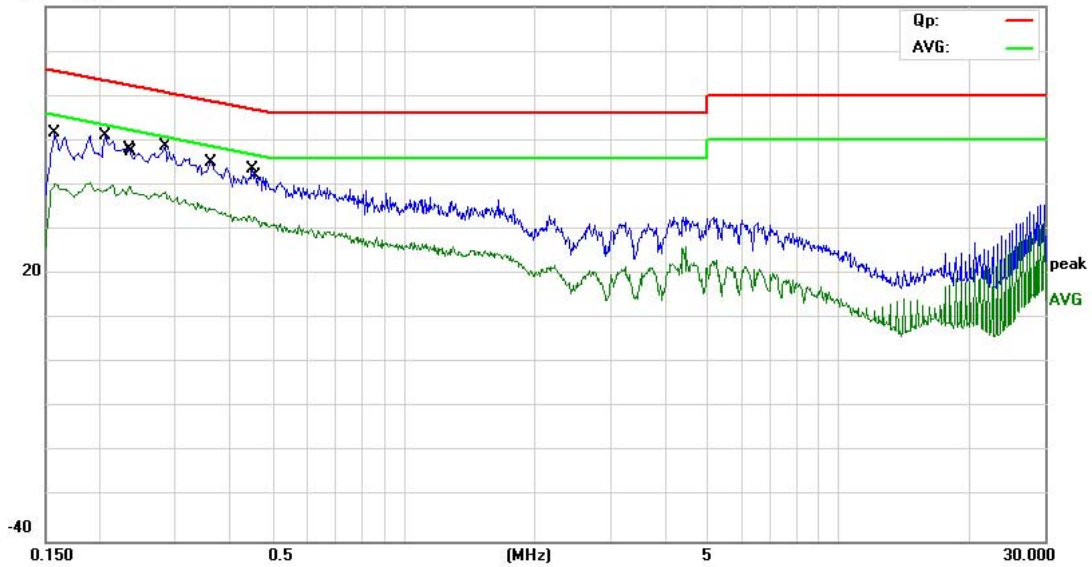

Site: MOST #1      Phase: **N**      Temperature: 26  
 Limit: FCC Part15 B Class B QP      Power: DC 12V Adapter AC 120V/60Hz      Humidity: 60 %  
 EUT: Full HD Cloudio TV Set-Top Box  
 M/N: HPM5  
 Mode: WIFI Mode  
 Note:

No.	Mk.	Freq. MHz	Reading Level dBuV	Correct Factor dB	Measure- ment dBuV	Limit dBuV	Over dB	Detector	Comment
1		0.1580	42.04	9.48	51.52	65.57	-14.05	QP	
2		0.1582	30.84	9.49	40.33	55.56	-15.23	AVG	
3		0.2028	26.58	11.98	38.56	53.50	-14.94	AVG	
4	*	0.2060	39.22	11.96	51.18	63.37	-12.19	QP	
5		0.2340	36.38	11.77	48.15	62.31	-14.16	QP	
6		0.2366	27.03	11.76	38.79	52.21	-13.42	AVG	
7		0.2787	26.64	11.48	38.12	50.85	-12.73	AVG	
8		0.2820	37.08	11.45	48.53	60.76	-12.23	QP	
9		0.3595	23.74	10.94	34.68	48.74	-14.06	AVG	
10		0.3620	34.28	10.92	45.20	58.68	-13.48	QP	
11		0.4467	22.14	10.36	32.50	46.94	-14.44	AVG	
12		0.4580	31.72	10.28	42.00	56.73	-14.73	QP	

\*:Maximum data    x:Over limit    !:over margin

Engineer Signature: Allen

## 5.7 Radiated Emission

### 5.7.1 Definition

According to FCC section 15.247(d), radiated emission outside the frequency band attenuation below the general limits specified in § 15.209(a) is not required. In addition, radiated emissions which fall in the restricted bands, as defined in § 15.205(a), must also comply with the radiated emission limits specified in § 15.209(a) (see § 15.205(c)).

According to FCC section 15.209 (a), except as provided elsewhere in this subpart, the emissions from an intentional radiator shall not exceed the field strength levels specified in the following table:

Frequency (MHz)	Field Strength ( $\mu\text{V}/\text{m}$ )	Measurement Distance (m)
0.009 - 0.490	2400/F(kHz)	300
0.490 - 1.705	24000/F(kHz)	30
1.705 - 30.0	30	30
30 - 88	100	3
88 - 216	150	3
216 - 960	200	3
Above 960	500	3

As shown in FCC section 15.35(b), for frequencies above 1000MHz, the field strength limits are based on average detector. When average radiated emission measurements are specified in this part, including emission measurements below 1000MHz, there also is a limit on the radio frequency emissions, as measured using instrumentation with a peak detector function, corresponding to 20dB above the maximum permitted average limit for the frequency being investigated unless a different peak emission limit is otherwise specified in the rules.

### 5.7.2 Test Description

#### A. Test Configuration:

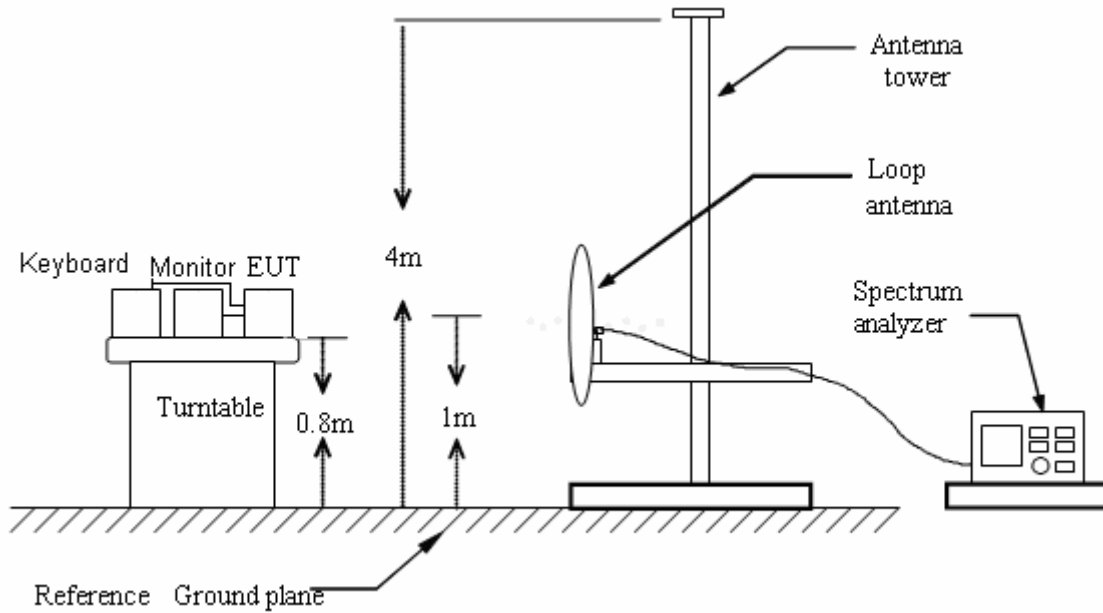

#### Below 1GHz:

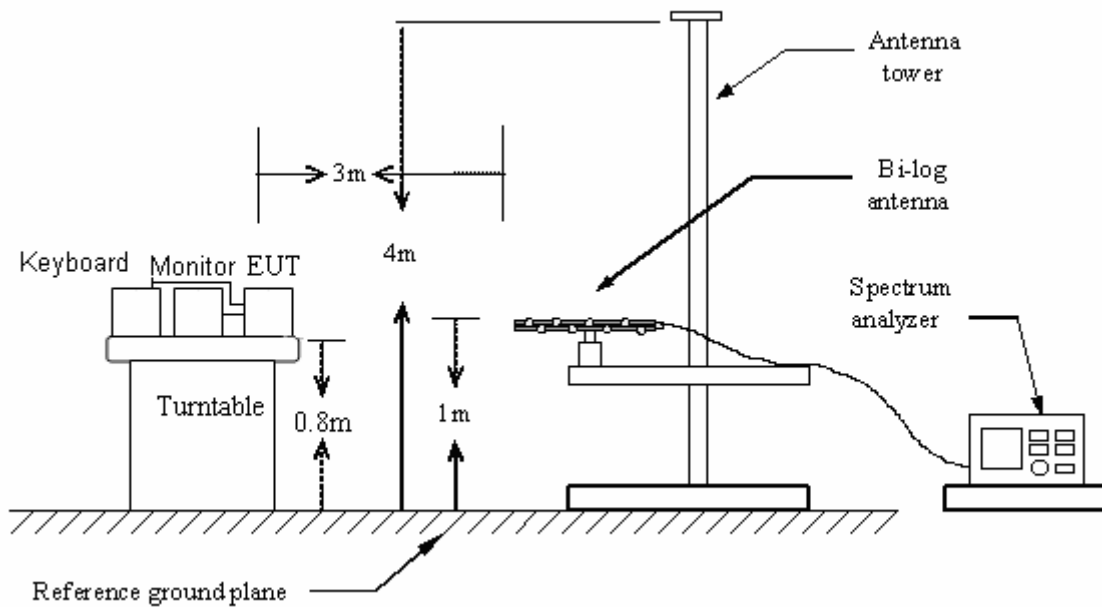

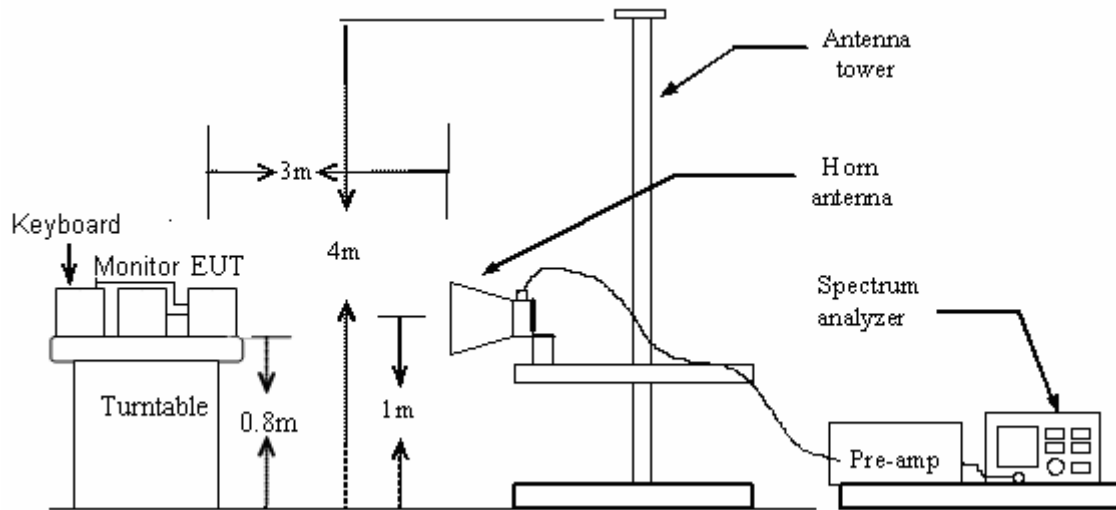
**Above 1GHz:****B. Test procedures**

1. The EUT is placed on a turntable, which is 0.8m above ground plane.
2. The turntable shall be rotated for 360 degrees to determine the position of maximum emission level.
3. EUT is set 3m away from the receiving antenna, which is varied from 1m to 4m to find out the highest emissions.
4. Maximum procedure was performed on the six highest emissions to ensure EUT compliance.
5. And also, each emission was to be maximized by changing the polarization of receiving antenna both horizontal and vertical.
6. Set the spectrum analyzer in the following setting as:
  - Below 1GHz: RBW=100 kHz / VBW=300 kHz / Sweep=AUTO
  - Above 1GHz : (a) PEAK: RBW=VBW=1MHz / Sweep=AUTO
  - (b) AVERAGE: RBW=1MHz / VBW=10Hz / Sweep=AUTO
7. Repeat above procedures until the measurements for all frequencies are complete.

**5.7.3 Test Result**

The Wifi model was carried out for 802.11b/g/n modulation types with two adapters, 802.11b High channel modulation type was the worst case condition, The test data was shown on the summary data page.

**From 9KHz to 30MHz:**

EUT:	Full HD Cloudio TV Set-Top Box	Model Name. :	HPM5
Temperature:	20 °C	Relative Humidity:	48%
Pressure:	1010 hPa	Test Voltage :	DC 12V by Adapter AC 120V/60Hz
Test Mode :	TX	Polarization :	--

Freq.	Reading	Limit	Margin	State
(MHz)	(dBuV/m)	(dBuV/m)	(dB)	P/F
--	--	--	--	PASS
--	--	--	--	PASS

**Note:**

The amplitude of spurious emissions which are attenuated by more than 20dB below the permissible value has no need to be reported.

Distance extrapolation factor =  $20 \log(\text{specific distance}/\text{test distance})$ (dB);

Limit line = specific limits(dBuV) + distance extrapolation factor.

**Conclusion: PASS**

**Below 1 GHz**



Address: No.5, Langshan 2nd Rd., North Hi-Tech Industrial park  
 Guangdong, China  
 Tel: 0755-86026850 Fax: 0755-26013350

**Radiated Emission Measurement**

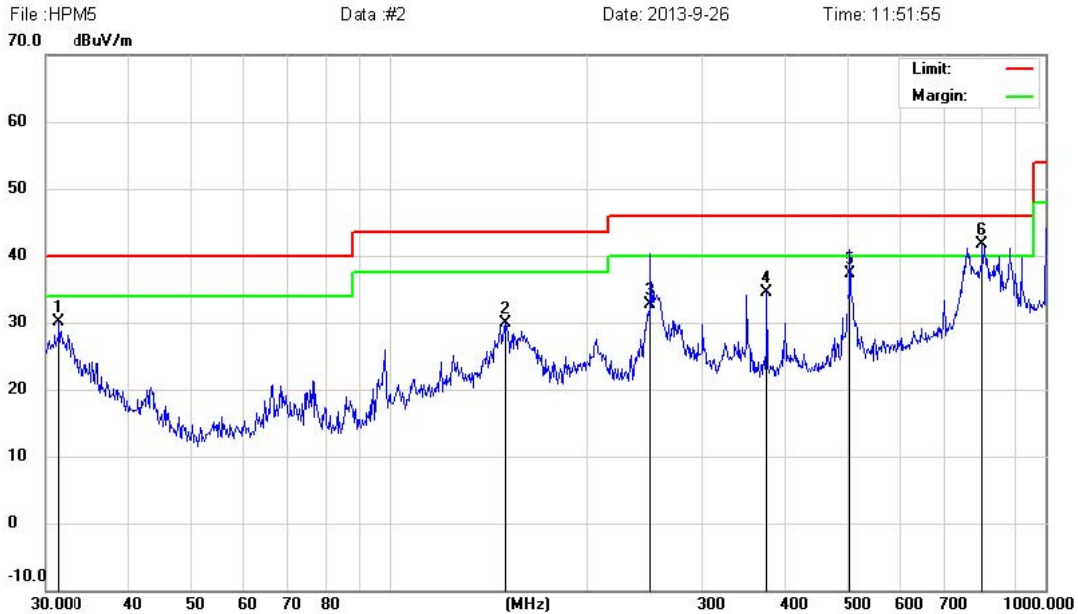

Site Chamber #1 Polarization: **Horizontal** Temperature: 26  
 Limit: FCC Part15 B 3M Radiation Power: DC 12V Adapter AC 120V/60Hz Humidity: 61 %  
 EUT: Full HD Cloudio TV Set-Top Box Distance:  
 M/N: HPM5  
 Mode: WIFI Mode  
 Note:

No.	Mk.	Freq.	Reading Level	Correct Factor	Measurement	Limit	Over	Antenna Height	Table Degree
		MHz	dBuV	dB	dBuV/m	dBuV/m	dB	cm	degree
1		31.3992	8.96	21.15	30.11	40.00	-9.89	QP	
2		151.0665	13.41	16.59	30.00	43.50	-13.50	QP	
3		250.2730	15.20	17.41	32.61	46.00	-13.39	QP	
4		375.9385	16.40	18.14	34.54	46.00	-11.46	QP	
5		502.4056	15.90	21.42	37.32	46.00	-8.68	QP	
6	*	801.7862	15.79	25.90	41.69	46.00	-4.31	QP	

\*:Maximum data x:Over limit l:over margin

Engineer Signature: Allen





Address: No. 5, Langshan 2nd Rd., North Hi-Tech Industrial park  
 Guangdong, China  
 Tel: 0755-86026850 Fax: 0755-26013350

**Radiated Emission Measurement**

File: HPM5 Data: #1 Date: 2013-9-26 Time: 11:47:15  
 70.0 dBuV/m

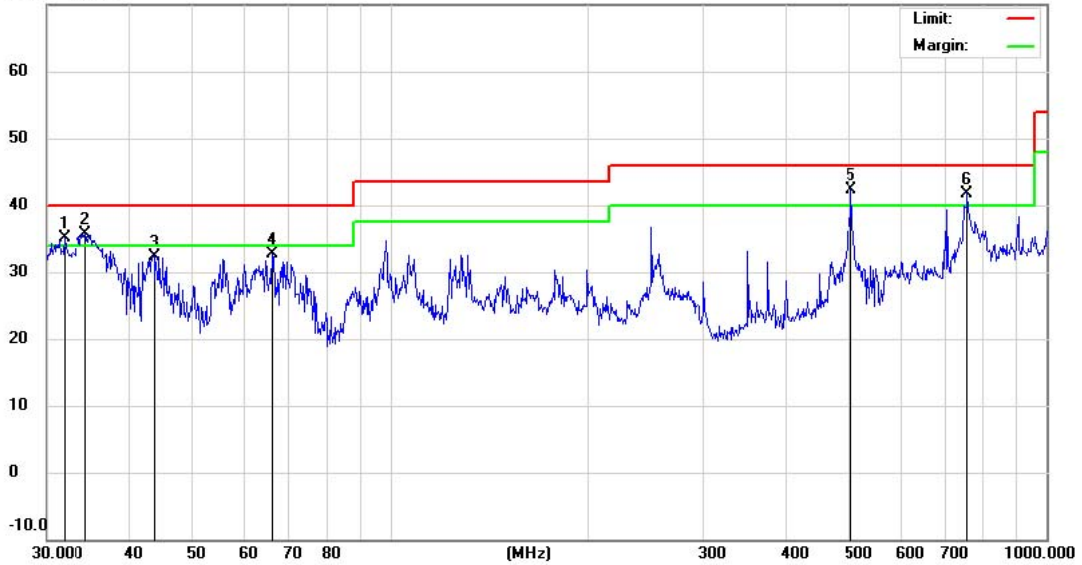

Site Chamber #1 Polarization: **Vertical** Temperature: 26  
 Limit: FCC Part15 B 3M Radiation Power: DC 12V Adapter AC 120V/60Hz Humidity: 61 %  
 EUT: Full HD Cloudio TV Set-Top Box Distance:  
 M/N: HPM5  
 Mode: WIFI Mode  
 Note:

No.	Mk.	Freq.	Reading Level	Correct Factor	Measurement	Limit	Over	Antenna Height	Table Degree
		MHz	dBuV	dB	dBuV/m	dBuV/m	dB	cm	degree
1	I	31.9545	13.29	21.79	35.08	40.00	-4.92	QP	
2	I	34.3963	15.65	20.04	35.69	40.00	-4.31	QP	
3		43.8119	18.53	13.83	32.36	40.00	-7.64	QP	
4		66.2661	21.35	11.37	32.72	40.00	-7.28	QP	
5	*	504.7062	20.76	21.45	42.21	46.00	-3.79	QP	
6	I	758.0407	16.16	25.64	41.80	46.00	-4.20	QP	

\*:Maximum data x:Over limit I:over margin

Engineer Signature: Allen

**Above 1 GHz**

**Operation Mode:** TX/ IEEE 802.11b/CH Low      **Test Date:** Sep. 26, 2013  
**Temperature:** 20°C      **Tested by:** Roy  
**Humidity:** 70 % RH      **Polarity:** Ver. / Hor.

Freq. (MHz)	Ant. Pol H/V	Peak Reading (dBuV)	AV Reading (dBuV)	Ant. / CL CF (dB)	Actual Fs		Peak Limit (dBuV/m)	AV Limit (dBuV/m)	AV Margin (dB)
					Peak (dBuV/m)	AV (dBuV/m)			
4824.0	H	32.34	13.87	23.54	55.88	37.41	74.00	54.00	-16.59
N/A	H								
4824.0	V	31.92	12.76	23.36	55.28	36.12	74.00	54.00	-17.88
N/A	V								

**Notes:**

1. Measuring frequencies from 1 GHz to the 10th harmonic of highest fundamental frequency.
2. Radiated emissions measured in frequency above 1000MHz were made with an instrument using peak/average detector mode.
3. Average test would be performed if the peak result were greater than the average limit or as required by the applicant.
4. Data of measurement within this frequency range shown " --- " in the table above means the reading of emissions are attenuated more than 20dB below the permissible limits or the field strength is too small to be measured.
5. Measurements above show only up to 6 maximum emissions noted, or would be lesser, with " N/A " remark, if no specific emissions from the EUT are recorded (ie: margin>20dB from the applicable limit) and considered that's already beyond the background noise floor.
6. Margin (dB) = Remark result (dBuV/m) – Average limit (dBuV/m).

**Operation Mode:** TX/ IEEE 802.11b/CH MID      **Test Date:** Sep. 25, 2013  
**Temperature:** 20°C      **Tested by:** Roy  
**Humidity:** 70 % RH      **Polarity:** Ver. / Hor.

Freq. (MHz)	Ant. Pol H/V	Peak Reading (dBuV)	AV Reading (dBuV)	Ant. / CL CF (dB)	Actual Fs		Peak Limit (dBuV/m)	AV Limit (dBuV/m)	AV Margin (dB)
					Peak (dBuV/m)	AV (dBuV/m)			
4874.0	H	35.43	16.87	23.54	58.97	40.41	74.00	54.00	-13.59
N/A	H								
4874.0	V	35.50	15.97	23.36	58.86	39.33	74.00	54.00	-14.67
N/A	V								

**Notes:**

1. Measuring frequencies from 1 GHz to the 10th harmonic of highest fundamental frequency.
2. Radiated emissions measured in frequency above 1000MHz were made with an instrument using peak/average detector mode.
3. Average test would be performed if the peak result were greater than the average limit or as required by the applicant.
4. Data of measurement within this frequency range shown " --- " in the table above means the reading of emissions are attenuated more than 20dB below the permissible limits or the field strength is too small to be measured.
5. Measurements above show only up to 6 maximum emissions noted, or would be lesser, with " N/A " remark, if no specific emissions from the EUT are recorded (ie: margin>20dB from the applicable limit) and considered that's already beyond the background noise floor.
6. Margin (dB) = Remark result (dBuV/m) – Average limit (dBuV/m).

**Operation Mode:** TX/ IEEE 802.11b/CH High      **Test Date:** Sep. 25, 2013  
**Temperature:** 20°C      **Tested by:** Roy  
**Humidity:** 70 % RH      **Polarity:** Ver. / Hor.

Freq. (MHz)	Ant. Pol H/V	Peak Reading (dBuV)	AV Reading (dBuV)	Ant. / CL CF (dB)	Actual Fs		Peak Limit (dBuV/m)	AV Limit (dBuV/m)	AV Margin (dB)
					Peak (dBuV/m)	AV (dBuV/m)			
4924.0	H	31.98	11.26	23.54	55.52	34.80	74.00	54.00	-19.20
N/A	H								
4924.0	V	32.03	11.76	23.36	55.39	35.12	74.00	54.00	-18.88
N/A	V								

**Notes:**

1. Measuring frequencies from 1 GHz to the 10th harmonic of highest fundamental frequency.
2. Radiated emissions measured in frequency above 1000MHz were made with an instrument using peak/average detector mode.
3. Average test would be performed if the peak result were greater than the average limit or as required by the applicant.
4. Data of measurement within this frequency range shown “ --- ” in the table above means the reading of emissions are attenuated more than 20dB below the permissible limits or the field strength is too small to be measured.
5. Measurements above show only up to 6 maximum emissions noted, or would be lesser, with “ N/A ” remark, if no specific emissions from the EUT are recorded (ie: margin>20dB from the applicable limit) and considered that's already beyond the background noise floor.
6. Margin (dB) = Remark result (dBuV/m) – Average limit (dBuV/m).

**Operation Mode:** TX/ IEEE 802.11g/CH Low      **Test Date:** Sep. 25, 2013  
**Temperature:** 20°C      **Tested by:** Roy  
**Humidity:** 70 % RH      **Polarity:** Ver. / Hor.

Freq. (MHz)	Ant. Pol H/V	Peak Reading (dBuV)	AV Reading (dBuV)	Ant. / CL CF (dB)	Actual Fs		Peak Limit (dBuV/m)	AV Limit (dBuV/m)	AV Margin (dB)
					Peak (dBuV/m)	AV (dBuV/m)			
4824.0	H	32.18	12.98	23.78	55.96	36.76	74.00	54.00	-17.24
N/A	H								
4824.0	V	30.88	11.03	24.01	54.89	35.04	74.00	54.00	-18.96
N/A	V								

**Notes:**

1. Measuring frequencies from 1 GHz to the 10th harmonic of highest fundamental frequency.
2. Radiated emissions measured in frequency above 1000MHz were made with an instrument using peak/average detector mode.
3. Average test would be performed if the peak result were greater than the average limit or as required by the applicant.
4. Data of measurement within this frequency range shown " --- " in the table above means the reading of emissions are attenuated more than 20dB below the permissible limits or the field strength is too small to be measured.
5. Measurements above show only up to 6 maximum emissions noted, or would be lesser, with " N/A " remark, if no specific emissions from the EUT are recorded (ie: margin>20dB from the applicable limit) and considered that's already beyond the background noise floor.
6. Margin (dB) = Remark result (dBuV/m) – Average limit (dBuV/m).

**Operation Mode:** TX/ IEEE 802.11g/CH MID      **Test Date:** Sep. 25, 2013  
**Temperature:** 20°C      **Tested by:** Roy  
**Humidity:** 70 % RH      **Polarity:** Ver. / Hor.

Freq. (MHz)	Ant. Pol H/V	Peak Reading (dBuV)	AV Reading (dBuV)	Ant. / CL CF (dB)	Actual Fs		Peak Limit (dBuV/m)	AV Limit (dBuV/m)	AV Margin (dB)
					Peak (dBuV/m)	AV (dBuV/m)			
4874.0	H	32.22	13.37	23.78	56.00	37.15	74.00	54.00	-16.85
N/A	H								
4874.0	V	31.64	11.01	24.01	55.65	35.02	74.00	54.00	-18.98
N/A	V								

**Notes:**

1. Measuring frequencies from 1 GHz to the 10th harmonic of highest fundamental frequency.
2. Radiated emissions measured in frequency above 1000MHz were made with an instrument using peak/average detector mode.
3. Average test would be performed if the peak result were greater than the average limit or as required by the applicant.
4. Data of measurement within this frequency range shown " --- " in the table above means the reading of emissions are attenuated more than 20dB below the permissible limits or the field strength is too small to be measured.
5. Measurements above show only up to 6 maximum emissions noted, or would be lesser, with " N/A " remark, if no specific emissions from the EUT are recorded (ie: margin>20dB from the applicable limit) and considered that's already beyond the background noise floor.
6. Margin (dB) = Remark result (dBuV/m) – Average limit (dBuV/m).

**Operation Mode:** TX/ IEEE 802.11g/CH High      **Test Date:** Sep. 25, 2013  
**Temperature:** 20°C      **Tested by:** Roy  
**Humidity:** 70 % RH      **Polarity:** Ver. / Hor.

Freq. (MHz)	Ant. Pol H/V	Peak Reading (dBuV)	AV Reading (dBuV)	Ant. / CL CF (dB)	Actual Fs		Peak Limit (dBuV/m)	AV Limit (dBuV/m)	AV Margin (dB)
					Peak (dBuV/m)	AV (dBuV/m)			
4924.0	H	31.78	11.12	23.78	55.56	34.90	74.00	54.00	-19.10
N/A	H								
4924.0	V	30.94	10.69	24.01	54.95	34.70	74.00	54.00	-19.30
N/A	V								

**Notes:**

1. Measuring frequencies from 1 GHz to the 10th harmonic of highest fundamental frequency.
2. Radiated emissions measured in frequency above 1000MHz were made with an instrument using peak/average detector mode.
3. Average test would be performed if the peak result were greater than the average limit or as required by the applicant.
4. Data of measurement within this frequency range shown " --- " in the table above means the reading of emissions are attenuated more than 20dB below the permissible limits or the field strength is too small to be measured.
5. Measurements above show only up to 6 maximum emissions noted, or would be lesser, with " N/A " remark, if no specific emissions from the EUT are recorded (ie: margin>20dB from the applicable limit) and considered that's already beyond the background noise floor.
6. Margin (dB) = Remark result (dBuV/m) – Average limit (dBuV/m).

**Operation Mode:** TX/ IEEE 802.11n(20MHz)/CH Low      **Test Date:** Sep. 25, 2013  
**Temperature:** 20°C      **Tested by:** Roy  
**Humidity:** 70 % RH      **Polarity:** Ver. / Hor.

Freq. (MHz)	Ant. Pol H/V	Peak Reading (dBuV)	AV Reading (dBuV)	Ant. / CL CF (dB)	Actual Fs		Peak Limit (dBuV/m)	AV Limit (dBuV/m)	AV Margin (dB)
					Peak (dBuV/m)	AV (dBuV/m)			
4824.0	H	30.31	10.07	24.02	54.33	34.09	74.00	54.00	-19.91
N/A	H								
4824.0	V	30.76	10.94	24.68	55.44	35.62	74.00	54.00	-18.38
N/A	V								

**Notes:**

1. Measuring frequencies from 1 GHz to the 10th harmonic of highest fundamental frequency.
2. Radiated emissions measured in frequency above 1000MHz were made with an instrument using peak/average detector mode.
3. Average test would be performed if the peak result were greater than the average limit or as required by the applicant.
4. Data of measurement within this frequency range shown “ --- ” in the table above means the reading of emissions are attenuated more than 20dB below the permissible limits or the field strength is too small to be measured.
5. Measurements above show only up to 6 maximum emissions noted, or would be lesser, with “ N/A ” remark, if no specific emissions from the EUT are recorded (ie: margin>20dB from the applicable limit) and considered that's already beyond the background noise floor.
6. Margin (dB) = Remark result (dBuV/m) – Average limit (dBuV/m).



**Operation Mode:** TX/ IEEE 802.11n(20MHz)/CH Mid  
**Temperature:** 20°C  
**Humidity:** 70 % RH  
**Test Date:** Sep. 25, 2013  
**Tested by:** Roy  
**Polarity:** Ver. / Hor.

Freq. (MHz)	Ant. Pol H/V	Peak Reading (dBuV)	AV Reading (dBuV)	Ant. / CL CF (dB)	Actual Fs		Peak Limit (dBuV/m)	AV Limit (dBuV/m)	AV Margin (dB)
					Peak (dBuV/m)	AV (dBuV/m)			
4874.0	H	31.03	11.17	24.02	55.05	35.19	74.00	54.00	-18.81
N/A	H								
4874.0	V	30.26	10.83	24.68	54.94	35.51	74.00	54.00	-18.49
N/A	V								

**Notes:**

1. Measuring frequencies from 1 GHz to the 10th harmonic of highest fundamental frequency.
2. Radiated emissions measured in frequency above 1000MHz were made with an instrument using peak/average detector mode.
3. Average test would be performed if the peak result were greater than the average limit or as required by the applicant.
4. Data of measurement within this frequency range shown “ --- ” in the table above means the reading of emissions are attenuated more than 20dB below the permissible limits or the field strength is too small to be measured.
5. Measurements above show only up to 6 maximum emissions noted, or would be lesser, with “ N/A ” remark, if no specific emissions from the EUT are recorded (ie: margin>20dB from the applicable limit) and considered that's already beyond the background noise floor.
- 6 Margin (dB) = Remark result (dBuV/m) – Average limit (dBuV/m).

**Operation Mode:** TX/ IEEE 802.11n(20MHz)/CH High  
**Temperature:** 20°C  
**Humidity:** 70 % RH  
**Test Date:** Sep. 25, 2013  
**Tested by:** Roy  
**Polarity:** Ver. / Hor.

Freq. (MHz)	Ant. Pol H/V	Peak Reading (dBuV)	AV Reading (dBuV)	Ant. / CL CF (dB)	Actual Fs		Peak Limit (dBuV/m)	AV Limit (dBuV/m)	AV Margin (dB)
					Peak (dBuV/m)	AV (dBuV/m)			
4924.0	H	30.42	10.84	24.02	54.44	34.86	74.00	54.00	-18.75
N/A	H								
4924.0	V	29.63	10.44	24.68	54.31	35.12	74.00	54.00	-18.88
N/A	V								

**Notes:**

1. Measuring frequencies from 1 GHz to the 10th harmonic of highest fundamental frequency.
2. Radiated emissions measured in frequency above 1000MHz were made with an instrument using peak/average detector mode.
3. Average test would be performed if the peak result were greater than the average limit or as required by the applicant.
4. Data of measurement within this frequency range shown “ --- ” in the table above means the reading of emissions are attenuated more than 20dB below the permissible limits or the field strength is too small to be measured.
5. Measurements above show only up to 6 maximum emissions noted, or would be lesser, with “ N/A ” remark, if no specific emissions from the EUT are recorded (ie: margin>20dB from the applicable limit) and considered that's already beyond the background noise floor.
6. Margin (dB) = Remark result (dBuV/m) – Average limit (dBuV/m).

**Operation Mode:** TX/ IEEE 802.11n(40MHz)/CH Low      **Test Date:** Sep. 25, 2013  
**Temperature:** 20°C      **Tested by:** Roy  
**Humidity:** 70 % RH      **Polarity:** Ver. / Hor.

Freq. (MHz)	Ant. Pol H/V	Peak Reading (dBuV)	AV Reading (dBuV)	Ant. / CL CF (dB)	Actual Fs		Peak Limit (dBuV/m)	AV Limit (dBuV/m)	AV Margin (dB)
					Peak	AV			
					(dBuV/m)	(dBuV/m)			
4844.0	H	32.85	12.19	23.98	56.83	36.17	74.00	54.00	-17.83
N/A	H								
4844.0	V	32.07	11.96	24.05	56.12	36.01	74.00	54.00	-17.99
N/A	V								

**Notes:**

1. Measuring frequencies from 1 GHz to the 10th harmonic of highest fundamental frequency.
2. Radiated emissions measured in frequency above 1000MHz were made with an instrument using peak/average detector mode.
3. Average test would be performed if the peak result were greater than the average limit or as required by the applicant.
4. Data of measurement within this frequency range shown “ --- ” in the table above means the reading of emissions are attenuated more than 20dB below the permissible limits or the field strength is too small to be measured.
5. Measurements above show only up to 6 maximum emissions noted, or would be lesser, with “ N/A ” remark, if no specific emissions from the EUT are recorded (ie: margin>20dB from the applicable limit) and considered that's already beyond the background noise floor.
6. Margin (dB) = Remark result (dBuV/m) – Average limit (dBuV/m).

**Operation Mode:** TX/ IEEE 802.11n(40MHz)/CH Mid      **Test Date:** Sep. 25, 2013  
**Temperature:** 20°C      **Tested by:** Roy  
**Humidity:** 70 % RH      **Polarity:** Ver. / Hor.

Freq. (MHz)	Ant. Pol H/V	Peak Reading (dBuV)	AV Reading (dBuV)	Ant. / CL CF (dB)	Actual Fs		Peak Limit (dBuV/m)	AV Limit (dBuV/m)	AV Margin (dB)
					Peak (dBuV/m)	AV (dBuV/m)			
4874.0	H	33.85	12.27	23.98	57.83	36.25	74.00	54.00	-17.75
N/A	H								
4874.0	V	33.36	12.10	24.05	57.41	36.15	74.00	54.00	-17.85
N/A	V								

**Notes:**

1. Measuring frequencies from 1 GHz to the 10th harmonic of highest fundamental frequency.
2. Radiated emissions measured in frequency above 1000MHz were made with an instrument using peak/average detector mode.
3. Average test would be performed if the peak result were greater than the average limit or as required by the applicant.
4. Data of measurement within this frequency range shown “ --- ” in the table above means the reading of emissions are attenuated more than 20dB below the permissible limits or the field strength is too small to be measured.
5. Measurements above show only up to 6 maximum emissions noted, or would be lesser, with “ N/A ” remark, if no specific emissions from the EUT are recorded (ie: margin>20dB from the applicable limit) and considered that's already beyond the background noise floor.
- 7 Margin (dB) = Remark result (dBuV/m) – Average limit (dBuV/m).

**Operation Mode:** TX/ IEEE 802.11n(40MHz)/CH High  
**Temperature:** 20°C  
**Humidity:** 70 % RH  
**Test Date:** Sep. 25, 2013  
**Tested by:** Roy  
**Polarity:** Ver. / Hor.

Freq. (MHz)	Ant. Pol H/V	Peak Reading (dBuV)	AV Reading (dBuV)	Ant. / CL CF (dB)	Actual Fs		Peak Limit (dBuV/m)	AV Limit (dBuV/m)	AV Margin (dB)
					Peak (dBuV/m)	AV (dBuV/m)			
4904.0	H	32.43	12.21	23.98	56.41	36.19	74.00	54.00	-17.81
N/A	H								
4904.0	V	31.87	11.33	24.05	55.92	35.38	74.00	54.00	-18.62
N/A	V								

**Notes:**

1. Measuring frequencies from 1 GHz to the 10th harmonic of highest fundamental frequency.
2. Radiated emissions measured in frequency above 1000MHz were made with an instrument using peak/average detector mode.
3. Average test would be performed if the peak result were greater than the average limit or as required by the applicant.
4. Data of measurement within this frequency range shown “ --- ” in the table above means the reading of emissions are attenuated more than 20dB below the permissible limits or the field strength is too small to be measured.
5. Measurements above show only up to 6 maximum emissions noted, or would be lesser, with “ N/A ” remark, if no specific emissions from the EUT are recorded (ie: margin>20dB from the applicable limit) and considered that's already beyond the background noise floor.
6. Margin (dB) = Remark result (dBuV/m) – Average limit (dBuV/m).

**APPENDIX 1**  
**PHOTOGRAPHS OF TEST SETUP**

### Bandwidth TEST SETUP



-----END OF REPORT-----