



FCC 47 CFR PART 15 SUBPART C

CERTIFICATION TEST REPORT

For

**4K IPTV Set Top Box
MODEL NUMBER: A12E**

FCC ID: WNA-A12E

REPORT NUMBER: 4787944978.2-1

ISSUE DATE: June 15, 2017

Prepared for

**Shenzhen Skyworth Digital Technology Co., Ltd
Unit A14/F. Skyworth Building, Gaoxin Ave.1s., Nanshan District, Shenzhen, China**

Prepared by

**UL-CCIC Company Ltd. Suzhou Branch
No. 2, Chengwan Road, Suzhou Industrial Park, Suzhou 215122, China
Tel: +86-512-6808 6400
Fax: +86-512-6808 4099
Website: www.ul.com**

The results reported herein have been performed in accordance with the laboratory's terms of accreditation. This report shall not be reproduced except in full without the written approval of the Laboratory. The results in this report apply to the test sample(s) mentioned above at the time of the testing period only and are not to be used to indicate applicability to other similar products. This report does not imply that the product(s) has met the criteria for certification.

Revision History

<u>Rev.</u>	<u>Issue Date</u>	<u>Revisions</u>	<u>Revised By</u>
--	06/15/2017	Initial Issue	

Summary of Test Results			
Clause	Test Items	FCC/IC Rules	Test Results
1	20dB Bandwidth	FCC 15.247 (a) (1) IC RSS-247 Clause 5.1 (1)	Complied
2	Peak Conducted Output Power	FCC 15.247 (b) (1) IC RSS-247 Clause 5.4 (b)	Complied
3	Carrier Hopping Channel Separation	FCC 15.247 (a) (1) IC RSS-247 Clause 5.1 (2)	Complied
4	Number of Hopping Frequency	15.247 (a) (1) III IC RSS-247 Clause 5.1 (4)	Complied
5	Time of Occupancy (Dwell Time)	15.247 (a) (1) III IC RSS-247 Clause 5.1 (4)	Complied
6	Conducted Bandedge and Spurious	FCC 15.247 (d) IC RSS-247 Clause 5.5	Complied
7	Radiated Bandedge and Spurious	FCC 15.247 (d) FCC 15.209 FCC 15.205 IC RSS-247 Clause 5.5 IC RSS-GEN Clause 8.9	Complied
8	Conducted Emission Test For AC Power Port	FCC 15.207 RSS-GEN Clause 8.8	Complied
9	Antenna Requirement	FCC 15.203 RSS-GEN Clause 8.3	Complied
Remark: N/A is an abbreviation for Not Applicable, and means this item is not applicable for this device.			

TABLE OF CONTENTS

1. ATTESTATION OF TEST RESULTS	6
2. TEST METHODOLOGY	6
3. FACILITIES AND ACCREDITATION	7
4. CALIBRATION AND UNCERTAINTY	8
4.1. MEASURING INSTRUMENT CALIBRATION.....	8
4.2. MEASUREMENT UNCERTAINTY.....	8
5. EQUIPMENT UNDER TEST	9
5.1. DESCRIPTION OF EUT.....	9
5.2. MAXIMUM OUTPUT POWER.....	9
5.3. PACKET TYPE CONFIGURATION.....	9
5.4. CHANNEL LIST.....	10
5.5. TEST CHANNEL CONFIGURATION.....	10
5.6. THE WORSE CASE POWER SETTING PARAMETER.....	10
5.7. DESCRIPTION OF AVAILABLE ANTENNAS.....	11
5.8. WORST-CASE CONFIGURATIONS.....	11
5.9. DESCRIPTION OF TEST SETUP.....	11
5.10. MEASURING INSTRUMENT AND SOFTWARE USED.....	13
6. MEASUREMENT METHODS	14
6.1. 20 dB BANDWIDTH AND 99% BANDWIDTH.....	15
6.2. PEAK CONDUCTED OUTPUT POWER.....	18
6.3. CARRIER HOPPING CHANNEL SEPARATION.....	20
6.4. NUMBER OF HOPPING FREQUENCY.....	22
6.5. TIME OF OCCUPANCY (DWELL TIME).....	24
6.6. CONDUCTED BANDEDGE AND SPURIOUS EMISSIONS.....	28
7. RADIATED TEST RESULTS	32
7.1. LIMITS AND PROCEDURE.....	32
7.2. RESTRICTED BANDEDGE.....	36
7.2.1. GFSK MODE.....	36
7.2.2. 8-DPSK MODE.....	40
7.3. SPURIOUS EMISSIONS (1~25GHz).....	44
7.4. SPURIOUS EMISSIONS 30M ~ 1 GHz.....	45
7.4.1. GFSK MODE.....	45
7.5. SPURIOUS EMISSIONS BELOW 30M.....	46

8. AC POWER LINE CONDUCTED EMISSIONS.....	47
9. ANTENNA REQUIREMENTS.....	50

1. ATTESTATION OF TEST RESULTS

Applicant Information

Company Name: Shenzhen Skyworth Digital Technology Co., Ltd
Address: Unit A14/F. Skyworth Building, Gaoxin Ave.1s., Nanshan District, Shenzhen, China

Manufacturer Information

Company Name: Shenzhen Synchron Electronics Co., Ltd.
Address: Unit A14/F. Skyworth Building, Gaoxin Ave.1s., Nanshan District, Shenzhen, China

EUT Description

Product Name: 4K IPTV Set Top Box
Brand Name: VectorMax
Model Name: A12E
FCC ID: WNA-A12E
Date Tested: June 08, 2017 ~ June 12, 2017

APPLICABLE STANDARDS	
STANDARD	TEST RESULTS
CFR 47 Part 15 Subpart C	PASS

Tested By:



Leo Liu
Engineer

Check By:



Shawn Wen
Laboratory Leader

Approved By:



Stephen Guo
Laboratory Manager

2. TEST METHODOLOGY

The tests documented in this report were performed in accordance with FCC CFR 47 Part 2, FCC CFR 47 Part 15, ANSI C63.10-2013, RSS-GEN Issue 4, and RSS-247 Issue 2.

3. FACILITIES AND ACCREDITATION

Test Location	Dongguan Dongdian Testing Service Co., Ltd
Address	No. 17, Zongbu Road 2, Songshan Lake Sci&Tech, Dongguan City, Guangdong Province, 523808, China
Accreditation Certificate	<p>Dongguan Dongdian Testing Service Co., Ltd. EMC Laboratory has been accredited by A2LA for technical competence in the field of electrical testing, and proved to be in compliance with ISO/IEC 17025: 2005 General Requirements for the Competence of Testing and Calibration Laboratories and any additional program requirements in the identified field of testing. Valid time is until January 31, 2018.</p> <p>Dongguan Dongdian Testing Service Co., Ltd. EMC Laboratory has been registered and fully described in a report filed with the FCC (Federal Communications Commission). The acceptance letter from the FCC is maintained in our files. Registration 270092, Renewal date March 11, 2015, valid time is until March 11, 2018.</p> <p>The 3m Alternate Test Site of Dongguan Dongdian Testing Service Co., Ltd. has been registered by Certification and Engineering Bureau of Industry Canada for the performance of radiated measurements with Registration No. 10288A on April 23, 2015, valid time is until April 23, 2018.</p>

4. CALIBRATION AND UNCERTAINTY

4.1. MEASURING INSTRUMENT CALIBRATION

The measuring equipment utilized to perform the tests documented in this report has been calibrated in accordance with the manufacturer's recommendations, and is traceable to recognized national standards.

4.2. MEASUREMENT UNCERTAINTY

Where relevant, the following measurement uncertainty levels have been estimated for tests performed on the apparatus:

PARAMETER	UNCERTAINTY
Bandwidth	1.1%
Peak Output Power(Conducted)(Spectrum analyzer)	0.86dB(10 MHz ≤ f < 3.6GHz);
	1.38dB(3.6GHz ≤ f < 8GHz)
Peak Output Power(Conducted)(Power Sensor)	0.74dB
Dwell Time	0.6%
Conducted spurious emissions	0.86dB(10 MHz ≤ f < 3.6GHz);
	1.40dB(3.6GHz ≤ f < 8GHz)
	1.66dB(8GHz ≤ f < 22GHz)
Uncertainty for radio frequency (RBW<20KHz)	3×10 ⁻⁸
Temperature	0.4°C
Humidity	2%
Uncertainty for Radiation Emission test (30MHz-1GHz)	4.70 dB (Antenna Polarize: V)
	4.84 dB (Antenna Polarize: H)
Uncertainty for Radiation Emission test (1GHz-18GHz)	4.10dB(1-6GHz)
	4.40dB (6GHz-18Gz)
Uncertainty for Power line conduction emission test	3.32dB (150KHz-30MHz)
Note: This uncertainty represents an expanded uncertainty expressed at approximately the 95% confidence level using a coverage factor of k=2.	

5. EQUIPMENT UNDER TEST

5.1. DESCRIPTION OF EUT

Equipment	4K IPTV Set Top Box	
Model Name	A12E	
Product Description	Operation Frequency	2402 MHz ~ 2480 MHz
	Modulation Type	Data Rate
	GFSK	1Mbps
	π/4-DQPSK	2Mbps
	8-DPSK	3Mbps
Battery	N/A	
Bluetooth Version	BT 4.0	
Adapter	Input: AC 100~240V, 50/60Hz, 0.5A Output: DC 12V, 1A	

5.2. MAXIMUM OUTPUT POWER

Frequency Range (MHz)	Number of Transmit Chains (NTX)	Bluetooth Mode	Frequency (MHz)	Channel Number	Max PK Conducted Power (dBm)
2400-2483.5	1	GFSK	2402-2480	0-78[79]	5.340
2400-2483.5	1	8-DPSK	2402-2480	0-78[79]	6.090

5.3. PACKET TYPE CONFIGURATION

Test Mode	Packet Type	Setting
GFSK	DH1	N/A
	DH3	N/A
	DH5	N/A
π/4-DQPSK	2-DH1	N/A
	2-DH3	N/A
	2-DH5	N/A
8-DPSK	3-DH1	N/A
	3-DH3	N/A
	3-DH5	N/A

5.4. CHANNEL LIST

Channel	Frequency (MHz)	Channel	Frequency (MHz)	Channel	Frequency (MHz)	Channel	Frequency (MHz)
00	2402	20	2422	40	2442	60	2462
01	2403	21	2423	41	2443	61	2463
02	2404	22	2424	42	2444	62	2464
03	2405	23	2425	43	2445	63	2465
04	2406	24	2426	44	2446	64	2466
05	2407	25	2427	45	2447	65	2467
06	2408	26	2428	46	2448	66	2468
07	2409	27	2429	47	2449	67	2469
08	2410	28	2430	48	2450	68	2470
09	2411	29	2431	49	2451	69	2471
10	2412	30	2432	50	2452	70	2472
11	2413	31	2433	51	2453	71	2473
12	2414	32	2434	52	2454	72	2474
13	2415	33	2435	53	2455	73	2475
14	2416	34	2436	54	2456	74	2476
15	2417	35	2437	55	2457	75	2477
16	2418	36	2438	56	2458	76	2478
17	2419	37	2439	57	2459	77	2479
18	2420	38	2440	58	2460	78	2480
19	2421	39	2441	59	2461		

5.5. TEST CHANNEL CONFIGURATION

Test Mode	Test Channel Number	Test Channel
GFSK	CH 00, CH 39, CH 78	Low, Middle, High
8-DPSK	CH 00, CH 39, CH 78	Low, Middle, High

note: only worse case is reported

5.6. THE WORSE CASE POWER SETTING PARAMETER

The Worse Case Power Setting Parameter under 2400 ~ 2483.5MHz Band				
Test Software Version		Bluetooth MP Test Tool		
Modulation Type	Transmit Antenna Number	Test Channel		
		CH 00	CH 39	CH 78
GFSK	1	default	default	default
8-DPSK	1	default	default	default

5.7. DESCRIPTION OF AVAILABLE ANTENNAS

Ant.	Frequency (MHz)	Antenna Type	Antenna Gain (dBi)
1	2402-2480	PCB Antenna	5

Test Mode	Transmit and Receive Mode	Description
GFSK	<input checked="" type="checkbox"/> 1TX, 1RX	Chain 1 can be used as transmitting/receiving antenna.
8-DPSK	<input checked="" type="checkbox"/> 1TX, 1RX	Chain 1 can be used as transmitting/receiving antenna.

5.8. WORST-CASE CONFIGURATIONS

Bluetooth Mode	Modulation Technology	Modulation Type	Data Rate (Mbps)
BR	FHSS	GFSK	1Mbit/s
EDR	FHSS	8-DPSK	3Mbit/s

5.9. DESCRIPTION OF TEST SETUP

SUPPORT EQUIPMENT

Item	Equipment	Brand Name	Model Name	Remarks
1	Laptop	ThinkPad	Latitude D610	N/A
2	LCD Monitor	DELL	S2440Lb	N/A

I/O CABLES

Cable No	Port	Connector Type	Cable Type	Cable Length(m)	Remarks
1	USB out 1	USB	Unshielded	0.50	N/A

ACCESSORY

Item	Accessory	Brand Name	Model Name	Description
1	Power Adapter	GIANTSUN	GSCU1000S012V15G	Input: AC 100~240V, 50/60Hz, 0.5A Output: DC 12V, 1A

TEST SETUP

The EUT can work in an engineer mode with a software through a Laptop.

SETUP DIAGRAM FOR TESTS

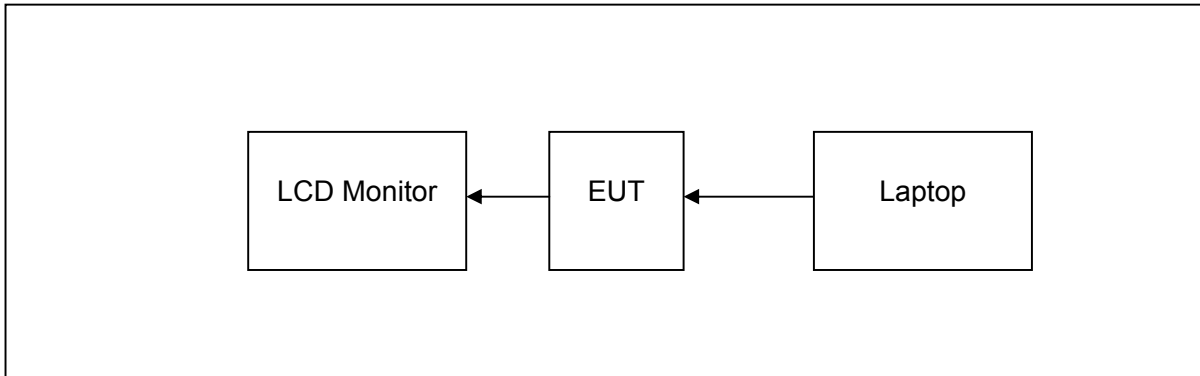

5.10. MEASURING INSTRUMENT AND SOFTWARE USED

Instrument (Conducted for RF Port)						
Used	Equipment	Manufacturer	Model No.	Serial No.	Last Cal.	Due. Date
<input checked="" type="checkbox"/>	Spectrum analyzer	R&S	FSU26	1166.1660.26	Oct. 16, 2016	Oct. 16, 2017
<input checked="" type="checkbox"/>	Wideband Radio Communication tester	R&S	CMW500	155523	Dec. 20, 2016	Dec. 20, 2017
<input checked="" type="checkbox"/>	Vector Signal Generator	Agilent	E8267D	MY52098743	Oct. 20, 2016	Oct. 20, 2017
<input checked="" type="checkbox"/>	Vector Signal Generator	Agilent	N5182A	MY48180737	Jul. 05, 2016	Jul. 05, 2017
<input checked="" type="checkbox"/>	Power Sensor	Agilent	U2021XA	MY55150010	Apr. 18, 2017	Apr. 18, 2018
<input checked="" type="checkbox"/>	Power Sensor	Agilent	U2021XA	MY55150011	Apr. 19, 2017	Apr. 19, 2018
<input checked="" type="checkbox"/>	DC Power Source	MATRIS	MPS-3005L-3	D813058W	Oct. 24, 2016	Oct. 24, 2017
<input checked="" type="checkbox"/>	Attenuator	Mini-Circuits	BW-S10W2	101109	Aug. 18, 2016	Aug. 18, 2017
<input checked="" type="checkbox"/>	RF Cable	Micable	C10-01-01-1	100309	Aug. 18, 2016	Aug. 18, 2017
<input checked="" type="checkbox"/>	Test Software	JS Tonscend	JS1120-2	Ver.2.5	N/A	N/A
<input checked="" type="checkbox"/>	USB Data acquisition	Agilent	U2531A	TW55043503	N/A	N/A
<input checked="" type="checkbox"/>	Auto control Unit	JS Tonscend	JS0806-2	158060010	N/A	N/A
Instrument (Radiated Tests)						
Used	Equipment	Manufacturer	Model No.	Serial No.	Last Cal.	Expired date
<input checked="" type="checkbox"/>	EMI Test Receiver	R&S	ESU8	100316	Oct. 16, 2016	Oct. 16, 2017
<input checked="" type="checkbox"/>	PSA Series Spectrum analyzer	Agilent	E4447A	MY5018003 1	Jul. 06, 2016	Jul. 06, 2017
<input checked="" type="checkbox"/>	Trilog Broadband Antenna	Schwarzbeck	VULB9163	9163-462	Oct. 27, 2016	Oct. 27, 2017
<input checked="" type="checkbox"/>	Active Loop antenna	Schwarzbeck	FMZB-1519	1519-038	Oct. 27, 2016	Oct. 27, 2017
<input checked="" type="checkbox"/>	Double Ridged Horn Antenna	R&S	HF907	100276	Oct. 12, 2016	Oct. 12, 2017
<input checked="" type="checkbox"/>	Horn Antenna	ETS-LINDGREN	3160-09	SEL0076	Oct. 16, 2016	Oct. 16, 2017
<input checked="" type="checkbox"/>	Pre-amplifier	A.H.	PAM-0118	360	Oct. 16, 2016	Oct. 16, 2017
<input checked="" type="checkbox"/>	Pre-amplifier	Compliance Directions Systems Inc.	PAP-1G26-48	6279.628	Oct. 16, 2016	Oct. 16, 2017

<input checked="" type="checkbox"/>	RF Cable	HUBSER	CP-X2	W11.03	Oct. 16, 2016	Oct. 16, 2017
<input checked="" type="checkbox"/>	RF Cable	HUBSER	CP-X1	W12.02	Oct. 16, 2016	Oct. 16, 2017
<input checked="" type="checkbox"/>	MI Cable	HUBSER	C10-01-01-1M	1091629	Oct. 16, 2016	Oct. 16, 2017
<input checked="" type="checkbox"/>	Test software	Audix	E3	V 6.11111b	N/A	N/A
Instrument (Line Conducted Emission (AC Main))						
Used	Equipment	Manufacturer	Model No.	Serial No.	Last Cal.	Expired date
<input checked="" type="checkbox"/>	Test Receiver	R&S	ESU8	100316	Oct.16, 2016	Oct.16, 2017
<input checked="" type="checkbox"/>	LISN 1	R&S	ENV216	101109	Oct.16, 2016	Oct.16, 2017
<input checked="" type="checkbox"/>	LISN 2	R&S	ESH2-Z5	100309	Oct.16, 2016	Oct.16, 2017
<input checked="" type="checkbox"/>	Pulse Limiter	R&S	ESH3-Z2	101242	Oct.16, 2016	Oct.16, 2017
<input checked="" type="checkbox"/>	CE Cable 1	HUBSER	ESU8/RF2	W10.01	Oct.16, 2016	Oct.16, 2017
<input checked="" type="checkbox"/>	Test software	Audix	E3	V 6.11111b	N/A	N/A

6. MEASUREMENT METHODS

No.	Test Item	KDB Name
1	20 dB Bandwidth	FCC Public Notice DA 00-705
2	99% Bandwidth	ANSI C63.10-2013
3	Peak Output Power	FCC Public Notice DA 00-705
4	Power Spectral Density	FCC Public Notice DA 00-705
5	Out-of-band emissions in non-restricted bands	FCC Public Notice DA 00-705
6	Out-of-band emissions in restricted bands	FCC Public Notice DA 00-705
7	Band-edge	FCC Public Notice DA 00-705

ANTENNA PORT TEST RESULTS

6.1. 20 dB BANDWIDTH AND 99% BANDWIDTH

LIMITS

FCC Part15 (15.247) , Subpart C IC RSS-247 ISSUE 1			
Section	Test Item	Limit	Frequency Range (MHz)
FCC 15.247 (a) (1) IC RSS-247 Clause 5.1 (1)	20dB Bandwidth	N/A	2400-2483.5
RSS-Gen Clause 4.4.1	99% Bandwidth	N/A	2400-2483.5

TEST PROCEDURE

Connect the UUT to the spectrum analyser and use the following settings:

Center Frequency	The centre frequency of the channel under test
Detector	Peak
RBW	$\geq 1\%$ of the 20 dB bandwidth
VBW	\geq RBW
Trace	Max hold
Sweep	Auto couple

Allow the trace to stabilize and measure the maximum width of the emission that is constrained by the frequencies associated with the two outermost amplitude points (upper and lower frequencies) that are attenuated by 20 dB relative to the maximum level measured in the fundamental emission.

TEST SETUP

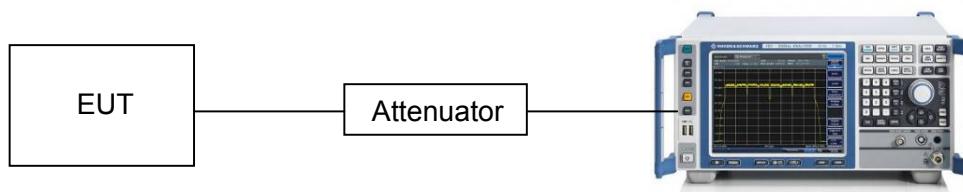

TEST CONDITIONS

Temperature: 24.6° C
 Relative Humidity: 58%
 Test Voltage: AC 120V/60Hz

RESULTS

Mode	Channel.	20dB Bandwidth [MHz]	99% OBW [MHz]	Verdict
GFSK	LCH	1.112	0.972	PASS
GFSK	MCH	1.118	0.972	PASS
GFSK	HCH	1.114	0.968	PASS
8-DPSK	LCH	1.388	1.218	PASS
8-DPSK	MCH	1.396	1.220	PASS
8-DPSK	HCH	1.392	1.218	PASS

Test Graph

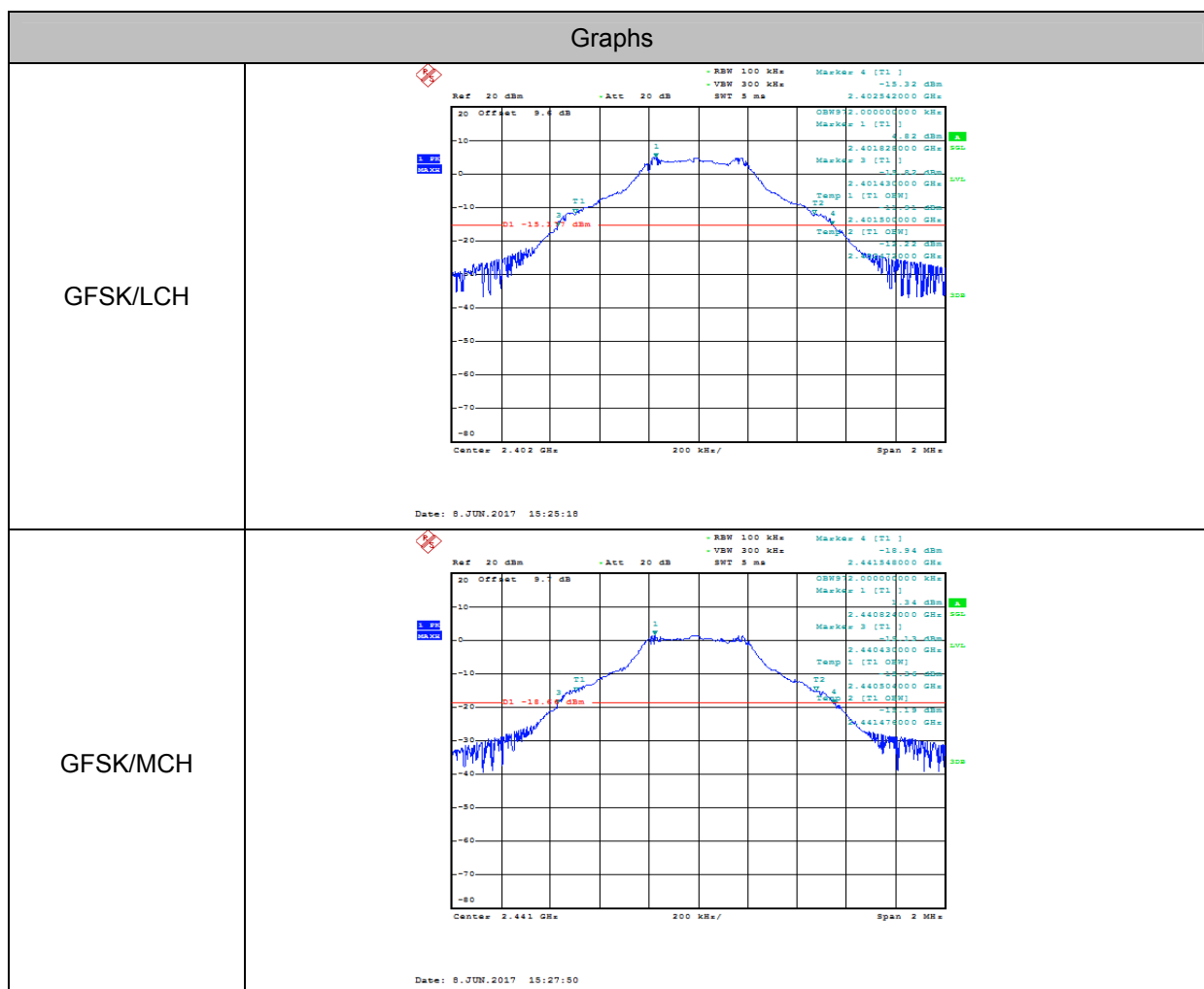

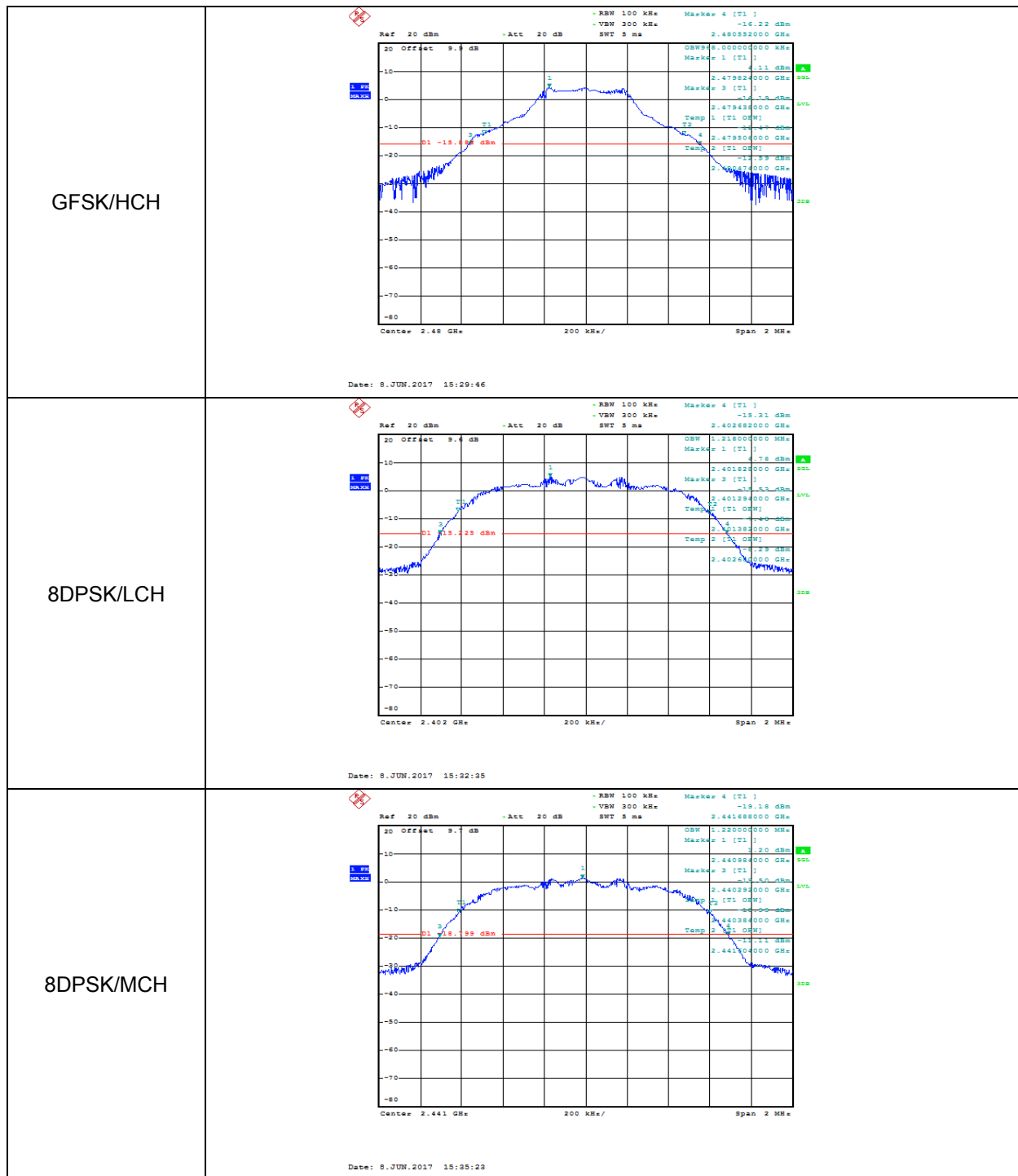

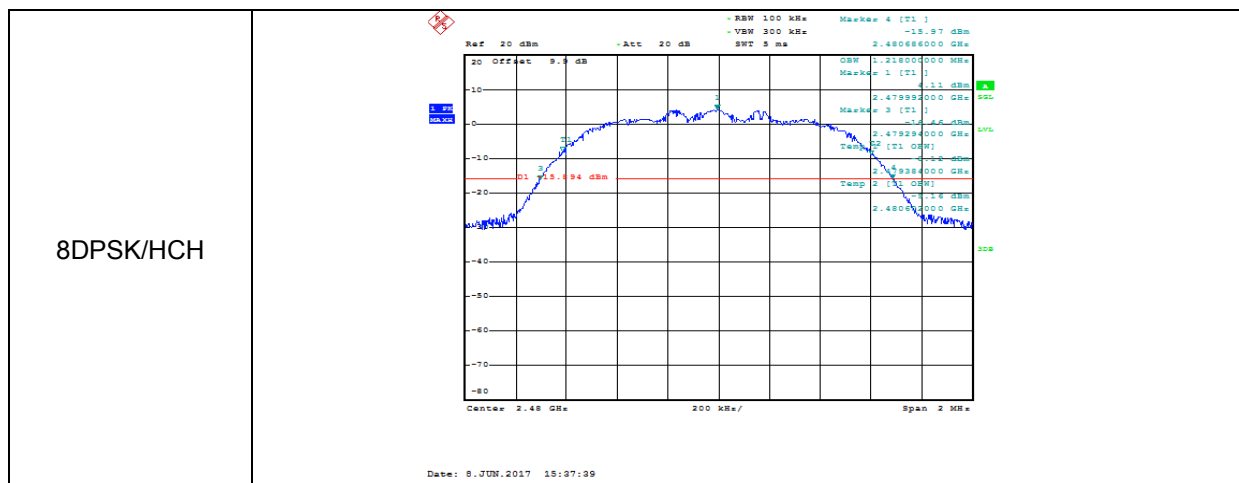

6.2. PEAK CONDUCTED OUTPUT POWER

LIMITS

FCC Part15 (15.247) , Subpart C IC RSS-247 ISSUE 1			
Section	Test Item	Limit	Frequency Range (MHz)
FCC 15.247 (b) (1) IC RSS-247 Clause 5.4 (2)	Peak Conducted Output Power	1 watt or 30dBm	2400-2483.5

TEST PROCEDURE

Connect the UUT to the spectrum analyser and use the following settings:

Center Frequency	The centre frequency of the channel under test
Detector	Peak
RBW	> the 20 dB bandwidth of the emission being measured (e.g. 1 MHz for BT)
VBW	≥RBW
Span	approximately 5 times the 20 dB bandwidth, centered on a hopping channel
Trace	Max hold
Sweep time	Auto couple

Allow trace to fully stabilize and use peak marker function to determine the peak amplitude level.

TEST SETUP

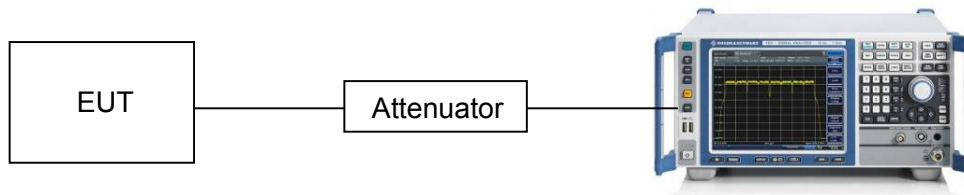

TEST CONDITIONS

Temperature: 24.6° C
Relative Humidity: 58%
Test Voltage: AC 120V/60Hz

RESULTS

Mode	Channel.	Maximum Peak Output Power [dBm]	Verdict
GFSK	LCH	5.340	PASS
GFSK	MCH	1.980	PASS
GFSK	HCH	4.820	PASS
8-DPSK	LCH	6.090	PASS
8-DPSK	MCH	2.790	PASS
8-DPSK	HCH	5.680	PASS

6.3. CARRIER HOPPING CHANNEL SEPARATION

LIMITS

FCC Part15 (15.247) , Subpart C IC RSS-247 ISSUE 1			
Section	Test Item	Limit	Frequency Range (MHz)
FCC 15.247 (a) (1) IC RSS-247 Clause 5.1 (2)	Carrier Hopping Channel Separation	25 kHz or two-thirds of the 20 dB bandwidth of the hopping channel, whichever is greater.	2400-2483.5

TEST PROCEDURE

Connect the UUT to the spectrum analyser and use the following settings:

Center Frequency	The centre frequency of the channel under test
Span	wide enough to capture the peaks of two adjacent channels
Detector	Peak
RBW	$\geq 1\%$ of the span
VBW	\geq RBW
Trace	Max hold
Sweep time	Auto couple

Allow the trace to stabilize. Use the marker-delta function to determine the separation between the peaks of the adjacent channels. The limit is specified in one of the subparagraphs of this Section. Submit this plot.

TEST SETUP

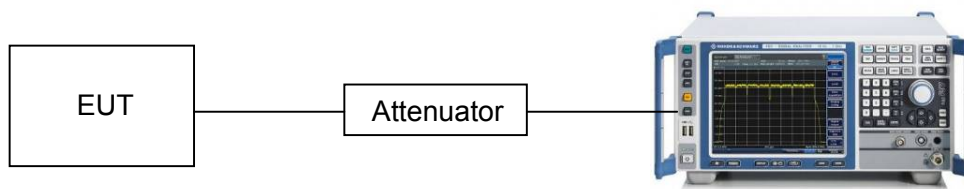

TEST CONDITIONS

Temperature: 24.6°C
 Relative Humidity: 58%
 Test Voltage: AC 120V/60Hz

RESULTS

Mode	Channel.	Carrier Frequency Separation [MHz]	Verdict
GFSK	MCH	1.002	PASS
8-DPSK	MCH	1.004	PASS

Test Graph

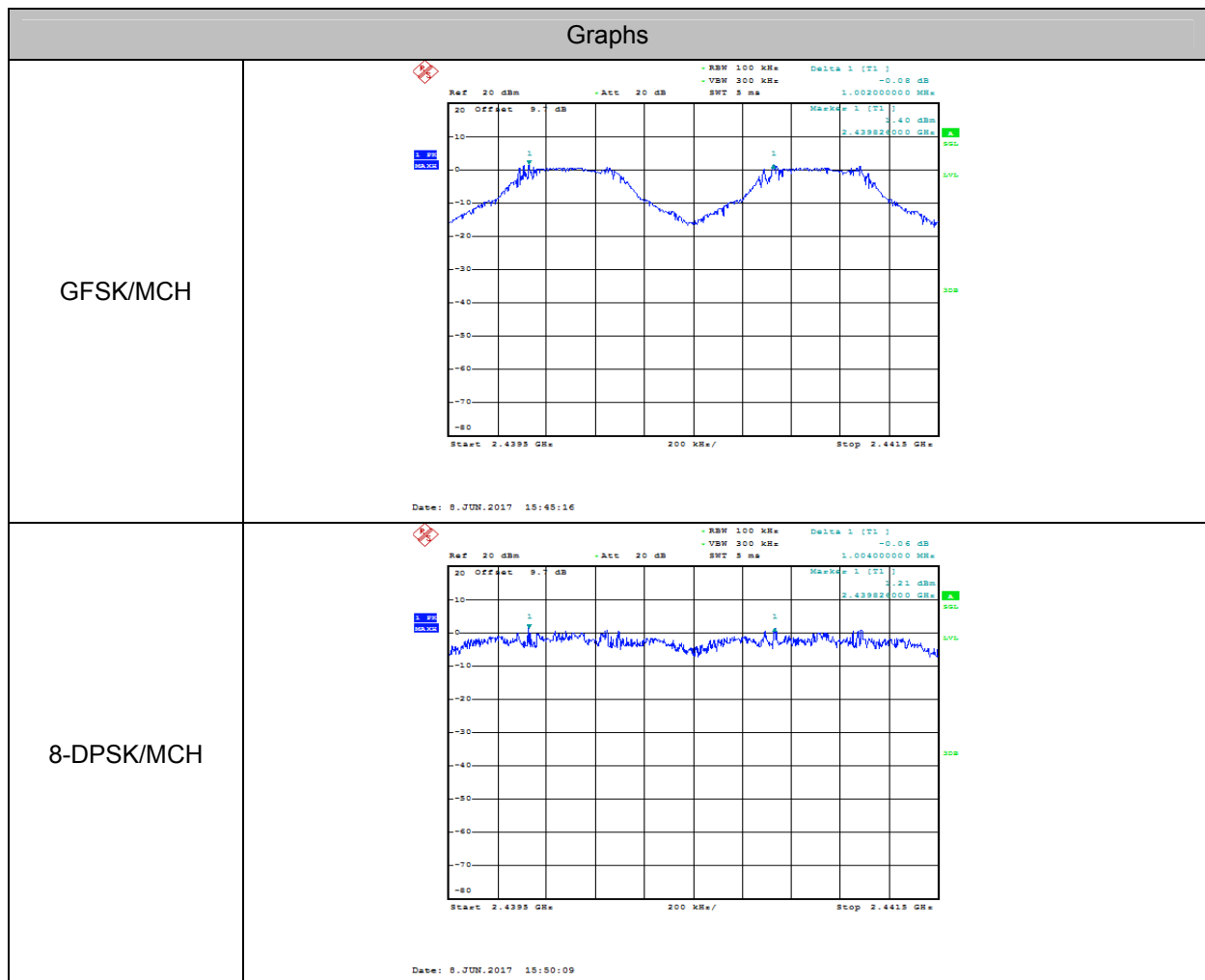

6.4. NUMBER OF HOPPING FREQUENCY

LIMITS

FCC Part15 (15.247) , Subpart C IC RSS-247 ISSUE 1		
Section	Test Item	Limit
15.247 (a) (1) III IC RSS-247 Clause 5.1 (4)	Number of Hopping Frequency	at least 15 hopping channels

TEST PROCEDURE

Connect the EUT to the spectrum analyser and use the following settings:

Detector	Peak
RBW	1% of the span
VBW	≥RBW
Span	The frequency band of operation
Trace	Max hold
Sweep time	Auto couple

Set EUT to transmit maximum output power and switch on frequency hopping function. then set enough count time (larger than 5000 times) to get all the hopping frequency channel displayed on the screen of spectrum analyzer.

Count the quantity of peaks to get the number of hopping channels.

TEST SETUP

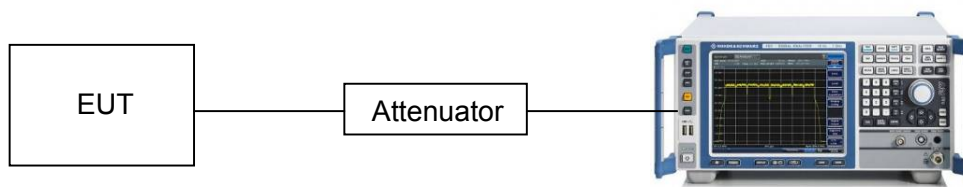

TEST CONDITIONS

Temperature: 24.6° C
 Relative Humidity: 58%
 Test Voltage: AC 120V/60HZ

RESULTS

Mode	Channel.	Number of Hopping Channel	Verdict
GFSK	Hop	79	PASS
8-DPSK	Hop	79	PASS

Test Graph

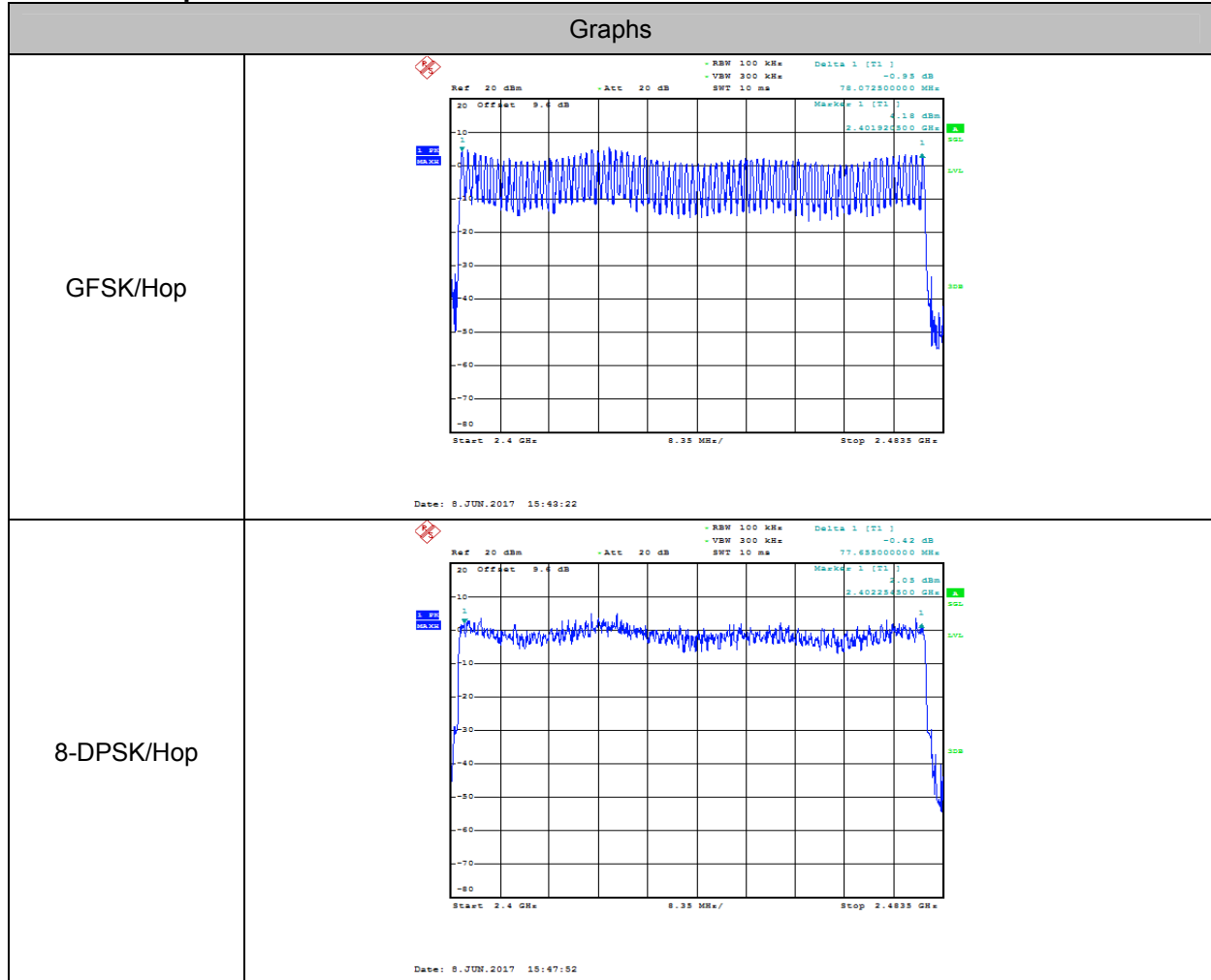

6.5. TIME OF OCCUPANCY (DWELL TIME)

LIMITS

FCC Part15 (15.247) , Subpart C IC RSS-247 ISSUE 1		
Section	Test Item	Limit
15.247 (a) (1) III IC RSS-247 Clause 5.1 (4)	Time of Occupancy (Dwell Time)	The average time of occupancy on any channel shall not be greater than 0.4 seconds within a period of 0.4 seconds, multiplied by the number of hopping channels employed.

TEST PROCEDURE

Connect the UUT to the spectrum analyser and use the following settings:

Center Frequency	The centre frequency of the channel under test
Detector	Peak
RBW	1 MHz
VBW	≥RBW
Span	zero span
Trace	Max hold
Sweep time	As necessary to capture the entire dwell time per hopping channel

- a. The transmitter output (antenna port) was connected to the spectrum analyzer
- b. Set RBW of spectrum analyzer to 1MHz and VBW to 1MHz.
- c. Use a video trigger with the trigger level set to enable triggering only on full pulses.
- d. Sweep Time is more than once pulse time.
- e. Set the center frequency on any frequency would be measure and set the frequency span to zero span.
- f. Measure the maximum time duration of one single pulse.
- g. Set the EUT for DH5, DH3 and DH1 packet transmitting.
- h. Measure the maximum time duration of one single pulse.
 - A Period Time = (channel number)*0.4
 - DH1 Time Slot: Reading * (1600/2)*31.6/(channel number)
 - DH3 Time Slot: Reading * (1600/4)*31.6/(channel number)
 - DH5 Time Slot: Reading * (1600/6)*31.6/(channel number)

TEST SETUP

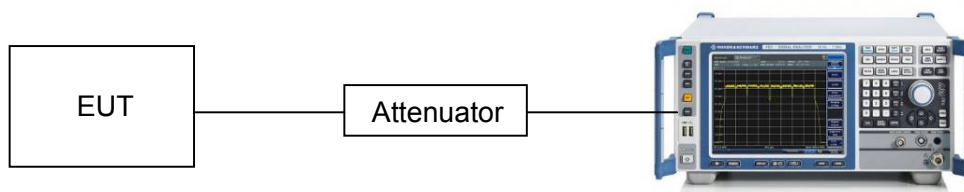

TEST CONDITIONS

Temperature: 24.6°C
 Relative Humidity: 58%
 Test Voltage: AC 120V/60Hz

RESULTS

Mode	Packet	Channel	Burst Width [ms/hop/ch]	Total Hops[hop*ch]	Dwell Time[s]	Verdict
Tx mode	DH1	MCH	0.38	320	0.122	PASS
Tx mode	DH3	MCH	1.64	160	0.262	PASS
Tx mode	DH5	MCH	2.88	106.7	0.307	PASS
Tx mode	3DH1	MCH	0.39	320	0.125	PASS
Tx mode	3DH3	MCH	1.64	160	0.262	PASS
Tx mode	3DH5	MCH	2.88	106.7	0.307	PASS

Test Graph

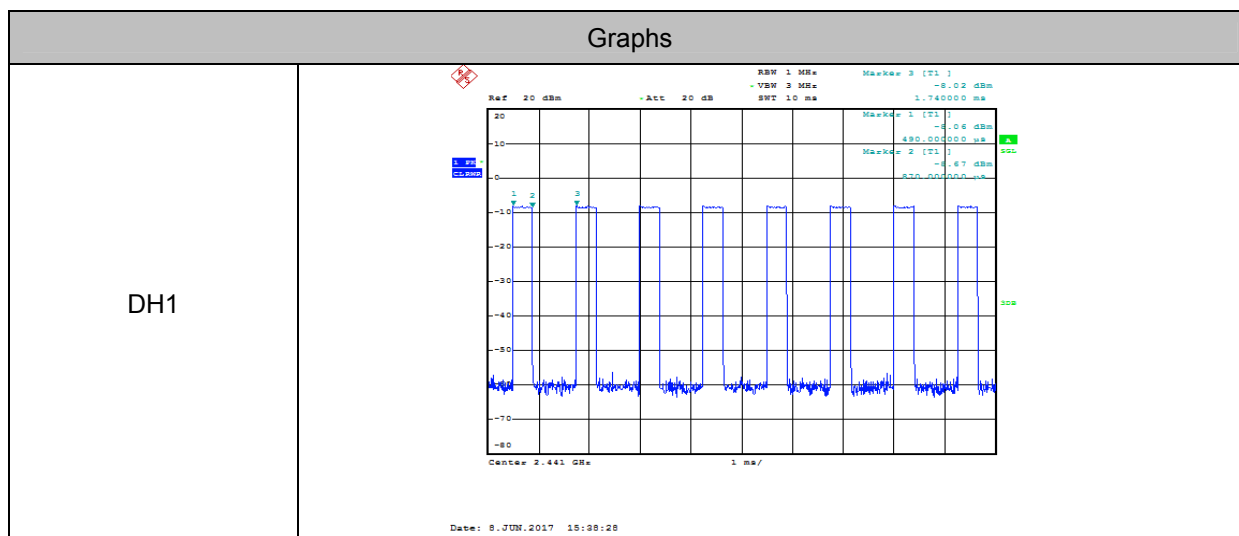

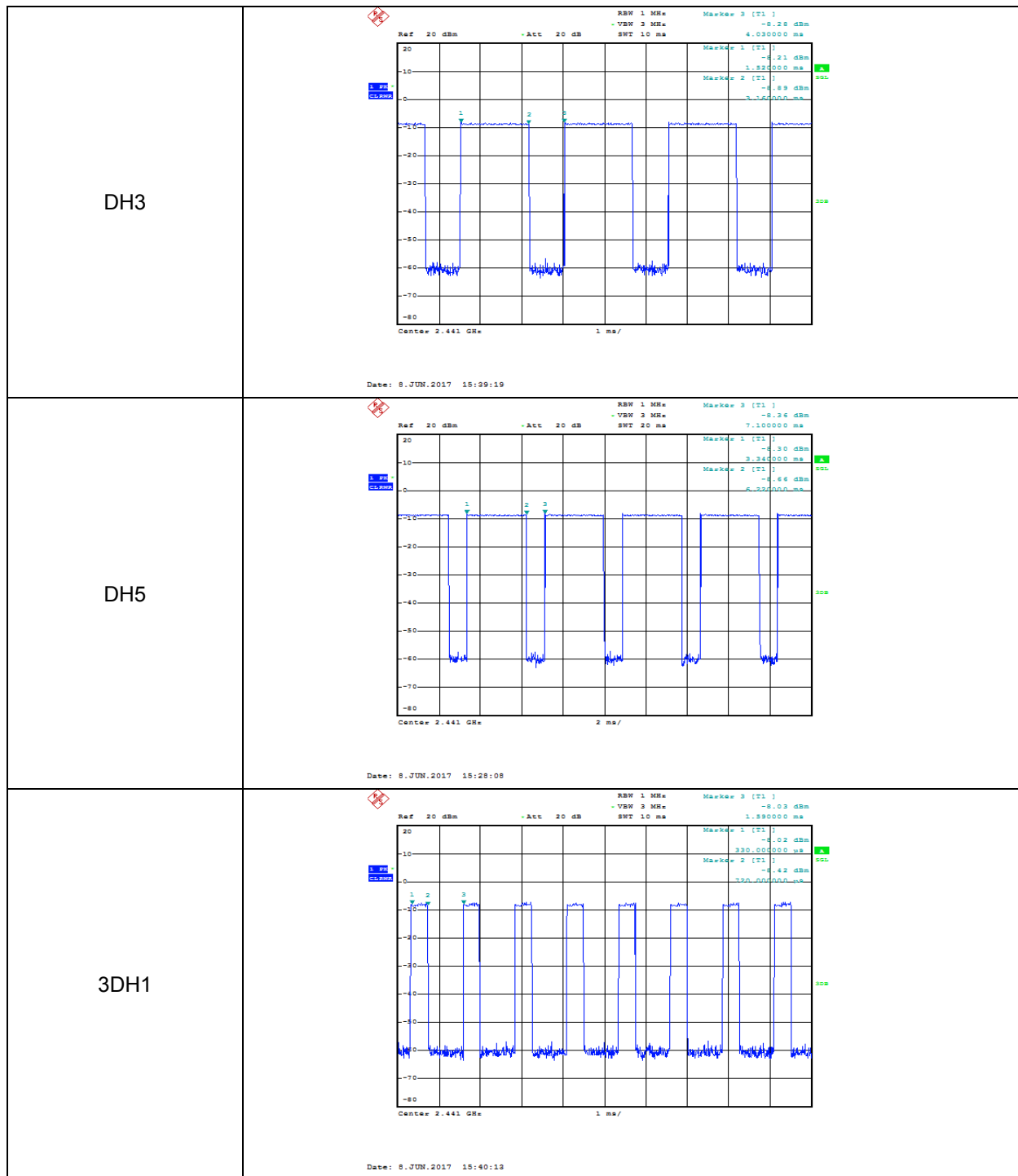

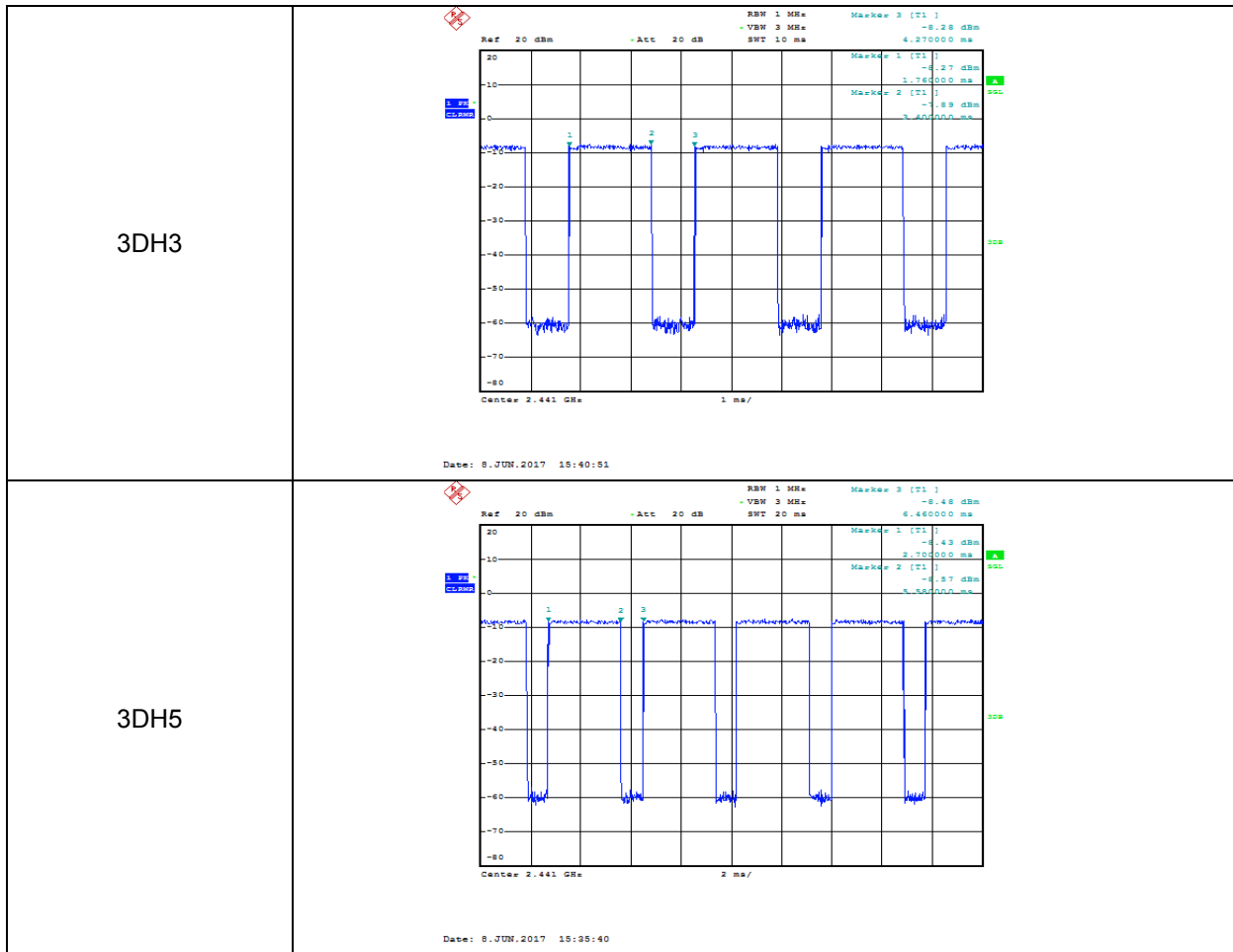

6.6. CONDUCTED BANDEGE AND SPURIOUS EMISSIONS

LIMITS

FCC Part15 (15.247) , Subpart C IC RSS-247 ISSUE 1		
Section	Test Item	Limit
FCC §15.247 (d) IC RSS-247 5.5	Conducted Bandedge and Spurious Emissions	at least 20 dB below that in the 100 kHz bandwidth within the band that contains the highest level of the desired power

TEST PROCEDURE

Connect the UUT to the spectrum analyser and use the following settings:

Center Frequency	The centre frequency of the channel under test
Detector	Peak
RBW	100K
VBW	$\geq 3 \times \text{RBW}$
Span	1.5 x DTS bandwidth
Trace	Max hold
Sweep time	Auto couple

Use the peak marker function to determine the maximum PSD level.

Span	Set the center frequency and span to encompass frequency range to be measured
Detector	Peak
RBW	100K
VBW	$\geq 3 \times \text{RBW}$
measurement points	$\geq \text{span}/\text{RBW}$
Trace	Max hold
Sweep time	Auto couple.

Use the peak marker function to determine the maximum amplitude level.

TEST SETUP

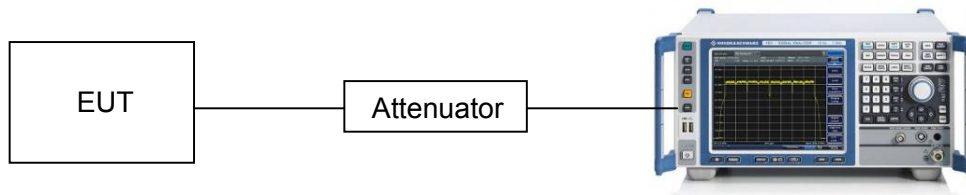

TEST CONDITIONS

Temperature: 24.6° C
 Relative Humidity: 58%
 Test Voltage: AC 120V/60Hz

RESULTS

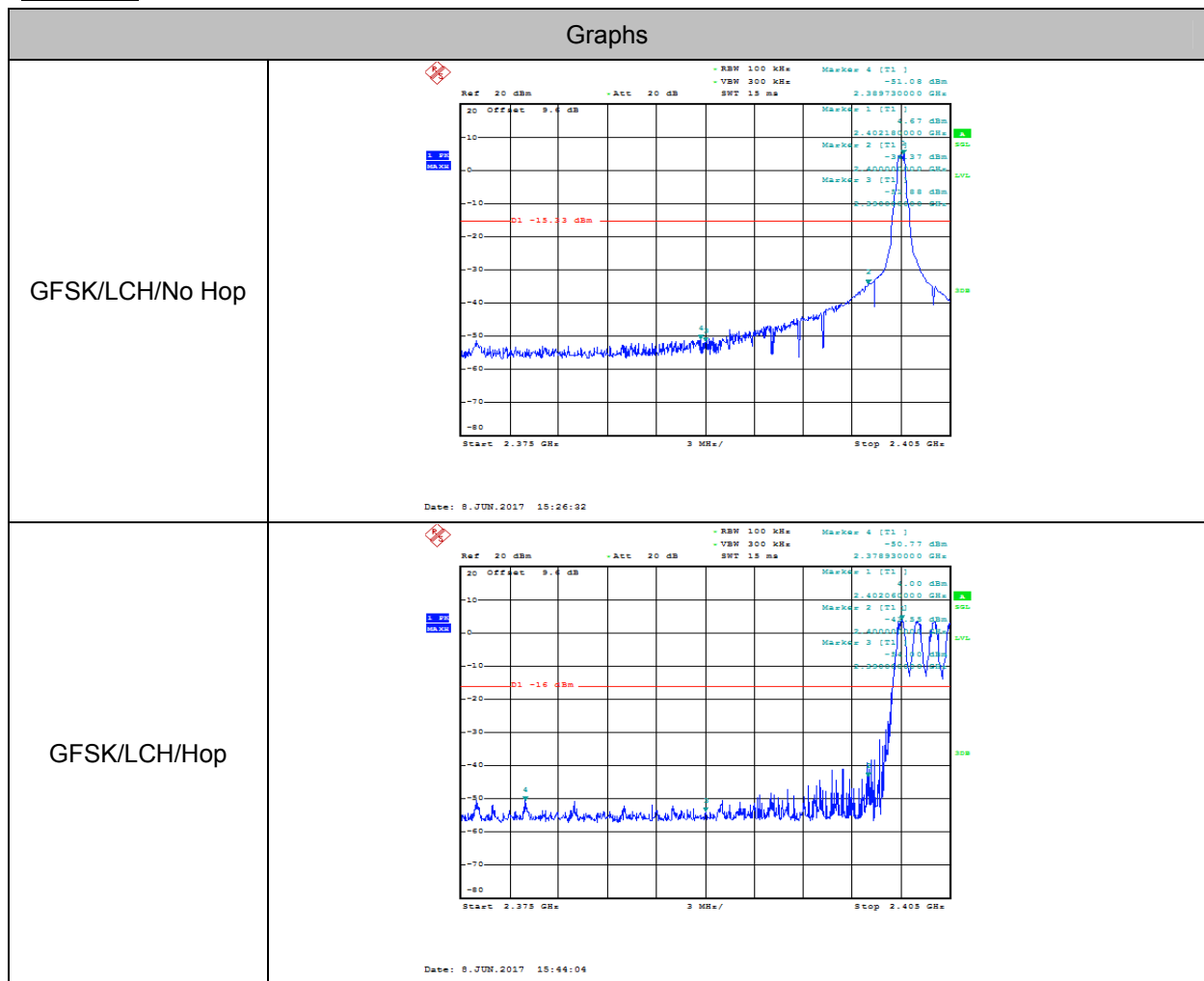

<p>GFSK/HCH/No Hop</p>	<p>Date: 8 JUN 2017 15:31:22</p>
<p>GFSK/HCH/Hop</p>	<p>Date: 8 JUN 2017 15:45:57</p>
<p>8DPSK/LCH/No Hop</p>	<p>Date: 8 JUN 2017 15:33:49</p>

<p>8DPSK/LCH/Hop</p>	<p>Date: 8 JUN 2017 15:48:33</p>
<p>8DPSK/HCH/No Hop</p>	<p>Date: 8 JUN 2017 15:37:17</p>
<p>8DPSK/HCH/Hop</p>	<p>Date: 8 JUN 2017 15:50:59</p>

7. RADIATED TEST RESULTS

7.1. LIMITS AND PROCEDURE

LIMITS

Please refer to FCC §15.205 and §15.209

Please refer to IC RSS-GEN Clause 8.9 (Transmitter)

Radiation Disturbance Test Limit for FCC (Class B)(9KHz-1GHz)

Frequency (MHz)	Field Strength (microvolts/meter)	Measurement Distance (meters)
0.009~0.490	2400/F(KHz)	300
0.490~1.705	24000/F(KHz)	30
1.705~30.0	30	30
30~88	100	3
88~216	150	3
216~960	200	3
960~1000	500	3

Radiation Disturbance Test Limit for FCC (Above 1G)

Frequency (MHz)	dB(uV/m) (at 3 meters)	
	Peak	Average
Above 1000	74	54

TEST CONDITIONS

Temperature: 22.2°C

Relative Humidity: 61.2%

Test Voltage: AC 120V/60Hz

TEST SETUP AND PROCEDURE

Below 30MHz

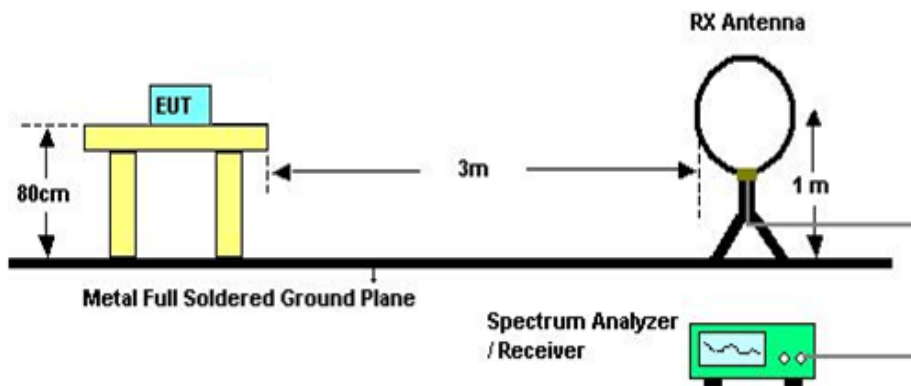

The setting of the spectrum analyser

RBW	200Hz (From 9kHz to 0.15MHz)/ 9KHz (From 0.15MHz to 30MHz)
VBW	200Hz (From 9kHz to 0.15MHz)/ 9KHz (From 0.15MHz to 30MHz)
Sweep	Auto
Detector	Peak/QP/ Average
Trace	Max hold

1. The testing follows the guidelines in ANSI C63.10-2013
2. The EUT was arranged to its worst case and then turntable (from 0 degree to 360 degrees) to find the maximum reading. A pre-amp and a high pass filter are used for the test in order to get better signal level. Both horizontal and vertical polarizations of the antenna are set to make the measurement.
3. The EUT was placed on a turntable with 0.8 meter above ground.
4. The EUT was set 3 meters from the interference receiving antenna, which was mounted on the top of a variable height antenna tower.
5. Corrected Reading: Antenna Factor + Cable Loss + Read Level - Preamp Factor = Level
6. For measurement below 1GHz, the initial step in collecting conducted emission data is a spectrum analyzer peak detector mode pre-scanning the measurement frequency range. Significant peaks are then marked and then Quasi Peak detector mode re-measured. If the emission level of the EUT measured by the peak detector is 3 dB lower than the applicable limit, the peak emission level will be reported. Otherwise, the emission measurement will be repeated using the quasi-peak detector and reported.
7. For the actual test configuration, please refer to the related item in this test report (Photographs of the Test Configuration)

Below 1G

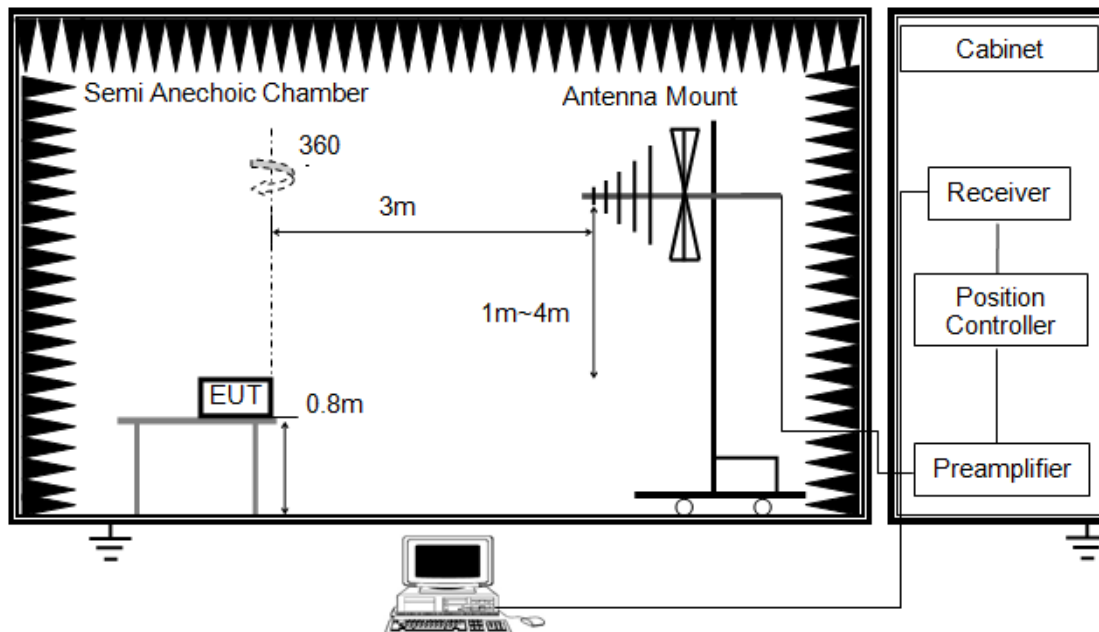

The setting of the spectrum analyser

RBW	120K
VBW	300K
Sweep	Auto
Detector	Peak/QP
Trace	Max hold

1. The testing follows the guidelines in ANSI C63.10-2013.
2. The EUT was arranged to its worst case and then tune the antenna tower (from 1 m to 4 m) and turntable (from 0 degree to 360 degrees) to find the maximum reading. A pre-amp and a high pass filter are used for the test in order to get better signal level. Both horizontal and vertical polarizations of the antenna are set to make the measurement.
3. The EUT was placed on a turntable with 0.8 meter above ground.
4. The EUT was set 3 meters from the interference receiving antenna, which was mounted on the top of a variable height antenna tower.
5. Corrected Reading: $\text{Antenna Factor} + \text{Cable Loss} + \text{Read Level} - \text{Preamp Factor} = \text{Level}$
6. For measurement below 1GHz, the initial step in collecting conducted emission data is a spectrum analyzer peak detector mode pre-scanning the measurement frequency range. Significant peaks are then marked and then Quasi Peak detector mode re-measured. If the emission level of the EUT measured by the peak detector is 3 dB lower than the applicable limit, the peak emission level will be reported. Otherwise, the emission measurement will be repeated using the quasi-peak detector and reported.
7. For the actual test configuration, please refer to the related Item in this test report (Photographs of the Test Configuration)

ABOVE 1G

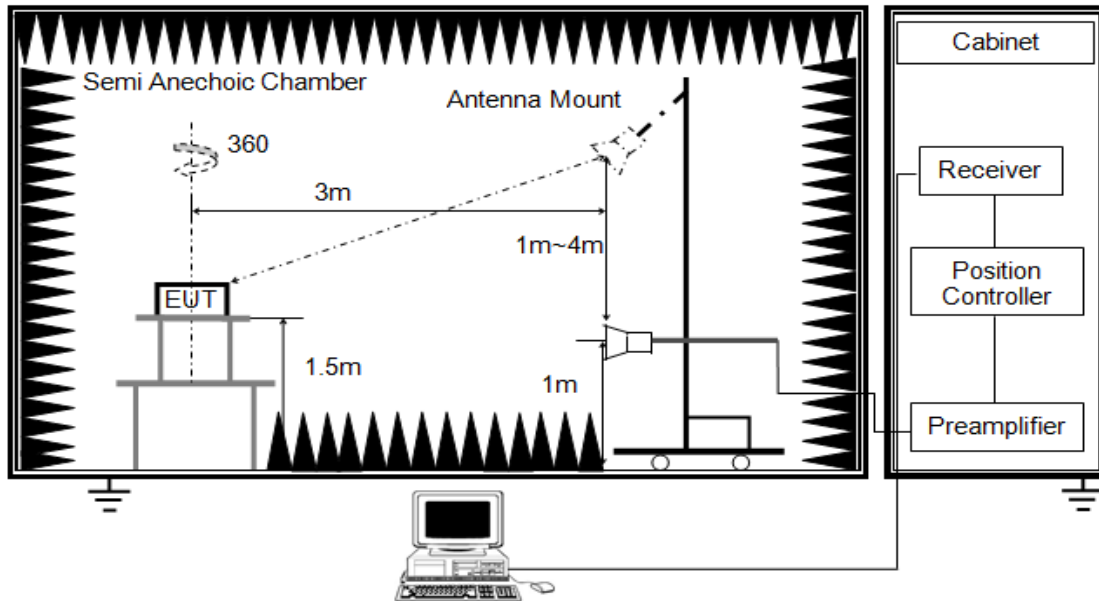

The setting of the spectrum analyser

RBW	1M
VBW	3M
Sweep	Auto
Detector	Peak and CISPR Average
Trace	Max hold

1. The testing follows the guidelines in ANSI C63.10-2013.
2. The EUT was arranged to its worst case and then tune the antenna tower (1.5 m) and turntable (from 0 degree to 360 degrees) to find the maximum reading. A pre-amp and a high pass filter are used for the test in order to get better signal level. Both horizontal and vertical polarizations of the antenna are set to make the measurement.
3. The EUT was placed on a turntable with 1.5 meter above ground.
4. The EUT was set 3 meters from the interference receiving antenna, which was mounted on the top of a variable height antenna tower.
5. Corrected Reading: Antenna Factor + Cable Loss + Read Level - Preamp Factor = Level
6. For measurement above 1GHz, the emission measurement will be measured by the peak detector and the AV detector.
7. For the actual test configuration, please refer to the related Item in this test report (Photographs of the Test Configuration)

TEST CONDITIONS

Temperature: 22.2°C
 Relative Humidity: 61%
 Test Voltage: AC 120V/60Hz

7.2. RESTRICTED BANDEDGE

7.2.1. GFSK MODE

RESTRICTED BANDEDGE (LOW CHANNEL, HORIZONTAL)

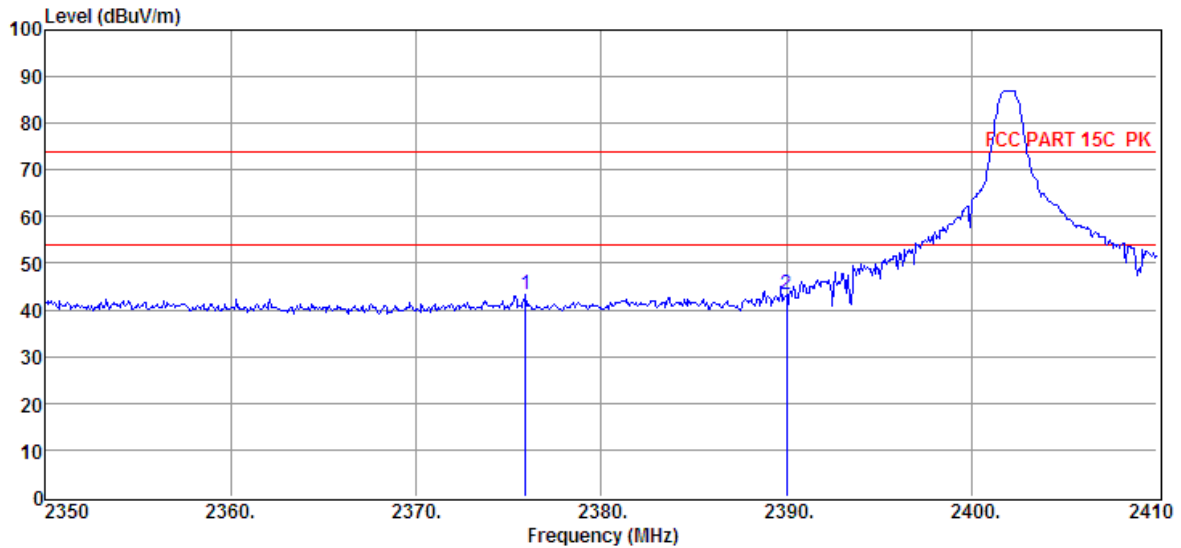

Item (Mark)	Freq. (MHz)	Read Level (dB μ V)	Antenna Factor (dB/m)	PRM Facto r dB	Cable Loss dB	Result Level (dB μ V/m)	Limit Line (dB μ V/m)	Over Limit (dB)	Detector	Polarization
1	2375.92	36.82	29.72	29.39	6.01	43.16	74.00	-30.84	Peak	HORIZONTAL
2	2390.00	37.07	29.78	29.42	6.03	43.46	74.00	-30.54	Peak	HORIZONTAL

RESTRICTED BANDEDGE (LOW CHANNEL, VERTICAL)

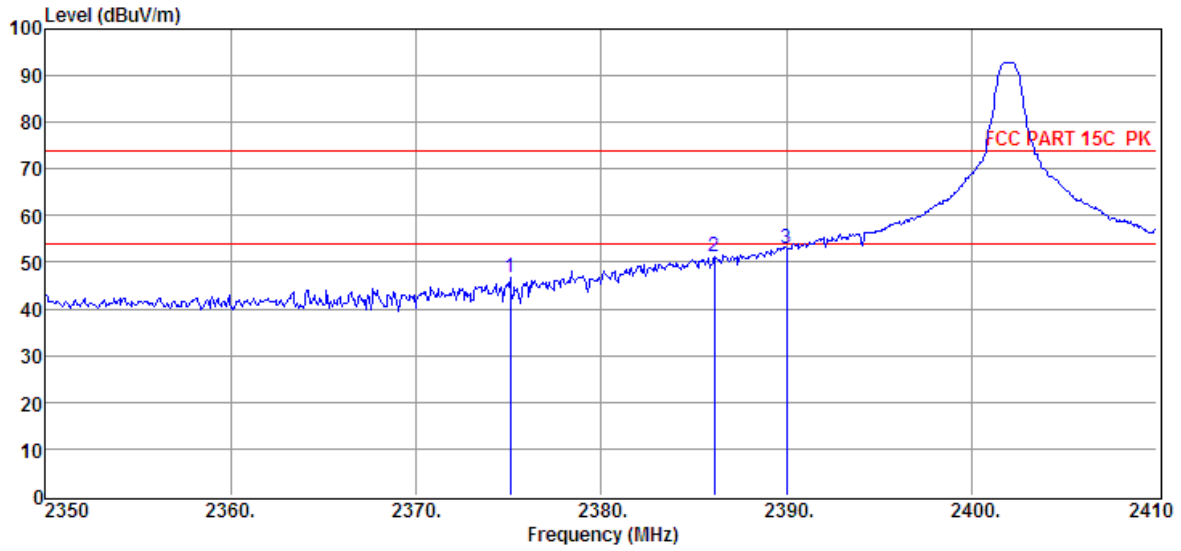

Item (Mark)	Freq. (MHz)	Read Level (dBμV)	Antenna Factor (dB/m)	PRM Facto r dB	Cable Loss dB	Result Level (dBμV/m)	Limit Line (dBμV/m)	Over Limit (dB)	Detector	Polarization
1	2375.08	40.51	29.72	29.39	6.01	46.85	74.00	-27.15	Peak	VERTICAL
2	2386.12	44.70	29.76	29.41	6.01	51.06	74.00	-22.94	Peak	VERTICAL
3	2390.00	46.65	29.78	29.42	6.03	53.04	74.00	-20.96	Peak	VERTICAL

RESTRICTED BANDEDGE (HIGH CHANNEL, HORIZONTAL)

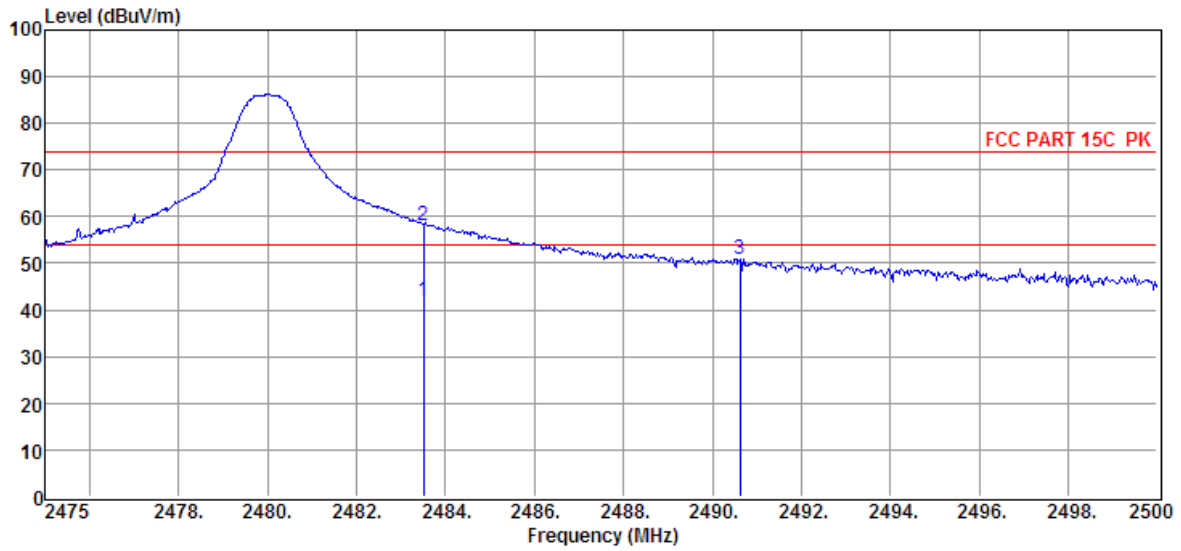

Item (Mark)	Freq. (MHz)	Read Level (dBμV)	Antenna Factor (dB/m)	PRM Facto r dB	Cable Loss dB	Result Level (dBμV/m)	Limit Line (dBμV/m)	Over Limit (dB)	Detector	Polarization
1	2483.50	35.23	30.14	29.71	6.13	41.79	54.00	-12.21	Average	HORIZONTAL
2	2483.50	51.47	30.14	29.71	6.13	58.03	74.00	-15.97	Peak	HORIZONTAL
3	2490.63	44.34	30.16	29.71	6.17	50.96	74.00	-23.04	Peak	HORIZONTAL

RESTRICTED BANDEDGE (HIGH CHANNEL, VERTICAL)

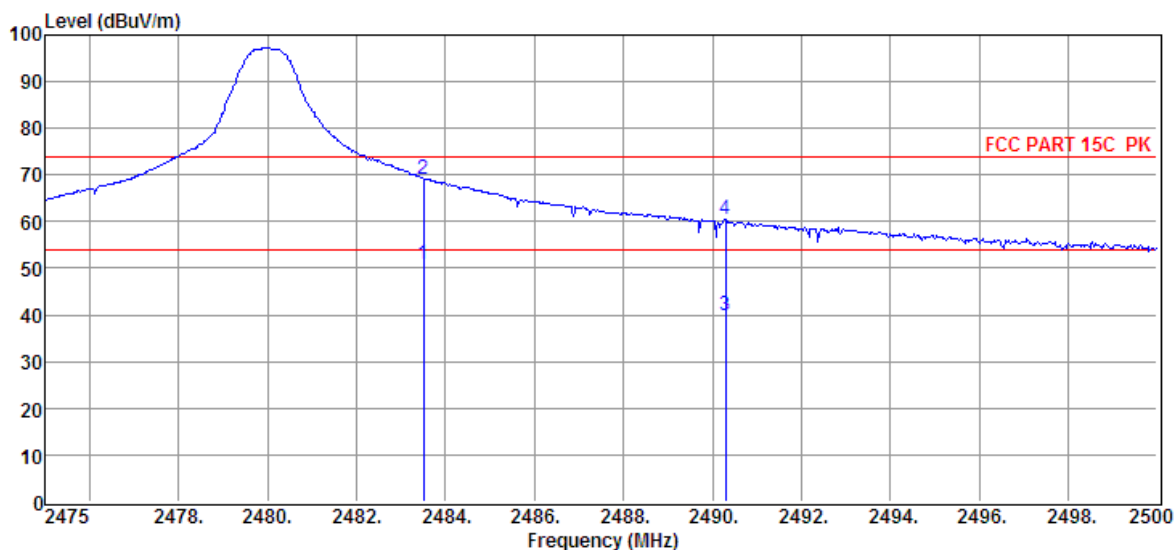

Item (Mark)	Freq. (MHz)	Read Level (dB μ V)	Antenna Factor (dB/m)	PRM Factor (dB)	Cable Loss (dB)	Result Level (dB μ V/m)	Limit Line (dB μ V/m)	Over Limit (dB)	Detector	Polarization
1	2483.50	44.20	30.14	29.71	6.13	50.76	54.00	-3.24	Average	VERTICAL
2	2483.50	62.67	30.14	29.71	6.13	69.23	74.00	-4.77	Peak	VERTICAL
3	2490.30	33.25	30.16	29.71	6.17	39.87	54.00	-14.13	Average	VERTICAL
4	2490.30	53.77	30.16	29.71	6.17	60.39	74.00	-13.61	Peak	VERTICAL

Note: EUT in each of three orthogonal axis emissions had been tested, but only the worst case (X axis) data recorded in the report.

7.2.2. 8-DPSK MODE

RESTRICTED BANDEDGE (LOW CHANNEL, HORIZONTAL)

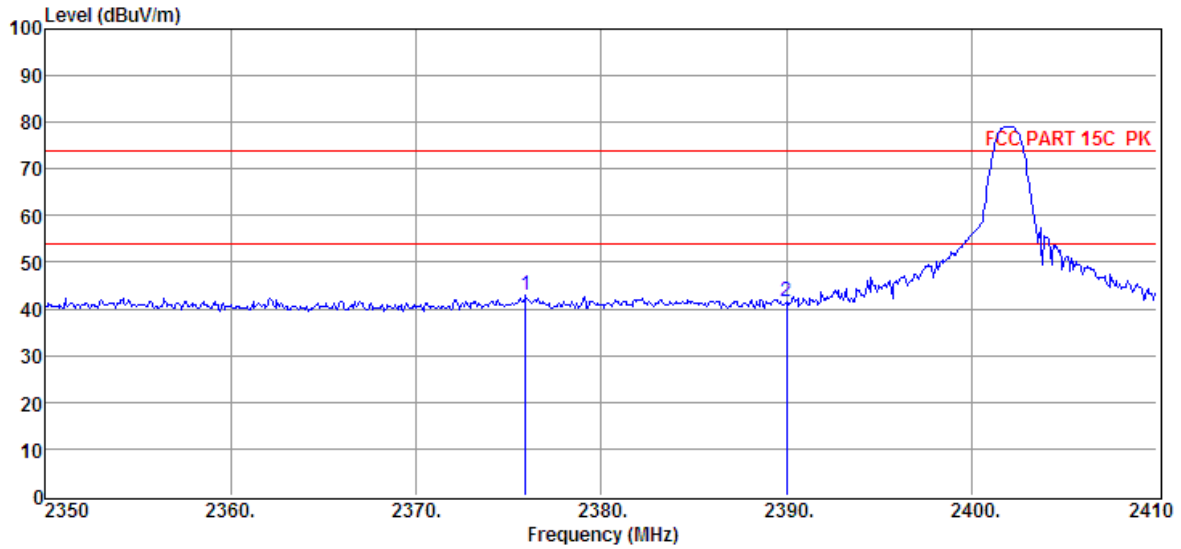

Item (Mark)	Freq. (MHz)	Read Level (dBμV)	Antenna Factor (dB/m)	PRM Facto r dB	Cable Loss dB	Result Level (dBμV/m)	Limit Line (dBμV/m)	Over Limit (dB)	Detector	Polarization
1	2375.92	36.62	29.72	29.39	6.01	42.96	74.00	-31.04	Peak	HORIZONTAL
2	2390.02	35.30	29.78	29.42	6.03	41.69	74.00	-32.31	Peak	HORIZONTAL

RESTRICTED BANDEDGE (LOW CHANNEL, VERTICAL)

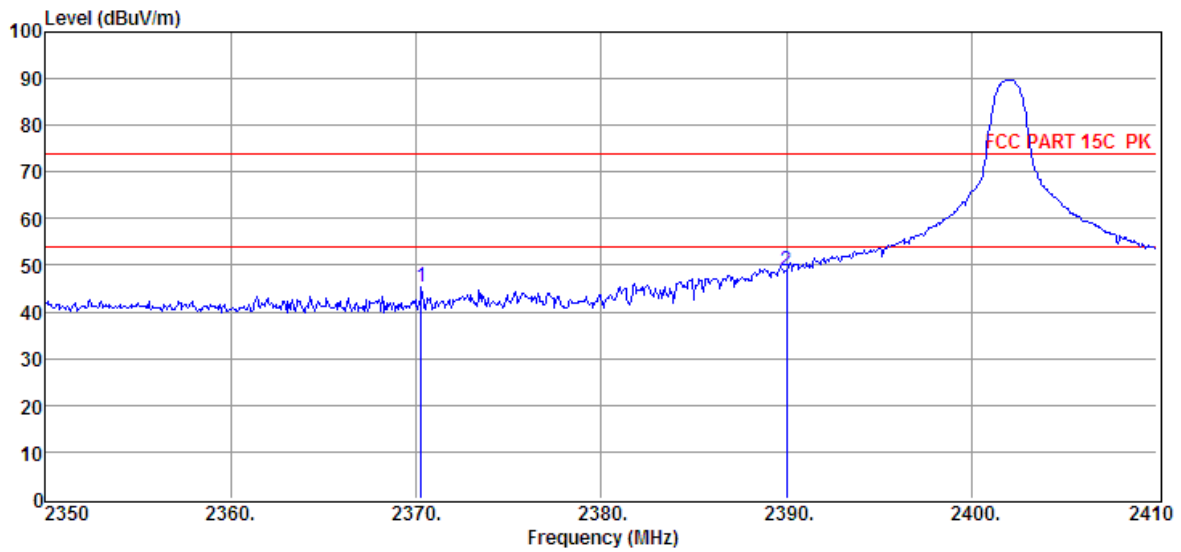

Item (Mark)	Freq. (MHz)	Read Level (dBμV)	Antenna Factor (dB/m)	PRM Facto r dB	Cable Loss dB	Result Level (dBμV/m)	Limit Line (dBμV/m)	Over Limit (dB)	Detector	Polarization
1	2370.28	38.87	29.70	29.37	6.01	45.21	74.00	-28.79	Peak	VERTICAL
2	2390.02	42.34	29.78	29.42	6.03	48.73	74.00	-25.27	Peak	VERTICAL

RESTRICTED BANDEDGE (HIGH CHANNEL, HORIZONTAL)

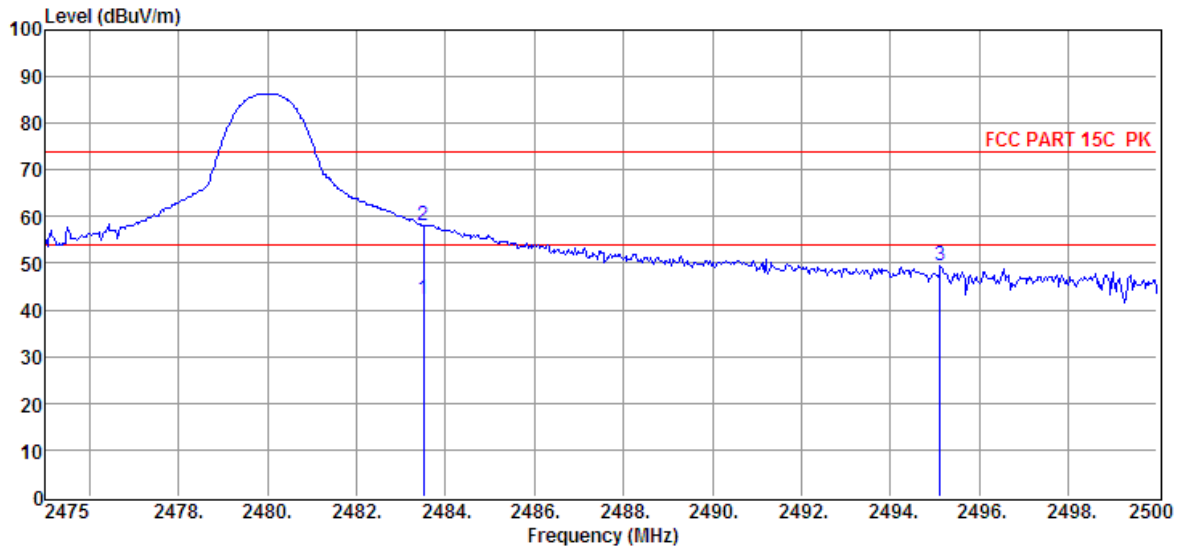

Item (Mark)	Freq. (MHz)	Read Level (dBμV)	Antenna Factor (dB/m)	PRM Facto r dB	Cable Loss dB	Result Level (dBμV/m)	Limit Line (dBμV/m)	Over Limit (dB)	Detecto r	Polarization
1	2483.50	35.63	30.14	29.71	6.13	42.19	54.00	-11.81	Average	HORIZONTAL
2	2483.50	51.51	30.14	29.71	6.13	58.07	74.00	-15.93	Peak	HORIZONTAL
3	2495.13	42.75	30.18	29.73	6.17	49.37	74.00	-24.63	Peak	HORIZONTAL

RESTRICTED BANDEDGE (HIGH CHANNEL, VERTICAL)

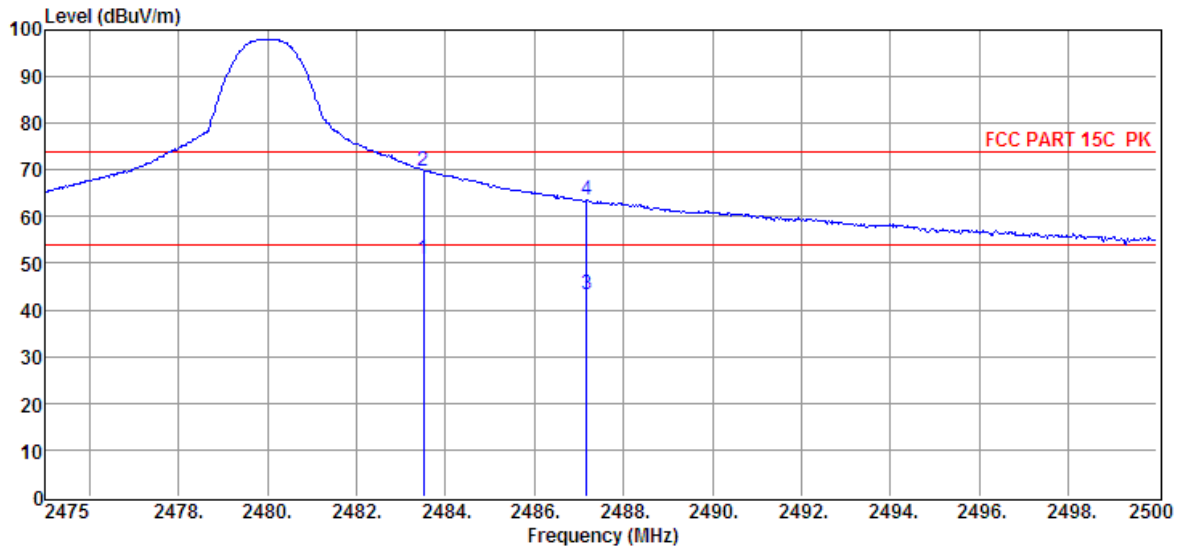

Item (Mark)	Freq. (MHz)	Read Level (dB μ V)	Antenna Factor (dB/m)	PRM Facto r dB	Cable Loss dB	Result Level (dB μ V/m)	Limit Line (dB μ V/m)	Over Limit (dB)	Detector	Polarization
1	2483.50	44.35	30.14	29.71	6.13	50.91	54.00	-3.09	Average	VERTICAL
2	2483.50	63.29	30.14	29.71	6.13	69.85	74.00	-4.15	Peak	VERTICAL
3	2487.18	36.63	30.15	29.71	6.13	43.20	54.00	-10.80	Average	VERTICAL
4	2487.18	56.89	30.15	29.71	6.13	63.46	74.00	-10.54	Peak	VERTICAL

Note: EUT in each of three orthogonal axis emissions had been tested, but only the worst case (X axis) data recorded in the report.

7.3. SPURIOUS EMISSIONS (1~25GHz)

HARMONICS AND SPURIOUS EMISSIONS

Freq (MHz)	Read level (dBμV)	Antenna Factor (dB/m)	PRM Factor (dB)	Cable Loss (dB)	Result Level (dBμV/m)	Limit (dBμV/m)	Margin (dB)	Detector type	Polarization
GFSK Tx mode 2402MHz									
4791.00	35.62	33.74	29.31	8.46	48.51	74.00	-25.49	Peak	VERTICAL
6474.00	34.26	35.76	29.78	9.93	50.17	74.00	-23.83	Peak	VERTICAL
7375.00	34.87	36.50	30.65	10.75	51.47	74.00	-22.53	Peak	VERTICAL
7885.00	34.76	36.68	31.09	11.08	51.43	74.00	-22.57	Peak	VERTICAL
8990.00	33.69	37.46	32.32	11.81	50.64	74.00	-23.36	Peak	VERTICAL
13529.00	34.09	39.33	35.17	14.81	53.06	74.00	-20.94	Peak	VERTICAL
4791.00	36.20	33.74	29.31	8.46	49.09	74.00	-24.91	Peak	HORIZONTAL
6406.00	34.57	35.65	29.66	9.88	50.44	74.00	-23.56	Peak	HORIZONTAL
7120.00	34.72	36.30	30.44	10.55	51.13	74.00	-22.87	Peak	HORIZONTAL
8004.00	34.96	36.69	31.13	11.13	51.65	74.00	-22.35	Peak	HORIZONTAL
8990.00	34.50	37.46	32.32	11.81	51.45	74.00	-22.55	Peak	HORIZONTAL
13274.00	35.01	39.08	35.50	14.74	53.33	74.00	-20.67	Peak	HORIZONTAL
GFSK Tx mode 2441MHz									
4060.00	35.20	33.45	29.05	7.67	47.27	74.00	-26.73	Peak	VERTICAL
4961.00	39.93	33.71	29.35	8.63	52.92	74.00	-21.08	Peak	VERTICAL
8004.00	35.65	36.69	31.13	11.13	52.34	74.00	-21.66	Peak	VERTICAL
8990.00	33.86	37.46	32.32	11.81	50.81	74.00	-23.19	Peak	VERTICAL
11234.00	34.48	37.28	34.25	13.53	51.04	74.00	-22.96	Peak	VERTICAL
12050.00	35.07	37.67	34.82	14.26	52.18	74.00	-21.82	Peak	VERTICAL
4910.00	36.84	33.72	29.33	8.58	49.81	74.00	-24.19	Peak	HORIZONTAL
6916.00	34.91	36.13	30.33	10.37	51.08	74.00	-22.92	Peak	HORIZONTAL
7936.00	35.21	36.69	31.11	11.10	51.89	74.00	-22.11	Peak	HORIZONTAL
9024.00	34.38	37.45	32.33	11.83	51.33	74.00	-22.67	Peak	HORIZONTAL
11064.00	33.03	37.66	34.08	13.49	50.10	74.00	-23.90	Peak	HORIZONTAL
13206.00	34.77	39.01	35.54	14.73	52.97	74.00	-21.03	Peak	HORIZONTAL
GFSK Tx mode 2480MHz									
3244.00	36.29	31.80	30.01	7.03	45.11	74.00	-28.89	Peak	VERTICAL
4961.00	40.44	33.71	29.35	8.63	53.43	74.00	-20.57	Peak	VERTICAL
6100.00	34.24	35.17	29.27	9.74	49.88	74.00	-24.12	Peak	VERTICAL
8004.00	35.25	36.69	31.13	11.13	51.94	74.00	-22.06	Peak	VERTICAL
9075.00	34.23	37.33	32.35	11.89	51.10	74.00	-22.90	Peak	VERTICAL
11030.00	34.01	37.73	34.03	13.49	51.20	74.00	-22.80	Peak	VERTICAL
5029.00	34.33	33.76	29.35	8.71	47.45	74.00	-26.55	Peak	HORIZONTAL
6899.00	34.99	36.12	30.31	10.33	51.13	74.00	-22.87	Peak	HORIZONTAL
7851.00	34.25	36.67	31.07	11.05	50.90	74.00	-23.10	Peak	HORIZONTAL
9109.00	34.06	37.26	32.36	11.95	50.91	74.00	-23.09	Peak	HORIZONTAL
11149.00	32.95	37.47	34.17	13.51	49.76	74.00	-24.24	Peak	HORIZONTAL
12135.00	33.29	37.79	34.87	14.35	50.56	74.00	-23.44	Peak	HORIZONTAL
Result: Pass									
Note1: 1.30MHz~18GHz: (Scan with GFSK, π/4 QPSK, 8-DPSK, the worst case is GFSK Mode) 2. Result Level = Read Level + Antenna Factor + Cable loss - PRM Factor. Note2: EUT in each of three orthogonal axis emissions had been tested, but only the worst case (X axis) data recorded in the report.									

7.4. SPURIOUS EMISSIONS 30M ~ 1 GHz

7.4.1. GFSK MODE

SPURIOUS EMISSIONS 30 TO 1000 MHz (WORST-CASE CONFIGURATION)

Temperature:	24.5°C	Relative Humidity:	55%
Pressure:	1012 hPa	Test Voltage:	AC 120V/60Hz
Test Mode:	Tx Mode	Polarization:	HORIZONTAL

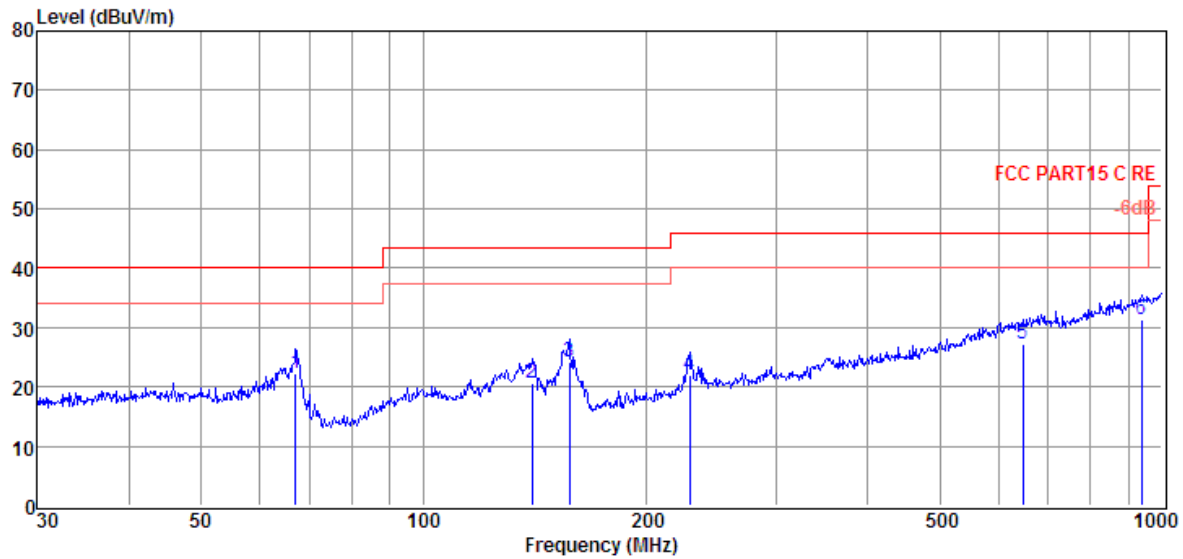

Item (Mark)	Freq. (MHz)	Read Level (dBμV)	Antenna Factor (dB/m)	Cable Loss (dB)	Result Level (dBμV/m)	Limit Line (dBuV/m)	Over Limit (dB)	Detector	Polarization
1	67.20	9.68	8.60	4.04	22.32	40.00	-17.68	QP	HORIZONTAL
2	140.34	8.80	7.40	4.54	20.74	43.50	-22.76	QP	HORIZONTAL
3	157.56	11.50	7.95	4.65	24.10	43.50	-19.40	QP	HORIZONTAL
4	229.29	5.26	11.59	5.04	21.89	46.00	-24.11	QP	HORIZONTAL
5	647.39	1.22	19.45	6.66	27.33	46.00	-18.67	QP	HORIZONTAL
6	938.83	0.85	22.97	7.52	31.34	46.00	-14.66	QP	HORIZONTAL

Temperature:	24.5°C	Relative Humidity:	55%
Pressure:	1012 hPa	Test Voltage:	AC 120V/60Hz
Test Mode:	Tx Mode	Polarization:	VERTICAL

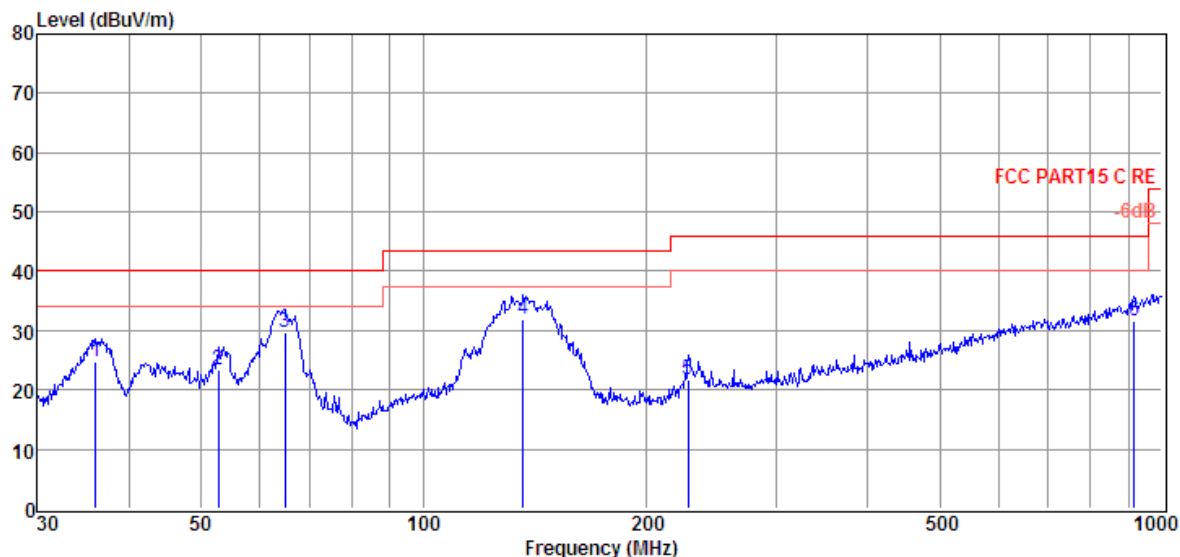

Item (Mark)	Freq. (MHz)	Read Level (dBμV)	Antenna Factor (dB/m)	Cable Loss (dB)	Result Level (dBμV/m)	Limit Line (dBμV/m)	Over Limit (dB)	Detector	Polarization
1	36.00	8.89	12.00	3.74	24.63	40.00	-15.37	QP	VERTICAL
2	52.76	7.73	11.70	3.92	23.35	40.00	-16.65	QP	VERTICAL
3	64.89	16.05	9.55	4.02	29.62	40.00	-10.38	QP	VERTICAL
4	136.46	19.78	7.61	4.52	31.91	43.50	-11.59	QP	VERTICAL
5	228.49	5.23	11.57	5.03	21.83	46.00	-24.17	QP	VERTICAL
6	916.07	1.58	22.62	7.46	31.66	46.00	-14.34	QP	VERTICAL

Note: EUT in each of three orthogonal axis emissions had been tested, but only the worst case (X axis) data recorded in the report.

7.5. SPURIOUS EMISSIONS BELOW 30M

Note 1: The low frequency, which started from 9 kHz to 30MHz, was pre-scanned and the result which was 20dB lower than the limit line per 15.31(o) was not reported.

Note 2: EUT in each of three orthogonal axis emissions had been tested, but only the worst case (X axis) data recorded in the report.

8. AC POWER LINE CONDUCTED EMISSIONS

LIMITS

Please refer to FCC §15.207 (a) and RSS-Gen Clause 8.8

FREQUENCY (MHz)	Class A (dBuV)		Class B (dBuV)	
	Quasi-peak	Average	Quasi-peak	Average
0.15 -0.5	79.00	66.00	66 - 56 *	56 - 46 *
0.50 -5.0	73.00	60.00	56.00	46.00
5.0 -30.0	73.00	60.00	60.00	50.00

TEST SETUP AND PROCEDURE

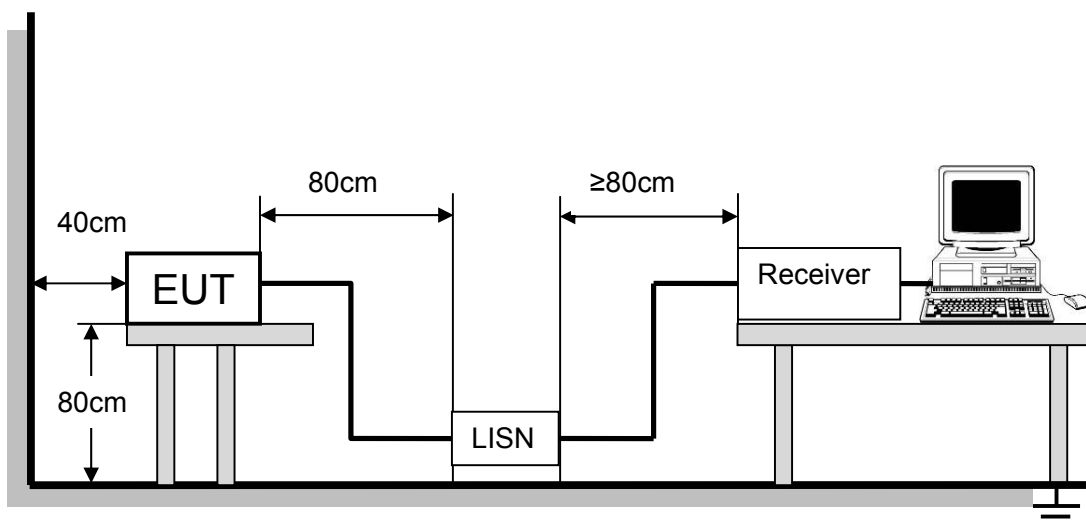

The EUT is put on a table of non-conducting material that is 80cm high. The vertical conducting wall of shielding is located 40cm to the rear of the EUT. The power line of the EUT is connected to the AC mains through a Artificial Mains Network (A.M.N.). A EMI Measurement Receiver (R&S Test Receiver ESR3) is used to test the emissions from both sides of AC line. According to the requirements in Section 7 and 13 of ANSI C63.4-2014. Conducted emissions from the EUT measured in the frequency range between 0.15 MHz and 30MHz using CISPR Quasi-Peak and average detector mode. The bandwidth of EMI test receiver is set at 9kHz.

The arrangement of the equipment is installed to meet the standards and operating in a manner, which tends to maximize its emission characteristics in a normal application.

TEST RESULTS

Temperature:	24.5°C	Relative Humidity:	55%
Pressure:	1012 hPa	Test Voltage:	AC 120V/60Hz
Test Mode:	Tx Mode	Phase :	L1

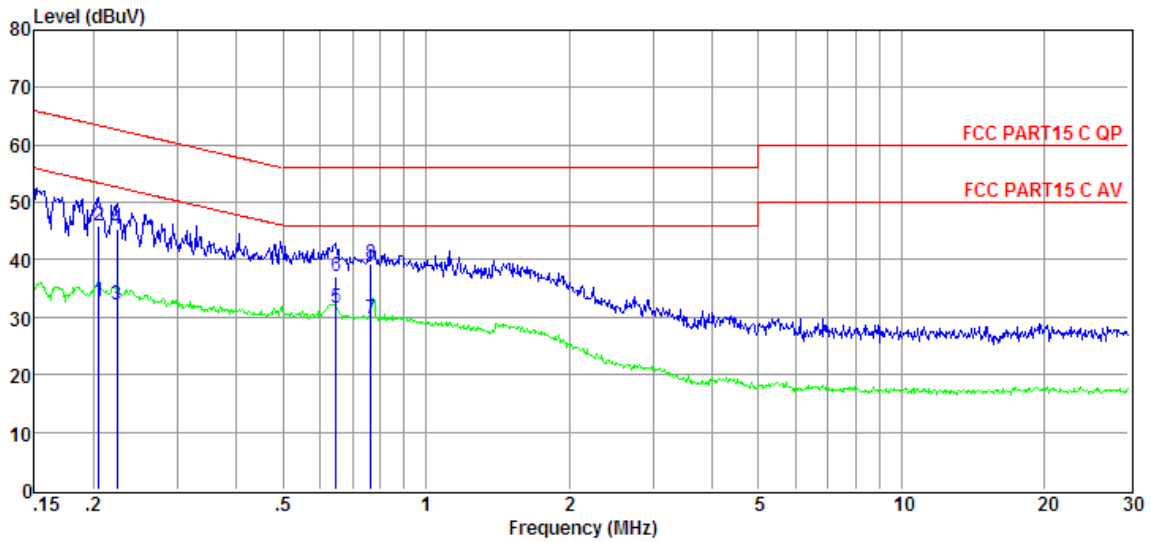

Item (Mark)	Freq. (MHz)	Read Level (dBμV)	LISN Factor (dB)	Cable Loss (dB)	Pulse Limiter Factor (dB)	Result Level (dBμV)	Limit Line (dBμV)	Over Limit (dB)	Detector	Phase
1	0.21	13.18	9.61	0.02	9.86	32.67	53.40	-20.73	Average	LINE
2	0.21	26.52	9.61	0.02	9.86	46.01	63.40	-17.39	QP	LINE
3	0.22	12.78	9.61	0.02	9.86	32.27	52.66	-20.39	Average	LINE
4	0.22	26.00	9.61	0.02	9.86	45.49	62.66	-17.17	QP	LINE
5	0.65	12.21	9.61	0.03	9.86	31.71	46.00	-14.29	Average	LINE
6	0.65	17.69	9.61	0.03	9.86	37.19	56.00	-18.81	QP	LINE
7	0.77	10.07	9.61	0.03	9.86	29.57	46.00	-16.43	Average	LINE
8	0.77	19.83	9.61	0.03	9.86	39.33	56.00	-16.67	QP	LINE

- Note: 1. Result Level = Read Level + LISN Factor + Pulse Limiter Factor + Cable loss.
 2. If QP Result complies with AV limit, AV Result is deemed to comply with AV limit.
 3. Test setup: RBW: 200 Hz (9 kHz—150 kHz), 9 kHz (150 kHz—30 MHz).
 4. Step size: 80Hz (0.009MHz-0.15MHz), 4 kHz (0.15MHz-30MHz), Scan time: auto.

Temperature:	24.5°C	Relative Humidity:	55%
Pressure:	1012 hPa	Test Voltage:	AC 120V/60Hz
Test Mode:	Tx Mode	Phase :	N

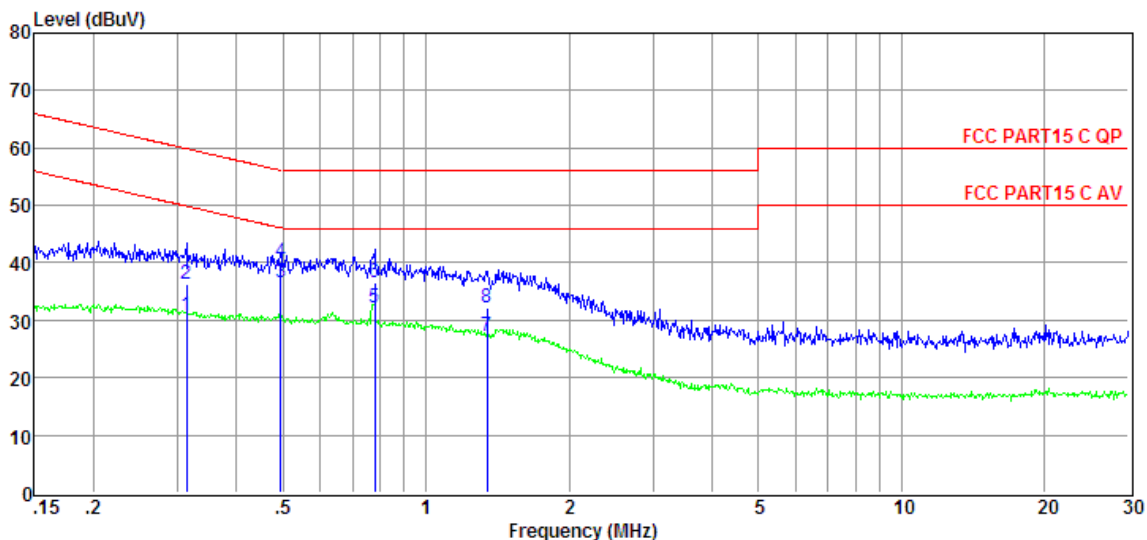

Item (Mark)	Freq. (MHz)	Read Level (dBμV)	LISN Factor (dB)	Cable Loss (dB)	Pulse Limiter Factor (dB)	Result Level (dBμV)	Limit Line (dBμV)	Over Limit (dB)	Detector	Phase
1	0.31	11.33	9.61	0.02	9.86	30.82	49.88	-19.06	Average	NEUTRAL
2	0.31	16.79	9.61	0.02	9.86	36.28	59.88	-23.60	QP	NEUTRAL
3	0.49	17.19	9.61	0.02	9.86	36.68	46.10	-9.42	Average	NEUTRAL
4	0.49	20.54	9.61	0.02	9.86	40.03	56.10	-16.07	QP	NEUTRAL
5	0.78	12.68	9.61	0.03	9.86	32.18	46.00	-13.82	Average	NEUTRAL
6	0.78	17.16	9.61	0.03	9.86	36.66	56.00	-19.34	QP	NEUTRAL
7	1.35	7.83	9.61	0.03	9.86	27.33	46.00	-18.67	Average	NEUTRAL
8	1.35	12.62	9.61	0.03	9.86	32.12	56.00	-23.88	QP	NEUTRAL

Note: 1. Result Level = Read Level + LISN Factor + Pulse Limiter Factor + Cable loss.
 2. If QP Result complies with AV limit, AV Result is deemed to comply with AV limit.
 3. Test setup: RBW: 200 Hz (9 kHz—150 kHz), 9 kHz (150 kHz—30 MHz).
 4. Step size: 80Hz (0.009MHz-0.15MHz), 4 kHz (0.15MHz-30MHz), Scan time: auto.

9. ANTENNA REQUIREMENTS

APPLICABLE REQUIREMENTS

Please refer to FCC §15.203

If directional gain of transmitting antennas is greater than 6dBi, the power shall be reduced by the same level in dB comparing to gain minus 6dBi. For the fixed point-to-point operation, the power shall be reduced by one dB for every 3 dB that the directional gain of the antenna exceeds 6 dBi. The use of a permanently attached antenna or of an antenna that uses a unique coupling to the intentional radiator shall be considered sufficient to comply with the FCC rule.

ANTENNA CONNECTOR

EUT has a PCB antenna without antenna connector.

ANTENNA GAIN

The antenna gain of EUT is less than 6 dBi.

END OF REPORT