



Valued Quality. Delivered.

TEST REPORT

Report No.: 15070331HKG-002

Bellman & Symfon Europe AB

Application
For
Certification
(Original Grant
(FCC ID: WMSBETXBC)
(IC: 6693A-BETX3)

Transmitter

Prepared and Checked by:

Approved by:

Signed On File
Josie Yao
Engineer

Wong Kwok Yeung, Kenneth
Lead Engineer
Date: September 22, 2015

- Intertek's standard Terms and Conditions can be obtained at our website <http://www.intertek.com/terms/>.
- The test report only allows to be revised within the retention period unless further standard or the requirement was noticed.
- This report is for the exclusive use of Intertek's Client and is provided pursuant to the agreement between Intertek and its Client. Intertek's responsibility and liability are limited to the terms and conditions of the agreement. Intertek assumes no liability to any party, other than to the Client in accordance with the agreement, for any loss, expense or damage occasioned by the use of this report. Only the Client is authorized to permit copying or distribution of this report and then only in its entirety. Any use of the Intertek name or one of its marks for the sale or advertisement of the tested material, product or service must first be approved in writing by Intertek. The observations and test results in this report are relevant only to the sample tested. This report by itself does not imply that the material, product, or service is or has ever been under an Intertek certification program.

Intertek Testing Services Hong Kong Ltd.

2/F., Garment Centre, 576 Castle Peak Road, Kowloon, Hong Kong.

Tel: (852) 2173 8888 Fax: (852) 2785 5487 Website: www.hk.intertek-ettsemko.com

INTERTEK TESTING SERVICES

GENERAL INFORMATION

Grantee:	Bellman & Symfon Europe AB
Grantee Address:	Södra Långebergsgatan 30 Västra Frölunda 421 32 Sweden
Contact Person:	Peter Jungvid
Tel:	+46 31 682820
Fax:	+46 31 682890
e-mail:	pj@bellman.com
Manufacturer:	Bellman & Symfon Europe AB
Manufacturer Address:	Södra Långebergsgatan 30 Västra Frölunda 421 32 Sweden
Brand Name:	Bellman & Symfon
Model:	BE1491
Type of EUT:	Transmitter
Description of EUT:	Baby Monitor TX / Room Monitor TX
Serial Number:	N/A
FCC ID / IC:	WMSBETXBC / 6693A-BETX3
Date of Sample Submitted:	July 07, 2015
Date of Test:	July 07, 2015 to September 15, 2015
Report No.:	15070331HKG-002
Report Date:	September 22, 2015
Environmental Conditions:	Temperature: +10 to 40°C Humidity: 10 to 90%

INTERTEK TESTING SERVICES

SUMMARY OF TEST RESULT

TEST SPECIFICATION	REFERENCE	RESULTS
Transmitter Field Strength, Bandwidth and Timing Requirement	15.231(a) / RSS-210 A1.1.1	Pass

The equipment under test is found to be complying with the following standards:
FCC Part 15, October 1, 2014 Edition
RSS-210 Issue 8, December 2010
RSS-Gen Issue 4, December 2014

- Note: 1. The EUT uses a permanently attached antenna which, in accordance to section 15.203, is considered sufficient to comply with the provisions of this section.
2. Pursuant to FCC part 15 Section 15.215(c), the 20 dB bandwidth of the emission was contained within the frequency band designated (mentioned as above) which the EUT operated. The effects, if any, from frequency sweeping, frequency hopping, other modulation techniques and frequency stability over excepted variations in temperature and supply voltage were considered.

INTERTEK TESTING SERVICES

Table of Contents

1.0	<u>General Description</u>	1
1.1	Product Description	1
1.2	Related Submittal(s) Grants.....	1
1.3	Test Methodology	1
1.4	Test Facility	1
2.0	<u>System Test Configuration</u>	2
2.1	Justification.....	2
2.2	EUT Exercising Software.....	2
2.3	Special Accessories	2
2.4	Measurement Uncertainty.....	2
2.5	Support Equipment List and Description.....	2
3.0	<u>Emission Results</u>	3
3.1	Field Strength Calculation.....	3
3.2	Radiated Emission Configuration Photograph	4
3.3	Radiated Emission Data	4
4.0	<u>Equipment Photographs</u>	7
5.0	<u>Product Labelling</u>	7
6.0	<u>Technical Specifications</u>	7
7.0	<u>Instruction Manual</u>	7
8.0	<u>Miscellaneous Information</u>	8
8.1	Measured Bandwidth.....	10
8.2	Discussion of Pulse Desensitization	11
8.3	Calculation of Average Factor.....	11
8.4	Emissions Test Procedures.....	14
8.5	Occupied Bandwidth.....	17
9.0	<u>Confidentiality Request</u>	18
10.0	<u>Equipment List</u>	18

INTERTEK TESTING SERVICES

1.0 General Description

1.1 Product Description

The equipment under test (EUT) is a transmitter of sound extender for Remote Baby/Room Monitor operating at 433.92MHz which is operated by a crystal. The EUT is powered by DC3.0V (2 x 1.5V AA batteries). There are a test button and a microphone inside the EUT. A contact mat can also be connected to the EUT to notify if the child gets out of the bed. The transmitter will be activated and then transmit a signal to corresponding receiver once either the microphone can be received the sound which touch the limit (by user specified) or the test button is pressed by the user. For microphone portion, the transmitter will cease transmission within 5 seconds after activation. For test button, the manually operated transmitter will automatically deactivate the transmitter within not more than 5 seconds of being released.

Antenna Type: Internal, Integral

For electronic filing, the brief circuit description is saved with filename: descri.pdf.

1.2 Related Submittal(s) Grants

This is a single application for certification of a transmitter.

The receiver for this transmitter has been authorized by Declaration of the Conformity procedure.

1.3 Test Methodology

Radiated emission measurements were performed according to the procedures in ANSI C63.10 (2013). All radiated measurements were performed in an 3m Chamber. Preliminary scans were performed in the 3m Chamber only to determine worst case modes. All radiated tests were performed at an antenna to EUT distance of 3 meters, unless stated otherwise in the “**Justification Section**” of this Application.

1.4 Test Facility

The 3m Chamber used to collect the radiated data is located at Workshop No. 3, G/F., World-Wide Industrial Centre, 43-47 Shan Mei Street, Fo Tan, Sha Tin, N.T., Hong Kong. This test facility and site measurement data have been placed on file with the FCC and IC.

INTERTEK TESTING SERVICES

2.0 **System Test Configuration**

2.1 Justification

The system was configured for testing in a typical fashion (as a customer would normally use it), and in the confines as outlined in ANSI C63.10 (2013).

The device was powered by 3VDC (2 x 1.5AA batteries).

For maximizing emissions, the EUT was rotated through 360°, the antenna height was varied from 1 meter to 4 meters above the ground plane, and the antenna polarization was changed. This step by step procedure for maximizing emissions led to the data reported in Exhibit 3.0.

The rear of unit shall be flushed with the rear of the table.

The equipment under test (EUT) was configured for testing in a typical fashion (as a customer would normally use it). The EUT was mounted to a plastic stand if necessary and placed on the wooden turntable, which enabled the engineer to maximize emissions through its placement in the three orthogonal axes.

All the operation modes have been considered and the worst case shown in the report.

2.2 EUT Exercising Software

There was no special software to exercise the device. Once the unit is powered up, it transmits the RF signal continuously.

2.3 Special Accessories

There are no special accessories necessary for compliance of this product.

2.4 Measurement Uncertainty

When determining of the test conclusion, the Measurement Uncertainty of test has been considered.

Uncertainty and Compliance - Unless the standard specifically states that measured values are to be extended by the measurement uncertainty in determining compliance, all compliance determinations are based on the actual measured value.

2.5 Support Equipment List and Description

1. Contact Mat (Connect to Ext trig input) (Provided by Applicant)

INTERTEK TESTING SERVICES

3.0 Emission Results

Data is included of the worst case configuration (the configuration which resulted in the highest emission levels). A sample calculation, configuration photographs and data tables of the emissions are included.

3.1 Field Strength Calculation

The field strength is calculated by adding the Antenna Factor and Cable Factor, and subtracting the Amplifier Gain (if any), Average Factor (optional) from the measured reading. The basic equation with a sample calculation is as follows:

$$FS = RA + AF + CF - AG - AV$$

where

- FS = Field Strength in dB μ V/m
- RA = Receiver Amplitude (including preamplifier) in dB μ V
- CF = Cable Attenuation Factor in dB
- AF = Antenna Factor in dB
- AG = Amplifier Gain in dB
- AV = Average Factor in dB

In the following table(s), the reading shown on the data table reflects the preamplifier gain. An example for the calculations in the following table is as follows:

$$FS = RR + LF$$

where

- FS = Field Strength in dB μ V/m
- RR = RA - AG - AV in dB μ V
- LF = CF + AF in dB

Assume a receiver reading of 52.0 dB μ V is obtained. The antenna factor of 7.4 dB and cable factor of 1.6 dB are added. The amplifier gain of 29 dB and average factor of 5 dB are subtracted, giving a field strength of 27 dB μ V/m. This value in dB μ V/m was converted to its corresponding level in μ V/m.

$$\begin{aligned} RA &= 52.0 \text{ dB}\mu\text{V/m} \\ AF &= 7.4 \text{ dB} & RR &= 18.0 \text{ dB}\mu\text{V} \\ CF &= 1.6 \text{ dB} & LF &= 9.0 \text{ dB} \\ AG &= 29.0 \text{ dB} \\ AV &= 5.0 \text{ dB} \\ FS &= RR + LF \\ FS &= 18 + 9 = 27 \text{ dB}\mu\text{V/m} \end{aligned}$$

$$\text{Level in } \mu\text{V/m} = \text{Common Antilogarithm } [(27 \text{ dB}\mu\text{V/m})/20] = 22.4 \mu\text{V/m}$$

INTERTEK TESTING SERVICES

3.2 Radiated Emission Configuration Photograph

The worst case in radiated emission was found at 433.926 MHz

For electronic filing, the worst case radiated emission configuration photographs are saved with filename: radiated photos.pdf.

3.3 Radiated Emission Data

The data on the following page lists the significant emission frequencies, the limit and the margin of compliance. Numbers with a minus sign are below the limit.

Judgment: Passed by 2.3 dB

INTERTEK TESTING SERVICES

Applicant: Bellman & Symfon Europe AB
 Model: BE1491

Date of Test: September 15, 2015

Worst-Case Operating Mode: Transmitting (Manual mode - test Button)

Table 1
Radiated Emissions
 Pursuant to FCC Part 15 Section 15.231(a) / RSS-210 A1.1.1 Requirement

Polarization	Frequency (MHz)	Reading (dB μ V)	Pre-Amp (dB)	Antenna factor (dB)	Average Factor (dB)	Net at 3m (dB μ V/m)	Average Limit at 3m (dB μ V/m)	Margin (dB)
H	433.926	83.2	16	25.0	13.7	78.5	80.8	-2.3
V	867.852	32.5	16	31.0	13.7	33.8	60.8	-27.0
V	1301.778	57.9	34	26.1	13.7	36.3	54.0	-17.7
V	1735.704	50.6	34	27.2	13.7	30.1	60.8	-30.7
V	2169.630	57.6	34	29.4	13.7	39.3	60.8	-21.5
V	2603.556	49.9	34	30.4	13.7	32.6	60.8	-28.2
V	3037.482	51.8	34	31.9	13.7	36.0	60.8	-24.8
V	3471.408	52.5	34	31.9	13.7	36.7	60.8	-24.1
V	3905.334	51.5	34	33.3	13.7	37.1	54.0	-16.9
V	4339.260	50.7	34	34.8	13.7	37.8	54.0	-16.2

NOTES: 1. Peak Detector Data unless otherwise stated.

2. All measurements were made at 3 meters. Harmonic emissions not detected at the 3-meter distances were measured at 0.3-meter and an inverse proportional extrapolation was performed to compare the signal level to the 3-meter limit. No other harmonic emissions than those reported were detected at a test distance of 0.3-meter.
3. Negative sign in the column shows value below limit.
4. Horn antenna is used for the emission over 1000MHz.
5. Emission (the row indicated by **bold italic**) within the restricted band meets the requirement of FCC Part 15 Section 15.205 / RSS-210 Section 2.2.
6. Measurement Uncertainty is ± 5.3 dB at a level of confidence of 95%.

INTERTEK TESTING SERVICES

Applicant: Bellman & Symfon Europe AB
 Model: BE1491

Date of Test: September 15, 2015

Worst-Case Operating Mode: Transmitting (Manual mode - test button)

Table 2
Radiated Emissions
 Pursuant to FCC Part 15 Section 15.231(a) / RSS-210 A1.1.1 Requirement

Polarization	Frequency (MHz)	Reading (dBμV)	Pre-Amp (dB)	Antenna factor (dB)	Net at 3m (dBμV/m)	Peak Limit at 3m (dBμV/m)	Margin (dB)
H	433.926	83.2	16	25.0	92.2	100.8	-8.6
V	867.852	32.5	16	31.0	47.5	80.8	-33.3
V	1301.778	57.9	34	26.1	50.0	74.0	-24.0
V	1735.704	50.6	34	27.2	43.8	80.8	-37.0
V	2169.630	57.6	34	29.4	53.0	80.8	-27.8
V	2603.556	49.9	34	30.4	46.3	80.8	-34.5
V	3037.482	51.8	34	31.9	49.7	80.8	-31.1
V	3471.408	52.5	34	31.9	50.4	80.8	-30.4
V	3905.334	51.5	34	33.3	50.8	74.0	-23.2
V	4339.260	50.7	34	34.8	51.5	74.0	-22.5

- NOTES: 1. Peak Detector Data unless otherwise stated.
2. All measurements were made at 3 meters. Harmonic emissions not detected at the 3-meter distances were measured at 0.3-meter and an inverse proportional extrapolation was performed to compare the signal level to the 3-meter limit. No other harmonic emissions than those reported were detected at a test distance of 0.3-meter.
3. Negative sign in the column shows value below limit.
4. Horn antenna is used for the emission over 1000MHz.
5. Emission (the row indicated by **bold italic**) within the restricted band meets the requirement of FCC Part 15 Section 15.205 / RSS-210 Section 2.2.
6. Measurement Uncertainty is ±5.3dB at a level of confidence of 95%.

INTERTEK TESTING SERVICES

4.0 Equipment Photographs

For electronic filing, the photographs are saved with filename: external photos.pdf and internal photos.pdf.

5.0 Product Labelling

For electronics filing, the FCC/IC ID label artwork and the label location are saved with filename: label.pdf.

6.0 Technical Specifications

For electronic filing, the block diagram and schematic of the tested EUT are saved with filename: block.pdf and circuit.pdf respectively.

7.0 Instruction Manual

For electronic filing, a preliminary copy of the Instruction Manual is saved with filename: manual.pdf.

This manual will be provided to the end-user with each unit sold/leased in the United States and Canada.

INTERTEK TESTING SERVICES

8.0 Miscellaneous Information

The miscellaneous information includes details of the test procedure and measured bandwidth / calculation of factor such as pulse desensitization and averaging factor (calculation and timing diagram).

Timing Plot – the timing diagram about the manually operated transmitter (test button/ Contact Mat) and Internal Microphone Mode are shown as below;;

Pursuant to FCC Part 15 Section 15.231(a1) - A manually operated transmitter shall employ a switch that will automatically deactivate the transmitter within not more than 5 seconds of being released.

Manual Mode Transmission (Test button/ Contact Mat)
Result: Transmission Duration (Manual Mode)= 3.71s (Pass)

Pursuant to FCC Part 15 Section 15.231 (a2) – A transmitter activated automatically shall cease transmission within 5 seconds after activation.

Transmission automatically (Internal Microphone)
Result: Transmission Duration (Internal Microphone Triggered)= 2.20s (Pass)

INTERTEK TESTING SERVICES

Manual Mode:

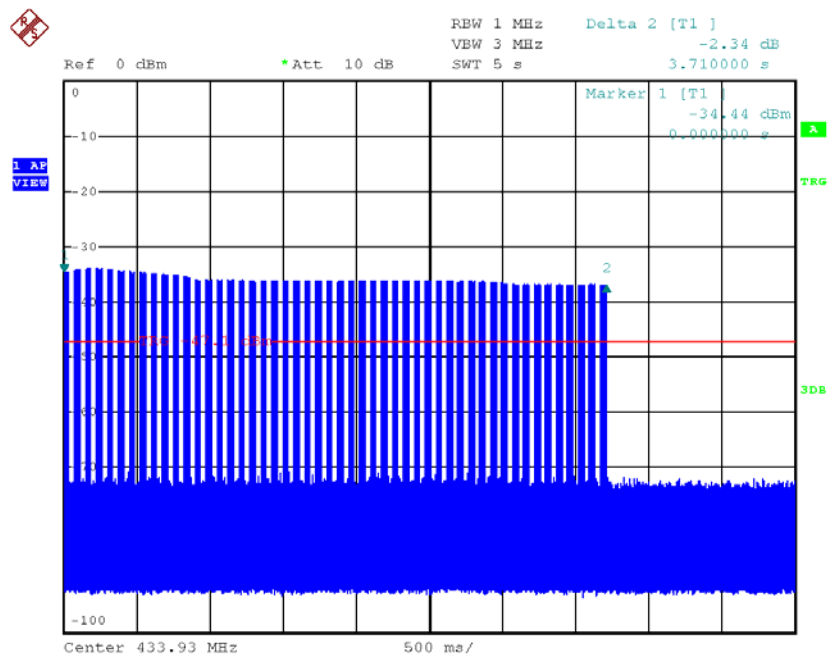

Internal Microphone Triggered:

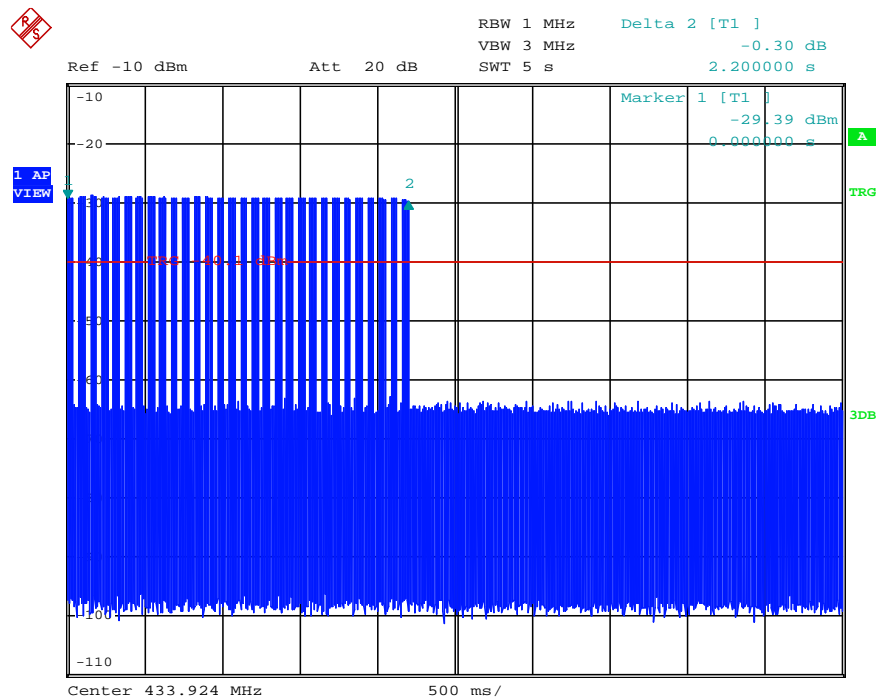

INTERTEK TESTING SERVICES

8.1 Measured Bandwidth

The plot shows the fundamental emission when modulated. From the plot, the bandwidth is observed to be 50kHz, at 20dBc where the bandwidth limit is 1.085MHz..

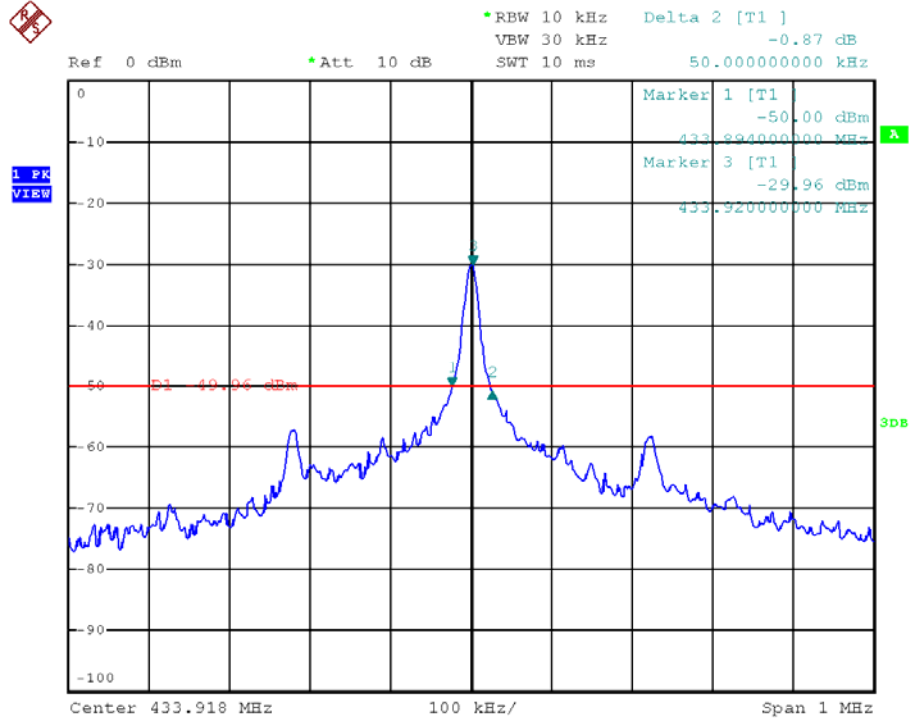

INTERTEK TESTING SERVICES

8.2 Discussion of Pulse Desensitization

Pulse desensitivity is not applicable for this device. The effective period (Teff) is approximately 0.96ms for a digital "1" bit which illustrated on technical specification, with a resolution bandwidth (3dB) of 1MHz, so the pulse desensitivity factor is 0dB.

8.3 Calculation of Average Factor

The duty cycle is simply the on-time divided by the period:

The duration of one cycle = 74.88ms

Effective period of the cycle = $0.96\text{ms} \times 10 + 1.92\text{ms} \times 3 = 15.36\text{ms}$

DC = $(15.36\text{ms}) / 74.88\text{ms} = 0.2051$

Therefore, the averaging factor is found by $20\log(0.2051) = -13.7\text{dB}$.

INTERTEK TESTING SERVICES

Average Factor (Manual mode – test button)

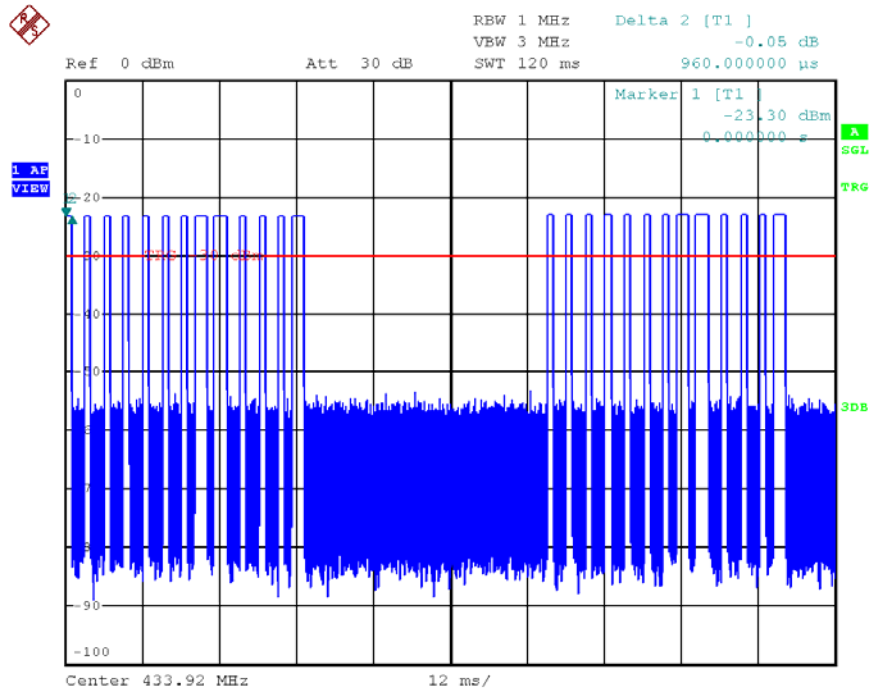
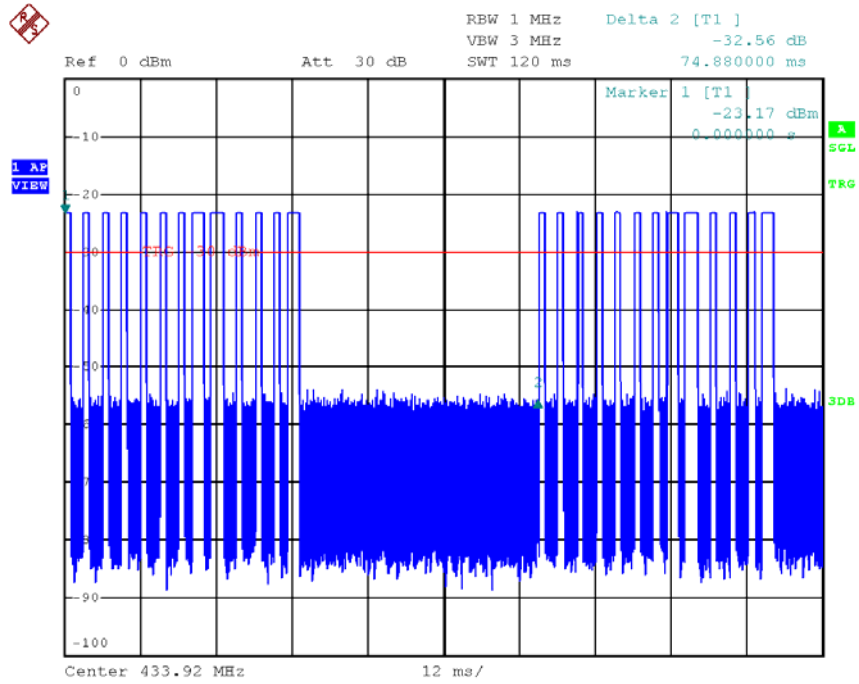

INTERTEK TESTING SERVICES

Average Factor

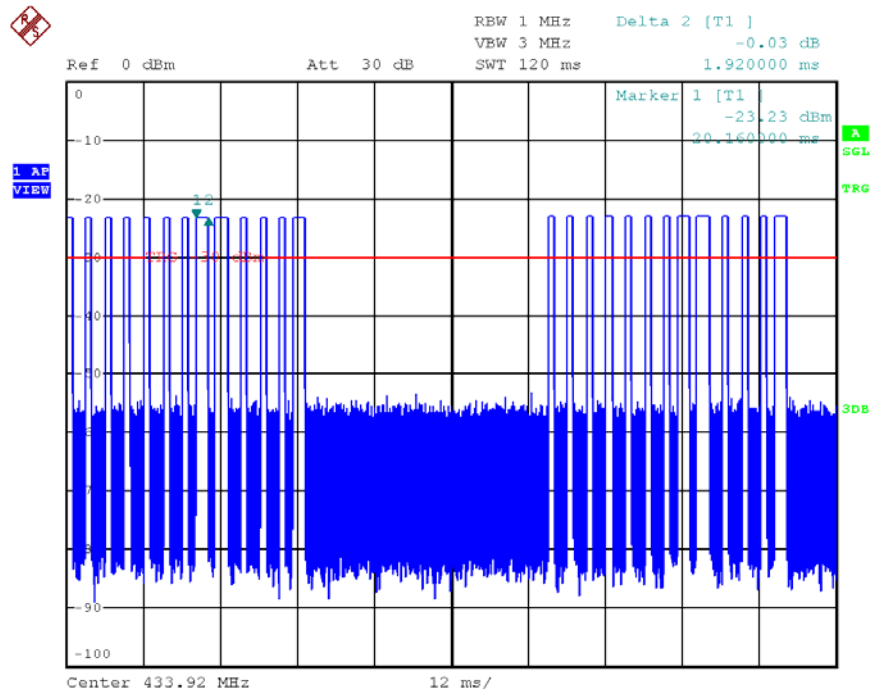

INTERTEK TESTING SERVICES

8.4 Emissions Test Procedures

The following is a description of the test procedure used by Intertek Testing Services Hong Kong Ltd. in the measurements of transmitter operating under the Part 15, Subpart C rules.

The transmitting equipment under test (EUT) is placed on a wooden turntable which is four feet in diameter and approximately 0.8m in height above the ground plane for emission measurement at or below 1GHz and 1.5m in height above the ground plane for emission measurement above 1GHz. During the radiated emissions test, the turntable is rotated and any cables leaving the EUT are manipulated to find the configuration resulting in maximum emissions. The EUT is adjusted through all three orthogonal axis to obtain maximum emission levels. The antenna height and polarization are also varied during the testing to search for maximum signal levels. The height of the antenna is varied from one to four meters.

Detector function for radiated emissions is in peak mode. Average readings, when required, are taken by measuring the duty cycle of the equipment under test and subtracting the corresponding amount in dB from the measured peak readings. A detailed description for the calculation of the average factor can be found in Exhibit 8.3.

The frequency range scanned is from the lowest radio frequency signal generated in the device which is greater than 9 kHz to the tenth harmonic of the highest fundamental frequency or 40 GHz, whichever is lower.

INTERTEK TESTING SERVICES

8.4 Emissions Test Procedures (cont'd)

The EUT is warmed up for 15 minutes prior to the test.

AC power to the unit is varied from 85% to 115% nominal and variation in the fundamental emission field strength is recorded. If battery powered, a new, fully charged battery is used.

Conducted measurements were made as described in ANSI C63.10 (2013).

The IF bandwidth used for measurement of radiated signal strength was 100 kHz or greater when frequency is below 1000 MHz. Where pulsed transmissions of short enough pulse duration warrant, a greater bandwidth is selected according to the recommendations of Hewlett Packard Application Note 150-2. A discussion of whether pulse desensitivity is applicable to this unit is included in this report (See Exhibit 8.1). Above 1000 MHz, a resolution bandwidth of 1 MHz is used.

Transmitter measurements are normally conducted at a measurement distance of three meters. However, to assure low enough noise floor in the forbidden bands and above 1 GHz, signals are acquired at a distance of one meter or less. All measurements are extrapolated to three meters using inverse scaling, unless otherwise reported. Measurements taken at a closer distance are so marked.

INTERTEK TESTING SERVICES

8.4.1 Radiated Emission Test Setup

The figure below shows the test setup, which is utilized to make these measurements.

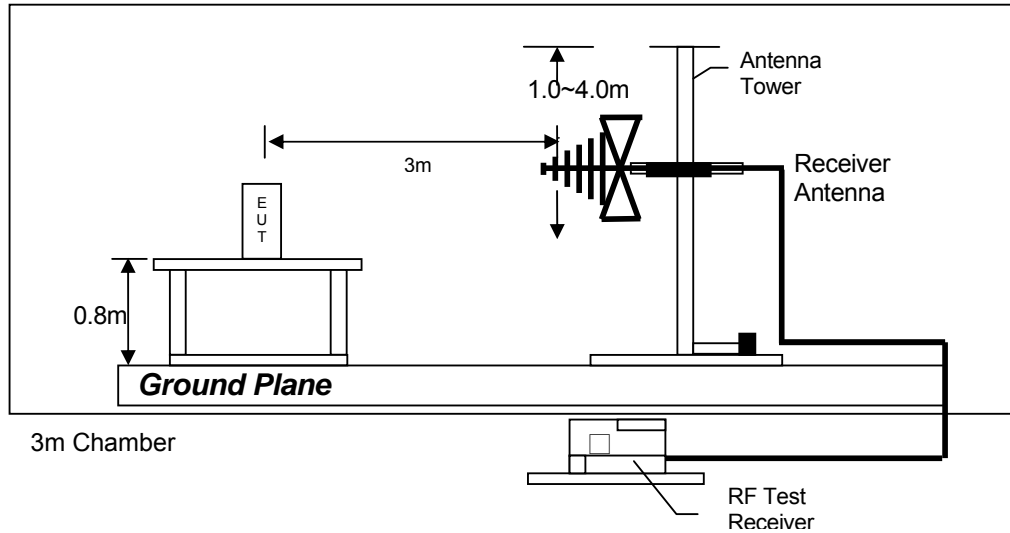

Test setup of radiated emissions up to 1GHz

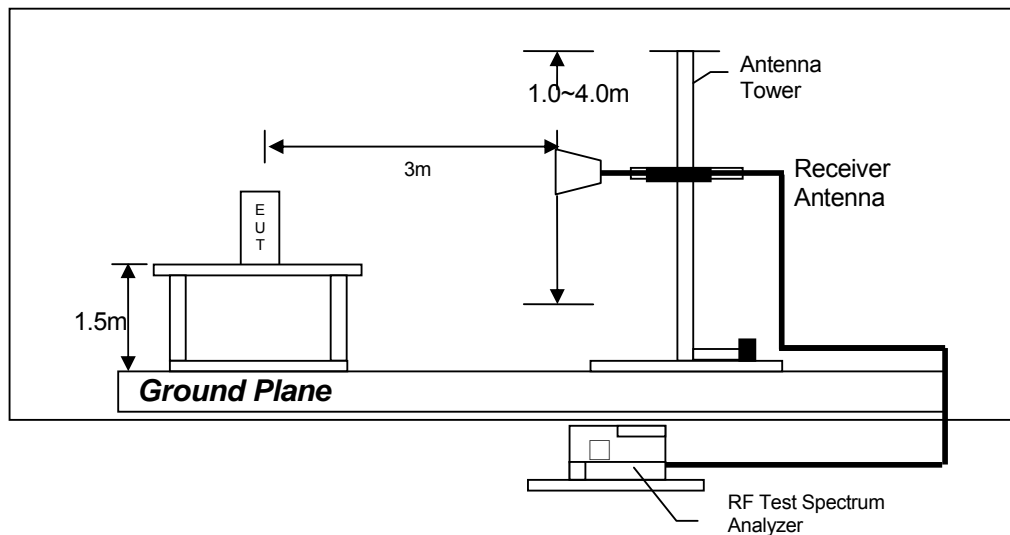

Test setup of radiated emissions above 1GHz

INTERTEK TESTING SERVICES

8.5 Occupied Bandwidth

Occupied Bandwidth Results:

Frequency (MHz)	Occupied Bandwidth (kHz)	Limit
433.920MHz	630	1.085MHz

The worst case is shown as below

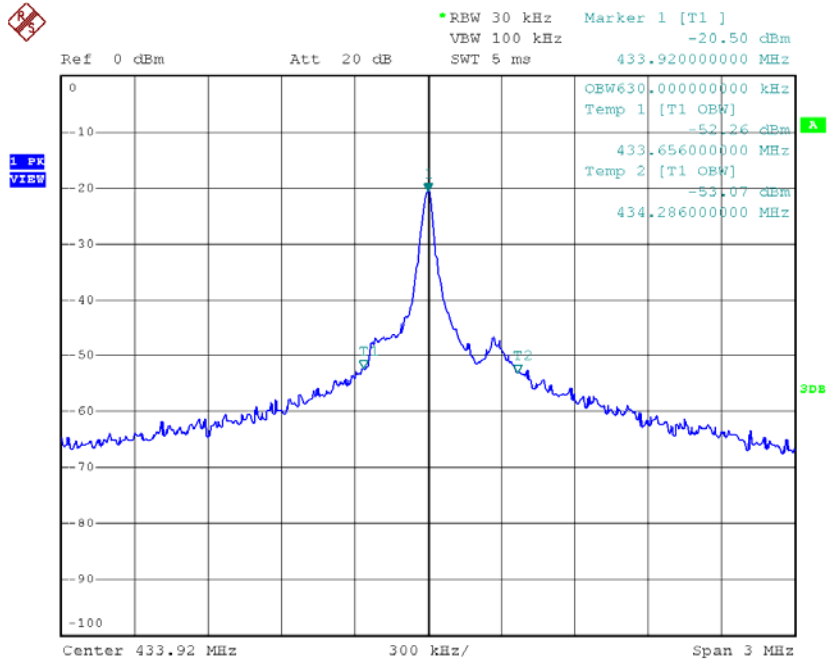

INTERTEK TESTING SERVICES

9.0 Confidentiality Request

For electronic filing, a preliminary copy of the confidentiality request is saved with filename: request.pdf.

10.0 Equipment List

1) Radiated Emissions Test

Equipment	EMI Test Receiver	Spectrum Analyzer
Registration No.	EW-3095	EW-2249
Manufacturer	R&S	R&S
Model No.	ESCI	FSP30
Calibration Date	Oct. 16, 2014	Nov. 19, 2014
Calibration Due Date	Oct. 16, 2015	Nov. 19, 2015

Equipment	BiConiLog Antenna	Pyramidal Horn Antenna	Double Ridged Guide Antenna
Registration No.	EW-3061	EW-0905	EW-1133
Manufacturer	EMCO	EMCO	EMCO
Model No.	3412E	3160-09	3115
Calibration Date	Jul. 22, 2015	Jun. 05, 2014	Apr. 30, 2014
Calibration Due Date	Jul. 22, 2016	Dec. 05, 2015	Oct. 30, 2015

2) Bandwidth & Average factor Measurement

Equipment	Spectrum Analyzer
Registration No.	EW-2329
Manufacturer	R&S
Model No.	FSP3
Calibration Date	Jun. 17, 2015
Calibration Due Date	Jun. 17, 2016

END OF TEST REPORT