

# televic

## UNITE SYSTEM

USER MANUAL



## Copyright Statement

No part of this publication or documentation accompanying this product may be reproduced in any form or by any means or used to make any derivative such as translation, transformation, or adaptation without the prior written permission of the publisher, except in case of brief quotations embodied in critical articles or reviews. Contents are subject to change without prior notice.

Copyright © 2024 by Televic Conference NV. All rights reserved.

The authors of this manual have made every effort in the preparation of this book to ensure the accuracy of the information. However, the information in this manual is supplied without warranty, either express or implied. Neither the authors, Televic Conference NV, nor its dealers or distributors will be held liable for any damages caused or alleged to be caused either directly or indirectly by this book.

## Trademarks

All terms mentioned in this manual that are known to be trademarks or service marks have been appropriately capitalized. Televic NV cannot attest to the accuracy of this information. Use of a term in this book should not be regarded as affecting the validity of any trademark or service mark.

# CONTENTS

## About This Manual

Getting Started .....	10
Unite System .....	11
Product Overview .....	11
Applications .....	14
System Information .....	18
DECT Technology .....	18
Operating Range .....	18
Automatic Frequency and Group Management .....	19
Group ID .....	20
Using with Group ID 150-256 .....	20
Using with Group ID 1-149 .....	21
Encryption .....	21

## Safety Instructions

Use Instructions .....	24
Safety Instructions About the Devices .....	25
Chargers .....	25
Transmitters and Receivers .....	29
Access Point .....	32
General Safety Instructions .....	36
Disposal .....	36
Simplified EU Declaration of Conformity .....	36
Approvals .....	36

## Quick Operational Setup

Charging .....	40
Charging with a Unite Charger .....	40
Charging with a USB Power Adapter .....	41
Charging Indicators .....	42
Simple Initial Operation Of The Unite System .....	43
Creating A New Pairing On The Transmitters .....	46
Changing the Group ID .....	46
Setting the Channel Name .....	47
Creating A New Pairing With The Charger .....	49

Changing the Group ID with a Charging Unit .....	49
<b>Unite CC</b>	
Controls And Indicators .....	53
Top View .....	53
Rear View .....	54
Mains Connections .....	55
Establishing Pairing .....	56
Group ID .....	56
Using with Group ID 150-256 .....	56
Using with Group ID 1-149 .....	57
Changing the Group ID with a Charging Unit .....	57
Charging .....	60
Automatic Firmware Update .....	61
Conditioning The Battery .....	62
Service Mode .....	63
<b>Unite CR</b>	
Controls And Indicators .....	65
Top View .....	65
Rear View .....	66
Rack Mounting .....	67
Mains Connections .....	68
Establishing Pairing .....	69
Group ID .....	69
Using with Group ID 150-256 .....	69
Using with Group ID 1-149 .....	70
Changing the Group ID with a Charging Unit .....	70
Charging .....	73
Automatic Firmware Update .....	74
Conditioning The Battery .....	75
Service Mode .....	76
<b>Unite CDD, CDS And DS</b>	
Controls And Indicators .....	78
Top View .....	78
Rear View .....	80
Mounting The Chargers On A Table .....	82
Bottom of Unite CDD-8/4 .....	82
Bottom of Unite CDS-4/2 and Unite DS-4/2 .....	83
Mains Connections .....	84

Establishing Pairing .....	85
Group ID .....	85
Using with Group ID 150-256 .....	85
Using with Group ID 1-149 .....	86
Change the Group ID .....	86
Charging .....	90
Automatic Firmware Update .....	92
Conditioning The Battery .....	93
Reset Factory Settings Of The Charger .....	94
Service Mode .....	95

## Unite TP

Description .....	97
Device .....	97
Status Indicator .....	99
Display .....	100
How To Wear The Bodypack Transmitter .....	103
Neck Strap .....	103
Belt Clip .....	104
Connections .....	105
Connecting Headphones / Headset / Induction Loop .....	105
Connecting a Microphone .....	106
Connecting an External Audio Source .....	107
Operation .....	108
General Operation Process .....	108
Switching On or Off .....	109
Adjusting the Volume .....	110
Mute Function .....	111
Bluetooth® Interface .....	113
Pairing .....	114
Creating a Pairing .....	114
Encryption .....	115
Group ID .....	116
Using with Group ID 150-256 .....	116
Using with Group ID 1-149 .....	117
Changing the Group ID .....	117
Setting the Channel Name .....	118
Using As A Sub-Master .....	121
Configuring a Sub-Master .....	121
Connecting a Sub-Master to a Master .....	122

Using With A Unite AP4 Access Point .....	123
Configuring As AP4 Mic (Sub-Master) .....	123
Connecting to a Unite AP4 Master .....	123

## Unite TH

Description .....	125
Device .....	125
Status Indicator .....	126
Display .....	128
Handling .....	130
General Operation .....	131
Microphone Gain And Noise Suppression .....	132
How to Use the ALC Function .....	132
Manual Adjustment of the Microphone Gain Without Using ALC .....	134
Compressor and Noise Gate .....	135
Bluetooth® Interface .....	137
Pairing .....	138
Creating a Pairing .....	138
Encryption .....	139
Group ID .....	140
Using with Group ID 150-256 .....	140
Using with Group ID 1-149 .....	141
Changing the Group ID .....	141
Setting the Channel Name .....	142
Using As A Sub-Master .....	145
Configuring a Sub-Master .....	145
Connecting a Sub-Master to a Master .....	146
Using With A Unite AP4 Access Point .....	147
Configuring As AP4 Mic (Sub-Master) .....	147
Connecting to a Unite AP4 Master .....	147
Maintenance .....	148
Cleaning .....	148
Replacing the Colored Ring .....	149

## Unite RP / RP-T

Description .....	152
Device .....	152
Status Indicator .....	153
Display .....	155
How To Wear The Bodypack Receiver .....	157
Neck Strap .....	157

Belt Clip .....	158
Operation .....	159
General Operation Process .....	159
Connecting Headphones / Headset / Induction Loop .....	160
Switching On or Off .....	161
Adjusting the Volume .....	162
Speaking to the Guide (RP-T Only) .....	163
<b>Unite AP4</b>	
Description .....	166
Front View .....	166
Rear View .....	166
Installation .....	168
Mounting to a Wall / Ceiling .....	168
Mounting on a Stand .....	171
Mounting on a VESA Adapter Plate .....	174
Using a Secondary Safety Rope .....	177
Using Multiple Unite AP4 .....	178
<b>Menu Items</b>	
General Menu Items .....	180
Audio Main Menu .....	182
Basic Audio Settings .....	182
Set Input Effects .....	184
Talkback Main Menu .....	190
Bluetooth Main Menu .....	192
System Main Menu .....	194
<b>Special Features</b>	
Channel Search .....	199
External Interfaces .....	201
Device Mode / Sub-Master Configuration .....	202
Talkback Function (RP-T Only) .....	203
Number Of open Microphones .....	205
<b>Special Functions</b>	
Button Lock .....	207
Unite RP, RP-T, TP .....	207
Unite TH .....	207
Automatic Headset Recognition (TP, RP-T) .....	209
Automatic Power Off .....	210

## Troubleshooting

Unite Chargers .....	212
Unite Bodypack Receivers .....	215
Unite AP4 .....	219



# ABOUT THIS MANUAL

This chapter will give you a short introduction to this manual and a general description of the Unite system, its applications and its main features.

# GETTING STARTED

Throughout this guide we use different icons to designate different types of information:



This is a note. A note gives additional information, such as the meaning of the color of a LED. A note also provides information that may only be applicable to some situations.



This is a tip. A tip gives you an alternative way to do a particular step or procedure, or lets you know of an option that you may find helpful.



This is a warning. A warning indicates that something is very important or something you need to do in order to accomplish a certain task.



This is a safety precaution. A safety precaution provides information that you need to be careful about to prevent potential problems when using our systems.

# UNITE SYSTEM

Unite is a digital wireless communication system that allows people to communicate and interact with each other in a wide range of applications such as guided tours, wireless presentations, assistive listening and blind coverage, education, interpretation and language distribution.

This wireless transmission platform in DECT standard means the system can be used without certification and licence fees. The frequencies, that are region-dependent, do not need to be managed as the system itself automatically controls robust and encrypted transmission. This allows up to 32 groups to be integrated in parallel, and its wide operating range and long operating time offer completely stable transmission conditions.

## Product Overview

The Unite system consists of the following elements:

### DIGITAL TRANSMITTERS

The Unite digital transmitters are used in conjunction with bodypack receivers. They can also be used as a wireless microphone system, as well as for multilingual interpretation and assistive listening applications.



Unite TP



Unite TH

## DIGITAL RECEIVERS

The Unite digital bodypack receivers are ideal for guided tours, whisper interpreting and inclusivity (assistive listening, blind coverage/audio description). There is even an integrated microphone and talkback function to allow dialogue with a group (Unite RP-T only).



Unite RP



Unite RP-T

## ACCESS POINT

For fixed installations, you can replace the Unite TP or Unite TH transmitter with a Unite AP4. This point access can offers 4 channels with a very high transmission range and a Dante audio interface. Up to 8 access points can be synchronized for up to 32 audio channels.



Unite AP4

## TRANSPORT & CHARGING

The Unite chargers are multifunctional devices that can be used not only to store and charge the transmitters and receivers, but also to relay pairing information.



Unite CC-28/2 Cockpit Case



Unite CC-36/2 Cockpit Case



Unite CR-12P Cockpit Rack



Unite DS-4/2 Desktop Charger



Unite CDS-4/2 Desktop Charger



Unite CDD-8/4 Desktop Charger

## Applications

The diagrams below show a few examples of the possible application setups that can be achieved with a Unite system:

## Guided Tours:

# UNITE

GUIDED TOUR WITH TALKBACK

### Guide

Master



Unite TP + HSP321

### Visitors

Receiver with Talkback

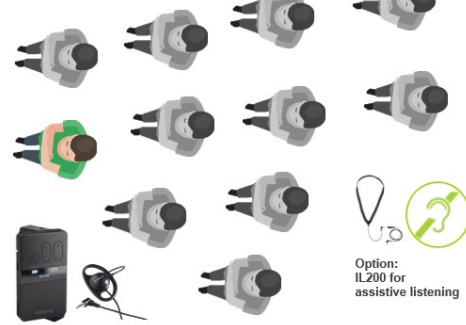

Unite RP-T + EP152



Option:  
IL200 for  
assistive listening

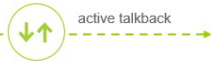

Talkback can be routed by the Master device to:

1. ALL = the whole group
2. Master device only
3. Master and all Sub-Master devices

#### DECT Connections

⌋ Broadcast

↕ Full-Duplex

## Wireless Microphone:

# UNITE NETWORK

CHANNEL WIRELESS MICROPHONE

### Stage

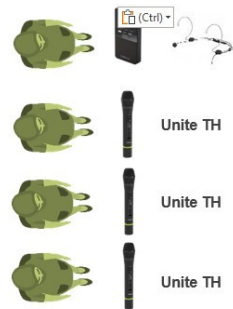

Unite TH

Unite TH

Unite TH

Unite TH

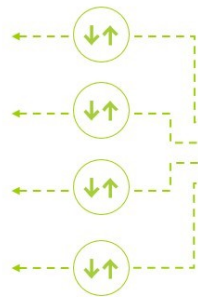

Unite AP4  
Master  
FULL-  
DUPLEX



### Audience

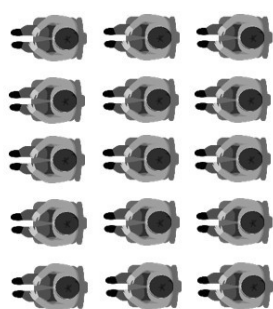

↔ Dante (PoE)  
→ analog

#### DECT Connections

↕ Full-Duplex

**Interpretation:**

# UNITE

INTERPRETATION – BROADCAST OF 4 LANGUAGES



## Audience

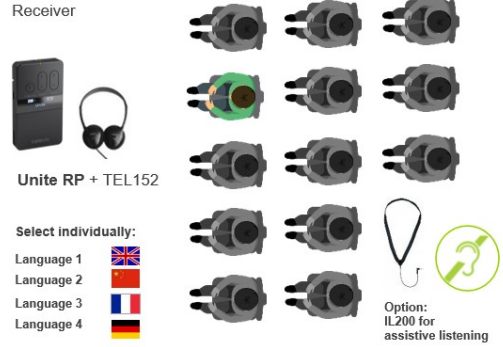

DECT Connections



**Assistive Listening:**

# UNITE

SMALL EVENT WITH ASSISTIVE LISTENING (WITHOUT PA)

## Speaker



## Audience



DECT Connections





## Blind Coverage:

# UNITE

BLIND COVERAGE – WITH TWO REPORTER AND MONITORING

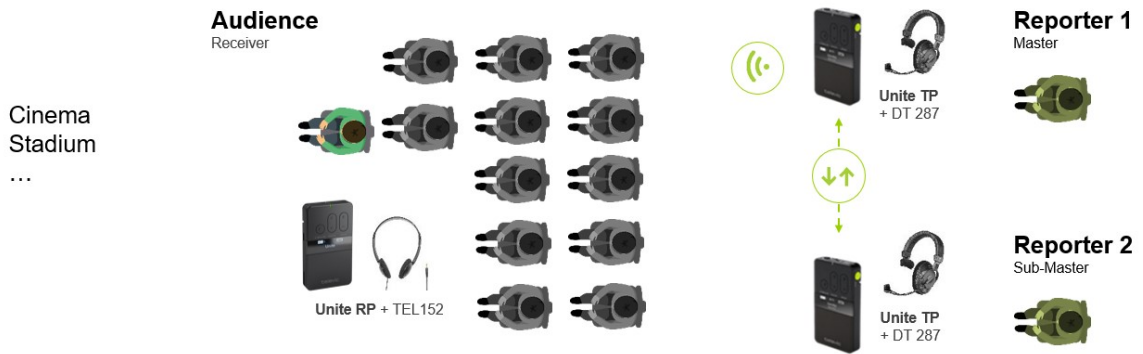

Sub-Master signal can be routed by the Master device to:

1. ALL = the whole group
2. Master device only
3. Master and all Sub-Master devices

DECT Connections

📶 Broadcast

↕ Full-Duplex

## Education:

# UNITE

HYBRID LEARNING WITH HEADSETS FOR ONE SPEAKER AND PARTICIPANTS ON SITE

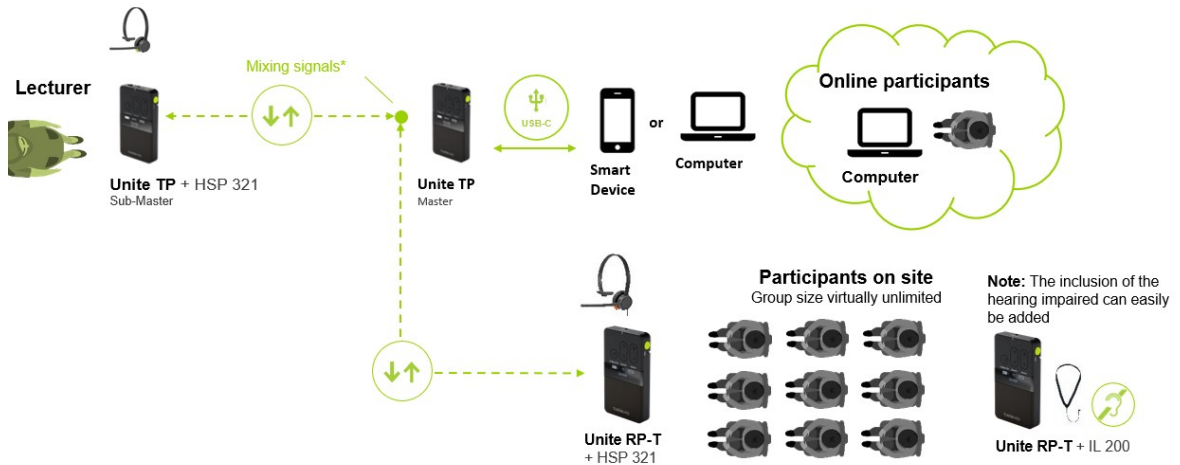

\* Unite Master device mixes and routs audio signals

DECT Connections

📶 Broadcast

↕ Full-Duplex

# SYSTEM INFORMATION

## DECT Technology

Unite is based upon **DECT** (Digital Enhanced Cordless Telecommunications) technology, an international standard for telecommunications using wireless technology, and known in particular for its use with cordless telephones. Wireless technology enables a device to **communicate with a central processing unit**.

The modern, future-proof transmission platform in DECT standard means the system can be used worldwide **without registration and free of charge**. In addition, DECT systems offer outstanding **security** as for each connection the receiver is required to register with the transmitter using a confidential code. Below 2.4 GHz, DECT uses different frequencies to WLAN, Bluetooth®, etc. and therefore causes no interference with these networks.

## Operating Range

Unite is able to **bridge very great distances between the various device types**. Peak values up to 300 m can be achieved in open areas. There are various influencing factors inside buildings. Operating range is restricted by the number and composition of walls, ceilings and floors. Performance is inevitably restricted as a result of absorption and reflection of the high frequency range. For example, reinforced concrete absorbs frequencies to a certain extent, whereas a metal-clad ceiling reflects them.

A further influencing factor is the **number of active DECT wireless connections** conditional upon the frequency band available in each region. In Europe, for example, a maximum of 120 channels can be in use, whereas the maximum for the American market is 60 channels. The total number of connected devices can be much higher than these key indicators, however, since they relate only to the number of simultaneously used DECT radio connections actively occupying a channel.

Actual restriction of the system is generally only to be expected when all influencing factors occur at once. For example: in one area of a building, there are 70 simultaneously active DECT telephones; in this same part of the building there are 32 Unite groups, the transmitters of which are attempting to reach their groups through several walls simultaneously. The walls are made of reinforced concrete and all ceilings are metalclad.

## Automatic Frequency and Group Management

A further benefit of this technology is automatic frequency management. This means you need not worry about frequencies, as **the system itself controls transmission and adjusts automatically for secure transmission**. It recognises the availability and allocation of frequencies and adjusts dynamically and automatically. Interference signals are identified at an early stage, enabling the system to react immediately.

Without the knowledge of the user and/or listener, it switches frequency to ensure **uninterrupted operation**.

The system also identifies all active wireless connections and adapts these dynamically so that individual groups do not interfere with each other. This means Unite can be used in parallel by **up to 32 groups**.

A high operating range and long operating time create stable conditions for transmission.

DECT frequency range		Free of charge and no registration required in
1880 - 1900 MHz	EU	Australia, Austria, Belgium, Bulgaria, Croatia, Cyprus, Czech Republic, Denmark, Estonia, Finland, France, Germany, Great Britain, Greece, Hong Kong, Hungary, Ireland, Israel, Italy, Jordan, Latvia, Lithuania, Luxembourg, Malaysia, Malta, Moldavia, Netherlands, New Zealand, Norway, Poland, Portugal, Romania, Russia, Singapore, Slovakia, Slovenia, South Africa, Spain, Sweden, Switzerland, United Arab Emirates
1893 – 1906 MHz	Japan	Japan
1920 – 1930 MHz	North America	Canada, USA

For other countries: please contact Televic Conference.



All devices are supplied with the group **ID 256** and **fixed audio encryption** allowing quick and easy setup. This allows for quick and easy initial use.

The group ID identifies devices that can be placed in a virtual group. For example, all devices within a building, a tour group or a conference room. The transmitter will only transmit the audio signal to a channel with a predefined channel name. If there are several transmitters in a group, the channel for the respective transmitter can be selected on the receiver. You will need to establish a new pairing if you require several device groups or secure audio transmission that cannot be intercepted by another group using Unite devices. The factory preset group ID is 256.

If you want to set a group ID between 1 and 255, please read the sections below or refer to the Pairing section of your device(s) in this manual.

## Group ID

The group ID refers to devices that can be combined to a virtual group. For example, all devices of a building, a travel group or a conference room.

## Using with Group ID 150-256

**By default**, the transmitters and receivers are supplied with the group **ID 256**. A common factory-set audio encryption key, which cannot be changed, is used for the group ID range of 150 to 256.

The audio encryption key ensures **additional security** against unauthorised listening during the wireless transmission. Due to the factory-set audio encryption key the devices within the group ID range of 150 to 256 can connect to each other without pairing via the charger. In this case receivers can connect to transmitters via the dynamic channel search.

Example: Via the dynamic channel search, a receiver which is set to the group ID 160 will find all transmitters which are active and also set to the group ID 160. The receiver will not find transmitters beyond the set ID range of 160.



When using **several transmitters** (e.g. Unite AP4 and several Unite TP) with the same group ID at the same time, make sure that the individual channel names differ from each other! Otherwise this can cause connection problems with the receivers!

## Using with Group ID 1-149

If several receivers are to be divided into different groups with an individual encryption, for each group an individual group **ID between 1 and 149** can be assigned. A **separate audio encryption key is generated** for an individual group ID in order to ensure additional security against unauthorized listening during the wireless transmission. This audio encryption key is generated during the pairing process, stored in the charger and transmitted from the charger to the transmitter and receiver, along with the channel name and group ID.

The receivers can only connect to a transmitter with which they have been paired via the charger. If the group ID is subsequently set manually on a receiver which has not been paired, no connection can be established to the transmitter with the encrypted group ID, because the receiver does not have the audio encryption key.

## Encryption

The audio data is always encrypted with an AES-256 code to ensure a secure transmission against unauthorized listening.



The required key will be generated within the charging unit itself and transmitted to the transmitters and receivers during the pairing process.

As the encryption code is not transmitted wirelessly, the system is better protected against unauthorized listening. Should the receiver receive a differently encrypted audio signal for which no encryption code has been saved, the received audio signal will be muted. The receiver display will also alternate between showing the relevant channel name and the "KEY!" error message.

The encryption of the audio signal is explained schematically in the "Encryption" diagram below.

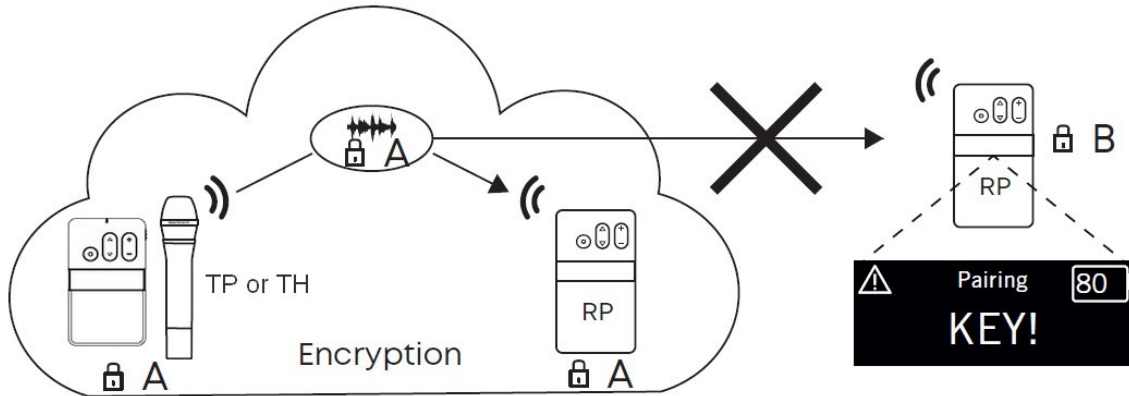

The group IDs in the range of 150 to 256 uses a factory-defined key that cannot be changed. You can use this group ID for a system without pairing.



The transmitter and receiver can only communicate if the settings for group ID, channel name and encryption match. Transmitters cannot communicate with receivers that do not have the same pairing information.



If you need a specific encryption key, you need to use a group ID between the range of 1 and 149. Refer to the **Pairing** section of your device to change the group ID.

# SAFETY INSTRUCTIONS

This chapter will describe all safety instructions needed to use the Unite system. Read this before using the equipment.

# USE INSTRUCTIONS

You have purchased the Unite digital wireless Unite communication system from Televic. Thank you for your trust.

The safety instructions contain general safety guidelines that integrators, installers, operators, end users, and anyone else who installs or uses Televic material is required to read and follow at all times.

All Televic systems are state of the art devices and have been designed to meet all quality standards. Nevertheless, the individual components of the system can cause danger for persons and material assets if:

- › the system is not used as intended,
- › the system is set up by personnel not familiar with the safety regulations,
- › the system is converted or altered incorrectly,
- › the safety instructions are not observed.

Before using the equipment, make sure to:

- › Read the user manual before the first use,
- › Keep the user manual,
- › Follow the specified operating and safety instructions.

Televic will not be liable for any damage to the product or injury to persons caused by negligent, improper, incorrect or inappropriate operation of the product.



# SAFETY INSTRUCTIONS ABOUT THE DEVICES

## Chargers

These safety instructions are applicable to the following Unite chargers: Unite CC-28/2, Unite CC-36/2, Unite CR-12P, Unite DS-4/2, Unite CDS-4/2 and Unite CDD-8/4.

### Power Connections:

For permanently connected equipment, a readily accessible disconnect device shall be incorporated in the fixed wiring; For pluggable equipment, the socket-outlet shall be installed near the equipment and shall be easily accessible.



This label may appear on the bottom of the apparatus due to space limitations.



The lightning flash with an arrowhead symbol, with an equilateral triangle, is intended to alert the user to the presence of un-insulated 'dangerous voltage' within the products enclosure that may be of sufficient magnitude to constitute a risk of electric shock to persons.



The exclamation mark within an equilateral triangle is intended to alert the user to the presence of important operating and maintenance (servicing) instructions in the literature accompanying the appliance.

- › Read these instructions.
- › Keep these instructions.
- › Heed all warnings.
- › Follow all instructions.
- › Do not use this apparatus near water.
- › Clean only with dry cloth.
- › Do not block any ventilation openings. Install in accordance with the manufacturer's instructions.
- › Do not install near any heat sources such as radiators, heat registers, stoves, or other apparatus (including amplifiers) that produce heat.
- › Do not defeat the safety purpose of the polarized or grounding-type plug. A polarized plug has two blades with one wider than the other. A grounding type plug has two blades and a third grounding prong. The wide blade or the third prong are provided for your safety. If the provided plug does not fit into your outlet, consult an electrician for replacement of the obsolete outlet.
- › Protect the power cord from being walked on or pinched particularly at plugs, convenience receptacles, and the point where they exit from the apparatus.
- › Only use attachments/accessories specified by the manufacturer.
- › Use only with the cart, stand, tripod, bracket, or table specified by the manufacturer, or sold with the apparatus. When a cart is used, use caution when moving the cart/apparatus combination to avoid injury from tip-over.
- › Unplug this apparatus during lightning storms or when unused for long periods of time.
- › Refer all servicing to qualified service personnel. Servicing is required when the apparatus has been damaged in any way, such as power supply cord or plug is damaged, liquid has been spilled or objects have fallen into the apparatus, the apparatus has been exposed to rain or moisture, does not operate normally, or has been dropped.

**Location:**

- › The equipment must be set up so that the mains switch, mains plug and all connections on the rear of the device are easily accessible.
- › If you transport the equipment to another location take care to ensure that it is adequately secured and can never be damaged by being dropped or by impacts on the equipment.

**Fire Hazard:**

- › Never place naked flames (e.g. candles) near the equipment.

**Humidity / Heat Sources:**

- › Never expose the equipment to rain or a high level of humidity. For this reason do not install it in the immediate vicinity of swimming pools, showers, damp basement rooms or other areas with unusually high atmospheric humidity.
- › Never place objects containing liquid (e.g. vases or drinking glasses) on the equipment. Liquids in the equipment could cause a short circuit.
- › Do not install near any heat sources such as radiators, heat registers, stoves or other device (including amplifiers) that produce heat.

**Connection:**

- › The equipment must be connected to a mains socket that has an earth contact.
- › Protect the power cord by not walking or standing on it or pinching, this is considered for plugs especially where they exit from the device.
- › Lay all connection cables so that they do not present a trip hazard.
- › Whenever working on the equipment switch off all inputs and outputs to the power supply.
- › Check whether the connection figures comply with the existing mains supply. Serious damage could occur due to connecting the system to the wrong power supply. An incorrect mains voltage could damage the equipment or cause an electric shock.
- › Please note that different operating voltages require the use of different types of power cable and plugs. Please refer to the following table:

Voltage	Power plug according to standard
110 - 125 V	UL817 and CSA C 22.2 no. 42
220 - 230 V	CEE 7 page VII, SR section 107-D1/EC 83 page C4
240 V	BS 1363 (1984): "Specification for 13A fused plugs and switched and unswitched socket outlets."

- › If the equipment causes a blown fuse or a short circuit, disconnect it from the mains and have it checked and repaired.

- › Do not hold the mains cable with wet hands. There must be no water or dust on the contact pins. In both cases you could receive an electric shock.
- › The mains cable must be firmly connected. If it is loose there is a fire hazard.
- › Always pull out the mains cable from the mains and/or from the equipment by the plug – never by the cable. The cable could be damaged and cause an electric shock or fire.
- › Do not use the equipment if the mains plug is damaged.
- › If you connect defective or unsuitable accessories, the equipment could be damaged. Only use connection cables available from or recommended by Televic.

**Switching Off:**

- › When switching off the device, also disconnect the power plug from the power socket. Make sure that you do not pull on the cable, but on the power plug.

**Disconnection:**

- › For pluggable equipment, the socket-outlet shall be near the equipment and shall be easily accessible.

**Ventilation:**

- › Do not insert objects into the ventilation grilles or other openings. You could damage the equipment and/or injure yourself.

**Maintenance:**

- › Only clean the equipment with a slightly damp or dry cloth. Never use solvents as these damage the surface.

**Troubleshooting and Servicing:**

- › Never open the device yourself.
- › Leave all service work to authorised expert personnel.

**Charging:**

- › A completely new battery may need to be charged and discharged several times before it has reached its full charge capacity.

- › Do not throw used batteries in the household waste, but hand them over to the local collection points.
- › High ambient temperatures during charging (> +40 °C) affect the efficiency of the charging process and the lifetime of the rechargeable battery.

## Transmitters and Receivers

These safety instructions are applicable to the Unite TP and Unite TH transmitters, as well as to the Unite RP and Unite RP-T receivers.

### General:

- › Protect the transmitter/receiver from moisture and sudden impacts. You could either injure yourself or others or damage the transmitter/receiver.

### Troubleshooting and Servicing:

- › Never open the device yourself.
- › Leave all service work to authorised expert personnel.

### Maintenance:

- › Only clean the equipment with a slightly damp or dry cloth. Never use solvents as these damage the surface.

### Rechargeable Battery:



The transmitter/receiver is operated with the following battery type: BAT-3707, lithium-ion, 3.7 V, 1.88 Ah, 6.96 Wh.



Use only a USB 2.0/3.0 compliant 5V power supply to charge the battery pack via the integrated USB type-C port (power consumption is max. 500 mA).



High temperatures, particularly in association with a high charging status, result in irreversible damage of the battery pack.

- › If you are not intending to use the battery for an extended period or are planning to put it into storage, it is advisable to lower the battery's charging level to around 50% and to store it at temperatures of maximum 30 °C.
- › In order to ensure safe transport by land, sea and air, the battery pack used for the bodypack transmitter is tested according to the UN 38.3 transport regulation for lithium-ion batteries.
- › Misuse or improper use could damage the battery pack. In extreme cases, there is a risk of explosion, heat, fire, smoke or gas.
- › Never expose the battery pack to excessive heat such as sunshine, fire or the like.
- › Do not expose the battery pack to mechanical shock.
- › Charge the battery pack before initial use.
- › Use the specified chargers for charging the battery pack.
- › Avoid complete draining of the battery. This could damage the battery and shorten its service life.
- › If you do not use the transmitter for several months, the batteries should be charged at least twice a year to prevent deterioration in performance due to self-discharge.
- › Clean the charging contacts of the transmitter with a clean dry cloth, if they become dirty.
- › Do not short-circuit the battery.
- › The charging contacts could cause property damage, injuries or fire damage if they come into contact with conductive materials such as jewellery, keys or chains. This can lead to a closed electric circuit and, therefore, to the material overheating. To avoid this kind of unintentional electric circuit, the charging contacts must be handled with care. This is especially important if the transmitter is transported in a bag or another container containing other metallic objects.

#### **Humidity / Heat Sources:**

- › Keep the battery pack clean and dry. Never expose the device to rain or high humidity. Do not install it in the immediate vicinity of swimming pools, shower facilities, damp basements or other areas with unusually high air humidity.

- › Never place objects filled with water (e.g. vases or drinking glasses) on the device. Liquids in the devices may cause a short circuit.
- › Never install or operate the device in the immediate vicinity of radiators, lighting systems or other heat-generating devices.

**Volume:**

- › When using headphones/headsets, make sure that the volume is set to minimum. Adjust the volume only after putting on the headphones/ headset. Too high volumes and too long listening times can damage your hearing. Hearing damage always represents an irreversible impairment of hearing.
- › Always pay attention to the volume. As a rule of thumb, the higher the volume, the shorter the listening time. By law, the maximum allowed value is 85 dB at a maximum listening time of 8 hours.
- › Temporary symptoms that you have been exposed to loud noise are:
  - › ringing or whistling in the ears
  - › high tones can no longer be perceived.

**Unite TH Handheld Transmitter:**

- › Do not blow into the microphone. In a condenser microphone this could damage the transformer. It is preferable to carry out a speech trial.

**Unite TP Bodypack Transmitter:**

- › Clip-on microphones are often very compact. If they are accidentally swallowed there is a risk of choking. Always keep this type of microphone away from small children.

**Unite RP / RP-T Bodypack Receiver:**

- › The supplied strap is only used for wearing the device around the neck. If it is not used correctly, the risk of strangulation may occur.

**Trademark:**

- › The Bluetooth® word mark and logos are registered trademarks of Bluetooth SIG, Inc. and all use of these trademarks by Televic is licensed. Other trademarks and trade names are the property of the respective owners.

## Access Point

These safety instructions are applicable to the Unite AP4 Access Point.

### **General:**

1. Read these instructions.
2. Keep these instructions.
3. Heed all warnings.
4. Follow all instructions.
5. Do not use this device near water.
6. Clean only with a dry cloth.
7. Do not install near any heat sources such as radiators, heat registers, stoves, or other apparatus (including amplifiers) that produce heat.
8. Do not modify the power plug of the supplied power cable.
9. Protect the power cable from being pinched or bent.
10. Only use accessories specified by the manufacturer.
11. Unplug this apparatus during lightning storms or when unused for long periods of time.
12. Refer all servicing to qualified service personnel. Servicing is required when the apparatus has been damaged in any way, such as power supply cord or plug is damaged, liquid has been spilled or objects have fallen into the apparatus, the apparatus has been exposed to rain or moisture, does not operate normally, or has been dropped.

### **Location:**

- › If you transport the equipment to another location take care to ensure that it is adequately secured and can never be damaged by being dropped or by impacts on the equipment.



**Fire Hazard:**

- › Never place naked flames (e.g. candles) near the equipment.

**Humidity / Heat Sources:**

- › Never expose the equipment to rain or a high level of humidity. For this reason do not install it in the immediate vicinity of swimming pools, showers, damp basement rooms or other areas with unusually high atmospheric humidity.
- › Never place objects containing liquid (e.g. vases or drinking glasses) on the equipment. Liquids in the equipment could cause a short circuit.
- › Do not install near any heat sources such as radiators, heat registers, stoves or other apparatus (including amplifiers) that produce heat.

**Connection:**

- › Protect all cables from being walked on or pinched.
- › Lay all connection cables so that they do not present a trip hazard.
- › Whenever working on the inputs and outputs of the equipment switch off power.
- › Check whether the connection figures comply with the existing mains supply. Serious damage could occur due to connecting the system to the wrong power supply. An incorrect mains voltage could damage the equipment or cause an electric shock.
- › Please note that different operating voltages require the use of different types of power cable and plugs. Please refer to the following table:

Voltage	Power plug according to standard
110 - 125 V	UL817 and CSA C 22.2 no. 42
220 - 230 V	CEE 7 page VII, SR section 107-D1/EC 83 page C4
240 V	BS 1363 (1984): "Specification for 13A fused plugs and switched and unswitched socket outlets."

- › If the equipment causes a blown fuse or a short circuit, disconnect it from the mains and have it checked and repaired.
- › Do not hold the power supply with wet hands. There must be no water or dust on the contact pins. In both cases you could receive an electric shock.

- › The mains cable must be firmly connected. If it is loose there is a fire hazard.
- › Always pull out the power supply from the mains and/or from the equipment by the plug – never by the cable. The cable could be damaged and cause an electric shock or fire.
- › Do not use the equipment if the power supply is damaged.
- › If you connect defective or unsuitable accessories, the equipment could be damaged. Only use connection cables available from or recommended by Televic. If you use cables you have made up yourself, all claim to warranty is null and void.
- › In order to switch off the device disconnect the power plug from the power socket.

**Switching Off:**

- › The device does not have a separate on-off switch. To turn power off, unplug the power cable from the AC/DC outlet. Make sure that you do not pull on the cable, but on the mains plug.

**Disconnection:**

- › For pluggable equipment, the socket-outlet shall be near the equipment and shall be easily accessible.

**Wall / Ceiling Mounting:**

- › Before mounting the Unite AP4 to the wall/ceiling, make sure that there are no electrical, or gas lines or water pipes behind the planned drilling locations. If necessary, check this with a line detector or ask an expert.
- › It is a significant hazard when electrical or gas lines or water pipes are damaged during drilling.

**Maintenance:**

- › Only clean the device with a slightly damp or dry cloth. Never use solvents as these damage the surface.

**Troubleshooting and Servicing:**

- › Do not open the device without authorization.
- › Leave all service work to authorized expert personnel.

**Ventilation:**

- › Do not insert objects into the ventilation and other openings. You could damage the device and/or injure yourself.

**Measures to Prevent Damage:**

- › Do not disassemble or make any changes to the device.
- › Do not transport the device while it is mounted on a tripod as this may result in injury or accidents. Make sure that the tripod is solid enough to hold the device.
- › Do not drop the unit and do not expose it to strong physical stress such as shock or vibration.

# GENERAL SAFETY INSTRUCTIONS

## Disposal



At the end of its operating life this product may not be disposed of along with normal household waste. Please take it to a designated recycling point for electric and electronic appliances. This is indicated by the symbol on the product, the operating instructions or the packaging.

## Simplified EU Declaration of Conformity

Televic hereby declares that the wireless transmission device complies with the EU Directive 2014/53/EU (RED). The complete text of the EU declaration of conformity is available online at the following address:

<https://conference.televic.digital/knowledgebase/products/unite/>

## Approvals

This device complies with Part 15 of the FCC Rules and with Industry Canada licence-exempt RSS standard(s). Operation is subject to the following two conditions:

- (1) this device may not cause harmful interference, and
- (2) this device must accept any interference received, including interference that may cause undesired operation.

Le présent appareil est conforme aux CNR d'Industrie Canada applicables aux appareils radio exempts de licence. L'exploitation est autorisée aux deux conditions suivantes:

- (1) l'appareil ne doit pas produire de brouillage, et
- (2) l'utilisateur de l'appareil doit accepter tout brouillage radioélectrique subi, même si le brouillage est susceptible d'en compromettre le fonctionnement.

This equipment has been tested and found to comply with the limits for a Class A digital device, pursuant to Part 15 of the FCC Rules. These limits are designed to provide reasonable protection against harmful interference when the equipment is operated in a commercial environment. This equipment generates, uses, and can radiate radio frequency energy and, if not installed and used in accordance with the instruction manual, may cause harmful interference to radio communications. However, there is no guarantee that interference will not occur in a particular installation. If this equipment does cause harmful interference to radio or television reception, which can be determined by turning the equipment off and on, the user is encouraged to try to correct the interference by one or more of the following measures:

- › Reorient or relocate the receiving antenna
- › Increase the separation between the equipment and receiver
- › Connect the equipment into an outlet on a circuit different from that to which the receiver is connected
- › Consult the dealer or an experienced radio/TV technician for help
- › Consult the Federal Communications Commission's manual "How to Identify and Resolve Radio-TV Interference Problems"

Changes or modifications made to this equipment not expressly approved by Televic may void the FCC authorization to operate this equipment.

Radiofrequency radiation exposure Information:

- › For body worn operation, this equipment has been tested and meets the FCC RF exposure guidelines when used with the Televic accessories supplied or designated for this product. Use of other accessories may not ensure compliance with FCC RF exposure guidelines.

Este produto está homologado pela Anatel, de acordo com os procedimentos regulamentados pela Resolução n.º. 242/2000 e atende aos requisitos técnicos aplicados, incluindo os limites de exposição da Taxa de Absorção Específica referente a campos elétricos, magnéticos e eletromagnéticos de radiofrequência de acordo com as Resoluções n.º. 303/2002 e 533/2009.





This device is granted pursuant to the Japanese Radio Law (電波法). This device should not be modified (otherwise the granted designation number will become invalid).

**Compliance Information:**

Frequency band 1880 - 1930 MHz

Transmitter power Max. 250 mW

Country	Approval	
USA		Unite RP/RP-T (without Bluetooth®): WM7UNITEP  Unite TP (with Bluetooth®): WM7UNITEPBT  Unite TH (with Bluetooth®): WM7UNITEHBT  Unite AP4 (without Bluetooth®): WM7UNITEAP4

Country	Approval	
Canada		Unite RP/RP-T (without Bluetooth®): 7932A-UNITEP Unite TP (with Bluetooth®): 7932A-UNITEPBT Unite TH (with Bluetooth®): 7932A-UNITEHBT Unite AP4 (without Bluetooth®): 7932A-UNITEAP4
Europe		The devices conform to the EU guidelines (EMC) 2014/30/EU (LVD) 2014/35/EU (RED) 2014/53/EU as attested by the CE mark  
Japan		Unite RP/RP-T (without Bluetooth®): R: 202-JKM125 Unite TP (with Bluetooth®): R: 202-JKM124 Unite TH (with Bluetooth®): R: 202-JKM123 Unite AP4 (without Bluetooth®): R: 202-JKM122 / T: D 23-0032 202

# QUICK OPERATIONAL SETUP

This chapter will explain the first steps for the basic operational setup of your Unite system, from charging the devices to simple initial operation with one transmitter via the factory-set group ID, as well as the creation of a new pairing.

# CHARGING

Before using the Unite system for the first time, you must charge the batteries integrated in the Unite TP or Unite TH transmitters and Unite RP bodypack receiver. The charging process and relevant charge status is shown on the status light of the transmitter/ receiver.

There are two options for charging the battery: via a Unite charger or via a USB power adapter.

## Charging with a Unite Charger

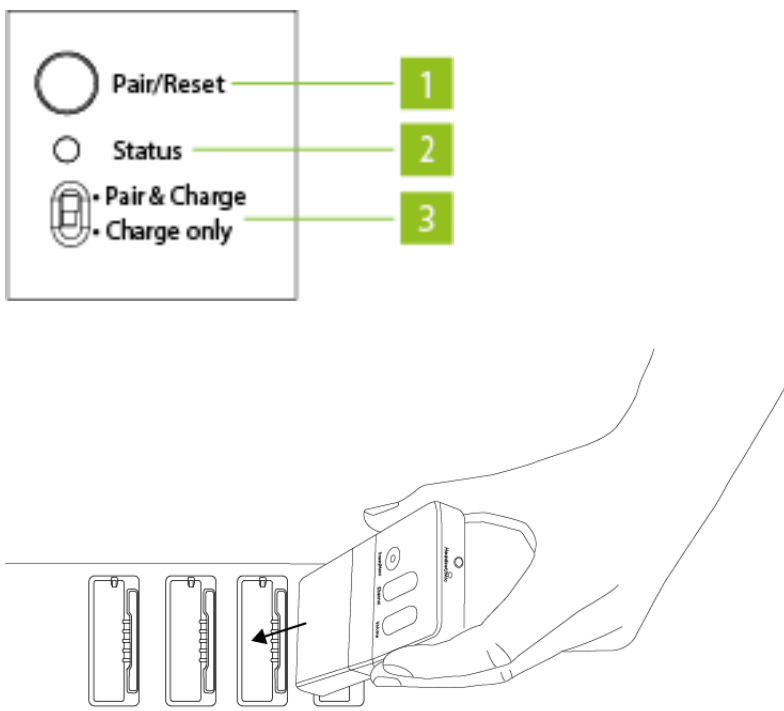

1. Connect the charger to an easily accessible power outlet.
2. Switch the charger to the position "Charge only" (3).
3. Insert the transmitter/receiver into the charging compartment. Please ensure the device is placed into the charging compartment in such a way as to ensure proper contact with the charger.
4. The charging process will start automatically.





It is not possible to use the transmitter/receiver during charging.

## Charging with a USB Power Adapter

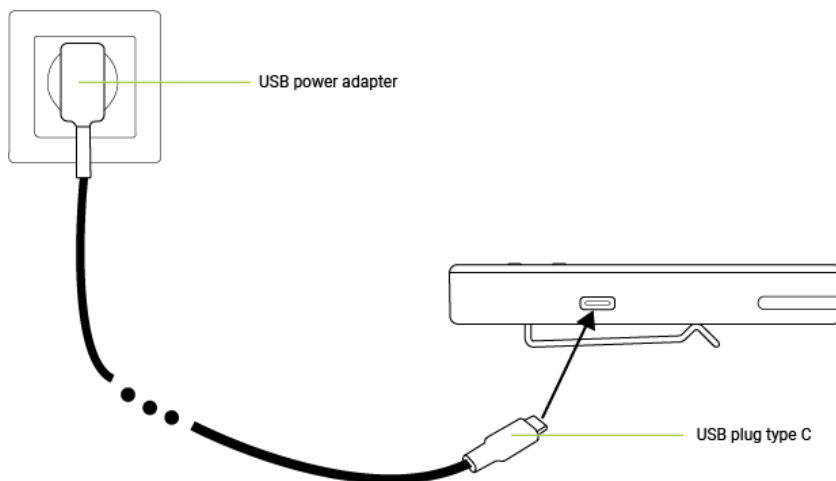

1. Connect a separate USB power adapter to the USB port on the transmitter/ receiver.



Use only a USB 2.0/3.0 compliant 5V power supply to charge the battery pack via the integrated USB type-C port (power consumption is max. 500 mA).

2. Connect the plug of the USB power adapter to a power outlet.
3. The charging process will start automatically.
4. It is not possible to use the transmitter/ receiver during charging.

## Charging Indicators

The battery's charge status is shown on the LED indicator of the relevant transmitter/receiver. See the following table:

Display	Charging status
Off	The device is switched off
Flashing green slowly	Charging mode 0–100%
Green	Battery is charged
Flashing yellow slowly	Pairing information is being copied from the transmitter
Yellow for 10 seconds	Device information successfully copied to charger/devices
Flashing red slowly for 10 seconds	<ul style="list-style-type: none"><li>• More than one transmitter in the charger at the start of the pairing process</li><li>• Other pairing errors</li></ul>
Flashing green/yellow rapidly	Device is being localised
Flashing red rapidly	Charging error

For more information about the charging devices, please refer to section of your manual corresponding to your device.

# SIMPLE INITIAL OPERATION OF THE UNITE SYSTEM

The instructions below explain how to set a simple Unite system using one transmitter and factory-set group ID (256 by default).

1. Before initial operation, charge the battery in the Unite receiver and Unite transmitter with a Unite charger. Set the switch on the Unite charger to the "Charge only" position.

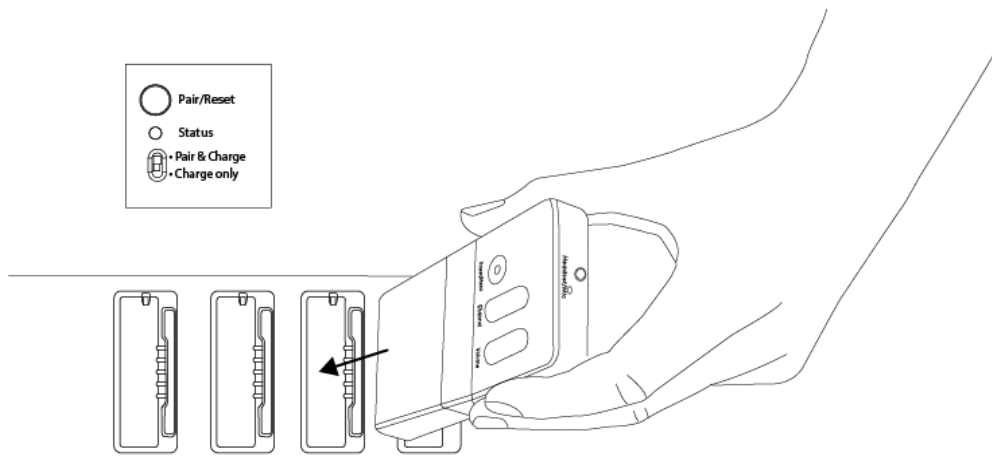

2. Connect a microphone or headset to the Unite TP bodypack transmitter.

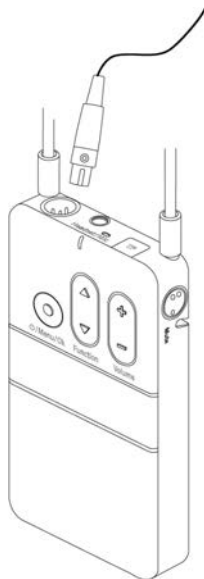

3. Connect headphones to the bodypack receiver.

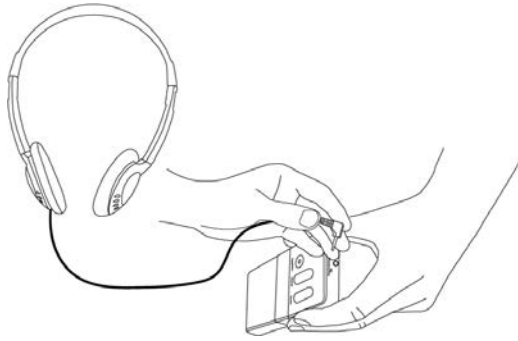

4. Switch on the bodypack transmitter or handheld transmitter by briefly pressing the **⏻/Menu/Ok** button.

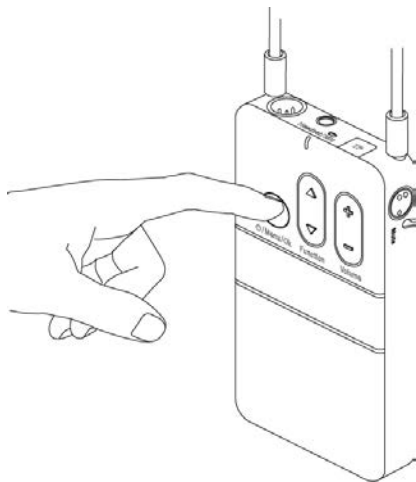

5. The status indicator on the transmitter initially lights red. Once the transmitter has found a suitable frequency, the status indicator lights green to indicate that the transmitter is ready for operation. The factory-set name "Unite" is displayed.

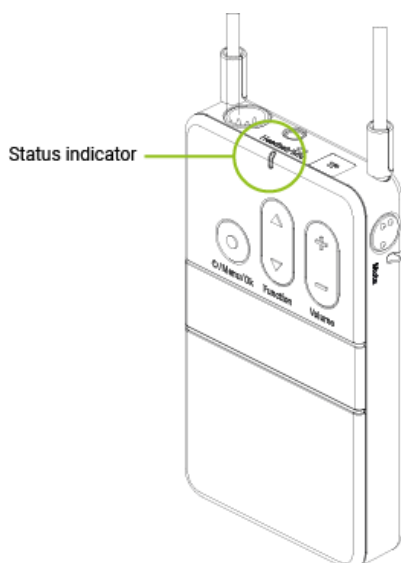

6. Switch on the receiver(s) by briefly pressing the **⏻/Menu/Ok** button.

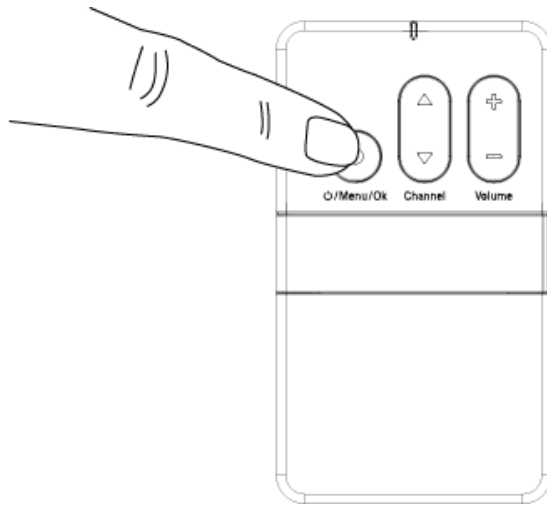

7. The status indicator on the receiver initially lights red. Once the receiver is connected to the transmitter, the status indicator lights green. The "Connecting" message on the receiver display indicates that the connection has been established. As soon as the receiver is connected to the transmitter, the name "Unite", factoryset in the transmitter, is displayed on the receiver. The Unite system is ready for operation.

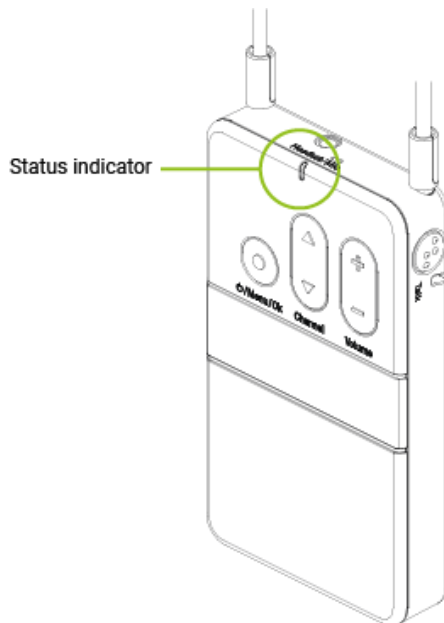

You will find a detailed description of the Unite system and its operation in the following chapters of this manual.

# CREATING A NEW PAIRING ON THE TRANSMITTERS

## Changing the Group ID

1. Press and hold the menu button for 2 seconds to activate the main menu.
2. Use the multifunction button to select "System" from the menu.
3. Press the menu button to open the required submenu.
4. Use the multifunction button to select the "Group ID" submenu.
5. Press the menu button to set an group ID.
6. Use the multifunction button to select the desired group ID.
7. Press the menu button to confirm the selected group ID.



Make sure to select the same group ID for all devices of a desired group. Only devices that have the same group ID can communicate with each other. Transmitters with other group IDs are hidden. See the following diagram.

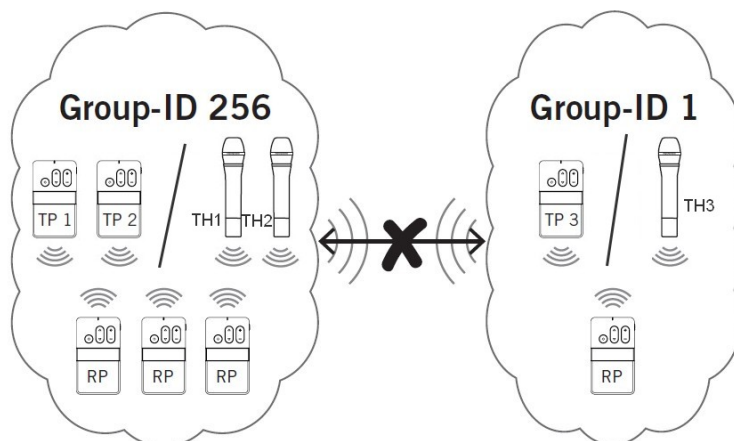

## Setting the Channel Name

Devices that are grouped with one group ID can transmit multiple audio channels via the same group ID.

In order to differentiate between audio channels from several transmitters on the receiver, enter a five-digit name for the channel on the transmitter. Proceed as described in the following:

1. Hold down the menu button on the transmitter for more than 2 seconds to activate the main menu.
2. Use the multifunction button to select "System" from the menu.
3. Press the menu button to open the required sub-menu.
4. Use the multifunction button to select the "Channel Name" sub-menu.
5. Press the menu button to set the channel name.
6. Use the multifunction button to scroll through the characters. When the desired character appears, confirm using the menu button. You can input max. five characters.

As soon as you select the configured transmitter on the receiver, the defined name will be displayed on the receiver's display.

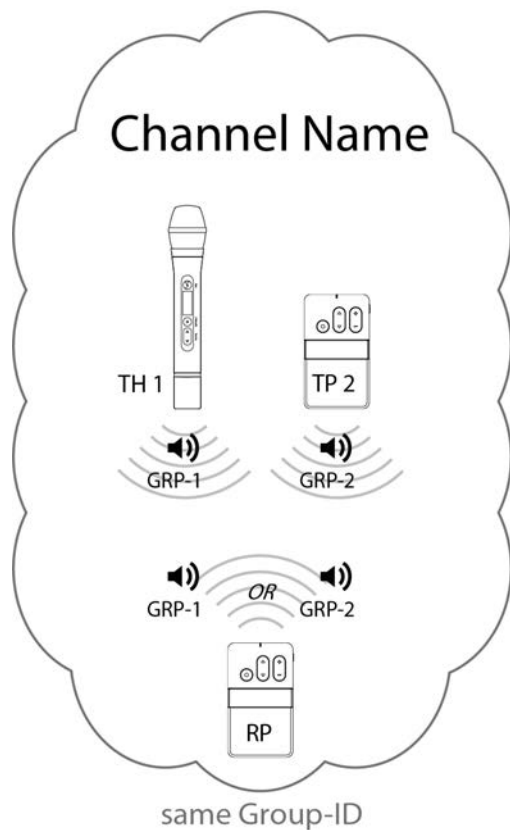





Figure 1-1 Example of two transmitters with different channel names and a receiver that can find and switch between both transmitters.

7. Change the channel on the receiver via the dynamic channel search. Press the  or  symbol of the channel buttons and confirm the displayed "Scan for channels?" question with "Yes" by pressing the menu button. Depending on the DECT environment and the distance to the transmitter, it may take several seconds to find the channels.
8. Press the  or  symbol of the channel buttons to select the transmitter (channel name). In order to confirm press the On/Off and menu button.





Once the channel search is started, the receiver will lose its connection to the previous transmitter.



# CREATING A NEW PAIRING WITH THE CHARGER

The transmitter and receiver must be paired to enable them to communicate with one another. The code required for this is generated in the charger\* and transmitted during the pairing process to both transmitter and receiver.

 \* Creating a new pairing with a Unite charger is only possible with the following models: Unite CC-28/2, Unite CC-36/2, Unite CR-12P, Unite CDS-4/2 and Unite CDD-8/4. It is not possible to use the Unite DS-4/2 charger for this purpose.

 For group ID 256 only, a factory preset code is used that cannot be changed. You can use this group ID for a system without pairing.

## Changing the Group ID with a Charging Unit

To establish a pairing with a charging unit, please proceed as described below:

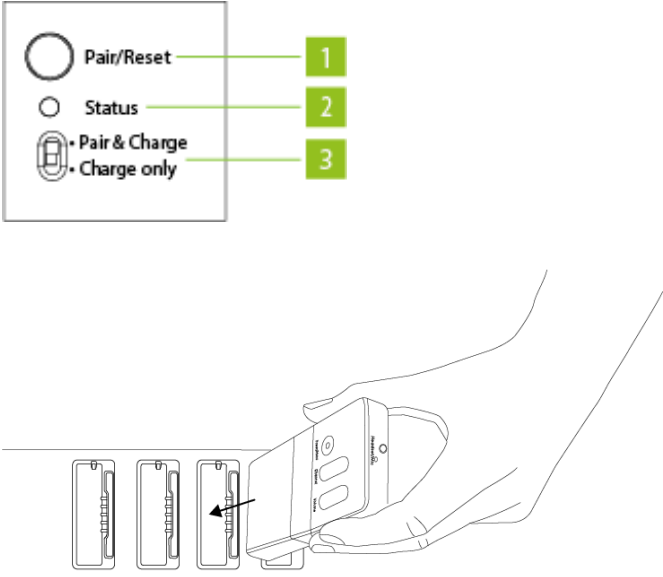

1. On the transmitter, set the group ID you wish to use for pairing.
2. Insert **one transmitter only** in the charger. If more than one transmitter is used in the charger, pairing will not start and the charger's status indicator (2) will show an error message (see table 2). Alternatively you can connect the transmitter using a USB cable connected to the charger's USB port.
3. Insert one or more receivers to be paired with the transmitter into the charger's charging compartment. You can also connect another receiver to the charger using the USB port. Remove all receivers that are not to be paired. Should no receiver be connected to the charger, pairing information is stored in the charger only. This is used for later pairing without connecting the transmitter to the charger.
4. To transmit information from the transmitter to the receivers in the charging compartments and to the charger itself for future pairings, hold down the "Pair/Reset" button (1) on the charger for more than 2 seconds. The "Status" light (2) will flash yellow for a few seconds if the pairing is successful. The status light will then remain yellow because the pairing information is now also saved in the charger.
5. If you wish to pair other receivers, remove the transmitter and all receivers from the charger, switch to "Pair & Charge" (3) and insert the unpaired receivers into the charger. The pairing information will be saved immediately in the unpaired receivers. The status light on the receiver will rapidly flash yellow while this happens.
6. If you have no further devices to pair, switch the charger to "Charge only" (3).
7. Switch on the transmitter and one receiver to check that they have both been paired successfully. After a few seconds the status light on the receiver will light up green and show the channel name of the transmitter.
8. To delete pairing information stored in the charger, hold the "Copy/Reset" button down for more than 5 seconds. The status light (2) will then remain permanently green.
9. In pairing mode (switch to "Pair & Charge"), the status light (2) on the charger will display the following information:

Display	Charging status
Off	The device is switched off
Green	<ul style="list-style-type: none"> <li>• The device is ready to use</li> <li>• No pairing information saved</li> </ul>
Flashing yellow	Pairing information is being copied to the charger or receiver
Yellow	Pairing information has been stored in the charger
Flashing green/yellow rapidly	Device is being localised
Flashes red 5 times	<ul style="list-style-type: none"> <li>• No transmitter</li> <li>• Too many transmitters</li> </ul>
Flashing red rapidly	<ul style="list-style-type: none"> <li>• Operating error</li> <li>• Charging error</li> </ul>

# UNITE CC

The Unite CC cockpit case is used for **charging the rechargeable batteries** inside the bodypack transmitters and receivers, as well as **transmitting the pairing information** from the transmitter to the receivers.

This chapter will explain how to operate the cockpit chargers Unite CC-28/2 and Unite CC-36/2.

# CONTROLS AND INDICATORS

## Top View

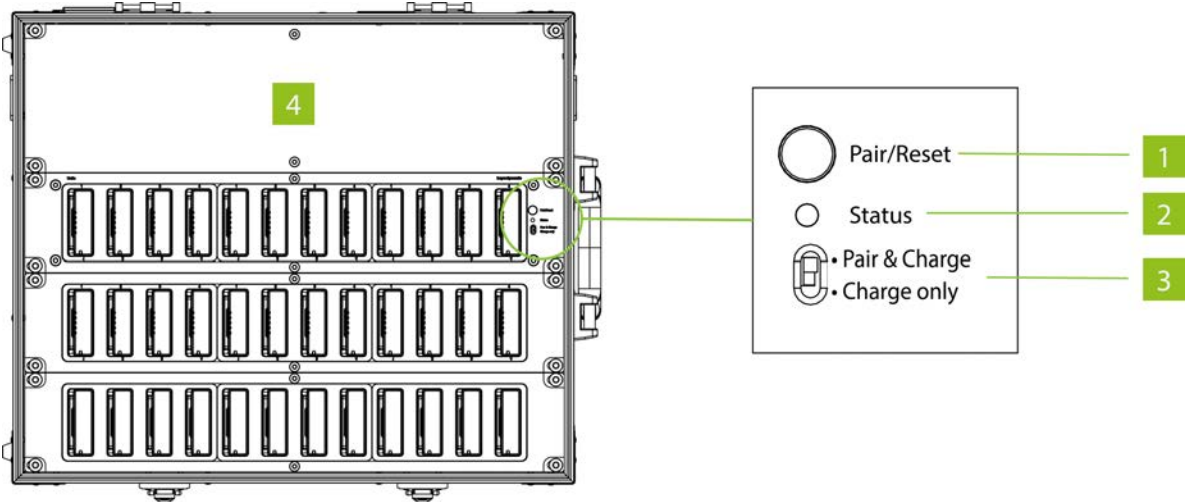

1. Button for initiating the pairing process or clearing stored pairing information in the charger
2. Status indicator light for pairing status
3. Switch for "Pair & Charge" or "Charge only"
4. Charging modules with 4 charging compartments each

Version	Charging slots for pocket devices	Combination charging slots for handheld transmitters or pocket devices
Unite CC-28/2	28	2
Unite CC-36/2	36	2

# Rear View

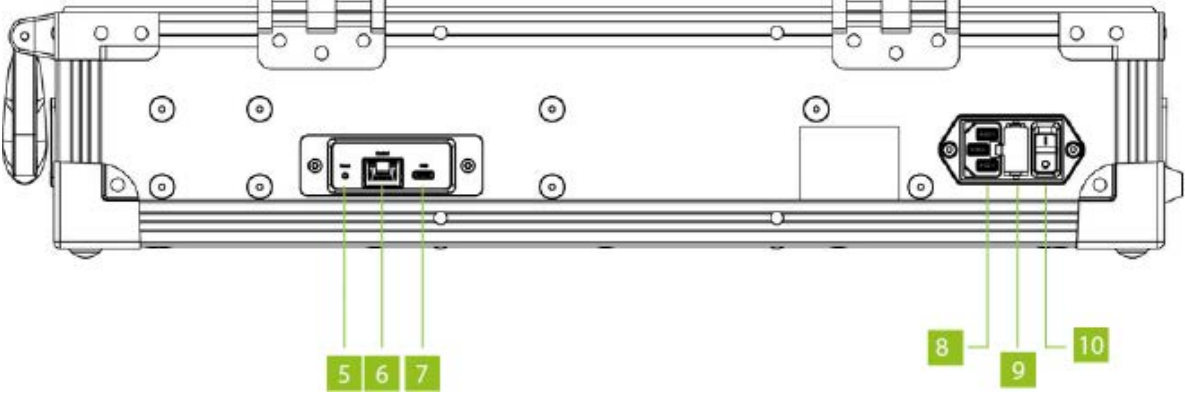

- 5. Reset button
- 6. Ethernet connection
- 7. USB connection
- 8. Mains connection
- 9. Fuse drawer (2 x 3.15 A fuse, time-lag)
- 10. On-off switch

# MAINS CONNECTIONS



When the Cockpit case is in use, do not mount the cover on the case. There is a risk of overheating and fire.

- › Connect the IEC connector of the power cable to the mains connection of the Cockpit case. Connect the power plug to a power outlet.
- › Switch on the Cockpit case via the on-off switch.
- › When not in use, switch off the device and disconnect the power plug from the power socket. Make sure that you do not pull on the cable, but on the power plug.

# ESTABLISHING PAIRING

**Transmitters and receivers must be paired** so that they can communicate with each other. For a successful pairing the channel name, **group ID and audio encryption key are required**. The required audio encryption key is generated in the Unite CC cockpit case or via the Unite Manager software. During the pairing process, it is first stored on the cockpit case and then it is transferred to the transmitter and receiver in the charging compartments.

In this context, please also note the **position of the switch** on the cockpit case. The switch must be set to the "Pair & Charge" position so that the pairing information can be transmitted from the Unite CC to the transmitters and receivers.

There are three different ways to pair the Unite transmitters with receivers:

1. Via an individual charger.
2. Using the Unite Manager Software on a PC.
3. Via dynamic channel search.

## Group ID

The group ID refers to devices that can be combined to a virtual group. For example, all devices of a building, a travel group or a conference room.

## Using with Group ID 150-256

**By default**, the transmitters and receivers are supplied with the group **ID 256**. A common factory-set audio encryption key, which cannot be changed, is used for the group ID range of 150 to 256.

The audio encryption key ensures **additional security** against unauthorised listening during the wireless transmission. Due to the factory-set audio encryption key the devices within the group ID range of 150 to 256 can connect to each other without pairing via the charger. In this case receivers can connect to transmitters via the dynamic channel search.



Example: Via the dynamic channel search, a receiver which is set to the group ID 160 will find all transmitters which are active and also set to the group ID 160. The receiver will not find transmitters beyond the set ID range of 160.



When using **several transmitters** (e.g. Unite AP4 and several Unite TP) with the same group ID at the same time, make sure that the individual channel names differ from each other! Otherwise this can cause connection problems with the receivers!

## Using with Group ID 1-149

If several receivers are to be divided into different groups with an individual encryption, for each group an individual group **ID between 1 and 149** can be assigned. A **separate audio encryption key is generated** for an individual group ID in order to ensure additional security against unauthorized listening during the wireless transmission. This audio encryption key is generated during the pairing process, stored in the charger and transmitted from the charger to the transmitter and receiver, along with the channel name and group ID.

The receivers can only connect to a transmitter with which they have been paired via the charger. If the group ID is subsequently set manually on a receiver which has not been paired, no connection can be established to the transmitter with the encrypted group ID, because the receiver does not have the audio encryption key.

## Changing the Group ID with a Charging Unit

To establish a pairing with a charging unit, please proceed as described below:

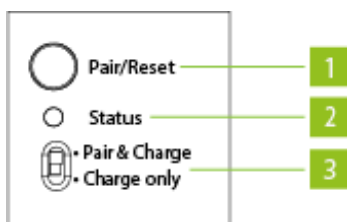

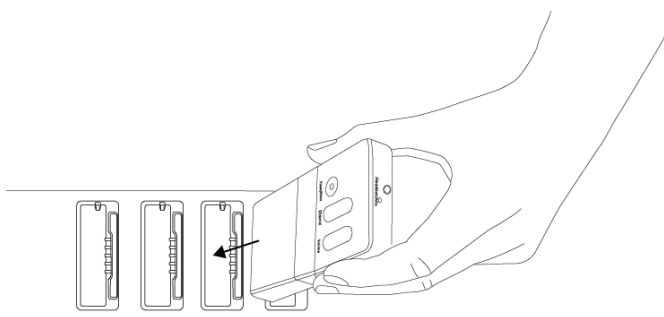

1. On the transmitter, set the group ID you wish to use for pairing.
2. Insert **one transmitter only** in the charger. If more than one transmitter is used in the charger, pairing will not start and the charger's status indicator (2) will show an error message (see table 2). Alternatively you can connect the transmitter using a USB cable connected to the charger's USB port.
3. Insert one or more receivers to be paired with the transmitter into the charger's charging compartment. You can also connect another receiver to the charger using the USB port. Remove all receivers that are not to be paired. Should no receiver be connected to the charger, pairing information is stored in the charger only. This is used for later pairing without connecting the transmitter to the charger.
4. To transmit information from the transmitter to the receivers in the charging compartments and to the charger itself for future pairings, hold down the "Pair/Reset" button (1) on the charger for more than 2 seconds. The "Status" light (2) will flash yellow for a few seconds if the pairing is successful. The status light will then remain yellow because the pairing information is now also saved in the charger.
5. If you wish to pair other receivers, remove the transmitter and all receivers from the charger, switch to "Pair & Charge" (3) and insert the unpaired receivers into the charger. The pairing information will be saved immediately in the unpaired receivers. The status light on the receiver will rapidly flash yellow while this happens.
6. If you have no further devices to pair, switch the charger to "Charge only" (3).

7. Switch on the transmitter and one receiver to check that they have both been paired successfully. After a few seconds the status light on the receiver will light up green and show the channel name of the transmitter.
8. To delete pairing information stored in the charger, hold the "Copy/Reset" button down for more than 5 seconds. The status light (2) will then remain permanently green.
9. In pairing mode (switch to "Pair & Charge"), the status light (2) on the charger will display the following information:

Display	Charging status
Off	The device is switched off
Green	<ul style="list-style-type: none"> <li>• The device is ready to use</li> <li>• No pairing information saved</li> </ul>
Flashing yellow	Pairing information is being copied to the charger or receiver
Yellow	Pairing information has been stored in the charger
Flashing green/yellow rapidly	Device is being localised
Flashes red 5 times	<ul style="list-style-type: none"> <li>• No transmitter</li> <li>• Too many transmitters</li> </ul>
Flashing red rapidly	<ul style="list-style-type: none"> <li>• Operating error</li> <li>• Charging error</li> </ul>

# CHARGING

1. Set the switch to "Charge only" when no automatic pairing function is needed.
2. Insert the bodypack receivers / transmitters into the charging compartments so that the charging contact of the transmitters / receivers have contact with those in the charging module.

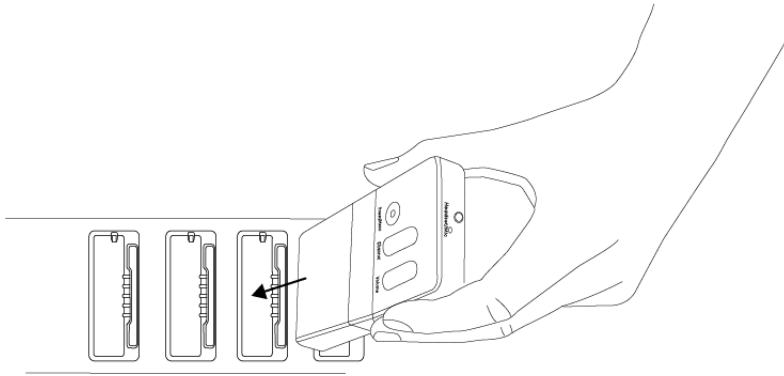

3. The charging will start automatically.
4. The state of charge of the batteries is indicated by the LED of the appropriate device:

Display	Charging status
Off	The device is switched off
Flashing green slowly	Charging mode 0–100%
Green	Battery is charged
Flashing yellow slowly	Pairing information is being copied from the transmitter
Yellow for 10 seconds	Device information successfully copied to charger/devices
Flashing red slowly for 10 seconds	<ul style="list-style-type: none"> <li>• More than one transmitter in the charger at the start of the pairing process</li> <li>• Other pairing errors</li> </ul>
Flashing green/yellow rapidly	Device is being localized
Flashing red rapidly	Charging error

# AUTOMATIC FIRMWARE UPDATE

By using the Unite Cockpit Rack/Case you can upload firmware updates to Unite transmitters/receivers.

With the current factory settings, the Unite Cockpit Rack/Case will **automatically update the firmware of the Unite transmitters/receivers during the first charging process**. Just insert the transmitters/receivers into the charging compartments.

During the firmware update, the status indicator light of the Unite transmitters/receivers will illuminate red. This process will take **approx. 5 minutes**. Should the process take longer than 10 minutes, turn the Unite Cockpit Rack/Case off and on again. The update process will then restart.



Please note that after a successful update to a new firmware version, the Unite transmitters/receivers are no longer compatible with older firmware versions.

# CONDITIONING THE BATTERY

In order to achieve the maximum capacity of the battery, we recommend **discharging the transmitters/receivers completely** to carry out a complete charging cycle afterwards.

This also increases the accuracy of the battery indicator on the display of the Unite transmitters/receivers.

# SERVICE MODE

For maximum operational reliability, the Unite Cockpit Case features a so-called service mode.

If the device is **disconnected** from the mains within **45 seconds** after being switched on (e.g. by accidental switching off), the device will boot in a **safety mode** and check itself.

If this service mode is activated automatically (after booting unsuccessfully), the system will return to its usual operating mode after approx. 3 minutes.

# UNITE CR

The Unite Cockpit Rack can be mounted into a 19" rack. It is used for charging the rechargeable batteries inside the Unite transmitters and receivers as well as transmitting the pairing information from the transmitter to the receivers.

This chapter will explain how to operate the cockpit rack Unite CR-12P.



# CONTROLS AND INDICATORS

## Top View

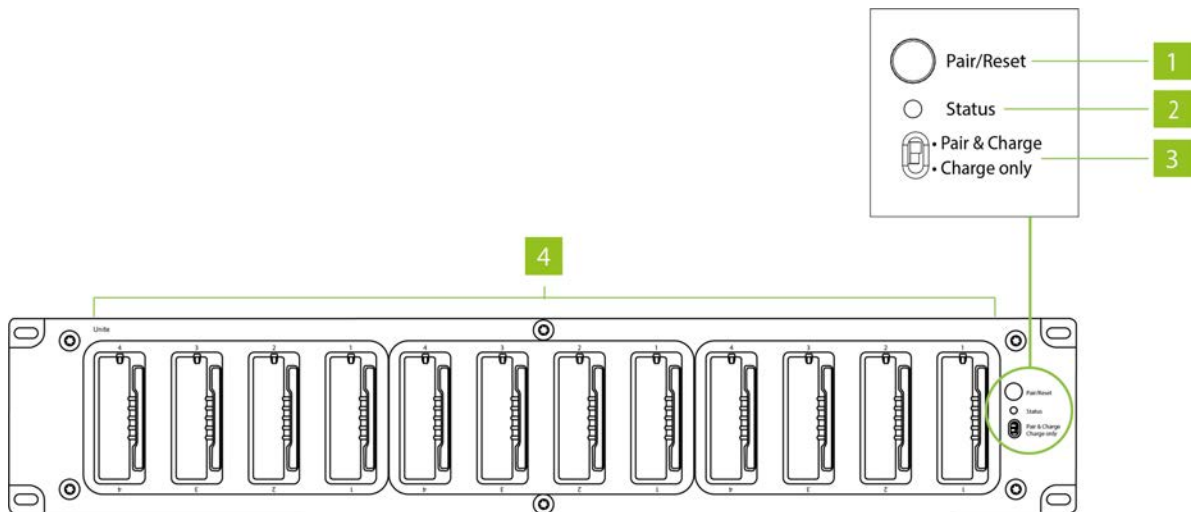

1. Button for initiating the pairing process or clearing stored pairing information in the charger
2. Status indicator light for pairing status
3. Switch for "Pair & Charge" or "Charge only"
4. 3 charging modules with 4 charging compartments each (a maximum of 12 bodypack transmitters and receivers can be charged simultaneously)

# Rear View

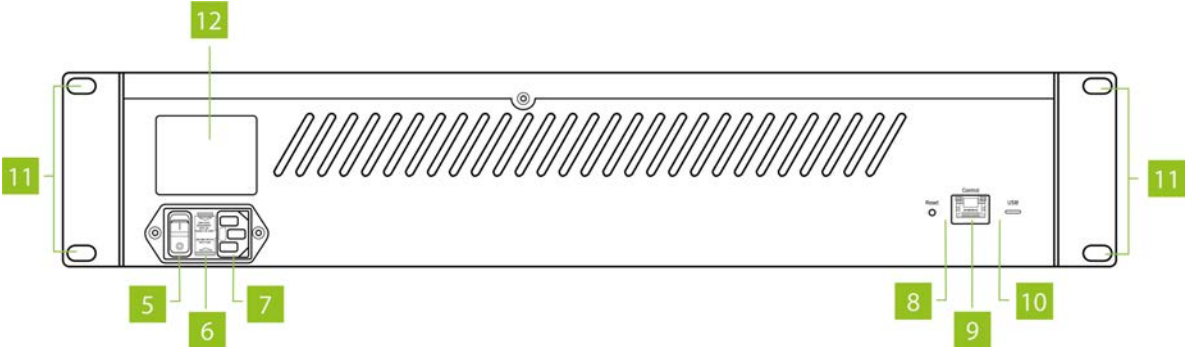

- 5. On-off switch
- 6. Fuse drawer (2 x 3.15 A fuse, time-lag)
- 7. Mains connection
- 8. Reset button
- 9. Ethernet connection
- 10. USB port
- 11. Holes for rack mounting
- 12. Type label

# RACK MOUNTING

The charger is provided with holes (11) on the left and right hand side for 19" rack mounting.

Insert the charger into the 19" rack and tighten it with four screws (not included in the delivery).

## **Warning:**

- › When installing the charger into a 19" rack or with other devices into a rack, the ambient temperature, the mechanical stress and the electrical potentials will be different than for devices that stand separately.
- › If you install more than one charger into a rack, you should make sure that there is an appropriate ventilation (e.g. through ventilation panels), because of the heat between the chargers.
- › The ambient temperature of the rack must not exceed the temperature specified in the technical specifications.
- › Make sure that the rack is not top-heavy with too many devices and will not overturn.
- › When connecting to the power supply read the information on the typeplate (12) . Avoid overloading circuits. If necessary, provide an overcurrent protection.

# MAINS CONNECTIONS

- › Connect the IEC connector of the power cable to the mains connection of the Cockpit case. Connect the power plug to a power outlet.
- › Switch on the Cockpit case via the on-off switch (5) .
- › When not in use, switch off the device and disconnect the power plug from the power socket.
- › If the device is not used for a longer period of time, disconnect the power plug from the power socket. Make sure that you do not pull on the cable, but on the power plug.

# ESTABLISHING PAIRING

**Transmitters and receivers must be paired** so that they can communicate with each other. For a successful pairing the channel name, **group ID and audio encryption key are required**. The required audio encryption key is generated in the Unite CR cockpit rack or via the Unite Manager software. During the pairing process, it is first stored on the cockpit rack and then it is transferred to the transmitter and receiver in the charging compartments.

In this context, please also note the **position of the switch** on the cockpit rack. The switch must be set to the "Pair & Charge" position so that the pairing information can be transmitted from the Unite CR to the transmitters and receivers.

There are three different ways to pair the Unite transmitters with receivers:

1. Via an individual charger.
2. Using the Unite Manager Software on a PC.
3. Via dynamic channel search.

## Group ID

The group ID refers to devices that can be combined to a virtual group. For example, all devices of a building, a travel group or a conference room.

## Using with Group ID 150-256

**By default**, the transmitters and receivers are supplied with the group **ID 256**. A common factory-set audio encryption key, which cannot be changed, is used for the group ID range of 150 to 256.

The audio encryption key ensures **additional security** against unauthorised listening during the wireless transmission. Due to the factory-set audio encryption key the devices within the group ID range of 150 to 256 can connect to each other without pairing via the charger. In this case receivers can connect to transmitters via the dynamic channel search.

Example: Via the dynamic channel search, a receiver which is set to the group ID 160 will find all transmitters which are active and also set to the group ID 160. The receiver will not find transmitters beyond the set ID range of 160.



When using **several transmitters** (e.g. Unite AP4 and several Unite TP) with the same group ID at the same time, make sure that the individual channel names differ from each other! Otherwise this can cause connection problems with the receivers!

## Using with Group ID 1-149

If several receivers are to be divided into different groups with an individual encryption, for each group an individual group **ID between 1 and 149** can be assigned. A **separate audio encryption key is generated** for an individual group ID in order to ensure additional security against unauthorized listening during the wireless transmission. This audio encryption key is generated during the pairing process, stored in the charger and transmitted from the charger to the transmitter and receiver, along with the channel name and group ID.

The receivers can only connect to a transmitter with which they have been paired via the charger. If the group ID is subsequently set manually on a receiver which has not been paired, no connection can be established to the transmitter with the encrypted group ID, because the receiver does not have the audio encryption key.

## Changing the Group ID with a Charging Unit

To establish a pairing with a charging unit, please proceed as described below:

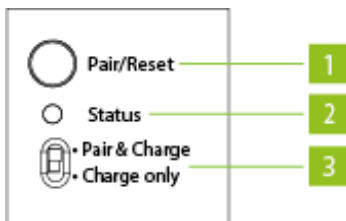

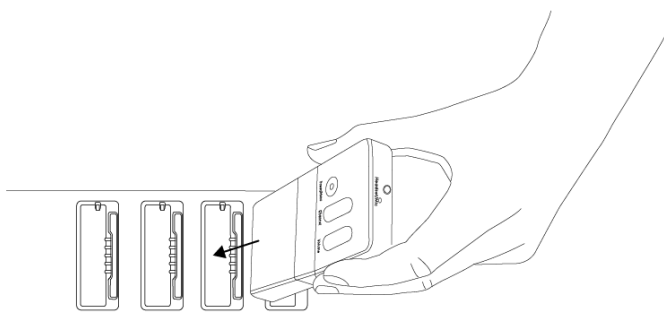

1. On the transmitter, set the group ID you wish to use for pairing.
2. Insert **one transmitter only** in the charger. If more than one transmitter is used in the charger, pairing will not start and the charger's status indicator (2) will show an error message (see table 2). Alternatively you can connect the transmitter using a USB cable connected to the charger's USB port.
3. Insert one or more receivers to be paired with the transmitter into the charger's charging compartment. You can also connect another receiver to the charger using the USB port. Remove all receivers that are not to be paired. Should no receiver be connected to the charger, pairing information is stored in the charger only. This is used for later pairing without connecting the transmitter to the charger.
4. To transmit information from the transmitter to the receivers in the charging compartments and to the charger itself for future pairings, hold down the "Pair/Reset" button (1) on the charger for more than 2 seconds. The "Status" light (2) will flash yellow for a few seconds if the pairing is successful. The status light will then remain yellow because the pairing information is now also saved in the charger.
5. If you wish to pair other receivers, remove the transmitter and all receivers from the charger, switch to "Pair & Charge" (3) and insert the unpaired receivers into the charger. The pairing information will be saved immediately in the unpaired receivers. The status light on the receiver will rapidly flash yellow while this happens.
6. If you have no further devices to pair, switch the charger to "Charge only" (3).

7. Switch on the transmitter and one receiver to check that they have both been paired successfully. After a few seconds the status light on the receiver will light up green and show the channel name of the transmitter.
8. To delete pairing information stored in the charger, hold the "Copy/Reset" button down for more than 5 seconds. The status light (2) will then remain permanently green.
9. In pairing mode (switch to "Pair & Charge"), the status light (2) on the charger will display the following information:

Display	Charging status
Off	The device is switched off
Green	<ul style="list-style-type: none"> <li>• The device is ready to use</li> <li>• No pairing information saved</li> </ul>
Flashing yellow	Pairing information is being copied to the charger or receiver
Yellow	Pairing information has been stored in the charger
Flashing green/yellow rapidly	Device is being localised
Flashes red 5 times	<ul style="list-style-type: none"> <li>• No transmitter</li> <li>• Too many transmitters</li> </ul>
Flashing red rapidly	<ul style="list-style-type: none"> <li>• Operating error</li> <li>• Charging error</li> </ul>



# CHARGING

1. Set the switch to "Charge only" when no automatic pairing function is needed.
2. Insert the bodypack receivers / transmitters into the charging compartments so that the charging contact of the transmitters / receivers have contact with those in the charging module.

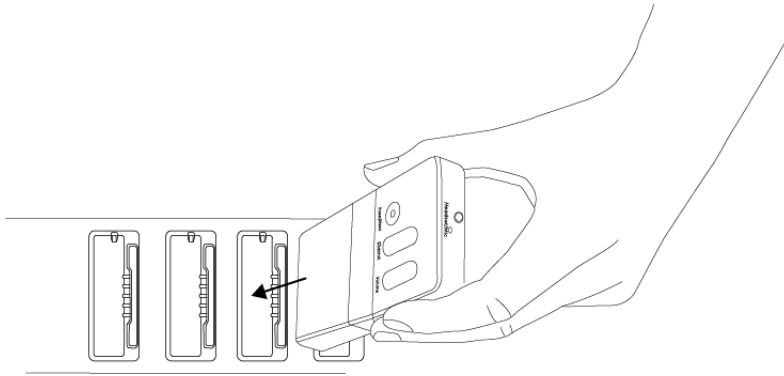

3. The charging will start automatically.
4. The state of charge of the batteries is indicated by the LED of the appropriate device:

Display	Charging status
Off	The device is switched off
Flashing green slowly	Charging mode 0–100%
Green	Battery is charged
Flashing yellow slowly	Pairing information is being copied from the transmitter
Yellow for 10 seconds	Device information successfully copied to charger/devices
Flashing red slowly for 10 seconds	<ul style="list-style-type: none"> <li>• More than one transmitter in the charger at the start of the pairing process</li> <li>• Other pairing errors</li> </ul>
Flashing green/yellow rapidly	Device is being localized
Flashing red rapidly	Charging error

# AUTOMATIC FIRMWARE UPDATE

By using the Unite Cockpit Rack/Case you can upload firmware updates to Unite transmitters/receivers.

With the current factory settings, the Unite Cockpit Rack/Case will **automatically update the firmware of the Unite transmitters/receivers during the first charging process**. Just insert the transmitters/receivers into the charging compartments.

During the firmware update, the status indicator light of the Unite transmitters/receivers will illuminate red. This process will take **approx. 5 minutes**. Should the process take longer than 10 minutes, turn the Unite Cockpit Rack/Case off and on again. The update process will then restart.



Please note that after a successful update to a new firmware version, the Unite transmitters/receivers are no longer compatible with older firmware versions.

# CONDITIONING THE BATTERY

In order to achieve the maximum capacity of the battery, we recommend **discharging the transmitters/receivers completely** to carry out a complete charging cycle afterwards.

This also increases the accuracy of the battery indicator on the display of the Unite transmitters/receivers.

# SERVICE MODE

For maximum operational reliability, the Unite Cockpit Rack features a so-called service mode.

If the device is **disconnected** from the mains within **45 seconds** after being switched on (e.g. by accidental switching off), the device will boot in a **safety mode** and check itself.

If this service mode is activated automatically (after booting unsuccessfully), the system will return to its usual operating mode after approx. 3 minutes.

# UNITE CDD, CDS AND DS

The **Unite CDD-8/4** and **Unite CDS-4/2** cockpit chargers are used to charge the batteries in the Unite transmitters and receivers and to transfer the pairing information from the transmitters to the receivers. The **Unite DS-4/2** desktop charger is only used for charging the batteries in the transmitters and receivers.

This chapter will explain how to operate these devices.

# CONTROLS AND INDICATORS

## Top View

### TOP VIEW OF UNITE CDS-4/2 AND UNITE DS-4/2

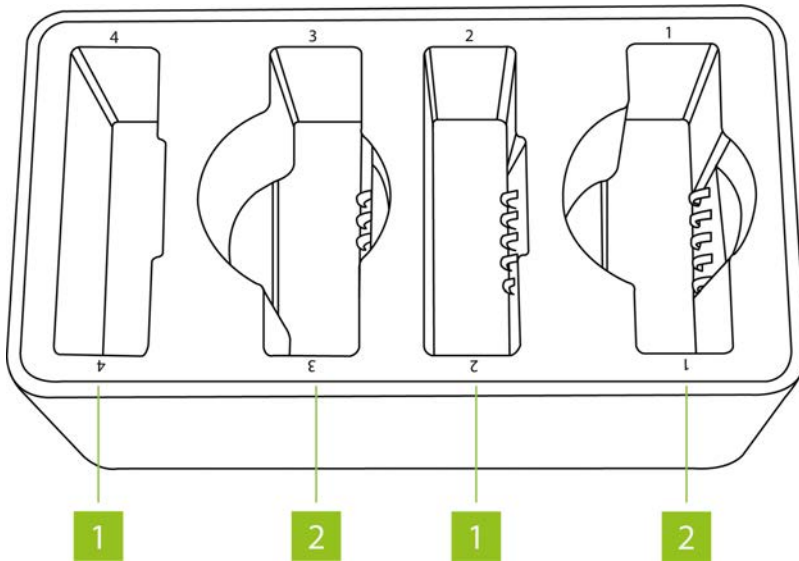

1. Charging compartment for bodypack transmitter or receiver:

The Unite CDS-4/2 and Unite DS-4/2 desktop chargers have 4 charging compartments of which 2 are combined compartments for charging a handheld transmitter or bodypack device.

2. Combined charging compartment for one handheld transmitter or bodypack device

## TOP VIEW OF UNITE CDD-8/4

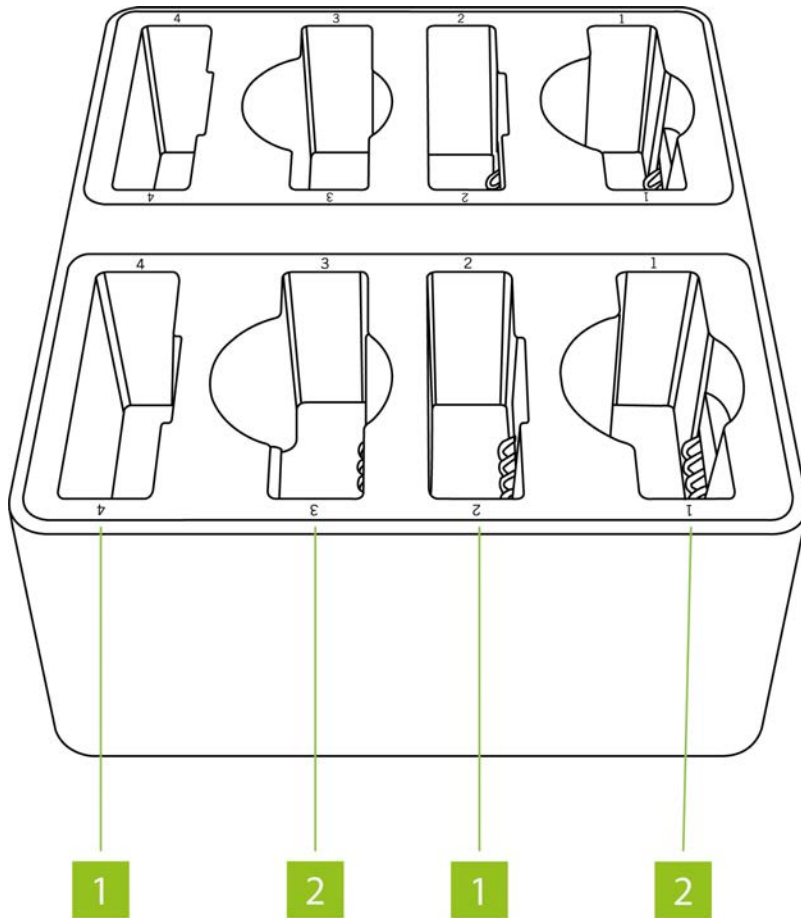

1. Charging compartment for bodypack transmitter or receiver:

The Unite CDD-8/4 desktop charger has 8 charging compartments of which 4 are combined compartments for charging a handheld transmitter or bodypack device

2. Combined charging compartment for one handheld transmitter or bodypack device

## Rear View

### REAR VIEW OF UNITE CDS-4/2 AND UNITE CDD-8/4

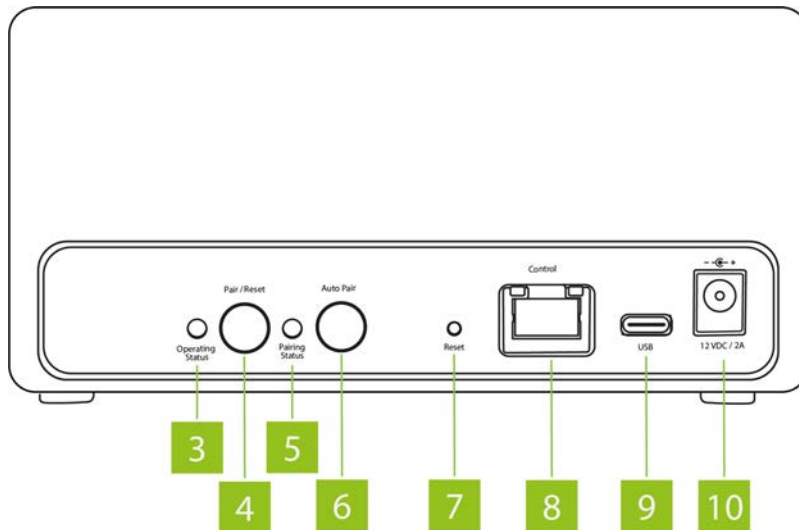

3. Operating control LED
4. Button to start the pairing process or to clear saved pairing information in the charger
5. Status display for pairing status and automatic pairing process
6. Button for automatic pairing process
7. Reset button for restoring the factory IP address setting
8. Ethernet connection
9. USB-C connection
10. 12 V DC connection for power supply unit



CDS-4/2: Please use only the supplied XP Power VET36US120C2-JA power supply unit!

CDD-8/4: Please use only the supplied XP Power VEC50US12 power supply unit!



## REAR VIEW OF UNITE DS-4/2

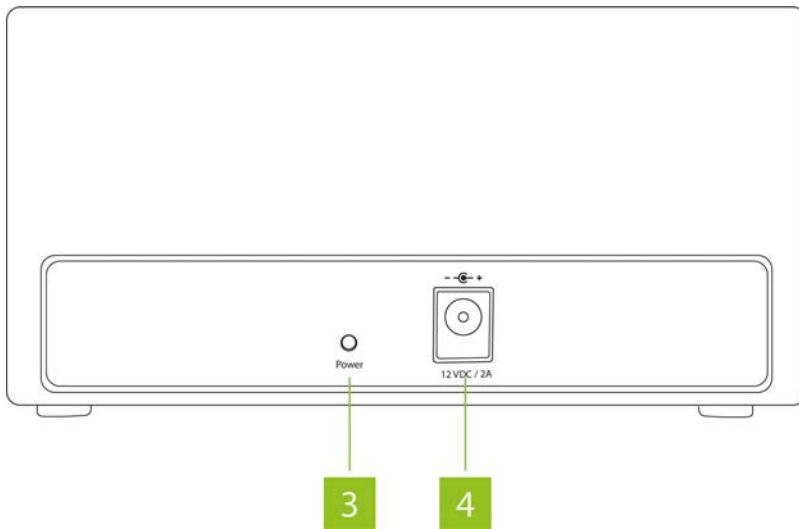

3. "Power" LED
4. 12 V DC connection for power supply unite



DS-4/2: Please use only the supplied XP Power VET36US120C2-JA power supply unit!

# MOUNTING THE CHARGERS ON A TABLE

The Unite CDS-4/2, Unite CDD-8/4 and Unite DS-4/2 desktop chargers have holes on their bottom, which you can use to attach the chargers on a table with screws using a separate drilling template. Use M3 screws for this. The length of the screws depends on the thickness of the desktop.



The screws for mounting must not penetrate the housing **by more than 6 mm!** The height of the rubber pads is approx. 3.4 mm. If necessary, you can remove the rubber pads before attaching. You will find an appropriate drawing in the datasheet on the following Unite page of Televic Knowledge Base:

<https://conference.televic.digital/knowledgebase/products/unite/>

## Bottom of Unite CDD-8/4

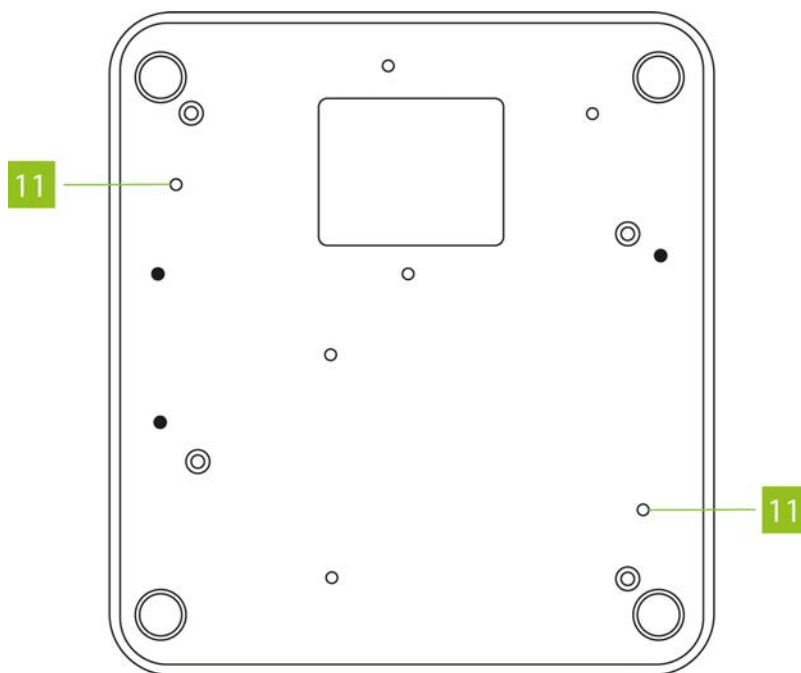

11. Holes for mounting on a desktop with M3 screws

### Bottom of Unite CDS-4/2 and Unite DS-4/2

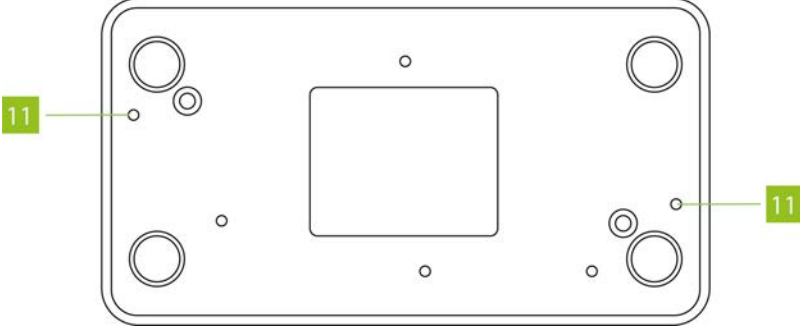

11. Holes for mounting on a desktop with M3 screws

# MAINS CONNECTIONS

- › Connect the AC adapter with the power plug to a power outlet and with the DC plug to a 12 V DC socket (10) of the charger.
- › The charger has no separate on/off switch and is immediately ready for use.
- › When the device is not in use, remove the mains plug from the power outlet. Make sure that you do not pull on the cable, but on the power plug.
- › Make sure that you **connect only the supplied power supply unit** to the Unite CDD-8/4, Unite CDS-4/2 and Unite DS-4/2 charger. The internal pin of the DC socket of the Unite CDD-8/4 has a **different diameter** than the pin of the DC socket of the Unite CDS-4/2.

# ESTABLISHING PAIRING



Pairing is possible with the **Unite CDD-8/4 and Unite CDS-4/2 only**.

**Transmitters and receivers must be paired** so that they can communicate with each other. For a successful pairing the channel name, **group ID and audio encryption key are required**. The required audio encryption key is generated in the Unite CDD-8/4 and Unite CDS-4/2 chargers via the Unite Manager software. During the pairing process, it is first stored on the cockpit case and then it is transferred to the transmitter and receiver in the charging compartments.

In this context, please also note the **position of the switch** on the cockpit rack. The switch must be set to the "Pair & Charge" position so that the pairing information can be transmitted from the Unite CR to the transmitters and receivers.

There are three different ways to pair the Unite transmitters with receivers:

1. Via an individual charger.
2. Using the Unite Manager Software on a PC.
3. Via dynamic channel search.

## Group ID

The group ID refers to devices that can be combined to a virtual group. For example, all devices of a building, a travel group or a conference room.

## Using with Group ID 150-256

**By default**, the transmitters and receivers are supplied with the group **ID 256**. A common factory-set audio encryption key, which cannot be changed, is used for the group ID range of 150 to 256.

The audio encryption key ensures **additional security** against unauthorised listening during the wireless transmission. Due to the factory-set audio encryption key the devices within the group ID range of 150 to 256 can connect to each other without pairing via the charger. In this case receivers can connect to transmitters via the dynamic channel search.

Example: Via the dynamic channel search, a receiver which is set to the group ID 160 will find all transmitters which are active and also set to the group ID 160. The receiver will not find transmitters beyond the set ID range of 160.



When using **several transmitters** (e.g. Unite AP4 and several Unite TP) with the same group ID at the same time, make sure that the individual channel names differ from each other! Otherwise this can cause connection problems with the receivers!

## Using with Group ID 1-149

If several receivers are to be divided into different groups with an individual encryption, for each group an individual group **ID between 1 and 149** can be assigned. A **separate audio encryption key is generated** for an individual group ID in order to ensure additional security against unauthorized listening during the wireless transmission. This audio encryption key is generated during the pairing process, stored in the charger and transmitted from the charger to the transmitter and receiver, along with the channel name and group ID.

The receivers can only connect to a transmitter with which they have been paired via the charger. If the group ID is subsequently set manually on a receiver which has not been paired, no connection can be established to the transmitter with the encrypted group ID, because the receiver does not have the audio encryption key.

## Change the Group ID

In order to **perform a pairing with an individual charger**, proceed as described in the following:

1. Set the desired group ID on the transmitter you want to use for pairing (see the "Pairing" section of "Pairing" or "Pairing" in this manual for more information).

2. Insert **only one transmitter** into the charging compartment of the charger. If multiple transmitters are inserted, the pairing will not start and the status indicator (5) on the charger will display an error (see table below). Further transmitters must be configured as sub-master so that they can be paired with a transmitter configured as a master. Furthermore, you can connect another transmitter / receiver to the USB port (5) on the charger when using a USB cable type C.
3. Insert one or more receivers into the charging compartments of the charger to be paired with the transmitter. You can also connect another receiver to the charger using the USB port (10). Remove all receivers that **should not** be paired. If there is no receiver in the charging compartments, the pairing information is stored in the charger. This is used for later pairing without connecting the transmitter to the charger.
4. In order to transfer the pairing information from the transmitter to the receivers in the slots and to the charger itself for future pairing, press and hold the "Pair/Reset" button (4) on the charger for more than 2 seconds. When the "Pairing Status" indicator (5) flashes yellow, release the button to perform a pairing. Mobile devices that are now being paired indicate this via a status indicator that illuminates yellow. After successful pairing the "Pairing Status" indicator (5) will permanently illuminate green to display that the pairing information is now also stored in the charger.
5. If you want to pair other receivers, remove the transmitter (Master) and all receivers from the charger and press the "Auto Pair" button (6) once. The "Pairing Status" indicator (5) will illuminate yellow. Insert the receivers that are not yet paired into the charger. The pairing information is immediately stored in these receivers. The "Pairing Status" indicator (5) flashes yellow and displays the active pairing process. On the devices that have received the pairing information, the status indicator lights yellow for about 10 seconds. As soon as the "Pairing Status" indicator (5) is permanently lit yellow, the pairing process is complete and you can remove the receivers from the charging compartments.

In order to end the "Auto Pair" function, press the "Auto Pair" button (6) once. The "Pairing Status" indicator (5) will illuminate green to indicate that the pairing information is stored in the charger.

The "Auto Pair" function is not possible, when no pairing information is stored in the charger. In this case the "Pairing Status" indicator (5) flashes red five times.

6. Switch on the transmitter and a receiver to check whether the pairing was successful. When the devices are successfully paired, the status indicator of both devices will illuminate green and the receiver should display the channel name of the transmitter.
7. In order to delete the stored pairing information, press the "Pair/Reset" button (6) until the "Pairing Status" indicator (5) first flashes yellow and then goes out.

The "Operating Status" indicator (3) on the charger shows the following information:

Indicator light	Operating status
Off	The device is switched off
Green	<ul style="list-style-type: none"> <li>• The device is ready to use</li> </ul>
Flashing green/yellow	Pairing information is being copied to the charger or receiver
Flashing green/yellow	Device is being localized
Flashing red rapidly	<ul style="list-style-type: none"> <li>• Operating error</li> <li>• Charging error</li> </ul>
Red	<ul style="list-style-type: none"> <li>• Device reboots</li> <li>• Device is in "Service mode". Refer to chapter 5.7 "Service mode".</li> <li>• Device performs a firmware update</li> </ul>

The "Pairing Status" indicator (5) on the charger shows the following information:

Indicator light	Operating status
Off	No pairing information is stored
Green	The pairing information is stored; the "Auto Pair" function is not active
Flashing yellow	The pairing information is copied to the charger or receiver
Yellow	The pairing information is stored in the charger and the "Auto Pair" function is active



Indicator light	Operating status
Flashes red 5 times	<ul style="list-style-type: none"> <li>• No transmitter</li> <li>• Too many transmitters</li> <li>• The "Auto Pair" button was pressed although no pairing information is stored</li> </ul>
Red	No pairing possible - pairing locked via the Unite Manager PC software

# CHARGING

1. If pairing is not required and you only want to charge the transmitter and receiver, place the transmitters and receivers in the appropriate charging compartments without activating the pairing process via the "Pair/Reset" (4) or "Auto Pair" (6) button.

If the stored pairing information is no longer needed, you can also delete it by pressing the "Pair/Reset" button (4) for more than 5 seconds. When the "Pairing Status" indicator (5) goes off, the pairing information is deleted.

2. Insert the transmitters / receivers into the charging compartments so that the charging contacts of the transmitters / receivers have contact with those in the charging compartments.

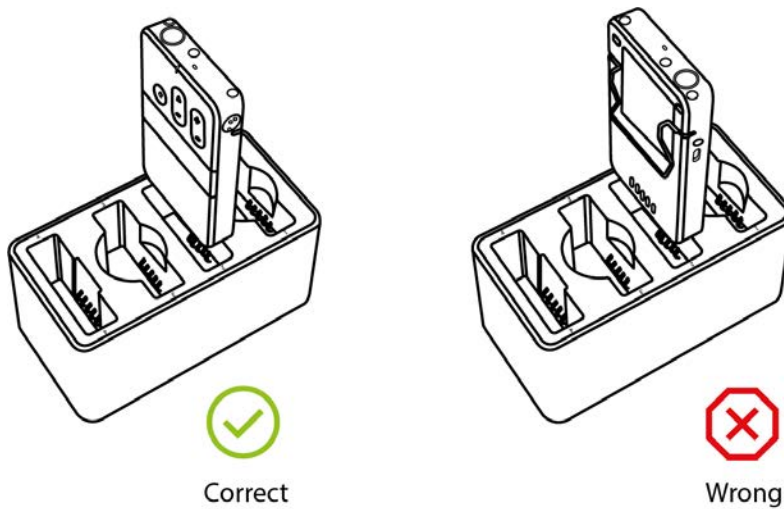

3. Charging will start automatically.
4. The state of charge of the batteries is indicated by the LED of the appropriate transmitter / receiver:

Display	Charging status
Off	The device is switched off
Flashing green slowly	Charging mode 0–100%
Green	Battery is charged
Flashing yellow slowly	Pairing information is being copied from the transmitter
Yellow for 10 seconds	Device information successfully copied to charger/devices

Display	Charging status
Flashing red slowly for 10 seconds	<ul style="list-style-type: none"> <li>• Too many transmitters in the charger when pairing is initiated</li> <li>• Other pairing errors</li> </ul>
Flashing green/yellow rapidly	Device is being localized
Flashing red rapidly	Charging error
Red	Firmware update is performed

# AUTOMATIC FIRMWARE UPDATE



Automatic firmware updates are possible with the **Unite CDD-8/4 and Unite CDS-4/2 only**.

- › By using the Unite Cockpit desktop charger you can upload firmware updates to Unite transmitters / receivers.
- › The Unite Cockpit desktop charger is factory set with the latest firmware for transmitter / receiver at the time of delivery. If you charge transmitters / receivers with older firmware with the charger, the firmware is also automatically updated. This ensures that the charger will work properly with the transmitter / receiver.
- › During the firmware update the status indicator light of the Unite transmitters/receivers will illuminate red. This process will take **approx. 5 minutes**. During the firmware update **do not disconnect the charger from the mains**. Should the process take longer than 10 minutes, turn the Unite Cockpit charger off and on again. The update process will then restart.
- › You can check the update on the transmitter / receiver:

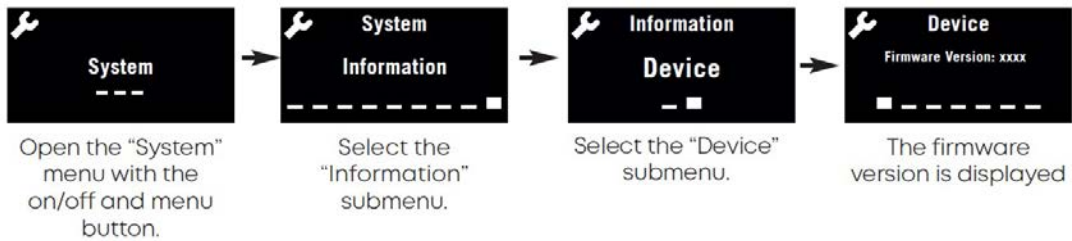

Please note that after a successful update to a new firmware version, the Unite transmitters / receivers are **no longer compatible with older firmware versions**.

# CONDITIONING THE BATTERY

In order to achieve the maximum capacity of the battery, we recommend **discharging the transmitters/receivers completely** to carry out a complete charging cycle afterwards.

This also increases the accuracy of the battery indicator on the display of the Unite transmitters/receivers.

# RESET FACTORY SETTINGS OF THE CHARGER

If you want to restore the factory settings of the charger, press the "Reset" button on the rear of the charger. The charger will restart and restore the factory settings.

A reset restores the following information:

- › DHCP Setting back to "Use DHCP".
- › Static IP address back to default setting 192.168.1.101.
- › Static Subnet mask back to default setting 255.255.255.0.
- › Static Gateway back to default setting 192.168.1.1.
- › Delete/deactivate the individually stored settings of the mobile devices (portable devices, i.e. bodypack, handheld).
- › Deleting the stored pairing information.



Restoring the factory settings does not delete the pre-installed firmware update images!

# SERVICE MODE

For maximum operational safety, the Unite Cockpit charger is equipped with a so-called service mode. This means: If the device is disconnected from the mains within 15 seconds of being switched on (e.g. by accidentally switching it off), the device starts in a service mode and checks itself.

This takes about 1 minute and is indicated by a red operating display (3) on the rear of the charger. The Unite cockpit desktop charger then returns to the normal operating mode. This is indicated by a green operating display.

# UNITE TP

The **Unite TP bodypack transmitter** is used for **speech applications** - e.g. guided tours, multilingual interpretation, intercom and assistive listening. It can also be used as a wireless microphone system, and up to two other Unite transmitters can speak together.

This chapter will explain how to operate the Unite TP bodypack transmitter.



# DESCRIPTION

## Device

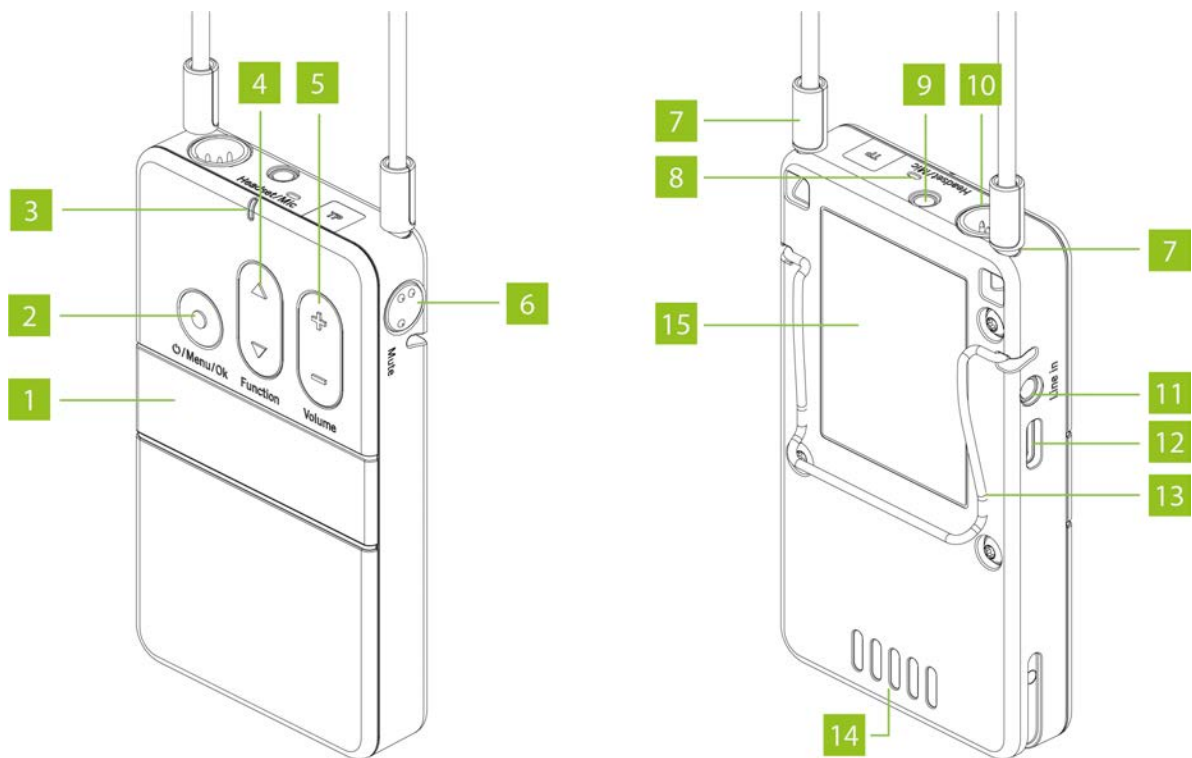

1. **Display:** The display indicates the channel name, battery status and different menus. Refer to the Display section below for more information.
2. **On/Off and menu button :** Use the on/off button to turn the transmitter on or off. To switch off the device, hold down the button for 5 seconds. In order to activate the main menu, hold down the button for 2 seconds. Use the menu button to confirm settings.
3. **Status indicator light:** Refer to the Status Indicator section below for more information.

4. **Multifunction button:** This button is assigned with several functions. These include the shortcuts of the talkback functions. You will find a detailed description of the shortcuts in the chapter about the Talkback Function of the comprehensive system manual. If you are in a menu, you can scroll through the menu to make various settings.
5. **Volume button:** Use this button to adjust the volume of any connected headphones/headsets/induction loops. With "+" the volume is increased, with "-" the volume is reduced.
6. **Mute button:** Use this button to enable or mute the internal or externally connected microphone.
7. **Neck strap attachment:** Attach the supplied neck strap by pushing the pins at the end of the neck strap into the fastening holes. For safety reasons, the fastening will detach when pulled strongly.
8. **Integrated microphone:** The integrated microphone has been specially designed for the talkback function in conjunction with the Unite RP-T bodypack receiver for short queries. For a best possible audio transmission we recommend using an external microphone or headset. If no external microphone or headset is connected, you can speak directly into the integrated microphone. Maintain a distance of 10 cm from the microphone when speaking.
9. **Headphones/headset/induction loop connector:** You can connect headphones, a headset or an induction loop to the jack connection.
10. **Microphone connector:** You can connect a microphone with a 4-pin mini XLR connector to the microphone connector (for pin assignment, please refer to the datasheet).
11. **Line-In, 3-pin jack connector 3.5 mm:** You can connect an external player to the jack connector.
12. **USB port, Type C:** You can use this connector to charge the integrated battery pack via a USB power adapter. Furthermore, you can connect the bodypack transmitter to the USB Type C port on a Unite charger to charge it or to pair it with other devices.
13. **Belt clip:** The belt clip allows you to attach the device to clothing such as a waistband or belt.

14. **Charging contacts:** The built-in battery is charged via the charging contacts when the device is inserted into the charger. Make sure to insert the device fully into the charging slot so that the charging contacts have proper contact.
15. **Type label:** The type label provides information about the name, article number, certification numbers, hardware version, serial number and production date.

## Status Indicator

### During Operation:

Indicator light	Operating status
Off	Device is switched off
Flashing yellow slowly	<ul style="list-style-type: none"> <li>• Ready to operate and battery status &gt; 10%</li> <li>• Out of range (in sub-master mode only)</li> </ul>
Yellow	Connection established and battery status > 10 %
Green	Connection established, audio transmission running (microphone open or another audio source is used) and battery status > 10%
Flashing green slowly	Microphone is muted
Flashing red slowly	Low battery level < 10%
Red	<ul style="list-style-type: none"> <li>• Device is starting</li> <li>• Firmware update is running</li> </ul>
Flashing red rapidly	Critical error

## In The Charger:

Indicator light	Operating status
Off	Device is switched off
Flashing green slowly	Charging 0 - 100%
Green	Battery is charged
Flashing yellow slowly	Pairing information is being copied from the transmitter
Yellow for 10 seconds	Device information is copied successfully to charger/devices
Flashes red slowly for 10 seconds	<ul style="list-style-type: none"> <li>• Too many transmitters in the charger when pairing is initiated</li> <li>• Other pairing error</li> </ul>
Flashing green/yellow rapidly	Device is being localised
Flashing red rapidly	Charging error

## Display

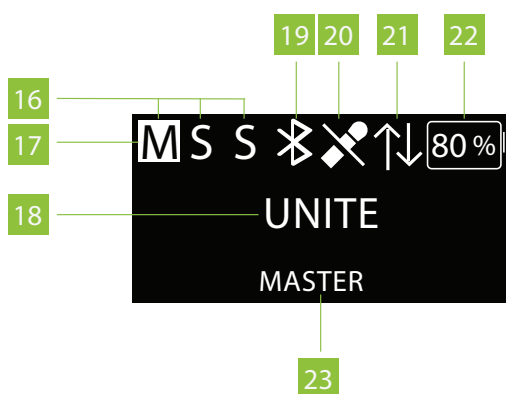

16. **All active speakers:**

M = "Master"

S = 1st "Sub-Master" or 1st speaker (Unite RP-T)

S = 2nd "Sub-Master" or 2nd speaker (Unite RP-T)

17. The highlighted display shows if the **"Master", 1<sup>st</sup> "Sub-Master" or 2<sup>nd</sup> "Sub-Master" is active**

18. **Current channel name**

19. **Bluetooth® status** (various symbols; depending on the status):



Bluetooth activated



Bluetooth connected

20. **Selected microphone source:**



Microphone muted via mute button (6) on the device



Internal microphone activated



Headset activated



XLR connection activated



Auto Mic activated: The device automatically recognises which microphone source is used.

When the headset socket is used, a query is ensued if a headset or headphone is used.

21. **Active, bidirectional talkback connection** (Full-Duplex connection) between:

⌘ "Master" and a Unite RP-T receiver

⌘ "Master" and a "Sub-Master"

The  symbol is only displayed on the connected devices during an active talkback connection.

The other devices of a group display a highlighted "S" during an active talkback connection between two devices.

22. **Remaining battery capacity**

23. **Device configuration** (e.g. Master; Submaster)



For more details about the menu, please read the [Menu Items](#) section of this manual.

# HOW TO WEAR THE BODYPACK TRANSMITTER

There are two options for wearing the bodypack device:

## Neck Strap

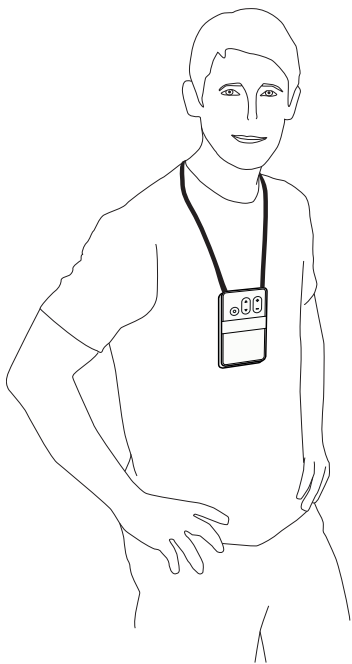

When using the supplied strap, you can wear the bodypack device around the neck. For safety reasons, the fastening will release when pulled strongly.

- › Put the pins at the end of the strap into the fastening holes.
- › Put the strap around the neck.

## Belt Clip



When using the belt clip, you can attach the bodypack device to clothing such as a trouser or skirt waistband.



# CONNECTIONS

## Connecting Headphones / Headset / Induction Loop

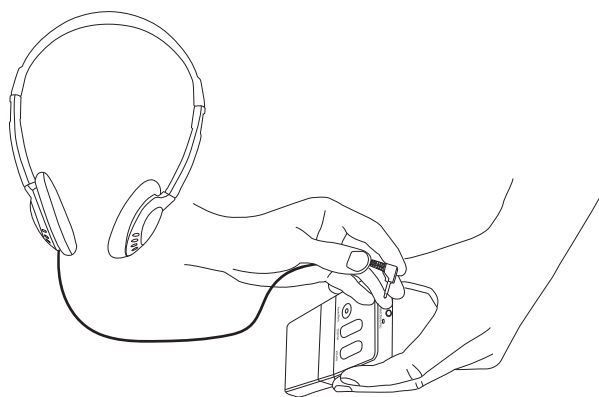

- > You can connect headphones, a headset or an induction loop to the mini jack socket (9) .
- > You can control the volume of the connected device with the volume button (5).



Please note the safety instructions regarding too high volume.

## Connecting a Microphone

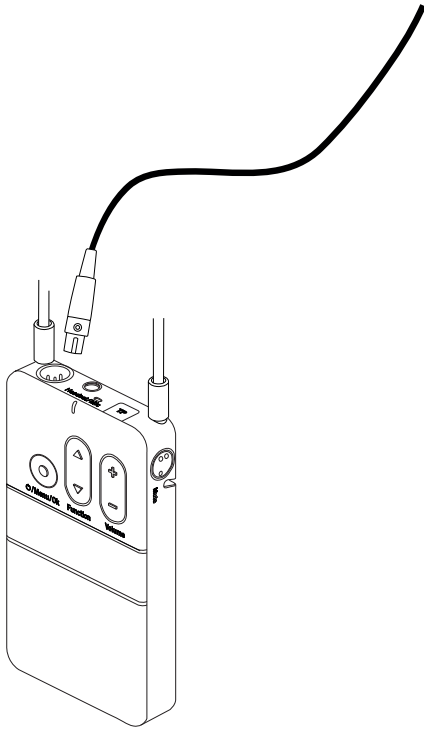

- › You can connect a microphone with a 4-pin mini XLR connector to the microphone connector (10). For pin assignment, please refer to the datasheet.
- › The integrated microphone (8) will be activated if the "internal" mode has been selected as an audio source in the menu or if the "auto" mode has been selected when there is no external microphone connected.



The integrated microphone was specially developed for the talkback function in conjunction with the Unite RP-T bodypack receiver for short queries. For best audio transmission we recommend using an external microphone or headset.

- › Depending on the microphone, you can adjust the sensitivity of the microphone in the "Audio" main menu under "Volume" in the menu items "Mini XLR Mic", "Headset Mic" or "Internal Mic". Refer also to the chapter about the "Menu".
- › With quiet speakers, increase the level. With loud speakers, reduce the level.

## Connecting an External Audio Source

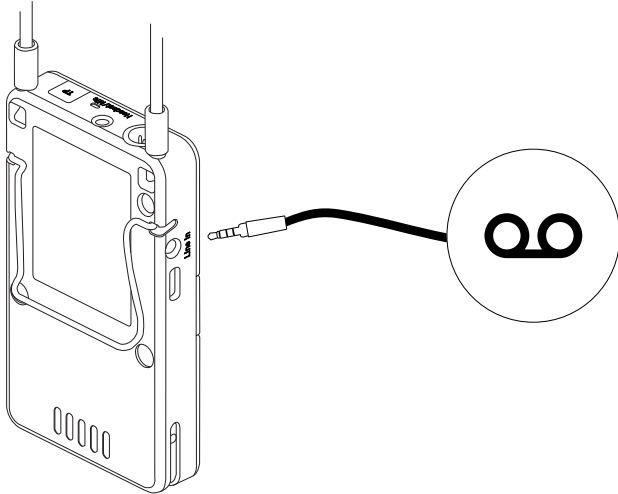

- > If required, you can connect an external audio source with a 3-pole mini jack plug (3.5 mm) to the line-in input (10).
- > You can set the sensitivity of the external audio source in the "Audio" main menu under "Volume" via the "Line in" menu item.
- > Increase the level for quiet audio sources; reduce level for loud audio sources.

# OPERATION

## General Operation Process



Before using the bodypack transmitter for the first time, you must charge the built-in battery. Please use an appropriate Unite charger.

1. Connect a headphone or induction loop to jack socket (9) (see the Connections section).
2. Connect a microphone to the 4-pin mini XLR connector or use a headset with the connector (9).
3. Hold down the on/off button (2) to switch on the transmitter (see the " " below for more information).

The integrated microphone (8) will be activated if the "internal" mode or the "auto" mode, without an external microphone being connected, has been selected as an audio source in the menu.

In order to establish an audio connection between a transmitter and one or more receivers, **all devices must be paired together**. See the "Pairing" section for more information.

All devices are supplied with the group ID 256 and fixed audio encryption allowing quick and easy initial use.

The transmitter will only transmit the audio signal on a channel with a predefined channel name. If there are several transmitters in a group, the channel for the respective transmitter can be selected on the receiver (see the "Set the Channel Name" paragraph in the "Pairing" section for more information).

If you require several device groups or an audio transmission even more secure against eavesdropping, to avoid listening by other groups using Unite devices, follow the steps in the "Creating A New Pairing On The Transmitters" or "Creating A New Pairing With The Charger" to create a new pairing.

## Switching On or Off

- To switch on the bodypack transmitter, briefly press the **⏻/Menu/Ok** button (2).
- In order to switch off the bodypack transmitter, press the button (2) for approx. 5 seconds.
- When the device is switched on, the status indicator displays the operating status information (see table below).

Indicator light	Operating status
Off	Device is switched off
Flashing yellow slowly	<ul style="list-style-type: none"> <li>• Ready to operate and battery status &gt; 10%</li> <li>• Out of range (in slave mode only)</li> </ul>
Yellow	Connection established and battery status > 10 %
Green	Connection established, audio transmission running (microphone open or another audio source is used) and battery status > 10%
Flashing green slowly	Microphone is muted
Flashing red slowly	Low battery level < 10%
Red	<ul style="list-style-type: none"> <li>• Device is starting</li> <li>• Firmware update is running</li> </ul>
Flashing red rapidly	Critical error

- When the Unite TP bodypack transmitter is switched on, the main screen below will be displayed indicating that the transmitter is ready for operation.

> The individual symbols mean:

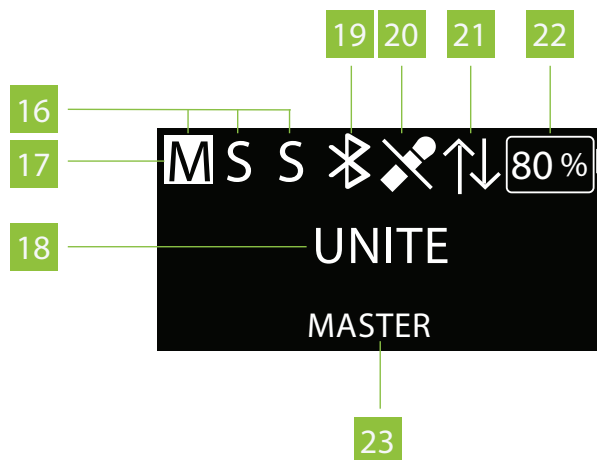

16 Display of all active speakers (Master, 1<sup>st</sup> submaster, 2<sup>nd</sup> submaster)

17 Highlighted display of current type of speaker (Master, 1<sup>st</sup> submaster or 2<sup>nd</sup> submaster)

18 Current channel name

19 Bluetooth® status (various symbols; depending on the status)

20 Headset connected

21 Microphone muted

22 Display of remaining battery capacity

23 Display of the actual speaker



For more details about the menu, please read the [Menu Items](#) section of this manual.

## Adjusting the Volume

Use the volume button (5) to adjust the volume of connected headphone, headset or induction loop.

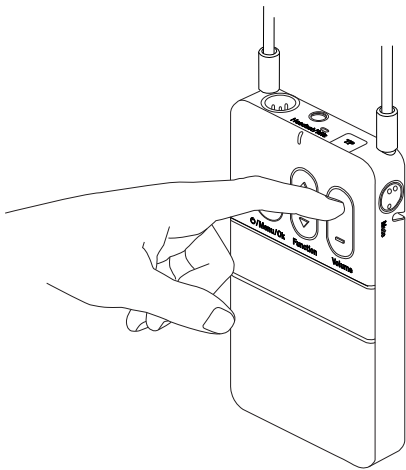

- > Press "+" to increase the volume.
- > Press "-" to reduce the volume.



Please note the safety instructions regarding too high volume.

## Mute Function

Use the mute button (6) to mute the internal or externally connected microphone.

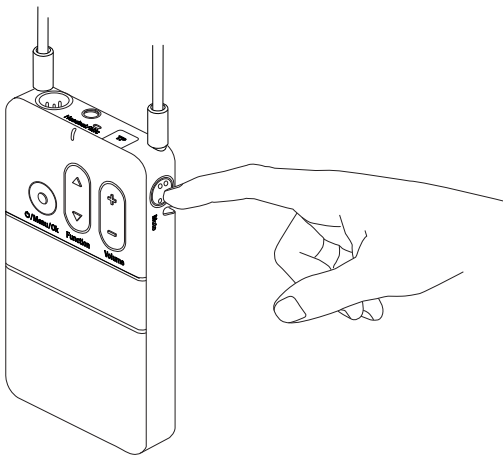

- > If the "Push" setting is selected in the "Audio / Mute Button" menu, hold the mute button down as long as you want to mute the microphone. See also the separate chapter on "Menu items".

- If the "Toggle" setting is selected in the "Audio / Mute Button" menu, you will mute the connected or integrated microphone with the first press of the button. With the second press of the button, you will reactivate the microphone.
- Please keep a distance of approx. 10 cm to the integrated microphone when speaking.



# BLUETOOTH® INTERFACE

The Bluetooth® function of the transmitter is used as an audio interface for the following applications.

- › **For Bluetooth® headphones (Use of the Talkback functionality):** You can connect a headphone via Bluetooth®. This allows listening to the talkback signals of the Unite RP-T receiver and Sub-Master devices.
- › **For playback::** You can also use the Bluetooth® function to playback audio signals from external sources (e.g. smartphones or computers).



If the Bluetooth® is used for the playback of external audio sources, we recommend using the DSP effect **Ducker**. The **Ducker** decreases the signal of an external audio source as soon as someone is speaking into the microphone capsule ensuring optimal speech intelligibility.



For more information, please refer to the "External Interfaces" section in this manual.

# PAIRING

## Creating a Pairing

In order to communicate with each other, the **transmitter and receivers must have the same group ID, encryption key and channel name**. Only then they can communicate with each other. There will be no communication with receivers that do not have the same pairing information. This is illustrated in the figure below:

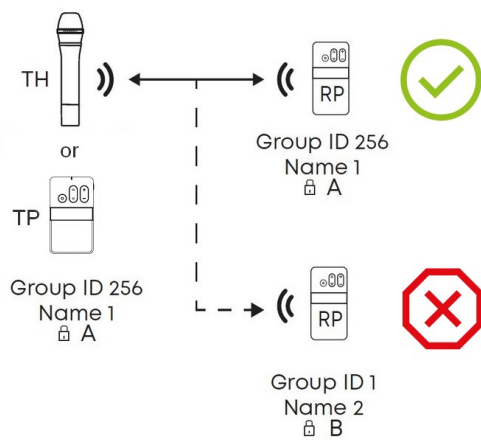

The required audio encryption key is generated in the Unite Charger (Unite CC, CR, CDD-8/4 or CDS-4/2) or via the Unite Manager software. During the pairing process, it is first stored on the charger, and then it is transferred to the transmitter and receiver in the charging compartments.

In this context, please also note the **position of the switch** on the charger. The switch must be set to the "*Pair & Charge*" position so that the pairing information can be transmitted from the Unite charger to the transmitters and receivers.

There are three different ways to pair Unite transmitters with receivers:

1. Via an individual charger.



Pairing is possible with the **Unite CC, CR, CDD-8/4** and **CDS-4/2 only**.

2. Using the Unite Manager Software on a PC.
3. Via dynamic channel search.

## Encryption

The audio data is always encrypted with an AES-256 code to ensure a secure transmission against unauthorized listening.



The required key will be generated within the charging unit itself and transmitted to the transmitters and receivers during the pairing process.

As the encryption code is not transmitted wirelessly, the system is better protected against unauthorized listening. Should the receiver receive a differently encrypted audio signal for which no encryption code has been saved, the received audio signal will be muted. The receiver display will also alternate between showing the relevant channel name and the "KEY!" error message.

The encryption of the audio signal is explained schematically in the "Encryption" diagram below.

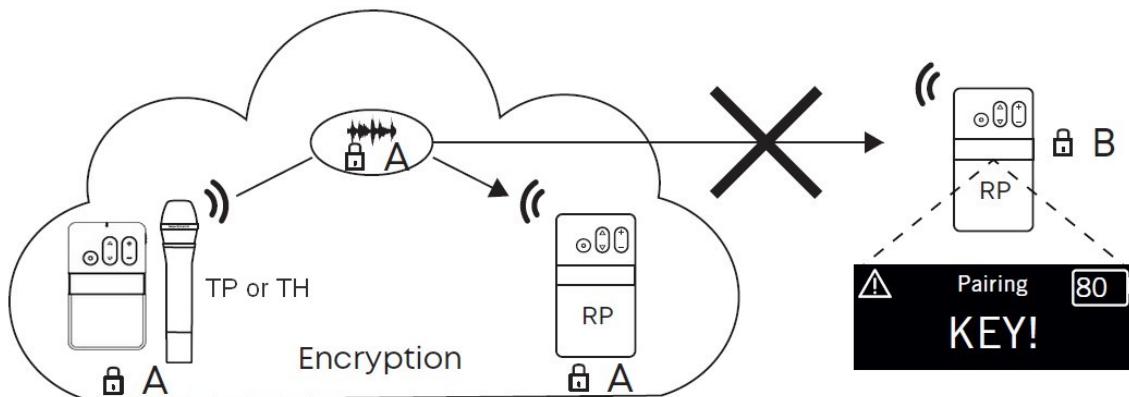

The group IDs in the range of 150 to 256 uses a factory-defined key that cannot be changed. You can use this group ID for a system without pairing.



The transmitter and receiver can only communicate if the settings for group ID, channel name and encryption match. Transmitters cannot communicate with receivers that do not have the same pairing information.



If you need a specific encryption key, you need to use a group ID between the range of 1 and 149. Refer to the **Pairing** section of your device to change the group ID.

## Group ID

The group ID refers to devices that can be combined to a virtual group. For example, all devices of a building, a travel group or a conference room.

## Using with Group ID 150-256

**By default**, the transmitters and receivers are supplied with the group **ID 256**. A common factory-set audio encryption key, which cannot be changed, is used for the group ID range of 150 to 256.

The audio encryption key ensures **additional security** against unauthorised listening during the wireless transmission. Due to the factory-set audio encryption key the devices within the group ID range of 150 to 256 can connect to each other without pairing via the charger. In this case receivers can connect to transmitters via the dynamic channel search.

Example: Via the dynamic channel search, a receiver which is set to the group ID 160 will find all transmitters which are active and also set to the group ID 160. The receiver will not find transmitters beyond the set ID range of 160.



When using **several transmitters** (e.g. Unite AP4 and several Unite TP) with the same group ID at the same time, make sure that the individual channel names differ from each other! Otherwise this can cause connection problems with the receivers!

## Using with Group ID 1-149

If several receivers are to be divided into different groups with an individual encryption, for each group an individual group **ID between 1 and 149** can be assigned. A **separate audio encryption key is generated** for an individual group ID in order to ensure additional security against unauthorized listening during the wireless transmission. This audio encryption key is generated during the pairing process, stored in the charger and transmitted from the charger to the transmitter and receiver, along with the channel name and group ID.

The receivers can only connect to a transmitter with which they have been paired via the charger. If the group ID is subsequently set manually on a receiver which has not been paired, no connection can be established to the transmitter with the encrypted group ID, because the receiver does not have the audio encryption key.

## Changing the Group ID

1. Press and hold the menu button for 2 seconds to activate the main menu.
2. Use the multifunction button to select "System" from the menu.
3. Press the menu button to open the required submenu.
4. Use the multifunction button to select the "Group ID" submenu.
5. Press the menu button to set an group ID.
6. Use the multifunction button to select the desired group ID.

7. Press the menu button to confirm the selected group ID.



Make sure to select the same group ID for all devices of a desired group. Only devices that have the same group ID can communicate with each other. Transmitters with other group IDs are hidden. See the following diagram.

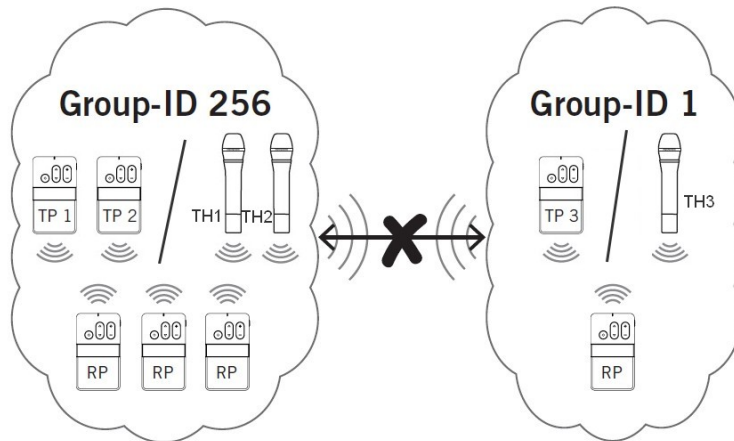

## Setting the Channel Name

Devices that are grouped with one group ID can transmit multiple audio channels via the same group ID.

In order to differentiate between audio channels from several transmitters on the receiver, enter a five-digit name for the channel on the transmitter. Proceed as described in the following:

1. Hold down the menu button on the transmitter for more than 2 seconds to activate the main menu.
2. Use the multifunction button to select "System" from the menu.
3. Press the menu button to open the required sub-menu.
4. Use the multifunction button to select the "Channel Name" sub-menu.
5. Press the menu button to set the channel name.

6. Use the multifunction button to scroll through the characters. When the desired character appears, confirm using the menu button. You can input max. five characters.

As soon as you select the configured transmitter on the receiver, the defined name will be displayed on the receiver's display.

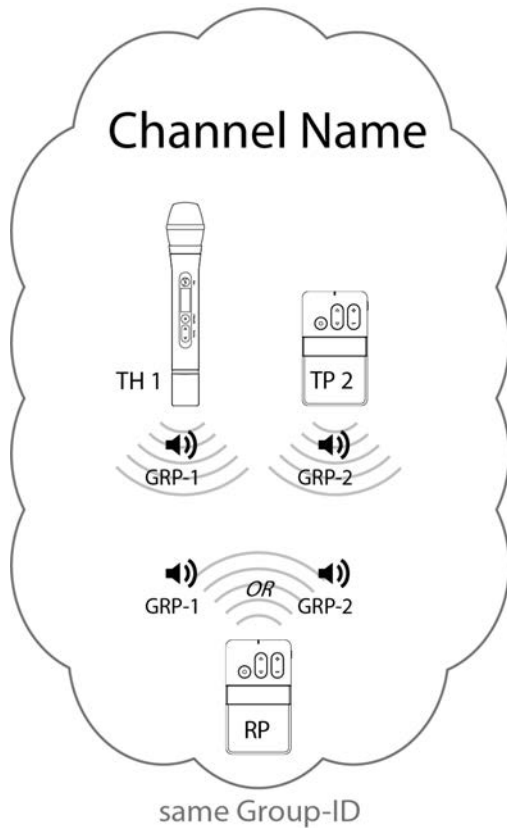



Figure 1-2 Example of two transmitters with different channel names and a receiver that can find and switch between both transmitters.

7. Change the channel on the receiver via the dynamic channel search. Press the  or  symbol of the channel buttons and confirm the displayed "Scan for channels?" question with "Yes" by pressing the menu button. Depending on the DECT environment and the distance to the transmitter, it may take several seconds to find the channels.

8. Press the ▲ or ▼ symbol of the channel buttons to select the transmitter (channel name). In order to confirm press the On/Off and menu button.



Once the channel search is started, the receiver will lose its connection to the previous transmitter.



# USING AS A SUB-MASTER

The Unite transmitter can be configured in a virtual device mode (Sub-Master). This allows up to two additional speakers to be integrated into a device group.

In the Sub-Master mode, the transmitter can set up an exclusive connection to a Master device. In one group, a **maximum of two Sub-Masters** can be active and connected to one Master device.

The connection between a Sub-Master and a Master device is technically the same as the connection between a Unite RP-T with activated "Talkback" function and a "Master". The difference is that the connection between a Unite RP-T and a Master is temporary, while the connection between a Sub-Master and a Master is permanent. In this case the audio channel is permanently open, but it can be muted by pressing the "Mute" button on the Sub-Master.

In addition, there are of course still possibilities to connect external audio sources to the Sub-Master. All audio signals of the Sub-Master are distributed via the Master (Broadcast) and can be routed to the Master. These options can be found in the Master menu at "Talkback" --> "Audio Routing".

## **Examples of up to 3 open microphones in the following device combinations:**

- > 1 x Master + 2 x Sub-Master
- > 1 x Master + 2 x RP-T (Talkback )
- > 1 x Master + 1 x Sub-Master + 1 x RP-T (Talkback)

## Configuring a Sub-Master

In order to configure the Unite transmitter as a Sub-Master, proceed as described below:



1. Use the On/Off and menu button to access the menu "System" --> "Device Mode".
2. Select the Sub-Master option.
3. Confirm the selected option with the On/Off and menu button.
4. Restart the transmitter by pressing the On/Off and menu button.
5. The transmitter reconfigures itself. This can take 1 - 2 minutes.
6. You can reconfigure the device as "Master" at any time.



**Unite TH only:** When you configure a transmitter as a Sub-Master, a **factory setting for the Sub-Master** will be **automatically activated**. This sets the value for the ALC function to "Far" and for the Noise Canceller function to "Low". This is also the factory setting for the configuration as Master.

## Connecting a Sub-Master to a Master

In order to connect a Sub-Master to a Master, you have to perform a channel search. Please proceed as described below:

1. Press the  or  symbol of the multifunction button (5) and start the dynamic channel search.
2. The basic conditions to establish a connection must be guaranteed. Refer to the "Pairing" section of your device in this manual for more information.

Alternatively, you can transmit the pairing information via a charger. As a Sub-Master, the transmitter will receive the channel name, group ID and audio encryption key from the charger like a Unite RP or RP-T.

# USING WITH A UNITE AP4 ACCESS POINT

In conjunction with a Unite AP4 access point, the Unite transmitter can be used as a wireless microphone. In order to establish a connection to a Unite AP4, the transmitter must be configured as "AP4 Mic (Sub-Master)" via the menu.

This mode is technically equivalent to a Sub-Master, which can establish an exclusive connection to the Unite AP4 as the Master.

## Configuring As AP4 Mic (Sub-Master)



1. In order to configure the Unite transmitter in the Sub-Master mode, select in the menu "System" > "Device Mode" > "AP4 Mic (Sub-Master)".
2. Confirm the selected option with the On/Off and menu button.
3. Restart the transmitter by pressing the On/Off and menu button.

The transmitter reconfigures itself. This can take 1 - 2 minutes.

4. You can reconfigure the device as Master at any time.

## Connecting to a Unite AP4 Master

In order to use the Unite transmitter as a wireless microphone with a Unite AP4, you must perform a channel search.

Press the  or  symbol of the multifunction button (4) on the transmitter to start the dynamic channel search. The basic conditions to establish a connection must be guaranteed (refer to the "Pairing" section of your device for more information).

The second way to establish a connection between the Unite transmitter and Unite AP4 is to use the Unite Manager PC software for pairing. Please refer to the [Unite Manager PC software manual](#).

# UNITE TH

The **Unite TH handheld transmitter** is used for **speech applications** - e.g. guided tours, multilingual interpretation, intercom and assistive listening. It can also be used as a wireless microphone system, and up to two other Unite transmitters (Unite TP or Unite TH) can speak together.

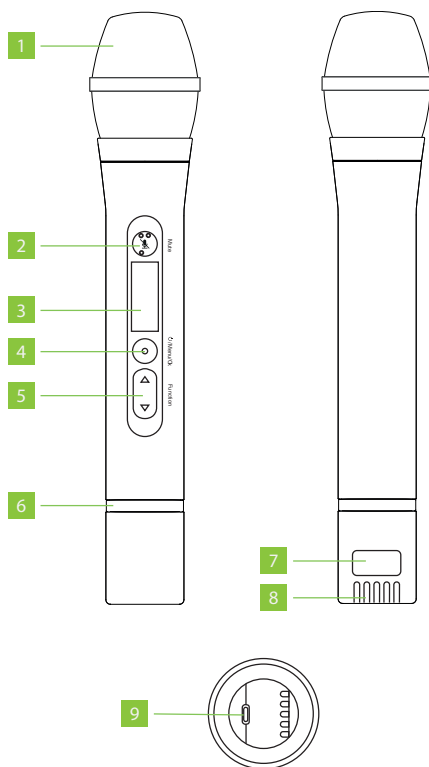

# DESCRIPTION

## Device



1. **Microphone grille** , detachable
2. **Mute button** with status indicator light and braille inscription. With this button you can mute or activate the microphone.
3. **Display**: The display indicates the channel name, battery status and different menus.
4. **On/Off and menu button**: Use the on/off button to turn the transmitter on or off. To switch off the device, hold down the button for 5 seconds. In order to activate the main menu, hold down the button for 2 seconds. Use the menu button to confirm the settings.
5. **Multifunction button**: If you are in a menu, you can scroll through the menu to make various settings. The following functions are available as shortcuts by using the multifunction button:



Talkback function on / off: On the Unite TH you can activate/deactivate the Talkback

function. Press and hold the  symbol of the multifunction button > 2 seconds until " Talkback" is displayed. Select the desired Talkback "On" or "Off" option.

As a third option you will find "Request". When using this option, the speaker can select on the transmitter if he/she wants to accept ("Accept") or refuse ("Deny") the request.

Clear function: When the Talkback function is activated on the transmitter ("Master") and Unite RP-T receiver, you can use the Clear function to centrally turn off all activated microphones.

To do this, briefly press the  symbol of the multifunction button on the Unite TH. Then confirm the "Clear Mics" prompt with "Yes" or "No".

Button lock: In order to activate or deactivate the button lock function, press and hold the mute button (2) and the  or  symbol of the multifunction button for more than 3 seconds.

6. **Coloured ring, replaceable**

7. **Type plate**

8. **Charging contacts:** The built-in battery is charged via the charging contacts when the device is inserted into the charger. Make sure to insert the device fully into the charging slot so that the charging contacts have proper contact.

9. **USB port, Type C:** You can use this connector to charge the integrated battery via a USB power adapter. Furthermore, you can connect the handheld transmitter to the USB Type C port on a Unite charger to charge it or to pair it with other devices.

## Status Indicator

### During Operation:

Indicator light	Operating status
Off	Device is switched off
Flashing yellow slowly	<ul style="list-style-type: none"> <li>• Ready to operate and battery status &gt; 10%</li> <li>• Out of range (in sub-master mode only)</li> </ul>
Yellow	In Request mode: <ul style="list-style-type: none"> <li>• Connection established, but no audio transmission;</li> <li>• Battery status &gt; 10 %</li> </ul>
Green	Connection established, audio transmission running (microphone open or another audio source is used) and battery status > 10%
Flashing green slowly	Microphone is muted
Flashing red slowly	Low battery level < 10%
Flashing red/green rapidly	Firmware update is running
Red	Device is starting
Flashing red rapidly	Critical error

### In The Charger:

Indicator light	Operating status
Off	Device is switched off
Flashing green slowly	Charging 0 - 100%
Green	Battery is charged

Indicator light	Operating status
Flashing yellow slowly	Pairing information is being copied from the transmitter
Yellow for 10 seconds	Device information is copied successfully to charger/devices
Flashes red slowly for 10 seconds	<ul style="list-style-type: none"> <li>• Too many transmitters in the charger when pairing is initiated</li> <li>• Other pairing error</li> </ul>
Flashing green/yellow rapidly	Device is being localised
Flashing red rapidly	Charging error

## Display

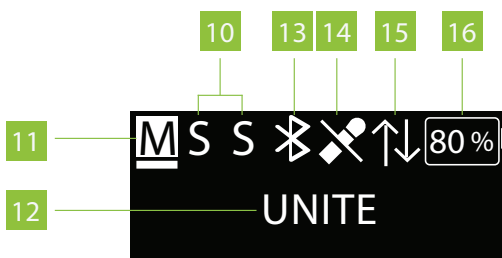

### 10. All active speakers:

Ⓜ = "Master"

Ⓢ = 1st "Sub-Master" or 1st speaker (Unite RP-T)

Ⓢ = 2nd "Sub-Master" or 2nd speaker (Unite RP-T)

(The highlighted display shows if the "Master", 1st "Sub-Master" or 2nd "Sub-Master" is active)

### 11. The underline displays if the device has been configured as a **Master or Submaster**:

Ⓜ = Master

Ⓢ = Submaster

### 12. Current channel name



13. **Bluetooth® status** (various symbols; depending on the status):



Bluetooth activated



Bluetooth connected

14. **Microphone status:**



Microphone muted



Microphone active

15. **Active, bidirectional talkback connection** (Full-Duplex connection) between:

‣ "Master" and a Unite RP-T receiver

‣ "Master" and a "Sub-Master"

The  symbol is only displayed on the connected devices during an active talkback connection.

The other devices of a group display a highlighted "S" during an active talkback connection between two devices.

16. **Remaining battery capacity**



For more details about the menu, please read the [Menu Items](#) section of this manual.

# HANDLING

Avoid holding the handheld transmitter at the top or bottom.

You could cover the integrated antennae and therefore reduce the range. Always hold the handheld transmitter in the middle.

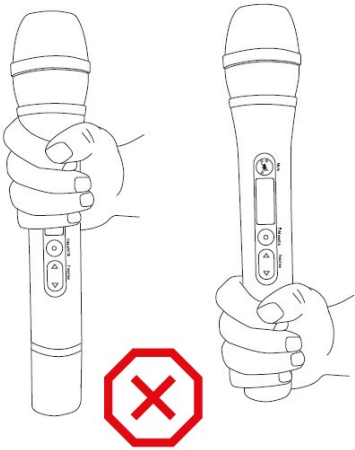

Wrong hand position

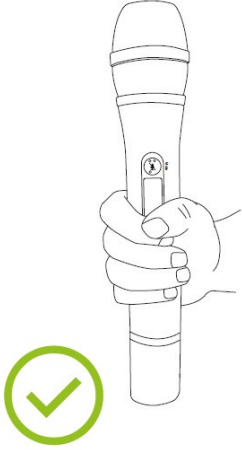

Correct hand position

# GENERAL OPERATION



Before using the handheld transmitter for the first time, you must charge the built-in battery. Please use an appropriate Unite charger or the USB connection.

Switch on the transmitter by pressing the on/off button (4).

- › In order to establish an audio connection between a transmitter and one or more receivers, **all devices must be paired together**. See the "Pairing" section for more information.
- › All devices are supplied with the group ID 256 and fixed audio encryption allowing quick and easy initial use. This allows a fast and easy first use, since there is no pairing required for the open group ID range between 150 and 256.
- › The transmitter will only transmit the audio signal on a channel with a predefined channel name. If there are several transmitters in a group between 150 and 256, the channel for the respective transmitter can be selected on the receiver (see the "Set the Channel Name" paragraph in the "Pairing" section for more information).



For more details about the menu, please read the [Menu Items](#) section of this manual.

# MICROPHONE GAIN AND NOISE SUPPRESSION

The Unite TH handheld transmitter provides various options to adjust the microphone gain and noise suppression automatically or manually. These options are enabled by an integrated digital signal processor (DSP).

You will find the settings of these two DSP effects in the menu at "Audio" > "Input Effects".

At the factory the "ALC" (Automatic Level Control) and "Noise Canceller" are activated.

- › If the **"ALC" function** is activated, the device performs an adjustment of the microphone gain to ensure that the signal is as evenly loud as possible. The result is a natural compression effect – the integrated digital signal processor (DSP) responds to the volume of the incoming signal and automatically increases the volume of quiet signals while limiting loud signals. This results in a very constant volume, which increases the intelligibility of speech significantly.



If the "ALC" function is active, the microphone gain cannot be adjusted manually any longer. The appropriate menu displays "ALC active!".

- › The **"Noise Canceller" function** almost completely eliminated continuously occurring background noise and attenuates punctual background noise. In contrast to the "Noise Gate" function, the "Noise Canceller" is also active when you speak into the microphone.

## How to Use the ALC Function

The ALC function provides two options:

- › "Near" for using the microphone close to the mouth
- › "Far" for using the microphone at chest height

You can find both option in the menu at "Audio" > "Input Effects" > "ALC".

When using the **"Far"** setting, the ALC function will activate at a **lower speech volume**. When using the **"Near"** setting, you must hold the microphone at a **maximum distance of 15 cm to the mouth**. Furthermore, the automatic control range of the "Far" setting is higher than of the "Near" setting.

This means: Due to the higher microphone gain when selecting the "Far" setting, your freedom of movement is bigger compared to the "Near" setting.

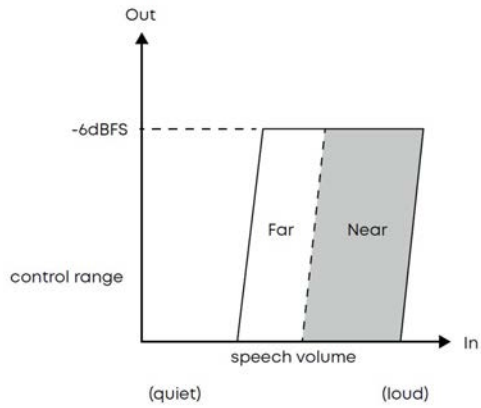

### "FAR" SETTING

The factory setting "Far" is selected, with which you can optimally use the microphone at a distance of approx. 15 to 25 cm to the mouth (chest height).

The advantage of this setting results in an arm-friendly posture and a slightly greater freedom of movement.



Due to the higher gain and the bigger control range, loud background noise can affect the ALC function.



Figure 1-3 How to hold the microphone when using the "Far" setting

## "NEAR" SETTING

The "Near" setting is alternatively available allowing you to use the microphone closer to the mouth (below the chin). In an environment with loud background noise, it is useful to hold the microphone closer to the mouth so that the ALC function can better distinguish between speech signal and background noise.



Figure 1-4 How to hold the microphone when using the "Near" setting

## Manual Adjustment of the Microphone Gain Without Using ALC

If you do not want to use the ALC function (e.g. due to extreme background noise in your environment), you can manually reduce the microphone gain for loud speakers and increase the microphone gain for quiet speakers. In both cases use the On/Off and menu button (4) to access the menu at "Audio" > "Volume" > "Internal Mic".

If you deactivate the ALC function, please make sure that you keep a constant speaking distance to the mouth to achieve an optimum speech transmission.

Avoid holding the microphone closer or further away from your mouth. Also avoid turning your head while speaking.



Figure 1-5 Optimum speaking distance when the ALC function is deactivated

## Compressor and Noise Gate

The ALC and Noise Canceller functions are intelligent DSP algorithms which react to an incoming signal. If very loud and various background noise occurs in your environment, the algorithms can no longer distinguish between microphone signal and noise so that they do not work optimally.

This is illustrated by the following example: During a sightseeing tour on the upper floor of an open bus, a strong airflow occurs and enters the microphone capsule. The DSP algorithms ALC and Noise Canceller can not distinguish between airflow and speech signal.

For such situations a **compressor is available** in addition to the automatic control of the microphone gain (ALC). You will find this function in the menu at "Audio" > "Input Effects" > "Compressor".

The compressor statically **increases the volume of soft speech signals**.

The following options are available:

- > "low" = compression 2:1
- > "high" = compression 4:1
- > "less pop noise" = relatively high degree of compression to contain explosive sound

In addition to this, you can use the **Noise Gate function** instead of the intelligent Noise Canceller. The Noise Gate starts to work at a **defined threshold** and **eliminates background noise during pauses in speech**.

You will find this function in the menu at "Audio" > "Input Effects" > "Noise Gate".



# BLUETOOTH® INTERFACE

The Bluetooth® function of the transmitter is used as an audio interface for the following applications.

- › **For Bluetooth® headphones (Use of the Talkback functionality):** You can connect a headphone via Bluetooth®. This allows listening to the talkback signals of the Unite RP-T receiver and Sub-Master devices.
- › **For playback::** You can also use the Bluetooth® function to playback audio signals from external sources (e.g. smartphones or computers).



If the Bluetooth® is used for the playback of external audio sources, we recommend using the DSP effect **Ducker**. The **Ducker** decreases the signal of an external audio source as soon as someone is speaking into the microphone capsule ensuring optimal speech intelligibility.



For more information, please refer to the "External Interfaces" section in this manual.

# PAIRING

## Creating a Pairing

In order to communicate with each other, the **transmitter and receivers must have the same group ID, encryption key and channel name**. Only then they can communicate with each other. There will be no communication with receivers that do not have the same pairing information. This is illustrated in the figure below:

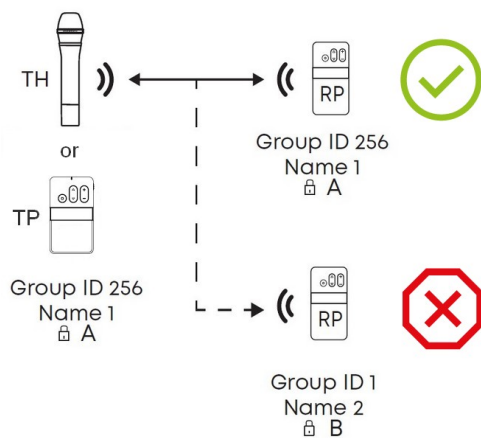

The required audio encryption key is generated in the Unite Charger (Unite CC, CR, CDD-8/4 or CDS-4/2) or via the Unite Manager software. During the pairing process, it is first stored on the charger, and then it is transferred to the transmitter and receiver in the charging compartments.

In this context, please also note the **position of the switch** on the charger. The switch must be set to the "*Pair & Charge*" position so that the pairing information can be transmitted from the Unite charger to the transmitters and receivers.

There are three different ways to pair Unite transmitters with receivers:

1. Via an individual charger.



Pairing is possible with the **Unite CC, CR, CDD-8/4** and **CDS-4/2 only**.

2. Using the Unite Manager Software on a PC.
3. Via dynamic channel search.

## Encryption

The audio data is always encrypted with an AES-256 code to ensure a secure transmission against unauthorized listening.



The required key will be generated within the charging unit itself and transmitted to the transmitters and receivers during the pairing process.

As the encryption code is not transmitted wirelessly, the system is better protected against unauthorized listening. Should the receiver receive a differently encrypted audio signal for which no encryption code has been saved, the received audio signal will be muted. The receiver display will also alternate between showing the relevant channel name and the "KEY!" error message.

The encryption of the audio signal is explained schematically in the "Encryption" diagram below.

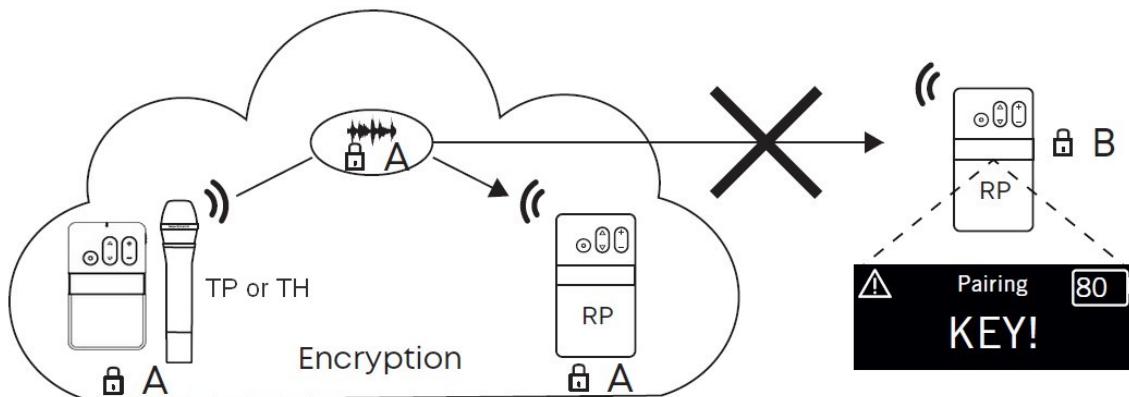

The group IDs in the range of 150 to 256 uses a factory-defined key that cannot be changed. You can use this group ID for a system without pairing.



The transmitter and receiver can only communicate if the settings for group ID, channel name and encryption match. Transmitters cannot communicate with receivers that do not have the same pairing information.



If you need a specific encryption key, you need to use a group ID between the range of 1 and 149. Refer to the **Pairing** section of your device to change the group ID.

## Group ID

The group ID refers to devices that can be combined to a virtual group. For example, all devices of a building, a travel group or a conference room.

## Using with Group ID 150-256

**By default**, the transmitters and receivers are supplied with the group **ID 256**. A common factory-set audio encryption key, which cannot be changed, is used for the group ID range of 150 to 256.

The audio encryption key ensures **additional security** against unauthorised listening during the wireless transmission. Due to the factory-set audio encryption key the devices within the group ID range of 150 to 256 can connect to each other without pairing via the charger. In this case receivers can connect to transmitters via the dynamic channel search.

Example: Via the dynamic channel search, a receiver which is set to the group ID 160 will find all transmitters which are active and also set to the group ID 160. The receiver will not find transmitters beyond the set ID range of 160.



When using **several transmitters** (e.g. Unite AP4 and several Unite TP) with the same group ID at the same time, make sure that the individual channel names differ from each other! Otherwise this can cause connection problems with the receivers!

## Using with Group ID 1-149

If several receivers are to be divided into different groups with an individual encryption, for each group an individual group **ID between 1 and 149** can be assigned. A **separate audio encryption key is generated** for an individual group ID in order to ensure additional security against unauthorized listening during the wireless transmission. This audio encryption key is generated during the pairing process, stored in the charger and transmitted from the charger to the transmitter and receiver, along with the channel name and group ID.

The receivers can only connect to a transmitter with which they have been paired via the charger. If the group ID is subsequently set manually on a receiver which has not been paired, no connection can be established to the transmitter with the encrypted group ID, because the receiver does not have the audio encryption key.

## Changing the Group ID

1. Press and hold the menu button for 2 seconds to activate the main menu.
2. Use the multifunction button to select "System" from the menu.
3. Press the menu button to open the required submenu.
4. Use the multifunction button to select the "Group ID" submenu.
5. Press the menu button to set an group ID.
6. Use the multifunction button to select the desired group ID.

7. Press the menu button to confirm the selected group ID.



Make sure to select the same group ID for all devices of a desired group. Only devices that have the same group ID can communicate with each other. Transmitters with other group IDs are hidden. See the following diagram.

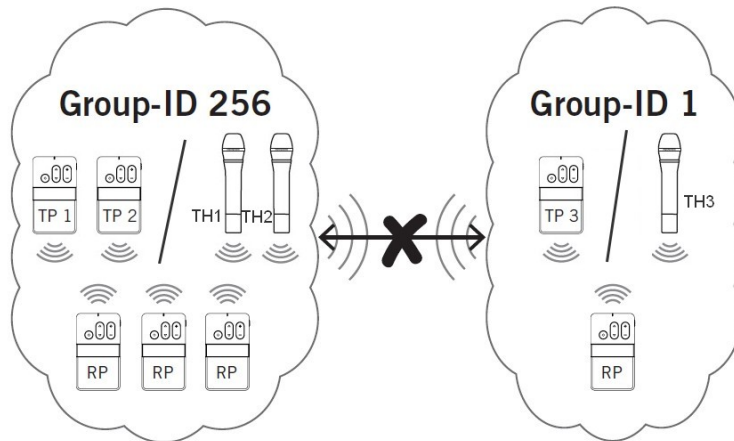

## Setting the Channel Name

Devices that are grouped with one group ID can transmit multiple audio channels via the same group ID.

In order to differentiate between audio channels from several transmitters on the receiver, enter a five-digit name for the channel on the transmitter. Proceed as described in the following:

1. Hold down the menu button on the transmitter for more than 2 seconds to activate the main menu.
2. Use the multifunction button to select "System" from the menu.
3. Press the menu button to open the required sub-menu.
4. Use the multifunction button to select the "Channel Name" sub-menu.
5. Press the menu button to set the channel name.

6. Use the multifunction button to scroll through the characters. When the desired character appears, confirm using the menu button. You can input max. five characters.

As soon as you select the configured transmitter on the receiver, the defined name will be displayed on the receiver's display.

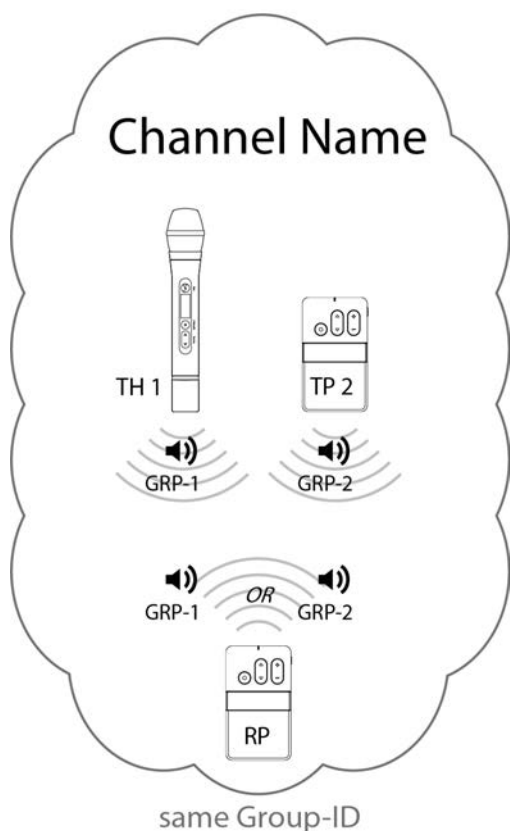



Figure 1-6 Example of two transmitters with different channel names and a receiver that can find and switch between both transmitters.

7. Change the channel on the receiver via the dynamic channel search. Press the  or  symbol of the channel buttons and confirm the displayed "Scan for channels?" question with "Yes" by pressing the menu button. Depending on the DECT environment and the distance to the transmitter, it may take several seconds to find the channels.

8. Press the ▲ or ▼ symbol of the channel buttons to select the transmitter (channel name). In order to confirm press the On/Off and menu button.



Once the channel search is started, the receiver will lose its connection to the previous transmitter.



# USING AS A SUB-MASTER

The Unite transmitter can be configured in a virtual device mode (Sub-Master). This allows up to two additional speakers to be integrated into a device group.

In the Sub-Master mode, the transmitter can set up an exclusive connection to a Master device. In one group, a **maximum of two Sub-Masters** can be active and connected to one Master device.

The connection between a Sub-Master and a Master device is technically the same as the connection between a Unite RP-T with activated "Talkback" function and a "Master". The difference is that the connection between a Unite RP-T and a Master is temporary, while the connection between a Sub-Master and a Master is permanent. In this case the audio channel is permanently open, but it can be muted by pressing the "Mute" button on the Sub-Master.

In addition, there are of course still possibilities to connect external audio sources to the Sub-Master. All audio signals of the Sub-Master are distributed via the Master (Broadcast) and can be routed to the Master. These options can be found in the Master menu at "Talkback" --> "Audio Routing".

## **Examples of up to 3 open microphones in the following device combinations:**

- > 1 x Master + 2 x Sub-Master
- > 1 x Master + 2 x RP-T (Talkback )
- > 1 x Master + 1 x Sub-Master + 1 x RP-T (Talkback)

## Configuring a Sub-Master

In order to configure the Unite transmitter as a Sub-Master, proceed as described below:



1. Use the On/Off and menu button to access the menu "System" --> "Device Mode".
2. Select the Sub-Master option.
3. Confirm the selected option with the On/Off and menu button.
4. Restart the transmitter by pressing the On/Off and menu button.
5. The transmitter reconfigures itself. This can take 1 - 2 minutes.
6. You can reconfigure the device as "Master" at any time.



**Unite TH only:** When you configure a transmitter as a Sub-Master, a **factory setting for the Sub-Master** will be **automatically activated**. This sets the value for the ALC function to "Far" and for the Noise Canceller function to "Low". This is also the factory setting for the configuration as Master.

## Connecting a Sub-Master to a Master

In order to connect a Sub-Master to a Master, you have to perform a channel search. Please proceed as described below:

1. Press the  or  symbol of the multifunction button (5) and start the dynamic channel search.
2. The basic conditions to establish a connection must be guaranteed. Refer to the "Pairing" section of your device in this manual for more information.

Alternatively, you can transmit the pairing information via a charger. As a Sub-Master, the transmitter will receive the channel name, group ID and audio encryption key from the charger like a Unite RP or RP-T.

# USING WITH A UNITE AP4 ACCESS POINT

In conjunction with a Unite AP4 access point, the Unite transmitter can be used as a wireless microphone. In order to establish a connection to a Unite AP4, the transmitter must be configured as "AP4 Mic (Sub-Master)" via the menu.

This mode is technically equivalent to a Sub-Master, which can establish an exclusive connection to the Unite AP4 as the Master.

## Configuring As AP4 Mic (Sub-Master)



1. In order to configure the Unite transmitter in the Sub-Master mode, select in the menu "System" > "Device Mode" > "AP4 Mic (Sub-Master)".
2. Confirm the selected option with the On/Off and menu button.
3. Restart the transmitter by pressing the On/Off and menu button.

The transmitter reconfigures itself. This can take 1 - 2 minutes.

4. You can reconfigure the device as Master at any time.

## Connecting to a Unite AP4 Master

In order to use the Unite transmitter as a wireless microphone with a Unite AP4, you must perform a channel search.

Press the  or  symbol of the multifunction button (4) on the transmitter to start the dynamic channel search. The basic conditions to establish a connection must be guaranteed (refer to the "Pairing" section of your device for more information).

The second way to establish a connection between the Unite transmitter and Unite AP4 is to use the Unite Manager PC software for pairing. Please refer to the [Unite Manager PC software manual](#).

# MAINTENANCE



Protect the handheld transmitter from humidity, knocks and shock. Avoid dropping the transmitter at all times.

## Cleaning

For cleaning the plastic surface of the handheld transmitter, use a soft cloth moistened with a solvent-free plastic cleaner.

As soon as your microphone sounds dull, you should clean the integrated pop shield:

1. Unscrew the microphone grille (1) anti-clockwise.

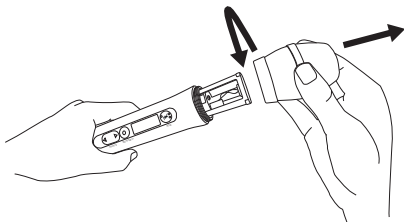

2. Pull out the foam pop shield, if necessary use tweezers.



3. Clean it under clear running water.

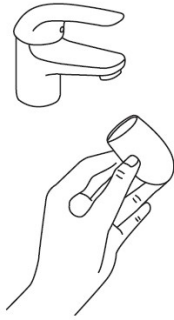

4. If necessary, use a mild washing-up liquid.
5. Dry it afterwards with a hairdryer or allow it to dry overnight.
6. Clean the microphone grille both inside and out with a slightly moistened cloth or a soft brush under clear running water and allow it to dry overnight.



The microphone grille **cannot** be cleaned in a dishwasher.

7. Place the dry pop shield inside the microphone grille and replace the microphone grille by screwing it on clockwise.

## Replacing the Colored Ring

1. Press the colored ring with two fingers slightly together, grab the small loop and pull the colored ring carefully from the transmitter.

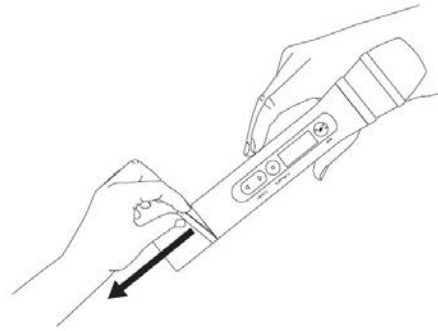
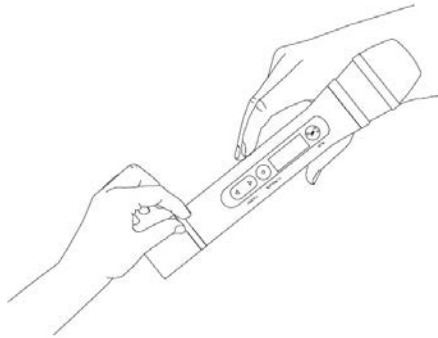

2. Slide the new colored ring from the bottom onto the transmitter. Make sure that the colored ring is not twisted.

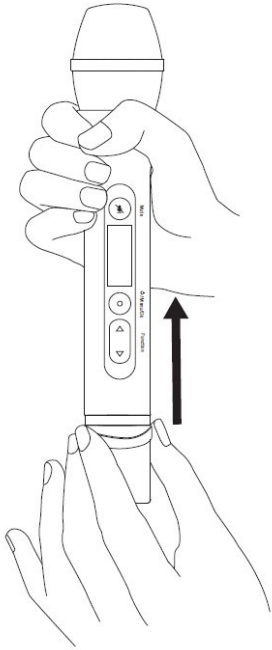

# UNITE RP / RP-T

The **Unite RP and RP-T bodypack receivers** is used for **speech applications** - e.g. guided tours, multilingual interpretation, intercom and assistive listening. **Up to three guides and/or speakers** can be added. The Unite RP-T transmitter also has an **integrated microphone** and **talkback function** to allow dialogue within a group.

This chapter will explain how to operate the Unite RP and RP-T bodypack receivers.

# DESCRIPTION

## Device

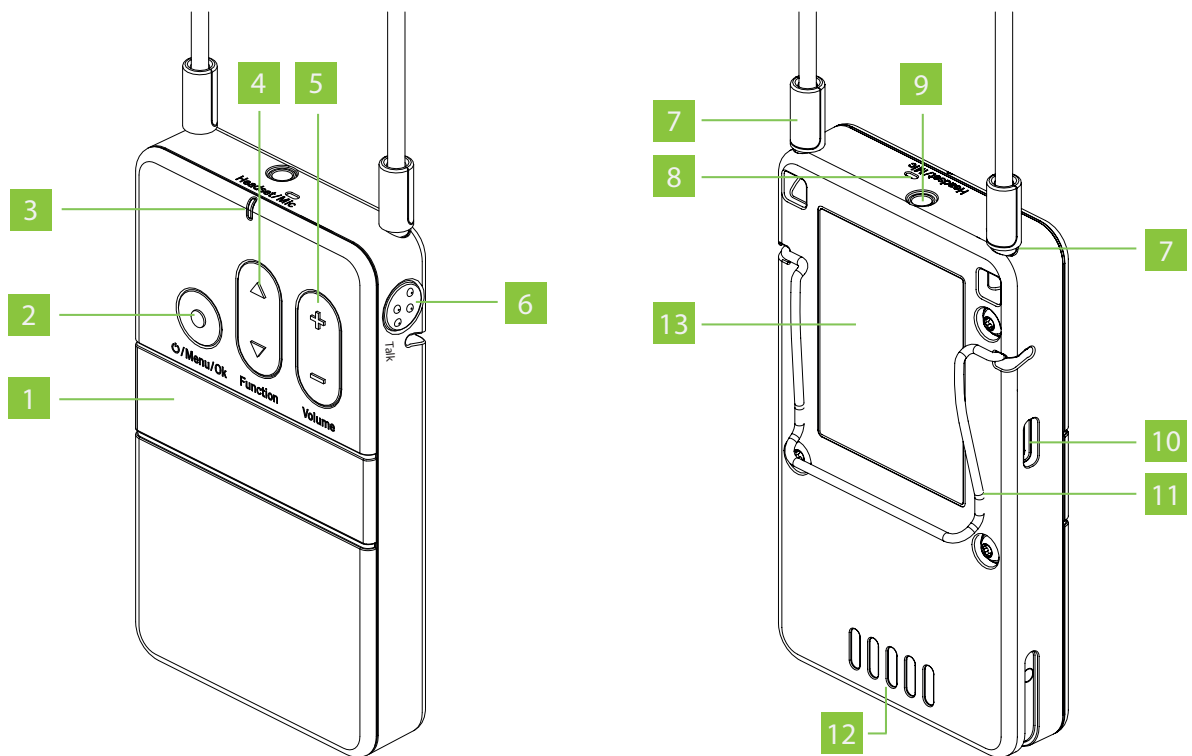

1. **Display:** The display indicates the channel name, battery status and different menus. Refer to the Display section below for more information.
2. **On/Off and menu button :** Use the on/off button to turn the receiver on or off. To switch off the device, hold down the button for 5 seconds. In order to activate the main menu, hold down the button for 2 seconds. Use the menu button to confirm settings.
3. **Status indicator light:** Refer to the Status Indicator section below for more information.
4. **Multifunction button:** With this button you can enter the channel selection menu and select a channel. If you are in a menu, you can scroll through the menu to make various settings.



5. **Volume button:** Use this button to adjust the volume of any connected headphones/headsets/induction loops. With "+" the volume is increased, with "-" the volume is reduced.
6. **(RP-T only) Talkback button:** With this button, you can ask the tour guide a question via the integrated microphone or the microphone of a connected headset.
7. **Neck strap attachment:** Attach the supplied neck strap by pushing the pins at the end of the neck strap into the fastening holes. For safety reasons, the fastening will detach when pulled strongly.
8. **(RP-T only) Integrated microphone:** The integrated microphone is used for short queries to the tour guide. Maintain a distance of 10 cm from the microphone when speaking. For a best possible audio transmission we recommend using an external headset.
9. **Headphones/headset/induction loop connector:** With Unite RP, you can connect headphones or an induction loop to the jack connection. With Unite RP-T, you can connect headphones, a headset or an induction loop to the jack connection.
10. **USB port, Type C:** You can use this connector to charge the integrated battery pack via a USB power adapter. Furthermore, you can connect the bodypack receiver to the USB Type C port on a Unite charger to charge it or to pair it with other devices.
11. **Belt clip:** The belt clip allows you to attach the device to clothing such as a waistband or belt.
12. **Charging contacts:** The built-in battery is charged via the charging contacts when the device is inserted into the charger. Make sure to insert the device fully into the charging slot so that the charging contacts have proper contact.
13. **Type label:** The type label provides information about the name, article number, certification numbers, hardware version, serial number and production date.

## Status Indicator

### During Operation:

Indicator light	Operating status
Off	Device is switched off
Flashing yellow slowly	<ul style="list-style-type: none"> <li>• Ready to operate and battery status &gt; 10%</li> <li>• Out of range from the transmitter</li> </ul>
Yellow	<b>RP-T only:</b> Connection established and battery status > 10 %
Green	<b>RP:</b> Connection established and battery status > 10% <b>RP-T:</b> Connection established, talkback is running and battery status > 10%
Flashing red slowly	Low battery level < 10%
Red	<ul style="list-style-type: none"> <li>• Device is starting</li> <li>• Firmware update is running</li> </ul>
Flashing red rapidly	Critical error

#### In The Charger:

Indicator light	Operating status
Off	Device is switched off
Flashing green slowly	Charging 0 - 100%
Green	Battery is charged
Flashing yellow slowly	Pairing information is being copied from the transmitter/charger
Yellow for 10 seconds	Device information is copied successfully to device
Flashes red slowly for 10 seconds	Pairing error
Flashing green/yellow rapidly	Device is being localised
Flashing red rapidly	Charging error

## Display

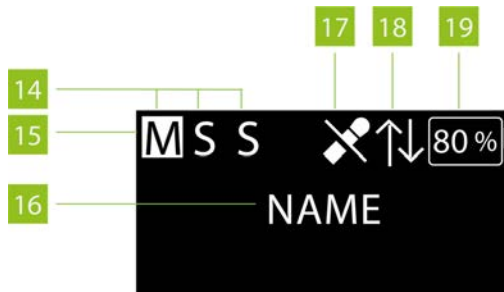

14. **All active speakers:**

M = "Master"

S = 1st "Sub-Master" or 1st speaker (Unite RP-T)

S = 2nd "Sub-Master" or 2nd speaker (Unite RP-T)

15. The highlighted display shows if the **"Master", 1<sup>st</sup> "Sub-Master" or 2<sup>nd</sup> "Sub-Master" is active**

16. **Current channel name**

17. **RP-T only** (various symbols; depending on the status):



Microphone muted



Internal microphone activated



Headset activated



Auto Mic activated: The device automatically recognises which microphone source is used.

When the headset socket is used, a query is ensued if a headset or headphone is used.

18. **Active, bidirectional talkback connection** (Full-Duplex connection) between:

⌘ "Master" and a Unite RP-T receiver

⌘ "Master" and a "Sub-Master"

The  symbol is only displayed on the connected devices during an active talkback connection.

The other devices of a group display a highlighted "S" during an active talkback connection between two devices.

#### 19. **Remaining battery capacity**



For more details about the menu, please read the [Menu Items](#) section of this manual.

# HOW TO WEAR THE BODYPACK RECEIVER

There are two options for wearing the bodypack device:

## Neck Strap



When using the supplied strap, you can wear the bodypack device around the neck. For safety reasons, the fastening will release when pulled strongly.

- › Put the pins at the end of the strap into the fastening holes.
- › Put the strap around the neck.

## Belt Clip



When using the belt clip, you can attach the bodypack device to clothing such as a trouser or skirt waistband.

# OPERATION

## General Operation Process



Before using the bodypack receiver for the first time, you must charge the built-in battery. Please use an appropriate Unite charger.

1. Connect a headphone or induction loop to jack socket (9) (see the " " section below for more information).



With the RP, you can only connect headphones and an induction loop. With the RP-T variant, you can also connect a headset instead of headphones.

2. Hold down the on/off button (2) to switch on the receiver (see the " " on page 161 section below for more information).
3. Use the volume button (5) to adjust the volume of the headphones/headset/induction loop.



All devices are supplied with the group ID 256 and fixed audio encryption allowing quick and easy initial use.

If you require several device groups or an audio transmission even more secure against eavesdropping, to avoid listening by other groups using Unite devices, follow the steps in the "Pairing" section of the Unite TP, or the "Pairing" section of the Unite TH transmitter to create a new pairing.

The transmitter and receiver can only communicate if the settings mentioned in this chapter match. Transmitters cannot communicate with receivers that do not have the same pairing information. This is shown in the following diagram:

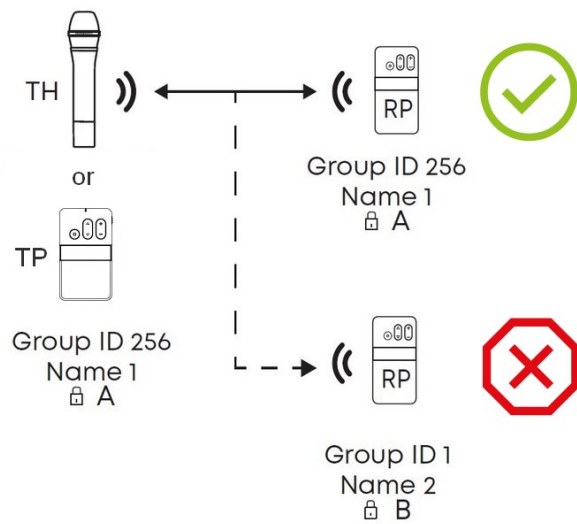

For more details about the menu, please read the [Menu Items](#) section of this manual.

## Connecting Headphones / Headset / Induction Loop

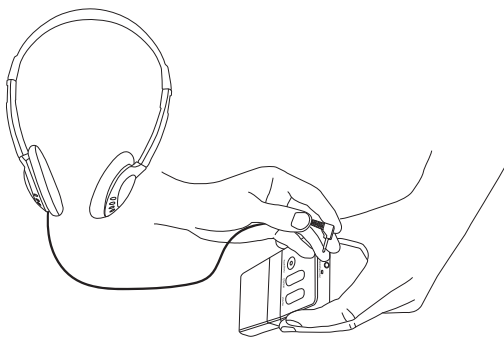

### UNITE RP

- > You can connect headphones to the mini jack socket (9).
- > For those who are hearing impaired, you can connect an induction loop (e.g. Televic IL 200) to the mini jack socket (9) instead of headphones.



## UNITERP-T

- > You can connect headphones or a headset to the mini jack socket (9) .
- > For those who are hearing impaired, you can connect an induction loop (e.g. Televic IL 200) to the mini jack socket (9) instead of headphones.

### Switching On or Off

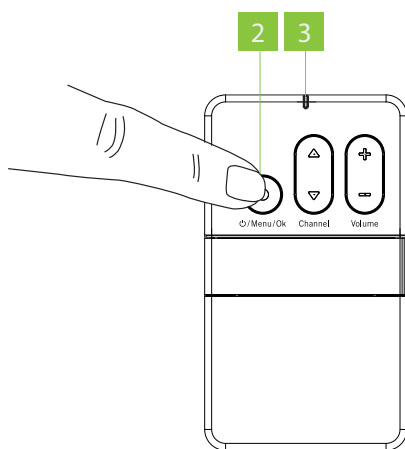

- > To switch on the bodypack receiver, briefly press the **⏻/Menu/Ok** button (2).
- > In order to switch off the bodypack receiver, press the button (2) for approx. 5 seconds.
- > When the device is switched on, the status indicator displays the operating status information (see table below).

Indicator light	Operating status
Off	Device is switched off
Flashing yellow slowly	<ul style="list-style-type: none"><li>• Ready to operate and battery status &gt; 10%</li><li>• Out of range from the transmitter</li></ul>
Yellow	<b>RP-T only:</b> Connection established and battery status > 10 %

Indicator light	Operating status
Green	<b>RP:</b> Connection established and battery status > 10% <b>RP-T:</b> Connection established, talkback is running and battery status > 10%
Flashing red slowly	Low battery level < 10%
Red	<ul style="list-style-type: none"> <li>• Device is starting</li> <li>• Firmware update is running</li> </ul>
Flashing red rapidly	Critical error

> When the Unite TP bodypack receiver is switched on, the main screen below will be displayed indicating that the receiver is ready for operation.

> The individual symbols mean:

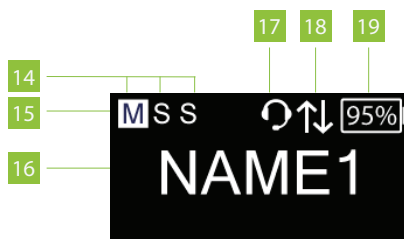

14 Display of all active speakers (Master, 1<sup>st</sup> submaster, 2<sup>nd</sup> submaster)

15 Highlighted display of current type of speaker (Master, 1<sup>st</sup> submaster or 2<sup>nd</sup> submaster)

16 Current channel name

17 (RP only): Headset connected

18 Talkback function activated

19 Display of remaining battery capacity

## Adjusting the Volume

Use the volume button (5) to adjust the volume of connected headphones, headset or induction loop.

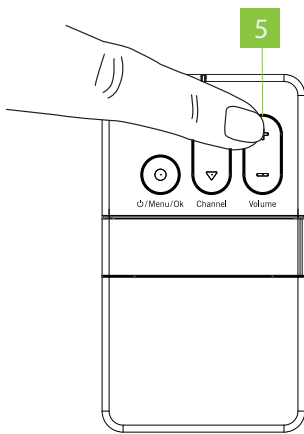

- > Press "+" to increase the volume.
- > Press "-" to reduce the volume.



Please note the safety instructions regarding too high volume.

## Speaking to the Guide (RP-T Only)

The Unite RP-T bodypack receiver has a talkback button (6) and an integrated microphone (8) for talking to the guide during a tour.

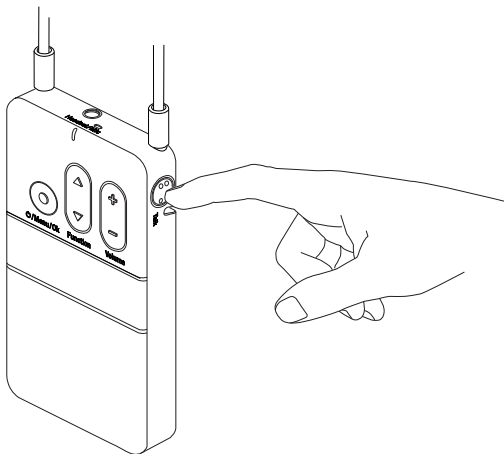

- › If the "Push" setting is selected in the "Talkback" menu, press and hold the talkback button as long as you speak into the microphone of a connected headset or the integrated microphone (8) when no headset is connected. Refer to the "Menu Items" section.
- › If the "Toggle" setting is selected in the "Talkback" menu, press the button to activate the microphone of a connected headset or the integrated microphone if no headset is connected. When you press the button a second time, the microphone is deactivated. Refer to the "Menu Items" section

When the talkback button (8) is pressed, the active function is also displayed by .



Please keep a distance of approx. 10 cm to the integrated microphone when speaking.



The integrated microphone was specially developed for the talkback function in conjunction with the Unite TP or TH transmitter for talking. For best audio transmission we recommend using an external headset.

# UNITE AP4

The **Unite AP4 Wireless Access Point** is used for **speech applications** - e.g. multilingual interpretation, intercom and assistive listening. With one access point, four audio channels can be wirelessly transmitted to an unlimited numbers of Unite receivers. Eight Unite AP4 can be synchronized for a maximum of up to 32 channels. It is also used for installation, monitoring, maintenance, configuration and pairing.

This chapter will explain how to install the Unite AP4 Access Point. The configuration/use will be explained in the [Unite Manager PC Software manual](#).

# DESCRIPTION

## Front View

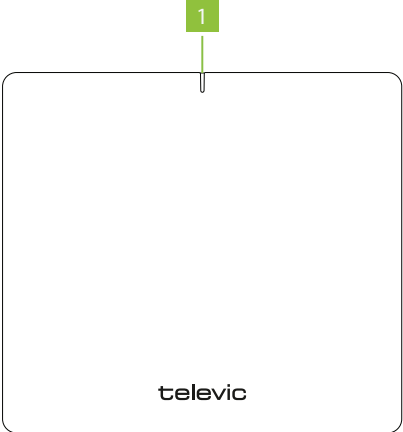

1. Status LED

## Rear View

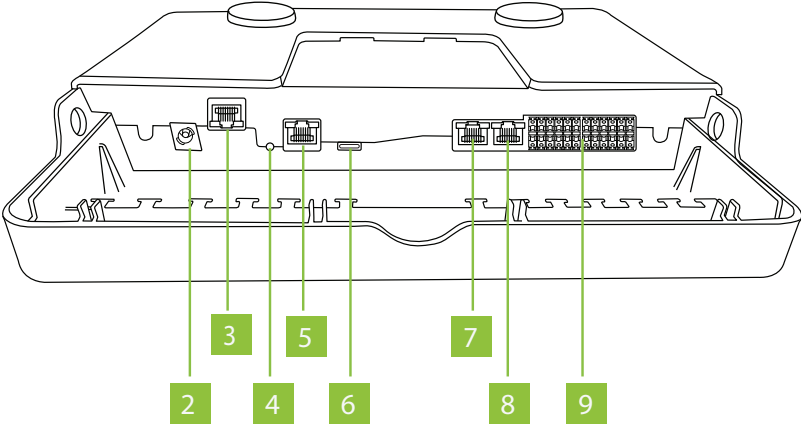

1. **DC connection** for the external, supplied power supply, 12 V DC / 3 A



Use only the power supply supplied by Televic.

2. **Dante® network connection** with Power over Ethernet (PoE) function, RJ-45-socket
3. **Reset button** to restore the factory settings
4. **LAN connection** for configuration via the Unite Manager Software, RJ-45-socket
5. **USB connection**
6. **Sync signal input** to cascade several Unite AP4, RJ-45-socket



Attention: No Ethernet connection!

7. **Sync signal output** to cascade several Unite AP4, RJ-45-socket



Attention: No Ethernet connection!

8. **Audio inputs/outputs**, channel 1 - 4, Phoenix®-terminal block socket for use with supplied Phoenix terminal blocks, contact spacing 3.5 mm

# INSTALLATION

In order to ensure that the Unite receivers receive radio signals as good as possible, make sure that the **front of the Unite AP4 unit points to the area where the Unite receivers will be operating.**

If reception problems occur, change the mounting position of the Unite AP4 in the room. Make sure that there is a line of sight between the Unite AP4 and the receivers. This can improve reception.

In order to install the Unite AP4 and to **connect the cable**, you must **remove the mounting plate** from the housing first. Please proceed as follows:

- Press the latches on the right and left hand side inwards.
- Remove the mounting panel downwards, refer also to the arrow in the drawing.

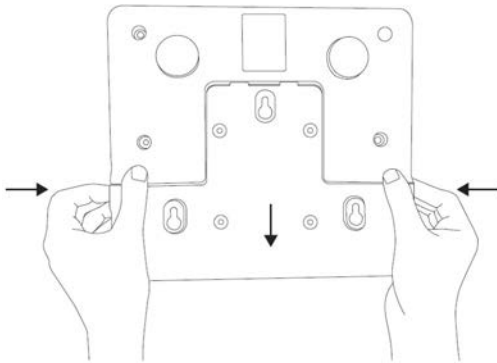

## Mounting to a Wall / Ceiling



Before mounting the Unite AP4 to the wall/ceiling, make sure that there are **no electrical, or gas lines or water pipes** behind the planned drilling locations. If necessary, check this with a line detector or ask an expert.



It is a significant hazard when electrical or gas lines or water pipes are damaged during drilling.





For wall mounting, use **appropriate wall plugs and screws**. Example: For a wooden wall use a universal screw, 4.5 x 30mm, pan head, e.g. WIROX®-0201010450303

1. Remove the cover plates from the mounting panel by pressing the large latch.

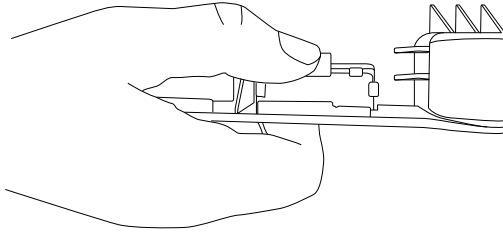

2. Route all required connecting cables through the openings of the mounting panel.

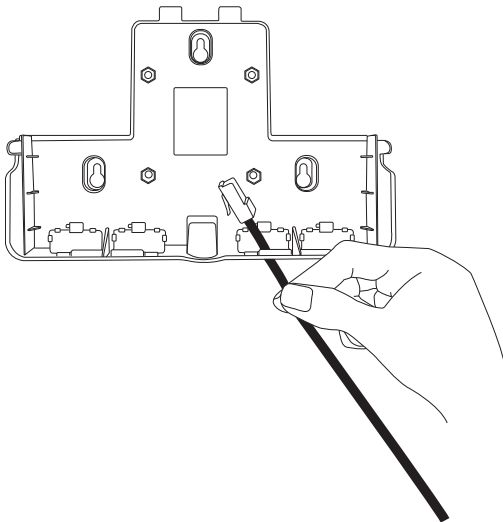

3. Mount the cover plates to the mounting panel according to the cable routing.

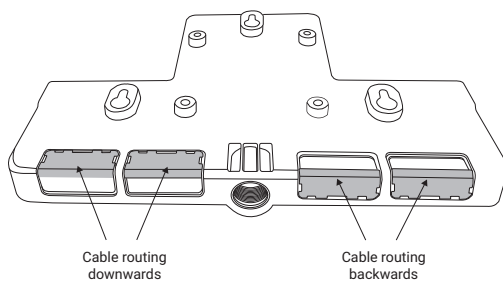

4. Mount the mounting panel to the wall or ceiling by using the three "keyhole openings" with appropriate screws.

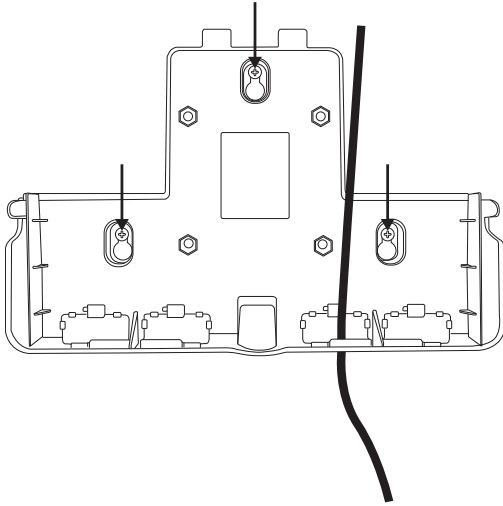

5. Connect the cables to the appropriate connections.

Attach the cable with a cable tie to the T-piece below the connection.

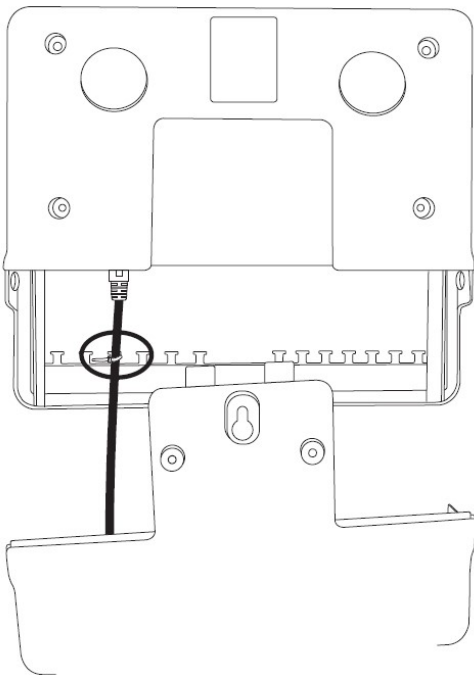

6. Put the device onto the mounting panel until the latches on the right and left hand side audibly click into place. Refer also to the installation instructions on the mounting panel.



Please make sure that the device is firmly mounted.

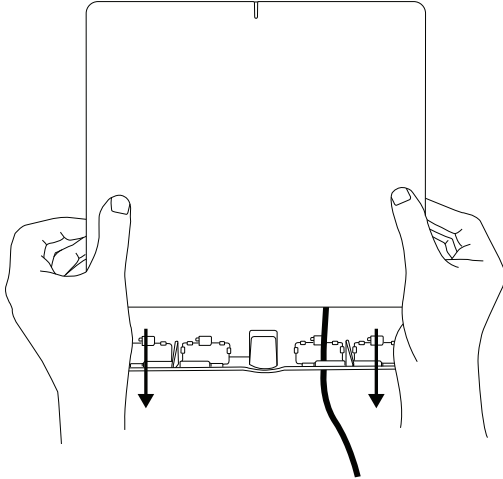

## Mounting on a Stand

1. Press the cover plates on the large latch from the mounting panel.

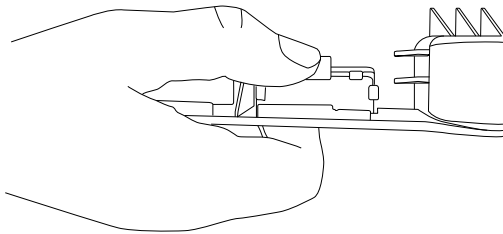

2. Route all required connecting cables through the openings of the mounting panel.

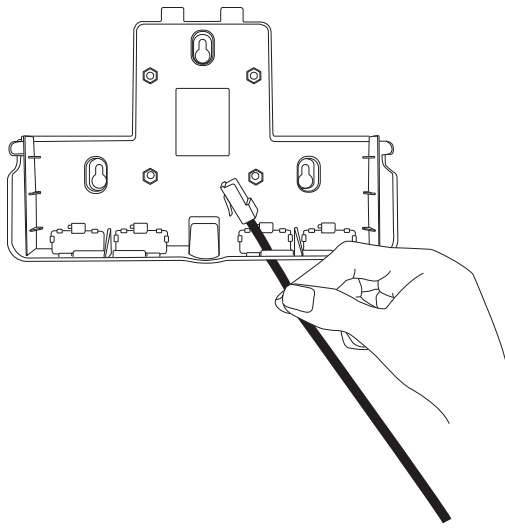

3. Attach the cover plates to the mounting panel according to the downward cable routing.

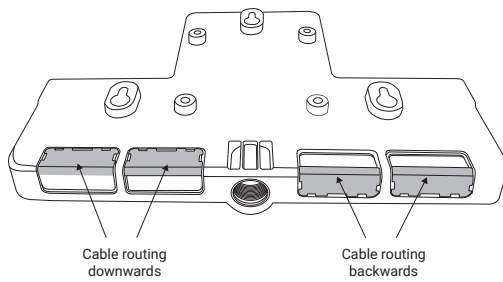

4. Connect the cables to the appropriate connections.

Attach the cable with a cable tie to the T-piece below the connection.

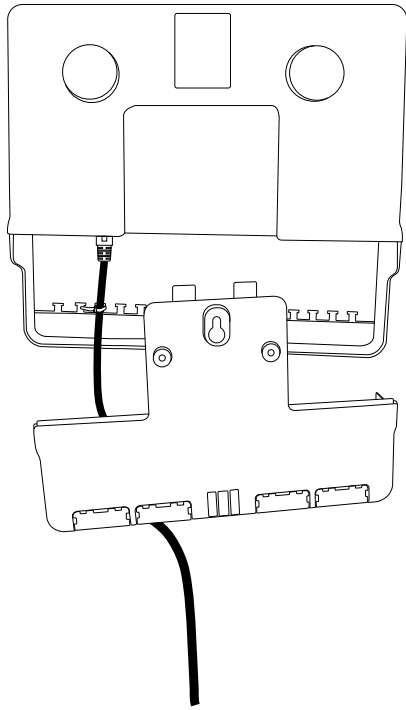

5. Replace the mounting panel until the latches on the right and left hand side audibly click into place.

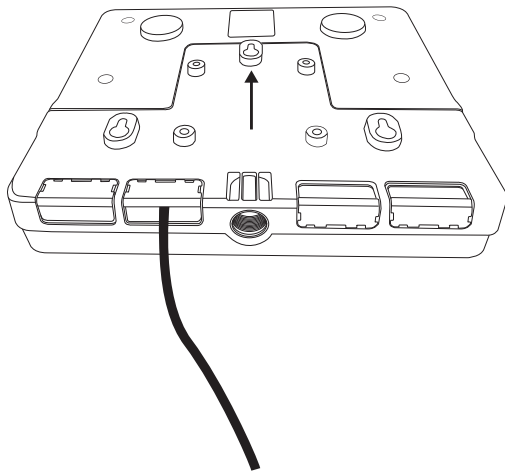

6. Mount the Unite AP4 on the thread of a tripod with 5/8 thread.

For tripods with a 1/2 " or 3/8 thread, delivery includes an appropriate adapter.

Upon request, you can screw this adapter into the 5/8 thread with a flat-head screwdriver.

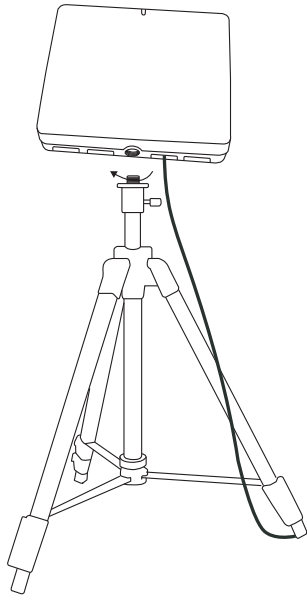

## Mounting on a VESA Adapter Plate

1. Attach a VESA 75 x 75 plate with 4 screws (included in the delivery) via the 4 holes to the mounting panel. The distances between the 4 holes are 75 mm each.

When selecting the screws, make sure that the **screw is flush** with the nut and **does not protrude** into the device.

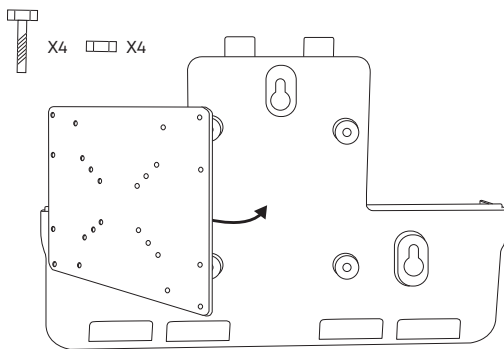

2. Fasten the 4 screws on the inside of the mounting panel with hex nuts. Size of the nut: M5.

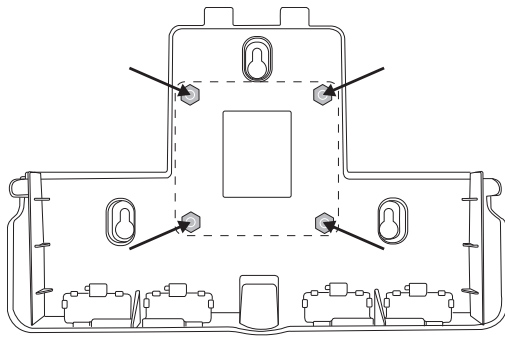

3. Remove the cover plates from the mounting panel by pressing the large latch.

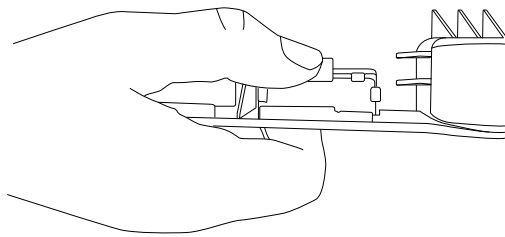

4. Route all required connecting cables through the openings of the mounting panel.

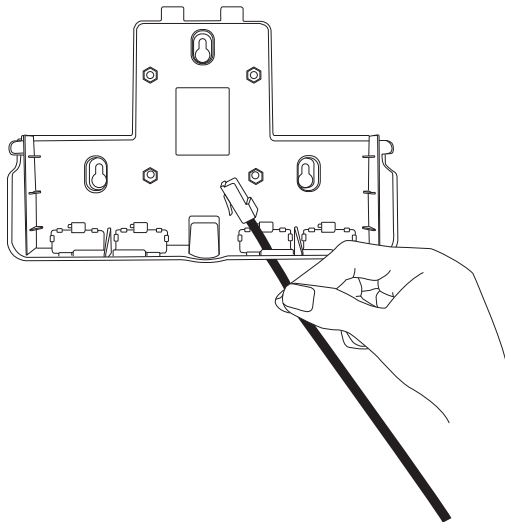

5. Mount the cover plates to the mounting panel according to the cable routing downwards.

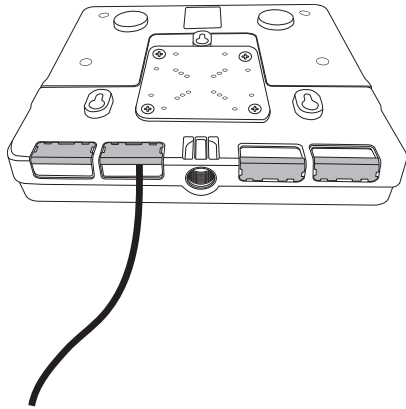

6. Connect the cables to the appropriate connections.

Attach the cable with a cable tie to the T-piece below the connection.

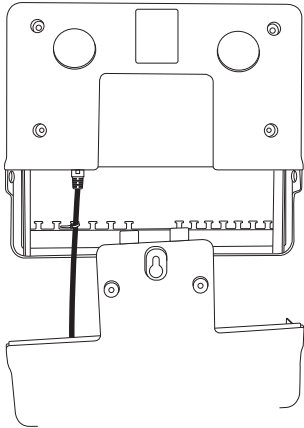

7. Replace the mounting panel until the latches on the right and left hand side audibly click into place.

Attach the Unite AP4 to the desired place via the VESA plate.



Make sure that the device is firmly mounted.



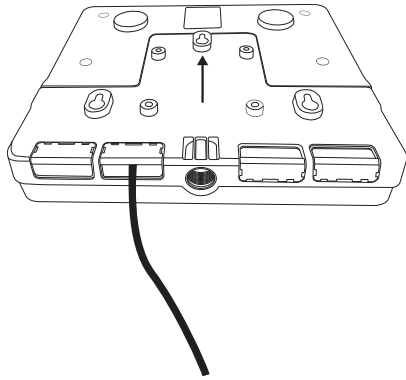

## Using a Secondary Safety Rope



The Unite AP4 has **two openings** through which you can route a secondary safety rope to **secure the Unite AP4** additionally against falling down.

In practice, it is the quality of the way in which the equipment is installed that influences the safety of suspension systems for lighting, PAs, monitors, decorations and other objects in the production and event business which are installed using fixing devices intended to allow the equipment to be used in different places (e.g. spigots and sleeves or C hooks).

Such applications thus require a secondary safety component. (Source: DGUV Safety for Events and Productions Version 3.2/2015-10) For the preferred direction of threading, refer to the arrow in the drawing.

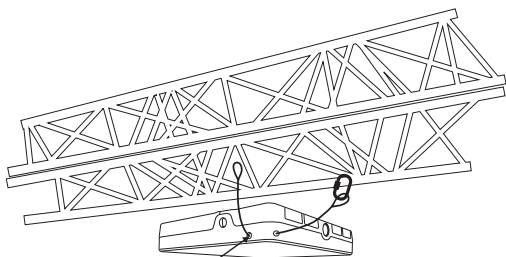

# USING MULTIPLE UNITE AP4

A maximum of **8 Unite AP4** can be connected with each other so that **32 channels** can be sent, received or sent and received – depending on the configuration.



To know which version of the Unite AP4 is compatible with your region, contact Televic Conference.

- › To synchronize the devices, connect the sync signal output of the first Unite AP4 to the sync signal input of the second Unite AP4. Use Cat 5e AWG 24/1 F/UTP cables or better. The assignment must be 1:1.
- › Connect the Sync signal output of the second Unite AP4 to the Sync signal input of the third Unite AP4, etc.
- › The first device acts as Sync Master so that each subsequent device receives a clock signal from the Sync Master. In this way the individual DECT channels of the devices are clocked. When using more than one Unite AP4 the synchronisation is absolutely necessary to ensure the operation.

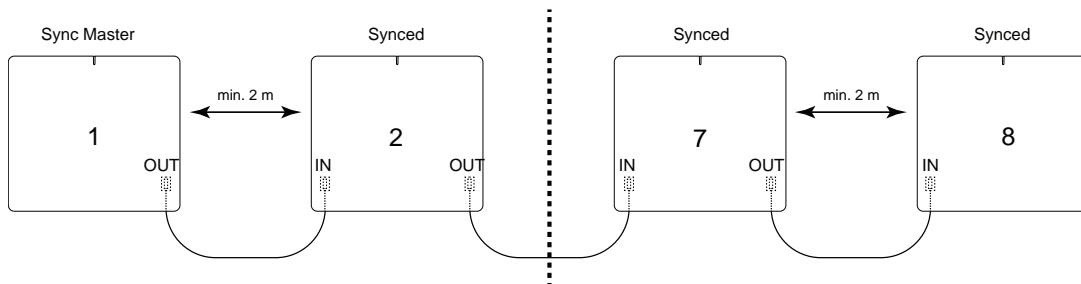

If several Unite AP4 are used in one room, a **minimum distance of 2 m** must be maintained between the individual units to avoid radio disturbances. The cable length between two devices must **not exceed 100 m**. The total length of all Sync cables used to connect the Unite AP4 devices to each other must **not exceed 700 m**.



For more information on how to configure and use the Unite AP4 Wireless Access Point, please refer to the [Unite Manager PC Software manual](#).

# MENU ITEMS

This chapter will explain the main menu items of the Unite TH handheld transmitter, Unite TP bodypack transmitter, and Unite RP and RP-T bodypack receivers, such as the "Audio", "Talkback", "Bluetooth®" and "System".

# GENERAL MENU ITEMS

- › Once you have turned on the Unite TP bodypack transmitter or Unite TH handheld transmitter and the Unite RP bodypack receiver, press the button 2 for approx. 2 seconds to access the menu.
- › Press the button 2 again to access the respective menu or submenu. Use this button also to save or confirm the desired setting.
- › Use the multifunction button 4 to scroll through the menu and to carry out various settings within the respective menu.

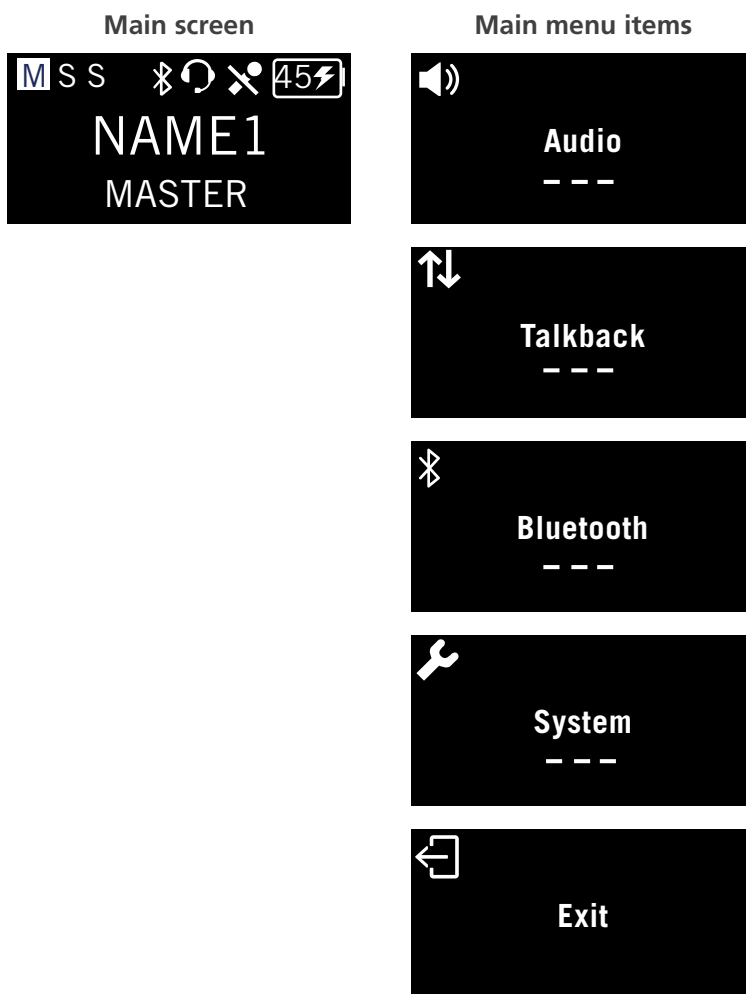

Depending on the device, up to 4 main menus with submenus are available:

- › Audio
- › Talkback

- > Bluetooth® (Unite TP and TH only)
- > System

The **dashes** at the bottom of the display in the individual menus show how many **submenus** or setting options are available in the respective menu.

If no setting is made or changed or if the button is not pressed, the display returns to the main screen after a few seconds.

An active function is indicated by a highlighted display.

**Example:** A transmitter is defined as "Master". As long as the function is not active, "Master" is displayed by a white "M" on a black background. When the "Master" function is active, the "M" is highlighted, i.e. the "M" turns black on a white background. Refer also to the illustration "Main screen" with an active "Master".

# AUDIO MAIN MENU

In the "Audio" main menu, the menus listed in the following table (menu path / level 2) with more submenus (menu path / level 3) are available for various audio settings.

1. Press the **⏻/Menu/Ok** button on the already switched on transmitter/receiver for approx. 2 seconds to access the menu.
2. Briefly press the button to access the "Audio" main menu.
3. Press the multifunction button to select the "Volume", "Microphone", "Quality", "Mute Button", "Line In Aux" or "Input Effects" submenu.
4. Briefly press the button to access the respective submenu.
5. Press the multifunction button to make settings in the respective submenu.
6. Briefly press the button to confirm the setting.

## Basic Audio Settings

Device	Menu path (Level 2)	Menu path (Level 3)	Adjustable parameters	Description
TP RP RP-T	Volume	HP initial level	0 to 24	HP = headphones <ul style="list-style-type: none"> <li>• When the device is turned on, the overall volume is defined.</li> <li>• When the device is restarted, the original volume is restored.</li> </ul>
TP	Volume	Mini XLR mic	0 to 12	Adjust the sensitivity (mic gain) of the mini XLR microphone jack.

Device	Menu path (Level 2)	Menu path (Level 3)	Adjustable parameters	Description
TP RP-T	Volume	Headset mic	0 to 12	Adjust the sensitivity (mic gain) of the headset microphone connected to the 3.5mm mini jack socket.
TP RP-T	Volume	Internal mic	0 to 12	Adjust the sensitivity (mic gain) of the internal microphone, if present.
TP	Volume	Line in	0 to 12	Adjust the input sensitivity of the mini jack input line (3.5mm).
TP RP-T	Volume	Sidetone	0 to 12	Adjust the volume when transmitting your own microphone signal on the headphone connector if you wish to hear your own voice.
TP RP-T	Microphone		<ul style="list-style-type: none"> <li>• Internal</li> <li>• Mini XLR</li> <li>• Headset</li> </ul>	Select the source of the microphone signal.
TP	Quality		<ul style="list-style-type: none"> <li>• HD</li> <li>• SD</li> </ul>	<ul style="list-style-type: none"> <li>• HD (high quality, 22.3 ms latency) - 50–14,000 Hz frequency range</li> <li>• SD (low quality, 18.3 ms latency) - 200–7,000 Hz frequency range</li> </ul>

Device	Menu path (Level 2)	Menu path (Level 3)	Adjustable parameters	Description
TP	Mute Button		<ul style="list-style-type: none"> <li>• Push</li> <li>• Toggle</li> </ul>	<ul style="list-style-type: none"> <li>• Push: the device's own microphone signal is muted for as long as the button is held down.</li> <li>• Toggle: the microphone is muted when pressed once and reactivated when pressed a second time.</li> </ul>
TP	Line In Aux		<ul style="list-style-type: none"> <li>• All</li> <li>• Master</li> <li>• Master &amp; Sub-Masters</li> </ul>	<ul style="list-style-type: none"> <li>• Establish which devices in the group can hear the signal available on the analogue line-in input.</li> </ul>

## Set Input Effects

The Unite system has a built-in DSP (Digital Signal Processor) for continuous processing of audio signals during operation.

In the "Audio" main menu, the "Input Effects" submenu contains various filter settings for processing audio signals.



Device	Menu path Level 2	Menu path Level 3	Menu path Level 4	Adjustable parameters	Description
TP RP-T	Input effects	ALC		<ul style="list-style-type: none"> <li>• Off</li> <li>• Low</li> <li>• High</li> </ul>	<p>ALC = Automatic Level Control.</p> <p>The device automatically adjusts microphone amplification and ensures a signal volume remains as consistent as possible to enhance speech intelligibility.</p> <p>Please note:</p> <ul style="list-style-type: none"> <li>• ALC is not available for the internal microphone</li> <li>• When ALC is active, the static settings for sensitivity of audio inputs in the "Audio/Volume" menu are disregarded and have no further influence upon signal processing.</li> </ul>
TP RP-T	Input effects	Low-cut filter		<ul style="list-style-type: none"> <li>• Off (50 Hz)</li> <li>• 80 Hz</li> <li>• 120 Hz</li> <li>• 180 Hz</li> <li>• 250 Hz</li> </ul>	<p>Equalizer setting or filter effect setting that cuts out all frequencies below a preset frequency.</p>

Device	Menu path Level 2	Menu path Level 3	Menu path Level 4	Adjustable parameters	Description
TP RP-T	Input effects	Equalizer		<ul style="list-style-type: none"> <li>• Off</li> <li>• Female</li> <li>• Male</li> </ul>	<p>Filter used to design the sound of the input audio signal.</p> <p>The settings options are "female" for female speakers and "male" for male speakers.</p> <p>The preset "High Noise" is for use in extremely noisy environments to ensure speech intelligibility despite loud background noise. This is particularly useful when the filters for background noise reduction (Noise Gate and Noise Canceler) no longer function on account of extreme background noise.</p>
TP RP-T	Input effects	Noise gate	State	<ul style="list-style-type: none"> <li>• Off</li> <li>• On</li> </ul>	<p>Filter effect in the category of dynamic processor. Suppresses low signal transmission.</p>

Device	Menu path Level 2	Menu path Level 3	Menu path Level 4	Adjustable parameters	Description
TP RP-T	Input effects	Noise gate	Threshold	-48 dB to -12 dB	Set the threshold value above which the background noise is muted. The lower the background noise, the lower the threshold value should be set.
TP RP-T	Input effects	Noise canceller		<ul style="list-style-type: none"> <li>• Off</li> <li>• Low</li> <li>• Mid</li> <li>• High</li> </ul>	<p>Eliminate noise in a smart, adaptive way. Works extremely well in case of continuous background interference.</p> <p>This filter is capable of "learning" to identify and eliminate noises, ensuring that only the voice is audible via the microphone input where possible.</p> <ul style="list-style-type: none"> <li>• Low: background noises are eliminated using lower volume.</li> <li>• Mid -&gt; high": background noises are eliminated using high volume.</li> </ul>

Device	Menu path Level 2	Menu path Level 3	Menu path Level 4	Adjustable parameters	Description
TP RP-T	Input effects	Compressor		<ul style="list-style-type: none"> <li>• Off</li> <li>• Low</li> <li>• High</li> <li>• Less pop noise</li> </ul>	<p>Restrict the signal's dynamic scope.</p> <ul style="list-style-type: none"> <li>• Low / High: "Low": degree of compression of the input signal.</li> <li>• Less pop noise: compression setting for additional reduction of unwanted sound.</li> </ul> <p>Regardless of the microphone used, it may be that plosive sounds (e.g. P, B, T, D, K) may cause distortion for the listener ("pop effect").</p>

Device	Menu path Level 2	Menu path Level 3	Menu path Level 4	Adjustable parameters	Description
TP	Input effects	Ducker		<ul style="list-style-type: none"> <li>• Off</li> <li>• Low</li> <li>• Mid</li> <li>• High</li> </ul>	<p>Ducking = giving specific automatic prominence to an audio signal by decreasing other signals.</p> <p>Use this effect when an external audio signal is transmitted as an analogue signal or via USB.</p> <p>Depending upon the level ("Low" or "High") of the setting, this external signal is then reduced as soon as the microphone is in use.</p>

# TALKBACK MAIN MENU

In the "Talkback" main menu, the menus listed in the following table (menu path / level 2) with further submenus (menu path / level 3) are available for various system settings.

1. Press the **⏻/Menu/Ok** button on the already switched on transmitter/receiver for approx. 2 seconds to access the menu.
2. Press the multifunction button to select the "Talkback" main menu.
3. Briefly press the **⏻/Menu/Ok** button to access the "Talkback" main menu.
4. Press the multifunction button to select the "Talk Button" or "Audio Routing".
5. Briefly press the **⏻/Menu/Ok** button to access the respective submenu.
6. Press the multifunction button to make settings in the respective submenu.
7. Briefly press the button **⏻/Menu/Ok** to confirm the setting.

Device	Menu path (Level 2)	Menu path (Level 3)	Adjustable parameters	Description
RP-T	Talk button		<ul style="list-style-type: none"> <li>• Push</li> <li>• Toggle</li> </ul>	<ul style="list-style-type: none"> <li>• Push: the relevant microphone is activated only for as long as the Talkback button is pressed.</li> <li>• Toggle: press the Talkback button once to switch on the internal or connected headset microphone. Press twice to deactivate the microphone.</li> </ul>

Device	Menu path (Level 2)	Menu path (Level 3)	Adjustable parameters	Description
TP	Audio routing	RP talkback	<ul style="list-style-type: none"> <li>• All</li> <li>• Master</li> <li>• Master &amp; Sub-Masters</li> </ul>	<p>Set the routing of talkback signals:</p> <ul style="list-style-type: none"> <li>• All: All devices in a specific group are able to listen in on talkback signals.</li> <li>• Master: only the Master device can hear the talkback signals.</li> <li>• Master &amp; Sub-Masters: only Master and Sub-Master can hear the talkback signals.</li> </ul>
TP	Audio routing	Sub-Masters	<ul style="list-style-type: none"> <li>• All</li> <li>• Master</li> <li>• Master &amp; Sub-Masters</li> </ul>	<p>This menu is used to set the routing of audio signals from devices configured as Sub-Master:</p> <ul style="list-style-type: none"> <li>• All: all devices in a specific group are able to listen in on the signals of Sub-Master devices.</li> <li>• Master: only the Master device can hear audio signals from the Sub-Master.</li> <li>• Master &amp; Sub-Masters: only the Master and all other Sub-Masters can hear audio signals from all Sub-Master devices in a group.</li> </ul>

# BLUETOOTH MAIN MENU

In the "Bluetooth" main menu, the menus listed in the following table (menu path / level 2) with further submenus (menu path / level 3) are available for various system settings.

1. Press the **⏻/Menu/Ok** button on the already switched on transmitter/receiver for approx. 2 seconds to access the menu.
2. Press the multifunction button to select the "Bluetooth" main menu.
3. Briefly press the **⏻/Menu/Ok** button to access the "Bluetooth" main menu.
4. Press the multifunction button to select the "State", "Connect" or "Pair" submenu.
5. Briefly press the **⏻/Menu/Ok** button to access the respective submenu.
6. Press the multifunction button to make settings in the respective submenu.
7. Briefly press the **⏻/Menu/Ok** button to confirm the setting.

Device	Menu path (Level 2)	Menu path (Level 3)	Adjustable parameters	Description
TP TH	State		<ul style="list-style-type: none"> <li>• Off</li> <li>• Headset</li> <li>• Phone / PC</li> </ul>	<p>Set Bluetooth® mode as the Bluetooth® interface can also be used both for playing in external audio material and playing back audio signals. This menu is used to</p> <ul style="list-style-type: none"> <li>• Off: Bluetooth® is deactivated.</li> <li>• Headset: select to connect an external headset and listen audio from other Unite devices.</li> <li>• Phone / PC: the transmitter serves as an external soundcard when connected to a smartphone, PC or Mac, and can receive audio from them.</li> </ul>



Device	Menu path (Level 2)	Menu path (Level 3)	Adjustable parameters	Description
TP TH	Connect			List of devices that have been successfully paired via a Bluetooth® connection.
TP TH	Pair			Select which device you want to pair in the list of all active devices in the immediate vicinity and follow the instructions on both devices.

# SYSTEM MAIN MENU

In the "System" main menu, the menus listed in the following table (menu path / level 2) with further submenus (menu path / level 3) are available for various system settings.

1. Press the **⏻/Menu/Ok** button on the already switched on transmitter/receiver for approx. 2 seconds to access the menu.
2. Press the multifunction button to select the "System" main menu.
3. Briefly press the **⏻/Menu/Ok** button to access the "System" main menu.
4. Press the multifunction button to select the "Channel Name", "Group ID", "Display", "Radio Power", "Device Mode", "Power Lockable", "Reset" or "Information" submenu.
5. Briefly press the **⏻/Menu/Ok** button to access the respective submenu.
6. Press the multifunction button to make settings in the respective submenu.
7. Briefly press the **⏻/Menu/Ok** button to confirm the setting.

Device	Menu path (Level 2)	Menu path (Level 3)	Adjustable parameters	Description
TP TH RP RP-T	Channel name		5 characters (upper & lower case, special characters and numbers)	Set the name of the channel name to avoid performing a channel search.
TP TH RP RP-T	Group ID		1 to 256	Set the group ID for devices (transmitter and receiver) that are used within a defined group. For more information, refer to the pairing section of this manual corresponding to your device.

Device	Menu path (Level 2)	Menu path (Level 3)	Adjustable parameters	Description
TP TH RP RP-T	Display	Brightness	10 to 100	Adjust the general brightness of the display.
TP TH RP RP-T	Display	Dimming level	Off to 100%	Set the value to which the brightness of the display is reduced after the dimming time has been reached.  When "Off" is selected, the display is completely switched off.
TP TH RP RP-T	Display	Dimming time	Off to 4 min	Select the time from which the selected dimming level value is applied to the brightness of the display.
TP TH	Radio power		<ul style="list-style-type: none"> <li>• Std</li> <li>• Mid</li> <li>• Low</li> </ul>	If you want to operate several transmitters in adjacent rooms simultaneously, adjust the transmission power of the transmitter to the receivers from standard to low.

Device	Menu path (Level 2)	Menu path (Level 3)	Adjustable parameters	Description
TP TH	Device mode		<ul style="list-style-type: none"> <li>• Master</li> <li>• Sub-Master</li> <li>• AP4 mic (Sub-master)</li> </ul>	<p>Switch the device mode of the transmitters.</p> <ul style="list-style-type: none"> <li>• Master: select this setting to turn the transmitter into the Master and pair it with up to 2 Sub-Masters.</li> <li>• Sub-Master: select this setting to turn the transmitter into a Sub-Master so that it can be paired with a Master.</li> <li>• AP4 mic: select this setting to pair the transmitter to a Unite AP4 Wireless Access Point (Master).</li> </ul> <p>For more information, see the section: "Using as a Sub-Master" section of your device.</p> <p><b>Important:</b> If you change and confirm this setting, the device switches off. Please switch it on again and wait until the device has reconfigured and the main screen is displayed.</p>
TP TH RP RP-T	Power lockable		<ul style="list-style-type: none"> <li>• Off</li> <li>• On</li> </ul>	<p>When this option is activated ("On"), it is not possible to switch the device off manually by holding down the On-off and Menu button.</p>
TP TH RP RP-T	Reset		Factory	<p>Resets the device to the factory settings. All pairing information will be deleted.</p>

Device	Menu path (Level 2)	Menu path (Level 3)	Adjustable parameters	Description
TP TH RP RP-T	Information	Battery		Battery information: <ul style="list-style-type: none"> <li>• Charge: remaining capacity</li> <li>• Charging: charging state</li> <li>• Average power: current power consumption</li> <li>• Temperature: battery temperature</li> <li>• Time to full or time to empty: display of time to full or empty</li> </ul>
TP TH RP RP-T	Information	Device		<ul style="list-style-type: none"> <li>• Firmware version: current firmware version</li> <li>• Firmware build: build number of the firmware</li> <li>• DECT ID: hardware address of the DECT interface</li> <li>• Production date</li> <li>• Serial number</li> <li>• Hardware version: built-in hardware version</li> <li>• Bluetooth® version: firmware version for Bluetooth®</li> </ul>



# SPECIAL FEATURES

This chapter will explain the special features the Unite system such as "Device Mode and Sub-Master Configuration", "Talkback" and "Number of Open Microphones".

# CHANNEL SEARCH

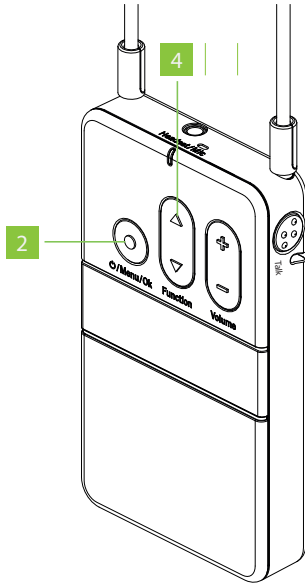
The "Channel" multifunction button (4) of the receiver (Unite RP and RP-T) is also used for channel search.



When you press  or  of the multifunction button, the device asks if a channel search should be carried out. Upon confirmation via the  button (2), the device will search for compatible wireless transmissions.

Both, transmitter and receiver, must have the same ID and encryption key. See the "Pairing" section of the Unite TP, or the "Pairing" section of the Unite TH transmitter to establish a connection between them.



By default, the transmitters and receivers are supplied with the group ID 256. A common factory-set audio encryption key, which cannot be changed, is used for the group ID range of 150 to 256. If several receivers are to be divided into different groups with an individual encryption, for each group an individual group ID between 1 and 149 can be assigned.

The scanning procedure is also a dynamic process as the automatic frequency management. This means that the devices scan continuously and do not stop this process independently.

Once the receiver has found one or more channels, press the  or  of the multifunction button (4) to select a channel.

Press the **⏻/Menu/Ok** button (2) to confirm the selected channel. The receiver then connects to the selected channel. This usually takes place within one second, however, due to various influencing factors it can also take several seconds.

**Example:** A high number of wireless connections in the immediate vicinity and/or too great a distance between transmitter and receiver.



# EXTERNAL INTERFACES

The transmitters Unite TP and Unite TH also offer interfaces with which audio signals can be received and/or played: analogue line-in, USB interface and Bluetooth®)

- › The **analogue line-in** (Unite TP only) is a 3.5mm 3-pole mini jack connector. Please note that a stereo signal in Unite is converted to a mono signal.
- › The **USB interface** (USB 2.0) with a type C connection port can play audio in and out simultaneously. It can also be used as a soundcard when combined with video conference or recording software and as an external soundcard when connected to a PC or Mac computer. Moreover, the device can be supplied with power and recharged via the USB port.
- › The **Bluetooth® interface** can also be used both for playing in external audio material and playing back audio signals. This depends upon configuration within the Bluetooth® menu (phone/PC; headset). You can also use a Bluetooth® headset. Please be aware that use of Bluetooth® in general will result in additional latency.



For more information about the connections, please refer to the datasheet of your device available on the [Televic Conference Knowledge Bas.](#)

# DEVICE MODE / SUB-MASTER CONFIGURATION

With Unite, the devices are basically divided into the categories "Master" (transmitter) and "Sub-Master" (receiver).

- › **The receivers Unite RP and RP-T** are automatically configured as Sub-Master.
- › **The transmitters Unite TP and TH** have the factory preset "Master" but can be configured as Sub-Masters to a virtual device mode (Menu: System/Device Mode). In this mode, a channel search must be carried out in order to connect the Sub-Master to a Master and the basic conditions for establishing a connection must be met (see the "Pairing" section of the Unite TP, or the "Pairing" section of the Unite TH for more information).

Up to three people can communicate with each other. The Unite RP-T receivers have a temporary Talkback channel, and the Unite transmitters have a **permanent** one. It means that if two Unite transmitters are configured as Sub-Masters, it won't be possible to use a Unite R-PT as a Sub-Master as the two channels will be permanently used. However, if only one transmitter is configured as a Sub-Master, or no transmitter is used at all, it will be possible to use an unlimited number of Unite RP-T devices.



Changing configuration between "Master" and "Sub-Master" takes a few minutes. This involves restarting the device.



In order to make use of this function, all Sub-Master devices must be within range of the Master.

# TALKBACK FUNCTION (RP-T ONLY)

The green Talkback button on the RP-T is used to activate the internal or externally connected microphone on the RP-T device.

With the Master device, you can define which device can receive the Talkback from the Unite RP-Ts in the groupe. To activate the Talkback option, go to Menu: Talkback > Audio Routing\* > RP Talkback.

Transmission of all audio signals within a group is always via the group's central Master (TP) (Broadcast; see fig.: Guided tours with talkback).

A talkback signal from an RP-T device is first sent to the Master (TP) device for transmission to the group. This principle is valid for all signals within a group, including all external signals (fig.: Sound transmission).

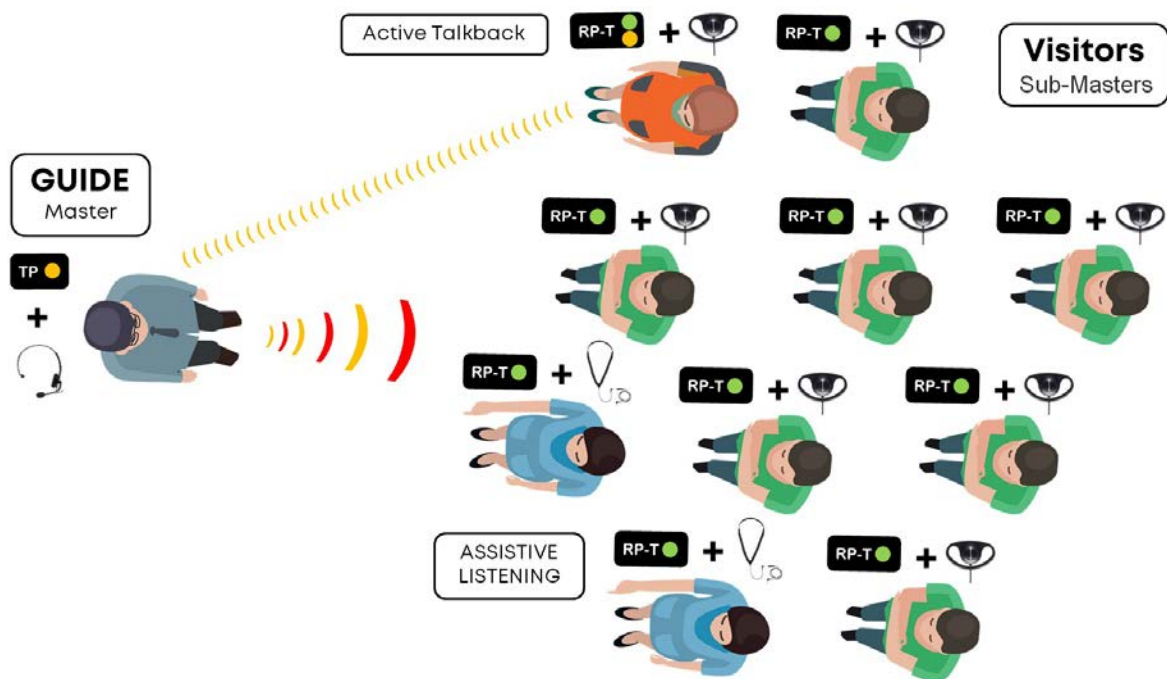

Figure 1-7 Guided tours with talkback

Figure 1-8

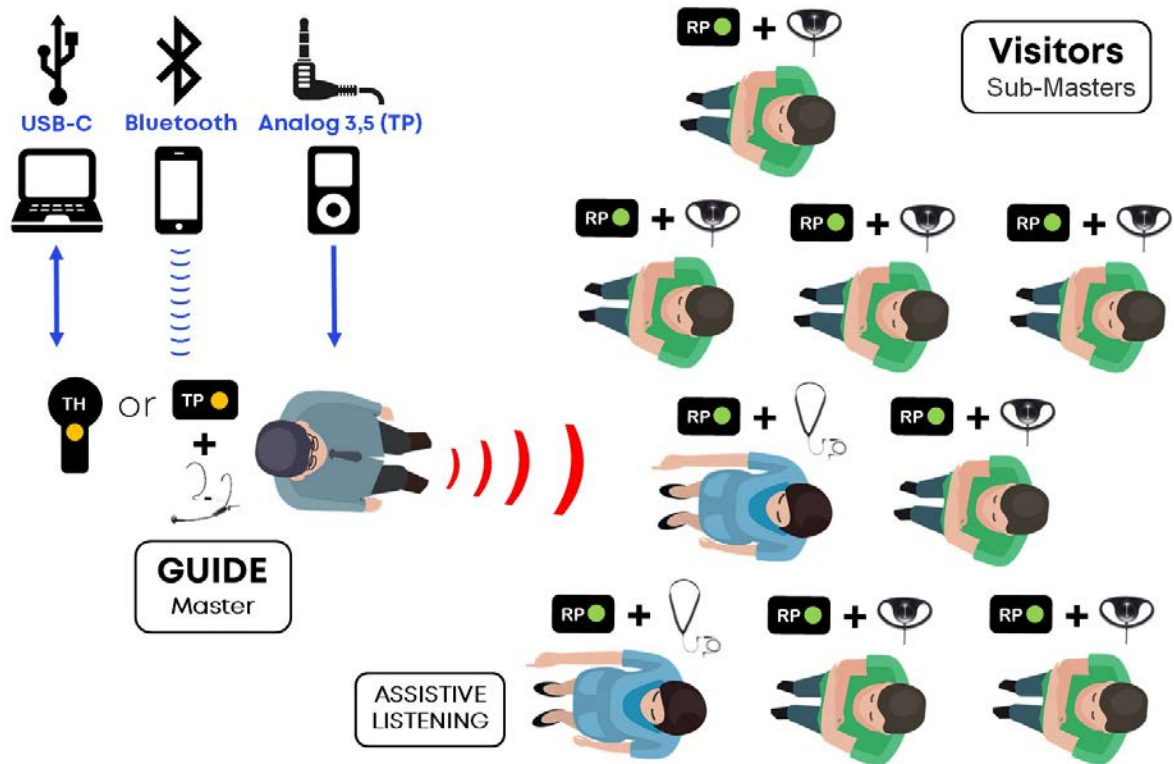

Figure 1-9 Sound transmission

# NUMBER OF OPEN MICROPHONES

Unite can route a maximum of **three simultaneously activated audio signals** within a group (NOM=3). This means that, in addition to a group's Master device, two talkback channels can be activated simultaneously.

Unite offers the option to set up whether there should be one or two talkback channels (Menu: Talkback / NOM Talkback\*).

When a Sub-Master is active in the group, the number of additional talkback channels that can be activated is reduced to one (fig.: Guided tours with two guides).

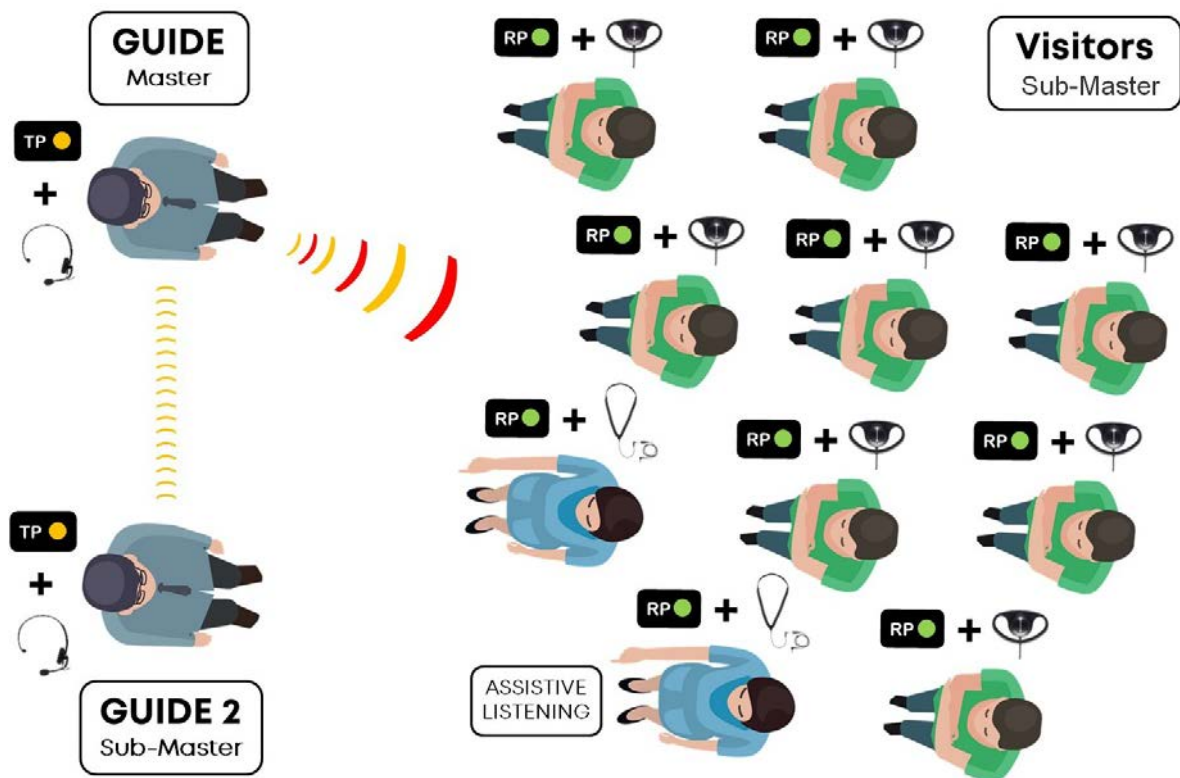

# SPECIAL FUNCTIONS

This chapter will explain the special functions of the Unite system such as "Button Lock", "Automatic Headset Recognition" and "Automatic Power Off".

# BUTTON LOCK

The button lock is a hidden function and is activated and deactivated as follows:

## Unite RP, RP-T, TP

- › Press and hold simultaneously one of the volume buttons and one of the "Function" buttons (RP; RP-T: "Channel" buttons) crosswise and for approx. 3 seconds.

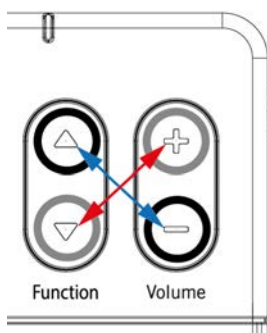

- › After activation/deactivation, the display "Button locked" / "Button unlocked" will appear.
- › As soon as the button lock is activated, you cannot use the button to enter the menu or to switch off the transmitter / receiver. This prevents switching off the device accidentally and unintentional changes to the menu settings.
- › The volume can still be increased or decreased by pressing the volume button.

## Unite TH

- › Press and hold simultaneously the Mute button and one of the "Function" buttons for approx. 3 seconds.

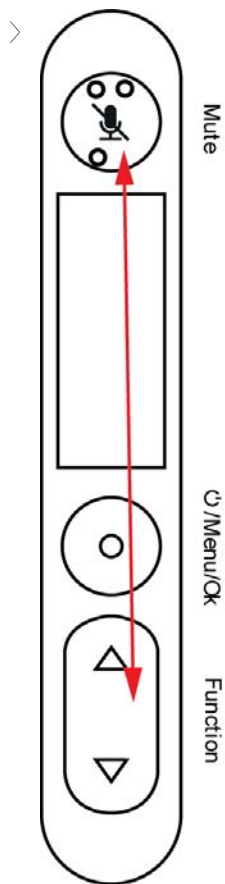

- > After activation/deactivation, the display "Button locked" / "Button unlocked" will appear.
- > As soon as the button lock is activated, you cannot use the button to enter the menu or to switch off the transmitter / receiver. This prevents switching off the device accidentally and unintentional changes to the menu settings.
- > The volume can still be increased or decreased by pressing the volume button.



# AUTOMATIC HEADSET RECOGNITION (TP, RP-T)

Unite has **automatic headset recognition** at the 3.5 mm jack socket.

As soon as a device is connected to this jack socket you will be asked whether a headset or headphones without microphone have been connected. The "Audio / Audio Source" menu is configured accordingly.

# AUTOMATIC POWER OFF

All Unite RP, RP-T, TP and TH devices configured by you as Sub-Master switch off automatically if no connection is made to a master device for at least 15 minutes (Display: "No RF").

# TROUBLESHOOTING

In this chapter, you will find help when problems occur while using the system.

# UNITE CHARGERS

## The charger shows no function.

- › Check whether the mains plug of the device is connected to the mains and whether the device is switched on.
- › Check the function of the power outlet used and replace the power cable if necessary to eliminate this as a source of error. The status indicator should light up red for approx. 10 seconds shortly after switching on, then green.
- › Check the fuse on the charger and replace it if necessary.

## When switched on, the status indicator lights up red for more than 10 seconds.

- › The power supply may have been interrupted during the last switch-on procedure. Check if the power plug of the device is securely connected and that the power supply is working properly. Wait until the status indicator lights up green again after a one-time self-test of about two minutes. The charging process of a bodypack device does not start automatically.
- › Check whether the charging contacts are dirty and clean them with a damp cloth if necessary. Make sure that the contacts in the charging slots are not bent. The devices should be inserted with a slight pressure. Insert the device again and observe the correct position. Try to charge the device in a different charging compartment. After some time, try to switch on the device and check the charging state on the display.

## Via "Discover Devices" the Unite Manager software cannot find a charger.

- › Make sure that the charger is switched on and connected to the PC via a DHCP-enabled router. The PC should also receive an IP address from the same address range as the router. In the Unite Manager software manual check under the "Configuration" > "Settings" menu item whether the correct network adapter has been selected for this connection and change it in the software if necessary.
- › If a firewall is activated on the PC or router, you must allow the connection to the charger via the ports 22, 161, 162 and 5353.

The charger has been switched to a static IP address and is no longer available / "Discover Devices" in the Unite Manager software generates the "SNMP Timeout" error message.

- › In order to reset the charger's network settings, use a paper clip to press the reset button next to the charger's network connection for 3 - 5 seconds. This resets the address assignment to DHCP mode.

The transfer of a new firmware for bodypack devices does not start automatically.

- › Remove the devices one by one from the charging slots and check whether the current firmware version is already on the device. Check the menu under "System" > "Information" > "Device". The update process is automatically activated upon re-insertion into the charger and takes up to 10 minutes to complete.

A bodypack device does not show any function / cannot be switched on.

- › Check whether the battery is completely discharged.
- › If the charging contacts are dirty, clean them with a damp cloth if necessary.
- › Check whether the contacts in the charging slots are bent and try to charge the device in another charging compartment or test it using the USB interface (next to the network socket).
- › If you have any problems, please contact your service representative.

The status LED of the charger illuminates green before the charger is fully operational. After a reboot it is possible that the number of slots or other data are not yet completed when the charger is read too quickly by the Unite Manager PC software.

- › When the green status LED of the charger shows the ready-to-operation status after a restart, please wait approx. 15 seconds, before you read the charger again via the Unite Manager PC software (Discover Devices / Refresh data).

The DHCP IP address of a charger or Unite AP4 is not automatically changed, when the router or subnet is replaced.

- › Reboot the charger or Unite AP4 when changing the router and/or the subnet to receive a new DHCP IP address on the new network.

In rare cases it is possible that a mobile device (transmitter or receiver) is not detected in the charger. As a result, settings are not transferred and the device is not displayed in the Unite Manager PC software.

- › Remove the device from the charger and reinsert it.
- › Make sure that the charging contacts on the mobile device or in the charger are clean. If necessary, use a lint-free cloth to clean them. Make sure that you switch off the charger before starting to clean the contacts.

# UNITE BODYPACK RECEIVERS

The transfer of a new firmware for bodypack devices does not start automatically.

- › Remove the devices one by one from the charging slots and check whether the current firmware version is already on the device. Check the menu under "System" > "Information" > "Device". The update process is automatically activated upon re-insertion into the charger and takes up to 10 minutes to complete.

A bodypack device does not show any function / cannot be switched on.

- › Check whether the battery is completely discharged.
- › If the charging contacts are dirty, clean them with a damp cloth if necessary.
- › Check whether the contacts in the charging slots are bent and try to charge the device in another charging compartment or test it using the USB interface (next to the network socket).
- › If you have any problems, please contact your service representative.

The battery status is not displayed correctly when a mobile device is turned on.

- › It may take up to 1 minute until the battery status is displayed correctly after the device has been turned on.

If you try to connect a Unite TP/TH in the "AP4 Mic (SubM)" to an already occupied Full Duplex channel of a Unite AP4, the mobile device will show "Channel occupied" in the display. If the device is then turned off and on again, the channel list may be incomplete or incorrect.

- › Turn the Unite TP/TH off and on again. If you still cannot receive a complete list, enter the name of a free channel manually via the menu "System" > "Channel Name".

In the Broadcast HD mode, the mobile receivers display "Connecting..." permanently in rare cases, although they should connect.

- › Please check:
  - › if the selected channel name works with other receivers.
  - › if the pairing information conforms with the Unite AP4 in use.
- › On the mobile receiver, use the channel list to select the channel again or restart the mobile receiver

The battery state is not displayed correctly on mobile devices (transmitter and receiver).

- › Restart the device.

In rare cases it is possible that a mobile receiver displays a channel name, but does not play audio.

- › On the mobile receiver, use the channel list to select the channel again or restart the mobile receiver.

In rare cases it is possible that a mobile device (transmitter or receiver) does not show the contents of the display correctly.

- › Restart the device.

In rare cases it is possible that a mobile device (transmitter or receiver) is not detected in the charger. As a result, settings are not transferred and the device is not displayed in the Unite Manager PC software.

- › Remove the device from the charger and reinsert it.
- › Make sure that the charging contacts on the mobile device or in the charger are clean. If necessary, use a lint-free cloth to clean them. Make sure that you switch off the charger before starting to clean the contacts.

No USB audio via TP/TH in the master mode on a PC/Mac.



- › When using a USB audio connection of a TP/TH in the master mode with a PC or Mac, the USB audio connection will not be established if the TP was not switched on before USB was connected. In this case briefly disconnect the USB connection and reconnect the TP, which is now switched on, via USB. To avoid this error, please switch on the TP/TH in the master mode before using the USB audio connection.

Noise interference via USB interface on a PC/Mac when using a TP/TH in the sub-master mode or an RP-T with talkback.

- › When using a USB audio connection of a TP/TH in the sub-master mode or an RP-T with talkback with a PC or Mac, it may very rarely happen that the USB audio connection generates noise if the connection to a master TP/TH is lost due to e.g. a great distance between the devices. In this case, briefly disconnect and reconnect the USB connection of the TP/TH in the sub-master mode or briefly interrupt the talkback connection of an RP-T by pressing the "Talk" button twice. To avoid this error, please make sure that there is a constant connection to the master TP/TH when transmitting USB audio via this path.

The status LED of one or more devices in the charger is quickly flashing red.

- › The device has detected a charging error. Please remove the device and switch it on briefly. Please check whether the battery indicator shows a charge of >0%. Insert the device in question into the charger again for at least four hours. Should the error occur again with the same device, please contact the customer service known to you.

The battery percentage is not consistent with the actual usage of the system.

- › This bug was fixed with the V0144 firmware version for mobile devices.

The battery capacity is lowered after the device has been used for a long time.

- › It is possible to have the battery replaced by our service personnel. For this purpose there has been added a new menu item "Reset Battery", which has to be activated by them in order to reset the battery capacity estimation algorithm.

The firmware update is not finished or takes a very long time.

- › When updating portable devices with firmware versions older than V0082, the General Setting Talkback "Request" could prevent the update process from being completed. Please set the Talkback setting to On or Off before updating devices with versions prior to V0082 using chargers prior to V0029.

# UNITE AP4

No connection can be created from / to an AP4 in Dante<sup>®</sup> Controller.

- › Please make sure that the other device (i.e. the Dante<sup>®</sup> Virtual Soundcard) is set to 48 kHz and, if necessary reboot both devices and restart the Dante<sup>®</sup> Controller Software. If the AP4 was in use in a different network before, this may be necessary in order to deactivate previous routings.

The AP4 is not visible in Dante<sup>®</sup> Controller.

- › Please verify, that the AP4 is in the same IP Subnetwork as the PC running Dante<sup>®</sup> Controller.
- › Please be aware that the Dante<sup>®</sup> IP address cannot be viewed or changed via Unite Manager, it must be changed in the Dante<sup>®</sup> Controller software. Once configured as static IP address, it cannot be changed back to DHCP with the reset button on the back of the device.

The GrandMaster is changing between different devices.

- › Please make sure that there is only a single DHCP server active in the network. If no preferred Master is set, define the AP4 as GrandMaster that is also the Sync Master in Unite Manager.

There is a connection, but the audio signal is very low or not there at all.

- › Please check in Unite Manager, if the Input and output levels are set correctly and mute is disabled for each channel.

The Dante<sup>®</sup> connection causes audio problems that are not reproducible with analogue In- or Outputs.

- › Please make sure that there is only a single DHCP server active in the network. If a managed switch is used, it can be necessary to configure it for forwarding of multicast traffic. If necessary, IGMP snooping has to be disabled or an IP address has to be configured as IGMP querier in order to forward multicast traffic.

No further target devices can be connected to a single AP4.

- › There can be only up to two audio data streams per AP4. For more routing options all channels have to be relayed to a Dante<sup>®</sup>-enabled mixer first.

The status LED of the Unite AP4 will illuminate green before the device is fully operational. After a reboot it is possible that the device data is not yet completed when the device is read too quickly by the Unite Manager PC software.

- › When the green status LED of the Unite AP4 shows the ready-to-operation status after a restart, please wait approx. 15 seconds, before you read the device again via the Unite Manager PC software (Discover Devices / Refresh data).

The DHCP IP address of a charger or Unite AP4 is not automatically changed, when the router or subnet is replaced.

- › Reboot the charger or Unite AP4 when changing the router and/or the subnet to receive a new DHCP IP address on the new network.

In rare cases it is possible that in the Full Duplex HD mode one channel of the used Unite AP4 is displayed as occupied, although this is not the case.

- › Either restart the Unite AP4 via the Unite Manager PC software or turn the Unite AP4 manually off and on again. Please note that when the Unite AP4 is restarted, all other connected mobile devices must reconnect in the "AP4 Mic (SubM)" mode. In rare cases the device must be restarted so that it can reconnect.

Additional problems not listed here.

- › Please refer to the [Audinate Website](#) in the [Support section](#) for further troubleshooting.

# televic

## TELEVIC CONFERENCE

Leo Bekaertlaan 1

8870 Izegem

Belgium

+32 51 30 30 45

GET IN TOUCH

f in 