 Living Independently Group, Inc. <small>Caring. Value. Independence.</small>		PRODUCT MANUAL	
TITLE:	ZIGBEE POWER MODULE QC101100		
REVISION:	1.0	DATE:	

Product Description

The Zigbee Power Module provides the Zigbee routing services needed to form a full Zigbee Mesh Network. It also functions as a power switch, and can sense when a load is applied (teapot function). It has a battery backup providing at least 2 hours of standby power, to allow the Zigbee network to continue to operate during power outages.

Features

- Zigbee Router functionality for robust Mesh Networking
- Multifunction button for
 - o manual relay activation
 - o zigbee configuration control
 - o button's backlight LED indicates zigbee activity
- Bicolor status LED
 - o load status
 - o backup battery status
- Battery engage switch for storage/transportation
- 3-prong grounded connection
- buzzer to warn of power failure

Installation

- Please familiarize yourself with the concepts of Zigbee Networking with the "Understanding Sensor Networking" paper.
- The network Coordinator must be set up before any Routers including this Power Module.
- While holding down the Multifunction button (clear plastic button on top), use a pen to activate the battery with the battery engage button. The unit will start beeping. (Holding down the Multifunction button clears out the Associated Device table so the module is ready for a new network configuration)
- Now you can plug the module into an appropriate AC outlet. The unit will take a few seconds to calibrate and join the Zigbee network.
- Orient the antenna the same direction as the Coordinator antenna (usually this is vertical).
- You may plug in whatever load you want to control/monitor, within the power limits described in this manual.

Commissioning

- Once all routers are installed then you will start adding any sensors (such as the Motion Sensor).
- Use the Multifunction button to control how the sensors "Join" the network. You will notice that when you press the button the blue LED will alternately flash, or stop flashing. When the LED is flashing, then sensors are **prohibited** from

joining this router. This mode will automatically expire after 45 minutes or so. This way you can control the initial configuration of a network, forcing nearby sensors to join the closer router. Note that in normal operation, sensors may “jump” from one router to another – that is the nature of Mesh networking.

Operation

In normal operation the user need not interact with the Power Module, as it is normally controlled remotely via Zigbee.

If the unit is unplugged or the power goes out, the unit will emit a short beep every few seconds and the status LED will flash red.

The unit contains a rechargeable battery which needs no maintenance. It will charge automatically when the unit is plugged in. The status LED will flash green when it is charging, and will glow green steadily when it is fully charged. When the battery is fully charged the Zigbee Router will operate for over 2 hours during a power failure. The battery takes approximately 8 hours to fully charge from a completely discharged state.

Warning

This device is intended for indoor use only. Do not enclose or cover this device. Use in a well-ventilated, open area. Do not use this device at temperatures higher than 104° F (40° C). Do not use in wet or damp conditions. Do not use this product with any electrical device that exceeds the maximum rating as stated in the Technical Specs section of this manual.

Technical Specs

Voltage	90-125 volts, 60Hz
Switching power	1150 watts resistive 15 amps, 750 watts incandescent
Motor switching	½ HP
Communication	IEEE 802.15.4 Zigbee, 2.4GHz ISM band, +10dBi max output
Typical range indoor	100 feet (30m)
Zigbee profile	HA (Home Automation) SLC (switched load control)

Zigbee Profile

sample profile for a ZigbeePower device

```
<ZigbeeDevice>
  short addr: 0x1
  IEEE addr: 0x1d400000100021
  type bits: 0x1
  freq bits: 0x8
  caps bits: 0xe
  servermask bits: 0x0
  complex desc. avail: 0x1
  user desc. avail: 0x1
  APS flags: 0x0
  mfg code: 0x1038
  bufsiz: : 0x50
  xfersiz: 0x0
  powermode: 0x0
  powersources: 0x3
  powersource: 0x1
  powerlevel: 0xc
  user descr: QC101100 v0.5
  language: None
  charset: None
  mfg name:
  model:
  serial#:
  device URL:
  endpoints: {2:
<ZigbeeDescriptor>
  profile: 0x104
  device: 0x9
  version: 0x0
  inClusters: [0, 3]
  outClusters: [0, 1, 3, 6, 1026]
  flags: 0x0
</ZigbeeDescriptor>
, 20: None}
  registered? 0
  last contact 2008-01-16 16:37:05.294272
  last LQI 100
  avg LQI 133.366724
  missed pkts 2
  attributes: {'mains voltage': 116.40000000000001,
               'battery voltage': 4.1000000000000005,
               'switch': 'off',
               'temperature': 24.75}
</ZigbeeDevice>
```

Block diagram

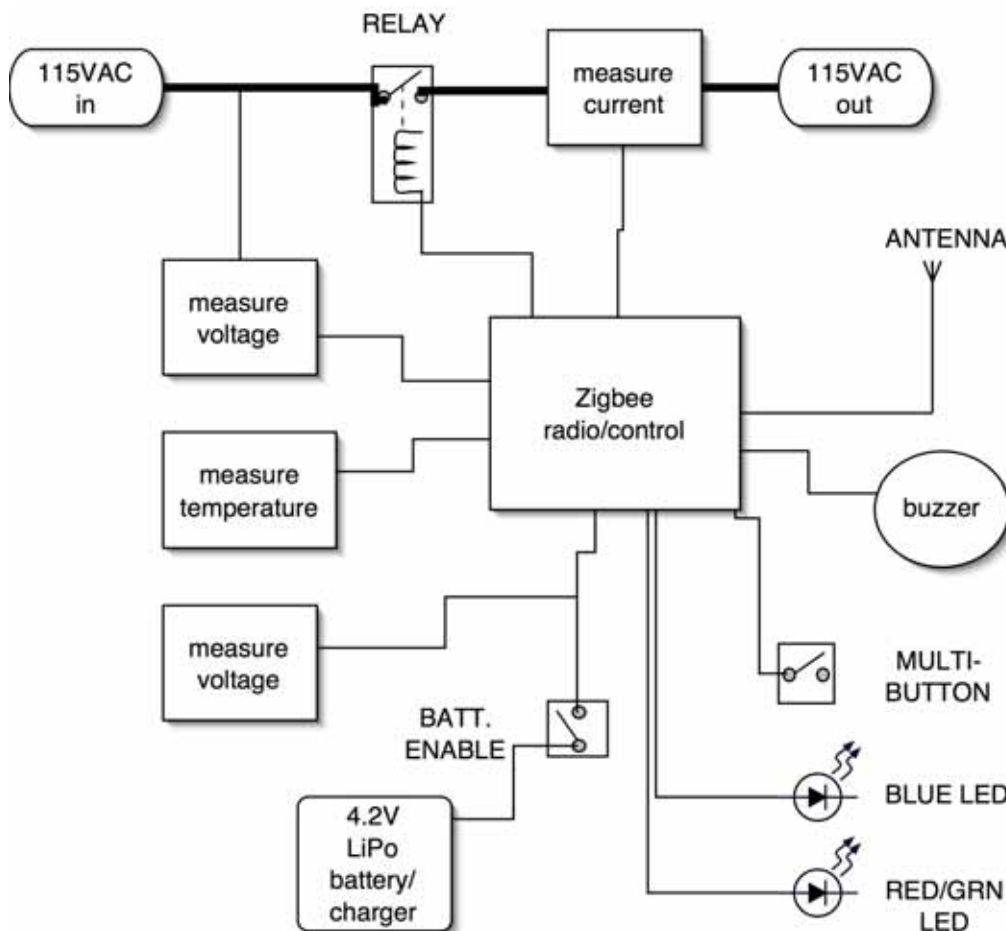

Approvals

INSTRUCTIONS TO THE USER:

The user is cautioned that changes and modifications made to the equipment without the approval of manufacturer could void the user's authority to operate this equipment.

This equipment has been tested and found to comply with the limits for a class B digital device, pursuant to part 15 of the FCC Rules. These limits are designed to provide reasonable protection against harmful interference in a residential installation. This equipment generates, uses, and can radiate radio frequency energy and if not installed and used in accordance with the instructions, may cause harmful interference to radio communications. However, there is no guarantee that interferences will not occur in a particular installation. If this equipment does cause harmful interference to radio or television reception, which can be determined by turning the equipment off and on, the user is encouraged to try to correct the interference by one or more of the following measures:

- Reorient or relocate the receiving antenna.
- Increase the separation between the equipment and receiver.
- Connect the equipment into an outlet on a circuit different from that to which the receiver is connected.
- Consult the dealer or an experienced radio/TV technician for help.

CE directive 93/68/EEC, EMC directive 2004/108/EEC, LV directive 73/23/EEC
This class B digital apparatus complies with Canadian ICES-003

The term "IC:" before the certification/registration number only signifies that the Industry Canada technical specifications were met.

Operation is subject to the following two conditions: (1) this device may not cause interference, and (2) this device must accept any interference, including interference that may cause undesired operation of the device.

FCC NOTE:

This equipment has been tested and found to comply with the limits for a Class B digital device, pursuant to Part 15 of the FCC Rules. These limits are designed to provide reasonable protection against harmful interference in a residential installation. This equipment generates, uses and can radiate radio frequency energy and, if not installed and used in accordance with the instructions, may cause harmful interference to radio communications. However, there is no guarantee that interference will not occur in a particular installation. If this equipment does cause harmful interference to radio or television reception, which can be determined by turning the equipment off and on, the user is encouraged to try to correct the interference by one or more of the following measures:

- Reorient or relocate the receiving antenna
- Increase the separation between the equipment and receiver.
- Connect the equipment into an outlet on a circuit different from that to which the receiver is connected.
- Consult the dealer or an experienced radio/TV technician for help.

This device complies with Part 15 of the FCC Rules. Operation is subject to the following two conditions: (1) this device may not cause harmful interference, and (2) this device must accept any interference received, including interference that may cause undesired operation.

The manufacturer is not responsible for any radio or TV interference caused by unauthorized modifications to this equipment. Such modifications could void the user's authority to operate the equipment.

The antenna used for this transmitter must be installed to provide a separation distance of at least 20 cm from all persons and must not be co-located or operated in conjunction with any other antenna or transmitter

IC NOTE:

This device complies with Industry Canada licence-exempt RSS standard(s): Operation is subject to the following two conditions: (1) this device may not cause interference, and (2) this device must accept any interference, including interference that may cause undesired operation of the device."

This Class [B] digital apparatus complies with Canadian ICES-003.