 Living Independently Group, Inc. <small>Caring. Value. Independence.</small>		PRODUCT MANUAL	
TITLE:	ZIGBEE PIR QC101000		
REVISION:	1.0	DATE:	1/19/08

Product Description

The Zigbee PIR is an enhanced wireless motion sensor.

Features

- Sensitive PIR motion detector
- Accurate temperature sensor
- Daylight illuminance sensor
- User pushbutton built in to LED indicator for easy configuration.

Installation

- Please familiarize yourself with the concepts of Zigbee Networking with the “Understanding Sensor Networking” paper.
- The network Coordinator and any Routers must be set up before setting up this sensor.
- Securely attach the wall bracket using the supplied screws or tape. See the Quiet Care installation manual for system installation details concerning placement.
- For optimum range the sensor should not be used on metal doors, metal doorframes, metalized mirrors, or other metal objects.
- Expose the battery compartment by twisting apart the enclosure in the direction of the arrow. Locate the battery activation tab (clear plastic tab) and pull it out, allowing the battery to make contact. The green LED should flash briefly indicating successful power up.
- Replace the battery cover and place sensor in bracket positions appropriately for the desired coverage area.

Commissioning

- Once powered up the sensor will automatically join the Zigbee network.

Operation

In normal operation the user need not interact with the motion detector, as it is normally controlled remotely via Zigbee.

Changing batteries

The device uses standard AA alkaline batteries. Always replace both batteries at the same time. Always use fresh new batteries of the same brand. The battery compartment is exposed by twisting the enclosure in the direction of the arrow about 1/8 turn, and then pulling apart. Make note of the polarity markings in the battery enclosure.

Mounting template

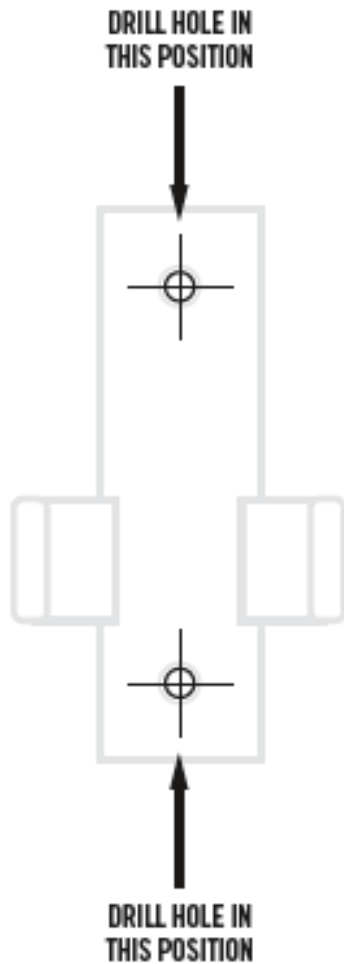

Technical Specs

Voltage	2xAA 1.5V alkaline battery
PIR	Long range (20 feet at 20°C) motion sensor with false trigger reduction
Temperature range	-10°C to 40°C
Enclosure	High impact ABS plastic
Communication	IEEE 802.15.4 Zigbee, 2.4GHz ISM band, +0dBi max output
Typical range indoor	30 feet (10m)
Typical range outdoor	300 feet (100m)
Zigbee profile	HA (Home Automation) OS (occupancy sensor)

Zigbee Profile

sample profile for a ZigbeePIR device
 <ZigbeeDevice>

```
short addr: 0x7972
IEEE addr: 0x1d400000000022
type bits: 0x2
freq bits: 0x8
caps bits: 0x0
servermask bits: 0x0
complex desc. avail: 0x1
user desc. avail: 0x1
APS flags: 0x0
mfg code: 0x1038
bufsiz: : 0x50
xfersiz: 0x0
powermode: 0x1
powersources: 0x4
powersource: 0x4
powerlevel: 0xc
user descr: QC101000 v0.51
language: None
charset: None
mfg name:
model:
serial#:
device URL:
endpoints: {2:
<ZigbeeDescriptor>
  profile: 0x104
  device: 0x107
  version: 0x0
  inClusters: [0, 3]
  outClusters: [1, 6, 1024, 1026, 1030]
  flags: 0x0
</ZigbeeDescriptor>
, 20: None}
  registered? 0
  last contact 2008-01-16 16:44:13.676605
  last LQI 120
  avg LQI 121.260521
  missed pkts 5
  attributes: {'battery voltage': 2.4000000000000004,
               'temperature': 24.75,
               'illuminance': 103,
               'switch': 'off',
               'occupiedAccum': 29,
               'occupied': False}
</ZigbeeDevice>
```

Block diagram

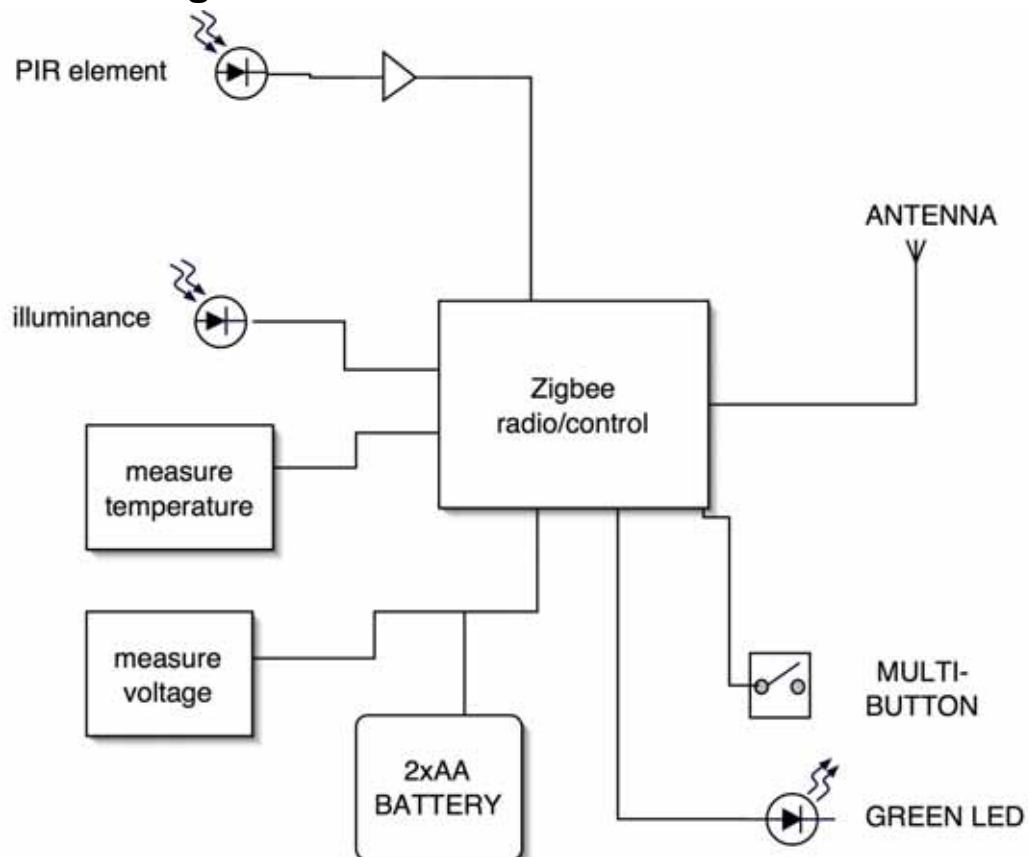

Approvals

INSTRUCTIONS TO THE USER:

The user is cautioned that changes and modifications made to the equipment without the approval of manufacturer could void the user's authority to operate this equipment.

This equipment has been tested and found to comply with the limits for a class B digital device, pursuant to part 15 of the FCC Rules. These limits are designed to provide reasonable protection against harmful interference in a residential installation. This equipment generates, uses, and can radiate radio frequency energy and if not installed and used in accordance with the instructions, may cause harmful interference to radio communications. However, there is no guarantee that interferences will not occur in a particular installation. If this equipment does cause harmful interference to radio or television reception, which can be determined by turning the equipment off and on, the user is encouraged to try to correct the interference by one or more of the following measures:

- Reorient or relocate the receiving antenna.
- Increase the separation between the equipment and receiver.
- Connect the equipment into an outlet on a circuit different from that to which the receiver is connected.
- Consult the dealer or an experienced radio/TV technician for help.

CE directive 93/68/EEC, EMC directive 2004/108/EEC, LVD directive 73/23/EEC

This class B digital apparatus complies with Canadian ICES-003

The term "IC:" before the certification/registration number only signifies that the Industry Canada technical specifications were met.

Operation is subject to the following two conditions: (1) this device may not cause interference, and (2) this device must accept any interference, including interference that may cause undesired operation of the device.

FCC NOTE:

This equipment has been tested and found to comply with the limits for a Class B digital device, pursuant to Part 15 of the FCC Rules. These limits are designed to provide reasonable protection against harmful interference in a residential installation. This equipment generates, uses and can radiate radio frequency energy and, if not installed and used in accordance with the instructions, may cause harmful interference to radio communications. However, there is no guarantee that interference will not occur in a particular installation. If this equipment does cause harmful interference to radio or television reception, which can be determined by turning the equipment off and on, the user is encouraged to try to correct the interference by one or more of the following measures:

- Reorient or relocate the receiving antenna
- Increase the separation between the equipment and receiver.
- Connect the equipment into an outlet on a circuit different from that to which the receiver is connected.
- Consult the dealer or an experienced radio/TV technician for help.

This device complies with Part 15 of the FCC Rules. Operation is subject to the following two conditions: (1) this device may not cause harmful interference, and (2) this device must accept any interference received, including interference that may cause undesired operation.

The manufacturer is not responsible for any radio or TV interference caused by unauthorized modifications to this equipment. Such modifications could void the user's authority to operate the equipment.

The antenna used for this transmitter must be installed to provide a separation distance of at least 20 cm from all persons and must not be co-located or operated in conjunction with any other antenna or transmitter

IC NOTE:

This device complies with Industry Canada licence-exempt RSS standard(s): Operation is subject to the following two conditions: (1) this device may not cause interference, and (2) this device must accept any interference, including interference that may cause undesired operation of the device."

This Class [B] digital apparatus complies with Canadian ICES-003.