

FCC Test Report

Product Name	Tablet PC
Model No	TU10MK, TF10MK1, Ty10MKx(y=0~9, A~Z or blank or “-”, x=0~9, A~Z or blank or “-”)
FCC ID.	WL6-TU1MT63MK1

Applicant	ELITEGROUP COMPUTER SYSTEMS CO., LTD
Address	No.239, Sec. 2, Ti Ding Blvd., Taipei, Taiwan

Date of Receipt	Dec. 15, 2017
Issue Date	Jan. 26, 2018
Report No.	17C0206R-RFUSP26V00
Report Version	V1.0



The test results relate only to the samples tested.

The test results shown in the test report are traceable to the national/international standard through the calibration report of the equipment and evaluated measurement uncertainty herein.

This report must not be used to claim product endorsement by TAF or any agency of the government.

The test report shall not be reproduced without the written approval of DEKRA Testing and Certification Co., Ltd.

Test Report

Issue Date: Jan. 26, 2018

Report No.: 17C0206R-RFUSP26V00



Product Name	Tablet PC
Applicant	ELITEGROUP COMPUTER SYSTEMS CO., LTD
Address	No.239, Sec. 2, Ti Ding Blvd., Taipei, Taiwan
Manufacturer	ELITEGROUP COMPUTER SYSTEMS CO., LTD
Model No.	TU10MK, TF10MK1, Ty10MKx(y=0~9, A~Z or blank or "-", x=0~9, A~Z or blank or "-")
FCC ID.	WL6-TU1MT63MK1
EUT Rated Voltage	AC 100-240V, 50-60Hz or DC 3.7V(Power by battery)
EUT Test Voltage	AC 120V/60Hz
Trade Name	ECS ELITEGROUP
Applicable Standard	FCC CFR Title 47 Part 15 Subpart C: 2016 ANSI C63.4: 2014, ANSI C63.10: 2013 KDB 558074 D01 DTS Meas Guidance v04
Test Result	Complied

Documented By : Jinn Chen
(Senior Adm. Specialist / Jinn Chen)

Tested By : Steven Tsai
(Assistant Engineer / Steven Tsai)

Approved By : Vincent Lin
(Director / Vincent Lin)

TABLE OF CONTENTS

Description	Page
1. GENERAL INFORMATION	5
1.1. EUT Description.....	5
1.2. Operational Description	7
1.3. Tested System Details.....	8
1.4. Configuration of Tested System	8
1.5. EUT Exercise Software	9
1.6. Test Facility	10
1.7. List of Test Item and Equipment	11
2. Conducted Emission.....	12
2.1. Test Setup	12
2.2. Limits	12
2.3. Test Procedure	12
2.4. Uncertainty	12
2.5. Test Result of Conducted Emission.....	13
3. Peak Power Output	15
3.1. Test Setup	15
3.2. Limits	15
3.3. Test Procedure	15
3.4. Uncertainty	15
3.5. Test Result of Peak Power Output.....	16
4. Radiated Emission.....	20
4.1. Test Setup	20
4.2. Limits	21
4.3. Test Procedure	22
4.4. Uncertainty	23
4.5. Test Result of Radiated Emission.....	24
5. RF antenna conducted test.....	40
5.1. Test Setup	40
5.2. Limits	40
5.3. Test Procedure	40
5.4. Uncertainty	40
5.5. Test Result of RF antenna conducted test.....	41
6. Band Edge	45
6.1. Test Setup	45
6.2. Limits	46
6.3. Test Procedure	46
6.4. Uncertainty	47
6.5. Test Result of Band Edge	48
7. 6dB Bandwidth	64
7.1. Test Setup	64
7.2. Limits	64

7.3.	Test Procedure	64
7.4.	Uncertainty	64
7.5.	Test Result of 6dB Bandwidth.....	65
8.	Power Density	73
8.1.	Test Setup	73
8.2.	Limits	73
8.3.	Test Procedure	73
8.4.	Uncertainty	73
8.5.	Test Result of Power Density	74
9.	Duty Cycle	82
9.1.	Test Setup	82
9.2.	Test Procedure	82
9.3.	Uncertainty	82
9.4.	Test Result of Duty Cycle.....	83
10.	EMI Reduction Method During Compliance Testing	86

Attachment 1: EUT Test Photographs

Attachment 2: EUT Detailed Photographs

1. GENERAL INFORMATION

1.1. EUT Description

Product Name	Tablet PC
Trade Name	ECS ELITEGROUP
Model No.	TU10MK, TF10MK1, Ty10MKx(y=0~9, A~Z or blank or “-”, x=0~9, A~Z or blank or “-”)
FCC ID.	WL6-TU1MT63MK1
Frequency Range	2412-2462MHz for 802.11b/g/n-20BW, 2422-2452MHz for 802.11n-40BW
Number of Channels	802.11b/g/n-20MHz: 11, n-40MHz: 7
Data Speed	802.11b: 1-11Mbps, 802.11g: 6-54Mbps, 802.11n: up to 150Mbps
Channel separation	802.11b/g/n: 5 MHz
Type of Modulation	802.11b:DSSS (DBPSK, DQPSK, CCK) 802.11g/n:OFDM (BPSK, QPSK, 16QAM, 64QAM)
Antenna Type	PIFA Antenna
Antenna Gain	Refer to the table “Antenna List”
Channel Control	Auto
Power Adapter	MFR: Asian, M/N:WB-10E05R Input:100-240V~50-60Hz, 0.4A Output:5V $\overline{\text{---}}$, 2A Cable Out Non-shielded, 1.5m

Antenna List

No.	Manufacturer	Part No.	Antenna Type	Peak Gain
1	WGT	13-130-JL5050	PIFA Antenna	2.98 dBi for 2.4 GHz

Note: The antenna of EUT is conforming to FCC 15.203.

802.11b/g/n-20MHz Center Frequency of Each Channel:

Channel	Frequency	Channel	Frequency	Channel	Frequency	Channel	Frequency
Channel 01:	2412 MHz	Channel 02:	2417 MHz	Channel 03:	2422 MHz	Channel 04:	2427 MHz
Channel 05:	2432 MHz	Channel 06:	2437 MHz	Channel 07:	2442 MHz	Channel 08:	2447 MHz
Channel 09:	2452 MHz	Channel 10:	2457 MHz	Channel 11:	2462 MHz		

802.11n-40MHz Center Frequency of Each Channel:

Channel	Frequency	Channel	Frequency	Channel	Frequency	Channel	Frequency
Channel 03:	2422 MHz	Channel 04:	2427 MHz	Channel 05:	2432 MHz	Channel 06:	2437 MHz
Channel 07:	2442 MHz	Channel 08:	2447 MHz	Channel 09:	2452 MHz		

Note:

1. The EUT is a Tablet PC with a built-in WLAN and Bluetooth V4.0 、 V2.1+EDR transceiver , this report for 2.4GHz WLAN.
2. Regarding to the operation frequency, the lowest, middle and highest frequency are selected to perform the test.
3. Lowest and highest data rates are tested in each mode. Only worst case is shown in the report. (802.11b is 1Mbps 、 802.11g is 6Mbps 、 802.11n(20M-BW) is 7.2Mbps and 802.11n(40M-BW) is 15Mbps)
4. These tests are conducted on a sample for the purpose of demonstrating compliance of 802.11b/g/n transmitter with Part 15 Subpart C Paragraph 15.247 of spread spectrum devices.
5. The radiation measurements are performed in X, Y, Z axis positioning. Only the worst case is shown in the report.

Test Mode:	Mode 1: Transmit (802.11b 1Mbps)
	Mode 2: Transmit (802.11g 6Mbps)
	Mode 3: Transmit (802.11n MCS0 7.2Mbps 20M-BW)
	Mode 4: Transmit (802.11n MCS0 15Mbps 40M-BW)

1.3. Tested System Details

The types for all equipment, plus descriptions of all cables used in the tested system (including inserted cards) are:

Product	Manufacturer	Model No.	Serial No.	Power Cord
1 Monitor	DELL	U2415	CN-01RMGX-74261-6 3H-09UL-A02	Non-shielded, 1.8m
2 Earphone	Verbatim	N/A	N/A	N/A
3 USB 3.0	WD	WDBUZG0010 BBK-PESN	WX11A166S2Y3	N/A
4 Converter (MicorUSB to USB)	N/A	N/A	N/A	N/A
5 Micro SD Card	Sandisk	32GB	N/A	N/A

Signal Cable Type	Signal cable Description
A Micro HDMI to HDMI Cable	Shielded, 1.8m
B Earphone Cable	Non-shielded, 1m
C USB Cable	Shielded, 0.3m

1.4. Configuration of Tested System

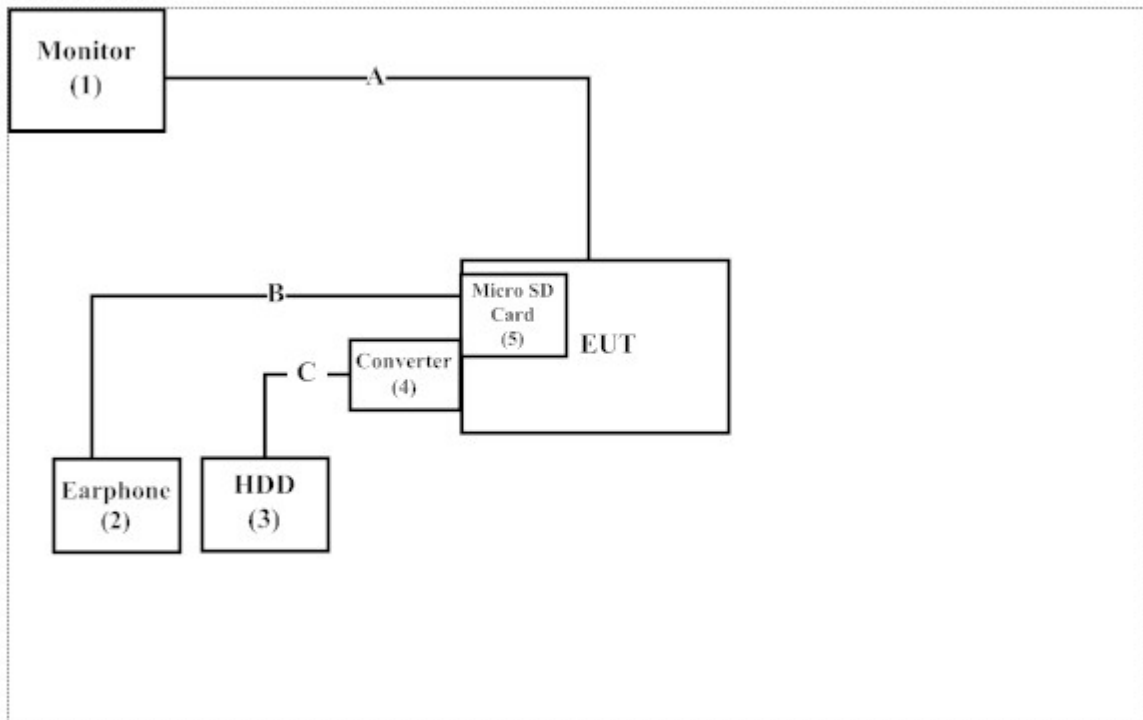

1.5. EUT Exercise Software

1. Setup the EUT as shown in Section 1.4.
2. Execute software “MT6571 va.6C.2” on the EUT.
3. Configure the test mode, the test channel, and the data rate.
4. Press “OK” to start the continuous Transmit.
5. Verify that the EUT works properly.

1.6. Test Facility

Ambient conditions in the laboratory:

Items	Required (IEC 68-1)	Actual
Temperature (°C)	15-35	20-35
Humidity (%RH)	25-75	50-65
Barometric pressure (mbar)	860-1060	950-1000

The related certificate for our laboratories about the test site and management system can be downloaded from DEKRA Testing and Certification Co., Ltd. Web Site:

<http://www.dekra.com.tw/english/about/certificates.aspx?bval=5>

The address and introduction of DEKRA Testing and Certification Co., Ltd. laboratories can be founded in our Web site: http://www.dekra.com.tw/index_en

Site Description: Accredited by TAF
Accredited Number: 3023

Site Name: DEKRA Testing and Certification Co., Ltd.
Site Address: No.159, Sec. 2, Wenhua 1st Rd., Linkou Dist.,
New Taipei City 24457, Taiwan.
TEL: 886-2-2602-7968 / FAX : 866-2-2602-3286
E-Mail : info.tw@dekra.com

FCC Accreditation Number: TW3023

1.7. List of Test Item and Equipment

For Conduction measurements /ASR1

	Equipment	Manufacturer	Model No.	Serial No.	Cali. Data	Due. Data
X	EMI Test Receiver	R&S	ESR7	101602	2017.12.11	2018.12.10
X	Two-Line V-Network	R&S	ENV216	101306	2017.02.16	2018.02.15
X	Two-Line V-Network	R&S	ENV216	101307	2017.03.17	2018.03.16
X	Coaxial Cable	Quietek	RG400_BNC	RF001	2017.05.24	2018.05.23

Note:

1. All equipments are calibrated every one year.
2. The test instruments marked with "X" are used to measure the final test results.
3. Test Software version : QuieTek EMI 2.0 V2.1.113

For Conducted measurements /ASR4

	Equipment	Manufacturer	Model No.	Serial No.	Cali. Data	Due. Data
X	Spectrum Analyzer	R&S	FSV30	103466	2017.12.19	2018.12.18
X	Power Meter	Anritsu	ML2496A	1548003	2017.12.11	2018.12.10
X	Power Sensor	Anritsu	MA2411B	1531024	2017.12.11	2018.12.10
X	Power Sensor	Anritsu	MA2411B	1531025	2017.12.11	2018.12.10

Note:

1. All equipments are calibrated every one year.
2. The test instruments marked with "X" are used to measure the final test results.
3. Test Software version : QuieTek Conduction Test System V8.0.110

For Radiated measurements /ACB1

	Equipment	Manufacturer	Model No.	Serial No.	Cali. Data	Due. Data
X	Loop Antenna	TESEQ	HLA6121	37133	2016.03.18	2018.03.17
X	Bi-Log Antenna	SCHWARZBECK	VULB9168	9168-674	2017.02.13	2018.02.12
X	Horn Antenna	ETS-Lindgren	3117	00203800	2017.11.10	2018.11.09
X	Horn Antenna	Com-Power	AH-840	101087	2017.05.24	2018.05.23
X	Pre-Amplifier	EMCI	EMC001330	980316	2017.05.16	2018.05.15
X	Pre-Amplifier	EMCI	EMC051835SE	980311	2017.05.17	2018.05.16
X	Pre-Amplifier	EMCI	EMC05820SE	980310	2017.05.17	2018.05.16
X	Pre-Amplifier	EMCI	EMC184045SE	980314	2017.05.17	2018.05.16
X	Filter	MICRO TRONICS	BRM50702	G251	2017.08.30	2018.08.29
	Filter	MICRO TRONICS	BRM50716	G188	2017.08.30	2018.08.29
X	EMI Test Receiver	R&S	ESR7	101602	2017.12.11	2018.12.10
X	Spectrum Analyzer	R&S	FSV40	101147	2018.01.11	2019.01.10
X	Coaxial Cable	SUHNER	SUCOFLEX 106	RF002	2017.05.25	2018.05.24
X	Mircoflex Cable	HUBER SUHNER	SUCOFLEX 102	MY3381/2	2017.08.11	2018.08.10

Note:

1. Loop Antenna is calibrated every two year, the other equipments are calibrated every one year.
2. The test instruments marked with "X" are used to measure the final test results.
3. Test Software version : QuieTek EMI 2.0 V2.1.113

2. Conducted Emission

2.1. Test Setup

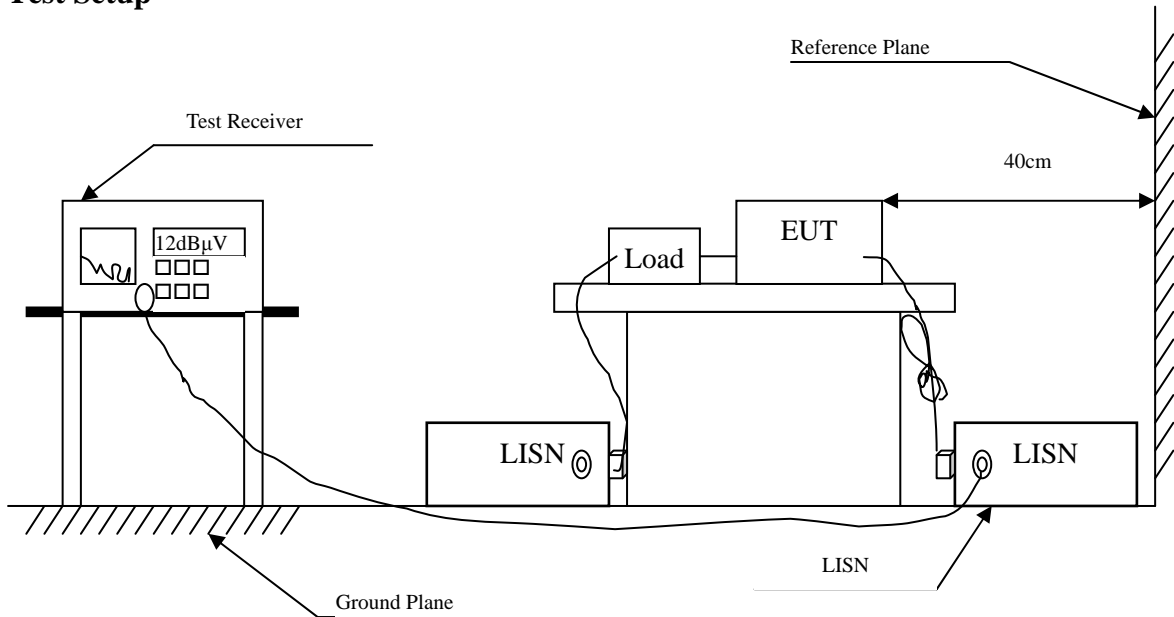

2.2. Limits

FCC Part 15 Subpart C Paragraph 15.207 (dB μ V) Limit		
Frequency MHz	Limits	
	QP	AVG
0.15 - 0.50	66-56	56-46
0.50-5.0	56	46
5.0 - 30	60	50

2.3. Test Procedure

The EUT and simulators are connected to the main power through a line impedance stabilization network (L.I.S.N.). This provides a 50 ohm /50uH coupling impedance for the measuring equipment. The peripheral devices are also connected to the main power through a LISN that provides a 50ohm /50uH coupling impedance with 50ohm termination. (Please refers to the block diagram of the test setup and photographs.)

Both sides of A.C. line are checked for maximum conducted interference. In order to find the maximum emission, the relative positions of equipment and all of the interface cables must be changed according to ANSI C63.4: 2014 on conducted measurement.

Conducted emissions were investigated over the frequency range from 0.15MHz to 30MHz using a receiver bandwidth of 9kHz.

2.4. Uncertainty

± 2.35 dB

2.5. Test Result of Conducted Emission

Product : Tablet PC
 Test Item : Conducted Emission Test
 Power Line : Line 1
 Test Mode : Mode 4: Transmit (802.11n MCS0 15Mbps 40M-BW) (2437MHz)
 Test Date : 2018/01/18

Frequency MHz	Correct Factor dB	Reading Level dB μ V	Measurement Level dB μ V	Margin dB	Limit dB μ V
Line 1					
Quasi-Peak					
0.154	9.622	32.808	42.429	-23.457	65.886
0.427	9.695	27.263	36.958	-21.128	58.086
2.366	9.764	31.854	41.617	-14.383	56.000
2.605	9.766	36.083	45.849	-10.151	56.000
11.089	9.956	37.956	47.912	-12.088	60.000
24.576	10.100	28.914	39.014	-20.986	60.000
Average					
0.154	9.622	15.593	25.215	-30.671	55.886
0.427	9.695	15.861	25.556	-22.530	48.086
2.366	9.764	24.645	34.409	-11.591	46.000
2.605	9.766	26.704	36.470	-9.530	46.000
11.089	9.956	29.311	39.267	-10.733	50.000
24.576	10.100	25.716	35.816	-14.184	50.000

Note:

1. All Reading Levels are Quasi-Peak and average value.
2. "■" means the worst emission level.
3. Measurement Level = Reading Level + Correct Factor

Product : Tablet PC
 Test Item : Conducted Emission Test
 Power Line : Line 2
 Test Mode : Mode 4: Transmit (802.11n MCS0 15Mbps 40M-BW) (2437MHz)
 Test Date : 2018/01/18

Frequency MHz	Correct Factor dB	Reading Level dB μ V	Measurement Level dB μ V	Margin dB	Limit dB μ V
Line 2					
Quasi-Peak					
0.154	9.613	33.571	43.183	-22.703	65.886
0.431	9.688	28.233	37.921	-20.050	57.971
2.683	9.777	33.673	43.450	-12.550	56.000
9.503	9.927	31.306	41.233	-18.767	60.000
11.186	9.962	36.574	46.536	-13.464	60.000
24.576	10.140	28.102	38.242	-21.758	60.000
Average					
0.154	9.613	18.294	27.907	-27.979	55.886
0.431	9.688	18.353	28.041	-19.930	47.971
2.683	9.777	26.748	36.525	-9.475	46.000
9.503	9.927	22.529	32.456	-17.544	50.000
11.186	9.962	27.854	37.816	-12.184	50.000
24.576	10.140	24.382	34.522	-15.478	50.000

Note:

1. All Reading Levels are Quasi-Peak and average value.
2. “” means the worst emission level.
3. Measurement Level = Reading Level + Correct Factor

3. Peak Power Output

3.1. Test Setup



3.2. Limits

The maximum peak power shall be less 1 Watt.

3.3. Test Procedure

Tested according to DTS test procedure of KDB 558074 for compliance to FCC 47CFR 15.247 requirements. The maximum peak conducted output power using KDB 558074 section 9.1.3 PKPM1 Peak power meter method. The maximum average conducted output power using KDB 558074 section 9.2.3.2 Method AVGPM-G (Measurement using a gated RF average-reading power meter)

3.4. Uncertainty

± 0.86 dB

3.5. Test Result of Peak Power Output

Product : Tablet PC
 Test Item : Peak Power Output Data
 Test Mode : Mode 1: Transmit (802.11b 1Mbps)
 Test Date : 2018/01/18

Channel No	Frequency (MHz)	Average Power For different Data Rate (Mbps)				Peak Power	Required Limit	Result
		1	2	5.5	11			
		Measurement Level (dBm)						
01	2412	13.31	-	-	-	16.34	<30dBm	Pass
06	2437	13.39	13.34	13.27	13.22	16.55	<30dBm	Pass
11	2462	13.34	-	-	-	16.32	<30dBm	Pass

Note: Peak Power Output Value = Reading value on power meter + cable loss

Product : Tablet PC
 Test Item : Peak Power Output Data
 Test Mode : Mode 2: Transmit (802.11g 6Mbps)
 Test Date : 2018/01/18

Channel No	Frequency (MHz)	Average Power For different Data Rate (Mbps)								Peak Power	Required Limit	Result
		6	9	12	18	24	36	48	54	6		
		Measurement Level (dBm)										
01	2412	13.36	-	-	-	-	-	-	-	22.10	<30dBm	Pass
06	2437	12.89	12.83	12.78	12.74	12.68	12.64	12.58	12.52	21.94	<30dBm	Pass
11	2462	13.33	-	-	-	-	-	-	-	22.03	<30dBm	Pass

Note: Peak Power Output Value = Reading value on power meter + cable loss

Product : Tablet PC
 Test Item : Peak Power Output Data
 Test Mode : Mode 3: Transmit (802.11n MCS0 7.2Mbps 20M-BW)
 Test Date : 2018/01/18

Channel No	Frequency (MHz)	Average Power								Peak Power	Required Limit	Result
		For different Data Rate (Mbps)										
		7.2	14.4	21.7	28.9	43.3	57.8	65	72.2	7.2		
Measurement Level (dBm)												
01	2412	13.21	-	-	-	-	-	-	-	21.84	<30dBm	Pass
06	2437	13.14	13.09	13.04	12.98	12.93	12.86	12.81	12.76	21.86	<30dBm	Pass
11	2462	13.27	-	-	-	-	-	-	-	22.13	<30dBm	Pass

Note: Peak Power Output Value = Reading value on power meter + cable loss

Product : Tablet PC
 Test Item : Peak Power Output Data
 Test Mode : Mode 4: Transmit (802.11n MCS0 15Mbps 40M-BW)
 Test Date : 2018/01/18

Channel No	Frequency (MHz)	Average Power For different Data Rate (Mbps)								Peak Power	Required Limit	Result
		15	30	45	60	90	120	135	150			
		Measurement Level (dBm)										
03	2422	13.24	-	-	-	-	-	-	-	21.17	<30dBm	Pass
06	2437	13.16	13.11	13.07	13.01	12.97	12.93	12.88	12.83	22.54	<30dBm	Pass
09	2452	13.09	-	-	-	-	-	-	-	21.21	<30dBm	Pass

Note: Peak Power Output Value = Reading value on power meter + cable loss

4. Radiated Emission

4.1. Test Setup

Radiated Emission Under 30MHz

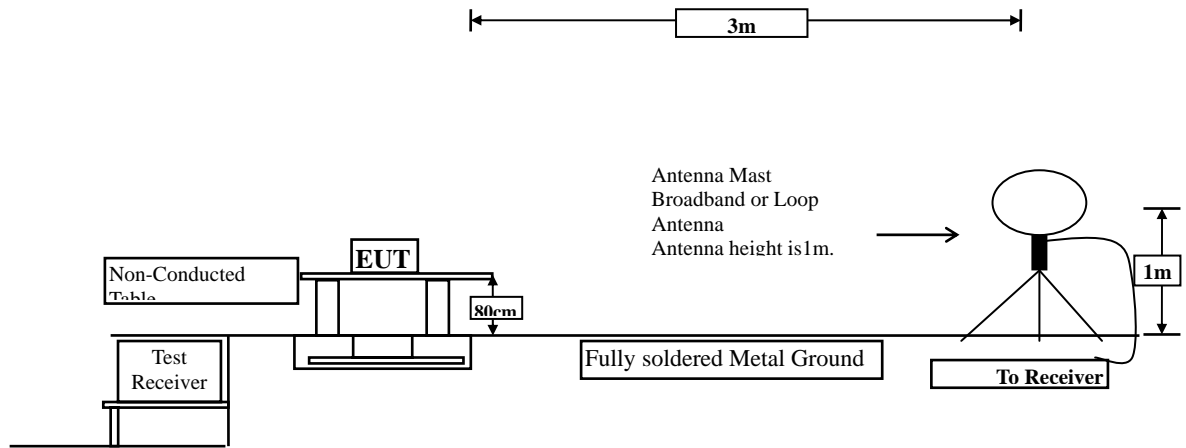

Radiated Emission Below 1GHz

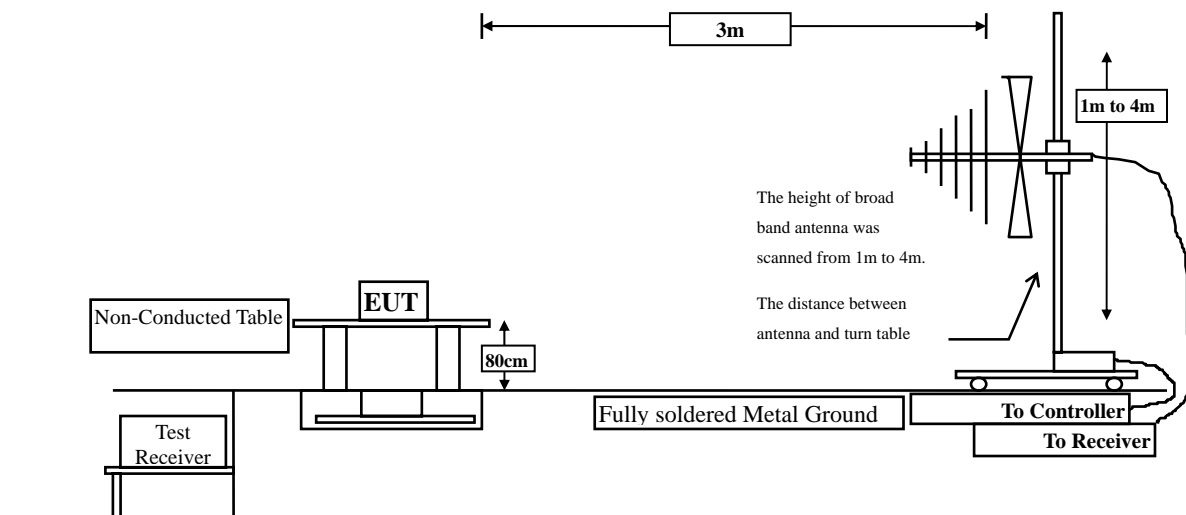

Radiated Emission Above 1GHz

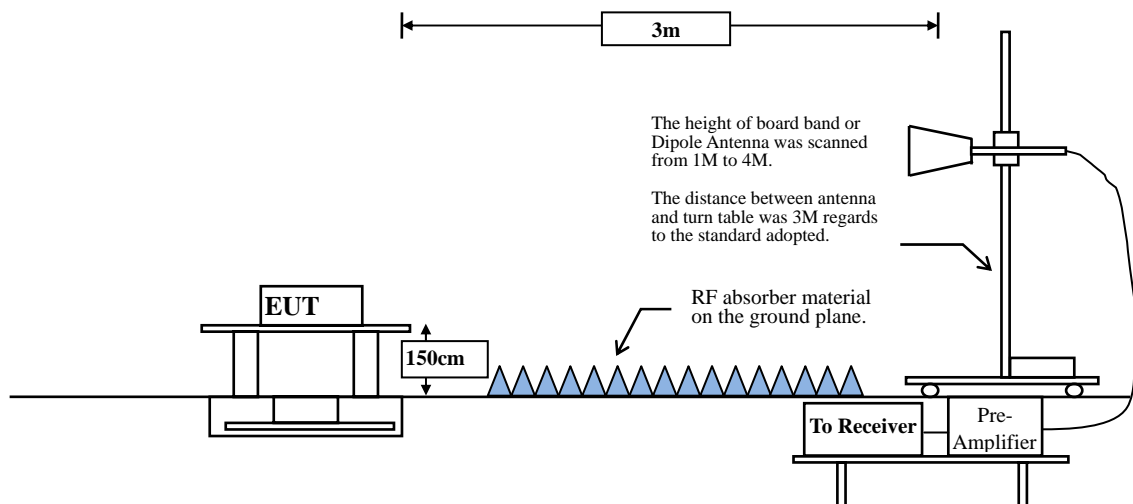

4.2. Limits

➤ General Radiated Emission Limits

Emissions radiated outside of the specified frequency bands, except for harmonics, shall be attenuated by at least 20dB below the level of the fundamental or to the general radiated emission limits in paragraph 15.209, whichever is the lesser attenuation.

FCC Part 15 Subpart C Paragraph 15.209 Limits		
Frequency MHz	Field strength (microvolts/meter)	Measurement distance (meter)
0.009-0.490	2400/F(kHz)	300
0.490-1.705	24000/F(kHz)	30
1.705-30	30	30
30-88	100	3
88-216	150	3
216-960	200	3
Above 960	500	3

- Remarks:
1. RF Voltage (dBuV) = 20 log RF Voltage (uV)
 2. In the Above Table, the tighter limit applies at the band edges.
 3. Distance refers to the distance in meters between the measuring instrument antenna and the closed point of any part of the device or system.

4.3. Test Procedure

The EUT was setup according to ANSI C63.10: 2013 and tested according to DTS test procedure of KDB558074 for compliance to FCC 47CFR 15.247 requirements.

Measuring the frequency range below 1GHz, the EUT is placed on a turn table which is 0.8 meter above ground, when measuring the frequency range above 1GHz, the EUT is placed on a turn table which is 1.5 meter above ground.

The turn table is rotated 360 degrees to determine the position of the maximum emission level.

The EUT was positioned such that the distance from antenna to the EUT was 3 meters.

The antenna is scanned between 1 meter and 4 meters to find out the maximum emission level. This is repeated for both horizontal and vertical polarization of the antenna. In order to find the maximum emission, all of the interface cables were manipulated according to ANSI C63.10: 2013 on radiated measurement.

The resolution bandwidth below 30MHz setting on the field strength meter is 9kHz and 30MHz~1GHz is 120kHz and above 1GHz is 1MHz.

Radiated emission measurements below 30MHz are made using Loop Antenna and 30MHz~1GHz are made using broadband Bilog antenna and above 1GHz are made using Horn Antennas.

The measurement is divided into the Preliminary Measurement and the Final Measurement.

The suspected frequencies are searched for in Preliminary Measurement with the measurement antenna kept pointed at the source of the emission both in azimuth and elevation, with the polarization of the antenna oriented for maximum response. The antenna is pointed at an angle towards the source of the emission, and the EUT is rotated in both height and polarization to maximize the measured emission. The emission is kept within the illumination area of the 3 dB bandwidth of the antenna. The measurement frequency range from 9kHz - 10th Harmonic of fundamental was investigated.

RBW and VBW Parameter setting:

According to KDB 558074 section 12.2.4. Peak power measurement procedure

RBW = as specified in Table 1.

$VBW \geq 3 \times RBW$.

Table 1 —RBW as a function of frequency

Frequency	RBW
9-150 kHz	200-300 Hz
0.15-30 MHz	9-10 kHz
30-1000 MHz	100-120 kHz
> 1000 MHz	1 MHz

According to KDB 558074 section 12.2.5. Average power measurement procedure

RBW = 1MHz.

VBW = 10Hz, when duty cycle $\geq 98 \%$

$VBW \geq 1/T$, when duty cycle $< 98 \%$

(T refers to the minimum transmission duration over which the transmitter is on and is transmitting at its maximum power control level for the tested mode of operation.)

2.4GHz band	Duty Cycle (%)	T (ms)	1/T (Hz)	VBW (Hz)
802.11b	100.00	--	--	10
802.11g	100.00	--	--	10
802.11n20	100.00	--	--	10
802.11n40	100.00	--	--	10

Note: Duty Cycle Refer to Section 9

4.4. Uncertainty

Horizontal polarization :

30-300MHz: ± 4.08 dB ; 300M-1GHz: ± 3.86 dB ; 1-18GHz: ± 3.77 dB ; 18-40GHz: ± 3.98 dB

Vertical polarization :

30-300MHz: ± 4.81 dB ; 300M-1GHz: ± 3.87 dB ; 1-18GHz: ± 3.83 dB ; 18-40GHz: ± 3.98 dB

4.5. Test Result of Radiated Emission

Product : Tablet PC
 Test Item : Harmonic Radiated Emission Data
 Test Mode : Mode 1: Transmit (802.11b 1Mbps) (2412MHz)
 Test Date : 2018/01/16

Frequency MHz	Correct Factor dB	Reading Level dB μ V	Measurement Level dB μ V/m	Margin dB	Limit dB μ V/m
Horizontal					
Peak Detector:					
4824.000	-2.866	56.830	53.964	-20.036	74.000
7236.000	0.381	44.750	45.131	-28.869	74.000
9648.000	2.391	42.930	45.321	-28.679	74.000
Average Detector:					
--	--	--	--	--	54.000
Vertical					
Peak Detector:					
4824.000	-2.866	53.640	50.774	-23.226	74.000
7236.000	0.381	44.690	45.071	-28.929	74.000
9648.000	2.391	42.860	45.251	-28.749	74.000
Average Detector:					
--	--	--	--	--	54.000

Note:

1. All Readings below 1GHz are Quasi-Peak, above 1GHz are performed with peak and/or average measurements as necessary.
2. Measurement Level = Reading Level + Correct Factor.
3. Correct Factor = Antenna factor + Cable loss – Amplifier gain.
4. The average measurement was not performed when the peak measured data under the limit of average detection.
5. The emission levels of other frequencies are very lower than the limit and not show in test report.

Product : Tablet PC
 Test Item : Harmonic Radiated Emission Data
 Test Mode : Mode 1: Transmit (802.11b 1Mbps) (2437 MHz)
 Test Date : 2018/01/16

Frequency MHz	Correct Factor dB	Reading Level dB μ V	Measurement Level dB μ V/m	Margin dB	Limit dB μ V/m
Horizontal					
Peak Detector:					
4874.000	-2.835	49.830	46.994	-27.006	74.000
7311.000	0.465	44.990	45.455	-28.545	74.000
9748.000	2.590	43.820	46.409	-27.591	74.000
Average Detector:					
--	--	--	--	--	54.000
Vertical					
Peak Detector:					
4874.000	-2.835	48.340	45.504	-28.496	74.000
7311.000	0.465	45.150	45.615	-28.385	74.000
9748.000	2.590	43.870	46.459	-27.541	74.000
Average Detector:					
--	--	--	--	--	54.000

Note:

1. All Readings below 1GHz are Quasi-Peak, above 1GHz are performed with peak and/or average measurements as necessary.
2. Measurement Level = Reading Level + Correct Factor.
3. Correct Factor = Antenna factor + Cable loss – Amplifier gain.
4. The average measurement was not performed when the peak measured data under the limit of average detection.
5. The emission levels of other frequencies are very lower than the limit and not show in test report.

Product : Tablet PC
 Test Item : Harmonic Radiated Emission Data
 Test Mode : Mode 1: Transmit (802.11b 1Mbps) (2462 MHz)
 Test Date : 2018/01/16

Frequency MHz	Correct Factor dB	Reading Level dB μ V	Measurement Level dB μ V/m	Margin dB	Limit dB μ V/m
Horizontal					
Peak Detector:					
4924.000	-2.796	54.590	51.794	-22.206	74.000
7386.000	0.489	44.520	45.009	-28.991	74.000
9848.000	2.729	43.380	46.110	-27.890	74.000
Average Detector:					
--	--	--	--	--	54.000
Vertical					
Peak Detector:					
4924.000	-2.796	52.280	49.484	-24.516	74.000
7386.000	0.489	44.910	45.399	-28.601	74.000
9848.000	2.729	43.270	46.000	-28.000	74.000
Average Detector:					
--	--	--	--	--	54.000

Note:

1. All Readings below 1GHz are Quasi-Peak, above 1GHz are performed with peak and/or average measurements as necessary.
2. Measurement Level = Reading Level + Correct Factor.
3. Correct Factor = Antenna factor + Cable loss – Amplifier gain.
4. The average measurement was not performed when the peak measured data under the limit of average detection.
5. The emission levels of other frequencies are very lower than the limit and not show in test report.

Product : Tablet PC
 Test Item : Harmonic Radiated Emission Data
 Test Mode : Mode 2: Transmit (802.11g 6Mbps) (2412MHz)
 Test Date : 2018/01/16

Frequency MHz	Correct Factor dB	Reading Level dB μ V	Measurement Level dB μ V/m	Margin dB	Limit dB μ V/m
Horizontal					
Peak Detector:					
4824.000	-2.866	55.800	52.934	-21.066	74.000
7236.000	0.381	45.350	45.731	-28.269	74.000
9648.000	2.391	43.930	46.321	-27.679	74.000
Average Detector:					
--	--	--	--	--	54.000
Vertical					
Peak Detector:					
4824.000	-2.866	52.400	49.534	-24.466	74.000
7236.000	0.381	44.770	45.151	-28.849	74.000
9648.000	2.391	43.280	45.671	-28.329	74.000
Average Detector:					
--	--	--	--	--	54.000

Note:

1. All Readings below 1GHz are Quasi-Peak, above 1GHz are performed with peak and/or average measurements as necessary.
2. Measurement Level = Reading Level + Correct Factor.
3. Correct Factor = Antenna factor + Cable loss – Amplifier gain.
4. The average measurement was not performed when the peak measured data under the limit of average detection.
5. The emission levels of other frequencies are very lower than the limit and not show in test report.

Product : Tablet PC
 Test Item : Harmonic Radiated Emission Data
 Test Mode : Mode 2: Transmit (802.11g 6Mbps) (2437 MHz)
 Test Date : 2018/01/16

Frequency MHz	Correct Factor dB	Reading Level dB μ V	Measurement Level dB μ V/m	Margin dB	Limit dB μ V/m
Horizontal					
Peak Detector:					
4874.000	-2.835	49.620	46.784	-27.216	74.000
7311.000	0.465	46.080	46.545	-27.455	74.000
9748.000	2.590	44.230	46.819	-27.181	74.000
Average Detector:					
--	--	--	--	--	54.000
Vertical					
Peak Detector:					
4874.000	-2.835	46.910	44.074	-29.926	74.000
7311.000	0.465	45.810	46.275	-27.725	74.000
9748.000	2.590	43.920	46.509	-27.491	74.000
Average Detector:					
--	--	--	--	--	54.000

Note:

1. All Readings below 1GHz are Quasi-Peak, above 1GHz are performed with peak and/or average measurements as necessary.
2. Measurement Level = Reading Level + Correct Factor.
3. Correct Factor = Antenna factor + Cable loss – Amplifier gain.
4. The average measurement was not performed when the peak measured data under the limit of average detection.
5. The emission levels of other frequencies are very lower than the limit and not show in test report.

Product : Tablet PC
 Test Item : Harmonic Radiated Emission Data
 Test Mode : Mode 2: Transmit (802.11g 6Mbps) (2462 MHz)
 Test Date : 2018/01/16

Frequency MHz	Correct Factor dB	Reading Level dBμV	Measurement Level dBμV/m	Margin dB	Limit dBμV/m
Horizontal					
Peak Detector:					
4924.000	-2.796	53.610	50.814	-23.186	74.000
7386.000	0.489	44.520	45.009	-28.991	74.000
9848.000	2.729	43.350	46.080	-27.920	74.000
Average Detector:					
--	--	--	--	--	54.000
Vertical					
Peak Detector:					
4924.000	-2.796	51.850	49.054	-24.946	74.000
7386.000	0.489	44.790	45.279	-28.721	74.000
9848.000	2.729	43.440	46.170	-27.830	74.000
Average Detector:					
--	--	--	--	--	54.000

Note:

1. All Readings below 1GHz are Quasi-Peak, above 1GHz are performed with peak and/or average measurements as necessary.
2. Measurement Level = Reading Level + Correct Factor.
3. Correct Factor = Antenna factor + Cable loss – Amplifier gain.
4. The average measurement was not performed when the peak measured data under the limit of average detection.
5. The emission levels of other frequencies are very lower than the limit and not show in test report.

Product : Tablet PC
 Test Item : Harmonic Radiated Emission Data
 Test Mode : Mode 3: Transmit (802.11n MCS0 7.2Mbps 20M-BW)(2412MHz)
 Test Date : 2018/01/16

Frequency MHz	Correct Factor dB	Reading Level dB μ V	Measurement Level dB μ V/m	Margin dB	Limit dB μ V/m
Horizontal					
Peak Detector:					
4824.000	-2.866	56.340	53.474	-20.526	74.000
7236.000	0.381	44.970	45.351	-28.649	74.000
9648.000	2.391	43.670	46.061	-27.939	74.000
Average Detector:					
--	--	--	--	--	54.000
Vertical					
Peak Detector:					
4824.000	-2.866	53.160	50.294	-23.706	74.000
7236.000	0.381	44.760	45.141	-28.859	74.000
9648.000	2.391	42.690	45.081	-28.919	74.000
Average Detector:					
--	--	--	--	--	54.000

Note:

1. All Readings below 1GHz are Quasi-Peak, above 1GHz are performed with peak and/or average measurements as necessary.
2. Measurement Level = Reading Level + Correct Factor.
3. Correct Factor = Antenna factor + Cable loss – Amplifier gain.
4. The average measurement was not performed when the peak measured data under the limit of average detection.
5. The emission levels of other frequencies are very lower than the limit and not show in test report.

Product : Tablet PC
 Test Item : Harmonic Radiated Emission Data
 Test Mode : Mode 3: Transmit (802.11n MCS0 7.2Mbps 20M-BW) (2437 MHz)
 Test Date : 2018/01/16

Frequency MHz	Correct Factor dB	Reading Level dB μ V	Measurement Level dB μ V/m	Margin dB	Limit dB μ V/m
Horizontal					
Peak Detector:					
4874.000	-2.835	50.730	47.894	-26.106	74.000
7311.000	0.465	45.780	46.245	-27.755	74.000
9748.000	2.590	44.760	47.349	-26.651	74.000
Average Detector:					
--	--	--	--	--	54.000
Vertical					
Peak Detector:					
4874.000	-2.835	47.480	44.644	-29.356	74.000
7311.000	0.465	45.210	45.675	-28.325	74.000
9748.000	2.590	44.710	47.299	-26.701	74.000
Average Detector:					
--	--	--	--	--	54.000

Note:

1. All Readings below 1GHz are Quasi-Peak, above 1GHz are performed with peak and/or average measurements as necessary.
2. Measurement Level = Reading Level + Correct Factor.
3. Correct Factor = Antenna factor + Cable loss – Amplifier gain.
4. The average measurement was not performed when the peak measured data under the limit of average detection.
5. The emission levels of other frequencies are very lower than the limit and not show in test report.

Product : Tablet PC
 Test Item : Harmonic Radiated Emission Data
 Test Mode : Mode 3: Transmit (802.11n MCS0 7.2Mbps 20M-BW) (2462 MHz)
 Test Date : 2018/01/16

Frequency MHz	Correct Factor dB	Reading Level dBµV	Measurement Level dBµV/m	Margin dB	Limit dBµV/m
Horizontal					
Peak Detector:					
4924.000	-2.796	53.760	50.964	-23.036	74.000
7386.000	0.489	45.110	45.599	-28.401	74.000
9848.000	2.729	43.980	46.710	-27.290	74.000
Average Detector:					
--	--	--	--	--	54.000
Vertical					
Peak Detector:					
4924.000	-2.796	51.780	48.984	-25.016	74.000
7386.000	0.489	44.240	44.729	-29.271	74.000
9848.000	2.729	43.560	46.290	-27.710	74.000
Average Detector:					
--	--	--	--	--	54.000

Note:

1. All Readings below 1GHz are Quasi-Peak, above 1GHz are performed with peak and/or average measurements as necessary.
2. Measurement Level = Reading Level + Correct Factor.
3. Correct Factor = Antenna factor + Cable loss – Amplifier gain.
4. The average measurement was not performed when the peak measured data under the limit of average detection.
5. The emission levels of other frequencies are very lower than the limit and not show in test report.

Product : Tablet PC
 Test Item : Harmonic Radiated Emission Data
 Test Mode : Mode 4: Transmit (802.11n MCS0 15Mbps 40M-BW)(2422MHz)
 Test Date : 2018/01/16

Frequency MHz	Correct Factor dB	Reading Level dB μ V	Measurement Level dB μ V/m	Margin dB	Limit dB μ V/m
Horizontal					
Peak Detector:					
4844.000	-2.852	50.370	47.518	-26.482	74.000
7266.000	0.426	45.140	45.566	-28.434	74.000
9688.000	2.479	43.980	46.459	-27.541	74.000
Average Detector:					
--	--	--	--	--	54.000
Vertical					
Peak Detector:					
4844.000	-2.852	47.350	44.498	-29.502	74.000
7266.000	0.426	45.180	45.606	-28.394	74.000
9688.000	2.479	43.110	45.589	-28.411	74.000
Average Detector:					
--	--	--	--	--	54.000

Note:

1. All Readings below 1GHz are Quasi-Peak, above 1GHz are performed with peak and/or average measurements as necessary.
2. Measurement Level = Reading Level + Correct Factor.
3. Correct Factor = Antenna factor + Cable loss – Amplifier gain.
4. The average measurement was not performed when the peak measured data under the limit of average detection.
5. The emission levels of other frequencies are very lower than the limit and not show in test report.

Product : Tablet PC
 Test Item : Harmonic Radiated Emission Data
 Test Mode : Mode 4: Transmit (802.11n MCS0 15Mbps 40M-BW) (2437 MHz)
 Test Date : 2018/01/16

Frequency MHz	Correct Factor dB	Reading Level dB μ V	Measurement Level dB μ V/m	Margin dB	Limit dB μ V/m
Horizontal					
Peak Detector:					
4874.000	-2.835	48.910	46.074	-27.926	74.000
7311.000	0.465	45.400	45.865	-28.135	74.000
9748.000	2.590	44.210	46.799	-27.201	74.000
Average Detector:					
--	--	--	--	--	54.000
Vertical					
Peak Detector:					
4874.000	-2.835	46.810	43.974	-30.026	74.000
7311.000	0.465	44.810	45.275	-28.725	74.000
9748.000	2.590	44.230	46.819	-27.181	74.000
Average Detector:					
--	--	--	--	--	54.000

Note:

1. All Readings below 1GHz are Quasi-Peak, above 1GHz are performed with peak and/or average measurements as necessary.
2. Measurement Level = Reading Level + Correct Factor.
3. Correct Factor = Antenna factor + Cable loss – Amplifier gain.
4. The average measurement was not performed when the peak measured data under the limit of average detection.
5. The emission levels of other frequencies are very lower than the limit and not show in test report.

Product : Tablet PC
 Test Item : Harmonic Radiated Emission Data
 Test Mode : Mode 4: Transmit (802.11n MCS0 15Mbps 40M-BW)(2452 MHz)
 Test Date : 2018/01/16

Frequency MHz	Correct Factor dB	Reading Level dB μ V	Measurement Level dB μ V/m	Margin dB	Limit dB μ V/m
Horizontal					
Peak Detector:					
4904.000	-2.828	48.930	46.102	-27.898	74.000
7356.000	0.473	45.120	45.592	-28.408	74.000
9808.000	2.719	44.030	46.750	-27.250	74.000
Average Detector:					
--	--	--	--	--	54.000
Vertical					
Peak Detector:					
4904.000	-2.828	47.710	44.882	-29.118	74.000
7356.000	0.473	44.870	45.342	-28.658	74.000
9808.000	2.719	43.760	46.480	-27.520	74.000
Average Detector:					
--	--	--	--	--	54.000

Note:

1. All Readings below 1GHz are Quasi-Peak, above 1GHz are performed with peak and/or average measurements as necessary.
2. Measurement Level = Reading Level + Correct Factor.
3. Correct Factor = Antenna factor + Cable loss – Amplifier gain.
4. The average measurement was not performed when the peak measured data under the limit of average detection.
5. The emission levels of other frequencies are very lower than the limit and not show in test report.

Product : Tablet PC
 Test Item : General Radiated Emission Data
 Test Mode : Mode 1: Transmit (802.11b 1Mbps)(2437 MHz)
 Test Date : 2018/01/18

Frequency MHz	Correct Factor dB	Reading Level dB μ V	Measurement Level dB μ V/m	Margin dB	Limit dB μ V/m
Horizontal					
63.739	-12.434	37.606	25.172	-14.828	40.000
146.681	-10.722	37.917	27.195	-16.305	43.500
351.928	-8.702	38.548	29.846	-16.154	46.000
408.159	-7.153	38.123	30.970	-15.030	46.000
824.275	-0.024	30.598	30.573	-15.427	46.000
962.043	1.626	30.469	32.095	-21.905	54.000
Vertical					
48.275	-10.834	42.936	32.102	-7.898	40.000
195.884	-13.430	42.724	29.294	-14.206	43.500
405.348	-7.219	35.102	27.883	-18.117	46.000
606.377	-3.015	30.817	27.803	-18.197	46.000
746.957	-0.924	34.693	33.769	-12.231	46.000
924.087	1.169	30.983	32.151	-13.849	46.000

Note:

1. All Readings below 1GHz are Quasi-Peak, above 1GHz are performed with peak and/or average measurements as necessary.
2. Measurement Level = Reading Level + Correct Factor.
3. Correct Factor = Antenna factor + Cable loss – Amplifier gain.
4. The emission levels of other frequencies are very lower than the limit and not show in test report.
5. No emission found between lowest internal used/generated frequency to 30MHz.

Product : Tablet PC
 Test Item : General Radiated Emission Data
 Test Mode : Mode 2: Transmit (802.11g 6Mbps)(2437 MHz)
 Test Date : 2018/01/18

Frequency MHz	Correct Factor dB	Reading Level dB μ V	Measurement Level dB μ V/m	Margin dB	Limit dB μ V/m
Horizontal					
129.812	-11.968	37.469	25.501	-17.999	43.500
198.696	-13.469	39.198	25.728	-17.772	43.500
406.754	-7.186	37.055	29.869	-16.131	46.000
742.739	-0.989	30.841	29.852	-16.148	46.000
839.739	0.186	31.778	31.964	-14.036	46.000
988.754	2.043	29.427	31.470	-22.530	54.000
Vertical					
46.870	-10.839	42.798	31.959	-8.041	40.000
194.478	-13.411	41.742	28.331	-15.169	43.500
399.725	-7.349	34.415	27.066	-18.934	46.000
592.319	-3.252	31.225	27.973	-18.027	46.000
887.536	0.781	30.494	31.275	-14.725	46.000
977.507	1.867	29.666	31.533	-22.467	54.000

Note:

1. All Readings below 1GHz are Quasi-Peak, above 1GHz are performed with peak and/or average measurements as necessary.
2. Measurement Level = Reading Level + Correct Factor.
3. Correct Factor = Antenna factor + Cable loss – Amplifier gain.
4. The emission levels of other frequencies are very lower than the limit and not show in test report.
5. No emission found between lowest internal used/generated frequency to 30MHz.

Product : Tablet PC
 Test Item : General Radiated Emission Data
 Test Mode : Mode 3: Transmit (802.11n MCS0 7.2Mbps 20M-BW)(2437 MHz)
 Test Date : 2018/01/18

Frequency MHz	Correct Factor dB	Reading Level dB μ V	Measurement Level dB μ V/m	Margin dB	Limit dB μ V/m
Horizontal					
48.275	-10.834	33.729	22.895	-17.105	40.000
163.551	-10.584	35.439	24.856	-18.644	43.500
406.754	-7.186	36.972	29.786	-16.214	46.000
634.493	-2.769	30.355	27.586	-18.414	46.000
808.812	-0.219	31.228	31.009	-14.991	46.000
991.565	2.085	29.466	31.551	-22.449	54.000
Vertical					
46.870	-10.839	42.011	31.172	-8.828	40.000
194.478	-13.411	39.002	25.591	-17.909	43.500
403.942	-7.251	33.818	26.567	-19.433	46.000
610.594	-2.978	31.328	28.350	-17.650	46.000
886.130	0.764	31.612	32.376	-13.624	46.000
997.188	2.178	29.896	32.075	-21.925	54.000

Note:

1. All Readings below 1GHz are Quasi-Peak, above 1GHz are performed with peak and/or average measurements as necessary.
2. Measurement Level = Reading Level + Correct Factor.
3. Correct Factor = Antenna factor + Cable loss – Amplifier gain.
4. The emission levels of other frequencies are very lower than the limit and not show in test report.
5. No emission found between lowest internal used/generated frequency to 30MHz.

Product : Tablet PC
 Test Item : General Radiated Emission Data
 Test Mode : Mode 4: Transmit (802.11n MCS0 15Mbps 40M-BW)(2437 MHz)
 Test Date : 2018/01/18

Frequency MHz	Correct Factor dB	Reading Level dB μ V	Measurement Level dB μ V/m	Margin dB	Limit dB μ V/m
Horizontal					
128.406	-12.117	37.702	25.585	-17.915	43.500
354.739	-8.623	37.497	28.874	-17.126	46.000
409.565	-7.121	35.643	28.522	-17.478	46.000
633.087	-2.782	30.531	27.750	-18.250	46.000
818.652	-0.094	31.065	30.971	-15.029	46.000
983.130	1.951	29.680	31.631	-22.369	54.000
Vertical					
46.870	-10.839	42.978	32.139	-7.861	40.000
197.290	-13.451	39.777	26.326	-17.174	43.500
403.942	-7.251	34.237	26.986	-19.014	46.000
592.319	-3.252	31.122	27.870	-18.130	46.000
843.957	0.235	31.105	31.340	-14.660	46.000
994.377	2.128	29.342	31.470	-22.530	54.000

Note:

1. All Readings below 1GHz are Quasi-Peak, above 1GHz are performed with peak and/or average measurements as necessary.
2. Measurement Level = Reading Level + Correct Factor.
3. Correct Factor = Antenna factor + Cable loss – Amplifier gain.
4. The emission levels of other frequencies are very lower than the limit and not show in test report.
5. No emission found between lowest internal used/generated frequency to 30MHz.

5. RF antenna conducted test

5.1. Test Setup

RF antenna Conducted Measurement:

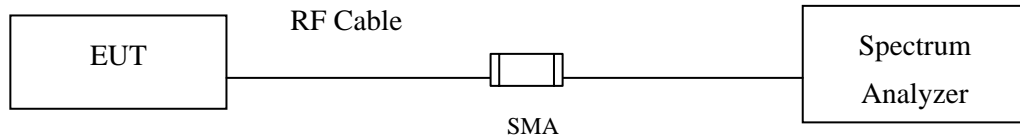

5.2. Limits

In any 100 kHz bandwidth outside the frequency band in which the spread spectrum intentional radiator is operating, the radio frequency power that is produced by the intentional radiator shall be at least 20 dB below that in the 100 kHz bandwidth within the band that contains the highest level of the desired power, based on either an RF conducted or a radiated measurement. Attenuation below the general limits specified in Section 15.209(a) is not required. In addition, radiated emissions which fall in the restricted bands, as defined in Section 15.205(a), must also comply with the radiated emission limits specified in Section 15.209(a) (see Section 15.205(c)).

5.3. Test Procedure

The EUT was tested according to DTS test procedure of KDB558074 for compliance to FCC 47CFR 15.247 requirements.

Set RBW = 100 kHz, Set VBW > RBW, scan up through 10th harmonic.

5.4. Uncertainty

$\pm 1.23\text{dB}$

5.5. Test Result of RF antenna conducted test

Product : Tablet PC
Test Item : RF antenna conducted test
Test Mode : Mode 1: Transmit (802.11b 1Mbps)
Test Date : 2018/01/15

Channel 01 (2412MHz)

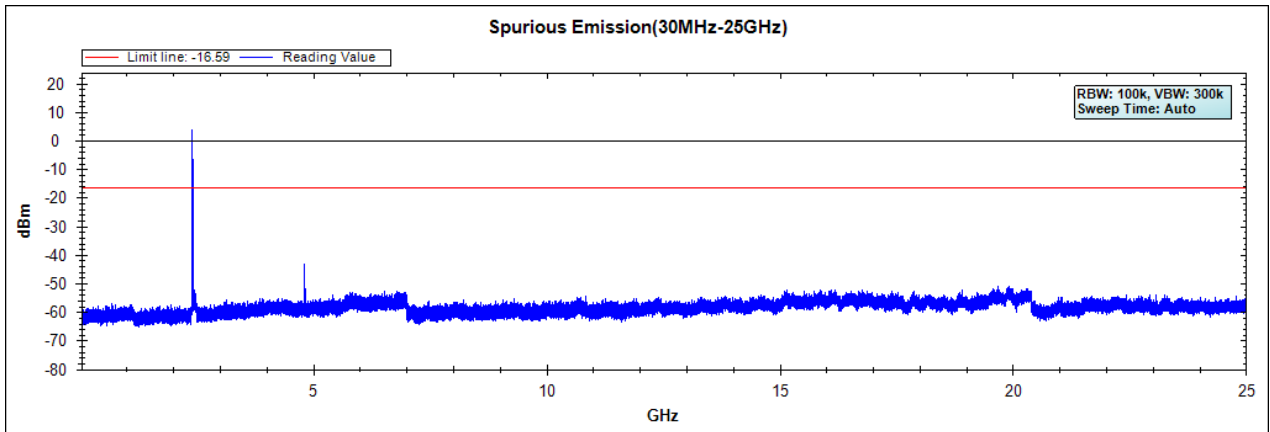

Channel 06 (2437MHz)

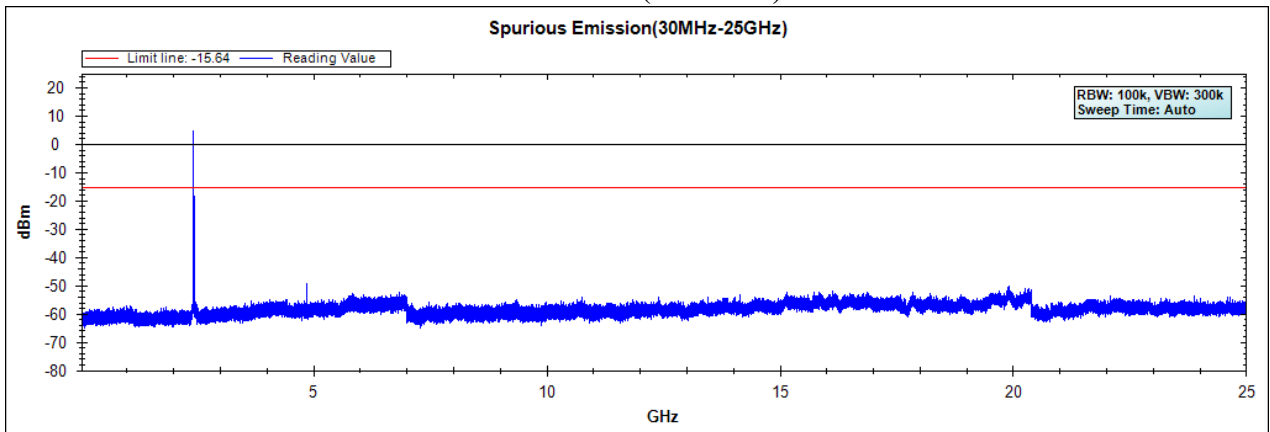

Channel 11 (2462MHz)

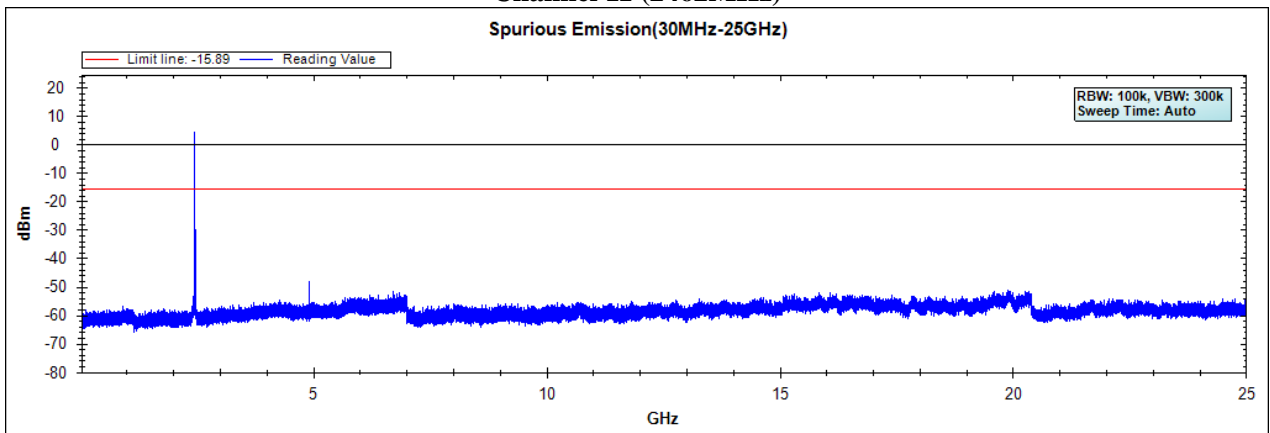

Note: The above test pattern is synthesized by multiple of the frequency range.

Product : Tablet PC
Test Item : RF Antenna Conducted Spurious
Test Mode : Mode 2: Transmit (802.11g 6Mbps)
Test Date : 2018/01/15

Channel 01 (2412MHz)

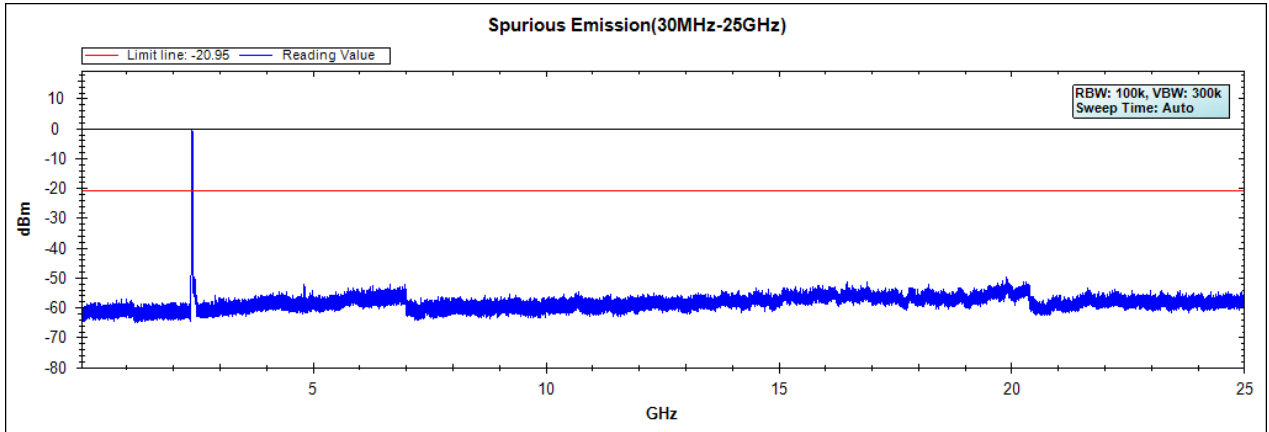

Channel 06 (2437MHz)

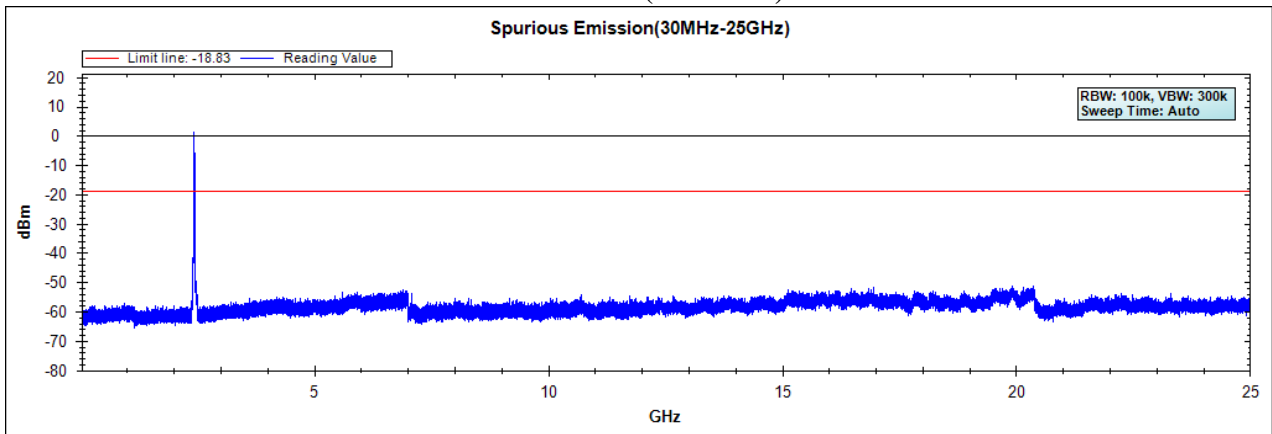

Channel 11 (2462MHz)

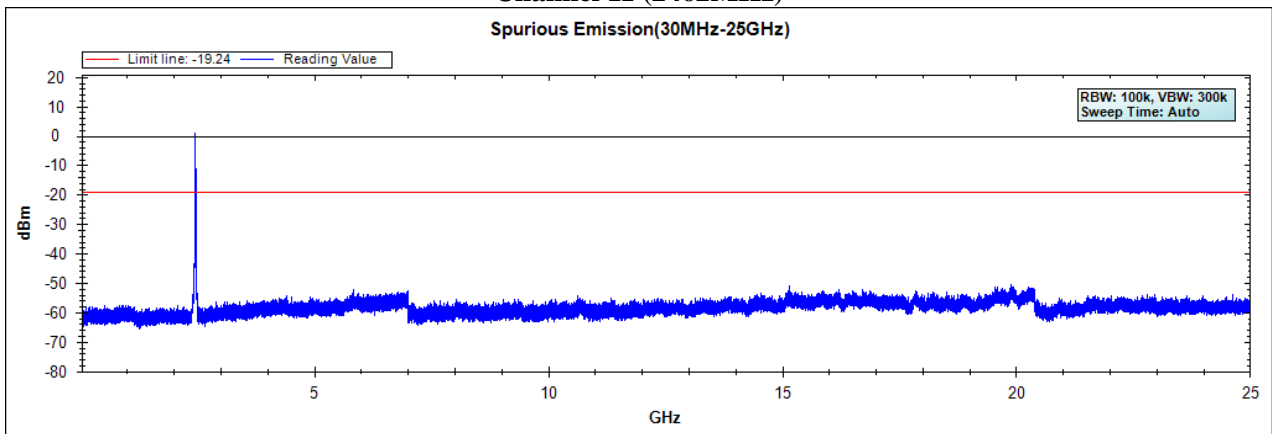

Note: The above test pattern is synthesized by multiple of the frequency range.

Product : Tablet PC
Test Item : RF Antenna Conducted Spurious
Test Mode : Mode 3: Transmit (802.11n MCS0 7.2Mbps 20M-BW)
Test Date : 2018/01/15

Channel 01 (2412MHz)

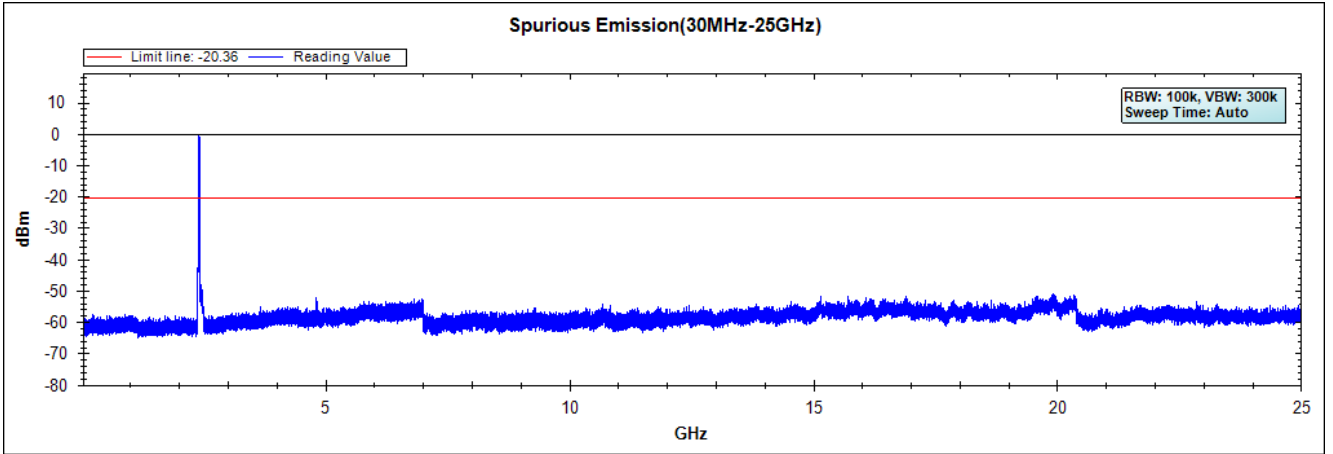

Channel 06 (2437MHz)

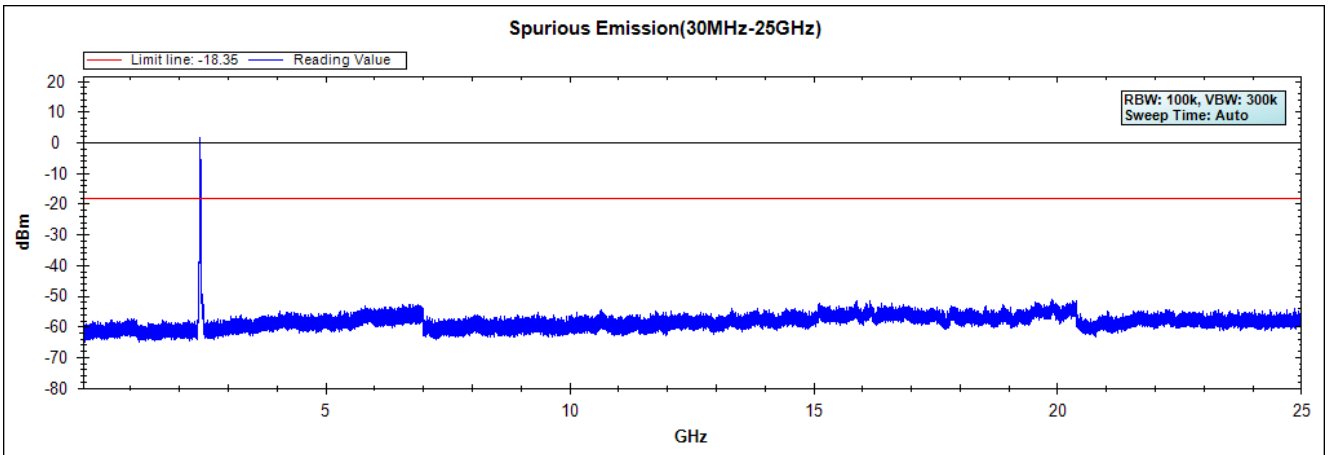

Channel 11 (2462MHz)

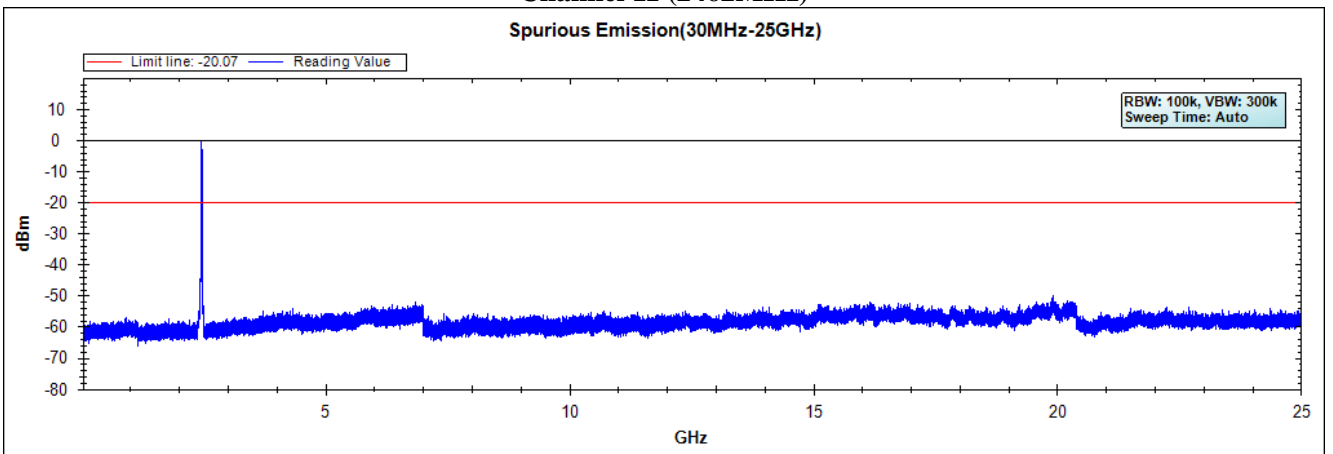

Note: The above test pattern is synthesized by multiple of the frequency range.

Product : Tablet PC
Test Item : RF Antenna Conducted Spurious
Test Mode : Mode 4: Transmit (802.11n MCS0 15Mbps 40M-BW)
Test Date : 2018/01/15

Channel 03 (2422MHz)

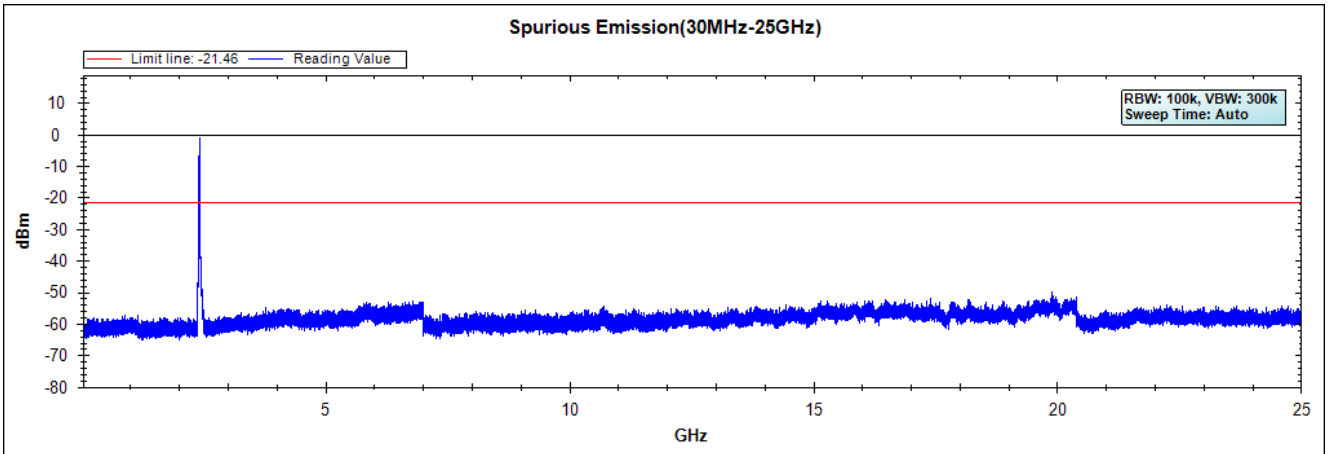

Channel 06 (2437MHz)

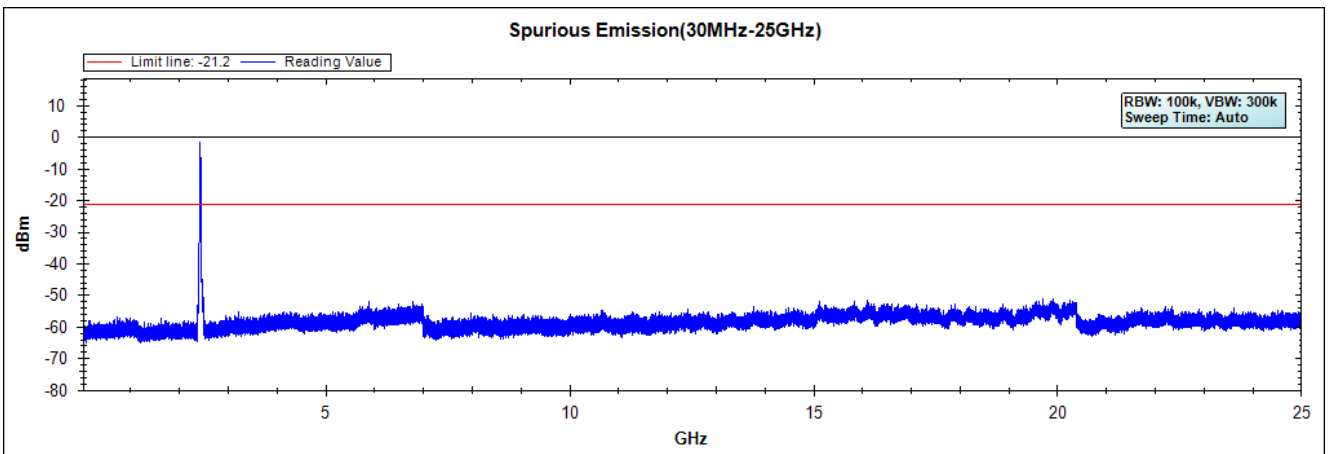

Channel 09 (2452MHz)

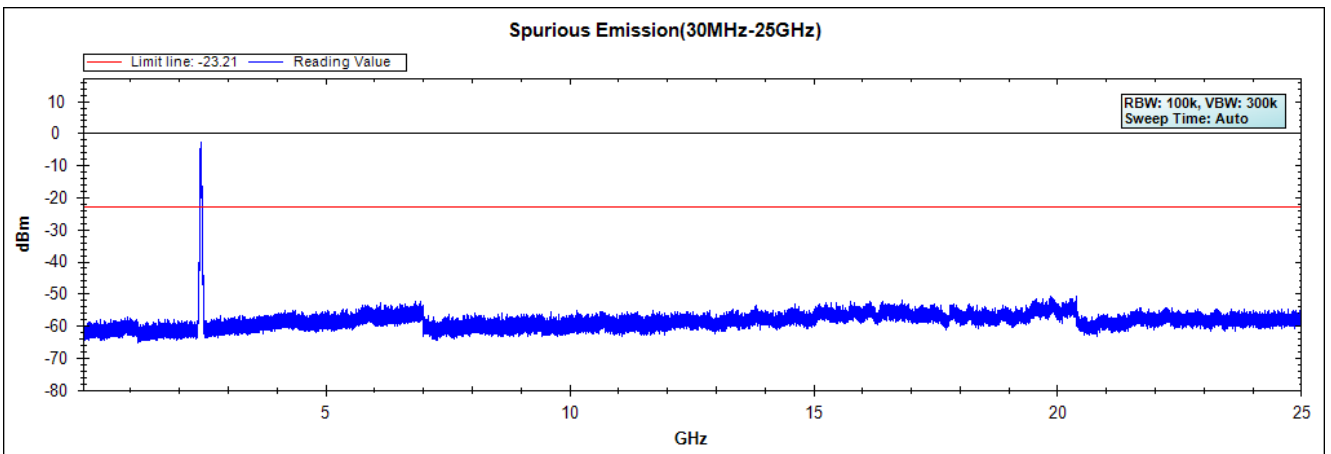

Note: The above test pattern is synthesized by multiple of the frequency range.

6. Band Edge

6.1. Test Setup

RF Conducted Measurement

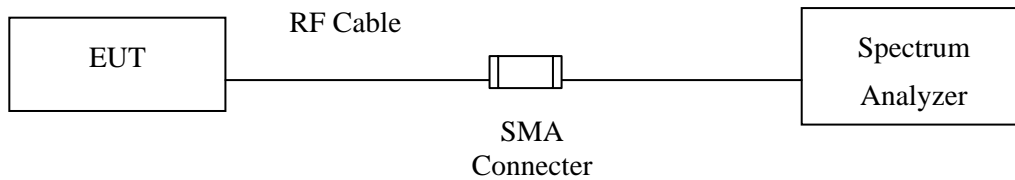

RF Radiated Measurement:

Above 1GHz

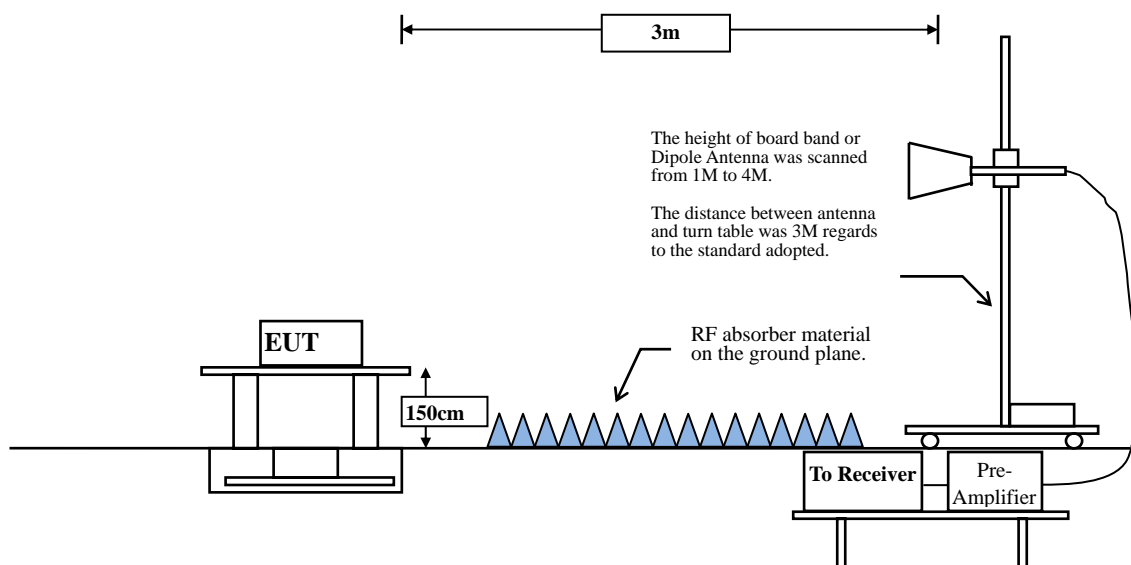

6.2. Limits

According to FCC Section 15.247(d). In any 100 kHz bandwidth outside the frequency band in which the spread spectrum or digitally modulated intentional radiator is operating, the radio frequency power that is produced by the intentional radiator shall be at least 20 dB below that in the 100 kHz bandwidth within the band that contains the highest level of the desired power, based on either an RF conducted or measurement, provided the transmitter demonstrates compliance with the peak conducted power limits. If the transmitter complies with the conducted power limits based on the use of RMS averaging over a time interval, the attenuation required under this paragraph shall be 30 dB instead of 20 dB. Attenuation below the general limits specified in Section 15.209(a) is not required. In addition, radiated emissions which fall in the restricted bands, as defined in Section 15.205(a), must also comply with the radiated emission limits specified in Section 15.209(a) (see Section 15.205(c)).

6.3. Test Procedure

The EUT was setup according to ANSI C63.10, 2013 and tested according to DTS test procedure of KDB558074 for compliance to FCC 47CFR 15.247 requirements.

The EUT is placed on a turn table which is 1.5 meter above ground. The turn table is rotated 360 degrees to determine the position of the maximum emission level. The EUT was positioned such that the distance from antenna to the EUT was 3 meters.

The antenna is scanned from 1 meter to 4 meters to find out the maximum emission level. This is repeated for both horizontal and vertical polarization of the antenna. In order to find the maximum emission, all of the interface cables were manipulated according to ANSI C63.10:2013 on radiated measurement.

RBW and VBW Parameter setting:

According to KDB 558074 section 12.2.4. Peak power measurement procedure

RBW = as specified in Table 1.

$VBW \geq 3 \times RBW$.

Table 1 —RBW as a function of frequency

Frequency	RBW
9-150 kHz	200-300 Hz
0.15-30 MHz	9-10 kHz
30-1000 MHz	100-120 kHz
> 1000 MHz	1 MHz

According to KDB 558074 section 12.2.5. Average power measurement procedure

RBW = 1MHz.

VBW = 10Hz, when duty cycle ≥ 98 %

$VBW \geq 1/T$, when duty cycle < 98 %

(T refers to the minimum transmission duration over which the transmitter is on and is transmitting at its maximum power control level for the tested mode of operation.)

2.4GHz band	Duty Cycle (%)	T (ms)	1/T (Hz)	VBW (Hz)
802.11b	100.00	--	--	10
802.11g	100.00	--	--	10
802.11n20	100.00	--	--	10
802.11n40	100.00	--	--	10

Note: Duty Cycle Refer to Section 9

6.4. Uncertainty

Conducted: ± 1.23 dB

Radiated:

Horizontal polarization : 1-18GHz: ± 3.77 dB

Vertical polarization : 1-18GHz : ± 3.83 dB

6.5. Test Result of Band Edge

Product : Tablet PC
 Test Item : Band Edge Data
 Test Mode : Mode 1: Transmit (802.11b 1Mbps) (2412MHz)
 Test Date : 2018/01/16

RF Radiated Measurement (Horizontal):

Channel No.	Frequency (MHz)	Correct Factor (dB)	Reading Level (dBμV)	Emission Level (dBμV/m)	Peak Limit (dBμV/m)	Average Limit (dBμV/m)	Result
01 (Peak)	2390.000	12.148	32.908	45.056	74.00	54.00	Pass
01 (Peak)	2400.000	12.176	45.179	57.355	--	--	Pass
01 (Peak)	2410.870	12.201	90.039	102.240	--	--	--
01 (Average)	2390.000	12.148	20.466	32.614	74.00	54.00	Pass
01 (Average)	2399.130	12.174	38.230	50.403	--	--	Pass
01 (Average)	2400.000	12.176	36.513	48.689	--	--	Pass
01 (Average)	2411.304	12.201	86.978	99.180	--	--	--

Figure Channel 01: Horizontal (Peak)

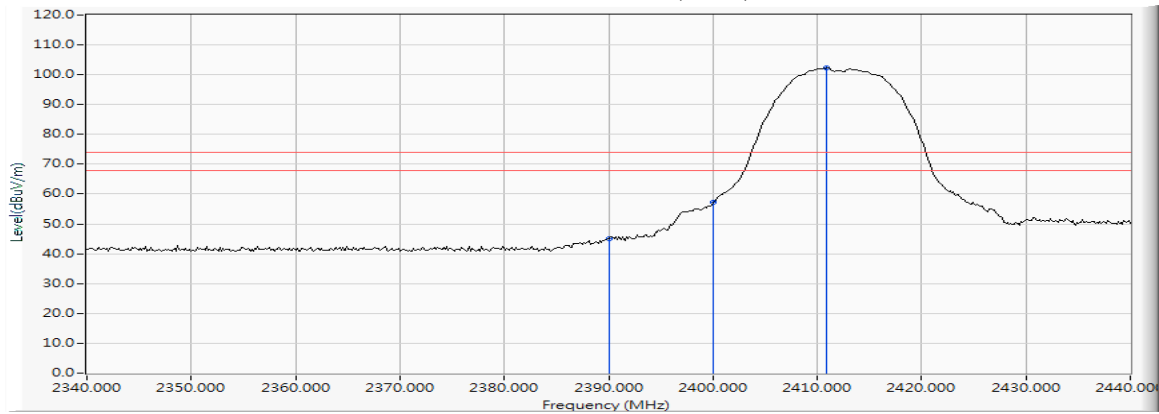
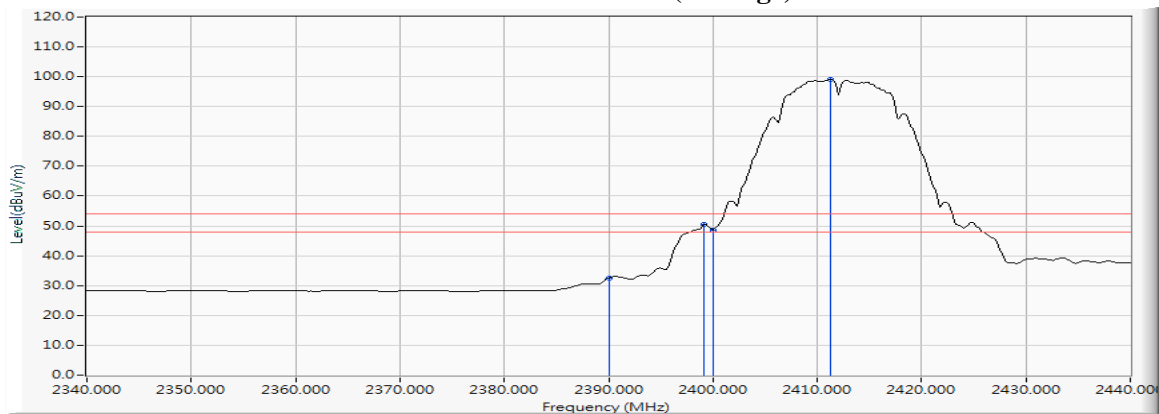

Figure Channel 01: Horizontal (Average)



Note:

1. All readings above 1GHz are performed with peak and/or average measurements as necessary.
2. Measurement Level = Reading Level + Correct Factor.
3. The average measurement was not performed when the peak measured data under the limit of average detection.

Product : Tablet PC
 Test Item : Band Edge Data
 Test Mode : Mode 1: Transmit (802.11b 1Mbps) (2412MHz)
 Test Date : 2018/01/16

RF Radiated Measurement (VERTICAL):

Channel No.	Frequency (MHz)	Correct Factor (dB)	Reading Level (dBμV)	Emission Level (dBμV/m)	Peak Limit (dBμV/m)	Average Limit (dBμV/m)	Result
01 (Peak)	2390.000	12.148	34.422	46.570	74.00	54.00	Pass
01 (Peak)	2400.000	12.176	47.575	59.751	--	--	Pass
01 (Peak)	2411.014	12.201	92.041	104.242	--	--	--
01 (Average)	2390.000	12.148	21.610	33.758	74.00	54.00	Pass
01 (Average)	2399.420	12.174	41.093	53.267	--	--	Pass
01 (Average)	2400.000	12.176	39.454	51.630	--	--	Pass
01 (Average)	2411.304	12.201	88.922	101.124	--	--	--

Figure Channel 01: VERTICAL (Peak)

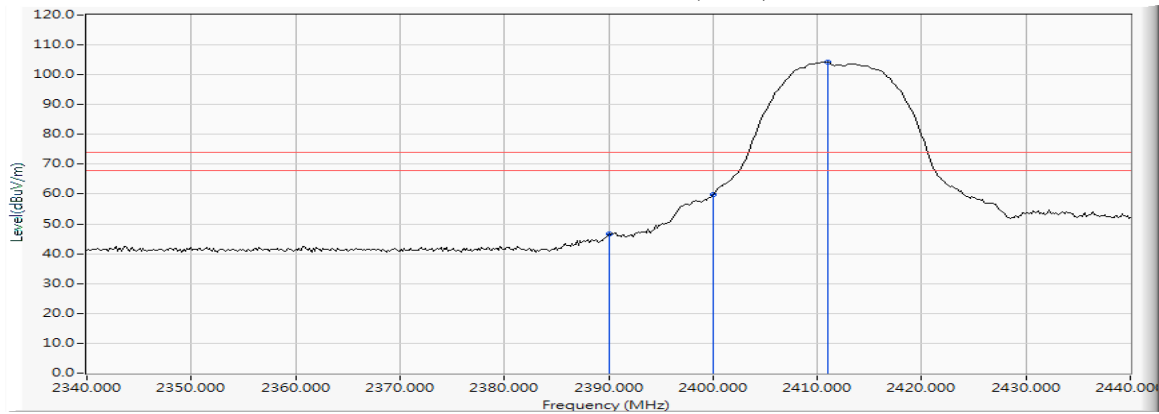
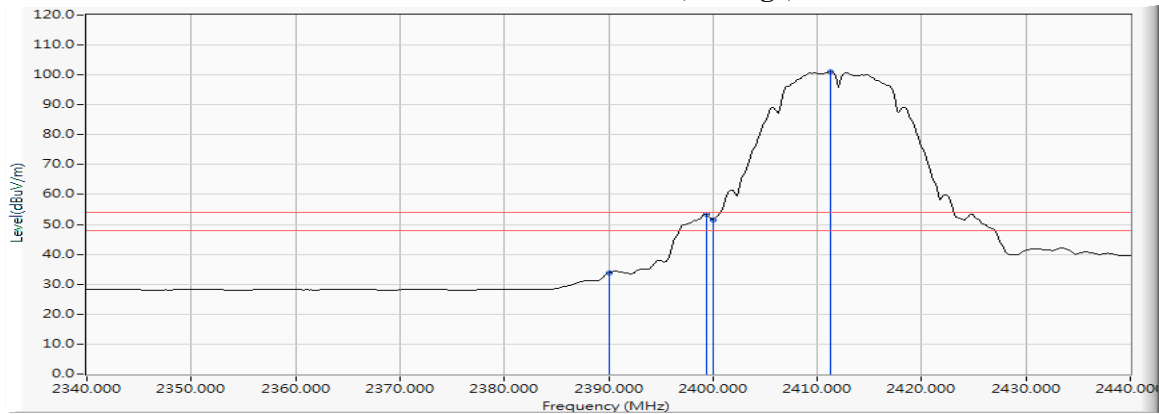

Figure Channel 01: VERTICAL (Average)



Note:

1. All readings above 1GHz are performed with peak and/or average measurements as necessary.
2. Measurement Level = Reading Level + Correct Factor.
3. The average measurement was not performed when the peak measured data under the limit of average detection.

Product : Tablet PC
 Test Item : Band Edge Data
 Test Mode : Mode 1: Transmit (802.11b 1Mbps) (2462MHz)
 Test Date : 2018/01/16

RF Radiated Measurement (Horizontal):

Channel No.	Frequency (MHz)	Correct Factor (dB)	Reading Level (dBμV)	Emission Level (dBμV/m)	Peak Limit (dBμV/m)	Average Limit (dBμV/m)	Result
11 (Peak)	2463.065	12.345	90.253	102.597	--	--	--
11 (Peak)	2483.500	12.403	34.536	46.939	74.00	54.00	Pass
11 (Peak)	2499.007	12.442	35.593	48.034	74.00	54.00	Pass
11 (Average)	2462.775	12.344	87.177	99.521	--	--	--
11 (Average)	2483.500	12.403	22.399	34.802	74.00	54.00	Pass
11 (Average)	2484.225	12.404	22.429	34.834	74.00	54.00	Pass

Figure Channel 11: Horizontal (Peak)

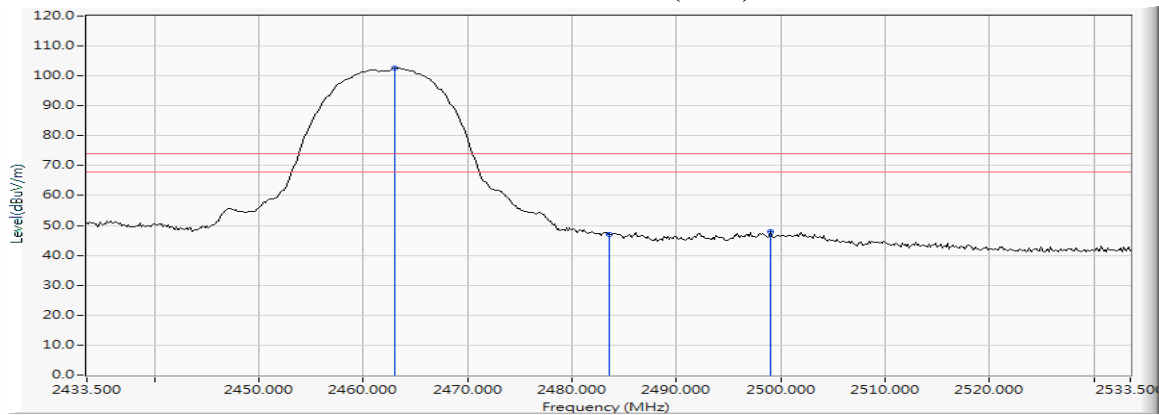
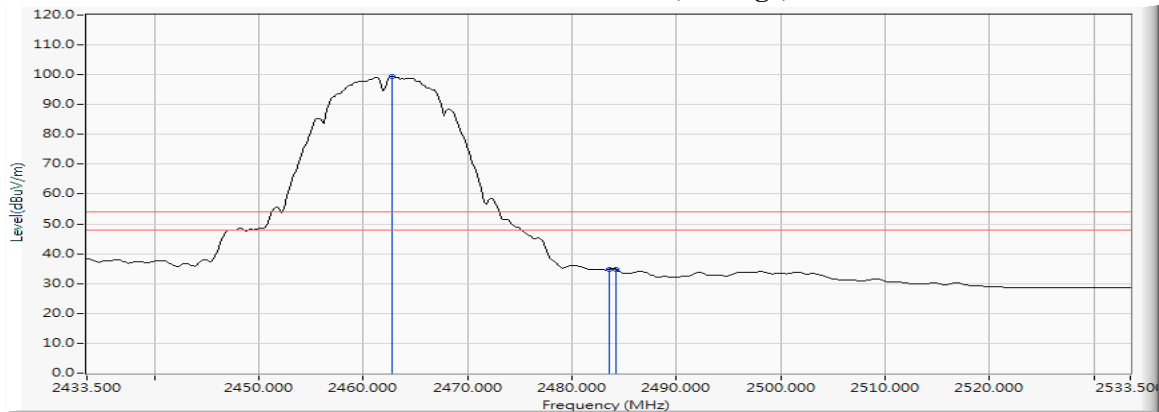

Figure Channel 11: Horizontal (Average)



Note:

1. All readings above 1GHz are performed with peak and/or average measurements as necessary.
2. Measurement Level = Reading Level + Correct Factor.
3. The average measurement was not performed when the peak measured data under the limit of average detection.

Product : Tablet PC
 Test Item : Band Edge Data
 Test Mode : Mode 1: Transmit (802.11b 1Mbps) (2462MHz)
 Test Date : 2018/01/16

RF Radiated Measurement (VERTICAL):

Channel No.	Frequency (MHz)	Correct Factor (dB)	Reading Level (dBμV)	Emission Level (dBμV/m)	Peak Limit (dBμV/m)	Average Limit (dBμV/m)	Result
11 (Peak)	2463.065	12.345	92.950	105.294	--	--	--
11 (Peak)	2483.500	12.403	37.210	49.613	74.00	54.00	Pass
11 (Peak)	2499.007	12.442	37.285	49.726	74.00	54.00	Pass
11 (Average)	2462.775	12.344	89.873	102.217	--	--	--
11 (Average)	2483.500	12.403	24.720	37.123	74.00	54.00	Pass
11 (Average)	2483.790	12.403	24.980	37.383	74.00	54.00	Pass

Figure Channel 11: VERTICAL (Peak)

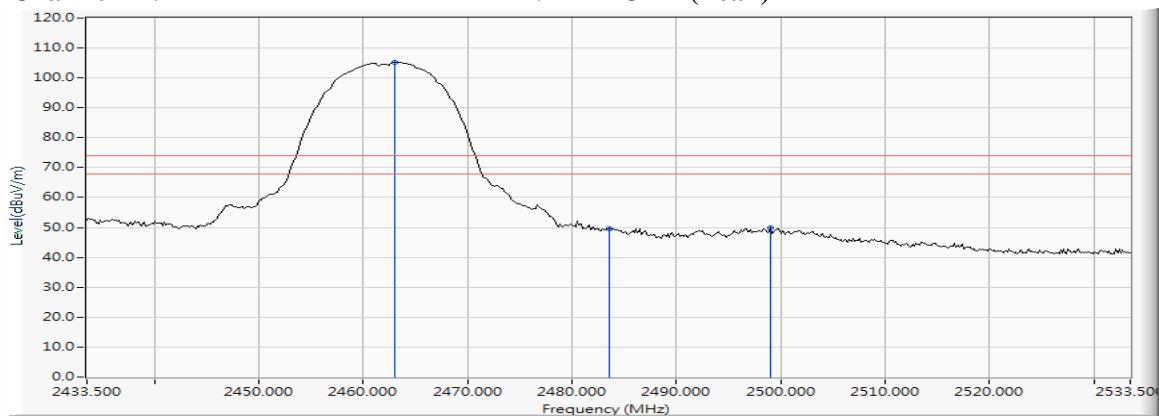
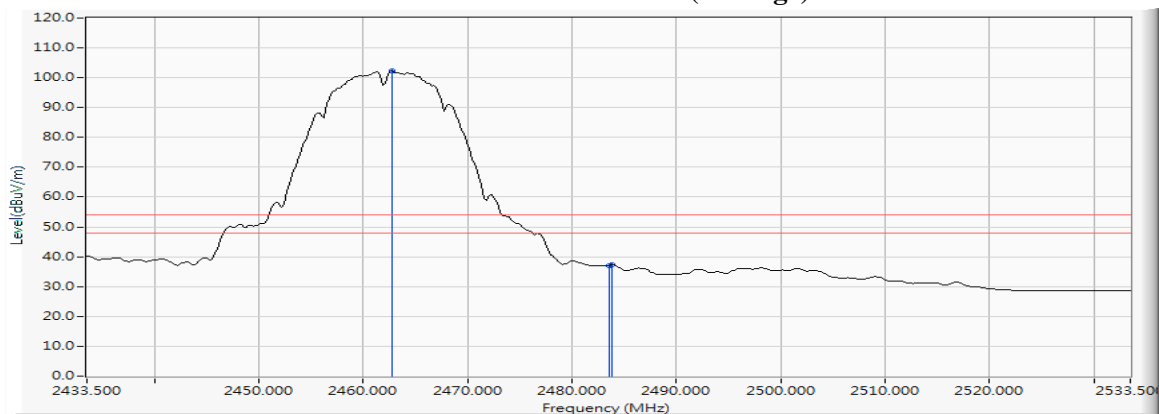

Figure Channel 11: VERTICAL (Average)



Note:

1. All readings above 1GHz are performed with peak and/or average measurements as necessary.
2. Measurement Level = Reading Level + Correct Factor.
3. The average measurement was not performed when the peak measured data under the limit of average detection.

Product : Tablet PC
 Test Item : Band Edge Data
 Test Mode : Mode 2: Transmit (802.11g 6Mbps) (2412MHz)
 Test Date : 2018/01/16

RF Radiated Measurement (Horizontal):

Channel No.	Frequency (MHz)	Correct Factor (dB)	Reading Level (dBμV)	Emission Level (dBμV/m)	Peak Limit (dBμV/m)	Average Limit (dBμV/m)	Result
01 (Peak)	2390.000	12.148	48.675	60.823	74.00	54.00	Pass
01 (Peak)	2400.000	12.176	65.304	77.480	--	--	Pass
01 (Peak)	2410.870	12.201	93.803	106.004	--	--	--
01 (Average)	2390.000	12.148	31.368	43.516	74.00	54.00	Pass
01 (Average)	2400.000	12.176	49.982	62.158	--	--	Pass
01 (Average)	2411.014	12.201	84.750	96.951	--	--	--

Figure Channel 01: Horizontal (Peak)

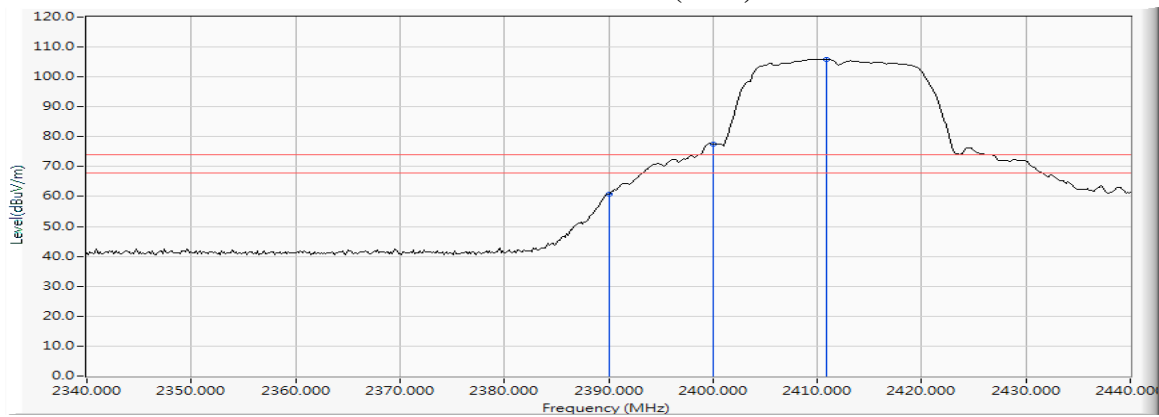
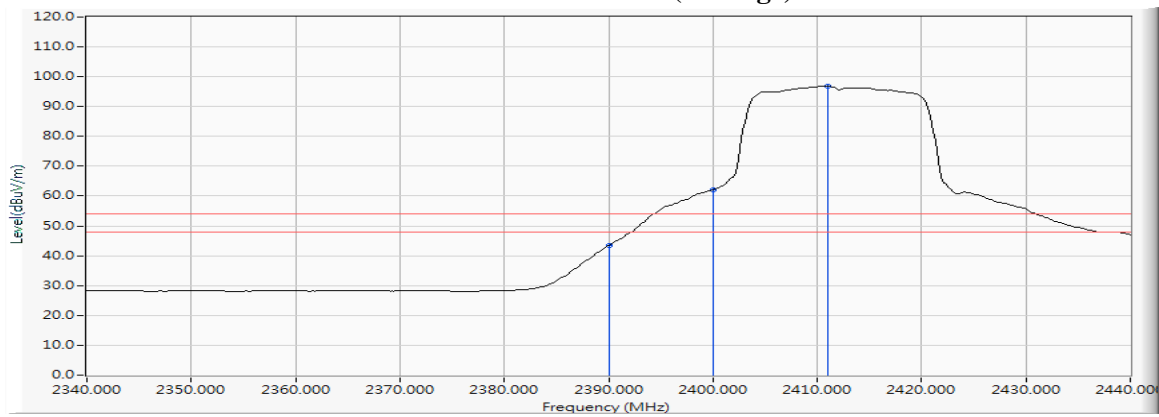

Figure Channel 01: Horizontal (Average)



Note:

1. All readings above 1GHz are performed with peak and/or average measurements as necessary.
2. Measurement Level = Reading Level + Correct Factor.
3. The average measurement was not performed when the peak measured data under the limit of average detection.

Product : Tablet PC
 Test Item : Band Edge Data
 Test Mode : Mode 2: Transmit (802.11g 6Mbps) (2412MHz)
 Test Date : 2018/01/16

RF Radiated Measurement (VERTICAL):

Channel No.	Frequency (MHz)	Correct Factor (dB)	Reading Level (dBμV)	Emission Level (dBμV/m)	Peak Limit (dBμV/m)	Average Limit (dBμV/m)	Result
01 (Peak)	2390.000	12.148	47.160	59.308	74.00	54.00	Pass
01 (Peak)	2400.000	12.176	64.894	77.070	--	--	Pass
01 (Peak)	2410.870	12.201	93.615	105.816	--	--	--
01 (Average)	2390.000	12.148	29.934	42.082	74.00	54.00	Pass
01 (Average)	2400.000	12.176	49.614	61.790	--	--	Pass
01 (Average)	2411.014	12.201	84.615	96.816	--	--	--

Figure Channel 01: VERTICAL (Peak)

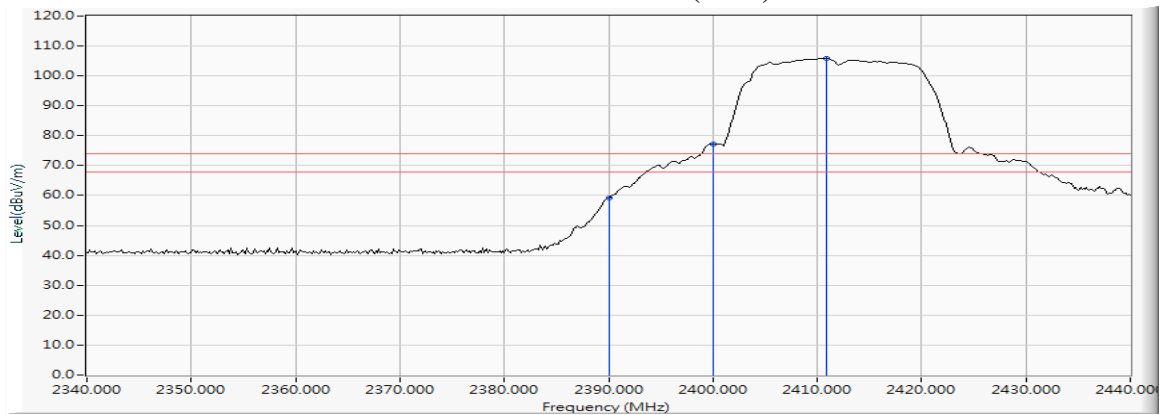
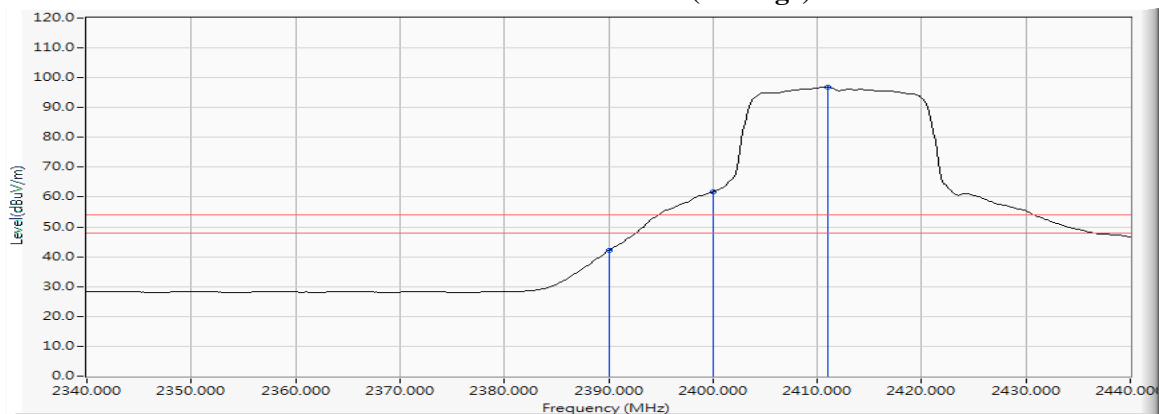

Figure Channel 01: VERTICAL (Average)



Note:

1. All readings above 1GHz are performed with peak and/or average measurements as necessary.
2. Measurement Level = Reading Level + Correct Factor.
3. The average measurement was not performed when the peak measured data under the limit of average detection.

Product : Tablet PC
 Test Item : Band Edge Data
 Test Mode : Mode 2: Transmit (802.11g 6Mbps) (2462MHz)
 Test Date : 2018/01/16

RF Radiated Measurement (Horizontal):

Channel No.	Frequency (MHz)	Correct Factor (dB)	Reading Level (dBμV)	Emission Level (dBμV/m)	Peak Limit (dBμV/m)	Average Limit (dBμV/m)	Result
11 (Peak)	2463.065	12.345	92.295	104.639	--	--	--
11 (Peak)	2483.500	12.403	47.103	59.506	74.00	54.00	Pass
11 (Average)	2463.065	12.345	83.116	95.460	--	--	--
11 (Average)	2483.500	12.403	30.105	42.508	74.00	54.00	Pass

Figure Channel 11: Horizontal (Peak)

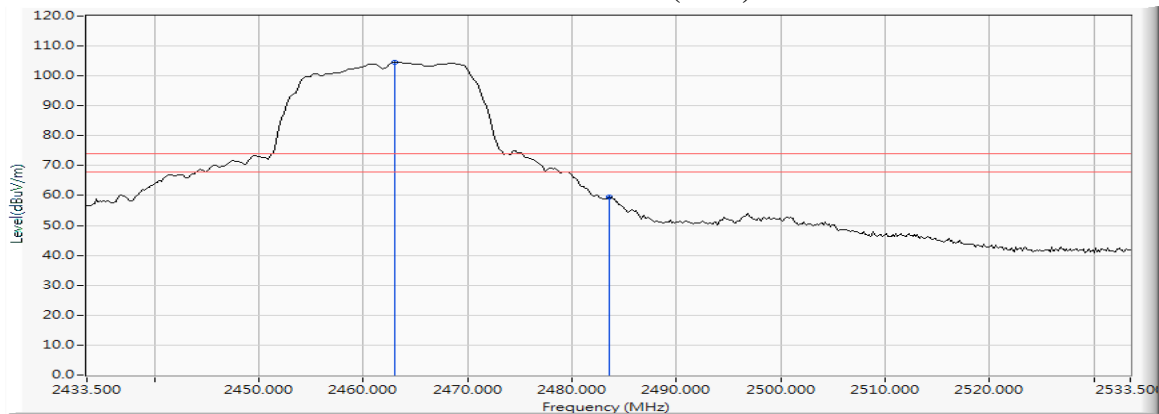
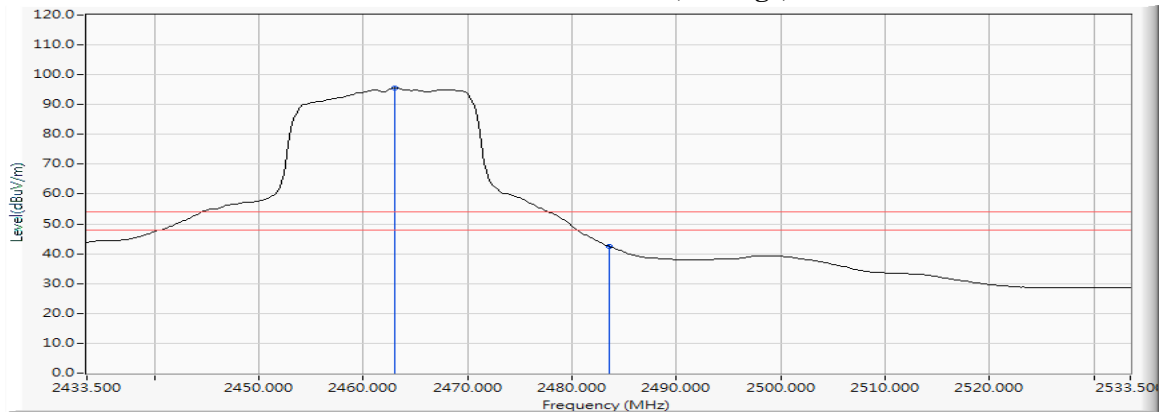

Figure Channel 11: Horizontal (Average)



Note:

1. All readings above 1GHz are performed with peak and/or average measurements as necessary.
2. Measurement Level = Reading Level + Correct Factor.
3. The average measurement was not performed when the peak measured data under the limit of average detection.

Product : Tablet PC
 Test Item : Band Edge Data
 Test Mode : Mode 2: Transmit (802.11g 6Mbps) (2462MHz)
 Test Date : 2018/01/16

RF Radiated Measurement (VERTICAL):

Channel No.	Frequency (MHz)	Correct Factor (dB)	Reading Level (dBμV)	Emission Level (dBμV/m)	Peak Limit (dBμV/m)	Average Limit (dBμV/m)	Result
11 (Peak)	2463.065	12.345	95.402	107.746	--	--	--
11 (Peak)	2483.500	12.403	49.744	62.147	74.00	54.00	Pass
11 (Peak)	2483.790	12.403	49.880	62.283	74.00	54.00	Pass
11 (Average)	2463.065	12.345	86.218	98.562	--	--	--
11 (Average)	2483.500	12.403	33.157	45.560	74.00	54.00	Pass

Figure Channel 11: VERTICAL (Peak)

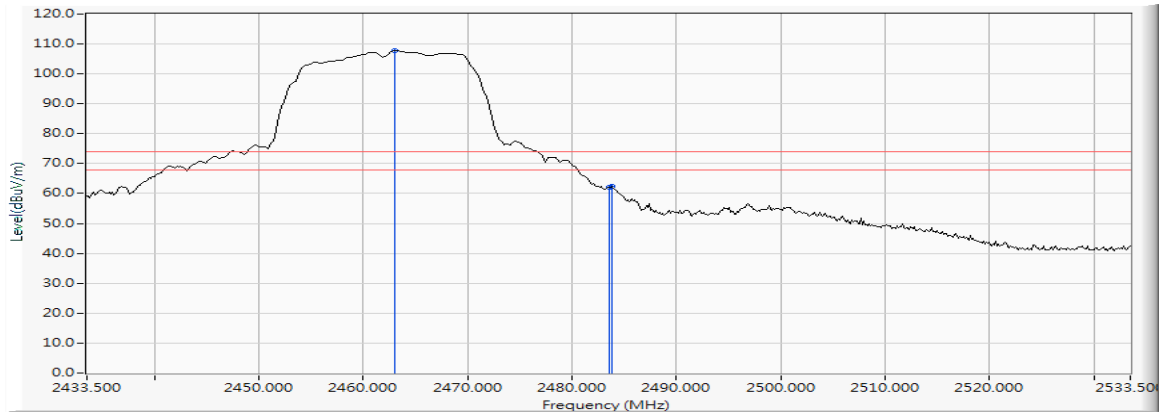
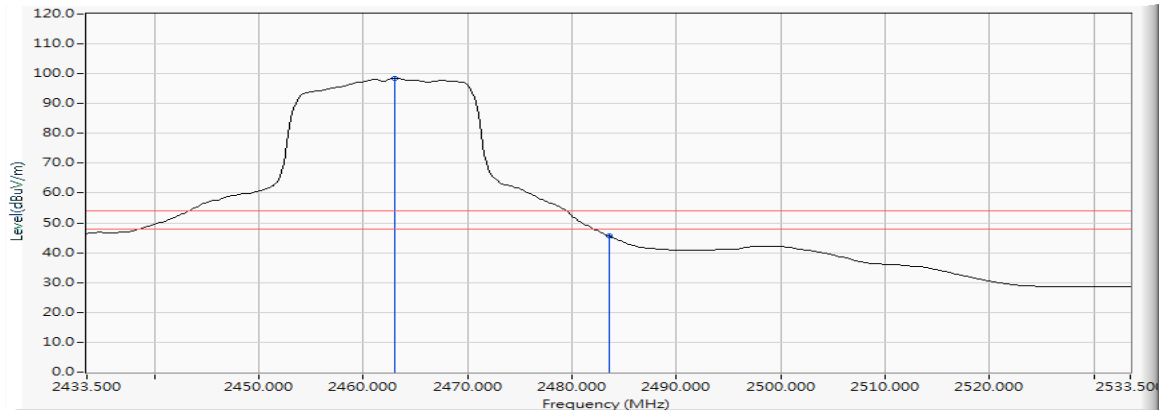

Figure Channel 11: VERTICAL (Average)



Note:

1. All readings above 1GHz are performed with peak and/or average measurements as necessary.
2. Measurement Level = Reading Level + Correct Factor.
3. The average measurement was not performed when the peak measured data under the limit of average detection.

Product : Tablet PC
 Test Item : Band Edge Data
 Test Mode : Mode 3: Transmit (802.11n MCS0 7.2Mbps 20M-BW) (2412MHz)
 Test Date : 2018/01/16

RF Radiated Measurement (Horizontal):

Channel No.	Frequency (MHz)	Correct Factor (dB)	Reading Level (dBμV)	Emission Level (dBμV/m)	Peak Limit (dBμV/m)	Average Limit (dBμV/m)	Result
01 (Peak)	2390.000	12.148	53.677	65.825	74.00	54.00	Pass
01 (Peak)	2400.000	12.176	65.708	77.884	--	--	Pass
01 (Peak)	2410.870	12.201	93.420	105.621	--	--	--
01 (Average)	2390.000	12.148	32.207	44.355	74.00	54.00	Pass
01 (Average)	2400.000	12.176	48.543	60.719	--	--	Pass
01 (Average)	2410.580	12.200	83.768	95.968	--	--	--

Figure Channel 01: Horizontal (Peak)

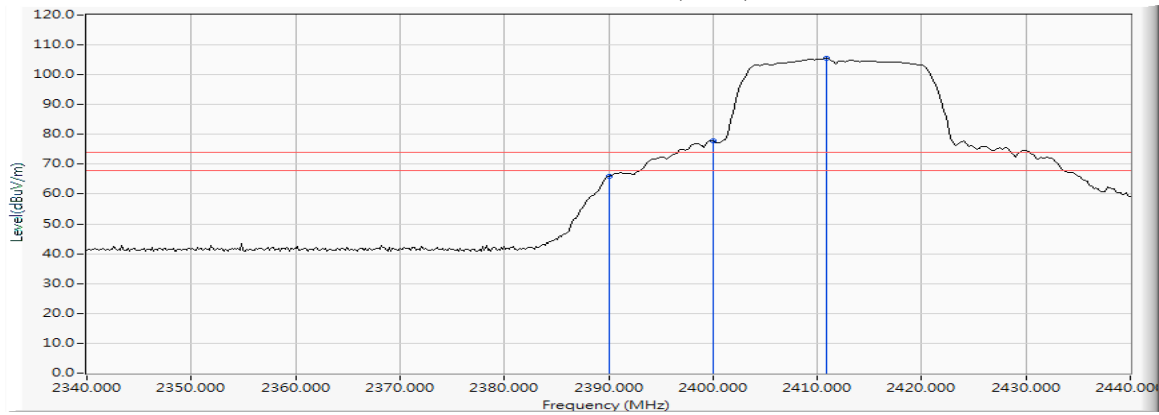
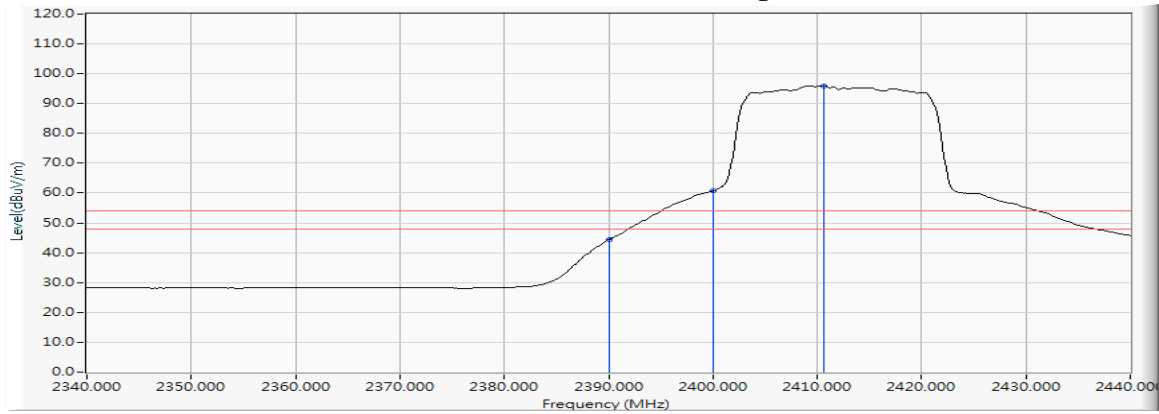

Figure Channel 01: Horizontal (Average)



Note:

1. All readings above 1GHz are performed with peak and/or average measurements as necessary.
2. Measurement Level = Reading Level + Correct Factor.
3. The average measurement was not performed when the peak measured data under the limit of average detection.

Product : Tablet PC
 Test Item : Band Edge Data
 Test Mode : Mode 3: Transmit (802.11n MCS0 7.2Mbps 20M-BW) (2412MHz)
 Test Date : 2018/01/16

RF Radiated Measurement (VERTICAL):

Channel No.	Frequency (MHz)	Correct Factor (dB)	Reading Level (dBμV)	Emission Level (dBμV/m)	Peak Limit (dBμV/m)	Average Limit (dBμV/m)	Result
01 (Peak)	2390.000	12.148	53.088	65.236	74.00	54.00	Pass
01 (Peak)	2400.000	12.176	65.891	78.067	--	--	Pass
01 (Peak)	2410.725	12.201	93.678	105.879	--	--	Pass
01 (Average)	2390.000	12.148	31.706	43.854	74.00	54.00	Pass
01 (Average)	2400.000	12.176	48.797	60.973	--	--	Pass
01 (Average)	2410.580	12.200	84.027	96.227	--	--	--

Figure Channel 01: VERTICAL (Peak)

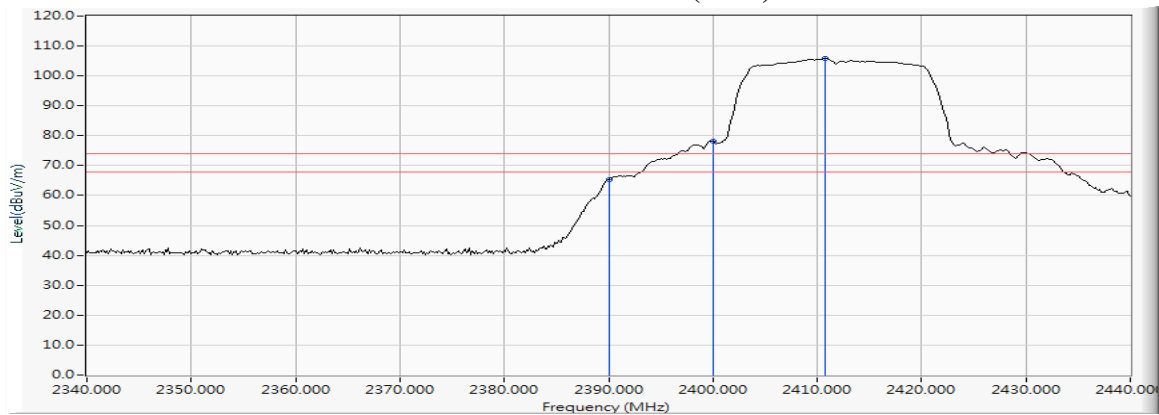
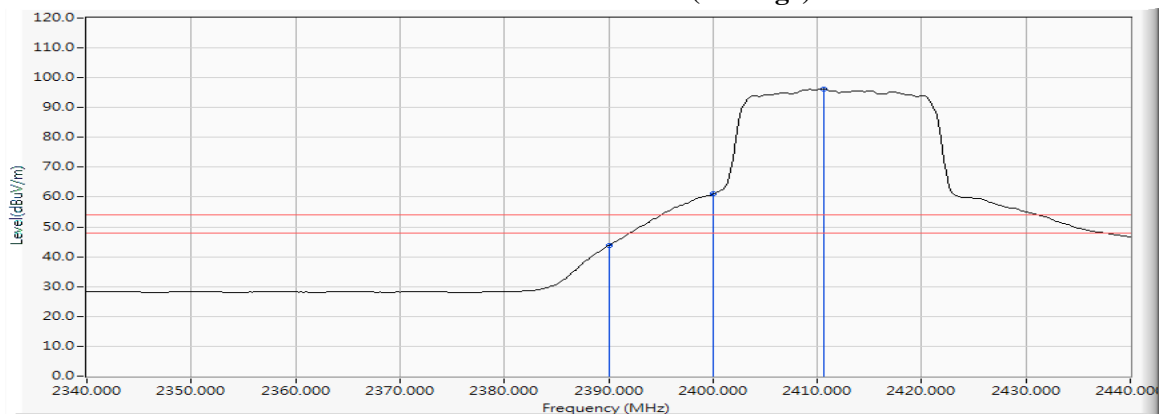

Figure Channel 01: VERTICAL (Average)



Note:

1. All readings above 1GHz are performed with peak and/or average measurements as necessary.
2. Measurement Level = Reading Level + Correct Factor.
3. The average measurement was not performed when the peak measured data under the limit of average detection.

Product : Tablet PC
 Test Item : Band Edge Data
 Test Mode : Mode 3: Transmit (802.11n MCS0 7.2Mbps 20M-BW) (2462MHz)
 Test Date : 2018/01/16

RF Radiated Measurement (Horizontal):

Channel No.	Frequency (MHz)	Correct Factor (dB)	Reading Level (dBμV)	Emission Level (dBμV/m)	Peak Limit (dBμV/m)	Average Limit (dBμV/m)	Result
11 (Peak)	2463.210	12.345	92.093	104.438	--	--	--
11 (Peak)	2483.500	12.403	47.082	59.485	74.00	54.00	Pass
11 (Average)	2463.500	12.345	82.650	94.996	--	--	--
11 (Average)	2483.500	12.403	30.616	43.019	74.00	54.00	Pass

Figure Channel 11: Horizontal (Peak)

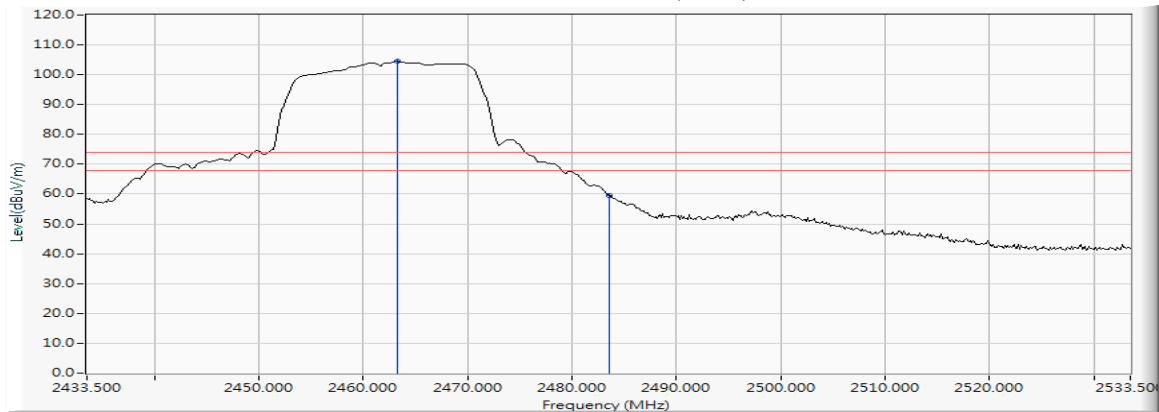
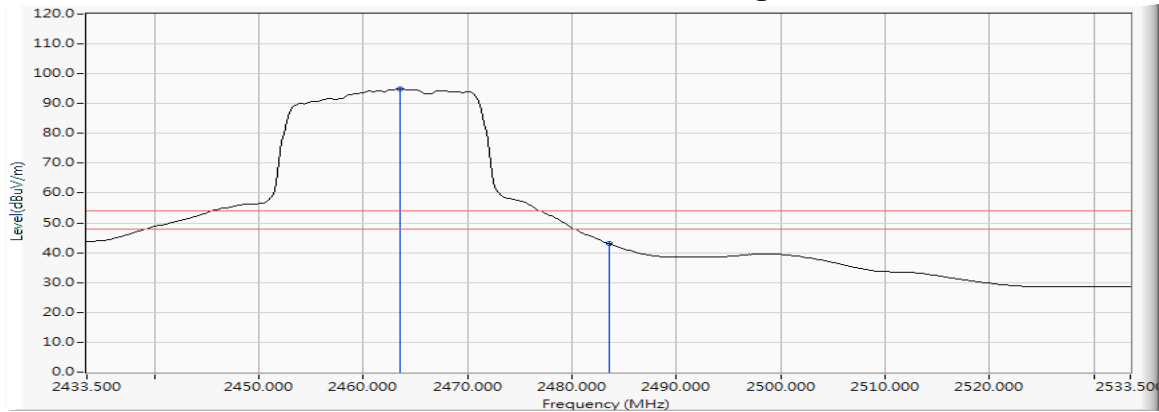

Figure Channel 11: Horizontal (Average)



Note:

1. All readings above 1GHz are performed with peak and/or average measurements as necessary.
2. Measurement Level = Reading Level + Correct Factor.
3. The average measurement was not performed when the peak measured data under the limit of average detection.

Product : Tablet PC
 Test Item : Band Edge Data
 Test Mode : Mode 3: Transmit (802.11n MCS0 7.2Mbps 20M-BW) (2462MHz)
 Test Date : 2018/01/16

RF Radiated Measurement (VERTICAL):

Channel No.	Frequency (MHz)	Correct Factor (dB)	Reading Level (dBμV)	Emission Level (dBμV/m)	Peak Limit (dBμV/m)	Average Limit (dBμV/m)	Result
11 (Peak)	2463.210	12.345	94.759	107.104	--	--	--
11 (Peak)	2483.500	12.403	50.177	62.580	74.00	54.00	Pass
11 (Average)	2463.500	12.345	85.321	97.667	--	--	--
11 (Average)	2483.500	12.403	33.479	45.882	74.00	54.00	Pass

Figure Channel 11: VERTICAL (Peak)

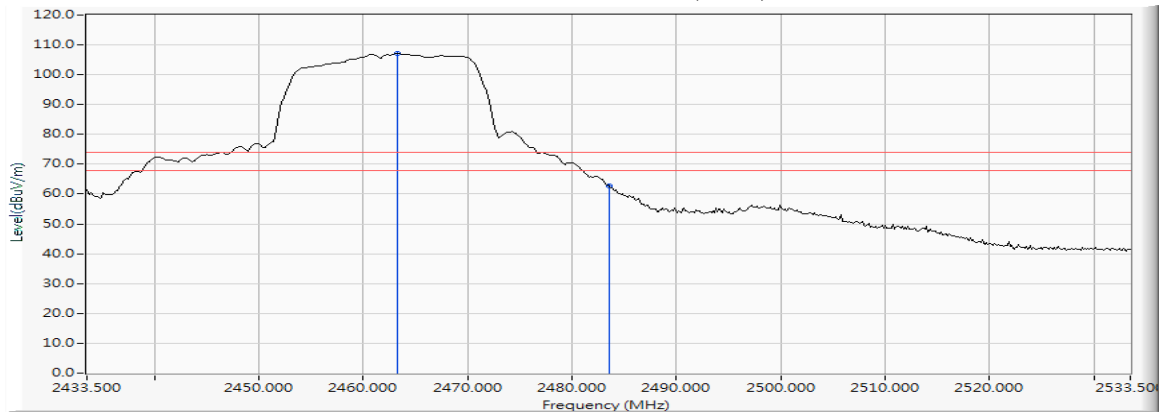
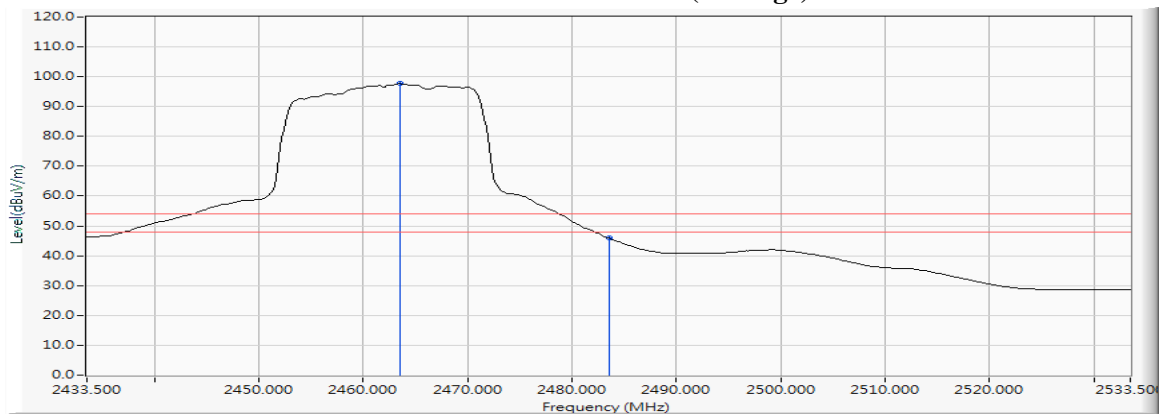

Figure Channel 11: VERTICAL (Average)



Note:

1. All readings above 1GHz are performed with peak and/or average measurements as necessary.
2. Measurement Level = Reading Level + Correct Factor.
3. The average measurement was not performed when the peak measured data under the limit of average detection.

Product : Tablet PC
 Test Item : Band Edge Data
 Test Mode : Mode 4: Transmit (802.11n MCS0 15Mbps 40M-BW) (2422MHz)
 Test Date : 2018/01/16

RF Radiated Measurement (Horizontal):

Channel No.	Frequency (MHz)	Correct Factor (dB)	Reading Level (dBμV)	Emission Level (dBμV/m)	Peak Limit (dBμV/m)	Average Limit (dBμV/m)	Result
03 (Peak)	2388.986	12.145	49.532	61.677	74.00	54.00	Pass
03 (Peak)	2390.000	12.148	45.985	58.133	74.00	54.00	Pass
03 (Peak)	2397.971	12.169	56.583	68.753	--	--	Pass
03 (Peak)	2400.000	12.176	55.646	67.822	--	--	Pass
03 (Peak)	2432.319	12.257	92.006	104.263	--	--	--
03 (Average)	2390.000	12.148	32.266	44.414	74.00	54.00	Pass
03 (Average)	2400.000	12.176	41.037	53.213	--	--	Pass
03 (Average)	2431.449	12.255	82.042	94.297	--	--	--

Figure Channel 03: Horizontal (Peak)

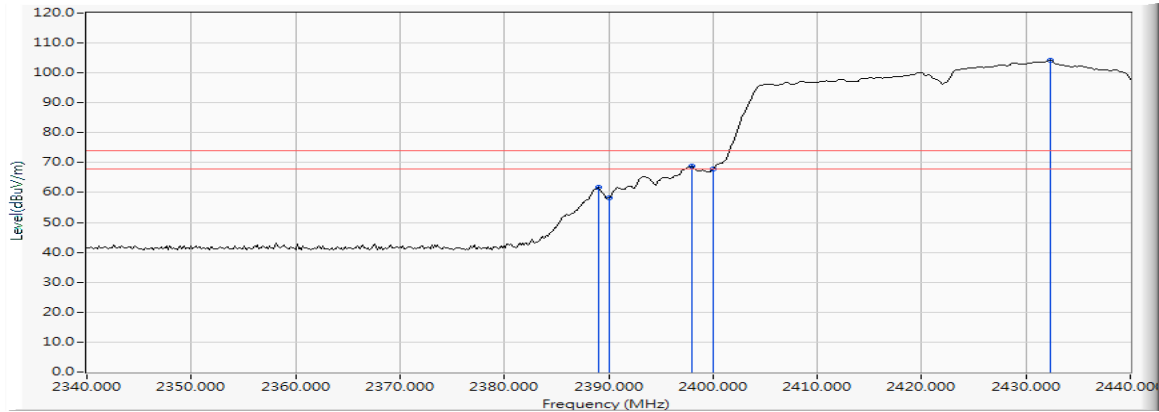
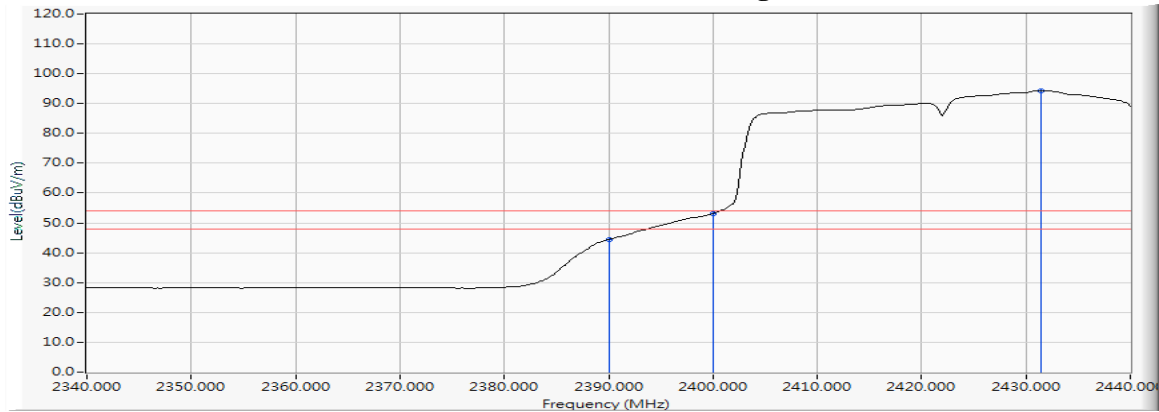

Figure Channel 03: Horizontal (Average)



Note:

1. All readings above 1GHz are performed with peak and/or average measurements as necessary.
2. Measurement Level = Reading Level + Correct Factor.
3. The average measurement was not performed when the peak measured data under the limit of average detection.

Product : Tablet PC
 Test Item : Band Edge Data
 Test Mode : Mode 4: Transmit (802.11n MCS0 15Mbps 40M-BW) (2422MHz)
 Test Date : 2018/01/16

RF Radiated Measurement (VERTICAL):

Channel No.	Frequency (MHz)	Correct Factor (dB)	Reading Level (dBμV)	Emission Level (dBμV/m)	Peak Limit (dBμV/m)	Average Limit (dBμV/m)	Result
03 (Peak)	2388.841	12.145	50.599	62.744	74.00	54.00	Pass
03 (Peak)	2390.000	12.148	47.217	59.365	74.00	54.00	Pass
03 (Peak)	2398.116	12.171	57.233	69.404	--	--	Pass
03 (Peak)	2400.000	12.176	56.376	68.552	--	--	Pass
03 (Peak)	2432.319	12.257	93.575	105.832	--	--	--
03 (Average)	2390.000	12.148	33.560	45.708	74.00	54.00	Pass
03 (Average)	2400.000	12.176	41.847	54.023	74.00	54.00	Pass
03 (Average)	2431.594	12.255	83.574	95.829	--	--	--

Figure Channel 03: VERTICAL (Peak)

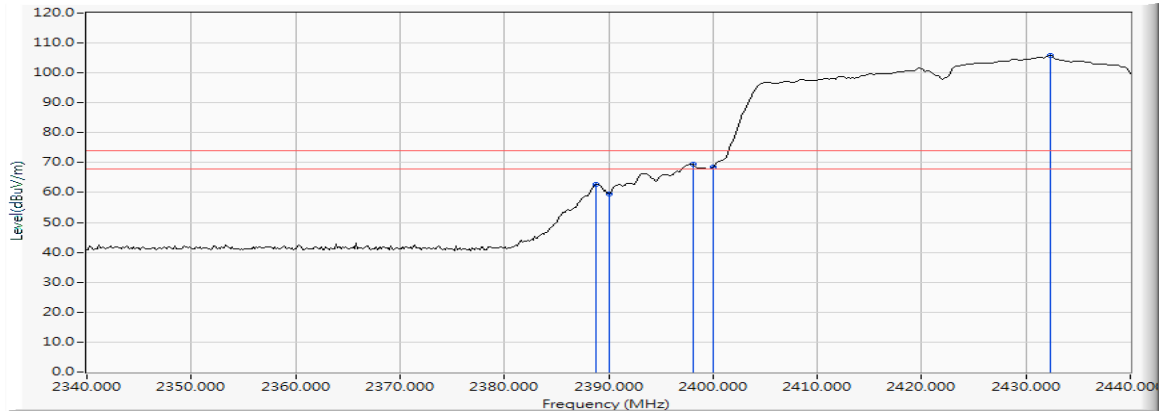
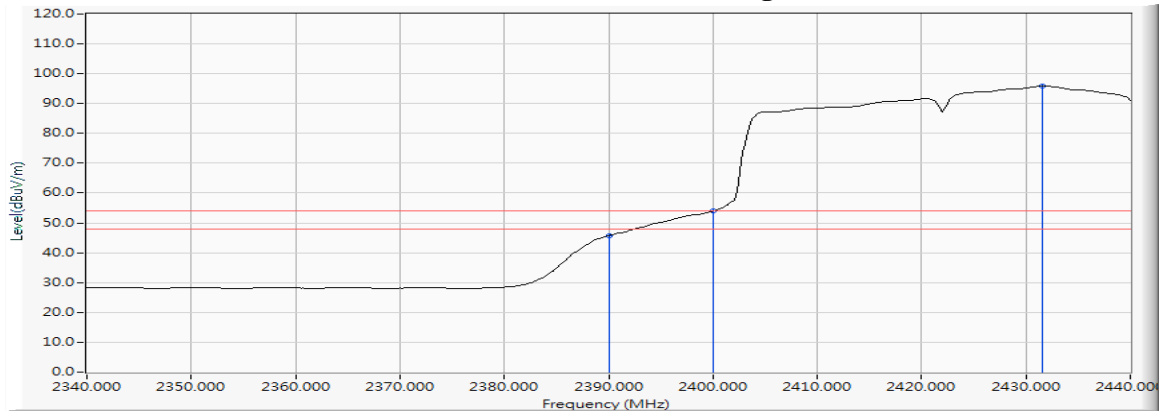

Figure Channel 03: VERTICAL (Average)



Note:

1. All readings above 1GHz are performed with peak and/or average measurements as necessary.
2. Measurement Level = Reading Level + Correct Factor.
3. The average measurement was not performed when the peak measured data under the limit of average detection.

Product : Tablet PC
 Test Item : Band Edge Data
 Test Mode : Mode 4: Transmit (802.11n MCS0 15Mbps 40M-BW) (2452MHz)
 Test Date : 2018/01/16

RF Radiated Measurement (Horizontal):

Channel No.	Frequency (MHz)	Correct Factor (dB)	Reading Level (dBμV)	Emission Level (dBμV/m)	Peak Limit (dBμV/m)	Average Limit (dBμV/m)	Result
09 (Peak)	2438.428	12.274	90.596	102.870	--	--	--
09 (Peak)	2483.500	12.403	51.946	64.349	74.00	54.00	Pass
09 (Average)	2438.283	12.274	81.078	93.352	--	--	--
09 (Average)	2483.500	12.403	35.625	48.028	74.00	54.00	Pass

Figure Channel 09: Horizontal (Peak)

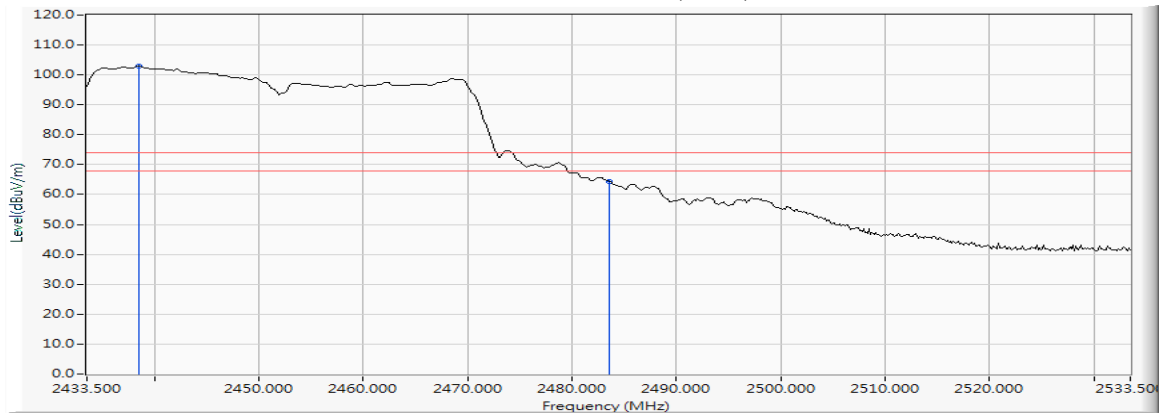
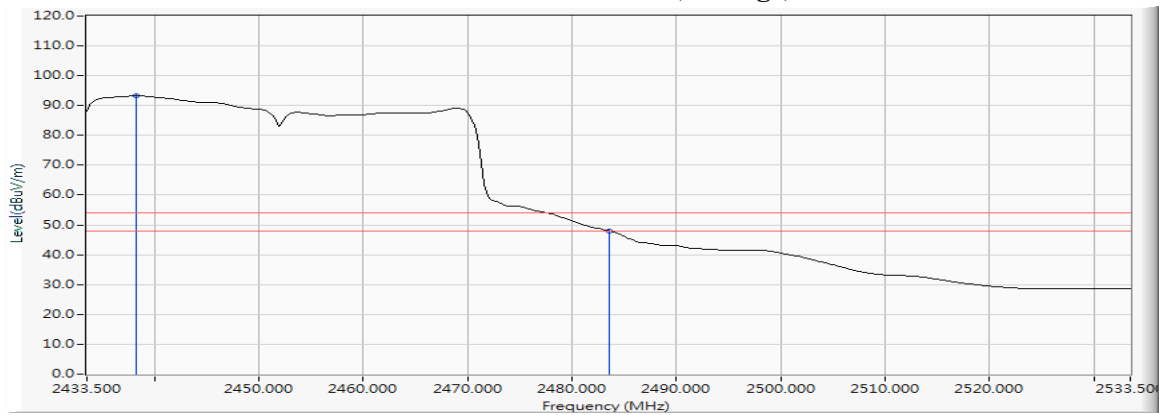

Figure Channel 09: Horizontal (Average)



Note:

1. All readings above 1GHz are performed with peak and/or average measurements as necessary.
2. Measurement Level = Reading Level + Correct Factor.
3. The average measurement was not performed when the peak measured data under the limit of average detection.

Product : Tablet PC
 Test Item : Band Edge Data
 Test Mode : Mode 4: Transmit (802.11n MCS0 15Mbps 40M-BW) (2452MHz)
 Test Date : 2018/01/16

RF Radiated Measurement (VERTICAL):

Channel No.	Frequency (MHz)	Correct Factor (dB)	Reading Level (dBμV)	Emission Level (dBμV/m)	Peak Limit (dBμV/m)	Average Limit (dBμV/m)	Result
09 (Peak)	2438.428	12.274	92.030	104.304	--	--	--
09 (Peak)	2483.500	12.403	54.603	67.006	74.00	54.00	Pass
09 (Average)	2438.138	12.273	82.521	94.794	--	--	--
09 (Average)	2483.500	12.403	38.246	50.649	74.00	54.00	Pass

Figure Channel 09: VERTICAL (Peak)

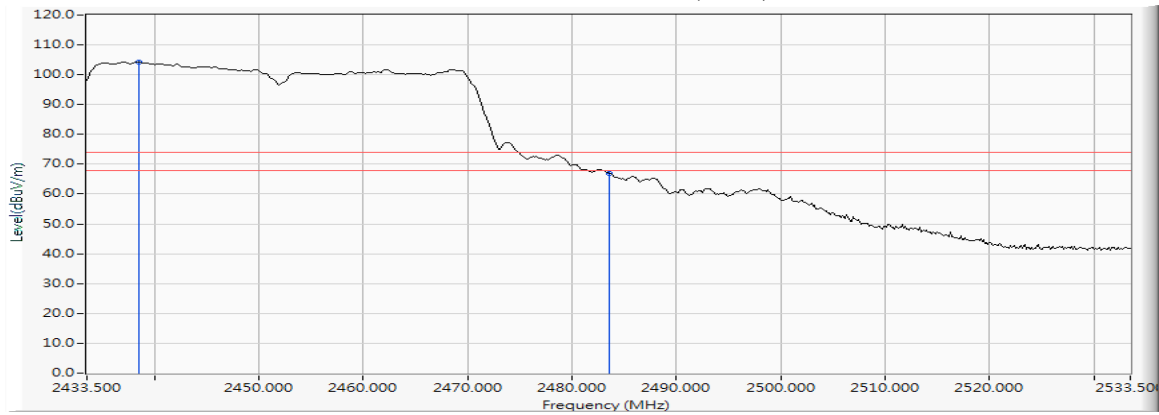
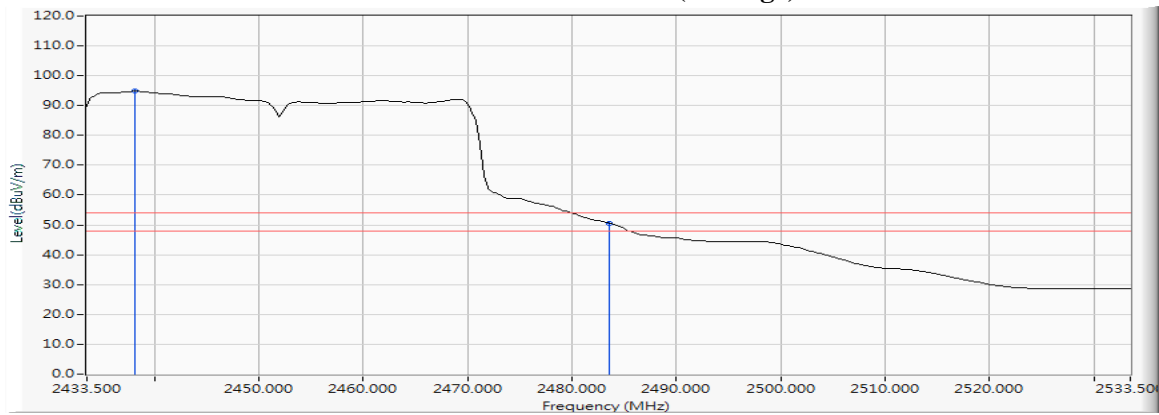

Figure Channel 09: VERTICAL (Average)



Note:

1. All readings above 1GHz are performed with peak and/or average measurements as necessary.
2. Measurement Level = Reading Level + Correct Factor.
3. The average measurement was not performed when the peak measured data under the limit of average detection.

7. 6dB Bandwidth

7.1. Test Setup

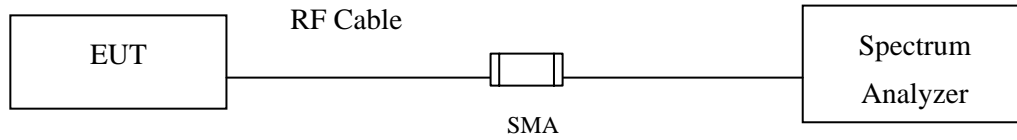

7.2. Limits

The minimum bandwidth shall be at least 500 kHz.

7.3. Test Procedure

The EUT was setup according to ANSI C63.4: 2014; tested according to DTS test procedure of Jan KDB558074 for compliance to FCC 47CFR 15.247 requirements.

7.4. Uncertainty

$\pm 279.2\text{Hz}$

7.5. Test Result of 6dB Bandwidth

Product : Tablet PC
 Test Item : 6dB Bandwidth Data
 Test Mode : Mode 1: Transmit (802.11b 1Mbps)

Channel No.	Frequency (MHz)	Measurement Level (kHz)	Required Limit (kHz)	Result
01	2412	9700	>500	Pass
06	2437	8650	>500	Pass
11	2462	8250	>500	Pass

Figure Channel 01:

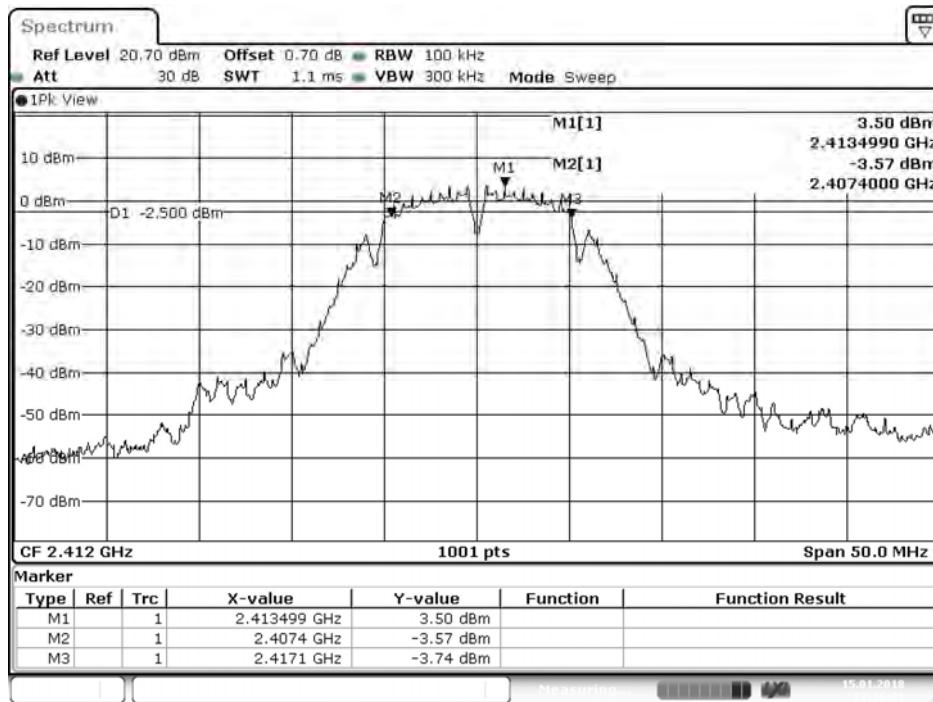

Date: 15. JAN 2018 13:36:22

Figure Channel 06:

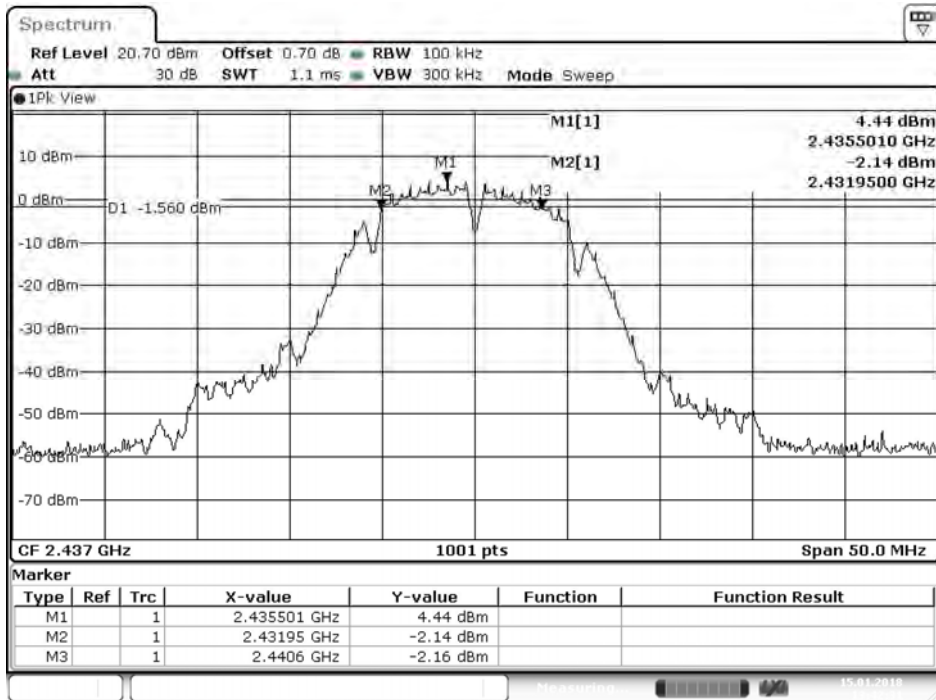

Date: 15. JAN. 2018 13:42:32

Figure Channel 11:

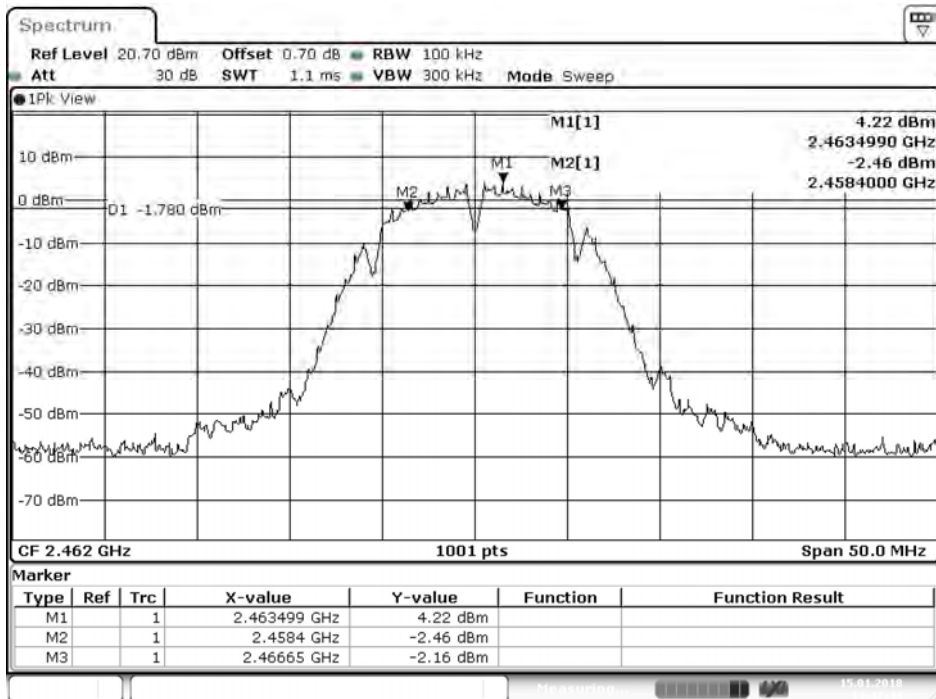

Date: 15. JAN. 2018 13:47:45

Product : Tablet PC
 Test Item : 6dB Bandwidth Data
 Test Mode : Mode 2: Transmit (802.11g 6Mbps)

Channel No.	Frequency (MHz)	Measurement Level (kHz)	Required Limit (kHz)	Result
01	2412	16600	>500	Pass
06	2437	14650	>500	Pass
11	2462	15200	>500	Pass

Figure Channel 01:

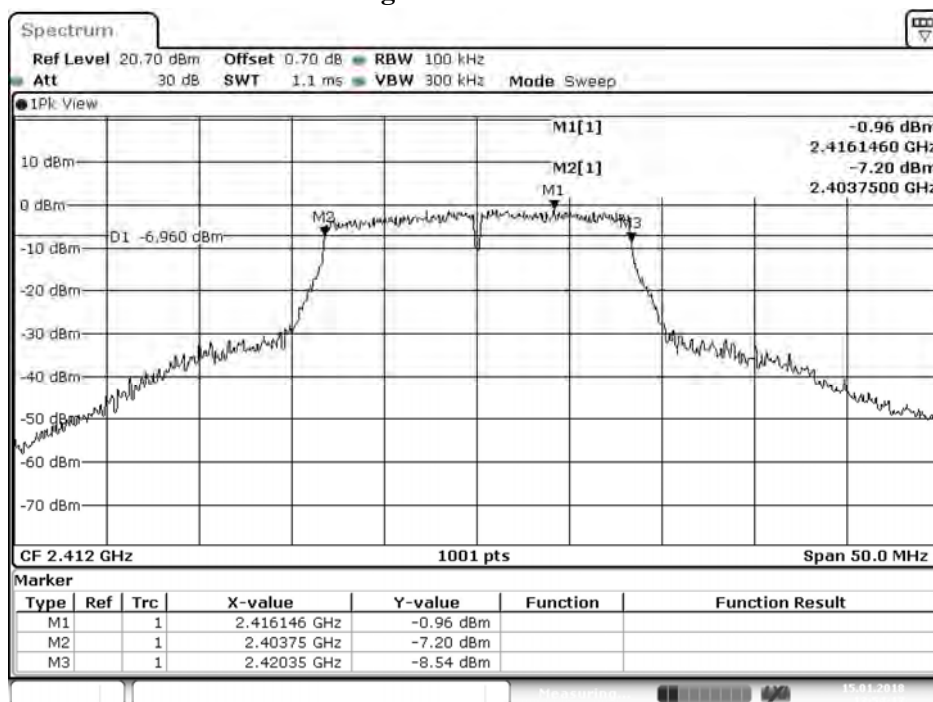

Date: 15.JAN.2018 13:54:17

Figure Channel 06:

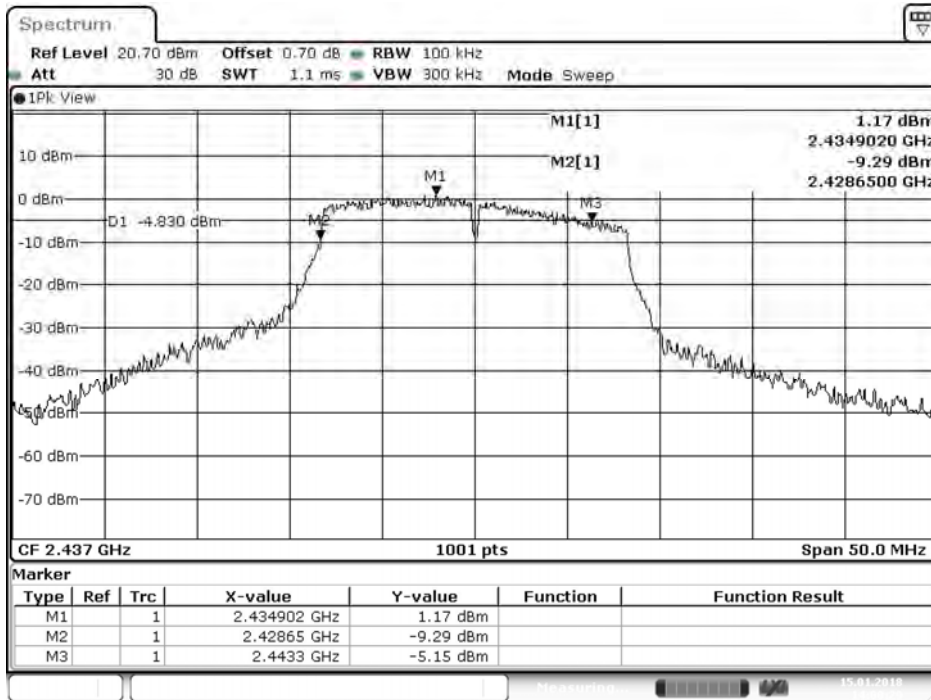

Date: 15. JAN 2018 14:00:30

Figure Channel 11:

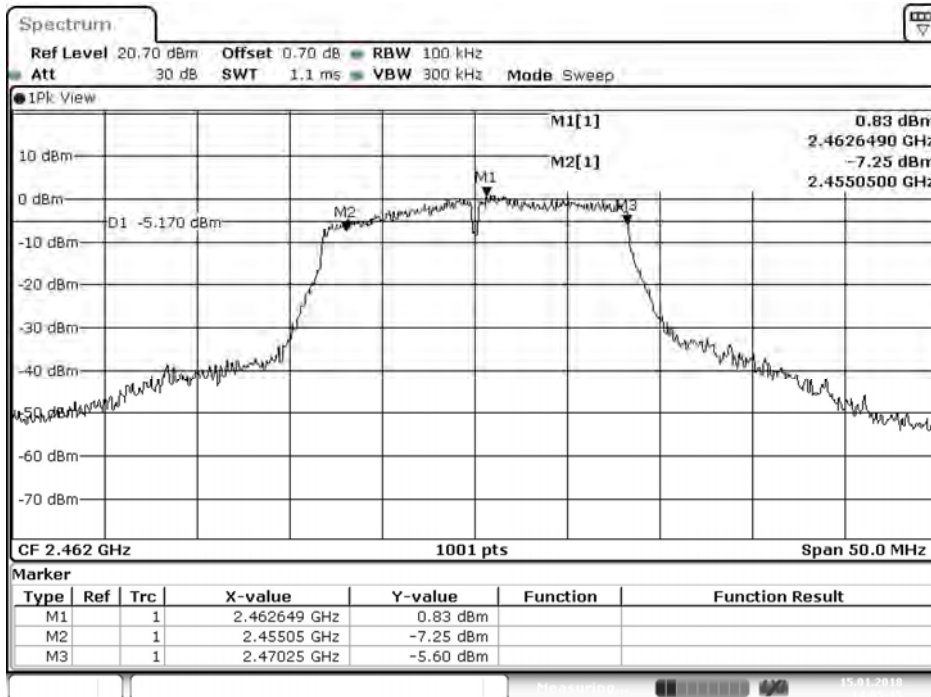

Date: 15. JAN 2018 14:05:15

Product : Tablet PC
 Test Item : 6dB Bandwidth Data
 Test Mode : Mode 3: Transmit (802.11n MCS0 7.2Mbps 20M-BW)

Channel No.	Frequency (MHz)	Measurement Level (kHz)	Required Limit (kHz)	Result
01	2412	17800	>500	Pass
06	2437	15550	>500	Pass
11	2462	16150	>500	Pass

Figure Channel 01:

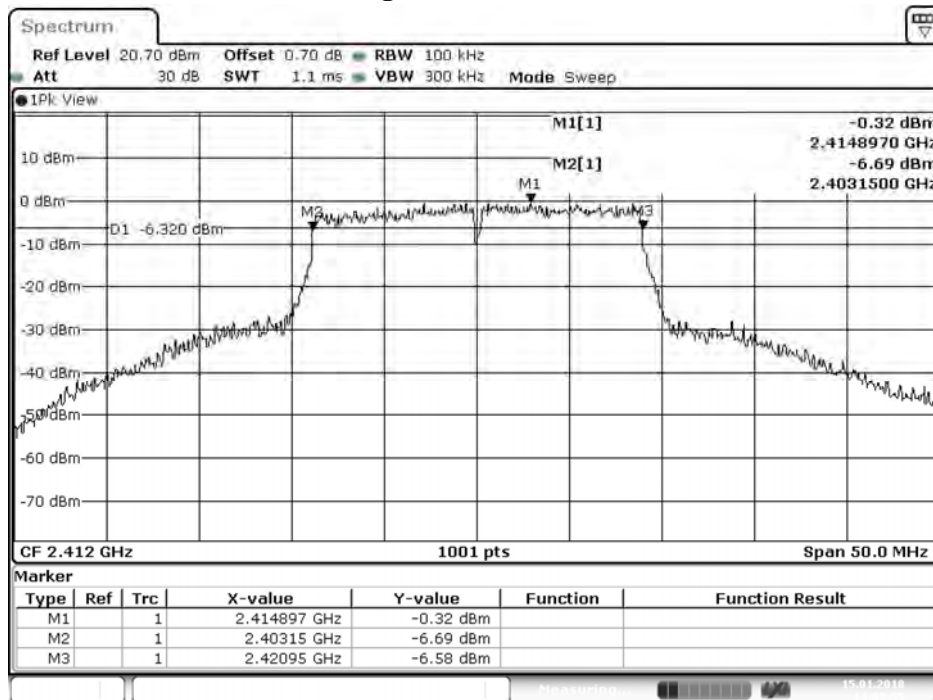

Date: 15.JAN.2018 14:09:56

Figure Channel 06:

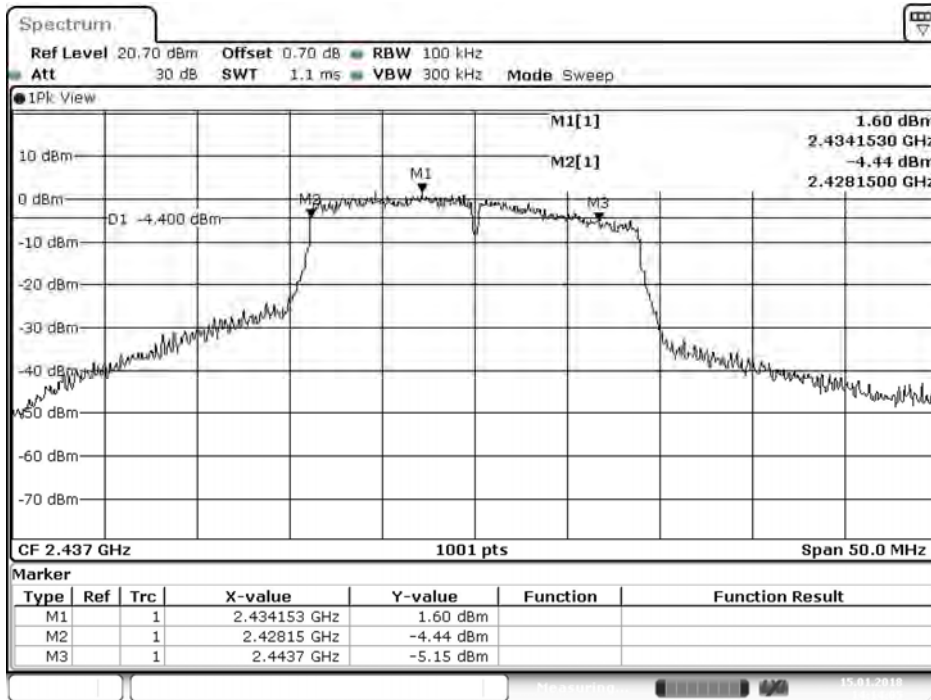

Date: 15. JAN 2018 14:14:06

Figure Channel 11:

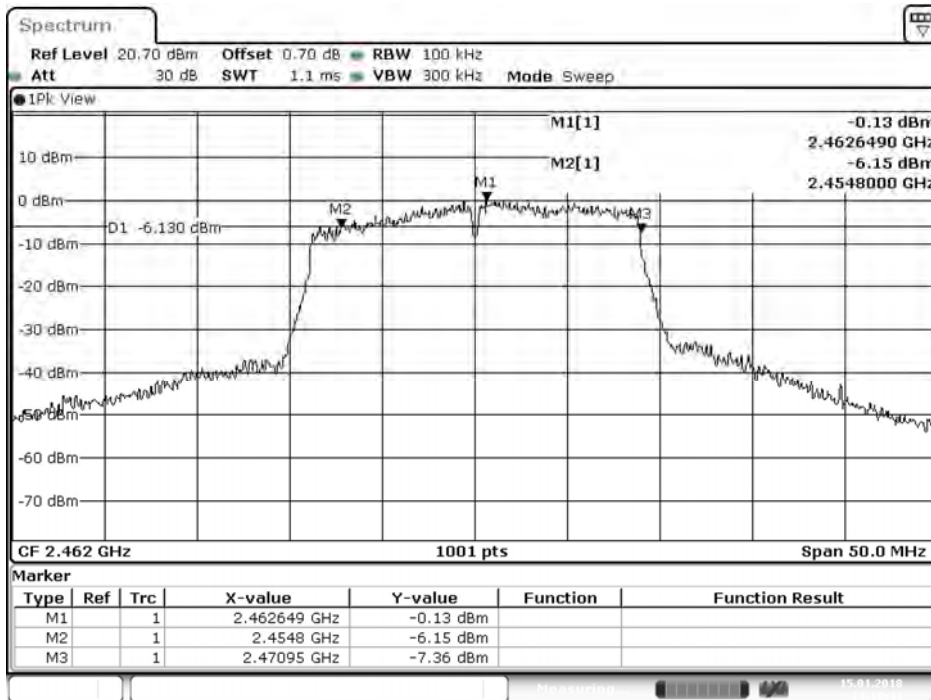

Date: 15. JAN 2018 14:18:43

Product : Tablet PC
 Test Item : 6dB Bandwidth Data
 Test Mode : Mode 4: Transmit (802.11n MCS0 15Mbps 40M-BW)

Channel No.	Frequency (MHz)	Measurement Level (kHz)	Required Limit (kHz)	Result
03	2422	25300	>500	Pass
06	2437	27200	>500	Pass
09	2452	36700	>500	Pass

Figure Channel 03:

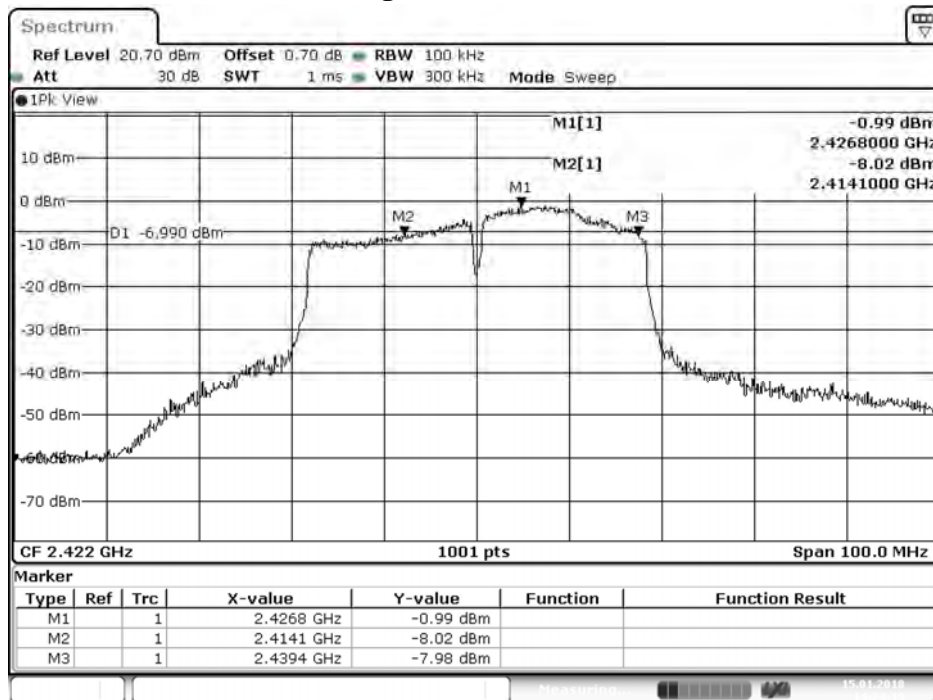

Date: 15.JAN.2018 14:24:19

Figure Channel 06:

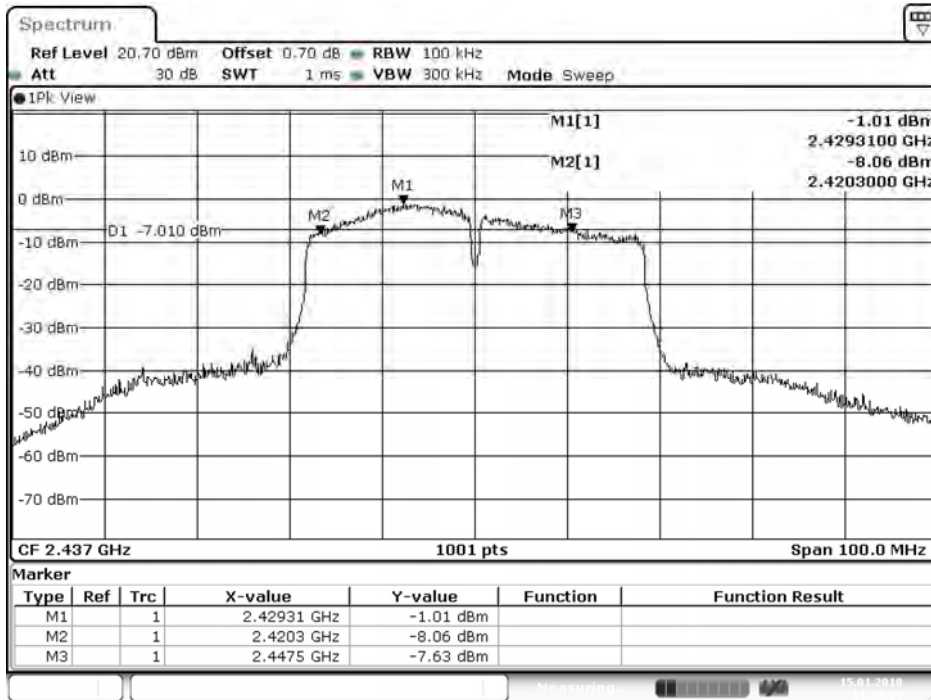

Date: 15. JAN 2018 14:29:09

Figure Channel 09:

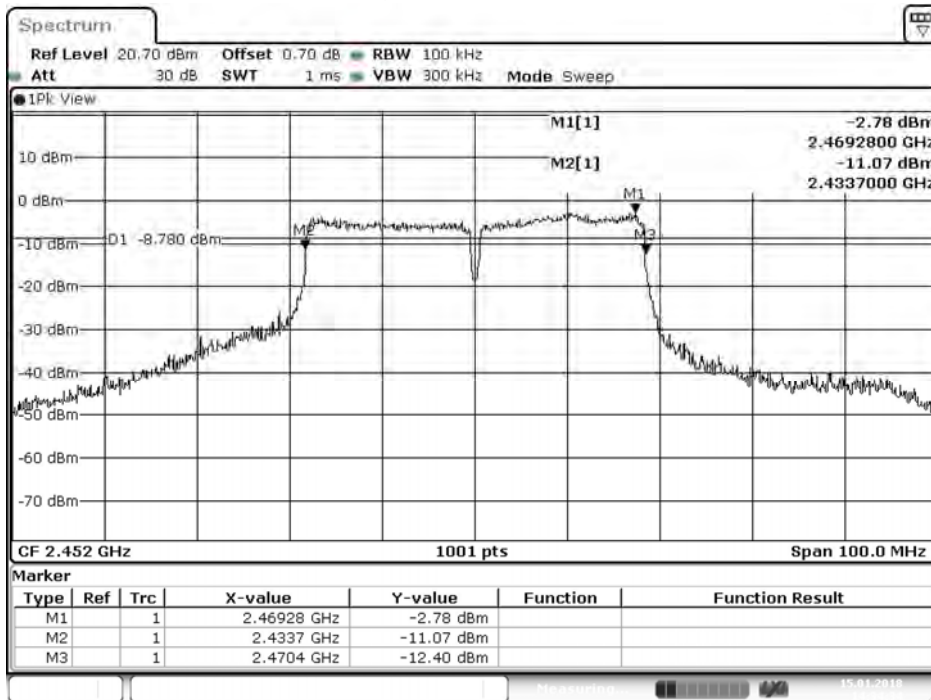

Date: 15. JAN 2018 14:34:34

8. Power Density

8.1. Test Setup

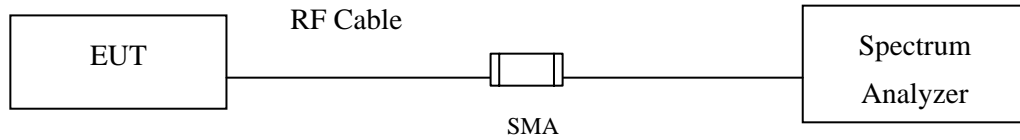

8.2. Limits

The transmitted power density averaged over any 1 second interval shall not be greater +8dBm in any 3kHz bandwidth.

8.3. Test Procedure

The EUT was setup according to ANSI C63.10, 2013; tested according to DTS test procedure of KDB 558074 for compliance to FCC 47CFR 15.247 requirements.

The maximum power spectral density using KDB 558074 section 10.2 PKPSD (peak PSD) method.

8.4. Uncertainty

± 1.23 dB

8.5. Test Result of Power Density

Product : Tablet PC
 Test Item : Power Density Data
 Test Mode : Mode 1: Transmit (802.11b 1Mbps)

Channel No.	Frequency (MHz)	Measure Level (dBm)	Limit (dBm)	Result
01	2412	3.410	≤ 8dBm	Pass
06	2437	4.360	≤ 8dBm	Pass
11	2462	4.110	≤ 8dBm	Pass

Figure Channel 01:

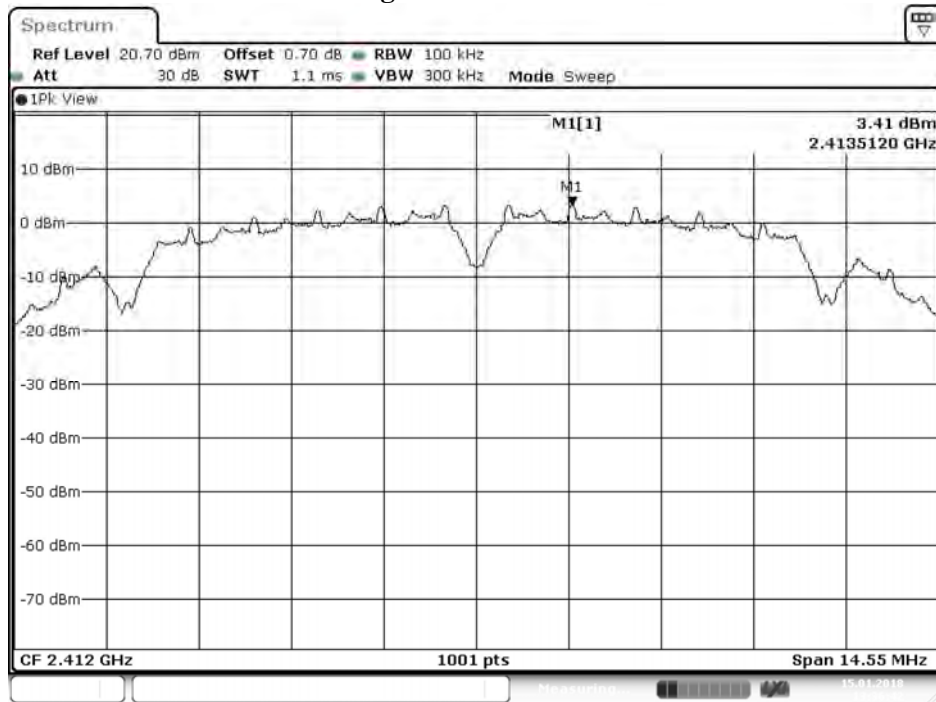

Date: 15. JAN. 2018 13:36:43

Figure Channel 06:

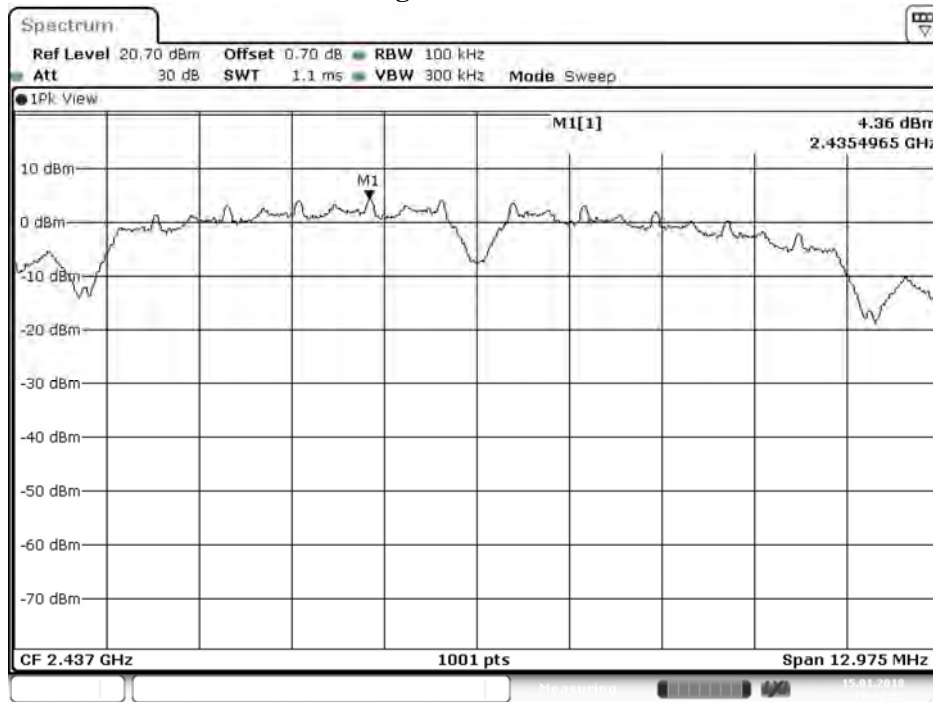

Date: 15. JAN. 2018 13:42:53

Figure Channel 11:

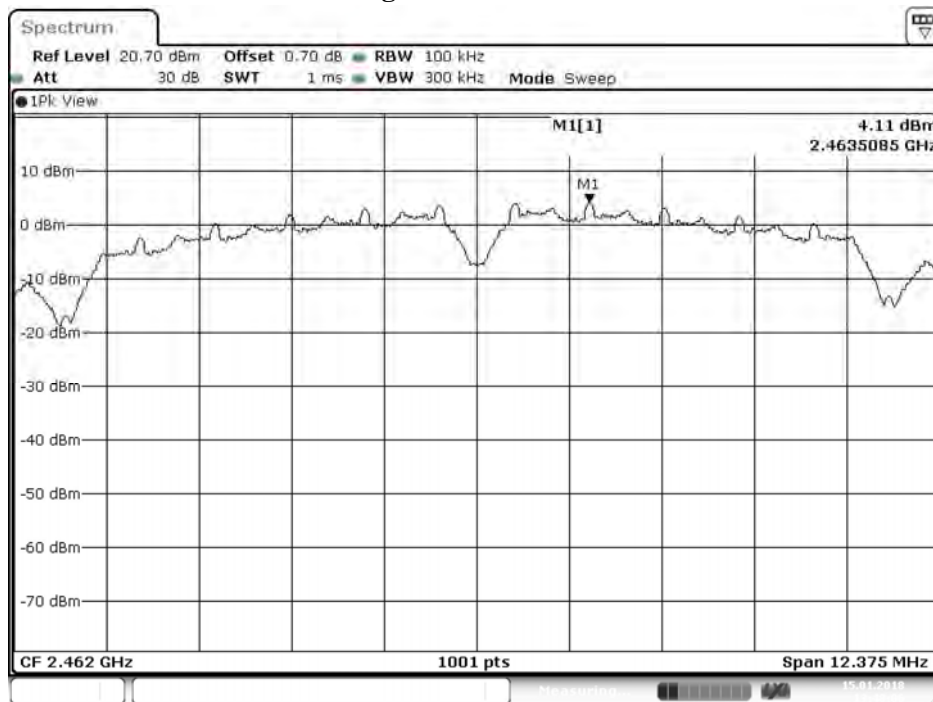

Date: 15. JAN. 2018 13:48:07

Product : Tablet PC
 Test Item : Power Density Data
 Test Mode : Mode 2: Transmit (802.11g 6Mbps)

Channel No.	Frequency (MHz)	Measure Level (dBm)	Limit (dBm)	Result
01	2412	-0.950	≤ 8dBm	Pass
06	2437	1.170	≤ 8dBm	Pass
11	2462	0.760	≤ 8dBm	Pass

Figure Channel 01:

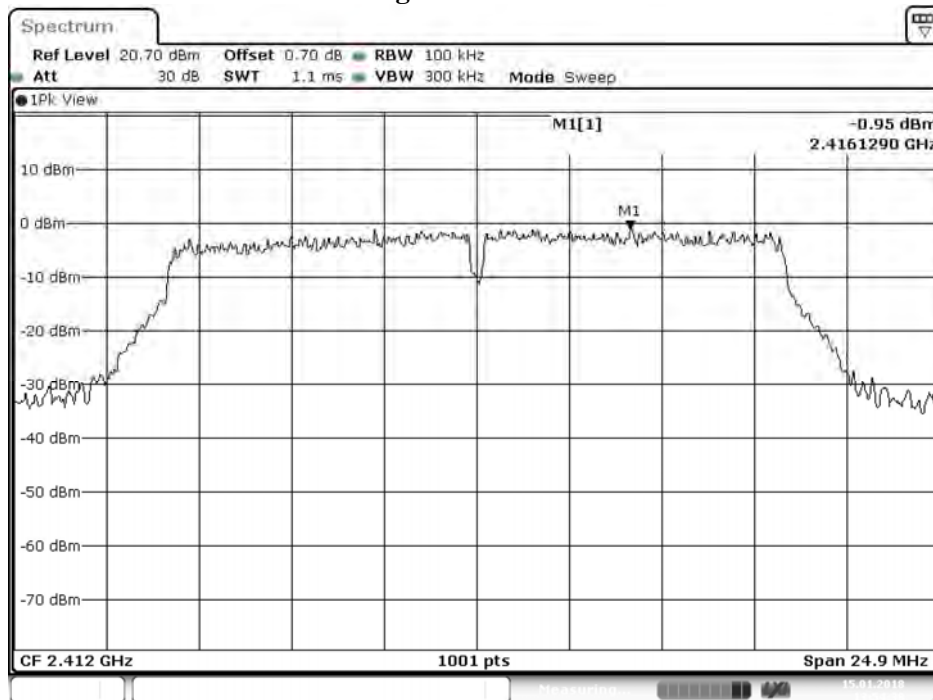

Date: 15. JAN 2018 13:54:39

Figure Channel 06:

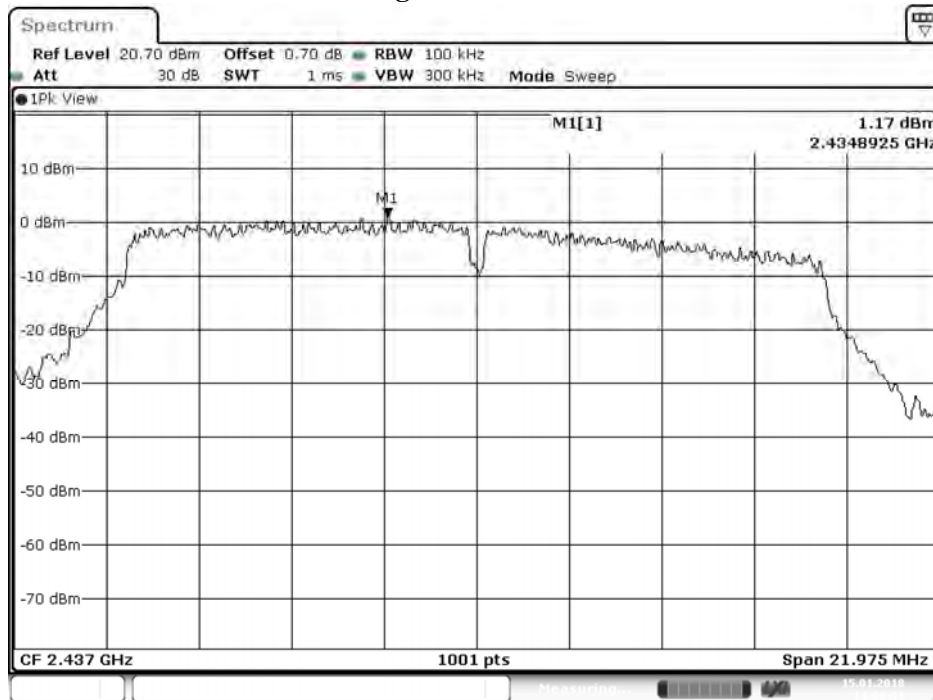

Date: 15. JAN. 2018 14:00:51

Figure Channel 11:

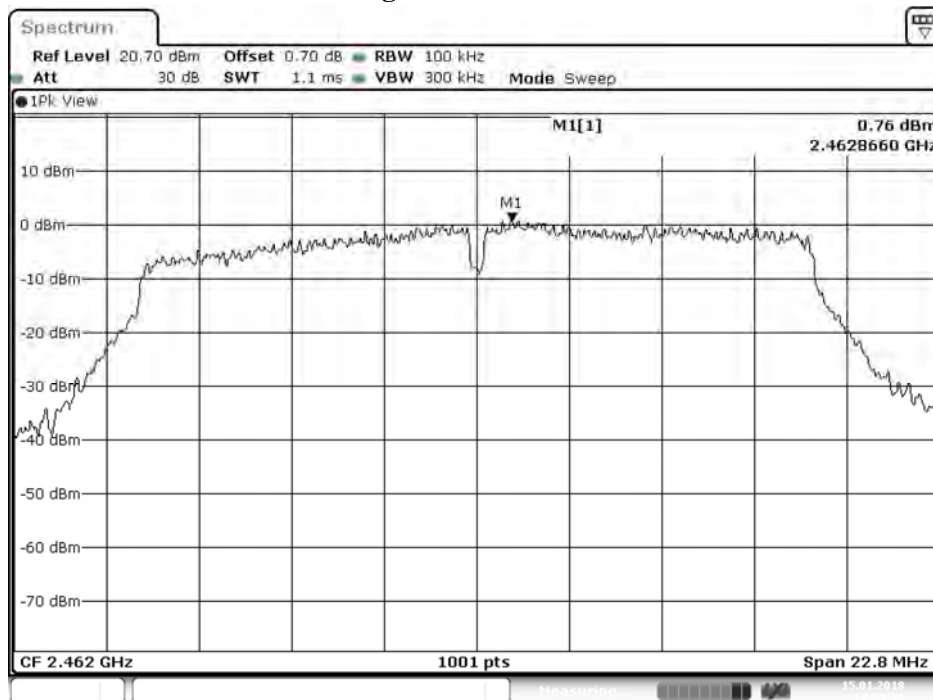

Date: 15. JAN. 2018 14:05:37

Product : Tablet PC
 Test Item : Power Density Data
 Test Mode : Mode 3: Transmit (802.11n MCS0 7.2Mbps 20M-BW)

Channel No.	Frequency (MHz)	Measure Level (dBm)	Limit (dBm)	Result
01	2412	-0.360	≤ 8dBm	Pass
06	2437	1.650	≤ 8dBm	Pass
11	2462	-0.070	≤ 8dBm	Pass

Figure Channel 01:

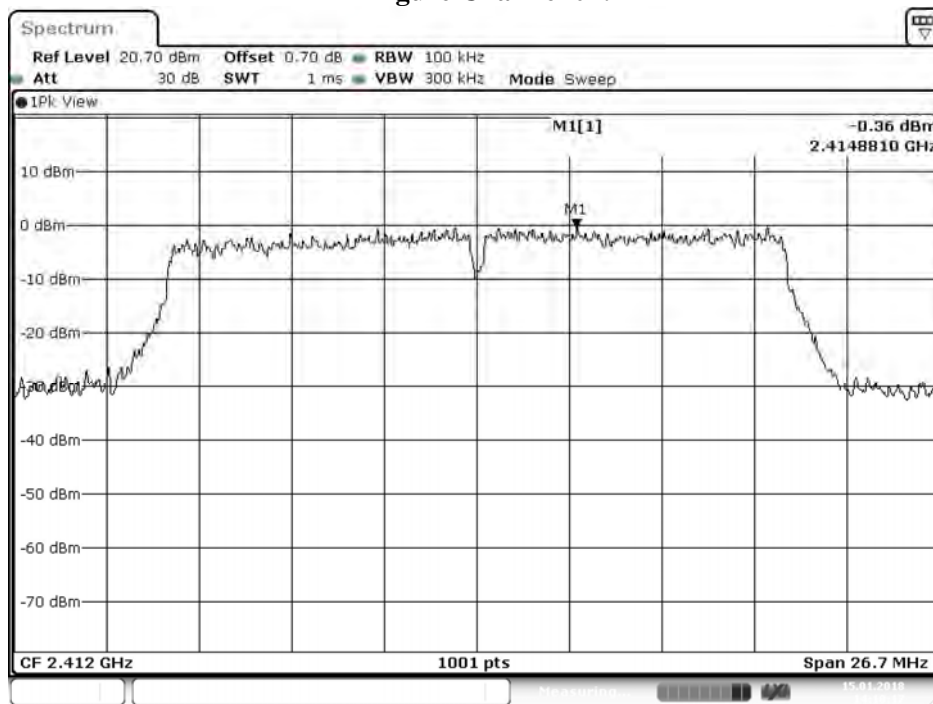

Date: 15. JAN. 2018 14:10:17

Figure Channel 06:

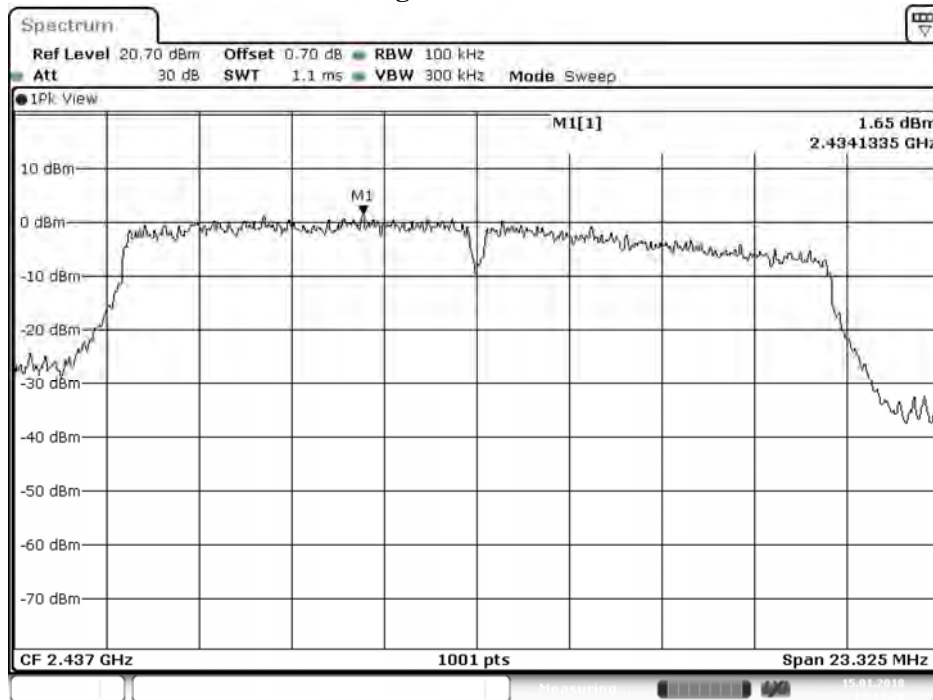

Date: 15. JAN. 2018 14:14:28

Figure Channel 11:

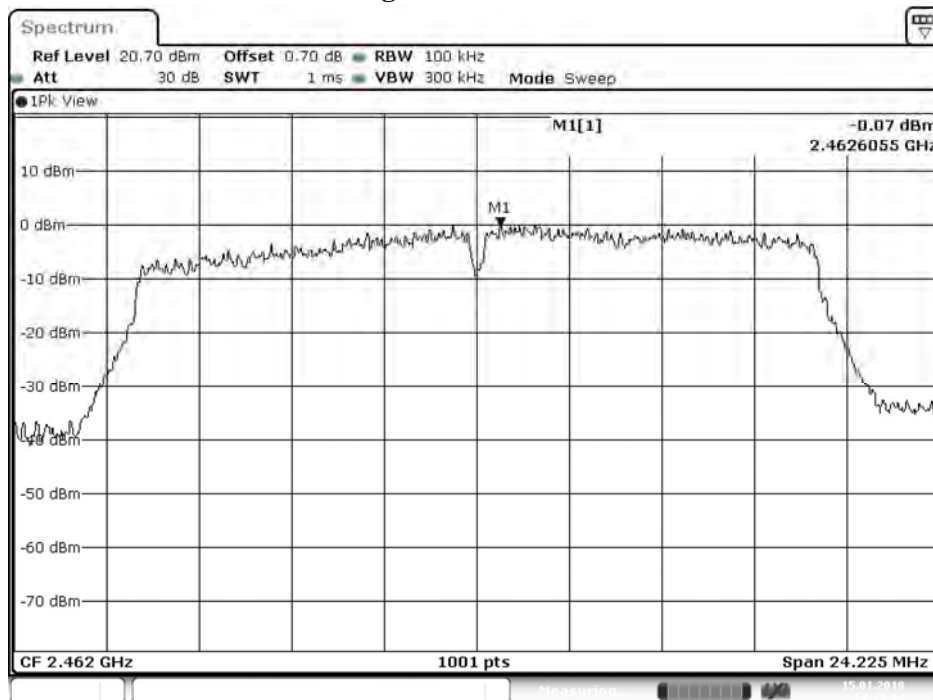

Date: 15. JAN. 2018 14:19:05

Product : Tablet PC
 Test Item : Power Density Data
 Test Mode : Mode 4: Transmit (802.11n MCS0 15Mbps 40M-BW)

Channel No.	Frequency (MHz)	Measure Level (dBm)	Limit (dBm)	Result
03	2422	-1.460	≤ 8dBm	Pass
06	2437	-1.200	≤ 8dBm	Pass
09	2452	-3.210	≤ 8dBm	Pass

Figure Channel 03:

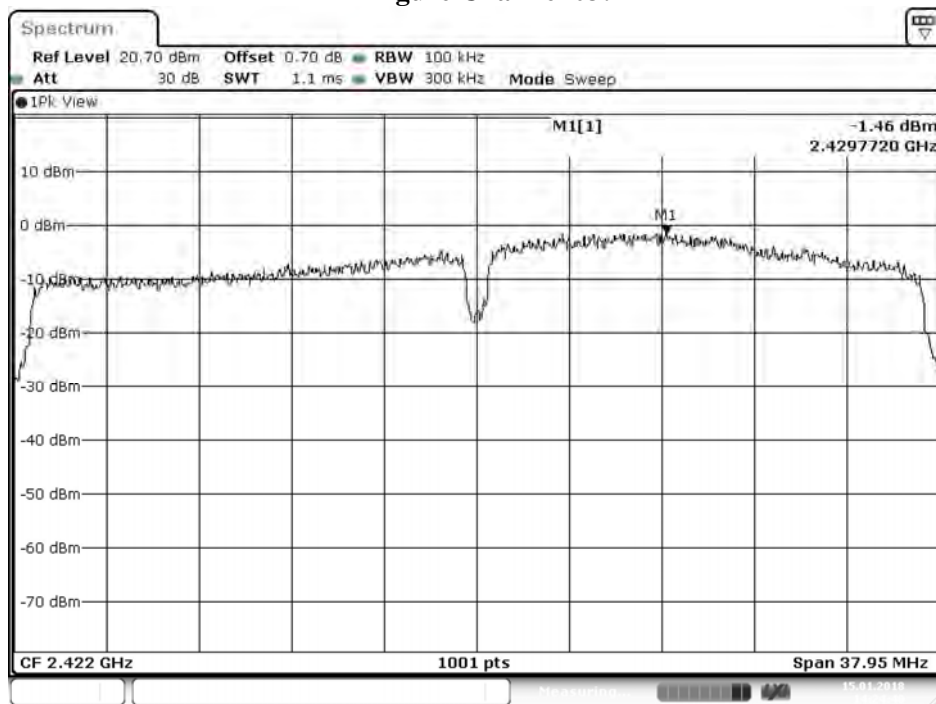

Date: 15. JAN. 2018 14:24:41

Figure Channel 06:

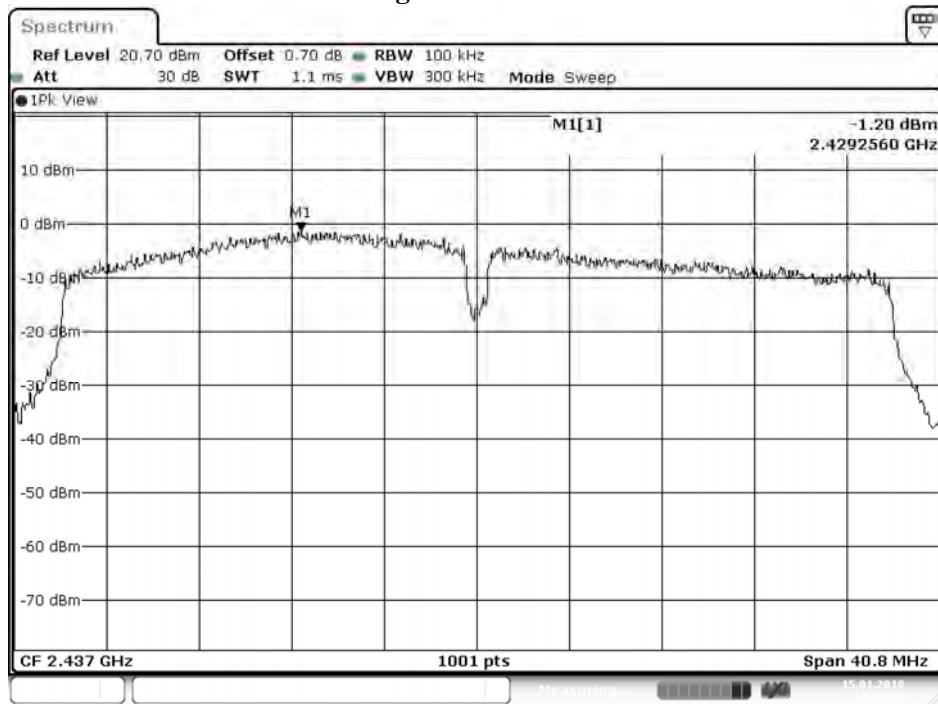

Date: 15. JAN. 2018 14:29:31

Figure Channel 09:

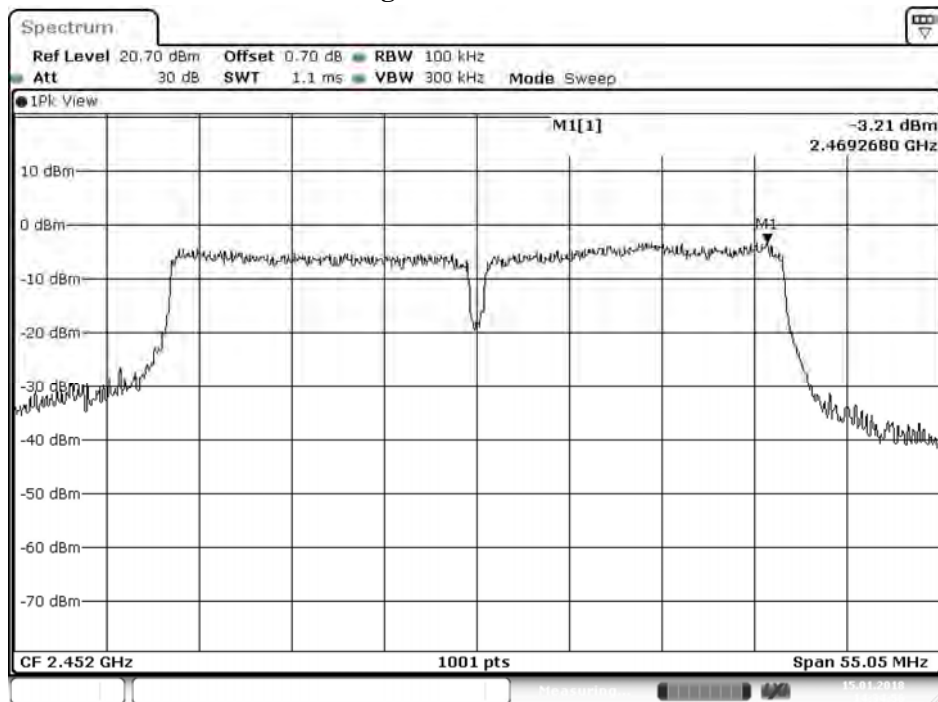

Date: 15. JAN. 2018 14:34:56

9. Duty Cycle

9.1. Test Setup

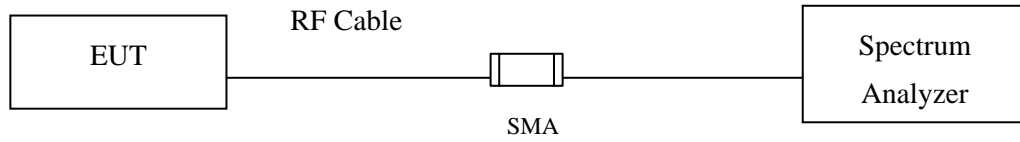

9.2. Test Procedure

The EUT was setup according to ANSI C63.10 2013; tested according to DTS test procedure of KDB558074 for compliance to FCC 47CFR 15.247 requirements.

9.3. Uncertainty

$\pm 2.31\text{msec}$

9.4. Test Result of Duty Cycle

Product : Tablet PC
 Test Item : Duty Cycle
 Test Mode : Transmit

Duty Cycle Formula:

$$\text{Duty Cycle} = \text{Ton} / (\text{Ton} + \text{Toff})$$

$$\text{Duty Factor} = 10 \text{ Log} (1/\text{Duty Cycle})$$

Results:

2.4GHz band	Ton (ms)	Ton + Toff (ms)	Duty Cycle (%)	Duty Factor (dB)
802.11b	--	--	100.00	0.00
802.11g	--	--	100.00	0.00
802.11n20	--	--	100.00	0.00
802.11n40	--	--	100.00	0.00

802.11b

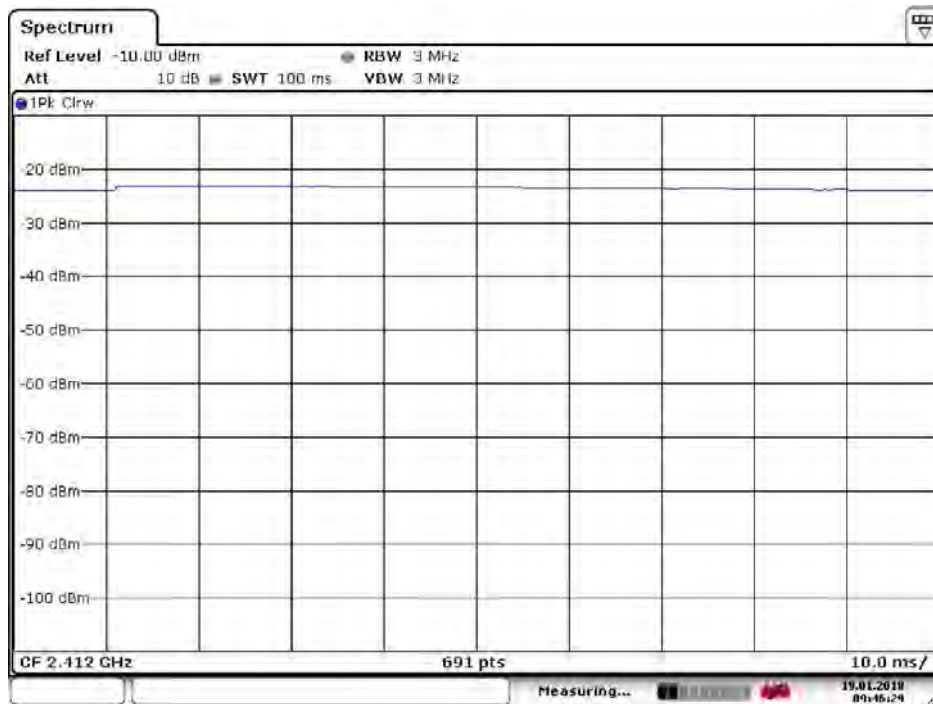

Date: 19 JAN 2018 09:46:30

802.11g

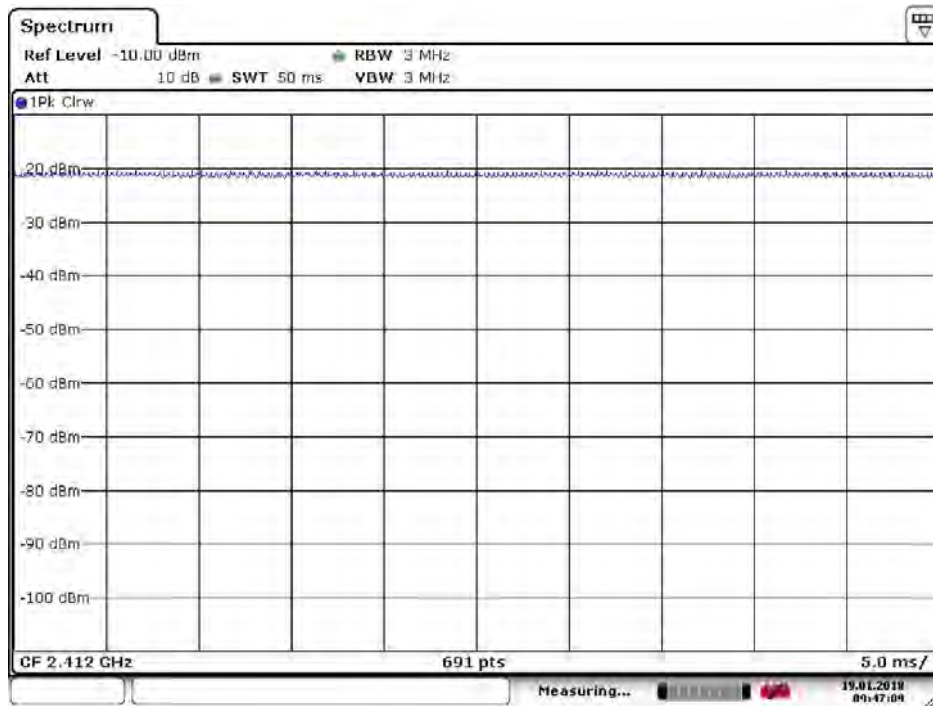

Date: 19. JAN. 2018 09:47:09

802.11n20

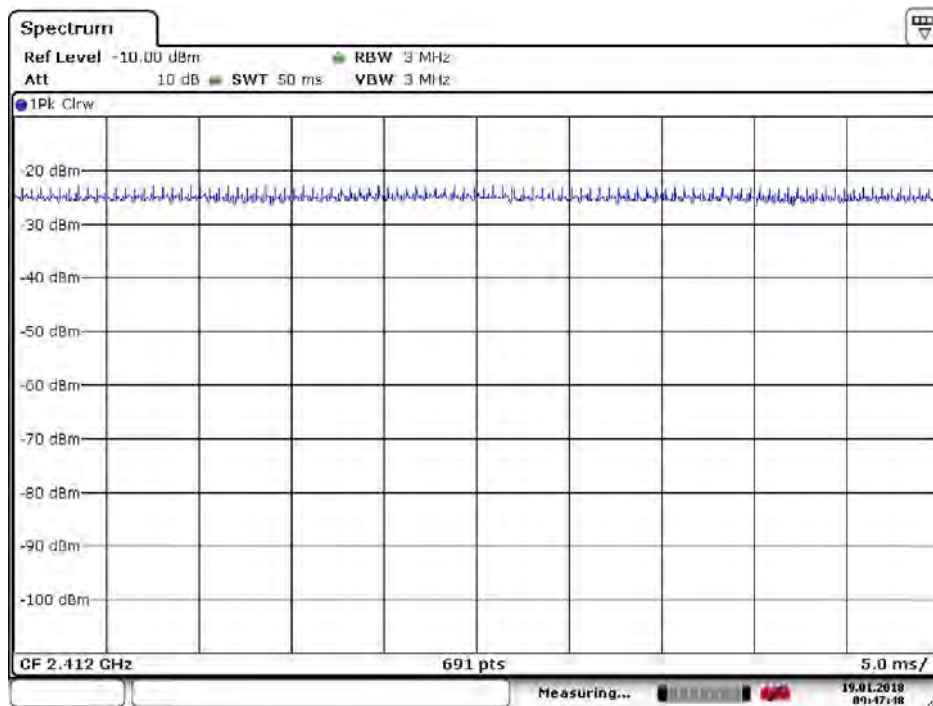

Date: 19. JAN. 2018 09:47:18

802.11n40

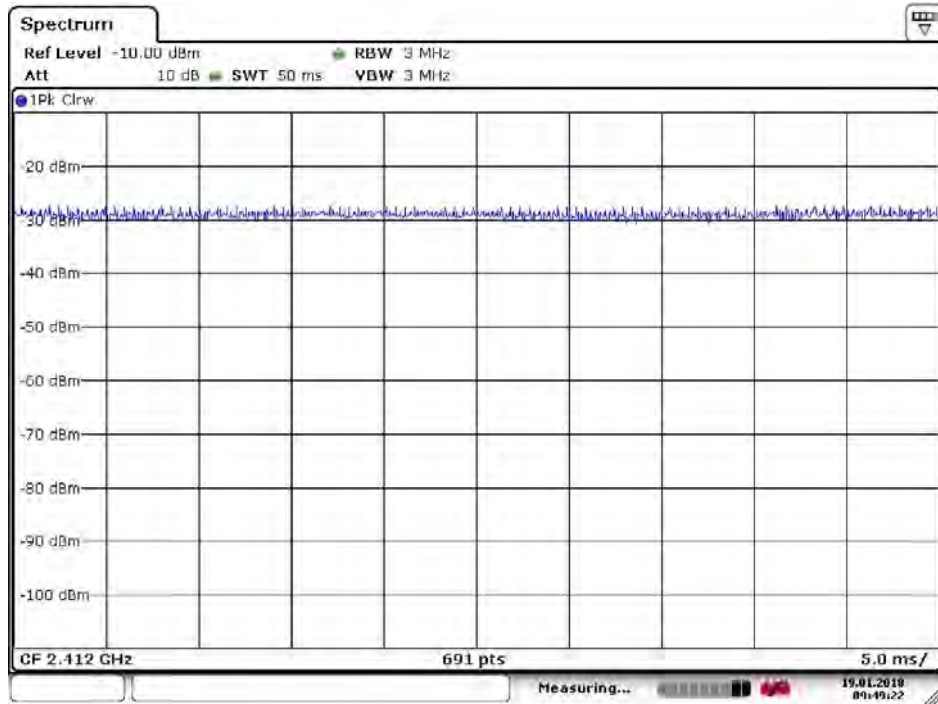

Date: 19. JAN 2018 09:49:22

10. EMI Reduction Method During Compliance Testing

No modification was made during testing.