

FCC Test Report

Product Name	Tablet PC
Model No.	TU10MK, TF10MK1, Ty10MKx(y=0~9, A~Z or blank or “-”, x=0~9, A~Z or blank or “-”)
FCC ID.	WL6-TU1MT63MK1

Applicant	ELITEGROUP COMPUTER SYSTEMS CO., LTD
Address	No.239, Sec. 2, Ti Ding Blvd., Taipei, Taiwan

Date of Receipt	Dec. 15, 2017
Issued Date	Jan. 26, 2018
Report No.	17C0206R-RFUSP01V00
Report Version	V1.0



The test results relate only to the samples tested.

The test results shown in the test report are traceable to the national/international standard through the calibration report of the equipment and evaluated measurement uncertainty herein.

This report must not be used to claim product endorsement by TAF or any agency of the government.

The test report shall not be reproduced without the written approval of DEKRA Testing and Certification Co., Ltd.

Test Report

Issued Date: Jan. 26, 2018

Report No.: 17C0206R-RFUSP01V00



Product Name	Tablet PC
Applicant	ELITEGROUP COMPUTER SYSTEMS CO., LTD
Address	No.239, Sec. 2, Ti Ding Blvd., Taipei, Taiwan
Manufacturer	ELITEGROUP COMPUTER SYSTEMS CO., LTD
Model No.	TU10MK, TF10MK1, Ty10MKx(y=0~9, A~Z or blank or "-", x=0~9, A~Z or blank or "-")
FCC ID.	WL6-TU1MT63MK1
EUT Rated Voltage	AC 100-240V, 50-60Hz or DC 3.7V(Power by battery)
EUT Test Voltage	AC 120V/60Hz
Trade Name	ECS ELITEGROUP
Applicable Standard	FCC CFR Title 47 Part 15 Subpart C: 2016 ANSI C63.4: 2014, ANSI C63.10: 2013
Test Result	Complied

Documented By :

Jinn Chen

(Senior Adm. Specialist / Jinn Chen)

Tested By :

Steven Tsai

(Assistant Engineer / Steven Tsai)

Approved By :

Vincent Lin

(Director / Vincent Lin)

TABLE OF CONTENTS

Description	Page
1. GENERAL INFORMATION	5
1.1. EUT Description.....	5
1.2. Operational Description.....	7
1.3. Tested System Details.....	8
1.4. Configuration of Tested System	8
1.5. EUT Exercise Software	9
1.6. Test Facility	10
1.7. List of Test Equipment.....	11
2. CONDUCTED EMISSION	12
2.1. Test Setup	12
2.2. Limits.....	12
2.3. Test Procedure	13
2.4. Uncertainty	13
2.5. Test Result of Conducted Emission.....	14
3. PEAK POWER OUTPUT	16
3.1. Test Setup	16
3.2. Limit	16
3.3. Test Procedure	16
3.4. Uncertainty	16
3.5. Test Result of Peak Power Output.....	17
4. RADIATED EMISSION	19
4.1. Test Setup	19
4.2. Limits.....	20
4.3. Test Procedure	21
4.4. Uncertainty	21
4.5. Test Result of Radiated Emission.....	22
5. RF ANTENNA CONDUCTED TEST	30
5.1. Test Setup	30
5.2. Limits.....	30
5.3. Test Procedure	30
5.4. Uncertainty	30
5.5. Test Result of RF Antenna Conducted Test.....	31
6. BAND EDGE	33
6.1. Test Setup	33
6.2. Limit	34
6.3. Test Procedure	34
6.4. Uncertainty	34
6.5. Test Result of Band Edge	35
7. CHANNEL NUMBER.....	47
7.1. Test Setup	47
7.2. Limit	47
7.3. Test Procedure	47
7.4. Uncertainty	47
7.5. Test Result of Channel Number.....	48
8. CHANNEL SEPARATION.....	50
8.1. Test Setup	50
8.2. Limit	50
8.3. Test Procedure	50
8.4. Uncertainty	50
8.5. Test Result of Channel Separation.....	51
9. DWELL TIME.....	55
9.1. Test Setup	55
9.2. Limit	55
9.3. Test Procedure	55
9.4. Uncertainty	55
9.5. Test Result of Dwell Time.....	56
10. OCCUPIED BANDWIDTH	60
10.1. Test Setup	60

10.2.	Limits.....	60
10.3.	Test Procedure	60
10.4.	Uncertainty	60
10.5.	Test Result of Occupied Bandwidth	61
11.	EMI REDUCTION METHOD DURING COMPLIANCE TESTING	65
Attachment 1: EUT Test Photographs		
Attachment 2: EUT Detailed Photographs		

1. GENERAL INFORMATION

1.1. EUT Description

Product Name	Tablet PC
Trade Name	ECS ELITEGROUP
Model No.	TU10MK, TF10MK1, Ty10MKx(y=0~9, A~Z or blank or “-”, x=0~9, A~Z or blank or “-”)
FCC ID.	WL6-TU1MT63MK1
Frequency Range	2402 – 2480MHz
Channel Number	79
Type of Modulation	FHSS: GFSK(1Mbps) / π / 4DQPSK(2Mbps) / 8DPSK(3Mbps)
Antenna Type	PIFA Antenna
Channel Control	Auto
Antenna Gain	Refer to the table “Antenna List”
Power Adapter	MFR: Asian, M/N:WB-10E05R Input:100-240V~50-60Hz, 0.4A Output:5V $\overline{\text{---}}$, 2A Cable Out Non-shielded, 1.5m

Antenna List

No.	Manufacturer	Part No.	Antenna Type	Peak Gain
1	WGT	13-130-JL5050	PIFA Antenna	2.98 dBi for 2.4 GHz

Note: The antenna of EUT is conforming to FCC 15.203.

Center Frequency of Each Channel:

Channel	Frequency	Channel	Frequency	Channel	Frequency	Channel	Frequency
Channel 00:	2402 MHz	Channel 20:	2422 MHz	Channel 40:	2442 MHz	Channel 60:	2462 MHz
Channel 01:	2403 MHz	Channel 21:	2423 MHz	Channel 41:	2443 MHz	Channel 61:	2463 MHz
Channel 02:	2404 MHz	Channel 22:	2424 MHz	Channel 42:	2444 MHz	Channel 62:	2464 MHz
Channel 03:	2405 MHz	Channel 23:	2425 MHz	Channel 43:	2445 MHz	Channel 63:	2465 MHz
Channel 04:	2406 MHz	Channel 24:	2426 MHz	Channel 44:	2446 MHz	Channel 64:	2466 MHz
Channel 05:	2407 MHz	Channel 25:	2427 MHz	Channel 45:	2447 MHz	Channel 65:	2467 MHz
Channel 06:	2408 MHz	Channel 26:	2428 MHz	Channel 46:	2448 MHz	Channel 66:	2468 MHz
Channel 07:	2409 MHz	Channel 27:	2429 MHz	Channel 47:	2449 MHz	Channel 67:	2469 MHz
Channel 08:	2410 MHz	Channel 28:	2430 MHz	Channel 48:	2450 MHz	Channel 68:	2470 MHz
Channel 09:	2411 MHz	Channel 29:	2431 MHz	Channel 49:	2451 MHz	Channel 69:	2471 MHz
Channel 10:	2412 MHz	Channel 30:	2432 MHz	Channel 50:	2452 MHz	Channel 70:	2472 MHz
Channel 11:	2413 MHz	Channel 31:	2433 MHz	Channel 51:	2453 MHz	Channel 71:	2473 MHz
Channel 12:	2414 MHz	Channel 32:	2434 MHz	Channel 52:	2454 MHz	Channel 72:	2474 MHz
Channel 13:	2415 MHz	Channel 33:	2435 MHz	Channel 53:	2455 MHz	Channel 73:	2475 MHz
Channel 14:	2416 MHz	Channel 34:	2436 MHz	Channel 54:	2456 MHz	Channel 74:	2476 MHz
Channel 15:	2417 MHz	Channel 35:	2437 MHz	Channel 55:	2457 MHz	Channel 75:	2477 MHz
Channel 16:	2418 MHz	Channel 36:	2438 MHz	Channel 56:	2458 MHz	Channel 76:	2478 MHz
Channel 17:	2419 MHz	Channel 37:	2439 MHz	Channel 57:	2459 MHz	Channel 77:	2479 MHz
Channel 18:	2420 MHz	Channel 38:	2440 MHz	Channel 58:	2460 MHz	Channel 78:	2480 MHz
Channel 19:	2421 MHz	Channel 39:	2441 MHz	Channel 59:	2461 MHz		

Note:

1. The EUT is a Tablet PC with built-in WLAN and Bluetooth V4.0 、 V2.1+EDR transceiver, this report for Bluetooth V2.1+EDR.
2. These tests were conducted on a sample for the purpose of demonstrating compliance of Bluetooth V2.1+EDR transceiver with Part 15 Subpart C Paragraph 15.247 for spread spectrum devices.
3. Regarding to the operation frequency, the lowest, middle and highest frequency are selected to perform the test.
4. The radiation measurements are performed in X, Y, Z axis positioning. Only the worst case is shown in the report.
5. Bluetooth operation was evaluated at both 1Mb/s and 3Mb/s data rates. 2Mb/s data rate was found, through pre-testing, to produce emissions similar to those for 3Mb/s.

Test Mode	Mode 1: Transmit - 1Mbps Mode 2: Transmit - 3Mbps
-----------	--

1.3. Tested System Details

The types for all equipment, plus descriptions of all cables used in the tested system (including inserted cards) are:

Product	Manufacturer	Model No.	Serial No.	Power Cord
1 Monitor	DELL	U2415	CN-01RMGX-74261-6 3H-09UL-A02	Non-shielded, 1.8m
2 Earphone	Verbatim	N/A	N/A	N/A
3 USB 3.0	WD	WDBUZG0010 BBK-PESN	WX11A166S2Y3	N/A
4 Converter (MicorUSB to USB)	N/A	N/A	N/A	N/A
5 Micro SD Card	Sandisk	32GB	N/A	N/A

Signal Cable Type	Signal cable Description
A Micro HDMI to HDMI Cable	Shielded, 1.8m
B Earphone Cable	Non-shielded, 1m
C USB Cable	Shielded, 0.3m

1.4. Configuration of Tested System

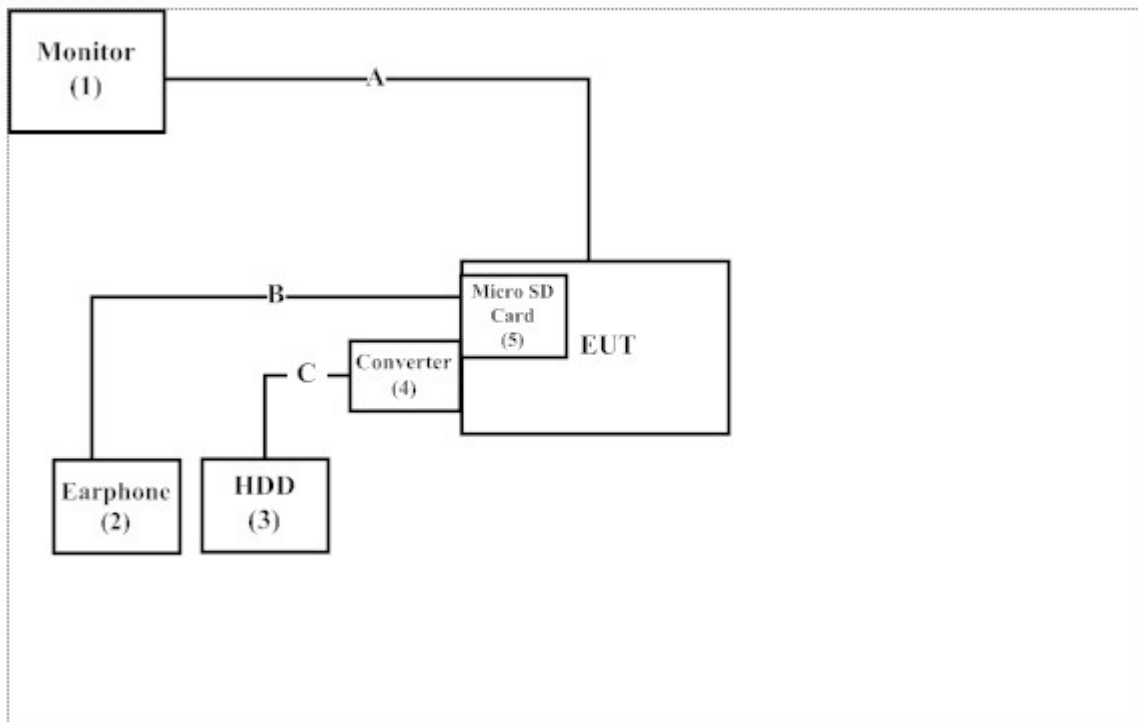

1.5. EUT Exercise Software

1. Setup the EUT as shown in Section 1.4.
2. Execute software “MT6571 va.6C.2” on the EUT.
3. Configure the test mode, the test channel, and the data rate.
4. Press “OK” to start the continuous Transmit.
5. Verify that the EUT works properly.

1.6. Test Facility

Ambient conditions in the laboratory:

Items	Required (IEC 68-1)	Actual
Temperature (°C)	15-35	20-35
Humidity (%RH)	25-75	50-65
Barometric pressure (mbar)	860-1060	950-1000

The related certificate for our laboratories about the test site and management system can be downloaded from DEKRA Testing and Certification Co., Ltd. Web Site:

<http://www.dekra.com.tw/english/about/certificates.aspx?bval=5>

The address and introduction of DEKRA Testing and Certification Co., Ltd. laboratories can be founded in our Web site: http://www.dekra.com.tw/index_en

Site Description: Accredited by TAF
Accredited Number: 3023

Site Name: DEKRA Testing and Certification Co., Ltd.
Site Address: No.159, Sec. 2, Wenhua 1st Rd., Linkou Dist.,
New Taipei City 24457, Taiwan.
TEL: 886-2-2602-7968 / FAX : 866-2-2602-3286
E-Mail : info.tw@dekra.com

FCC Accreditation Number: TW3023

1.7. List of Test Equipment

For Conduction measurements /ASR1

	Equipment	Manufacturer	Model No.	Serial No.	Cali. Data	Due. Data
X	EMI Test Receiver	R&S	ESR7	101602	2017.12.11	2018.12.10
X	Two-Line V-Network	R&S	ENV216	101306	2017.02.16	2018.02.15
X	Two-Line V-Network	R&S	ENV216	101307	2017.03.17	2018.03.16
X	Coaxial Cable	Quietek	RG400_BNC	RF001	2017.05.24	2018.05.23

Note:

1. All equipments are calibrated every one year.
2. The test instruments marked with "X" are used to measure the final test results.
3. Test Software version : QuieTek EMI 2.0 V2.1.113

For Conducted measurements /ASR4

	Equipment	Manufacturer	Model No.	Serial No.	Cali. Data	Due. Data
X	Spectrum Analyzer	R&S	FSV30	103466	2017.12.19	2018.12.18
X	Power Meter	Anritsu	ML2496A	1548003	2017.12.11	2018.12.10
X	Power Sensor	Anritsu	MA2411B	1531024	2017.12.11	2018.12.10
X	Power Sensor	Anritsu	MA2411B	1531025	2017.12.11	2018.12.10

Note:

1. All equipments are calibrated every one year.
2. The test instruments marked with "X" are used to measure the final test results.
3. Test Software version : QuieTek Conduction Test System V8.0.110

For Radiated measurements /ACB1

	Equipment	Manufacturer	Model No.	Serial No.	Cali. Data	Due. Data
X	Loop Antenna	TESEQ	HLA6121	37133	2016.03.18	2018.03.17
X	Bi-Log Antenna	SCHWARZBECK	VULB9168	9168-674	2017.02.13	2018.02.12
X	Horn Antenna	ETS-Lindgren	3117	00203800	2017.11.10	2018.11.09
X	Horn Antenna	Com-Power	AH-840	101087	2017.05.24	2018.05.23
X	Pre-Amplifier	EMCI	EMC001330	980316	2017.05.16	2018.05.15
X	Pre-Amplifier	EMCI	EMC051835SE	980311	2017.05.17	2018.05.16
X	Pre-Amplifier	EMCI	EMC05820SE	980310	2017.05.17	2018.05.16
X	Pre-Amplifier	EMCI	EMC184045SE	980314	2017.05.17	2018.05.16
X	Filter	MICRO TRONICS	BRM50702	G251	2017.08.30	2018.08.29
	Filter	MICRO TRONICS	BRM50716	G188	2017.08.30	2018.08.29
X	EMI Test Receiver	R&S	ESR7	101602	2017.12.11	2018.12.10
X	Spectrum Analyzer	R&S	FSV40	101147	2018.01.11	2019.01.10
X	Coaxial Cable	SUHNER	SUCOFLEX 106	RF002	2017.05.25	2018.05.24
X	Mircoflex Cable	HUBER SUHNER	SUCOFLEX 102	MY3381/2	2017.08.11	2018.08.10

Note:

1. Loop Antenna is calibrated every two year, the other equipments are calibrated every one year.
2. The test instruments marked with "X" are used to measure the final test results.
3. Test Software version : QuieTek EMI 2.0 V2.1.113

2. Conducted Emission

2.1. Test Setup

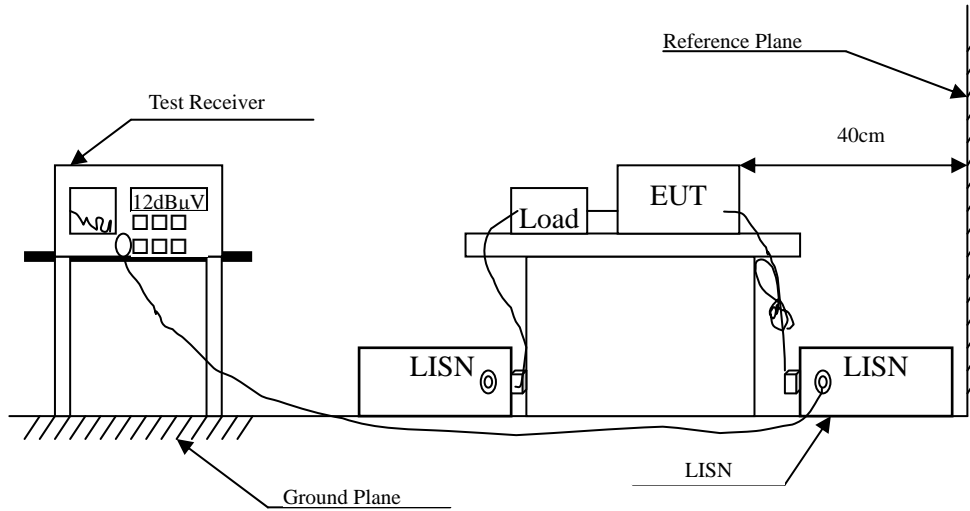

2.2. Limits

FCC Part 15 Subpart C Paragraph 15.207 (dB μ V) Limit		
Frequency MHz	Limits	
	QP	AV
0.15 - 0.50	66-56	56-46
0.50-5.0	56	46
5.0 - 30	60	50

Remarks: In the above table, the tighter limit applies at the band edges.

2.3. Test Procedure

The EUT and Peripherals are connected to the main power through a line impedance stabilization network (L.I.S.N.). This provides a 50 ohm /50uH coupling impedance for the measuring equipment. The peripheral devices are also connected to the main power through a LISN that provides a 50ohm /50uH coupling impedance with 50ohm termination. (Please refer to the block diagram of the test setup and photographs.)

Both sides of A.C. line are checked for maximum conducted interference. In order to find the maximum emission, the relative positions of equipment and all the interface cables must be changed according to ANSI C63.4: 2014 on conducted measurement.

Conducted emissions were investigated over the frequency range from 0.15MHz to 30MHz using a receiver bandwidth of 9kHz.

The EUT was setup to ANSI C63.4, 2014; tested to FHSS test procedure of FCC Public Notice DA 00-705 for compliance to FCC 47CFR 15.247 requirements.

2.4. Uncertainty

±2.35dB

2.5. Test Result of Conducted Emission

Product : Tablet PC
 Test Item : Conducted Emission Test
 Power Line : Line 1
 Test Mode : Mode 2: Transmit - 3Mbps (2441MHz)
 Test Date : 2018/01/18

Frequency MHz	Correct Factor dB	Reading Level dB μ V	Measurement Level dB μ V	Margin dB	Limit dB μ V
LINE 1					
Quasi-Peak					
0.152	9.616	38.632	48.248	-17.695	65.943
0.413	9.694	24.871	34.565	-23.921	58.486
2.344	9.759	36.346	46.104	-9.896	56.000
2.798	9.776	35.439	45.215	-10.785	56.000
11.137	9.956	30.729	40.685	-19.315	60.000
24.576	10.100	28.608	38.708	-21.292	60.000
Average					
0.152	9.616	16.302	25.918	-30.025	55.943
0.413	9.694	14.360	24.053	-24.433	48.486
2.344	9.759	23.596	33.355	-12.645	46.000
2.798	9.776	25.199	34.975	-11.025	46.000
11.137	9.956	21.529	31.485	-18.515	50.000
24.576	10.100	25.550	35.650	-14.350	50.000

Note:

1. All Reading Levels are Quasi-Peak and average value.
2. "■" means the worst emission level.
3. Measurement Level = Reading Level + Correct Factor

Product : Tablet PC
 Test Item : Conducted Emission Test
 Power Line : Line 2
 Test Mode : Mode 2: Transmit - 3Mbps (2441MHz)
 Test Date : 2018/01/18

Frequency MHz	Correct Factor dB	Reading Level dB μ V	Measurement Level dB μ V	Margin dB	Limit dB μ V
LINE 2					
Quasi-Peak					
0.152	9.607	37.938	47.545	-18.398	65.943
0.177	9.669	33.228	42.897	-22.332	65.229
0.422	9.688	27.168	36.856	-21.373	58.229
2.643	9.766	34.290	44.056	-11.944	56.000
11.060	9.961	29.584	39.545	-20.455	60.000
24.576	10.140	27.053	37.193	-22.807	60.000
Average					
0.152	9.607	18.770	28.377	-27.566	55.943
0.177	9.669	18.008	27.677	-27.552	55.229
0.422	9.688	16.992	26.679	-21.550	48.229
2.643	9.766	25.540	35.306	-10.694	46.000
11.060	9.961	19.917	29.878	-20.122	50.000
24.576	10.140	23.893	34.033	-15.967	50.000

Note:

1. All Reading Levels are Quasi-Peak and average value.
2. "■" means the worst emission level.
3. Measurement Level = Reading Level + Correct Factor

3. Peak Power Output

3.1. Test Setup

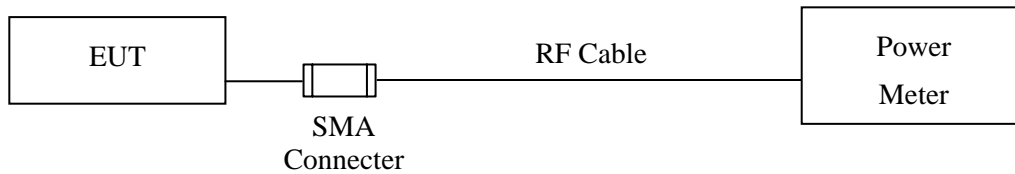

3.2. Limit

The maximum peak power shall be less 1Watt.

3.3. Test Procedure

The EUT was setup to ANSI C63.4, 2014; tested to FHSS test procedure of FCC Public Notice DA 00-705 for compliance to FCC 47CFR 15.247 requirements.

3.4. Uncertainty

± 0.86 dB

3.5. Test Result of Peak Power Output

Product : Tablet PC
Test Item : Peak Power Output
Test Mode : Mode 1: Transmit - 1Mbps
Test Date : 2018/01/17

Channel No.	Frequency (MHz)	Measurement (dBm)	Required Limit	Result
Channel 00	2402.00	4.93	1 Watt= 30 dBm	Pass
Channel 39	2441.00	6.19	1 Watt= 30 dBm	Pass
Channel 78	2480.00	5.83	1 Watt= 30 dBm	Pass

Product : Tablet PC
Test Item : Peak Power Output
Test Mode : Mode 2: Transmit - 3Mbps
Test Date : 2018/01/17

Channel No.	Frequency (MHz)	Measurement (dBm)	Required Limit	Result
Channel 00	2402.00	4.39	1 Watt= 30 dBm	Pass
Channel 39	2441.00	5.72	1 Watt= 30 dBm	Pass
Channel 78	2480.00	5.31	1 Watt= 30 dBm	Pass

4. Radiated Emission

4.1. Test Setup

Radiated Emission Under 30MHz

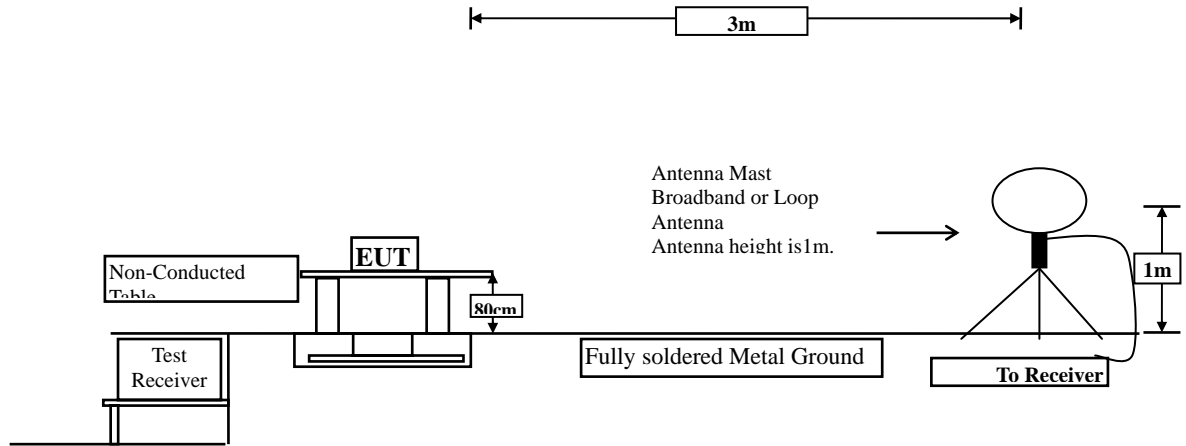

Radiated Emission Below 1GHz

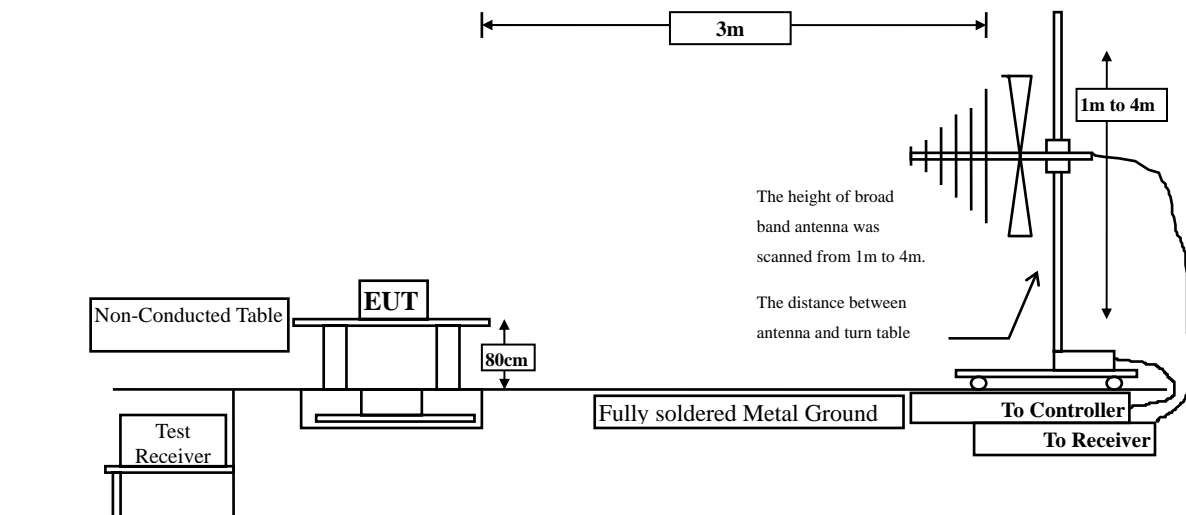

Radiated Emission Above 1GHz

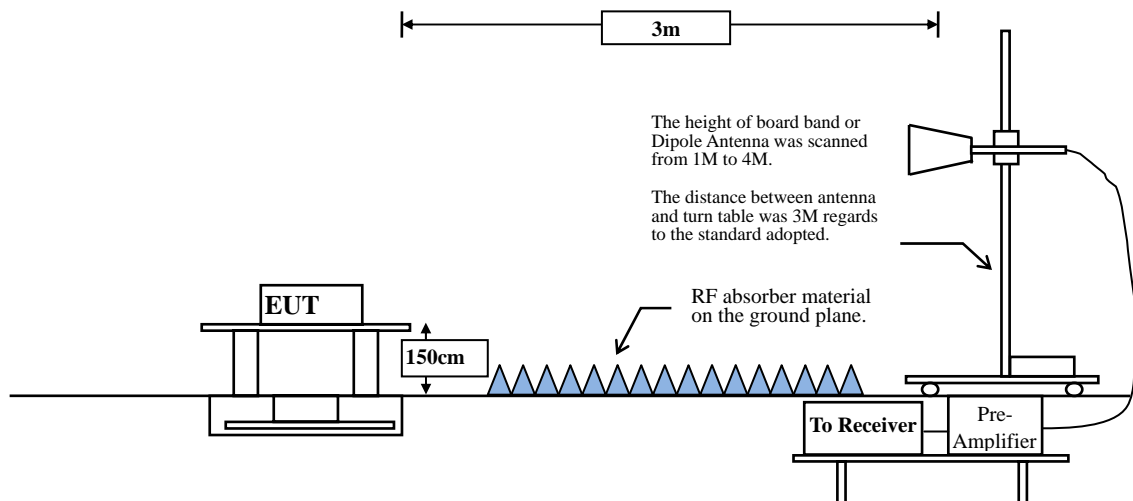

4.2. Limits

➤ General Radiated Emission Limits

Emissions radiated outside of the specified frequency bands, except for harmonics, shall be attenuated by at least 20dB below the level of the fundamental or to the general radiated emission limits in paragraph 15.209, whichever is the lesser attenuation.

FCC Part 15 Subpart C Paragraph 15.209 Limits		
Frequency MHz	Field strength (microvolts/meter)	Measurement distance (meter)
0.009-0.490	2400/F(kHz)	300
0.490-1.705	24000/F(kHz)	30
1.705-30	30	30
30-88	100	3
88-216	150	3
216-960	200	3
Above 960	500	3

- Remarks:
1. RF Voltage (dBuV) = 20 log RF Voltage (uV)
 2. In the Above Table, the tighter limit applies at the band edges.
 3. Distance refers to the distance in meters between the measuring instrument antenna and the closed point of any part of the device or system.

4.3. Test Procedure

The EUT was setup according to ANSI C63.10, 2013 and tested compliance to FCC 47CFR 15.247 requirements.

Measuring the frequency range below 1GHz, the EUT is placed on a turn table which is 0.8 meter above ground, when measuring the frequency range above 1GHz, the EUT is placed on a turn table which is 1.5 meter above ground.

The turn table is rotated 360 degrees to determine the position of the maximum emission level.

The EUT was positioned such that the distance from antenna to the EUT was 3 meters.

The antenna is scanned between 1 meter and 4 meters to find out the maximum emission level. This is repeated for both horizontal and vertical polarization of the antenna. In order to find the maximum emission, all of the interface cables were manipulated according to ANSI C63.10: 2013 on radiated measurement.

The resolution bandwidth below 30MHz setting on the field strength meter is 9kHz and 30MHz~1GHz is 120kHz and above 1GHz is 1MHz.

Radiated emission measurements below 30MHz are made using Loop Antenna and 30MHz~1GHz are made using broadband Bilog antenna and above 1GHz are made using Horn Antennas.

The measurement is divided into the Preliminary Measurement and the Final Measurement.

The suspected frequencies are searched for in Preliminary Measurement with the measurement antenna kept pointed at the source of the emission both in azimuth and elevation, with the polarization of the antenna oriented for maximum response. The antenna is pointed at an angle towards the source of the emission, and the EUT is rotated in both height and polarization to maximize the measured emission. The emission is kept within the illumination area of the 3 dB bandwidth of the antenna.

The measurement frequency range from 9kHz - 10th Harmonic of fundamental was investigated.

4.4. Uncertainty

Horizontal polarization :

30-300MHz: ± 4.08 dB ; 300M-1GHz: ± 3.86 dB ; 1-18GHz: ± 3.77 dB ; 18-40GHz: ± 3.98 dB

Vertical polarization :

30-300MHz: ± 4.81 dB ; 300M-1GHz: ± 3.87 dB ; 1-18GHz : ± 3.83 dB ; 18-40GHz: ± 3.98 dB

4.5. Test Result of Radiated Emission

Product : Tablet PC
 Test Item : Harmonic Radiated Emission
 Test Mode : Mode 1: Transmit - 1Mbps(2402MHz)
 Test Date : 2018/01/16

Frequency MHz	Correct Factor dB	Reading Level dB μ V	Measurement Level dB μ V/m	Margin dB	Limit dB μ V/m
Horizontal					
Peak Detector:					
4804.000	-2.875	51.090	48.216	-25.784	74.000
7206.000	0.384	44.450	44.834	-29.166	74.000
9608.000	2.338	43.370	45.708	-28.292	74.000
Average Detector:					
--					54.000
Vertical					
Peak Detector:					
4804.000	-2.875	48.910	46.036	-27.964	74.000
7206.000	0.384	44.840	45.224	-28.776	74.000
9608.000	2.338	43.510	45.848	-28.152	74.000
Average Detector:					
--					54.000

Note:

1. All Readings below 1GHz are Quasi-Peak, above 1GHz are performed with peak and/or average measurements as necessary.
2. Peak measurements: RBW = 1MHz, VBW = 3 MHz, Sweep: Auto.
3. Average measurements: RBW = 1MHz, VBW = 10 Hz, Sweep: Auto.
4. Measurement Level = Reading Level + Correct Factor.
5. Correct Factor = Antenna factor + Cable loss – Amplifier gain.
6. The average measurement was not performed when the peak measured data under the limit of average detection.
7. The emission levels of other frequencies are very lower than the limit and not show in test report.

Product : Tablet PC
 Test Item : Harmonic Radiated Emission
 Test Mode : Mode 1: Transmit - 1Mbps(2441MHz)
 Test Date : 2018/01/16

Frequency MHz	Correct Factor dB	Reading Level dB μ V	Measurement Level dB μ V/m	Margin dB	Limit dB μ V/m
Horizontal					
Peak Detector:					
4882.000	-2.812	49.590	46.778	-27.222	74.000
7323.000	0.464	45.130	45.594	-28.406	74.000
9764.000	2.615	44.160	46.774	-27.226	74.000
Average Detector:					
--					54.000
Vertical					
Peak Detector:					
4882.000	-2.812	47.660	44.848	-29.152	74.000
7323.000	0.464	45.170	45.634	-28.366	74.000
9764.000	2.615	44.090	46.704	-27.296	74.000
Average Detector:					
--					54.000

Note:

1. All Readings below 1GHz are Quasi-Peak, above 1GHz are performed with peak and/or average measurements as necessary.
2. Peak measurements: RBW = 1MHz, VBW = 3 MHz, Sweep: Auto.
3. Average measurements: RBW = 1MHz, VBW = 10 Hz, Sweep: Auto.
4. Measurement Level = Reading Level + Correct Factor.
5. Correct Factor = Antenna factor + Cable loss – Amplifier gain.
6. The average measurement was not performed when the peak measured data under the limit of average detection.
7. The emission levels of other frequencies are very lower than the limit and not show in test report.

Product : Tablet PC
 Test Item : Harmonic Radiated Emission
 Test Mode : Mode 1: Transmit - 1Mbps(2480MHz)
 Test Date : 2018/01/16

Frequency MHz	Correct Factor dB	Reading Level dB μ V	Measurement Level dB μ V/m	Margin dB	Limit dB μ V/m
Horizontal					
Peak Detector:					
4960.000	-2.791	48.970	46.179	-27.821	74.000
7440.000	0.499	44.110	44.609	-29.391	74.000
9920.000	2.917	43.810	46.727	-27.273	74.000
Average Detector:					
--					54.000
Vertical					
Peak Detector:					
4960.000	-2.791	48.210	45.419	-28.581	74.000
7440.000	0.499	44.380	44.879	-29.121	74.000
9920.000	2.917	43.550	46.467	-27.533	74.000
Average Detector:					
--					54.000

Note:

1. All Readings below 1GHz are Quasi-Peak, above 1GHz are performed with peak and/or average measurements as necessary.
2. Peak measurements: RBW = 1MHz, VBW = 3 MHz, Sweep: Auto.
3. Average measurements: RBW = 1MHz, VBW = 10 Hz, Sweep: Auto.
4. Measurement Level = Reading Level + Correct Factor.
5. Correct Factor = Antenna factor + Cable loss – Amplifier gain.
6. The average measurement was not performed when the peak measured data under the limit of average detection.
7. The emission levels of other frequencies are very lower than the limit and not show in test report.

Product : Tablet PC
 Test Item : Harmonic Radiated Emission
 Test Mode : Mode 2: Transmit - 3Mbps(2402MHz)
 Test Date : 2018/01/16

Frequency MHz	Correct Factor dB	Reading Level dBμV	Measurement Level dBμV/m	Margin dB	Limit dBμV/m
Horizontal					
Peak Detector:					
4804.000	-2.875	48.520	45.646	-28.354	74.000
7206.000	0.384	44.830	45.214	-28.786	74.000
9608.000	2.338	43.770	46.108	-27.892	74.000
Average Detector:					
--					54.000
Vertical					
Peak Detector:					
4804.000	-2.875	47.320	44.446	-29.554	74.000
7206.000	0.384	44.980	45.364	-28.636	74.000
9608.000	2.338	43.860	46.198	-27.802	74.000
Average Detector:					
--					54.000

Note:

1. All Readings below 1GHz are Quasi-Peak, above 1GHz are performed with peak and/or average measurements as necessary.
2. Peak measurements: RBW = 1MHz, VBW = 3 MHz, Sweep: Auto.
3. Average measurements: RBW = 1MHz, VBW = 10 Hz, Sweep: Auto.
4. Measurement Level = Reading Level + Correct Factor.
5. Correct Factor = Antenna factor + Cable loss – Amplifier gain.
6. The average measurement was not performed when the peak measured data under the limit of average detection.
7. The emission levels of other frequencies are very lower than the limit and not show in test report.

Product : Tablet PC
 Test Item : Harmonic Radiated Emission
 Test Mode : Mode 2: Transmit - 3Mbps (2441MHz)
 Test Date : 2018/01/16

Frequency MHz	Correct Factor dB	Reading Level dBµV	Measurement Level dBµV/m	Margin dB	Limit dBµV/m
Horizontal					
Peak Detector:					
4882.000	-2.812	47.210	44.398	-29.602	74.000
7323.000	0.464	44.710	45.174	-28.826	74.000
9764.000	2.615	44.750	47.364	-26.636	74.000
Average Detector:					
--					54.000
Vertical					
Peak Detector:					
4882.000	-2.812	47.110	44.298	-29.702	74.000
7323.000	0.464	44.930	45.394	-28.606	74.000
9764.000	2.615	44.650	47.264	-26.736	74.000
Average Detector:					
--					54.000

Note:

1. All Readings below 1GHz are Quasi-Peak, above 1GHz are performed with peak and/or average measurements as necessary.
2. Peak measurements: RBW = 1MHz, VBW = 3 MHz, Sweep: Auto.
3. Average measurements: RBW = 1MHz, VBW = 10 Hz, Sweep: Auto.
4. Measurement Level = Reading Level + Correct Factor.
5. Correct Factor = Antenna factor + Cable loss – Amplifier gain.
6. The average measurement was not performed when the peak measured data under the limit of average detection.
7. The emission levels of other frequencies are very lower than the limit and not show in test report.

Product : Tablet PC
 Test Item : Harmonic Radiated Emission
 Test Mode : Mode 2: Transmit - 3Mbps (2480MHz)
 Test Date : 2018/01/16

Frequency MHz	Correct Factor dB	Reading Level dB μ V	Measurement Level dB μ V/m	Margin dB	Limit dB μ V/m
Horizontal					
Peak Detector:					
4960.000	-2.791	47.730	44.939	-29.061	74.000
7440.000	0.499	44.350	44.849	-29.151	74.000
9920.000	2.917	43.760	46.677	-27.323	74.000
Average Detector:					
--					54.000
Vertical					
Peak Detector:					
4960.000	-2.791	46.430	43.639	-30.361	74.000
7440.000	0.499	43.960	44.459	-29.541	74.000
9920.000	2.917	43.680	46.597	-27.403	74.000
Average Detector:					
--					54.000

Note:

1. All Readings below 1GHz are Quasi-Peak, above 1GHz are performed with peak and/or average measurements as necessary.
2. Peak measurements: RBW = 1MHz, VBW = 3 MHz, Sweep: Auto.
3. Average measurements: RBW = 1MHz, VBW = 10 Hz, Sweep: Auto.
4. Measurement Level = Reading Level + Correct Factor.
5. Correct Factor = Antenna factor + Cable loss – Amplifier gain.
6. The average measurement was not performed when the peak measured data under the limit of average detection.
7. The emission levels of other frequencies are very lower than the limit and not show in test report.

Product : Tablet PC
 Test Item : General Radiated Emission
 Test Mode : Mode 1: Transmit - 1Mbps (2441MHz)
 Test Date : 2018/01/18

Frequency MHz	Correct Factor dB	Reading Level dB μ V	Measurement Level dB μ V/m	Margin dB	Limit dB μ V/m
Horizontal					
353.333	-8.662	35.176	26.514	-19.486	46.000
406.754	-7.186	33.657	26.471	-19.529	46.000
700.565	-1.650	30.226	28.576	-17.424	46.000
775.072	-0.610	30.617	30.007	-15.993	46.000
865.043	0.511	30.567	31.077	-14.923	46.000
966.261	1.690	30.279	31.969	-22.031	54.000
Vertical					
48.275	-10.834	42.962	32.128	-7.872	40.000
198.696	-13.469	35.547	22.077	-21.423	43.500
402.536	-7.284	32.675	25.392	-20.608	46.000
710.406	-1.488	29.990	28.502	-17.498	46.000
887.536	0.781	29.265	30.046	-15.954	46.000
963.449	1.648	29.727	31.376	-22.624	54.000

Note:

1. All Readings below 1GHz are Quasi-Peak, above 1GHz are performed with peak and/or average measurements as necessary.
2. Peak measurements: RBW = 1MHz, VBW = 3 MHz, Sweep: Auto.
3. Average measurements: RBW = 1MHz, VBW = 10 Hz, Sweep: Auto.
4. Measurement Level = Reading Level + Correct Factor.
5. Correct Factor = Antenna factor + Cable loss – Amplifier gain.
6. The average measurement was not performed when the peak measured data under the limit of average detection.
7. The emission levels of other frequencies are very lower than the limit and not show in test report.
8. No emission found between lowest internal used/generated frequency to 30MHz.

Product : Tablet PC
 Test Item : General Radiated Emission
 Test Mode : Mode 2: Transmit - 3Mbps (2441MHz)
 Test Date : 2018/01/18

Frequency MHz	Correct Factor dB	Reading Level dB μ V	Measurement Level dB μ V/m	Margin dB	Limit dB μ V/m
Horizontal					
143.870	-10.829	35.160	24.331	-19.169	43.500
356.145	-8.584	37.333	28.749	-17.251	46.000
638.710	-2.735	30.687	27.952	-18.048	46.000
735.710	-1.094	29.994	28.900	-17.100	46.000
887.536	0.781	30.554	31.335	-14.665	46.000
998.594	2.199	29.533	31.732	-22.268	54.000
Vertical					
46.870	-10.839	42.667	31.828	-8.172	40.000
200.101	-13.473	37.153	23.679	-19.821	43.500
406.754	-7.186	33.958	26.772	-19.228	46.000
709.000	-1.511	30.685	29.174	-16.826	46.000
886.130	0.764	32.023	32.787	-13.213	46.000
977.507	1.867	29.826	31.693	-22.307	54.000

Note:

1. All Readings below 1GHz are Quasi-Peak, above 1GHz are performed with peak and/or average measurements as necessary.
2. Peak measurements: RBW = 1MHz, VBW = 3 MHz, Sweep: Auto.
3. Average measurements: RBW = 1MHz, VBW = 10 Hz, Sweep: Auto.
4. Measurement Level = Reading Level + Correct Factor.
5. Correct Factor = Antenna factor + Cable loss – Amplifier gain.
6. The average measurement was not performed when the peak measured data under the limit of average detection.
7. The emission levels of other frequencies are very lower than the limit and not show in test report.
8. No emission found between lowest internal used/generated frequency to 30MHz.

5. RF Antenna Conducted Test

5.1. Test Setup

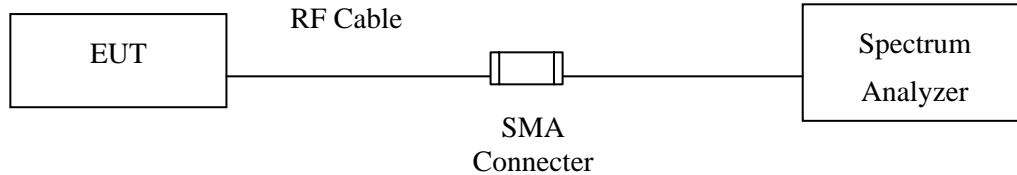

5.2. Limits

According to FCC Section 15.247(d). In any 100 kHz bandwidth outside the frequency band in which the spread spectrum or digitally modulated intentional radiator is operating, the radio frequency power that is produced by the intentional radiator shall be at least 20 dB below that in the 100 kHz bandwidth within the band that contains the highest level of the desired power, based on either an RF conducted or measurement, provided the transmitter demonstrates compliance with the peak conducted power limits. If the transmitter complies with the conducted power limits based on the use of RMS averaging over a time interval, the attenuation required under this paragraph shall be 30 dB instead of 20 dB.

5.3. Test Procedure

The EUT was setup to ANSI C63.4, 2014; tested to FHSS test procedure of FCC Public Notice DA 00-705 for compliance to FCC 47CFR 15.247 requirements.

5.4. Uncertainty

$\pm 1.23\text{dB}$

5.5. Test Result of RF Antenna Conducted Test

Product : Tablet PC
 Test Item : RF Antenna Conducted Test
 Test Mode : Mode 1: Transmit - 1Mbps
 Test Date : 2018/01/03

Figure Channel 00:

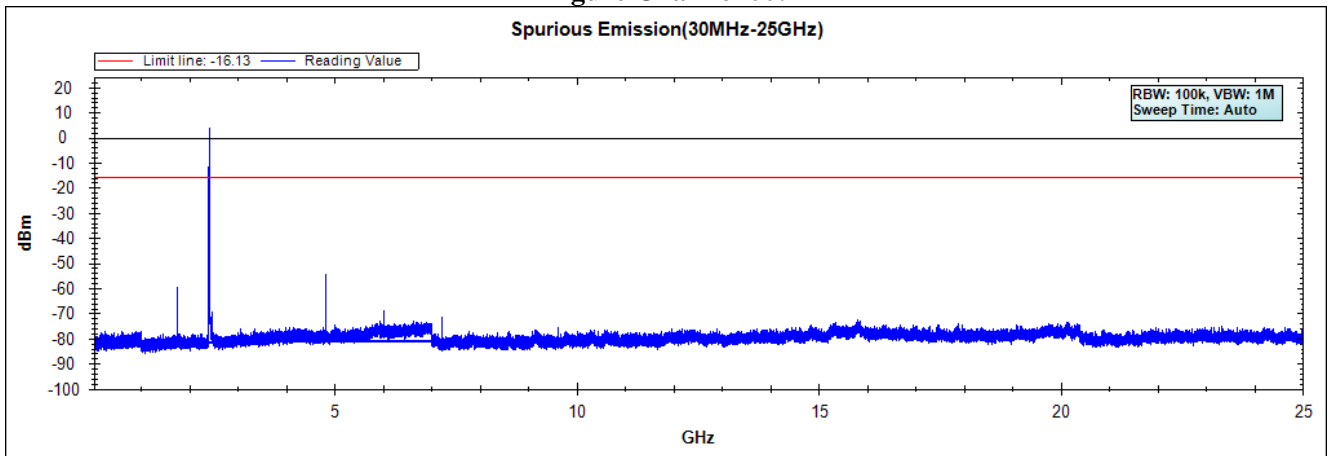

Figure Channel 39:

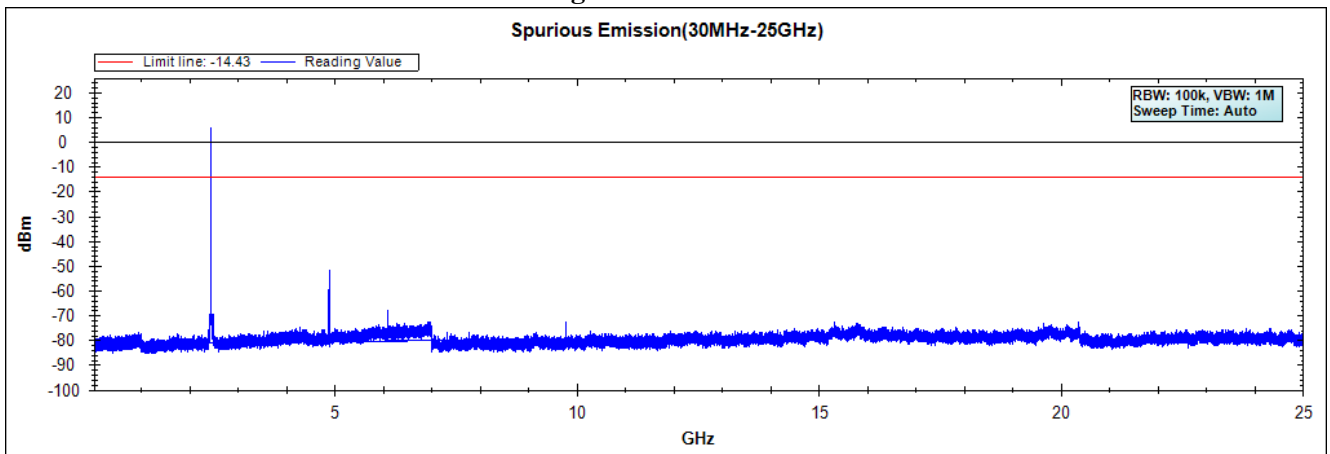
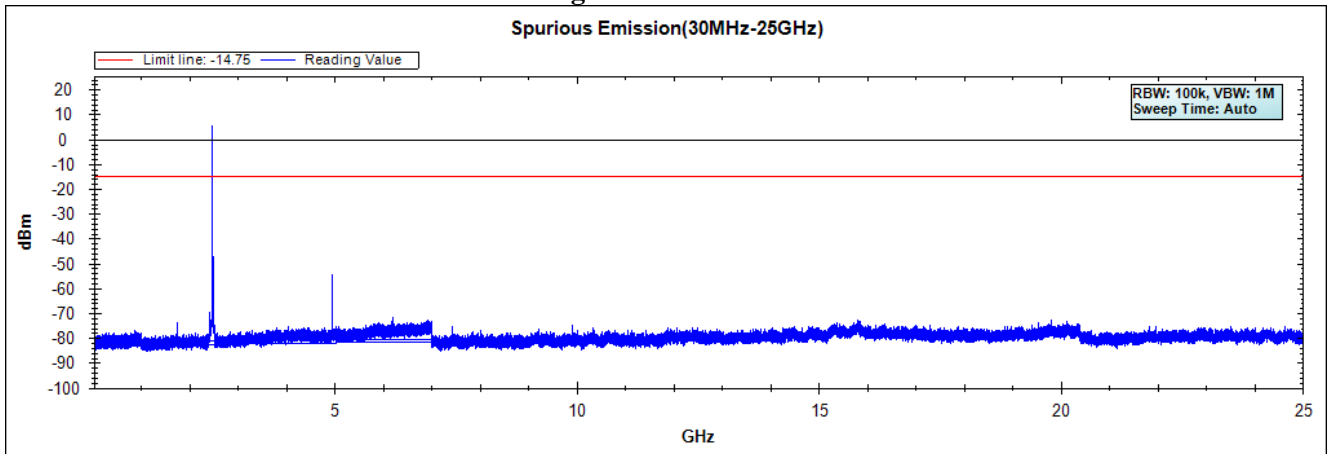

Figure Channel 78:



Note: The above test pattern is synthesized by multiple of the frequency range.

Product : Tablet PC
Test Item : RF Antenna Conducted Test
Test Mode : Mode 2: Transmit - 3Mbps
Test Date : 2018/01/08

Figure Channel 00:

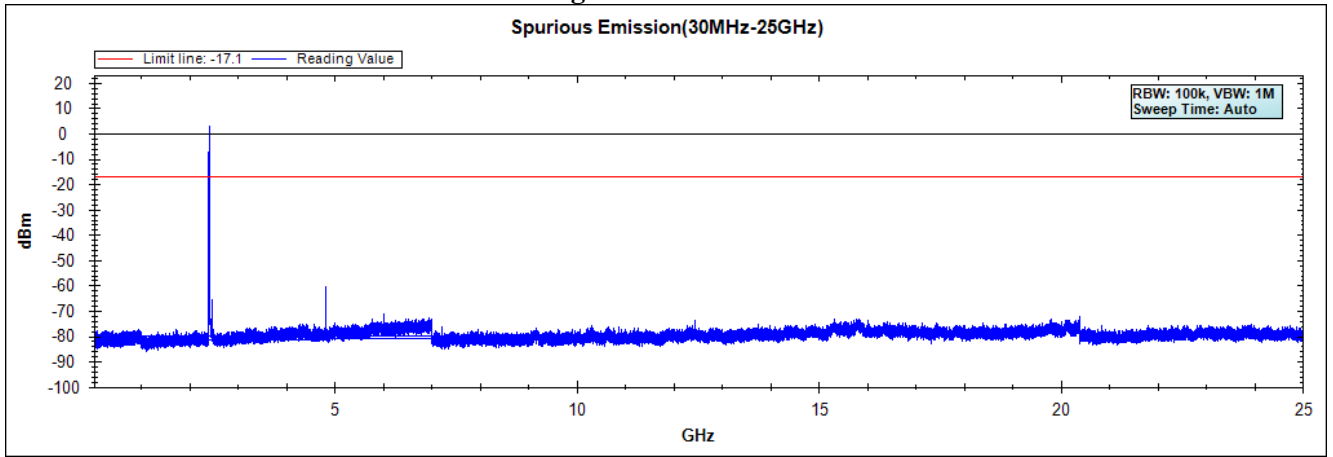

Figure Channel 39:

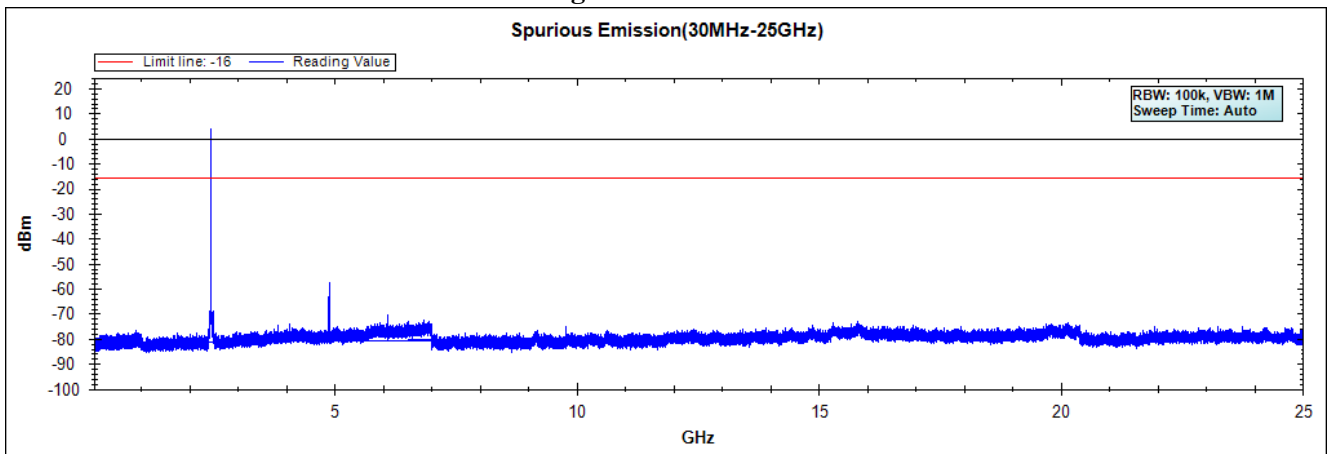
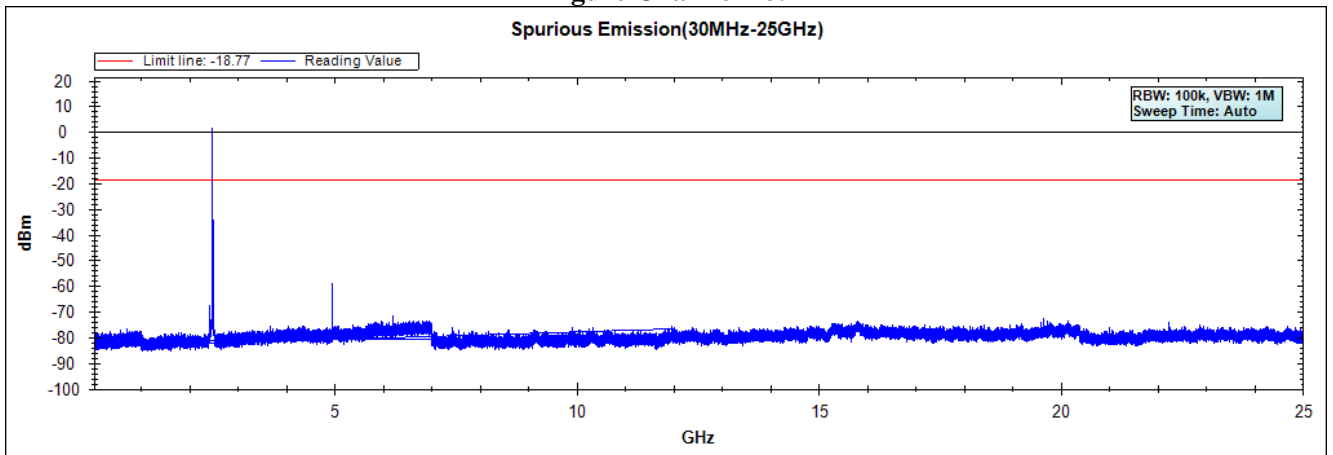

Figure Channel 78:



Note: The above test pattern is synthesized by multiple of the frequency range.

6. Band Edge

6.1. Test Setup

RF Conducted Measurement

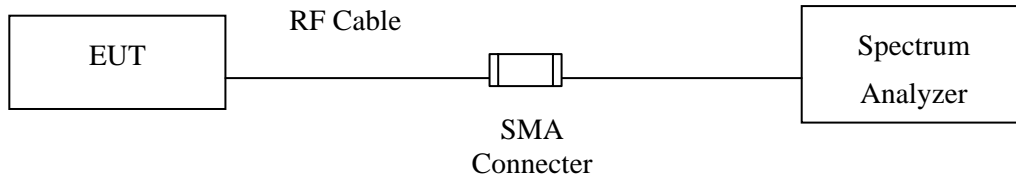

RF Radiated Measurement:

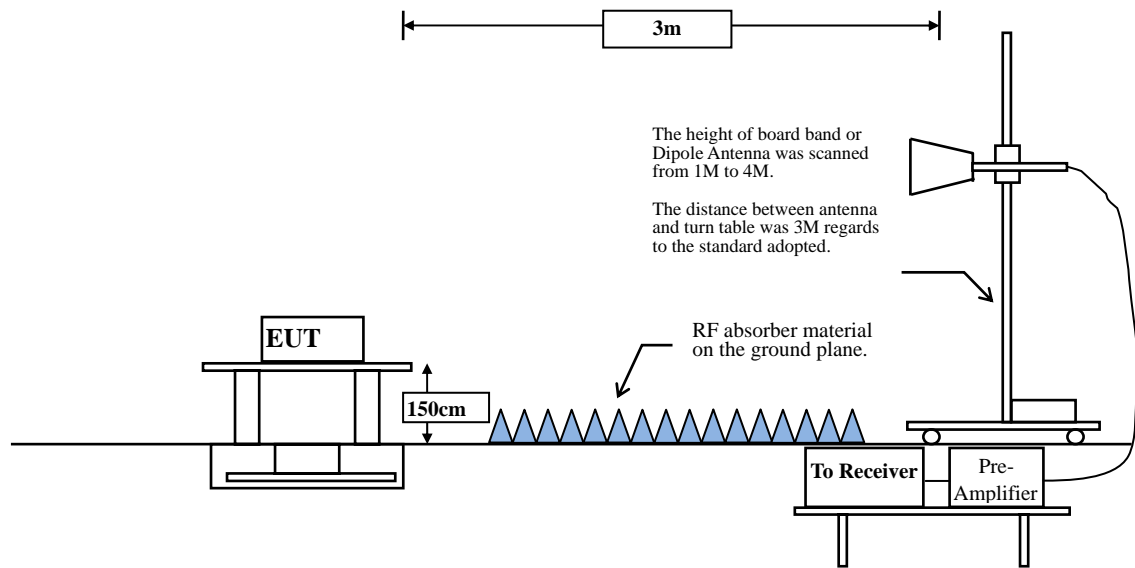

6.2. Limit

According to FCC Section 15.247(d). In any 100 kHz bandwidth outside the frequency band in which the spread spectrum or digitally modulated intentional radiator is operating, the radio frequency power that is produced by the intentional radiator shall be at least 20 dB below that in the 100 kHz bandwidth within the band that contains the highest level of the desired power, based on either an RF conducted or measurement, provided the transmitter demonstrates compliance with the peak conducted power limits. If the transmitter complies with the conducted power limits based on the use of RMS averaging over a time interval, the attenuation required under this paragraph shall be 30 dB instead of 20 dB. Attenuation below the general limits specified in Section 15.209(a) is not required. In addition, radiated emissions which fall in the restricted bands, as defined in Section 15.205(a), must also comply with the radiated emission limits specified in Section 15.209(a) (see Section 15.205(c)).

6.3. Test Procedure

The EUT is placed on a turn table which is 1.5 meter above ground. The turn table is rotated 360 degrees to determine the position of the maximum emission level. The EUT was positioned such that the distance from antenna to the EUT was 3 meters.

The antenna can move up and down between 1 meter and 4 meters to find out the maximum emission level.

Both horizontal and vertical polarization of the antenna are set on measurement. In order to find the maximum emission, all of the interface cables must be manipulated according to ANSI C63.10: 2013 on radiated measurement.

The bandwidth setting below 1GHz and above 1GHz on the field strength meter is 120 kHz and 1MHz, respectively.

6.4. Uncertainty

Conducted: ± 1.23 dB

Radiated:

Horizontal polarization : 1-18GHz: ± 3.77 dB

Vertical polarization : 1-18GHz : ± 3.83 dB

6.5. Test Result of Band Edge

Product : Tablet PC
 Test Item : Band Edge
 Test Mode : Mode 1: Transmit - 1Mbps (2402MHz)
 Test Date : 2018/01/16

RF Radiated Measurement (Horizontal):

Channel No.	Frequency (MHz)	Correct Factor (dB)	Reading Level (dBμV)	Emission Level (dBμV/m)	Peak Limit (dBμV/m)	Average Limit (dBμV/m)	Result
00 (Peak)	2387.101	12.139	30.748	42.888	74.00	54.00	Pass
00 (Peak)	2390.000	12.148	29.996	42.144	74.00	54.00	Pass
00 (Peak)	2400.000	12.176	53.997	66.173	--	--	Pass
00 (Peak)	2402.174	12.182	88.791	100.973	--	--	--
00 (Average)	2390.000	12.148	16.398	28.546	74.00	54.00	Pass
00 (Average)	2400.000	12.176	38.087	50.263	--	--	Pass
00 (Average)	2402.029	12.182	72.807	84.988	--	--	--

Figure Channel 00: Horizontal (Peak)

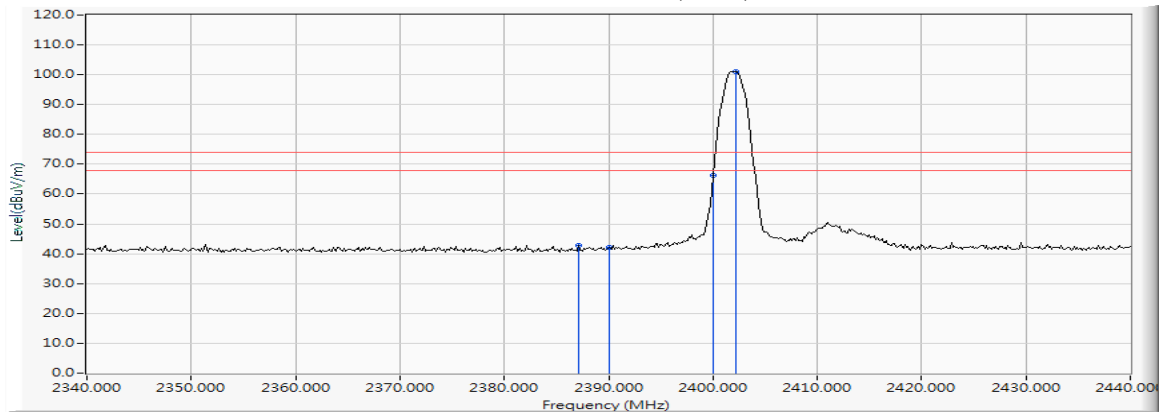
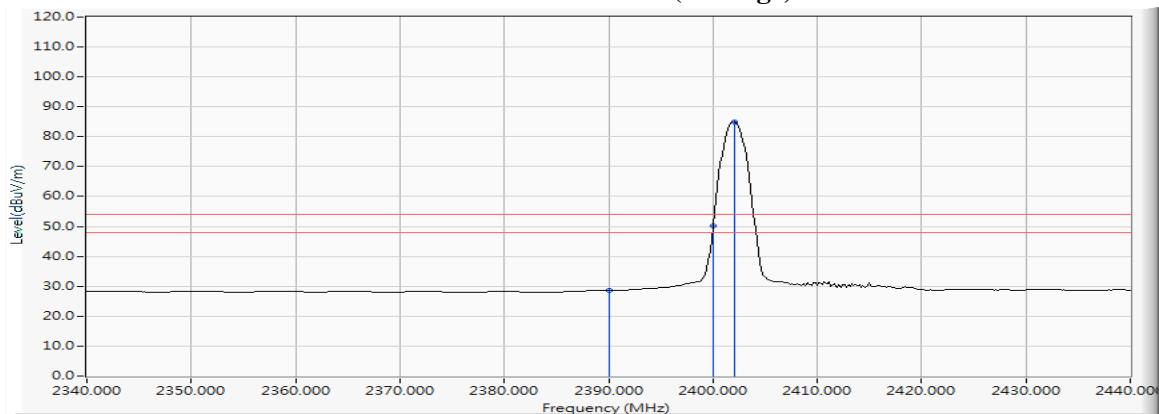

Figure Channel 00: Horizontal (Average)



Note:

1. All readings above 1GHz are performed with peak and/or average measurements as necessary.
2. Peak measurements: RBW = 1MHz, VBW = 3 MHz, Sweep: Auto.
3. Average measurements: RBW = 1MHz, VBW = 10 Hz, Sweep: Auto.
4. “ * ”, means this data is the worst emission level.
5. Measurement Level = Reading Level + Correction Factor.
6. The average measurement was not performed when the peak measured data is under the limit of average detection.

Product : Tablet PC
 Test Item : Band Edge
 Test Mode : Mode 1: Transmit - 1Mbps (2402MHz)
 Test Date : 2018/01/16

RF Radiated Measurement (VERTICAL):

Channel No.	Frequency (MHz)	Correct Factor (dB)	Reading Level (dBμV)	Emission Level (dBμV/m)	Peak Limit (dBμV/m)	Average Limit (dBμV/m)	Result
00 (Peak)	2389.855	12.147	30.663	42.811	74.00	54.00	Pass
00 (Peak)	2390.000	12.148	29.339	41.487	74.00	54.00	Pass
00 (Peak)	2400.000	12.176	54.902	67.078	--	--	Pass
00 (Peak)	2402.174	12.182	89.621	101.803	--	--	--
00 (Average)	2390.000	12.148	16.383	28.531	74.00	54.00	Pass
00 (Average)	2400.000	12.176	38.644	50.820	--	--	Pass
00 (Average)	2402.029	12.182	73.425	85.606	--	--	--

Figure Channel 00: VERTICAL (Peak)

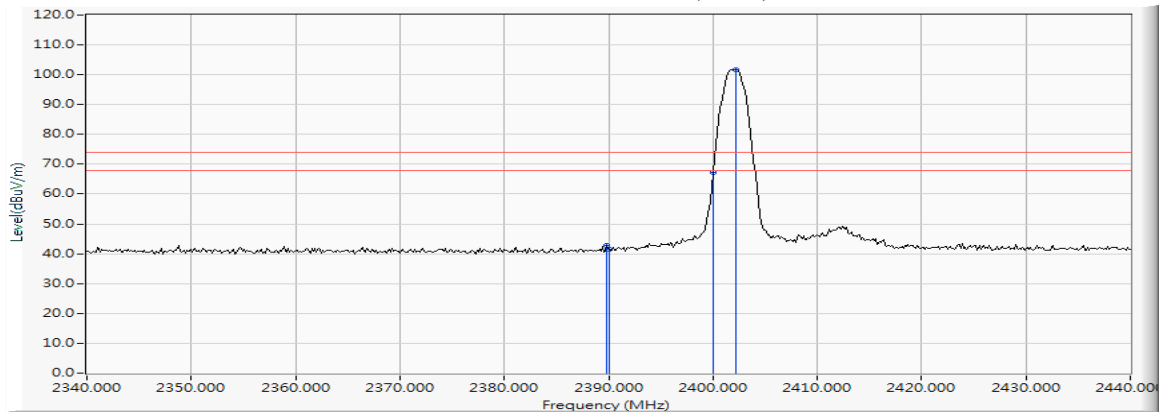
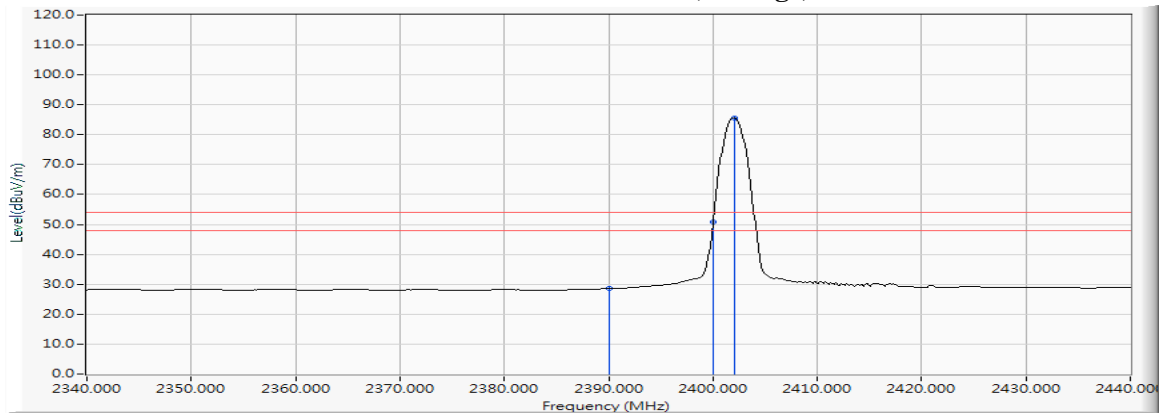

Figure Channel 00: VERTICAL (Average)



Note:

1. All readings above 1GHz are performed with peak and/or average measurements as necessary.
2. Peak measurements: RBW = 1MHz, VBW = 3 MHz, Sweep: Auto.
3. Average measurements: RBW = 1MHz, VBW = 10 Hz, Sweep: Auto.
4. “ * ”, means this data is the worst emission level.
5. Measurement Level = Reading Level + Correction Factor.
6. The average measurement was not performed when the peak measured data is under the limit of average detection.

Product : Tablet PC
 Test Item : Band Edge
 Test Mode : Mode 1: Transmit - 1Mbps (2480MHz)
 Test Date : 2018/01/16

RF Radiated Measurement (Horizontal):

Channel No.	Frequency (MHz)	Correct Factor (dB)	Reading Level (dBμV)	Emission Level (dBμV/m)	Peak Limit (dBμV/m)	Average Limit (dBμV/m)	Result
78 (Peak)	2480.167	12.394	88.925	101.318	--	--	--
78 (Peak)	2483.500	12.403	34.278	46.681	74.00	54.00	Pass
78 (Peak)	2484.370	12.405	34.708	47.113	74.00	54.00	Pass
78 (Average)	2480.022	12.393	72.906	85.299	--	--	--
78 (Average)	2483.500	12.403	20.160	32.563	74.00	54.00	Pass

Figure Channel 78: Horizontal (Peak)

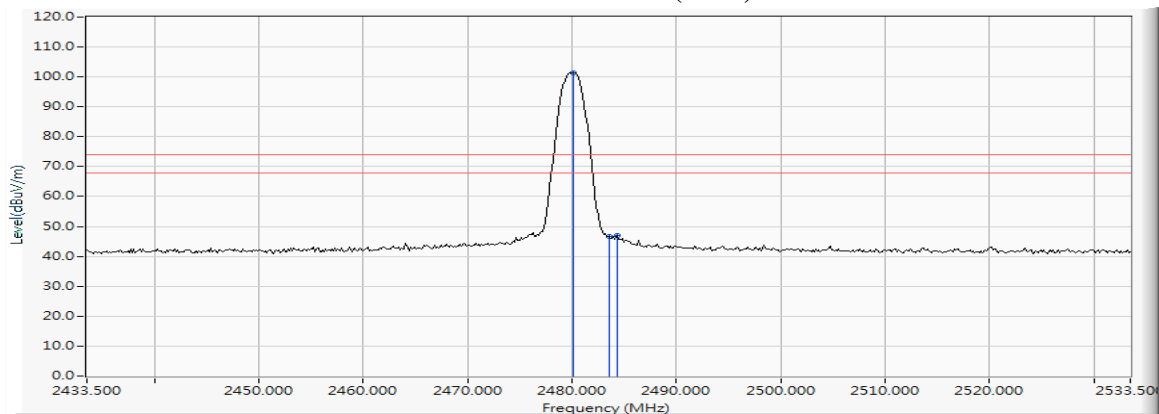
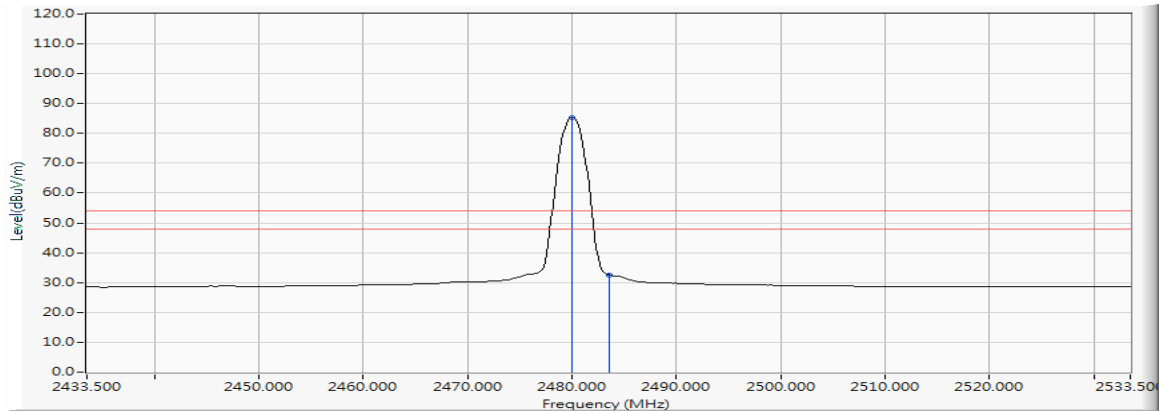

Figure Channel 78: Horizontal (Average)



Note:

1. All readings above 1GHz are performed with peak and/or average measurements as necessary.
2. Peak measurements: RBW = 1MHz, VBW = 3 MHz, Sweep: Auto.
3. Average measurements: RBW = 1MHz, VBW = 10 Hz, Sweep: Auto.
4. “ * ”, means this data is the worst emission level.
5. Measurement Level = Reading Level + Correction Factor.
6. The average measurement was not performed when the peak measured data is under the limit of average detection.

Product : Tablet PC
 Test Item : Band Edge
 Test Mode : Mode 1: Transmit - 1Mbps (2480MHz)
 Test Date : 2018/01/16

RF Radiated Measurement (VERTICAL):

Channel No.	Frequency (MHz)	Correct Factor (dB)	Reading Level (dBμV)	Emission Level (dBμV/m)	Peak Limit (dBμV/m)	Average Limit (dBμV/m)	Result
78 (Peak)	2480.167	12.394	90.304	102.697	--	--	--
78 (Peak)	2483.500	12.403	34.744	47.147	74.00	54.00	Pass
78 (Peak)	2484.225	12.404	35.211	47.616	74.00	54.00	Pass
78 (Average)	2480.022	12.393	74.000	86.393	--	--	--
78 (Average)	2483.500	12.403	20.880	33.283	74.00	54.00	Pass

Figure Channel 78: VERTICAL (Peak)

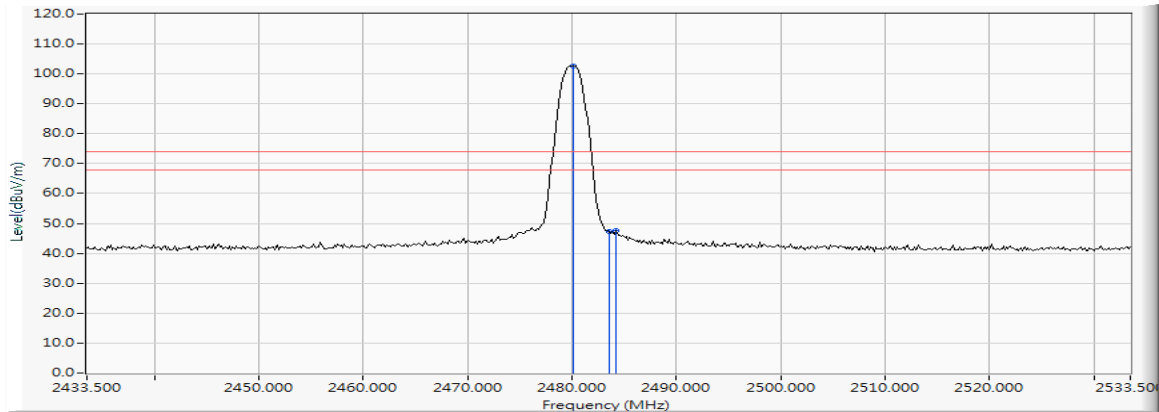
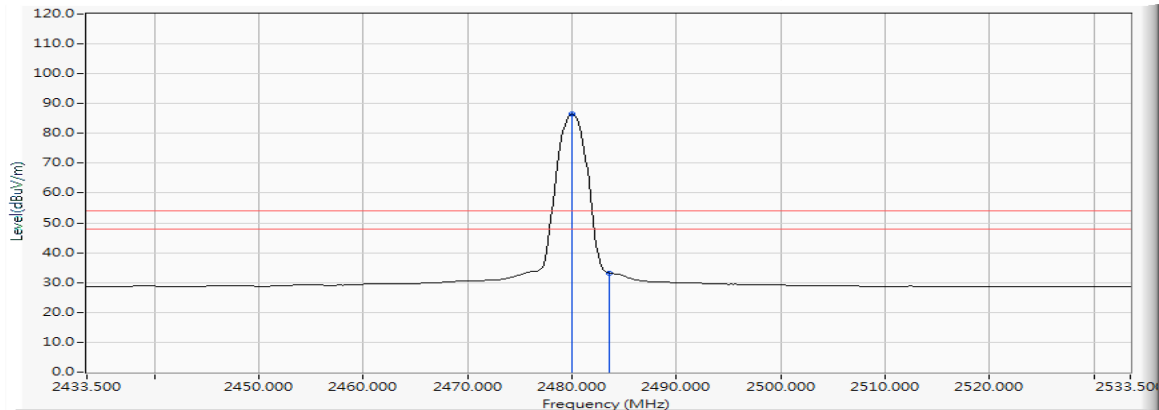

Figure Channel 78: VERTICAL (Average)



Note:

1. All readings above 1GHz are performed with peak and/or average measurements as necessary.
2. Peak measurements: RBW = 1MHz, VBW = 3 MHz, Sweep: Auto.
3. Average measurements: RBW = 1MHz, VBW = 10 Hz, Sweep: Auto.
4. “ * ”, means this data is the worst emission level.
5. Measurement Level = Reading Level + Correction Factor.
6. The average measurement was not performed when the peak measured data is under the limit of average detection.

Product : Tablet PC
 Test Item : Band Edge
 Test Mode : Mode 2: Transmit - 3Mbps (2402MHz)
 Test Date : 2018/01/16

RF Radiated Measurement (Horizontal):

Channel No.	Frequency (MHz)	Correct Factor (dB)	Reading Level (dBμV)	Emission Level (dBμV/m)	Peak Limit (dBμV/m)	Average Limit (dBμV/m)	Result
00 (Peak)	2389.710	12.147	30.826	42.973	74.00	54.00	Pass
00 (Peak)	2390.000	12.148	30.251	42.399	74.00	54.00	Pass
00 (Peak)	2400.000	12.176	61.213	73.389	--	--	Pass
00 (Peak)	2402.029	12.182	87.788	99.969	--	--	--
00 (Average)	2390.000	12.148	16.416	28.564	74.00	54.00	Pass
00 (Average)	2400.000	12.176	42.761	54.937	--	--	Pass
00 (Average)	2402.029	12.182	69.671	81.852	--	--	--

Figure Channel 00: Horizontal (Peak)

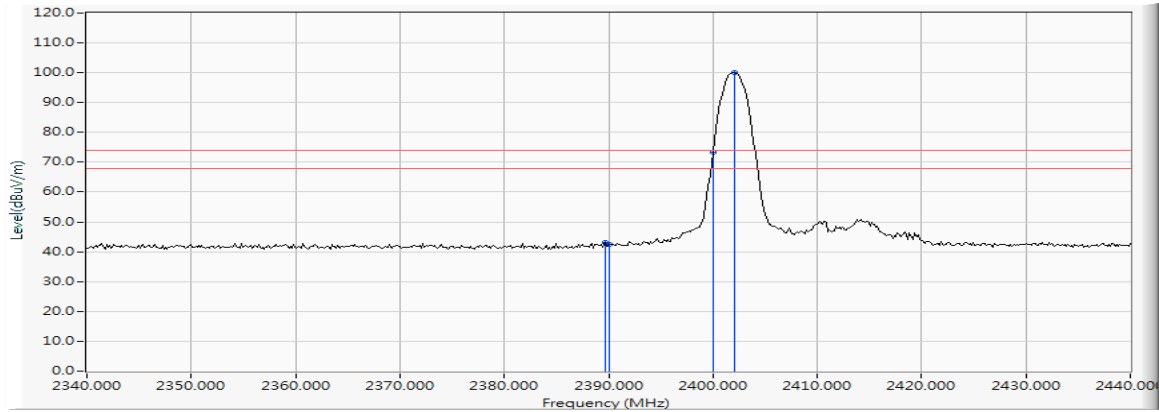
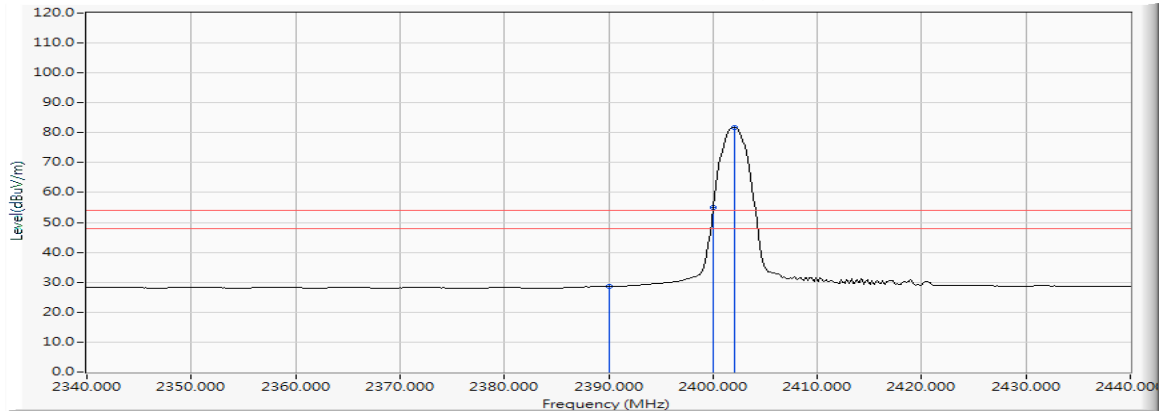

Figure Channel 00: Horizontal (Average)



Note:

1. All readings above 1GHz are performed with peak and/or average measurements as necessary.
2. Peak measurements: RBW = 1MHz, VBW = 3 MHz, Sweep: Auto.
3. Average measurements: RBW = 1MHz, VBW = 10 Hz, Sweep: Auto.
4. “ * ”, means this data is the worst emission level.
5. Measurement Level = Reading Level + Correction Factor.
6. The average measurement was not performed when the peak measured data is under the limit of average detection.

Product : Tablet PC
 Test Item : Band Edge
 Test Mode : Mode 2: Transmit - 3Mbps (2402MHz)
 Test Date : 2018/01/16

RF Radiated Measurement (VERTICAL):

Channel No.	Frequency (MHz)	Correct Factor (dB)	Reading Level (dBµV)	Emission Level (dBµV/m)	Peak Limit (dBµV/m)	Average Limit (dBµV/m)	Result
00 (Peak)	2387.246	12.140	30.112	42.252	74.00	54.00	Pass
00 (Peak)	2390.000	12.148	29.179	41.327	74.00	54.00	Pass
00 (Peak)	2400.000	12.176	61.907	74.083	--	--	Pass
00 (Peak)	2402.029	12.182	88.492	100.673	--	--	--
00 (Average)	2390.000	12.148	16.427	28.575	74.00	54.00	Pass
00 (Average)	2400.000	12.176	43.287	55.463	--	--	Pass
00 (Average)	2402.029	12.182	70.249	82.430	--	--	--

Figure Channel 00: VERTICAL (Peak)

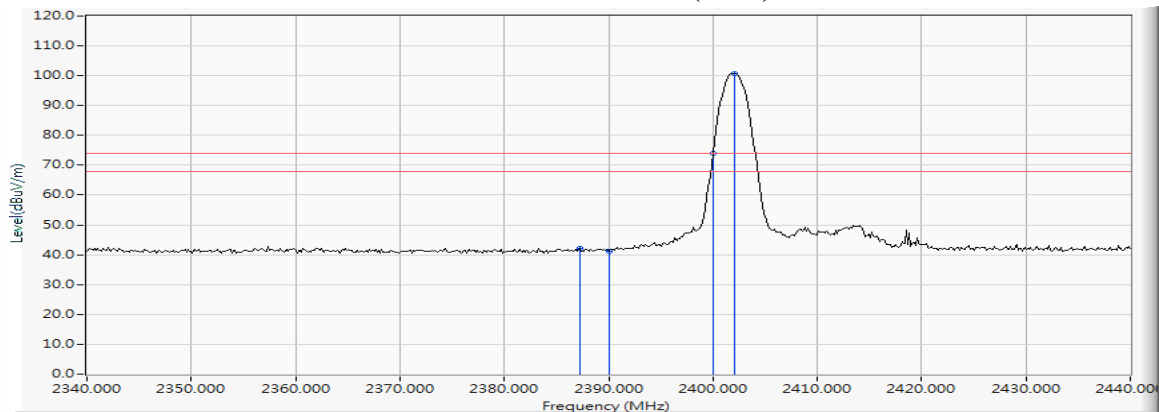
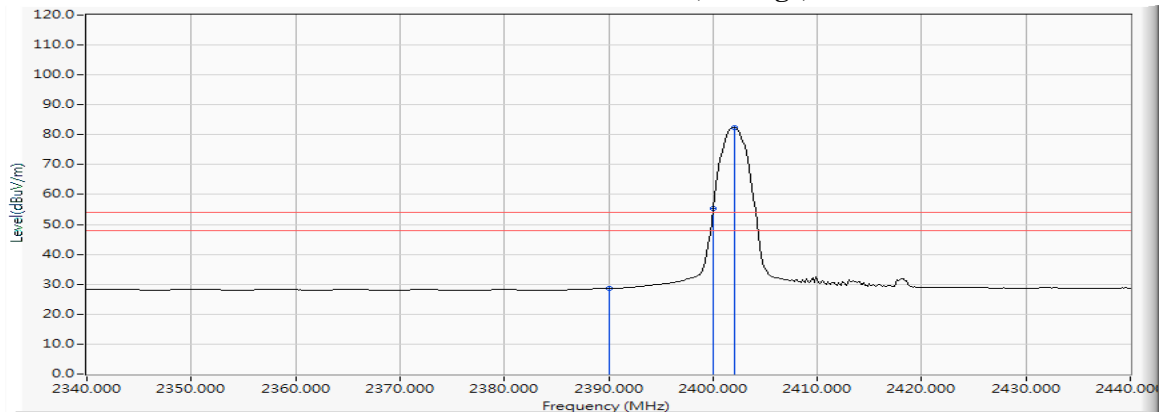

Figure Channel 00: VERTICAL (Average)



Note:

1. All readings above 1GHz are performed with peak and/or average measurements as necessary.
2. Peak measurements: RBW = 1MHz, VBW = 3 MHz, Sweep: Auto.
3. Average measurements: RBW = 1MHz, VBW = 10 Hz, Sweep: Auto.
4. “ * ”, means this data is the worst emission level.
5. Measurement Level = Reading Level + Correction Factor.
6. The average measurement was not performed when the peak measured data is under the limit of average detection.

Product : Tablet PC
 Test Item : Band Edge
 Test Mode : Mode 2: Transmit - 3Mbps (2480MHz)
 Test Date : 2018/01/16

RF Radiated Measurement (Horizontal):

Channel No.	Frequency (MHz)	Correct Factor (dB)	Reading Level (dB μ V)	Emission Level (dB μ V/m)	Peak Limit (dB μ V/m)	Average Limit (dB μ V/m)	Result
78 (Peak)	2480.022	12.393	87.507	99.900	--	--	--
78 (Peak)	2483.500	12.403	36.392	48.795	74.00	54.00	Pass
78 (Average)	2480.022	12.393	69.380	81.773	--	--	--
78 (Average)	2483.500	12.403	20.795	33.198	74.00	54.00	Pass

Figure Channel 00: Horizontal (Peak)

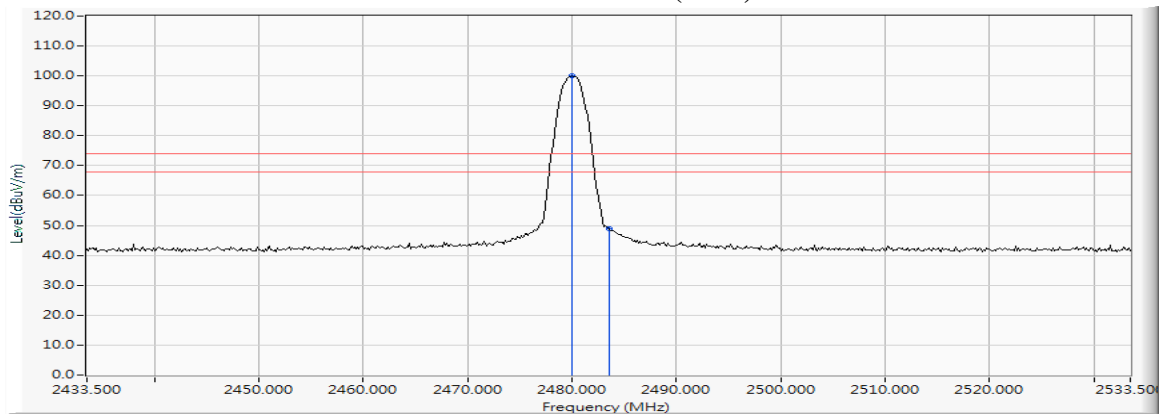
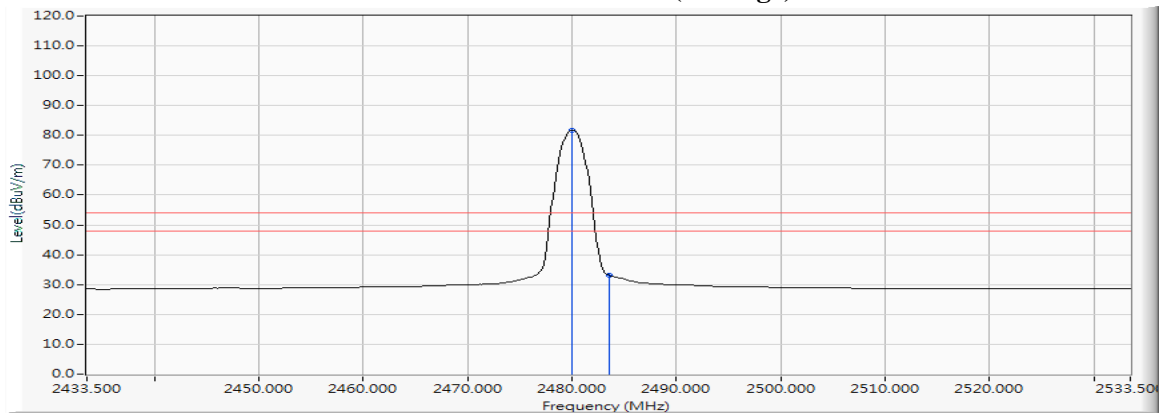

Figure Channel 00: Horizontal (Average)



Note:

1. All readings above 1GHz are performed with peak and/or average measurements as necessary.
2. Peak measurements: RBW = 1MHz, VBW = 3 MHz, Sweep: Auto.
3. Average measurements: RBW = 1MHz, VBW = 10 Hz, Sweep: Auto.
4. “ * ”, means this data is the worst emission level.
5. Measurement Level = Reading Level + Correction Factor.
6. The average measurement was not performed when the peak measured data is under the limit of average detection.

Product : Tablet PC
 Test Item : Band Edge
 Test Mode : Mode 2: Transmit - 3Mbps (2480MHz)
 Test Date : 2018/01/16

RF Radiated Measurement (VERTICAL):

Channel No.	Frequency (MHz)	Correct Factor (dB)	Reading Level (dBμV)	Emission Level (dBμV/m)	Peak Limit (dBμV/m)	Average Limit (dBμV/m)	Result
78 (Peak)	2480.022	12.393	89.052	101.445	--	--	--
78 (Peak)	2483.500	12.403	37.205	49.608	74.00	54.00	Pass
78 (Peak)	2483.645	12.403	37.936	50.339	74.00	54.00	Pass
78 (Average)	2480.022	12.393	70.617	83.010	--	--	--
78 (Average)	2483.500	12.403	21.458	33.861	74.00	54.00	Pass

Figure Channel 78: VERTICAL (Peak)

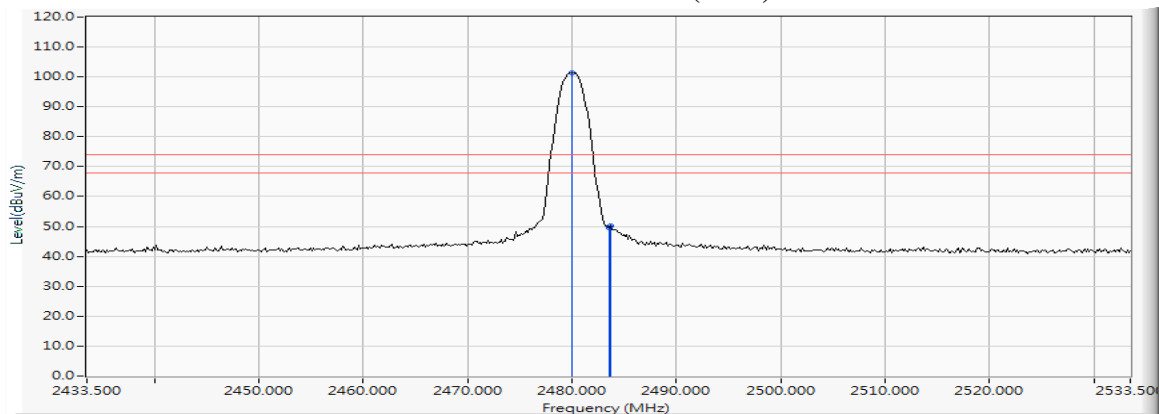
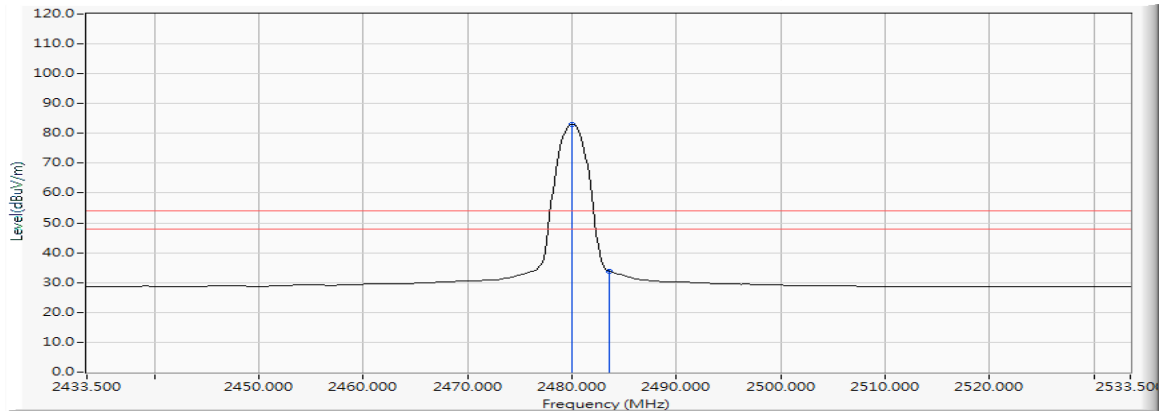

Figure Channel 78: VERTICAL (Average)



Note:

1. All readings above 1GHz are performed with peak and/or average measurements as necessary.
2. Peak measurements: RBW = 1MHz, VBW = 3 MHz, Sweep: Auto.
3. Average measurements: RBW = 1MHz, VBW = 10 Hz, Sweep: Auto.
4. “ * ”, means this data is the worst emission level.
5. Measurement Level = Reading Level + Correction Factor.
6. The average measurement was not performed when the peak measured data is under the limit of average detection.

Product : Tablet PC
 Test Item : Band Edge
 Test Mode : Mode 1: Transmit - 1Mbps(Hopping off)

Measurement Level Δ (dB)	Result
> 20	PASS

Figure Channel 00:

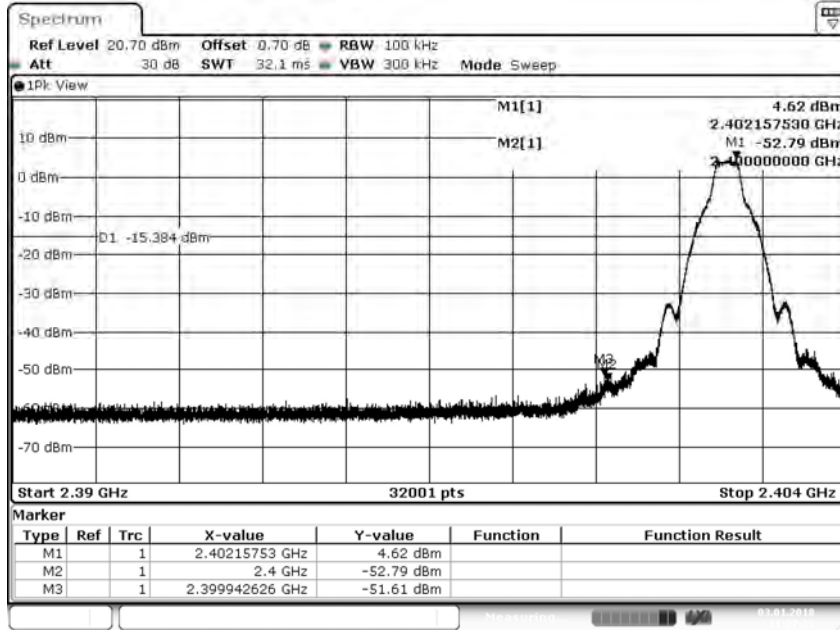

Date: 3. JAN 2018 11:37:23

Figure Channel 78:

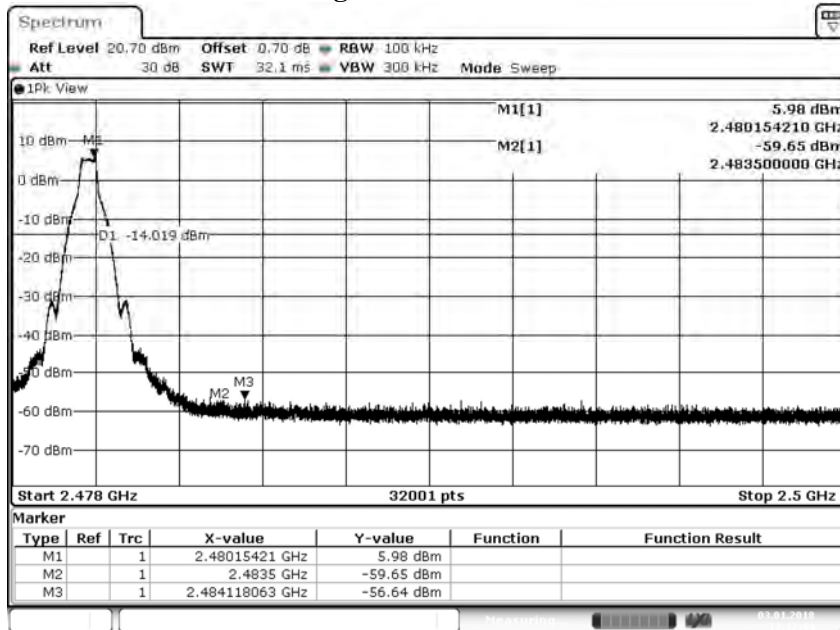

Date: 3. JAN 2018 13:12:44

Product : Tablet PC
 Test Item : Band Edge
 Test Mode : Mode 2: Transmit - 3Mbps (Hopping off)

Measurement Level Δ (dB)	Result
> 20	PASS

Figure Channel 00:

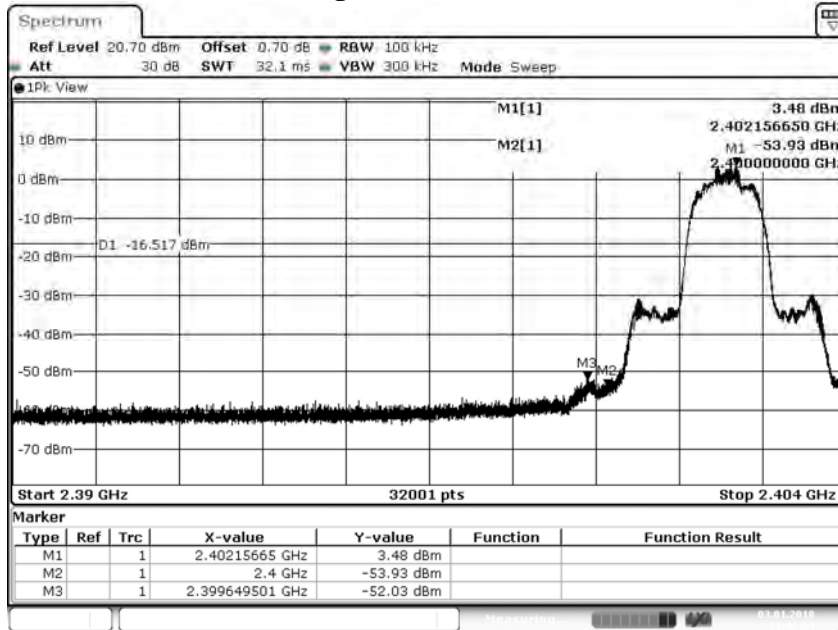

Date: 3. JAN 2018 13:42:24

Figure Channel 78:

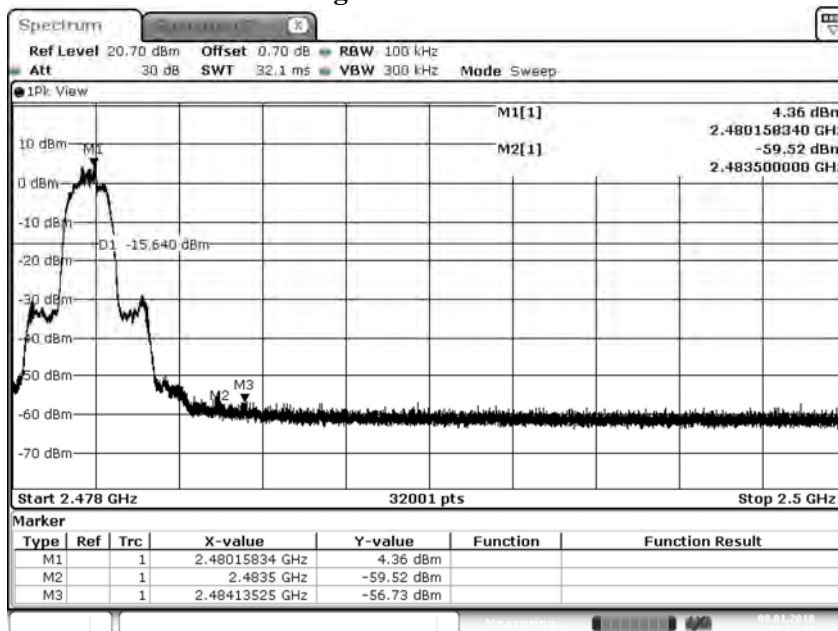

Date: 8. JAN 2018 10:11:49

Product : Tablet PC
 Test Item : Band Edge
 Test Mode : Mode 1: Transmit - 1Mbps(Hopping on)

Measurement Level Δ (dB)	Result
> 20	PASS

Figure Channel Hopping:

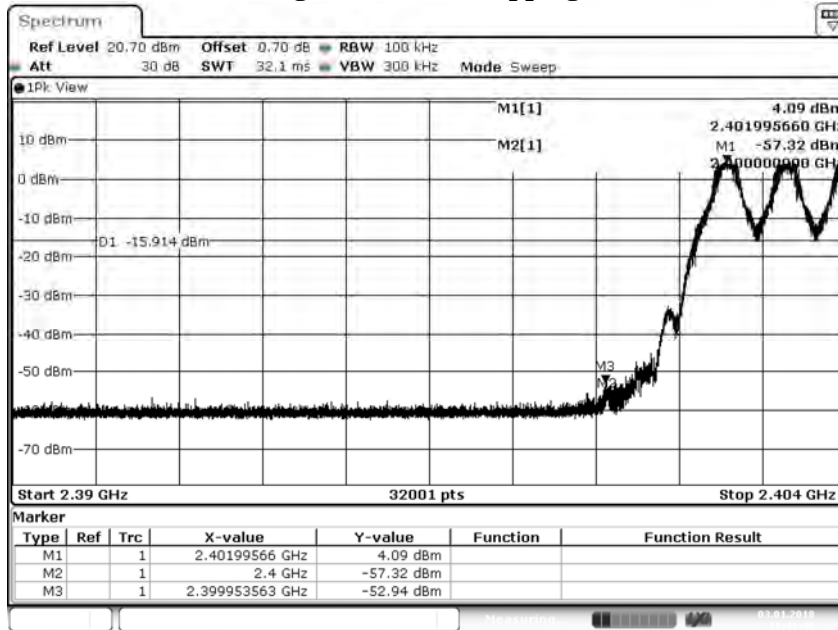

Date: 3. JAN 2018 11:41:48

Figure Channel Hopping:

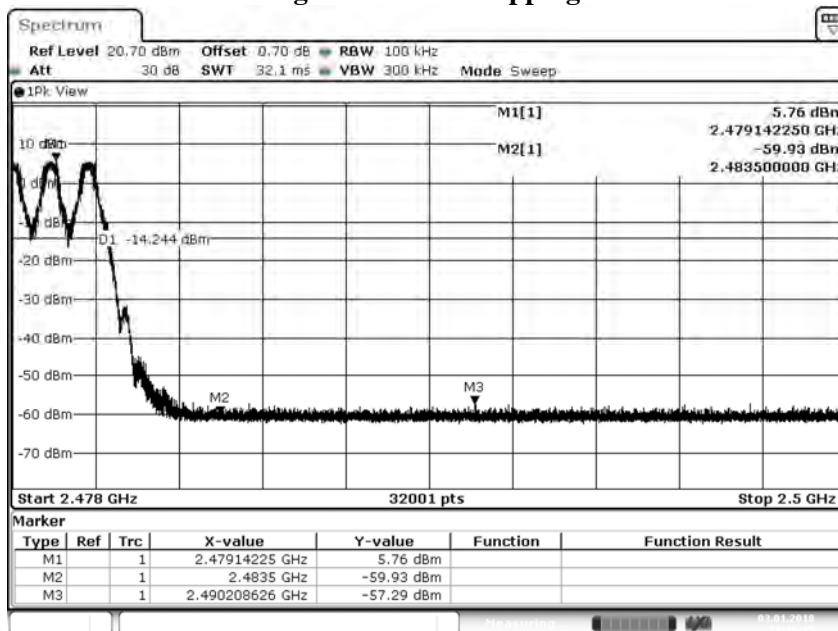

Date: 3. JAN 2018 13:16:15

Product : Tablet PC
 Test Item : Band Edge
 Test Mode : Mode 2: Transmit - 3Mbps (Hopping on)

Measurement Level	Result
Δ (dB)	
> 20	PASS

Figure Channel Hopping:

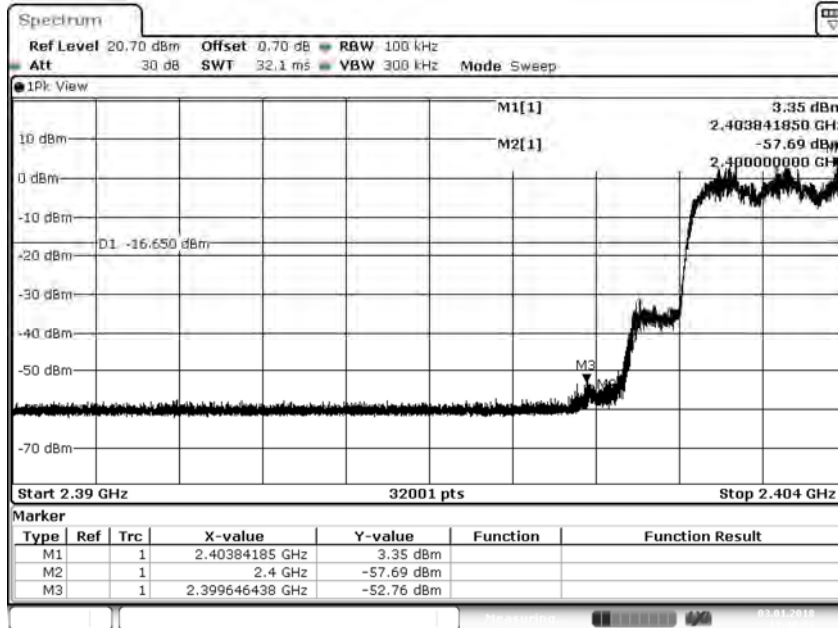

Date: 3. JAN 2018 13:48:03

Figure Channel Hopping:

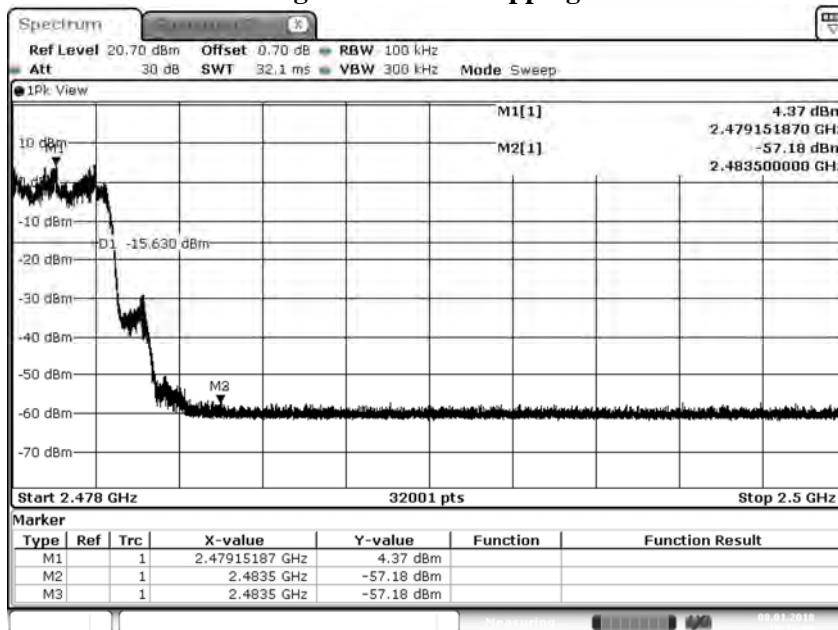

Date: 8. JAN 2018 10:16:07

7. Channel Number

7.1. Test Setup

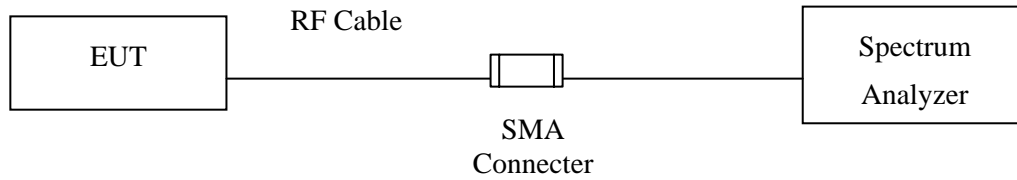

7.2. Limit

Frequency hopping systems operating in the 2400-2483.5 MHz bands shall use at least 75 hopping frequencies.

7.3. Test Procedure

The EUT was setup to ANSI C63.4, 2014; tested to FHSS test procedure of FCC Public Notice DA 00-705 for compliance to FCC 47CFR 15.247 requirements.

7.4. Uncertainty

N/A

7.5. Test Result of Channel Number

Product : Tablet PC
 Test Item : Channel Number
 Test Mode : Mode 1: Transmit - 1Mbps

Frequency Range (MHz)	Measurement (Hopping Channel)	Required Limit (Hopping Channel)	Result
2402 ~ 2480	79	>75	Pass

2402-2421MHz

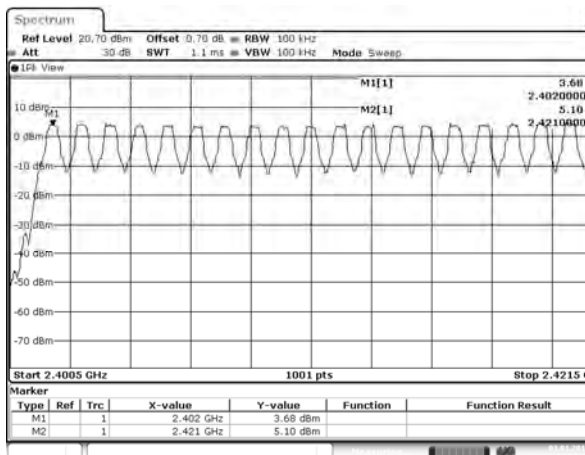

Date: 3.JAN.2018 13:23:45

2422-2441MHz

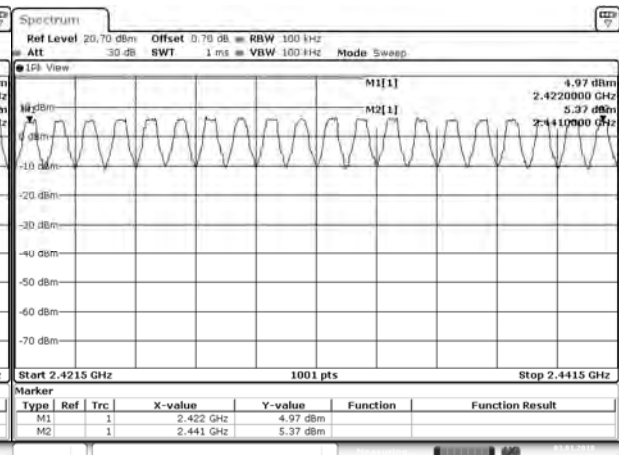

Date: 3.JAN.2018 13:24:51

2442-2461MHz

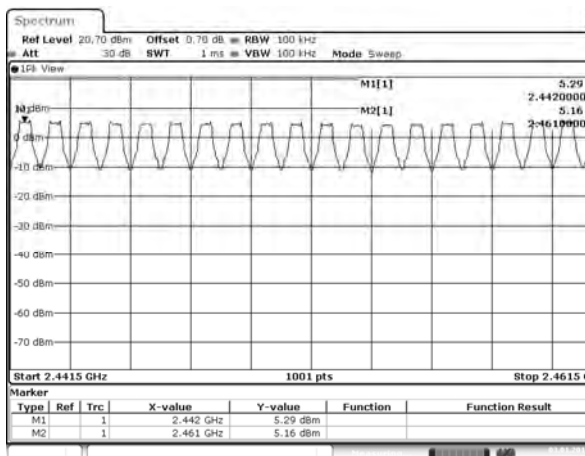

Date: 3.JAN.2018 13:29:29

2462-2480MHz

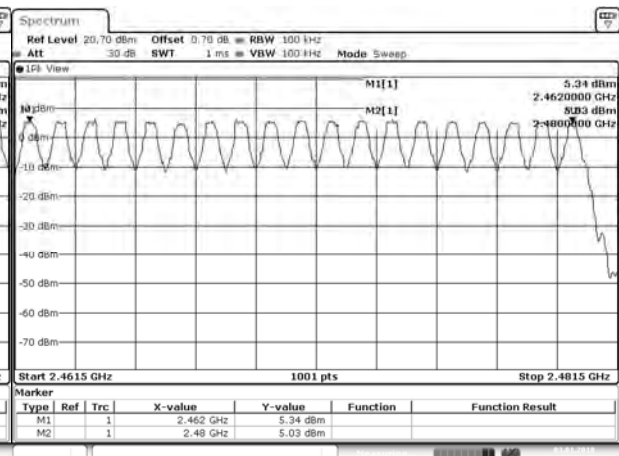

Date: 3.JAN.2018 13:30:47

Product : Tablet PC
 Test Item : Channel Number
 Test Mode : Mode 2: Transmit - 3Mbps

Frequency Range (MHz)	Measurement (Hopping Channel)	Required Limit (Hopping Channel)	Result
2402 ~ 2480	79	>75	Pass

2402-2421MHz

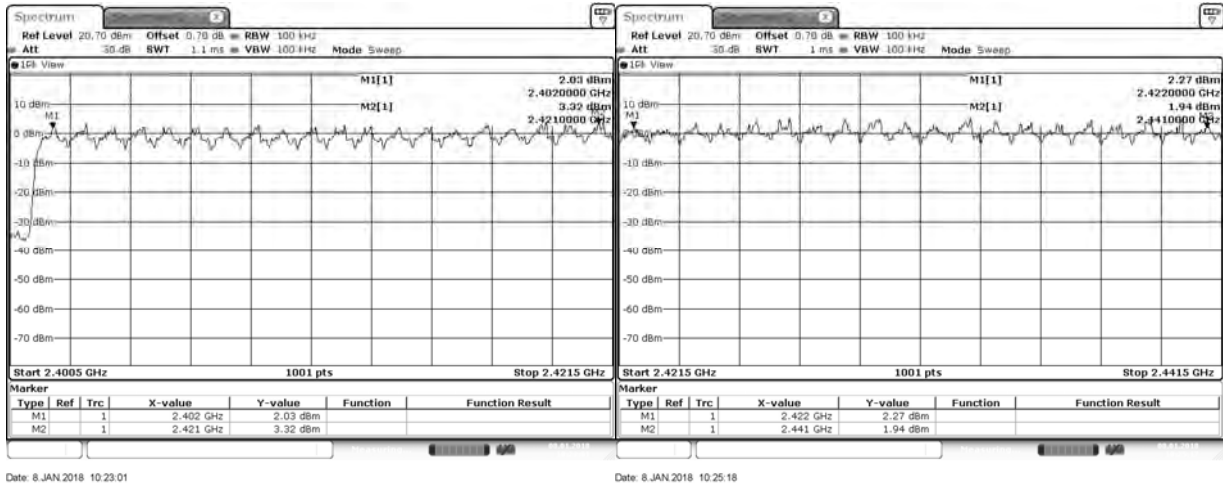

Date: 8.JAN.2018 10:23:01

2422-2441MHz

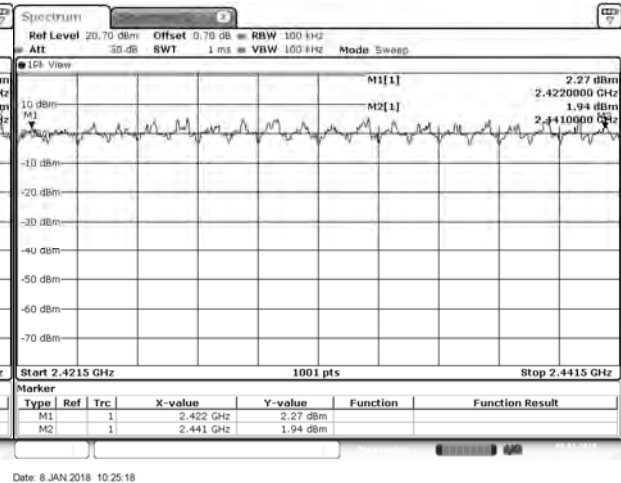

Date: 8.JAN.2018 10:25:18

2442-2461MHz

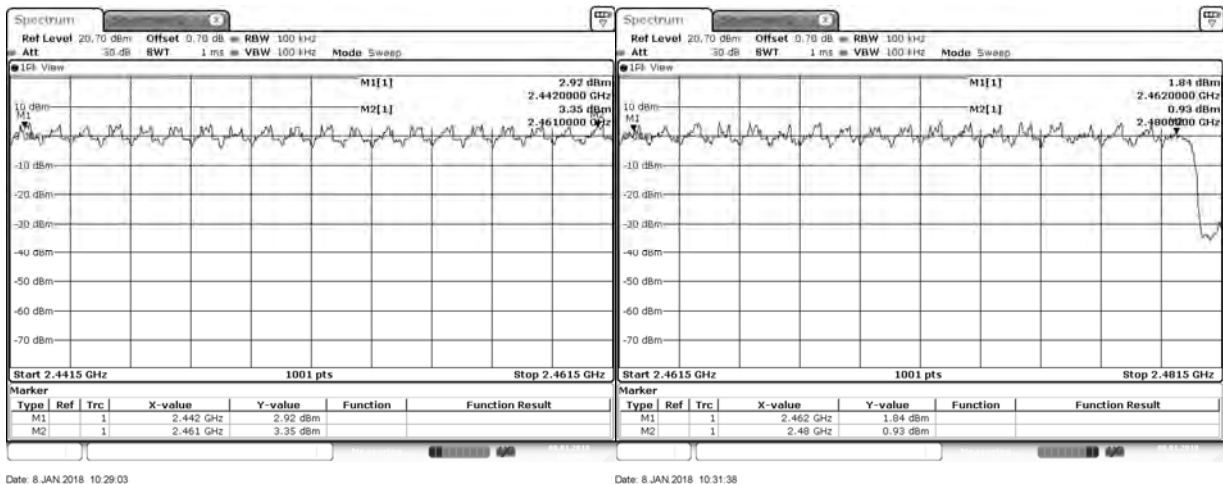

Date: 8.JAN.2018 10:29:03

2462-2480MHz

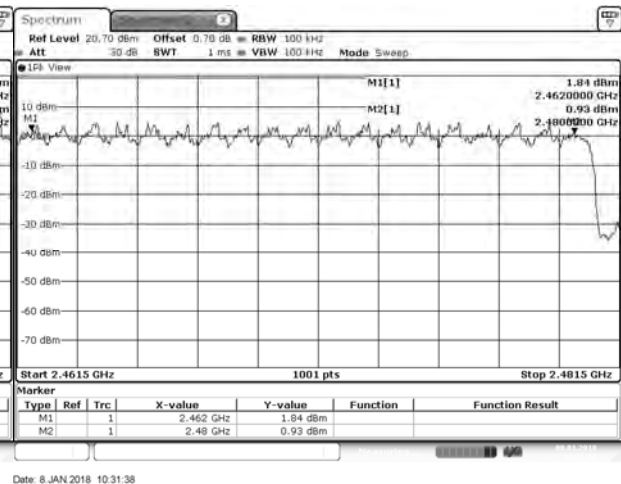

Date: 8.JAN.2018 10:31:38

8. Channel Separation

8.1. Test Setup

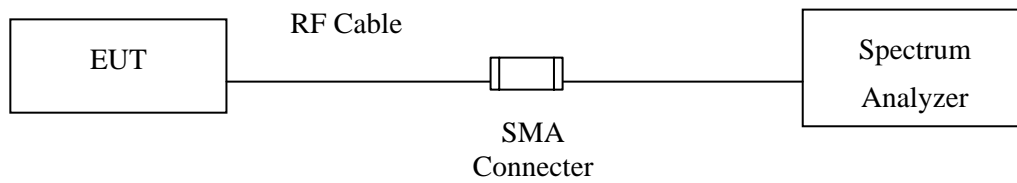

8.2. Limit

Frequency hopping systems shall have hopping channel carrier frequencies separated by a minimum of 25 kHz or the 20 dB bandwidth of the hopping channel, whichever is greater.

8.3. Test Procedure

The EUT was setup to ANSI C63.4, 2014; tested to FHSS test procedure of FCC Public Notice DA 00-705 for compliance to FCC 47CFR 15.247 requirements.

8.4. Uncertainty

$\pm 279.2\text{Hz}$

8.5. Test Result of Channel Separation

Product : Tablet PC
 Test Item : Channel Separation
 Test Mode : Mode 1: Transmit - 1Mbps

Channel No.	Frequency (MHz)	Measurement Level (kHz)	Limit (kHz)	Limit of (2/3)*20dB Bandwidth (kHz)	Result
00	2402	1000	>25 kHz	642.0	Pass
39	2441	1000	>25 kHz	644.0	Pass
78	2480	1000	>25 kHz	646.0	Pass

NOTE: The 20dB Bandwidth is refer to section 10.

Channel 00 (2402MHz)

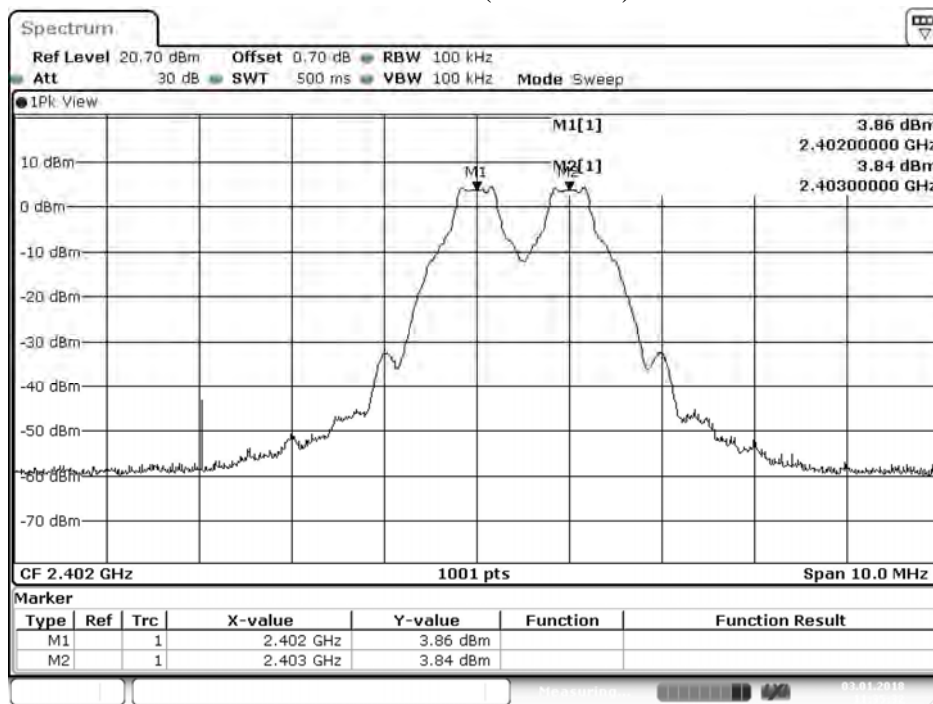

Date: 3.JAN.2018 11:35:32

Channel 39 (2441MHz)

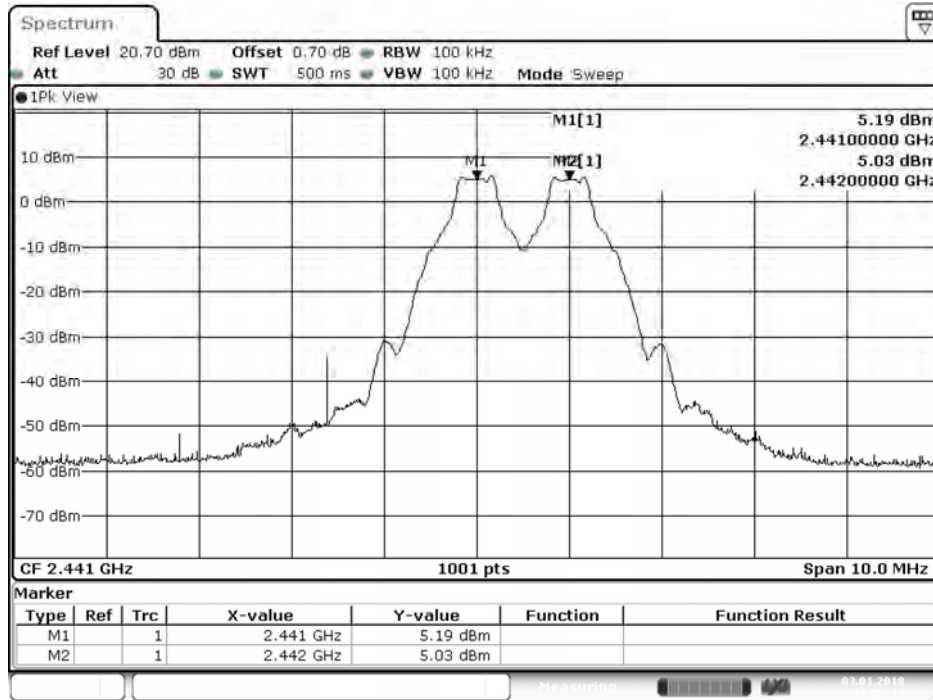

Date: 3.JAN.2018 11:55:14

Channel 78 (2480MHz)

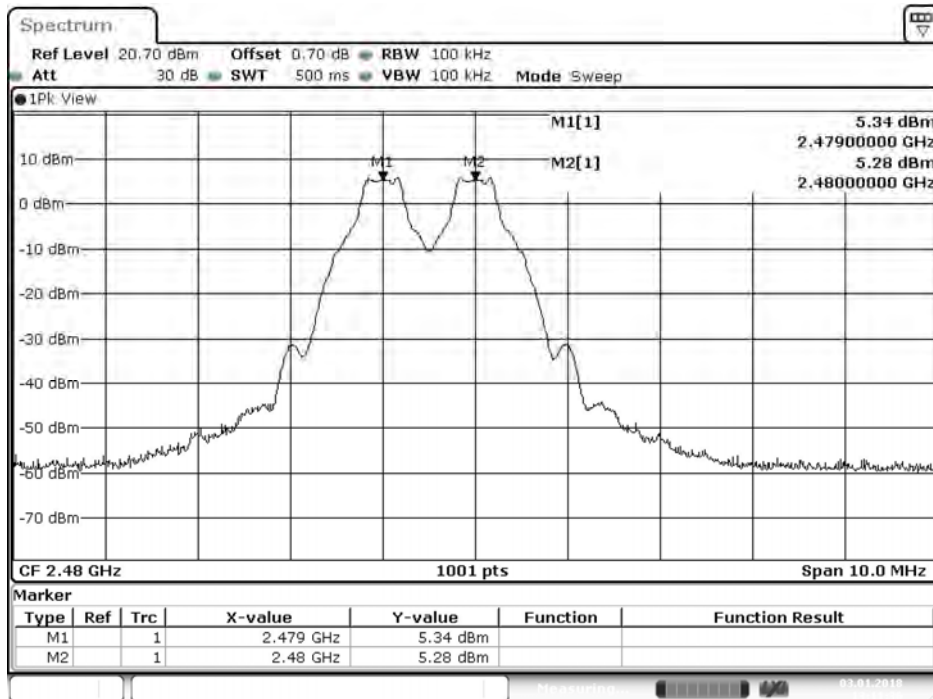

Date: 3.JAN.2018 13:11:36

Product : Tablet PC
 Test Item : Channel Separation
 Test Mode : Mode 2: Transmit - 3Mbps

Channel No.	Frequency (MHz)	Measurement Level (kHz)	Limit (kHz)	Limit of (2/3)*20dB Bandwidth (kHz)	Result
00	2402	1000	>25 kHz	858.0	Pass
39	2441	1000	>25 kHz	862.0	Pass
78	2480	1000	>25 kHz	862.0	Pass

NOTE: The 20dB Bandwidth is refer to section 10.

Channel 00 (2402MHz)

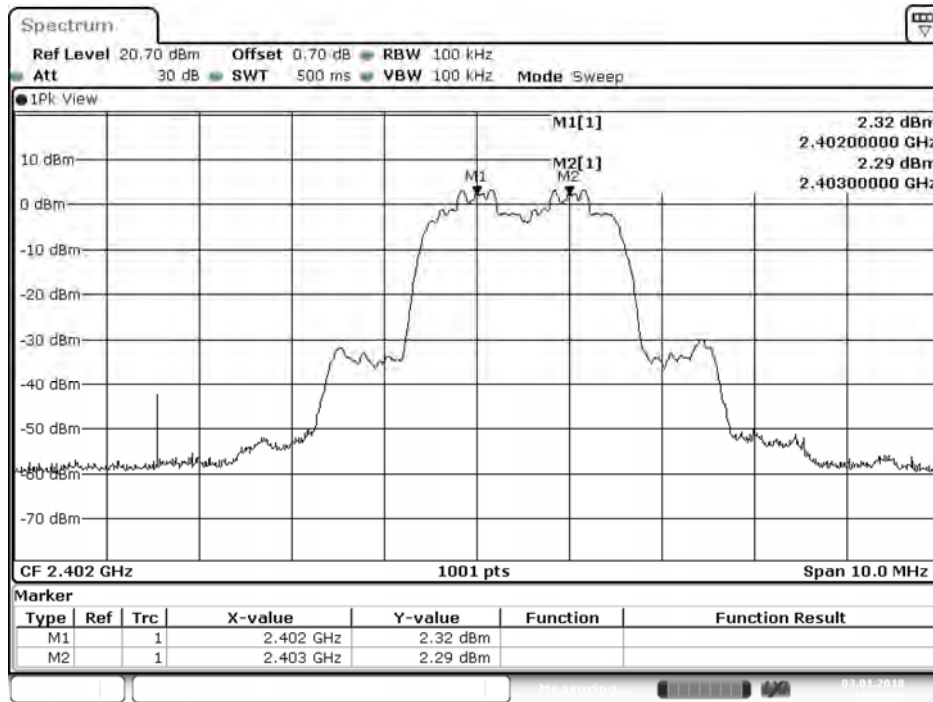

Date: 3.JAN.2018 13:40:59

Channel 39 (2441MHz)

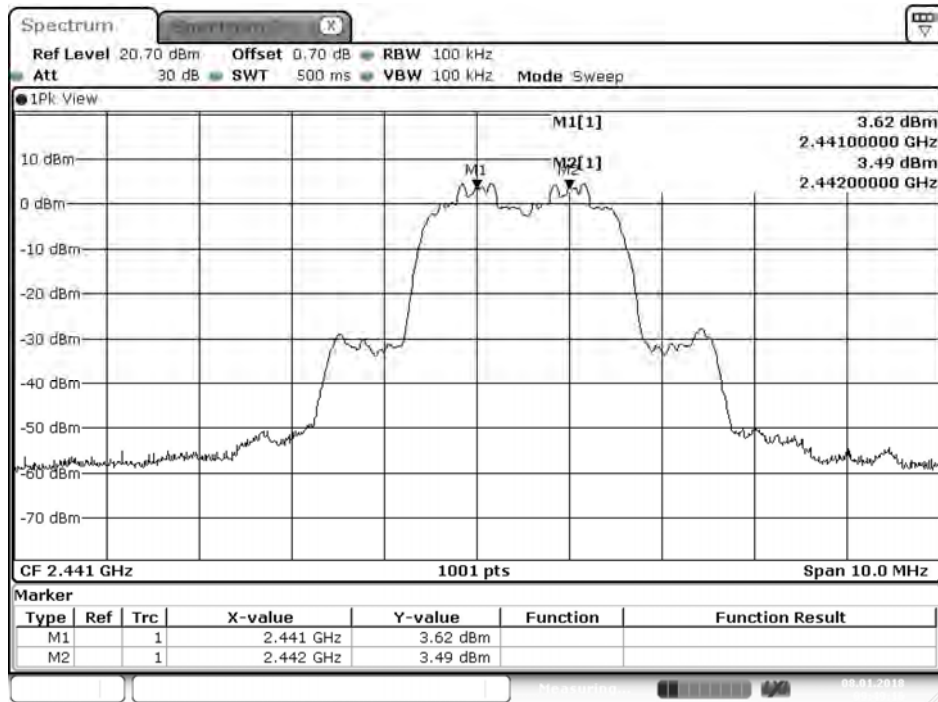

Date: 8.JAN.2018 09:49:15

Channel 78 (2480MHz)

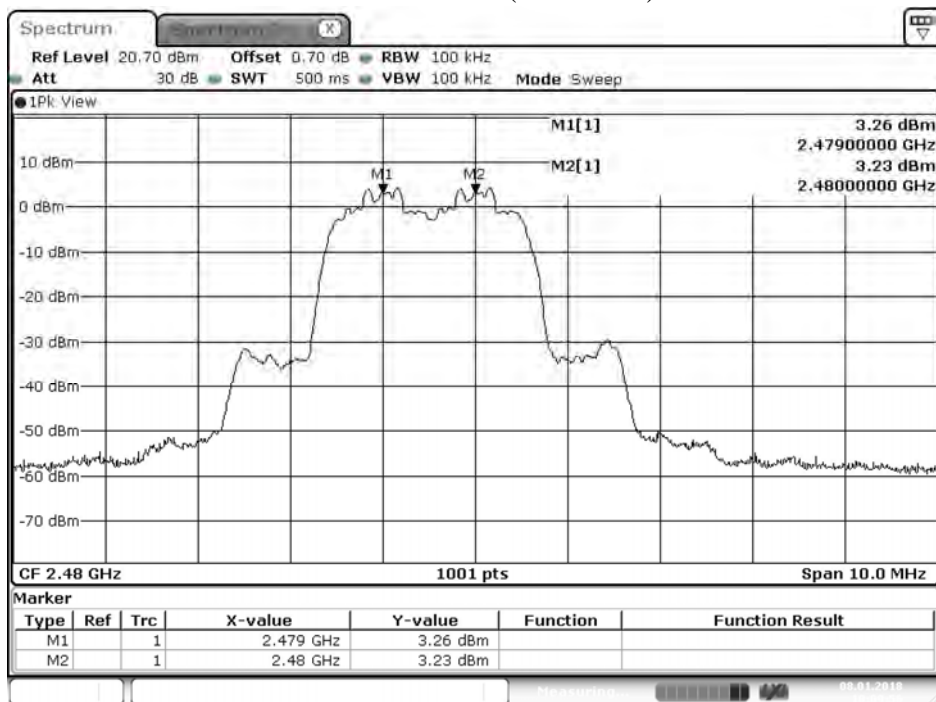

Date: 8.JAN.2018 10:09:56

9. Dwell Time

9.1. Test Setup

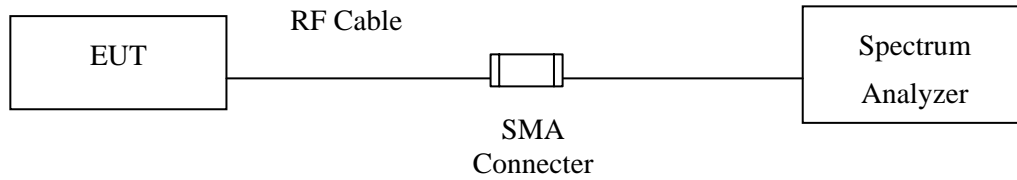

9.2. Limit

The average time of occupancy on any channel shall not be greater than 0.4 seconds within a period of 0.4 seconds multiplied by the number of hopping channels employed.

9.3. Test Procedure

The EUT was setup to ANSI C63.4, 2014; tested to FHSS test procedure of FCC Public Notice DA 00-705 for compliance to FCC 47CFR 15.247 requirements.

9.4. Uncertainty

$\pm 2.31\text{msec}$

9.5. Test Result of Dwell Time

Product : Tablet PC
 Test Item : Dwell Time
 Test Mode : Mode 1: Transmit - 1Mbps (Channel 00,39,78)

Frequency (MHz)	Time slot length (ms)	Hopping of Number	Sweep time (ms)	Duty cycle	Dwell Time (Sec)	Limit (Sec)	Result
2402	2.867	13	50	0.75	0.298	0.4	Pass
2441	2.867	13	50	0.75	0.298	0.4	Pass
2480	2.867	13	50	0.75	0.298	0.4	Pass

Duty cycle = ((Time slot length(ms)*Hopping of Number) / Sweep time (ms)

Dwell time = (Duty cycle /79) * (79*0.4)

CH 00 Hopping of Number

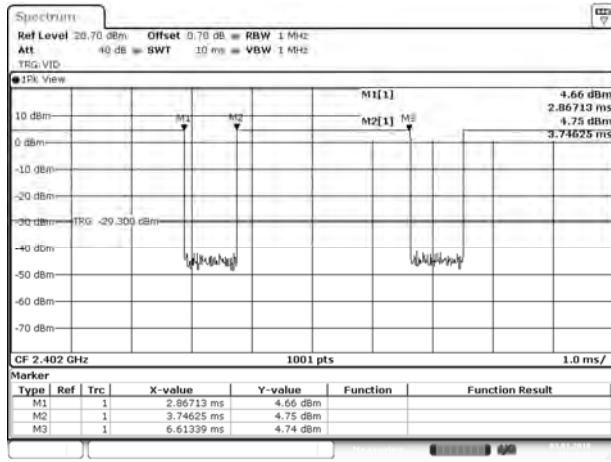

Date: 3.JAN.2018 11:44:19

CH 00 Time slot length

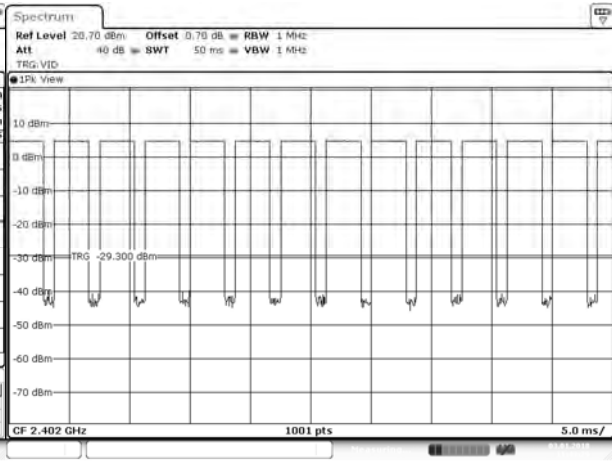

Date: 3.JAN.2018 11:43:30

CH39 Hopping of Number

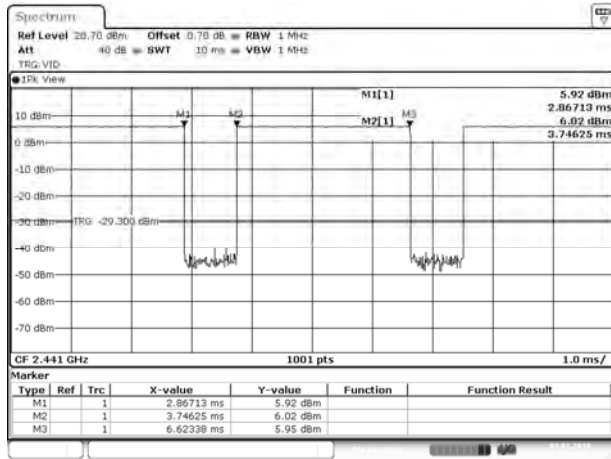

Date: 3.JAN.2018 11:59:22

CH 39 Time slot length

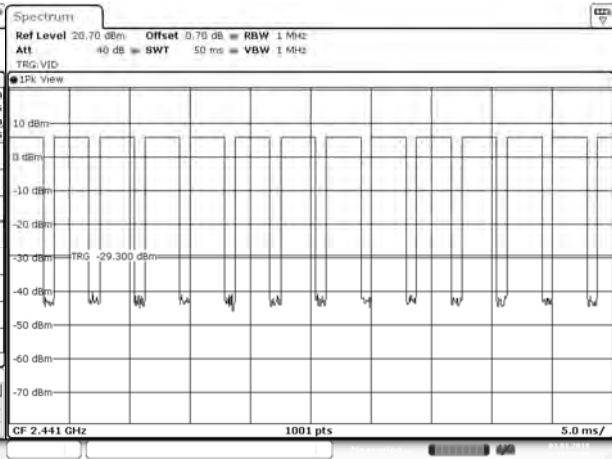

Date: 3.JAN.2018 11:58:33

CH 78 Hopping of Number

CH 78 Time slot length

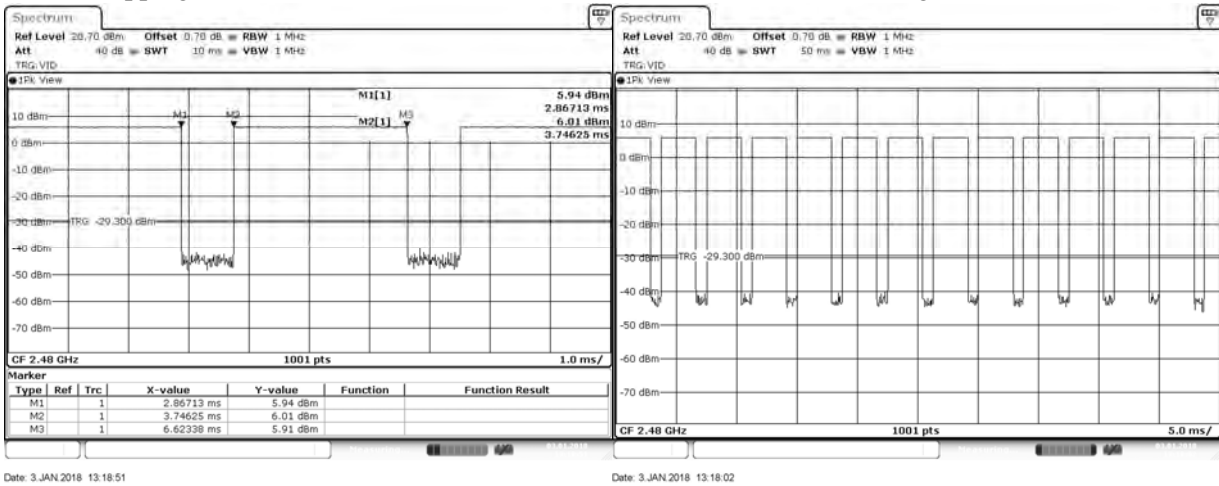

Note:

The dwell times of the packet type of DH1, DH3, and DH5 are tested. Only the worst case is shown on the report.

Product : Tablet PC
 Test Item : Dwell Time
 Test Mode : Mode 2: Transmit - 3Mbps (Channel 00,39,78)

Frequency (MHz)	Time slot length (ms)	Hopping of Number	Sweep time (ms)	Duty cycle	Dwell Time (Sec)	Limit (Sec)	Result
2402	2.877	13	50	0.75	0.299	0.4	Pass
2441	2.877	13	50	0.75	0.299	0.4	Pass
2480	2.877	13	50	0.75	0.299	0.4	Pass

Duty cycle = ((Time slot length(ms)*Hopping of Number) / Sweep time (ms))

Dwell time = (Duty cycle / 79) * (79*0.4)

CH 00 Hopping of Number

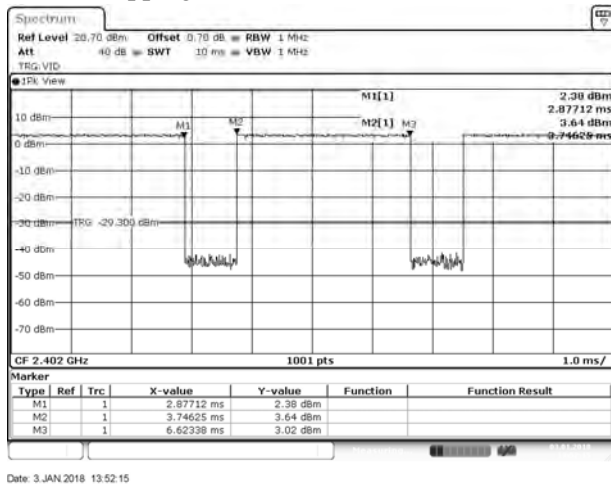

CH 00 Time slot length

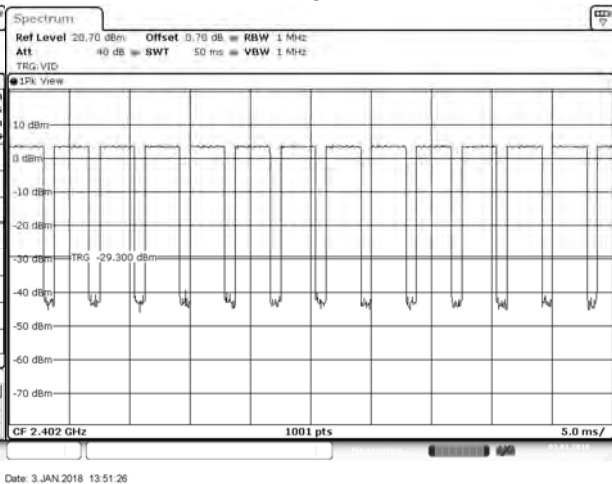

CH39 Hopping of Number

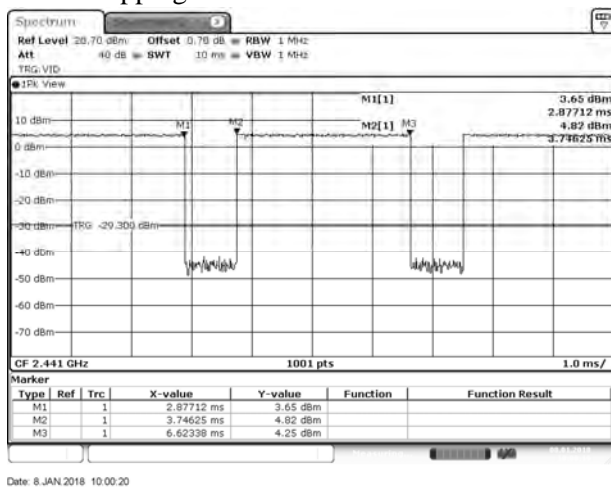

CH 39 Time slot length

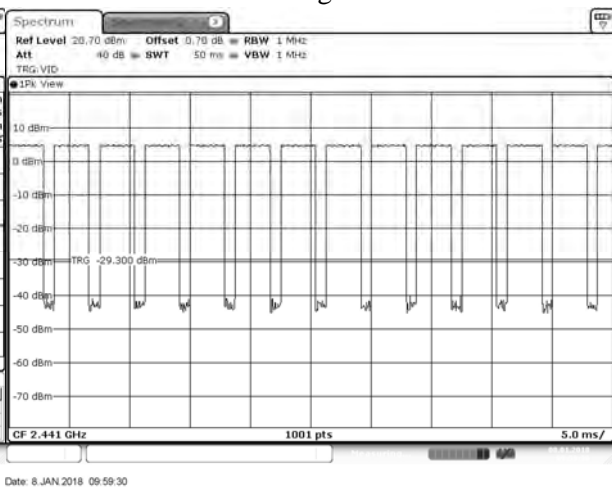

CH 78 Hopping of Number

CH 78 Time slot length

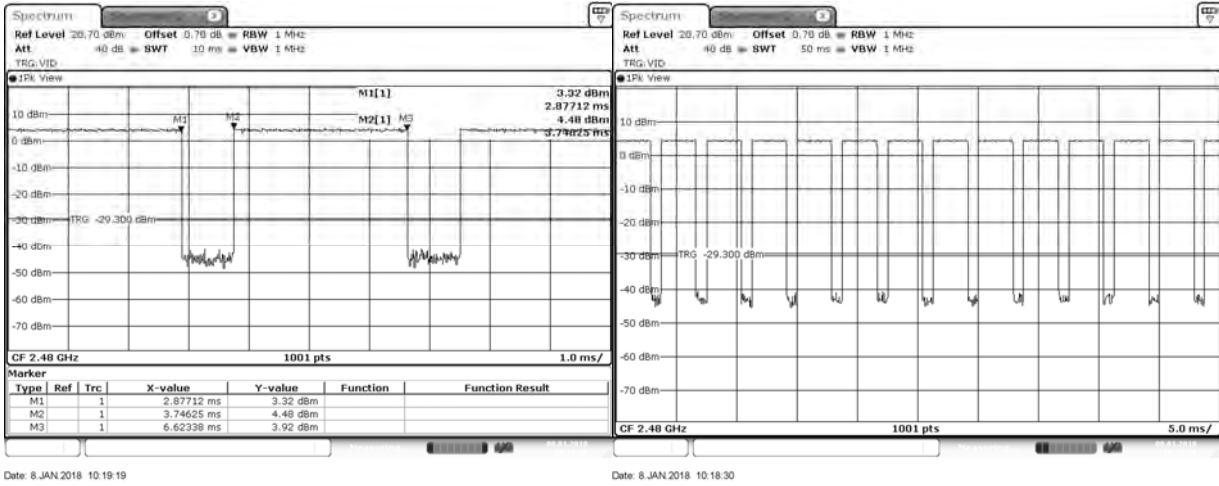

Note:

The dwell times of the packet type of DH1, DH3, and DH5 are tested. Only the worst case is shown on the report.

10. Occupied Bandwidth

10.1. Test Setup

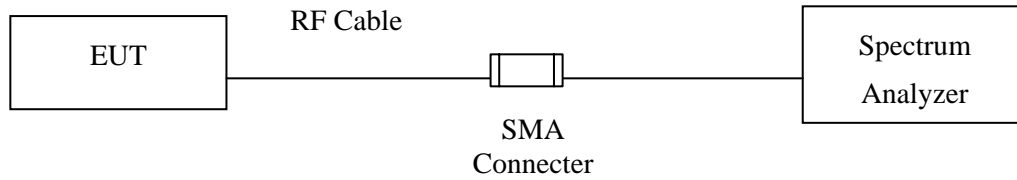

10.2. Limits

N/A

10.3. Test Procedure

The EUT was setup to ANSI C63.4, 2014; tested to FHSS test procedure of FCC Public Notice DA 00-705 for compliance to FCC 47CFR 15.247 requirements.

10.4. Uncertainty

$\pm 279.2\text{Hz}$

10.5. Test Result of Occupied Bandwidth

Product : Tablet PC
 Test Item : Occupied Bandwidth Data
 Test Mode : Mode 1: Transmit - 1Mbps

Channel No.	Frequency (MHz)	Measurement Level (kHz)	Required Limit (kHz)	Result
00	2402	963	--	NA
39	2441	966	--	NA
78	2480	969	--	NA

Figure Channel 00:

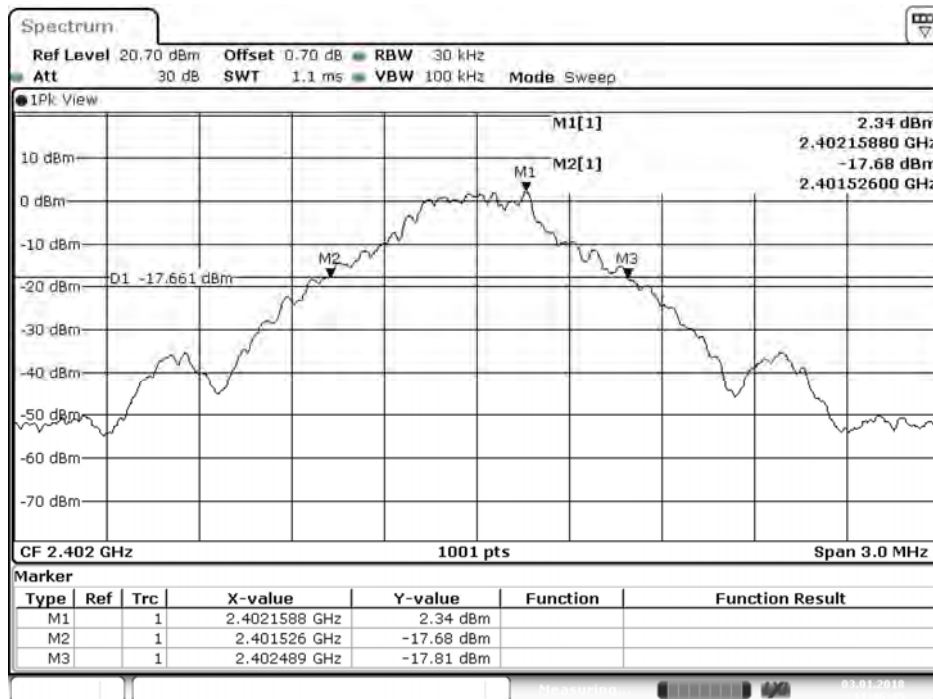

Date: 3.JAN.2018 11:46:46

Figure Channel 39:

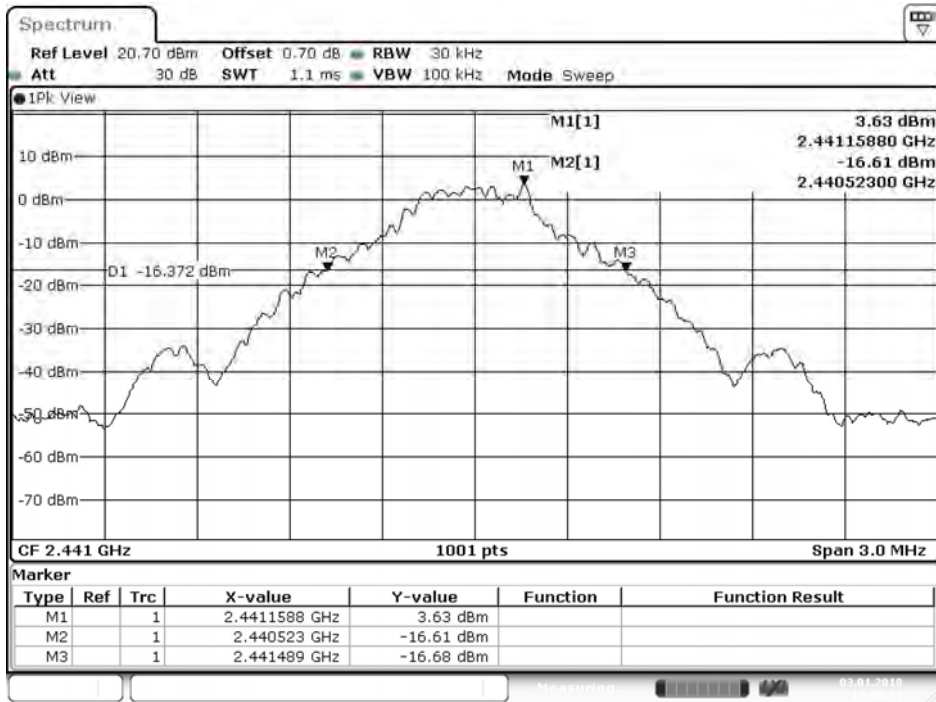

Date: 3.JAN.2018 12:00:22

Figure Channel 78:

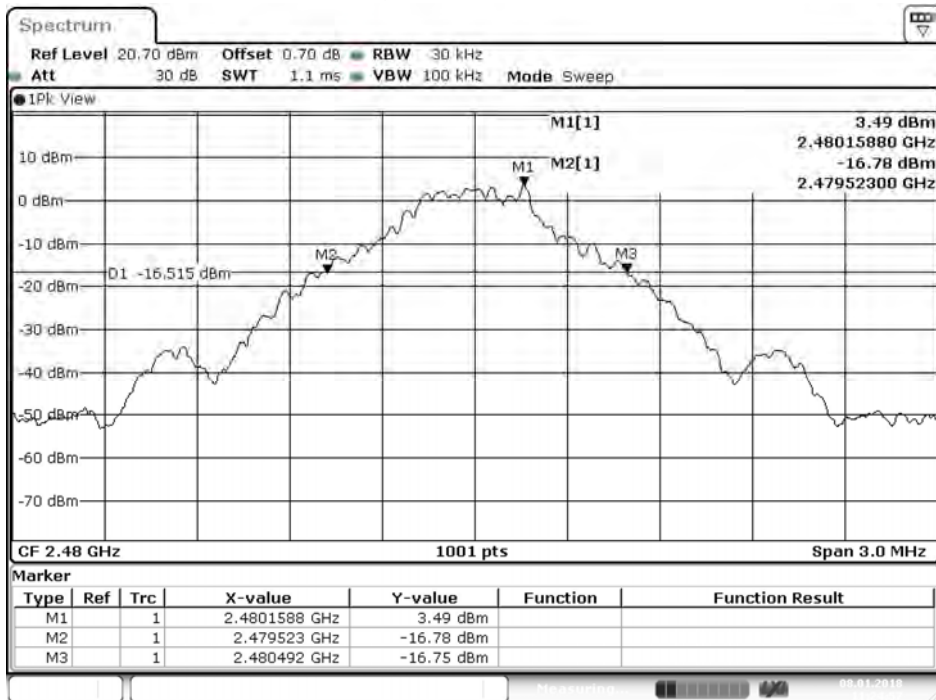

Date: 8.JAN.2018 11:24:57

Product : Tablet PC
 Test Item : Occupied Bandwidth Data
 Test Mode : Mode 2: Transmit - 3Mbps

Channel No.	Frequency (MHz)	Measurement Level (kHz)	Required Limit (kHz)	Result
00	2402	1287	--	NA
39	2441	1293	--	NA
78	2480	1293	--	NA

Figure Channel 00:

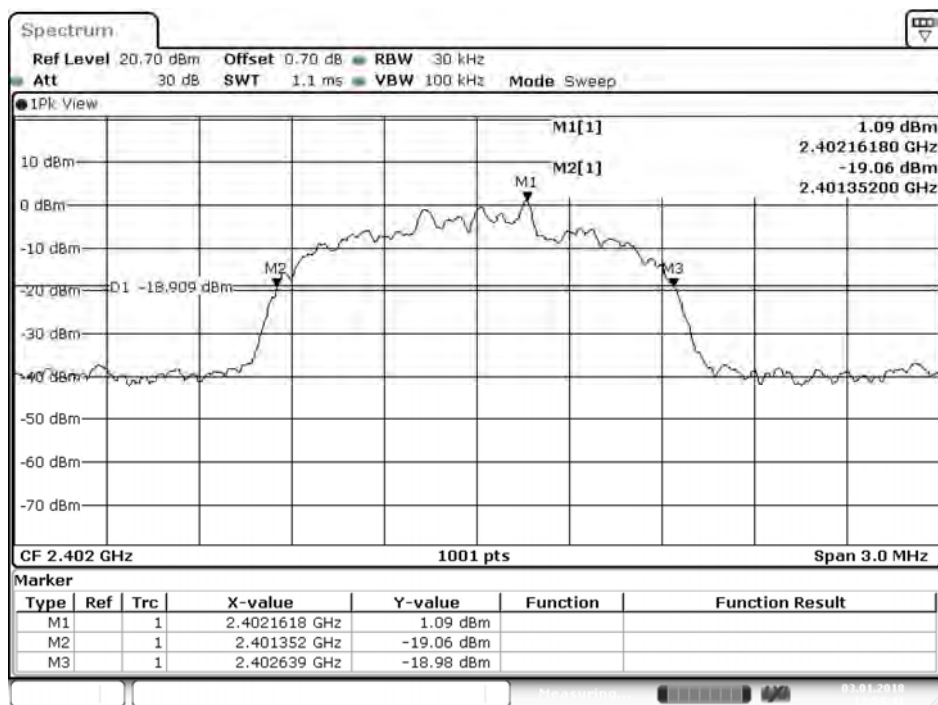

Date: 3.JAN.2018 13:54:42

Figure Channel 39:

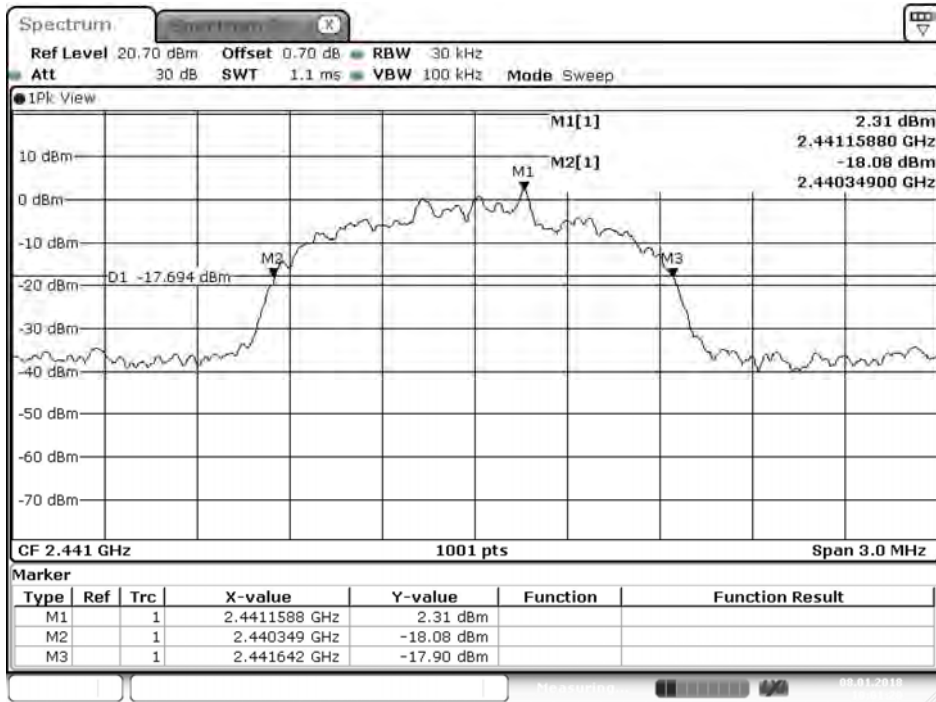

Date: 8.JAN.2018 10:01:20

Figure Channel 78:

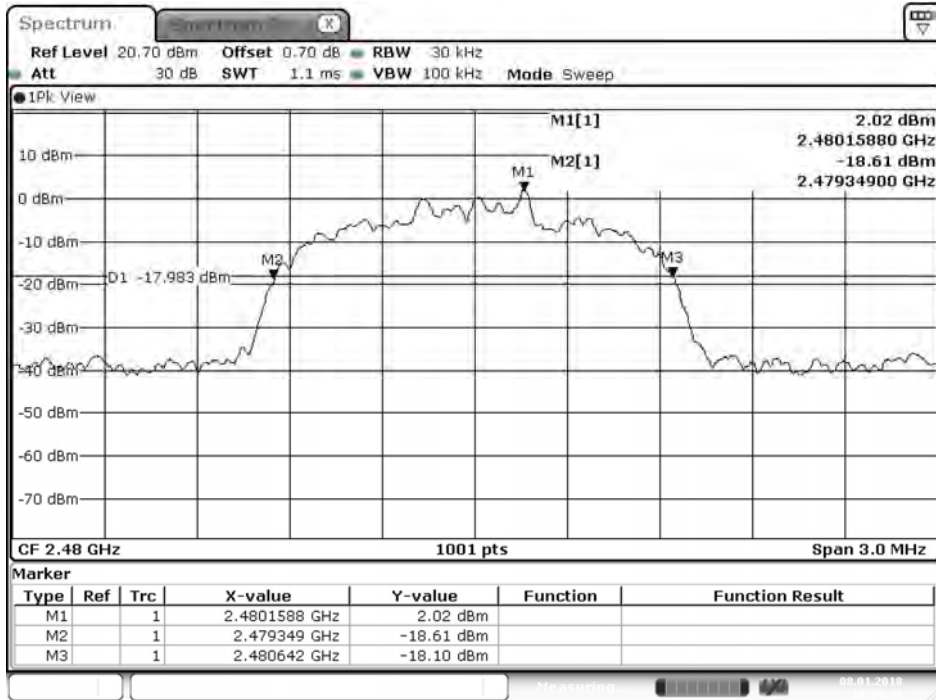

Date: 8.JAN.2018 10:34:50

11. EMI Reduction Method During Compliance Testing

No modification was made during testing.