

FCC Test Report

Product Name	Wireless Motherboard
Model No	TR10CD3
FCC ID	WL6-TRBC41CD1

Applicant	ELITEGROUP COMPUTER SYSTEMS CO., LTD.
Address	No.239, Sec. 2, Ti Ding Blvd., Taipei, Taiwan

Date of Receipt	Mar. 07, 2014
Issued Date	Apr. 11, 2014
Report No.	1430152R-RFUSP49V00
Report Version	V1.0



The test results relate only to the samples tested.

The test results shown in the test report are traceable to the national/international standard through the calibration report of the equipment and evaluated measurement uncertainty herein.

This report must not be used to claim product endorsement by TAF or any agency of the government.

The test report shall not be reproduced without the written approval of QuieTek Corporation.

Test Report

Issued Date: Apr. 11, 2014

Report No.: 1430152R-RFUSP49V00



Product Name	Wireless Motherboard
Applicant	ELITEGROUP COMPUTER SYSTEMS CO., LTD.
Address	No.239, Sec. 2, Ti Ding Blvd., Taipei, Taiwan
Manufacturer	ELITEGROUP COMPUTER SYSTEMS CO., LTD.
Model No.	TR10CD3
FCC ID.	WL6-TRBC41CD1
EUT Rated Voltage	DC 3.7V (Power by Battery)
EUT Test Voltage	AC 120V/60Hz
Trade Name	ECS ELITEGROUP , J.P. SA Couto S.A.
Applicable Standard	FCC CFR Title 47 Part 15 Subpart E: 2012 ANSI C63.10: 2009, FCC KDB-789033
Test Result	Complied

Documented By :

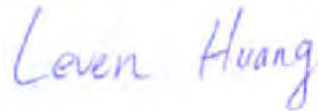

(Senior Adm. Specialist / Leven Huang)

Tested By :



(Engineer / Alan Chen)

Approved By :



(Director / Vincent Lin)

TABLE OF CONTENTS

Description	Page
1. GENERAL INFORMATION.....	5
1.1. EUT Description.....	5
1.2. Operational Description	7
1.3. Tested System Details.....	8
1.4. Configuration of tested System	8
1.5. EUT Exercise Software	8
1.6. Test Facility	9
2. Conducted Emission.....	10
2.1. Test Equipment.....	10
2.2. Test Setup	10
2.3. Limits	11
2.4. Test Procedure	11
2.5. Uncertainty	11
2.6. Test Result of Conducted Emission.....	12
3. Maximun conducted output power.....	18
3.1. Test Equipment.....	18
3.2. Test Setup	18
3.3. Limits	19
3.4. Test Procedur.....	19
3.5. Uncertainty	19
3.6. Test Result of Maximum conducted output power.....	20
4. Peak Power Spectral Density.....	49
4.1. Test Equipment.....	49
4.2. Test Setup	49
4.3. Limits	49
4.4. Test Procedure	50
4.5. Uncertainty	50
4.6. Test Result of Peak Power Spectral Density	51
5. Peak Excursion	77
5.1. Test Equipment.....	77
5.2. Test Setup	77
5.3. Limits	77
5.4. Test Procedure	78
5.5. Uncertainty	78
5.6. Test Result of Peak Excursion.....	79
6. Radiated Emission.....	94
6.1. Test Equipment.....	94
6.2. Test Setup	94
6.3. Limits	95
6.4. Test Procedure	96
6.5. Uncertainty	96
6.6. Test Result of Radiated Emission.....	97
7. Band Edge	143

7.1.	Test Equipment.....	143
7.2.	Test Setup	144
7.3.	Limits	145
7.4.	Test Procedure	145
7.5.	Uncertainty	145
7.6.	Test Result of Band Edge	146
8.	Frequency Stability.....	183
8.1.	Test Equipment.....	183
8.2.	Test Setup	183
8.3.	Limits	183
8.4.	Test Procedure	183
8.5.	Uncertainty	183
8.6.	Test Result of Frequency Stability.....	184
9.	EMI Reduction Method During Compliance Testing	190
Attachment 1:	EUT Test Photographs	
Attachment 2:	EUT Detailed Photographs	

1. GENERAL INFORMATION

1.1. EUT Description

Product Name	Wireless Motherboard
Trade Name	ECS ELITEGROUP , J.P. SA Couto S.A.
FCC ID.	WL6-TRBC41CD1
Model No.	TR10CD3
Frequency Range	802.11a/n-20MHz: 5180-5320MHz, 5500-5700MHz 802.11n-40MHz: 5190-5310, 5510-5670MHz
Number of Channels	802.11a/n-20MHz: 16; 802.11n-40MHz: 7
Data Rate	802.11a: 6-54Mbps, 802.11n: up to 300Mbps
Channel Control	Auto
Type of Modulation	802.11a/n:OFDM, BPSK, QPSK, 16QAM, 64QAM
Antenna type	Chip / PIFA Antenna
Antenna Gain	Refer to the table “Antenna List”

Antenna List

No.	Manufacturer	Part No.	Antenna Type	Peak Gain
1	WGT	13H130-JV1050	PIFA Antenna (Main)	2.36dBi For 5.15~5.35GHz 1.78dBi For 5.47~5.725GHz
	Pulse	02H475-006500	Chip Antenna (Aux)	4.2dBi For 5.15~5.35GHz 4.2dBi For 5.47~5.725GHz
2	JEM	13H130-JV1070	PIFA Antenna (Main)	1.55dBi For 5.15~5.35GHz -0.56dBi For 5.47~5.725GHz
	Pulse	02H475-006500	Chip Antenna (Aux)	4.2dBi For 5.15~5.35GHz 4.2dBi For 5.47~5.725GHz

Note: 1.The antenna of EUT is conform to FCC 15.203

2.Only the higher gain antenna was tested and recorded in this report.

802.11a/n-20MHz Center Working Frequency of Each Channel:

Channel	Frequency	Channel	Frequency	Channel	Frequency	Channel	Frequency
Channel 36:	5180 MHz	Channel 40:	5200 MHz	Channel 44:	5220 MHz	Channel 48:	5240 MHz
Channel 52:	5260 MHz	Channel 56:	5280 MHz	Channel 60:	5300 MHz	Channel 64:	5320 MHz
Channel 100:	5500 MHz	Channel 104:	5520 MHz	Channel 108:	5540 MHz	Channel 112:	5560 MHz
Channel 116:	5580 MHz	Channel 132:	5660 MHz	Channel 136:	5680 MHz	Channel 140:	5700 MHz

802.11n-40MHz Center Working Frequency of Each Channel:

Channel	Frequency	Channel	Frequency	Channel	Frequency	Channel	Frequency
Channel 38:	5190 MHz	Channel 46:	5230 MHz	Channel 54:	5270 MHz	Channel 62:	5310 MHz
Channel 102:	5510 MHz	Channel 110:	5550 MHz	Channel 134:	5670 MHz		

Note:

1. This device is a Wireless Motherboard with a built-in WLAN transceiver.
2. During this report chain A is Chip antenna(Aux), Chain B is PIFA antenna(Main)
3. Regarding to the operation frequency, the lowest, middle and highest frequency are selected to perform the test.
4. Lowest and highest data rates are tested in each mode. Only worst case is shown in the report. (802.11a is 6Mbps, 802.11n-20BW is 14.4Mbps and 802.11n-40BW are 30Mbps)
5. These tests were conducted on a sample of the equipment for the purpose of demonstrating compliance with Part 15 Subpart E for Unlicensed National Information Infrastructure devices.
6. The radiation measurements are performed in X, Y, Z axis positioning. Only the worst case is shown in the report.

Test Mode	Mode 1: Transmit (802.11a-6Mbps) Mode 2: Transmit (802.11n-20BW 14.4Mbps) Mode 3: Transmit (802.11n-40BW 30Mbps)
-----------	--

1.3. Tested System Details

The types for all equipment, plus descriptions of all cables used in the tested system (including inserted cards) are:

Product	Manufacturer	Model No.	Serial No.	Power Cord
1 Notebook PC	DELL	PPT	N/A	Non-Shielded, 0.8m
2 LED Monitor	DELL	ST2402Lb	CN-0X0K27-74261-27E -0M6U T	Non-Shielded, 1.8m
3 Earphone	AIWA	N/A	N/A	N/A
4 Battery	N/A	TR10-1S8100-T1T2	N/A	N/A

Signal Cable Type	Signal cable Description
A USB Cable	Shielded, 1.2m
B HDMI Cable	Shielded, 1.6m
C Earphone Cable	Non-Shielded, 1.2m

1.4. Configuration of tested System

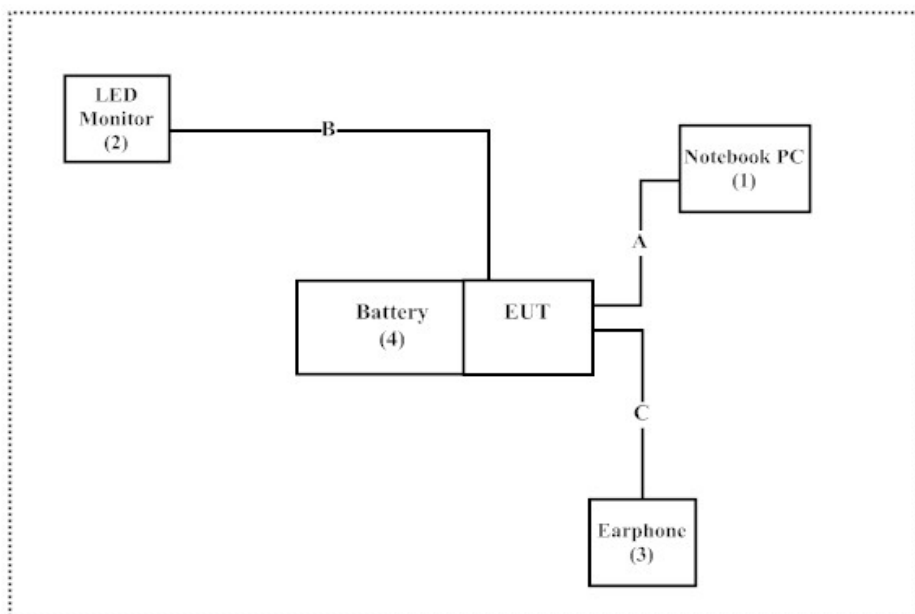

1.5. EUT Exercise Software

- (1) Setup the EUT as shown in Section 1.4
- (2) Execute program “adb.exe” on the Notebook PC.
- (3) Configure the test mode, the test channel, and the data rate.
- (4) Press “OK” to start the continuous Transmit.
- (5) Verify that the EUT works properly.

1.6. Test Facility

Ambient conditions in the laboratory:

Items	Required (IEC 68-1)	Actual
Temperature (°C)	15-35	20-35
Humidity (%RH)	25-75	50-65
Barometric pressure (mbar)	860-1060	950-1000

The related certificate for our laboratories about the test site and management system can be downloaded from Quietek Corporation's Web Site : <http://tw.quietek.com/modules/myalbum/>

The address and introduction of Quietek Corporation's laboratories can be founded in our Web site : <http://www.quietek.com/>

Site Description: File on
 Federal Communications Commission
 FCC Engineering Laboratory
 7435 Oakland Mills Road
 Columbia, MD 21046
 Registration Number: 92195

Site Name: Quietek Corporation
 Site Address: No.5-22, Ruishukeng,
 Linkou Dist. New Taipei City 24451,
 Taiwan, R.O.C.
 TEL: 886-2-8601-3788 / FAX : 886-2-8601-3789
 E-Mail : service@quietek.com

FCC Accreditation Number: TW1014

2. Conducted Emission

2.1. Test Equipment

	Equipment	Manufacturer	Model No. / Serial No.	Last Cal.	Remark
X	Test Receiver	R & S	ESCS 30 / 825442/018	Sep., 2013	
X	Artificial Mains Network	R & S	ENV4200 / 848411/10	Feb., 2014	Peripherals
X	LISN	R & S	ESH3-Z5 / 825562/002	Feb., 2014	EUT
	DC LISN	Schwarzbeck	8226 / 176	Mar, 2014	EUT
X	Pulse Limiter	R & S	ESH3-Z2 / 357.8810.52	Feb., 2014	
	No.1 Shielded Room				

Note:

1. All equipments are calibrated every one year.
2. The test instruments marked by “X” are used to measure the final test results.

2.2. Test Setup

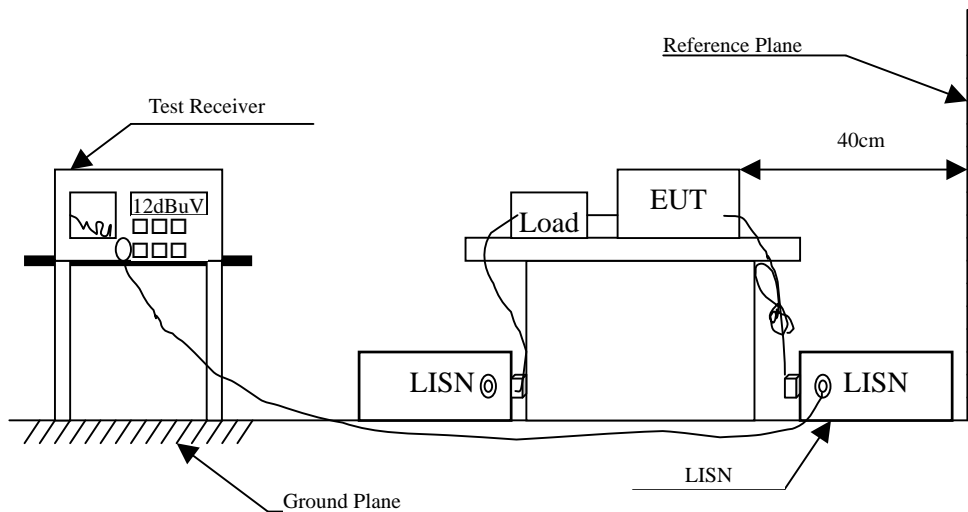

2.3. Limits

FCC Part 15 Subpart C Paragraph 15.207 (dBuV) Limit		
Frequency MHz	Limits	
	QP	AV
0.15 - 0.50	66-56	56-46
0.50-5.0	56	46
5.0 - 30	60	50

Remarks : In the above table, the tighter limit applies at the band edges.

2.4. Test Procedure

The EUT and simulators are connected to the main power through a line impedance stabilization network (L.I.S.N.). This provides a 50 ohm /50uH coupling impedance for the measuring equipment. The peripheral devices are also connected to the main power through a LISN that provides a 50ohm /50uH coupling impedance with 50ohm termination. (Please refers to the block diagram of the test setup and photographs.)

Both sides of A.C. line are checked for maximum conducted interference. In order to find the maximum emission, the relative positions of equipment and all of the interface cables must be changed according to ANSI C63.10:2009 on conducted measurement.

Conducted emissions were invested over the frequency range from 0.15MHz to 30MHz using a receiver bandwidth of 9kHz.

The EUT was setup to ANSI C63.10, 2009; tested to DTS test procedure of FCC KDB-789033 for compliance to FCC 47CFR Subpart E requirements.

2.5. Uncertainty

± 2.26 dB

2.6. Test Result of Conducted Emission

Product : Wireless Motherboard
 Test Item : Conducted Emission Test
 Power Line : Line 1
 Test Mode : Mode 3: Transmit (802.11n-40BW 30Mbps) (5190MHz)

Frequency MHz	Correct Factor dB	Reading Level dBuV	Measurement Level dBuV	Margin dB	Limit dBuV
LINE 1					
Quasi-Peak					
0.158	9.747	34.680	44.427	-21.344	65.771
0.170	9.743	32.900	42.644	-22.785	65.429
0.212	9.739	28.440	38.179	-26.050	64.229
0.341	9.745	26.150	35.895	-24.648	60.543
0.505	9.753	33.100	42.853	-13.147	56.000
0.654	9.759	26.900	36.659	-19.341	56.000
Average					
0.158	9.747	26.160	35.907	-19.864	55.771
0.170	9.743	13.810	23.554	-31.875	55.429
0.212	9.739	20.420	30.159	-24.070	54.229
0.341	9.745	10.480	20.225	-30.318	50.543
0.505	9.753	21.420	31.173	-14.827	46.000
0.654	9.759	19.760	29.519	-16.481	46.000

Note:

1. All Reading Levels are Quasi-Peak and average value.
2. "■" means the worst emission level.
3. Measurement Level = Reading Level + Correct Factor

Product : Wireless Motherboard
 Test Item : Conducted Emission Test
 Power Line : Line 2
 Test Mode : Mode 3: Transmit (802.11n-40BW 30Mbps) (5190MHz)

Frequency MHz	Correct Factor dB	Reading Level dBuV	Measurement Level dBuV	Margin dB	Limit dBuV
LINE2					
Quasi-Peak					
0.166	9.747	33.830	43.577	-21.966	65.543
0.212	9.749	28.580	38.329	-25.900	64.229
0.373	9.747	28.450	38.197	-21.432	59.629
0.498	9.752	32.750	42.502	-13.555	56.057
7.912	9.920	27.580	37.500	-22.500	60.000
21.162	10.105	25.840	35.945	-24.055	60.000
Average					
0.166	9.747	28.500	38.247	-17.296	55.543
0.212	9.749	24.300	34.049	-20.180	54.229
0.373	9.747	15.410	25.157	-24.472	49.629
0.498	9.752	28.740	38.492	-7.565	46.057
7.912	9.920	22.630	32.550	-17.450	50.000
21.162	10.105	20.160	30.265	-19.735	50.000

Note:

1. All Reading Levels are Quasi-Peak and average value.
2. "■" means the worst emission level.
3. Measurement Level = Reading Level + Correct Factor

Product : Wireless Motherboard
 Test Item : Conducted Emission Test
 Power Line : Line 1
 Test Mode : Mode 3: Transmit (802.11n-40BW 30Mbps) (5270MHz)

Frequency MHz	Correct Factor dB	Reading Level dBuV	Measurement Level dBuV	Margin dB	Limit dBuV
LINE 1					
Quasi-Peak					
0.170	9.743	31.770	41.514	-23.915	65.429
0.216	9.739	29.070	38.809	-25.305	64.114
0.377	9.747	28.700	38.447	-21.067	59.514
0.525	9.753	32.540	42.293	-13.707	56.000
1.263	9.795	25.850	35.645	-20.355	56.000
21.170	10.065	26.590	36.655	-23.345	60.000
Average					
0.170	9.743	19.210	28.954	-26.475	55.429
0.216	9.739	21.590	31.329	-22.785	54.114
0.377	9.747	24.340	34.087	-15.427	49.514
0.525	9.753	24.320	34.073	-11.927	46.000
1.263	9.795	17.130	26.925	-19.075	46.000
21.170	10.065	19.700	29.765	-20.235	50.000

Note:

1. All Reading Levels are Quasi-Peak and average value.
2. "■" means the worst emission level.
3. Measurement Level = Reading Level + Correct Factor

Product : Wireless Motherboard
 Test Item : Conducted Emission Test
 Power Line : Line 2
 Test Mode : Mode 3: Transmit (802.11n-40BW 30Mbps) (5270MHz)

Frequency MHz	Correct Factor dB	Reading Level dBuV	Measurement Level dBuV	Margin dB	Limit dBuV
LINE2					
Quasi-Peak					
0.162	9.747	34.780	44.527	-21.130	65.657
0.314	9.744	26.650	36.394	-24.920	61.314
0.377	9.747	28.840	38.587	-20.927	59.514
0.529	9.754	32.420	42.174	-13.826	56.000
7.931	9.920	27.330	37.250	-22.750	60.000
21.205	10.105	25.610	35.715	-24.285	60.000
Average					
0.162	9.747	20.840	30.587	-25.070	55.657
0.314	9.744	20.460	30.204	-21.110	51.314
0.377	9.747	18.490	28.237	-21.277	49.514
0.529	9.754	24.910	34.664	-11.336	46.000
7.931	9.920	21.940	31.860	-18.140	50.000
21.205	10.105	20.650	30.755	-19.245	50.000

Note:

1. All Reading Levels are Quasi-Peak and average value.
2. "■" means the worst emission level.
3. Measurement Level = Reading Level + Correct Factor

Product : Wireless Motherboard
 Test Item : Conducted Emission Test
 Power Line : Line 1
 Test Mode : Mode 3: Transmit (802.11n-40BW 30Mbps) (5550MHz)

Frequency MHz	Correct Factor dB	Reading Level dBuV	Measurement Level dBuV	Margin dB	Limit dBuV
LINE 1					
Quasi-Peak					
0.154	9.749	33.630	43.378	-22.508	65.886
0.205	9.739	27.460	37.199	-27.230	64.429
0.267	9.742	25.920	35.662	-26.995	62.657
0.490	9.752	32.790	42.542	-13.744	56.286
8.056	9.910	27.490	37.400	-22.600	60.000
21.369	10.068	27.010	37.078	-22.922	60.000
Average					
0.154	9.749	19.990	29.738	-26.148	55.886
0.205	9.739	15.970	25.709	-28.720	54.429
0.267	9.742	20.280	30.022	-22.635	52.657
0.490	9.752	27.340	37.092	-9.194	46.286
8.056	9.910	22.110	32.020	-17.980	50.000
21.369	10.068	20.660	30.728	-19.272	50.000

Note:

1. All Reading Levels are Quasi-Peak and average value.
2. "■" means the worst emission level.
3. Measurement Level = Reading Level + Correct Factor

Product : Wireless Motherboard
 Test Item : Conducted Emission Test
 Power Line : Line 2
 Test Mode : Mode 3: Transmit (802.11n-40BW 30Mbps) (5550MHz)

Frequency MHz	Correct Factor dB	Reading Level dBuV	Measurement Level dBuV	Margin dB	Limit dBuV
LINE2					
Quasi-Peak					
0.220	9.750	28.520	38.270	-25.730	64.000
0.267	9.752	25.860	35.612	-27.045	62.657
0.509	9.753	33.100	42.853	-13.147	56.000
1.283	9.798	26.680	36.478	-19.522	56.000
8.021	9.920	27.580	37.500	-22.500	60.000
20.986	10.101	26.380	36.481	-23.519	60.000
Average					
0.220	9.750	20.710	30.460	-23.540	54.000
0.267	9.752	18.890	28.642	-24.015	52.657
0.509	9.753	21.730	31.483	-14.517	46.000
1.283	9.798	17.030	26.828	-19.172	46.000
8.021	9.920	22.510	32.430	-17.570	50.000
20.986	10.101	23.120	33.221	-16.779	50.000

Note:

1. All Reading Levels are Quasi-Peak and average value.
2. "■" means the worst emission level.
3. Measurement Level = Reading Level + Correct Factor

3. Maximun conducted output power

3.1. Test Equipment

	Equipment	Manufacturer	Model No./Serial No.	Last Cal.
X	Power Meter	Anritsu	ML2495A/6K00003357	May, 2013
X	Power Sensor	Anritsu	MA2411B/0738448	Jun, 2013
X	Spectrum Analyzer	Agilent	N9010A / MY48030495	Apr., 2014

Note:

1. All equipments are calibrated with traceable calibrations. Each calibration is traceable to the national or international standards.
2. The test instruments marked with “X” are used to measure the final test results.

3.2. Test Setup

26dBc Occupied Bandwidth

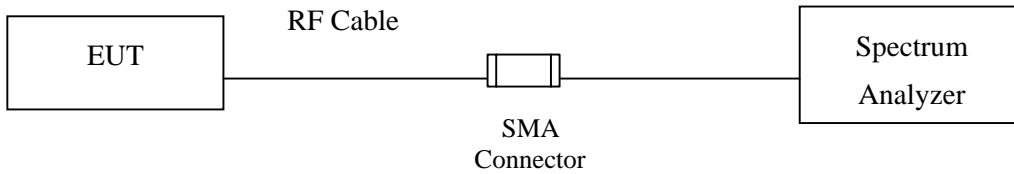

Conduction Power Measurement

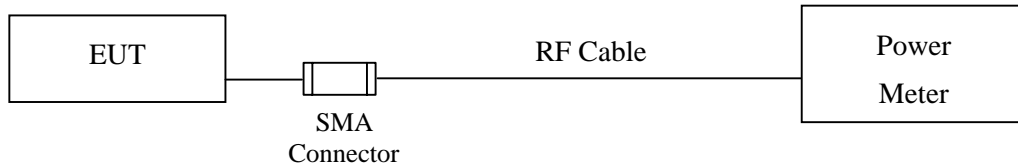

3.3. Limits

- (1) For the band 5.15-5.25 GHz, the maximum conducted output power over the frequency band of operation shall not exceed the lesser of 50 mW or $4 \text{ dBm} + 10\log B$, where B is the 26-dB emission bandwidth in MHz. If transmitting antenna of directional gain greater than 6 dBi are used, the peak transmit power shall be reduced by the amount in dB that directional gain of the antenna exceeds 6 dBi.
- (2) For the band 5.25-5.35 GHz, the maximum conducted output power over the frequency band of operation shall not exceed the lesser of 250 mW or $11 \text{ dBm} + 10\log B$, where B is the 26-dB emission bandwidth in MHz. If transmitting antenna of directional gain greater than 6 dBi are used, the peak transmit power shall be reduced by the amount in dB that directional gain of the antenna exceeds 6 dBi.
- (3) For the band 5.725-5.825 GHz, the maximum conducted output power over the frequency band of operation shall not exceed the lesser of 1W or $17 \text{ dBm} + 10\log B$, where B is the 26-dB emission bandwidth in MHz. If transmitting antenna of directional gain greater than 6 dBi are used, the peak transmit power shall be reduced by the amount in dB that directional gain of the antenna exceeds 6 dBi.

3.4. Test Procedur

As an alternative to FCC KDB-789033, the EUT maximum conducted output power was measured with an average power meter employing a video bandwidth greater than 6dB BW of the emission under test. Maximum conducted output power was read directly from the meter across all data rates, and across three channels within each sub-band. Special care was used to make sure that the EUT was transmitting in continuous mode. This method exceeds the limitations of FCC KDB-789033, and provides more accurate measurements.

The Maximum conducted output power using KDB 789033 section E)3)b) Method PM-G (Measurement using a gated RF average power meter).

3.5. Uncertainty

$\pm 1.27 \text{ dB}$

3.6. Test Result of Maximum conducted output power

Product : Wireless Motherboard
 Test Item : Maximum conducted output power
 Test Site : No.3 OATS
 Test Mode : Mode 1: Transmit (802.11a-6Mbps)

CHAIN A

Cable loss=1dB		Maximum conducted output power								
Channel No.	Frequency (MHz)	Data Rate (Mbps)								Required Limit
		6	9	12	18	24	36	48	54	
		Measurement Level (dBm)								
36	5180	13.16	--	--	--	--	--	--	--	<17dBm
44	5220	13.26	13.22	13.18	13.14	13.1	13.06	13.02	12.98	<17dBm
48	5240	13.32	--	--	--	--	--	--	--	<17dBm
52	5260	13.42	--	--	--	--	--	--	--	<24dBm
60	5300	13.45	13.41	13.37	13.33	13.29	13.25	13.21	13.17	<24dBm
64	5320	13.5	--	--	--	--	--	--	--	<24dBm
100	5500	13.48	--	--	--	--	--	--	--	<24dBm
116	5580	13.48	13.44	13.4	13.36	13.32	13.28	13.24	13.2	<24dBm
140	5700	12.92	--	--	--	--	--	--	--	<24dBm

Note: Maximum conducted output power Value =Reading value on average power meter + cable loss

CHAIN B

Cable loss=1dB		Maximum conducted output power								
Channel No.	Frequency (MHz)	Data Rate (Mbps)								Required Limit
		6	9	12	18	24	36	48	54	
		Measurement Level (dBm)								
36	5180	13.12	--	--	--	--	--	--	--	<17dBm
44	5220	13.06	13	12.94	12.88	12.82	12.76	12.7	12.64	<17dBm
48	5240	12.93	--	--	--	--	--	--	--	<17dBm
52	5260	12.73	--	--	--	--	--	--	--	<24dBm
60	5300	13.45	13.39	13.33	13.27	13.21	13.15	13.09	13.03	<24dBm
64	5320	13.27	--	--	--	--	--	--	--	<24dBm
100	5500	13.09	--	--	--	--	--	--	--	<24dBm
116	5580	13.48	13.42	13.36	13.3	13.24	13.18	13.12	13.06	<24dBm
140	5700	12.79	--	--	--	--	--	--	--	<24dBm

Note: Maximum conducted output power Value =Reading value on average power meter + cable loss

Maximum conducted output power Measurement:
CHAIN A

Channel No	Frequency Range (MHz)	26dB Bandwidth (MHz)	Output Power (dBm)	Output Power Limit	
				(dBm)	dBm+10log(BW)
36	5180	19.550	13.16	17	16.91
44	5220	19.500	13.26	17	16.90
48	5240	20.250	13.32	17	17.06
52	5260	21.400	13.42	24	24.30
60	5300	19.500	13.45	24	23.90
64	5320	23.250	13.50	24	24.66
100	5500	22.100	13.48	24	24.44
116	5580	24.200	13.48	24	24.84
140	5700	28.550	12.92	24	25.56

Note:

1. Power Output Value = Reading value on average power meter + cable loss

26dBc Occupied Bandwidth: Channel 36:

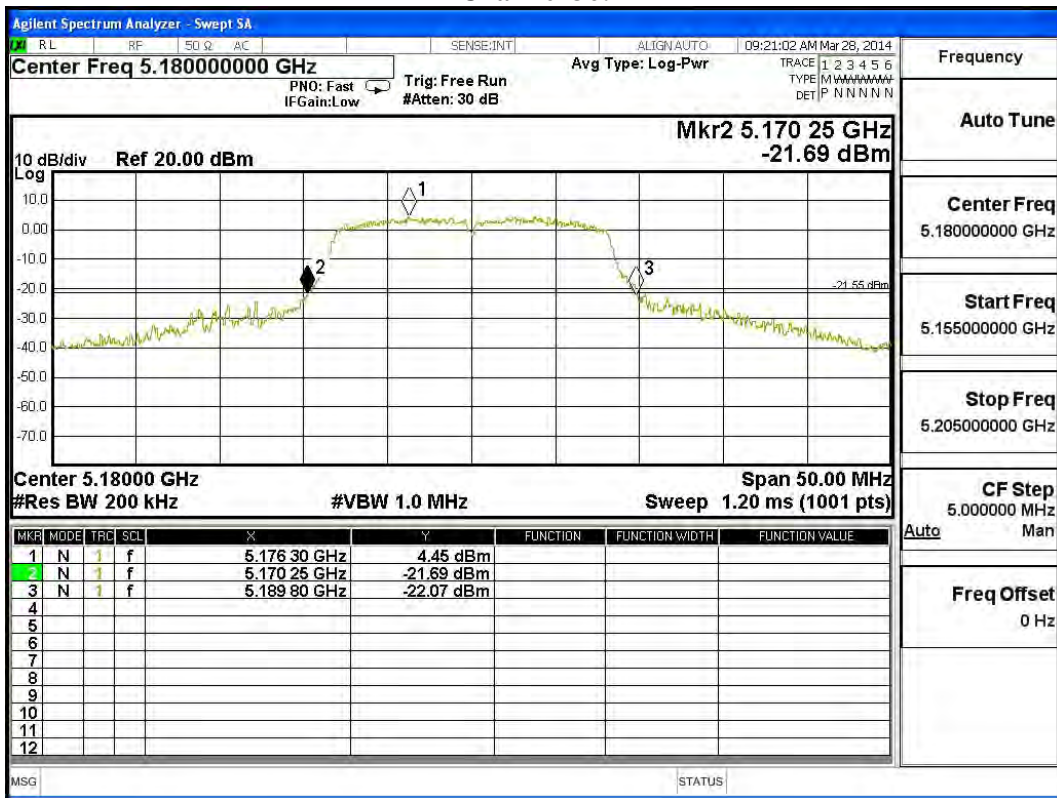

Channel 44:

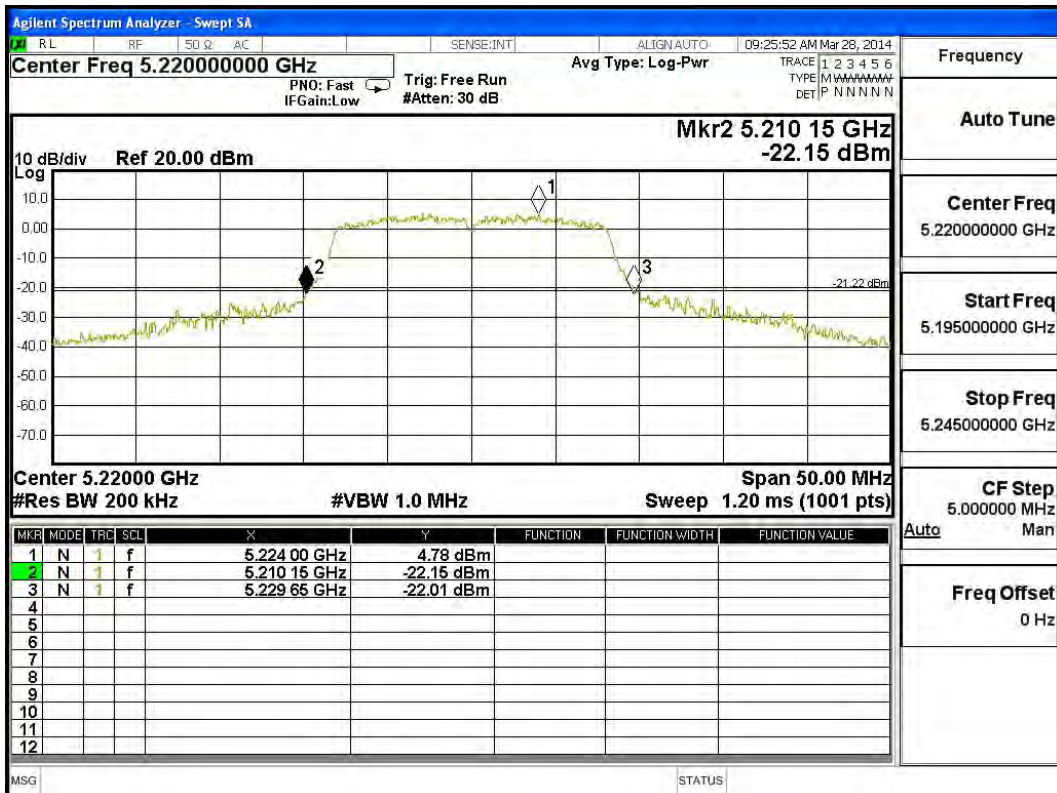

Channel 48:

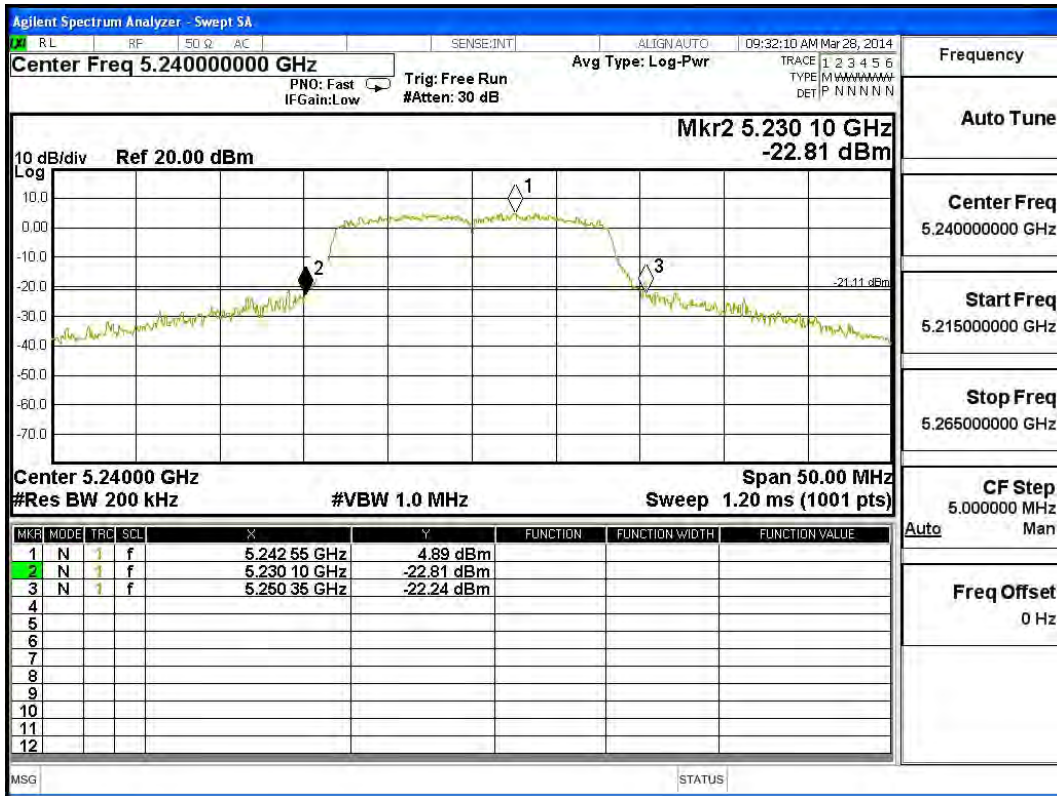

Channel 52:

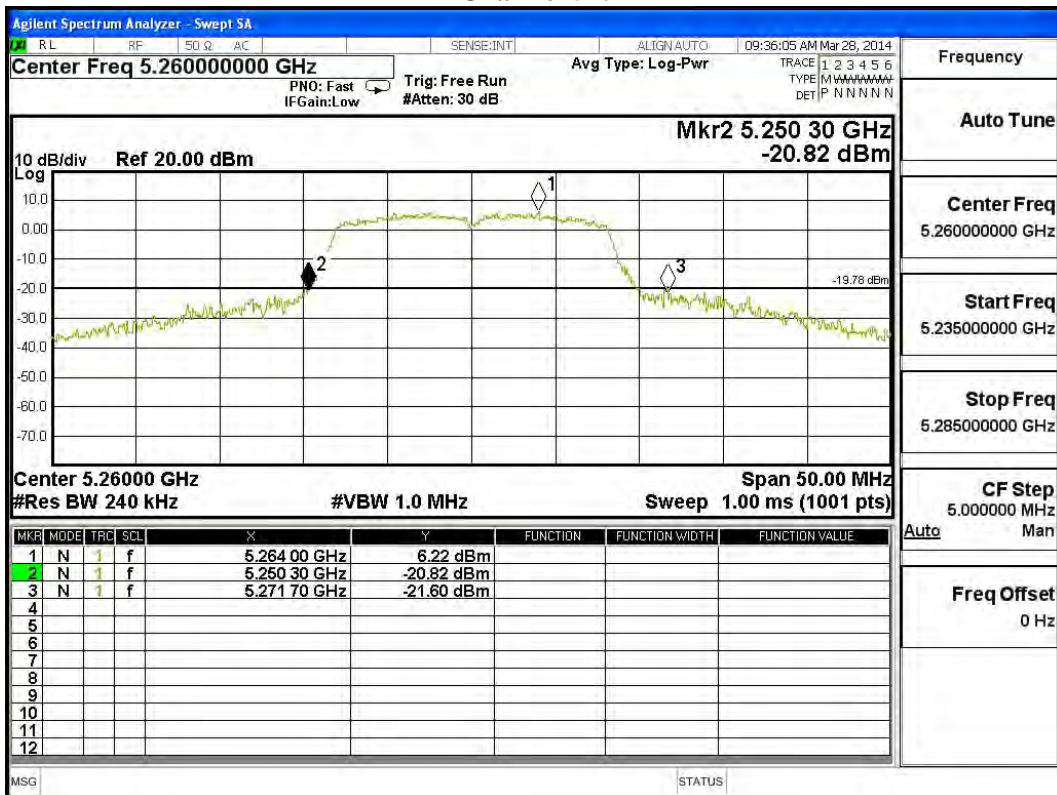

Channel 60:

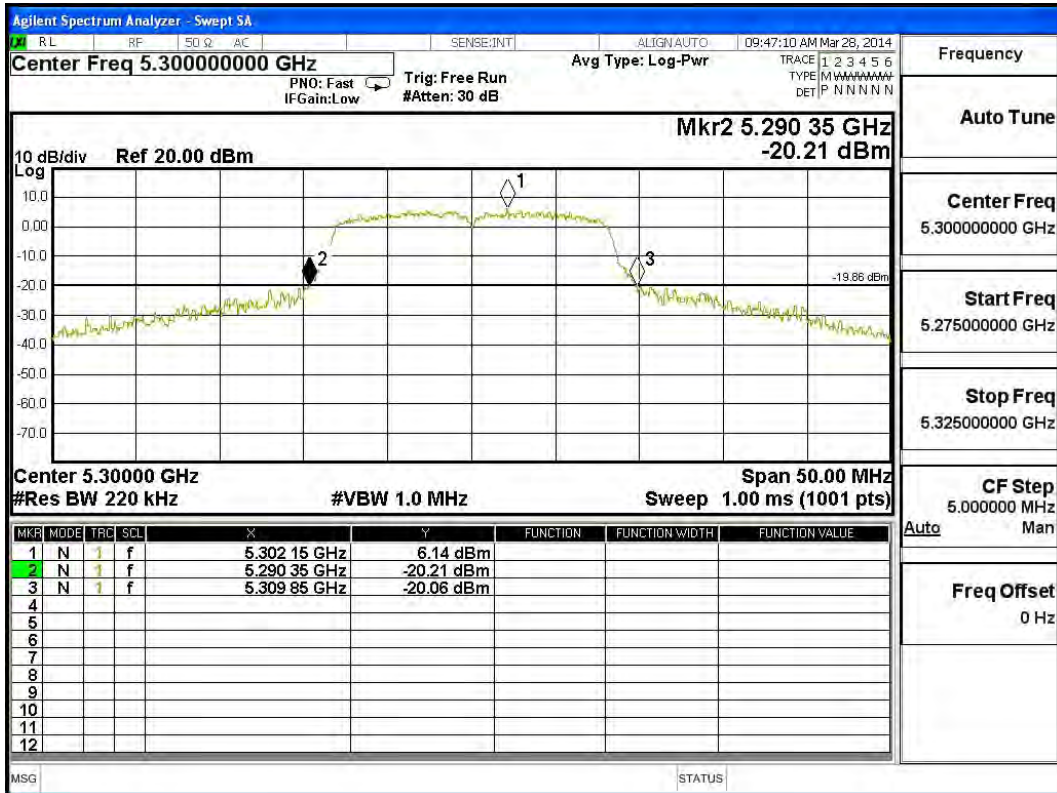

Channel 64:

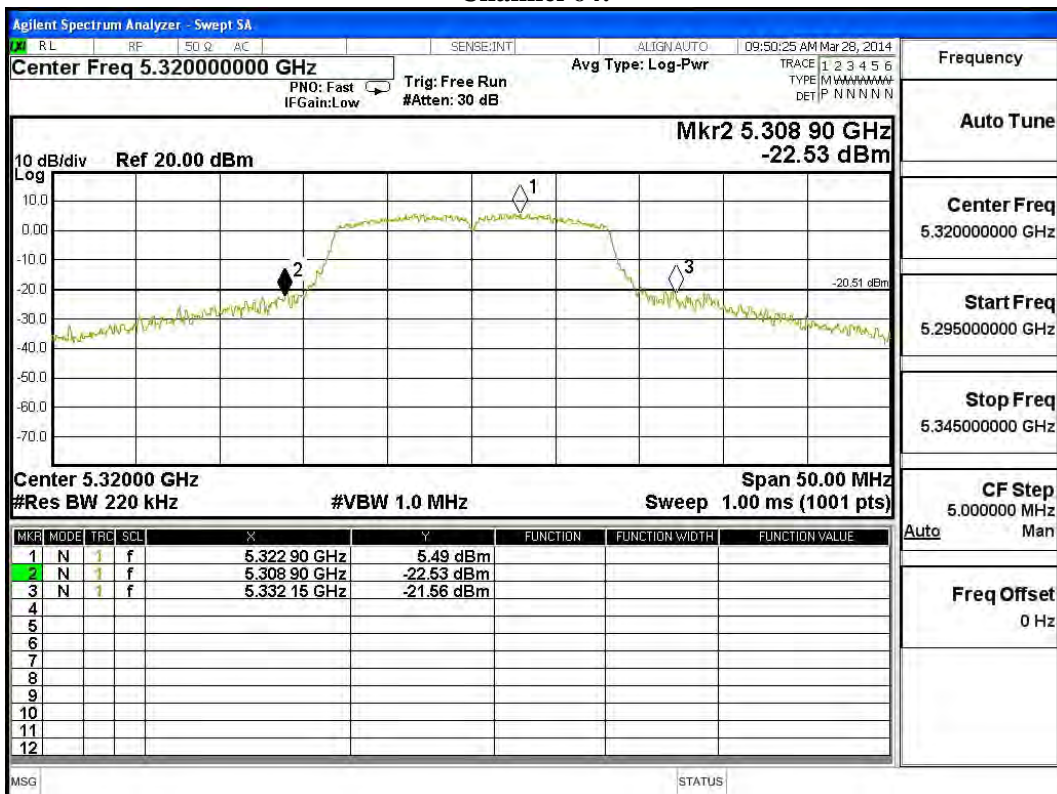

Channel 100:

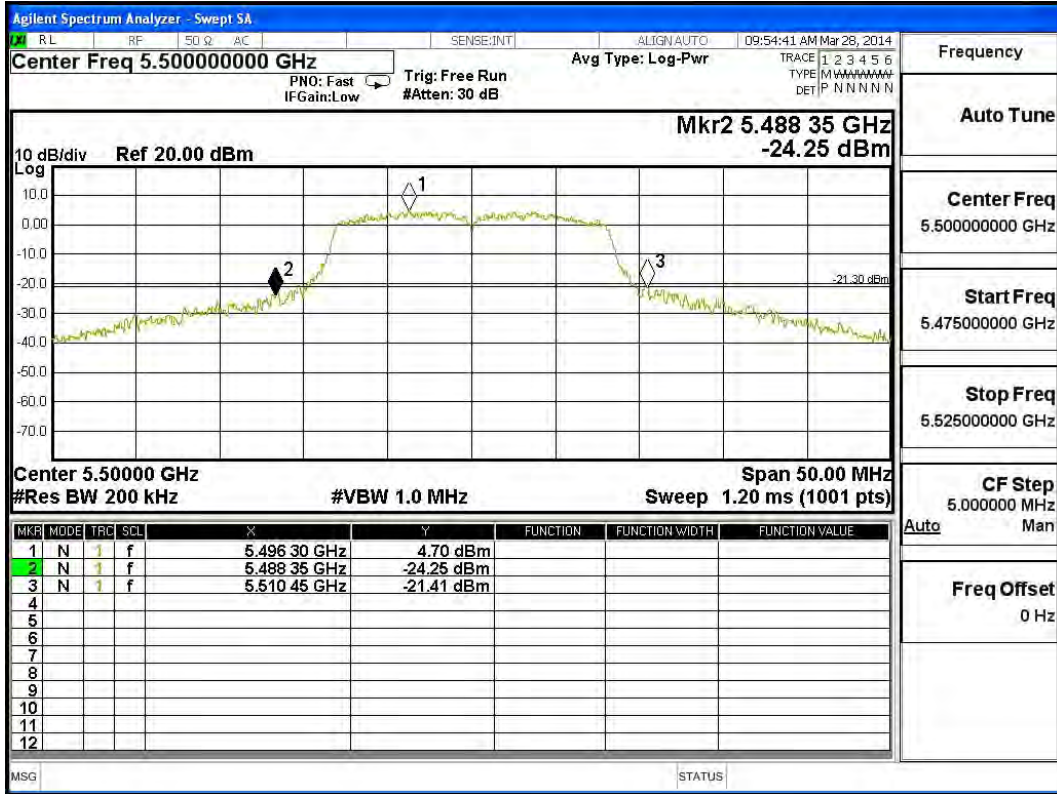

Channel 116:

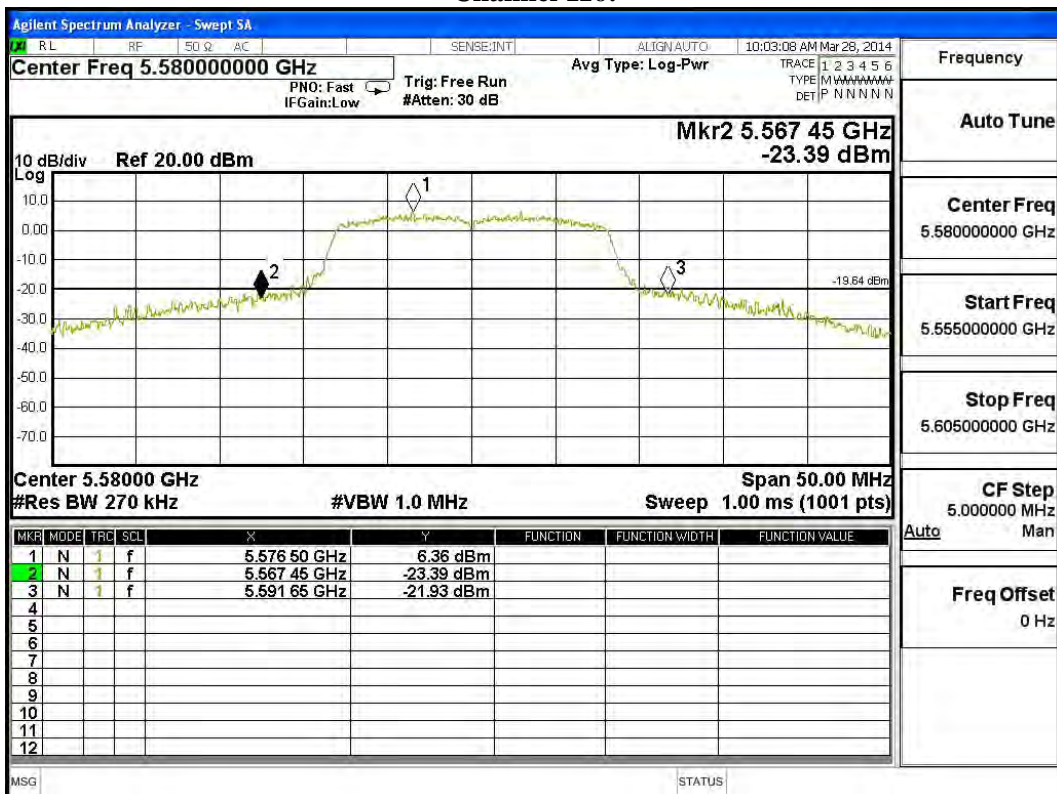

Channel 140:

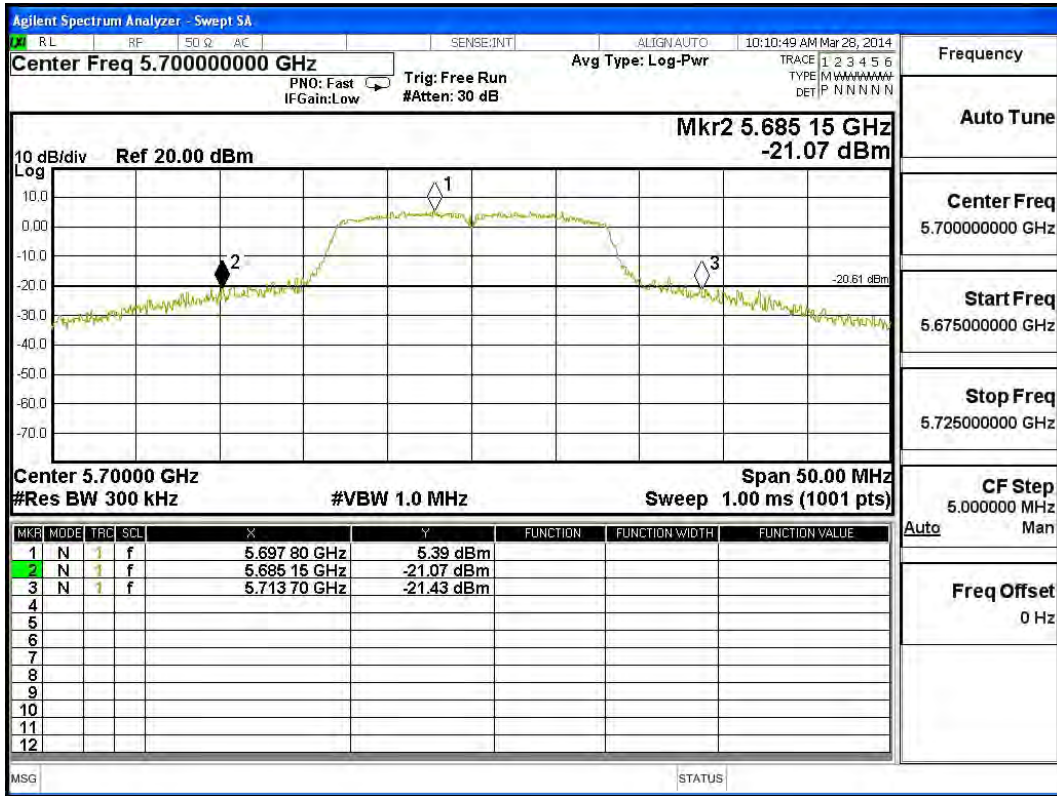

Product : Wireless Motherboard
 Test Item : Maximum conducted output power
 Test Site : No.3 OATS
 Test Mode : Mode 2: Transmit (802.11n-20BW 14.4Mbps)

CHAIN A

Cable loss=1dB		Maximum conducted output power								
Channel No.	Frequency (MHz)	Data Rate (Mbps)								Required Limit
		14.4	28.9	43.3	57.8	86.7	115.6	130	144.4	
		Measurement Level (dBm)								
36	5180	13.11	--	--	--	--	--	--	--	<17dBm
44	5220	13.13	13.06	12.99	12.92	12.85	12.78	12.71	12.64	<17dBm
48	5240	13.16	--	--	--	--	--	--	--	<17dBm
52	5260	13.26	--	--	--	--	--	--	--	<24dBm
60	5300	13.45	13.39	13.33	13.27	13.21	13.15	13.09	13.03	<24dBm
64	5320	13.47	--	--	--	--	--	--	--	<24dBm
100	5500	13.35	--	--	--	--	--	--	--	<24dBm
116	5580	12.96	12.9	12.84	12.78	12.72	12.66	12.6	12.54	<24dBm
140	5700	12.6	--	--	--	--	--	--	--	<24dBm

Note: Maximum conducted output power Value =Reading value on average power meter + cable loss

CHAIN B

Cable loss=1dB		Maximum conducted output power								
Channel No.	Frequency (MHz)	Data Rate (Mbps)								Required Limit
		14.4	28.9	43.3	57.8	86.7	115.6	130	144.4	
		Measurement Level (dBm)								
36	5180	12.74	--	--	--	--	--	--	--	<17dBm
44	5220	12.73	12.69	12.65	12.61	12.57	12.53	12.49	12.45	<17dBm
48	5240	12.58	--	--	--	--	--	--	--	<17dBm
52	5260	12.49	--	--	--	--	--	--	--	<24dBm
60	5300	12.23	12.19	12.15	12.11	12.07	12.03	11.99	11.95	<24dBm
64	5320	12.35	--	--	--	--	--	--	--	<24dBm
100	5500	12.49	--	--	--	--	--	--	--	<24dBm
116	5580	12.89	12.77	12.65	12.53	12.41	12.29	12.17	12.05	<24dBm
140	5700	13.26	--	--	--	--	--	--	--	<24dBm

Note: Maximum conducted output power Value =Reading value on average power meter + cable loss

Maximum conducted output power Measurement:
(CHAIN A+ B)

Channel Number	Frequency (MHz)	26dB Bandwidth (MHz)	Chain A Power (dBm)	Chain B Power (dBm)	Output Power (dBm)	Output Power Limit	
						(dBm)	dBm+10log(BW)
36	5180	20.050	13.11	12.74	15.94	17	17.02
44	5220	19.750	13.13	12.73	15.94	17	16.96
48	5240	19.900	13.16	12.58	15.89	17	16.99
52	5260	20.050	13.26	12.49	15.90	24	24.02
60	5300	21.950	13.45	12.23	15.89	24	24.41
64	5320	21.550	13.47	12.35	15.96	24	24.33
100	5500	25.850	13.35	12.49	15.95	24	25.12
116	5580	24.450	12.96	12.89	15.94	24	24.88
140	5700	25.950	12.60	13.26	15.95	24	25.14

Note:

1. Power Output Value = Reading value on average power meter + cable loss
2. Output Power (dBm) = 10LOG (Chain A Power (mW)+ Chain B Power (mW))
3. 26 dB Bandwidth is the bandwidth of chain A or chain B whichever is less bandwidth, output power limitation is more stringent.

26dBc Occupied Bandwidth: Channel 36 -Chain A

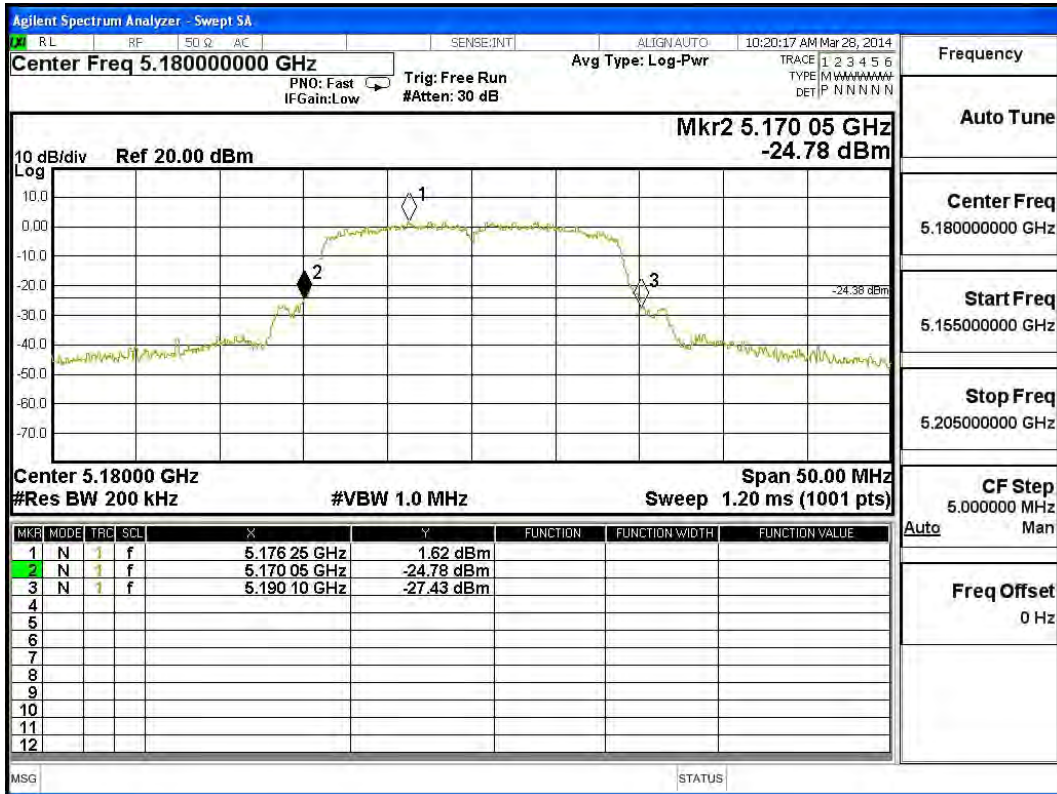

Channel 44 -Chain A

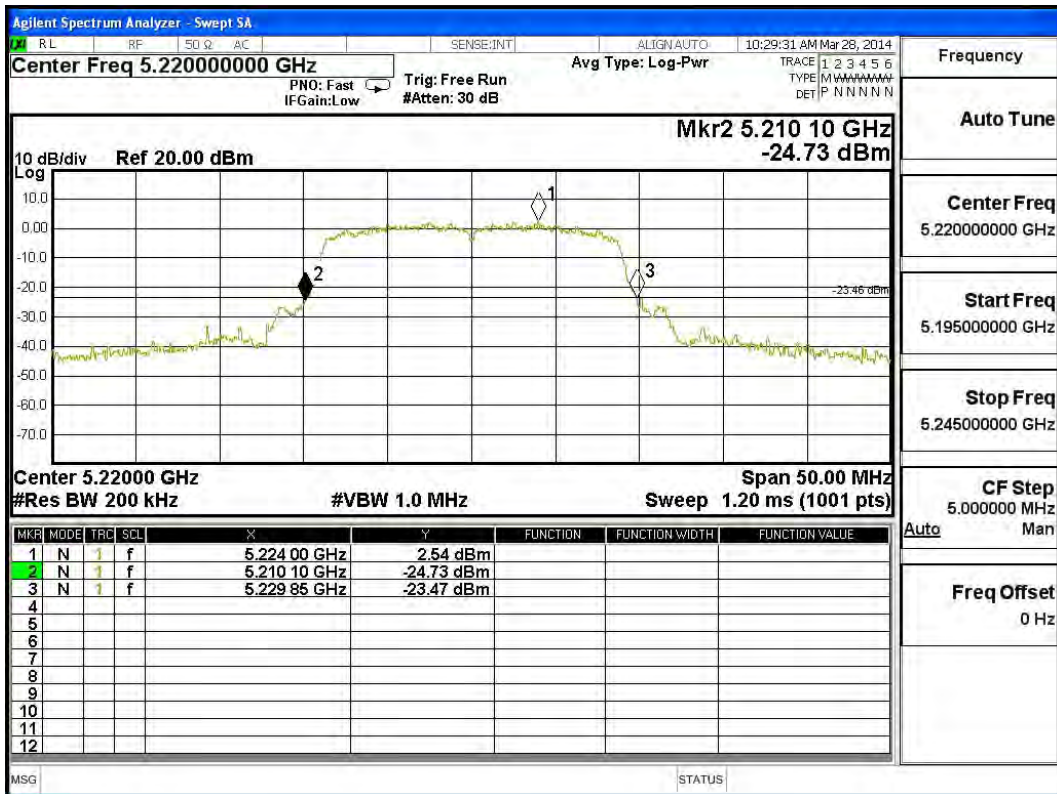

Channel 48 -Chain A

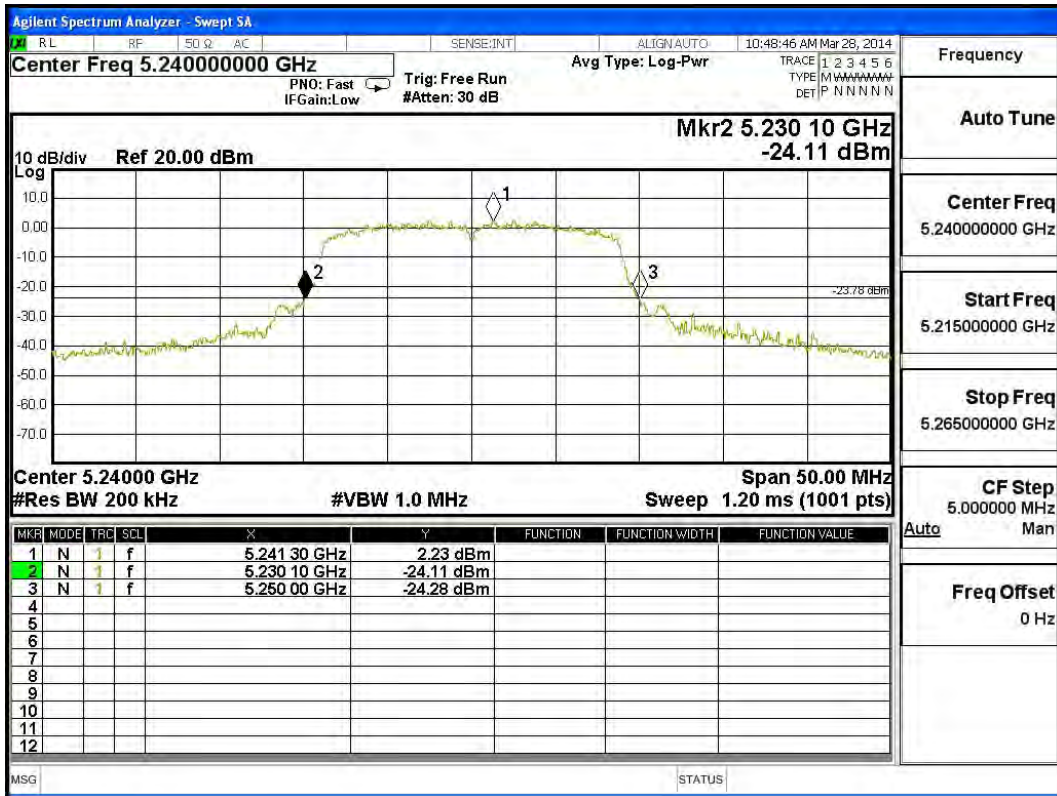

Channel 52 -Chain A

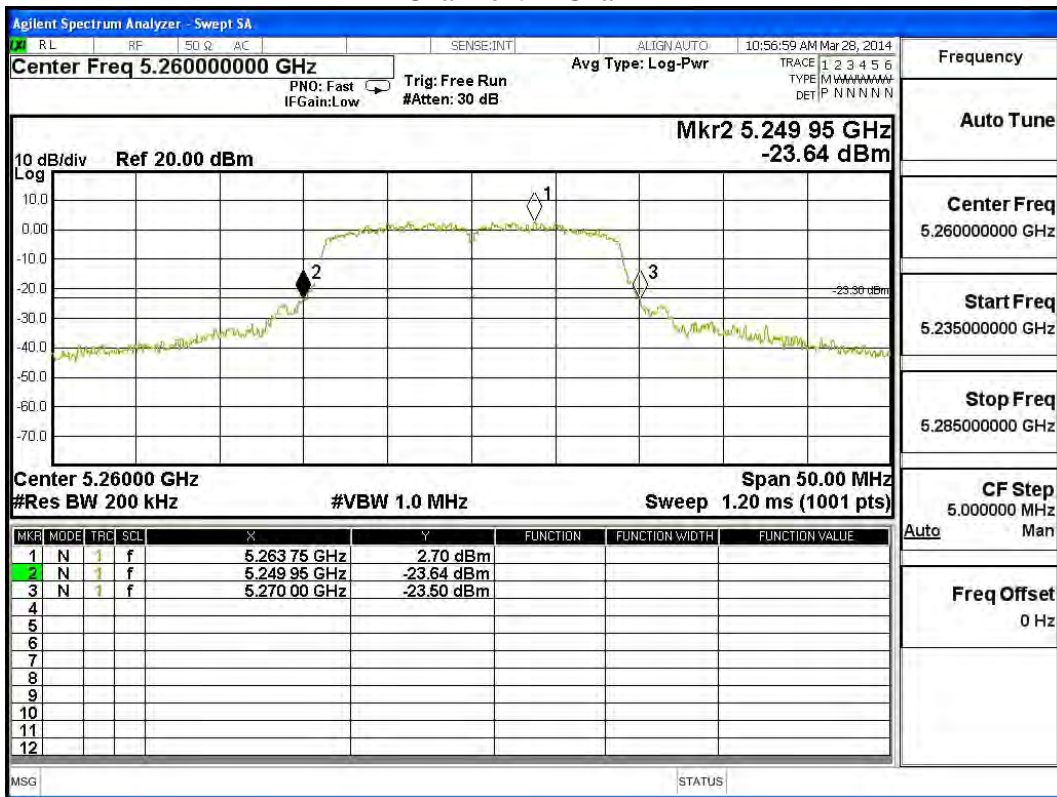

Channel 60 -Chain A

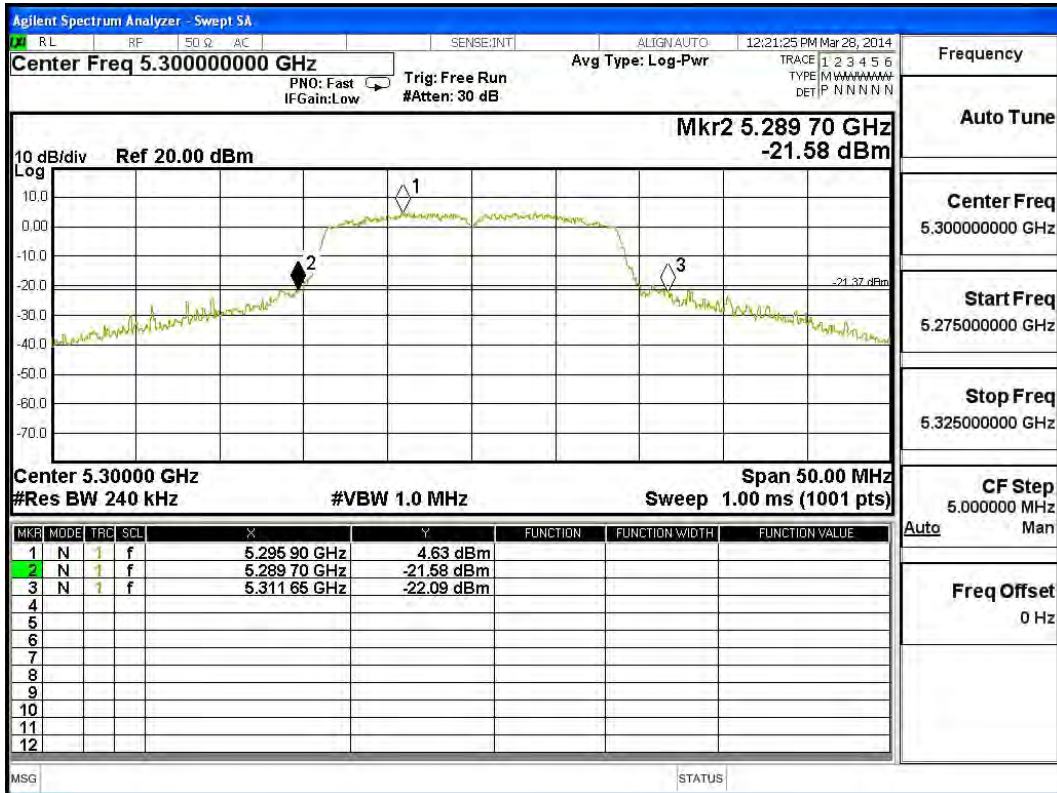

Channel 64 -Chain A

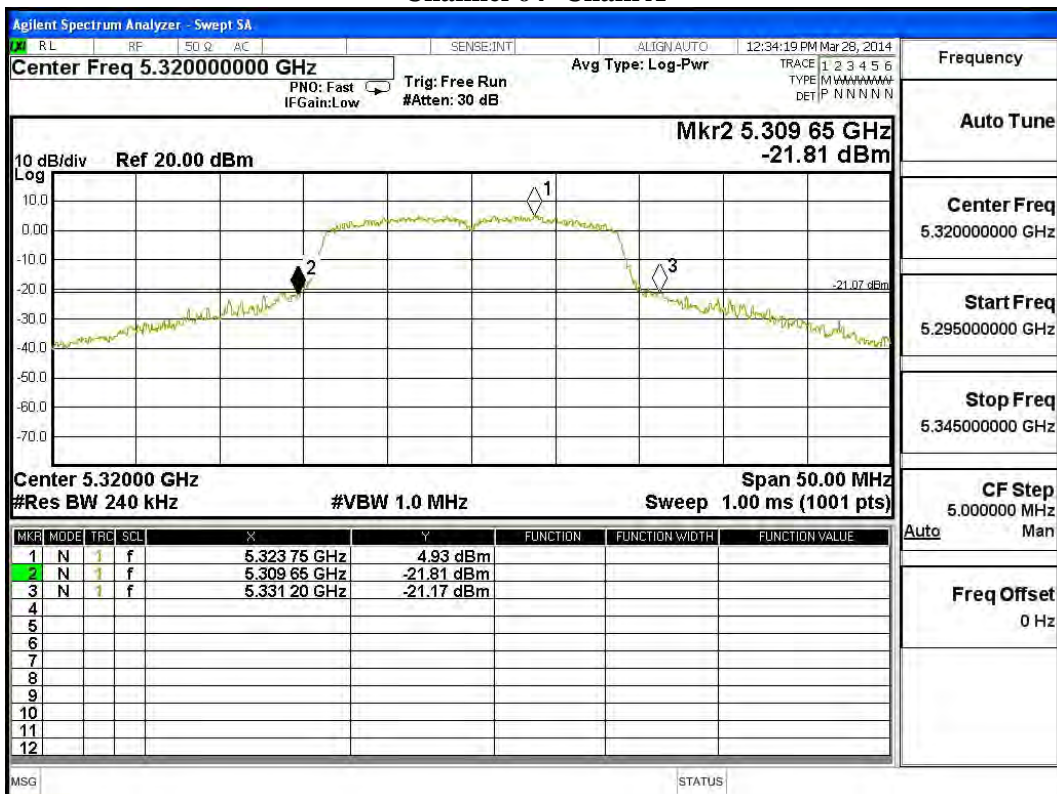

Channel 100 -Chain A

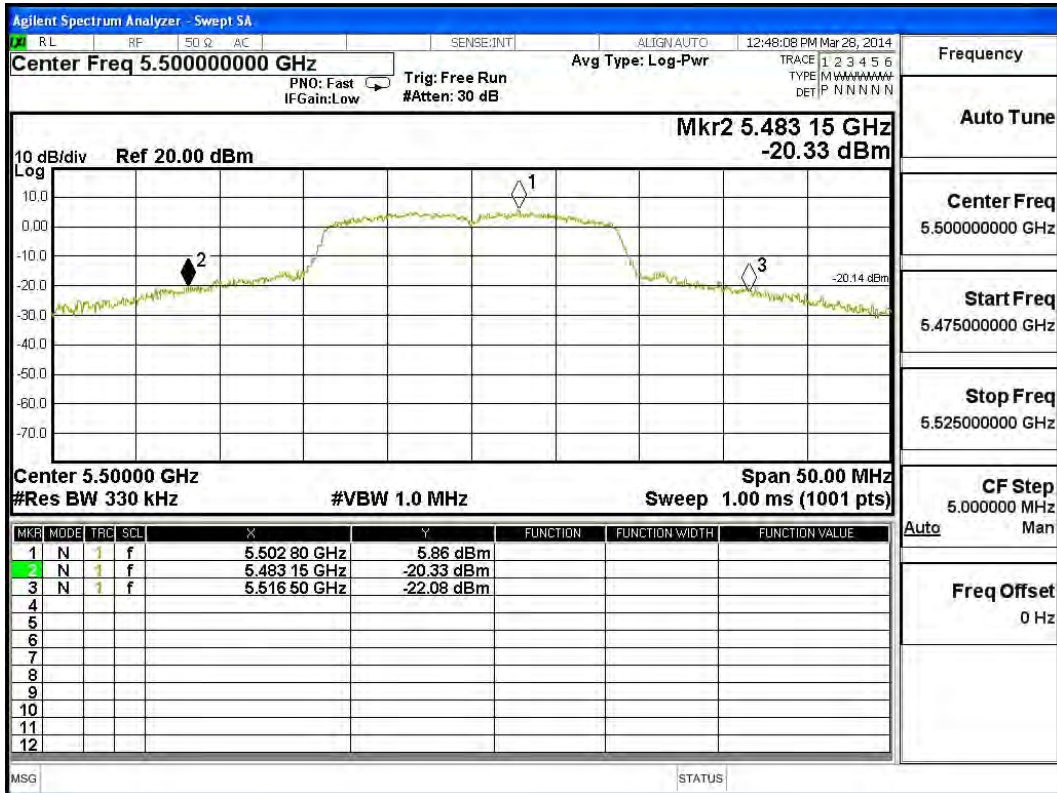

Channel 116 -Chain A

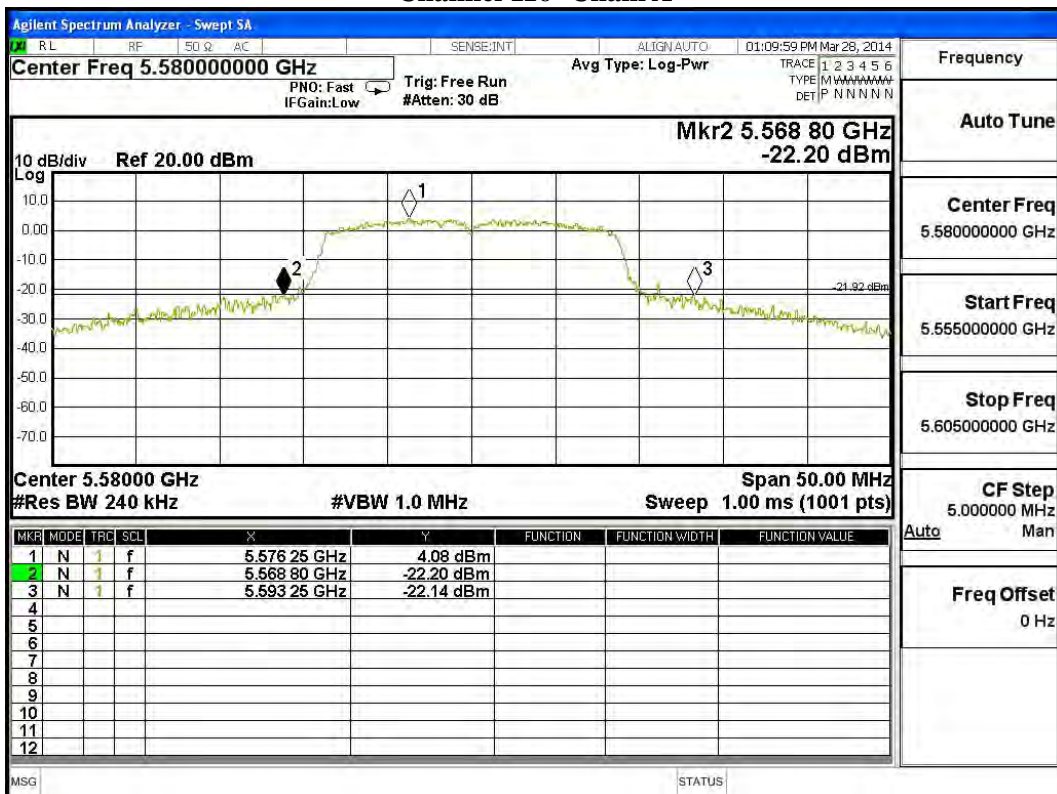

Channel 140 -Chain A

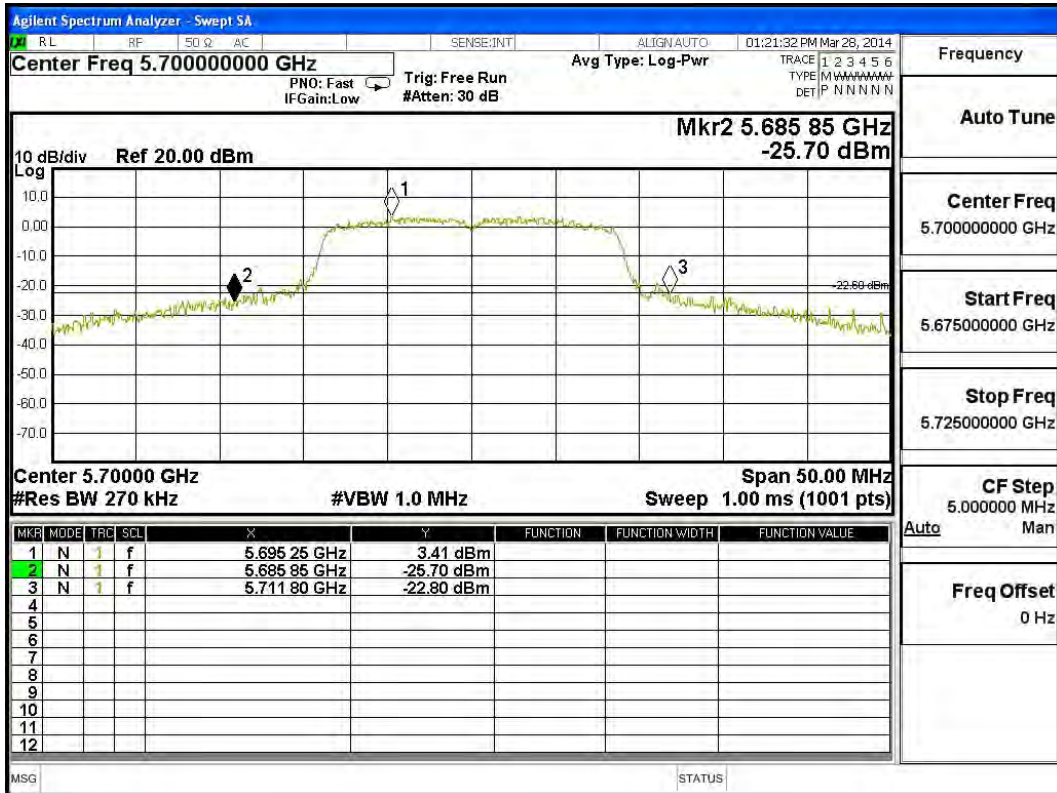

26dBc Occupied Bandwidth: Channel 36 -Chain B

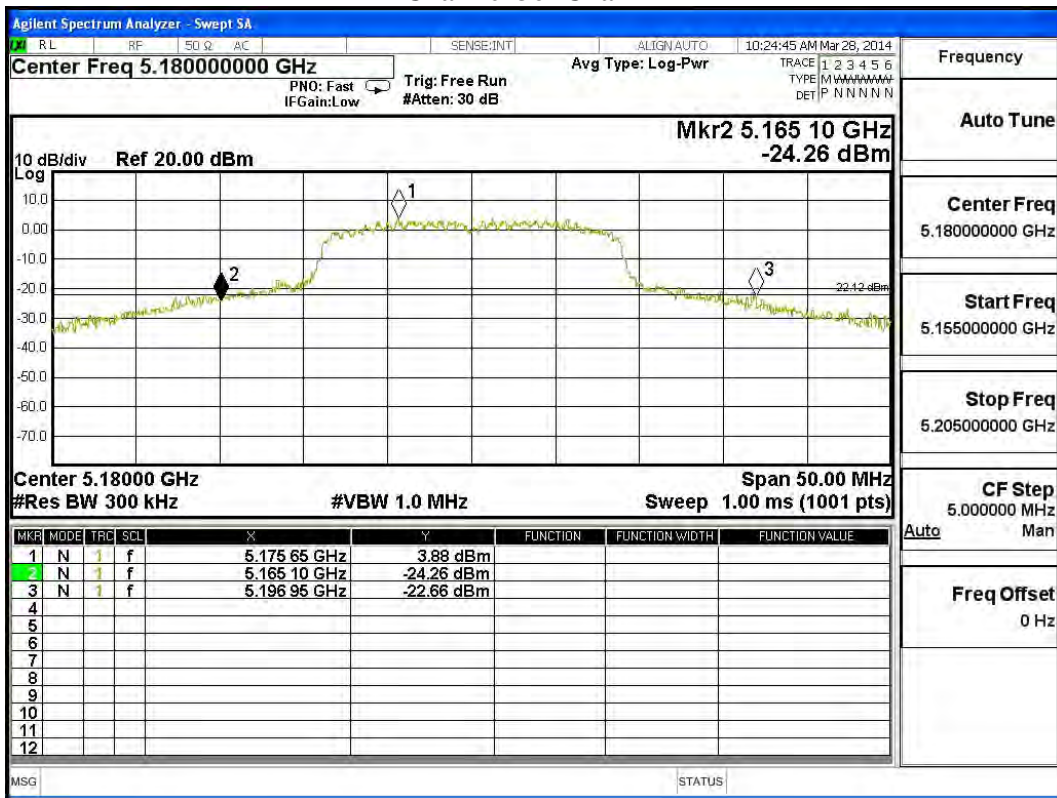

Channel 44 -Chain B

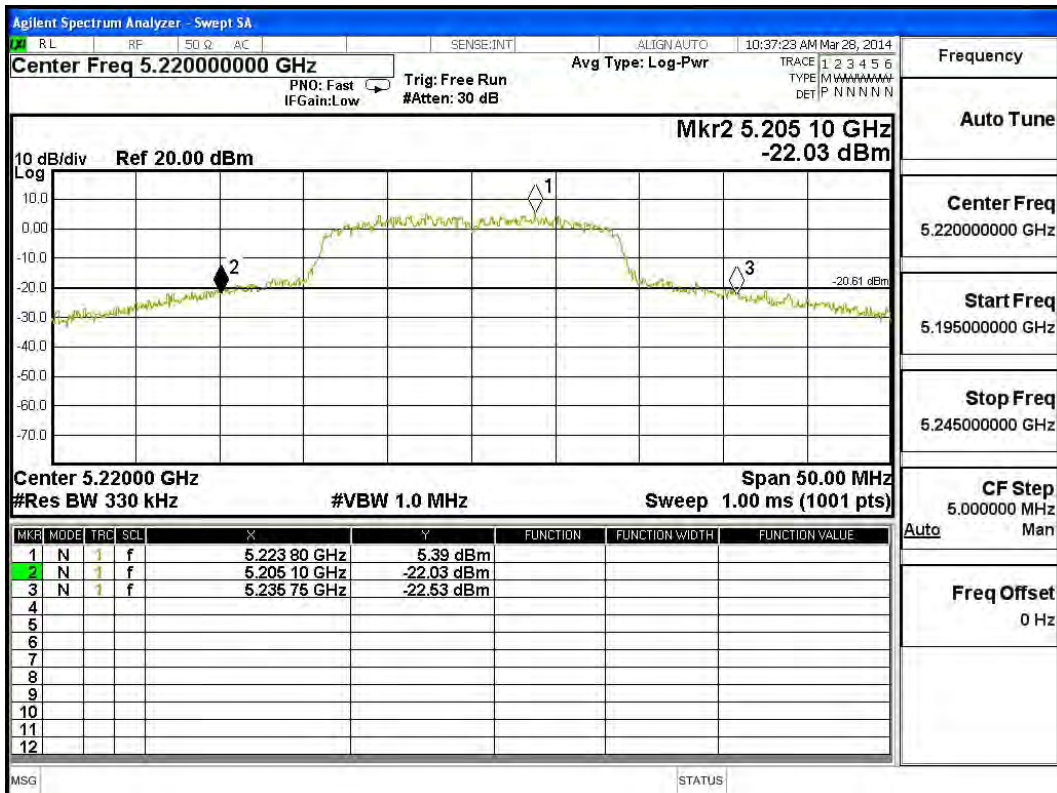

Channel 48 -Chain B

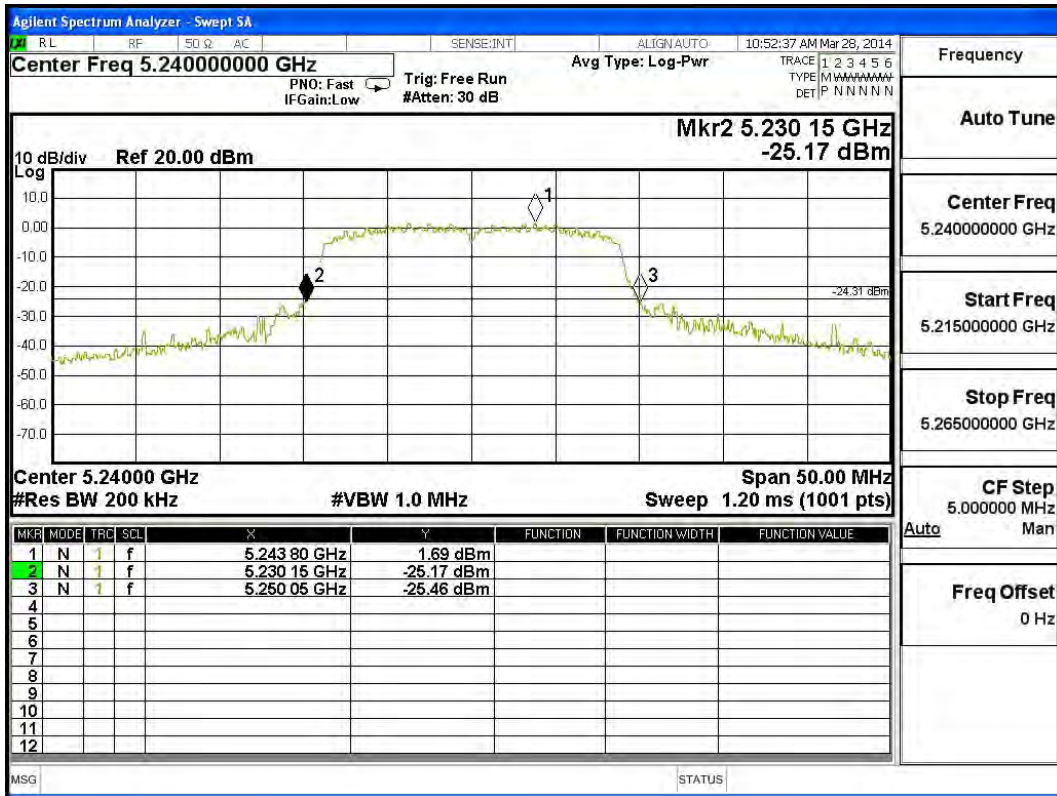

Channel 52 -Chain B

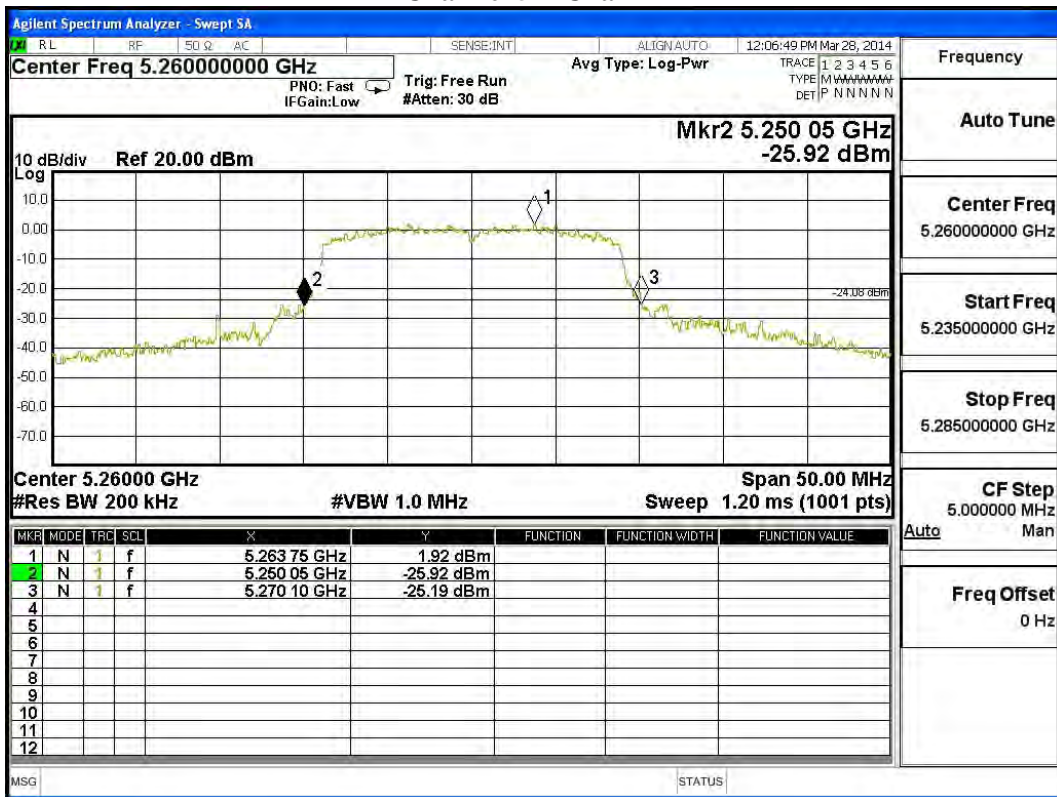

Channel 60 -Chain B

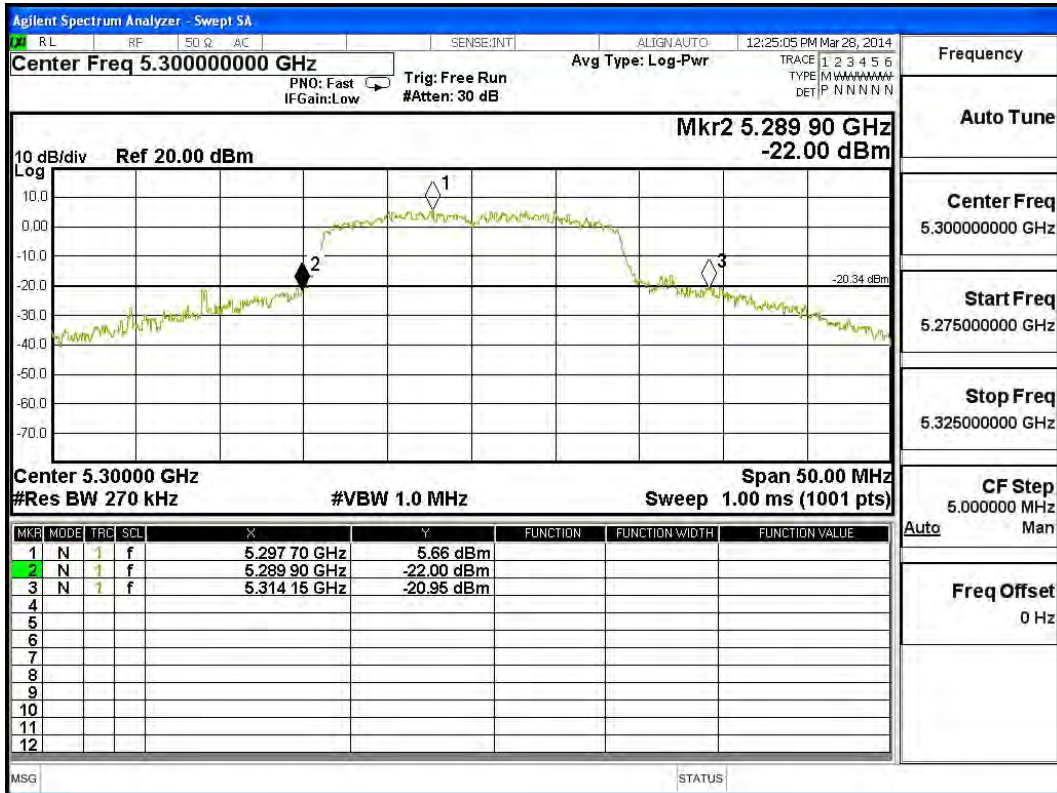

Channel 64 -Chain B

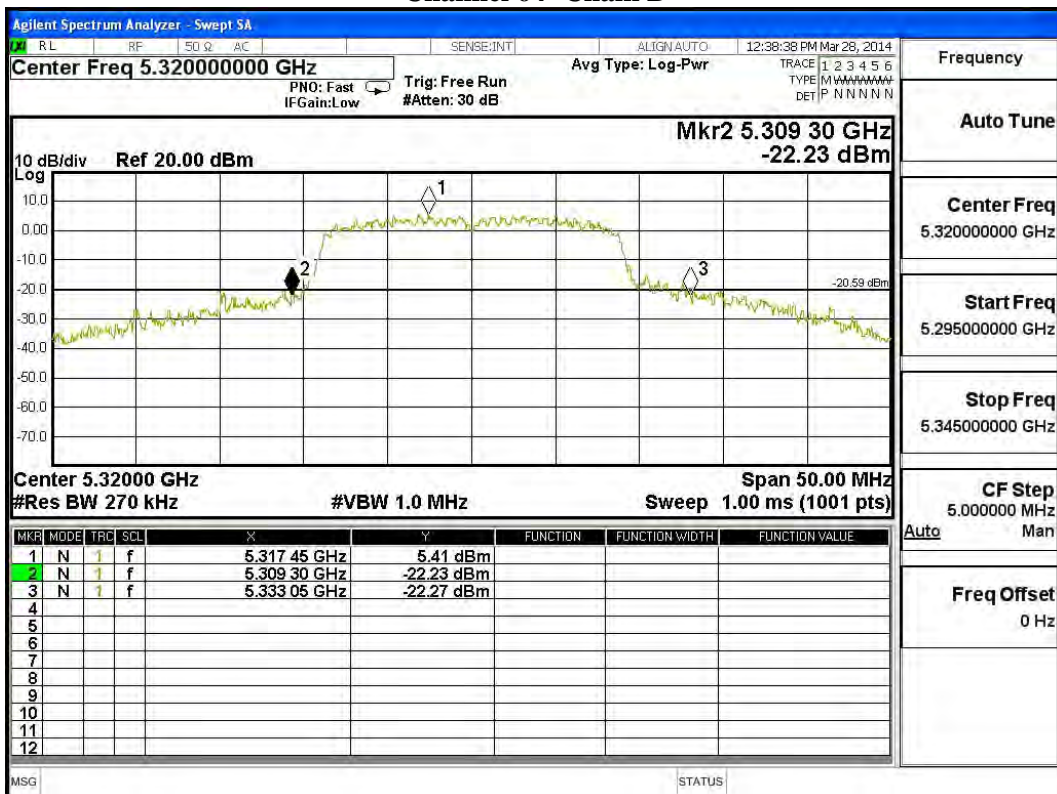

Channel 100 -Chain B

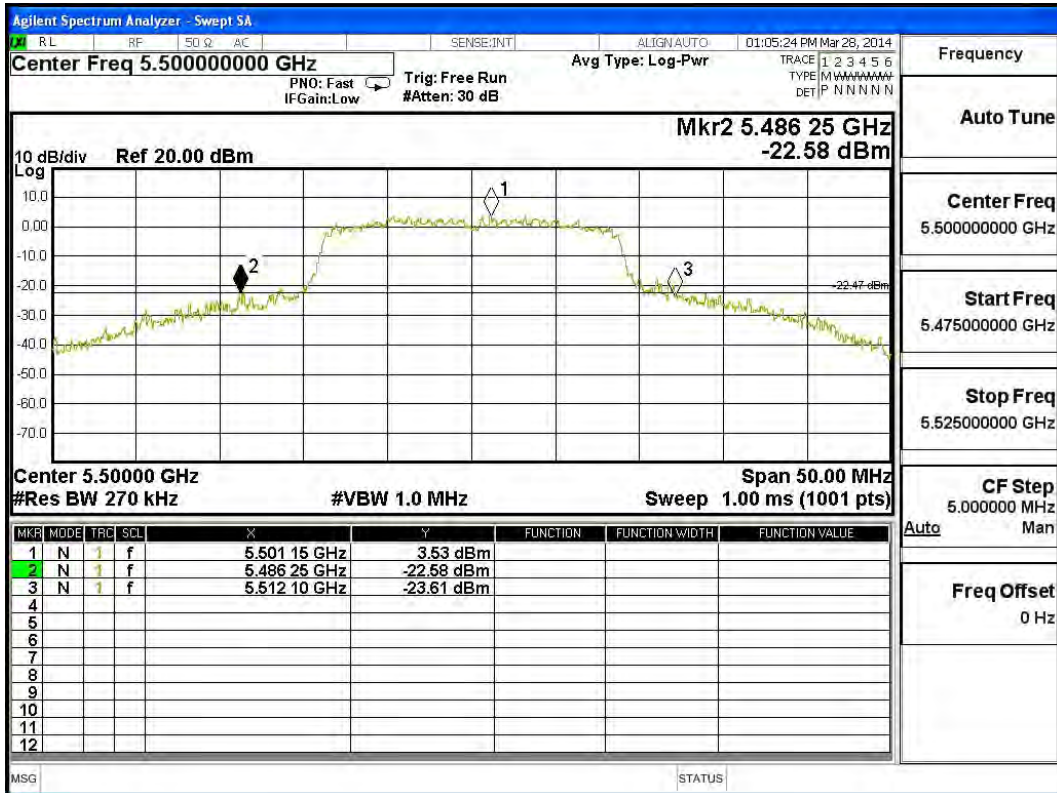

Channel 116 -Chain B

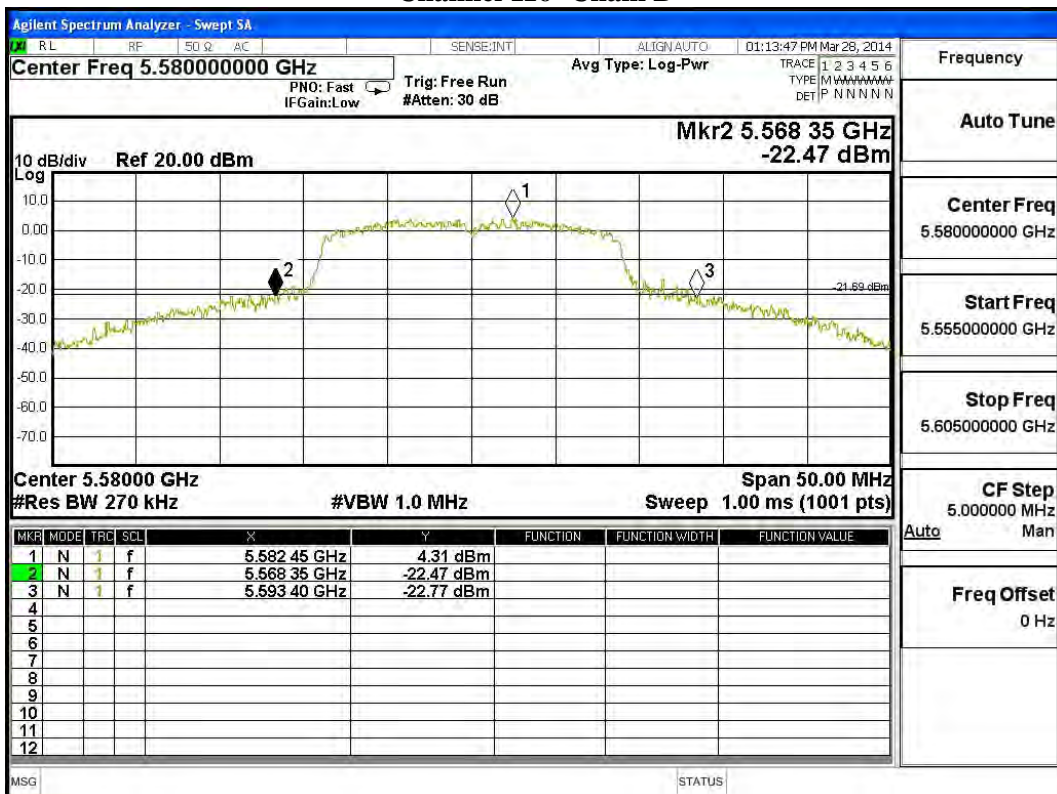

Channel 140 -Chain B

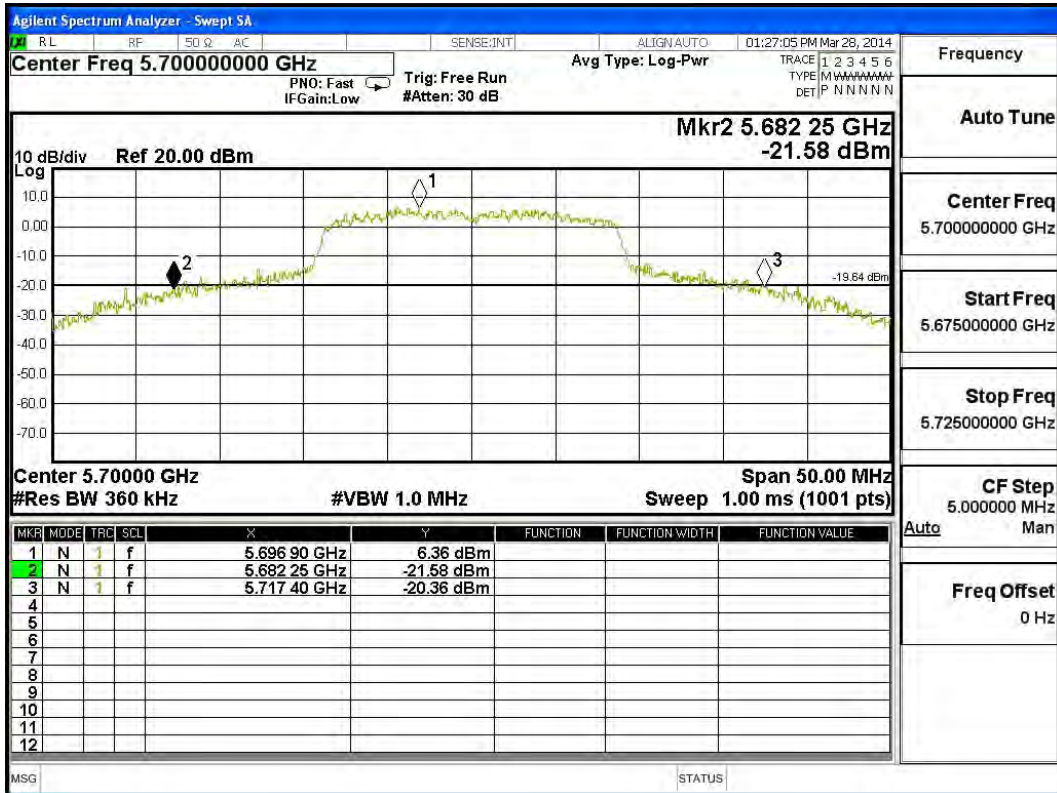

Product : Wireless Motherboard
 Test Item : Maximum conducted output power
 Test Site : No.3 OATS
 Test Mode : Mode 3: Transmit (802.11n-40BW 30Mbps)

CHAIN A

Cable loss=1dB		Maximum conducted output power								
Channel No.	Frequency (MHz)	Data Rate (Mbps)								Required Limit
		30	60	90	120	180	240	270	300	
		Measurement Level (dBm)								
38	5190	12.53	--	--	--	--	--	--	--	<17dBm
46	5230	12.60	12.54	12.48	12.42	12.36	12.3	12.24	12.18	<17dBm
54	5270	12.79	--	--	--	--	--	--	--	<24dBm
62	5310	12.74	12.66	12.58	12.5	12.42	12.34	12.26	12.18	<24dBm
102	5510	12.81	--	--	--	--	--	--	--	<24dBm
110	5550	12.73	12.66	12.59	12.52	12.45	12.38	12.31	12.24	<24dBm
134	5670	12.33	--	--	--	--	--	--	--	<24dBm

Note: Maximum conducted output power Value =Reading value on average power meter + cable loss

CHAIN B

Cable loss=1dB		Maximum conducted output power								
Channel No.	Frequency (MHz)	Data Rate (Mbps)								Required Limit
		30	60	90	120	180	240	270	300	
		Measurement Level (dBm)								
38	5190	12.55	--	--	--	--	--	--	--	<17dBm
46	5230	12.21	12.14	12.07	12	11.93	11.86	11.79	11.72	<17dBm
54	5270	11.96	--	--	--	--	--	--	--	<24dBm
62	5310	11.77	11.69	11.61	11.53	11.45	11.37	11.29	11.21	<24dBm
102	5510	12.49	--	--	--	--	--	--	--	<24dBm
110	5550	12.69	12.61	12.53	12.45	12.37	12.29	12.21	12.13	<24dBm
134	5670	13.17	--	--	--	--	--	--	--	<24dBm

Note: Maximum conducted output power Value =Reading value on average power meter + cable loss

Maximum conducted output power Measurement:
(CHAIN A+ B)

Channel Number	Frequency (MHz)	26dB Bandwidth (MHz)	Chain A Power (dBm)	Chain B Power (dBm)	Output Power (dBm)	Output Power Limit	
						(dBm)	dBm+10log(BW)
38	5190	45.600	12.53	12.55	15.55	17	20.59
46	5230	45.800	12.60	12.21	15.42	17	20.61
54	5270	47.800	12.79	11.96	15.41	24	27.79
62	5310	46.300	12.74	11.77	15.29	24	27.66
102	5510	45.800	12.81	12.49	15.66	24	27.61
110	5550	46.500	12.73	12.69	15.72	24	27.67
134	5670	62.000	12.33	13.17	15.78	24	28.92

Note:

1. Power Output Value =Reading value on average power meter + cable loss
2. Output Power (dBm) = 10LOG (Chain A Power (mW)+ Chain B Power (mW))
3. 26 dB Bandwidth is the bandwidth of chain A or chain B whichever is less bandwidth, output power limitation is more stringent.

26dBc Occupied Bandwidth: Channel 38 – Chain A

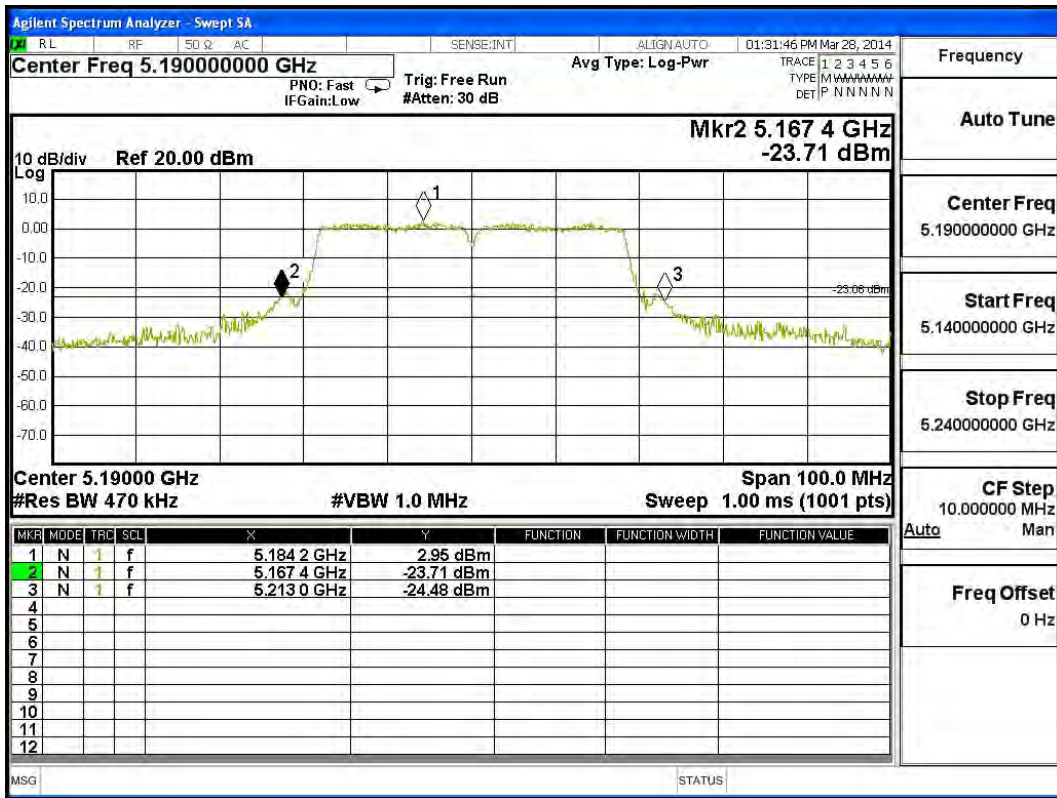

Channel 46 – Chain A

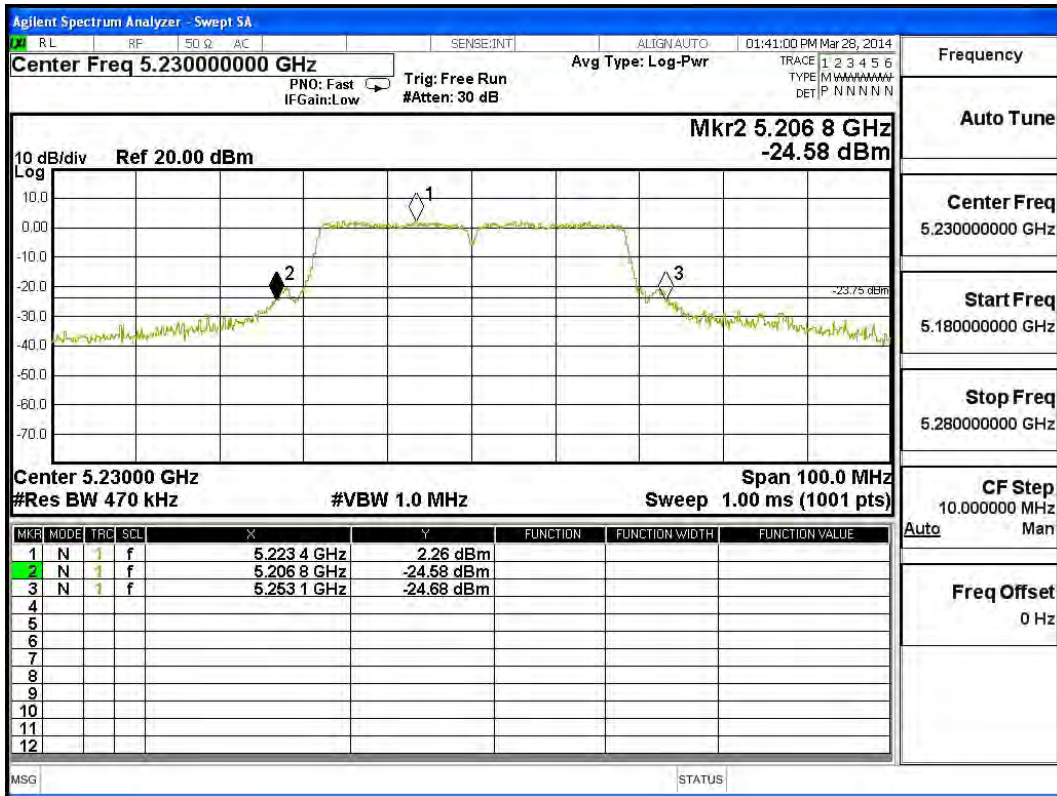

Channel 54 – Chain A

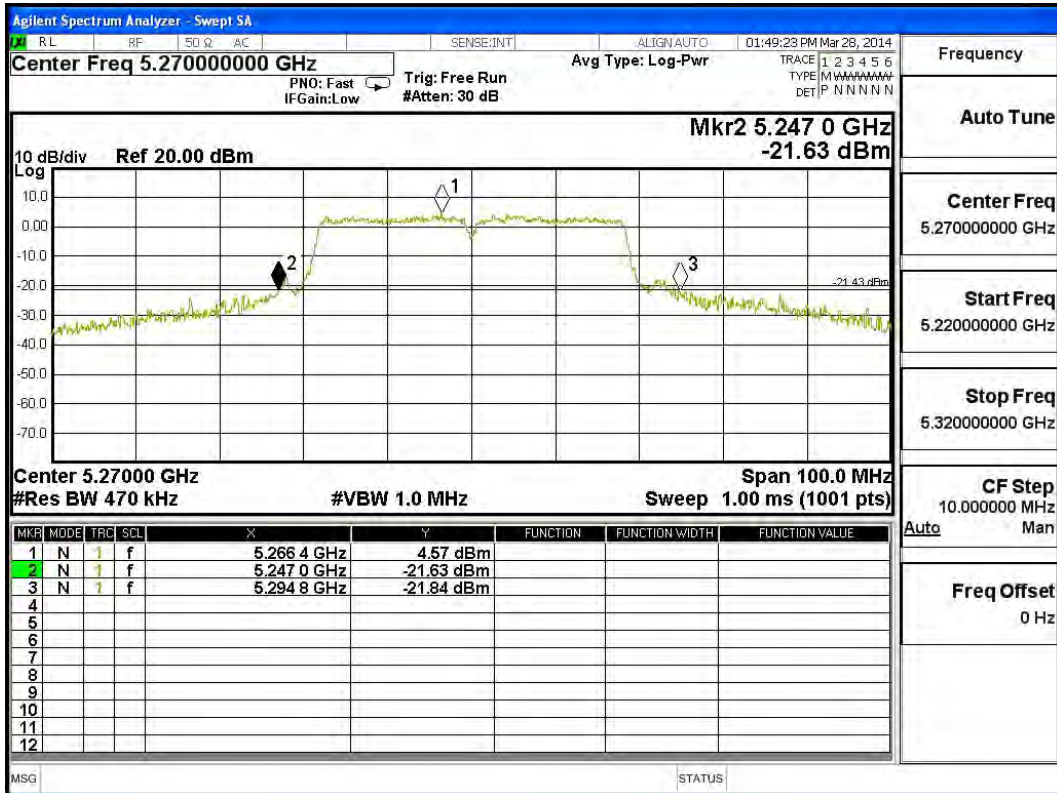

Channel 62 – Chain A

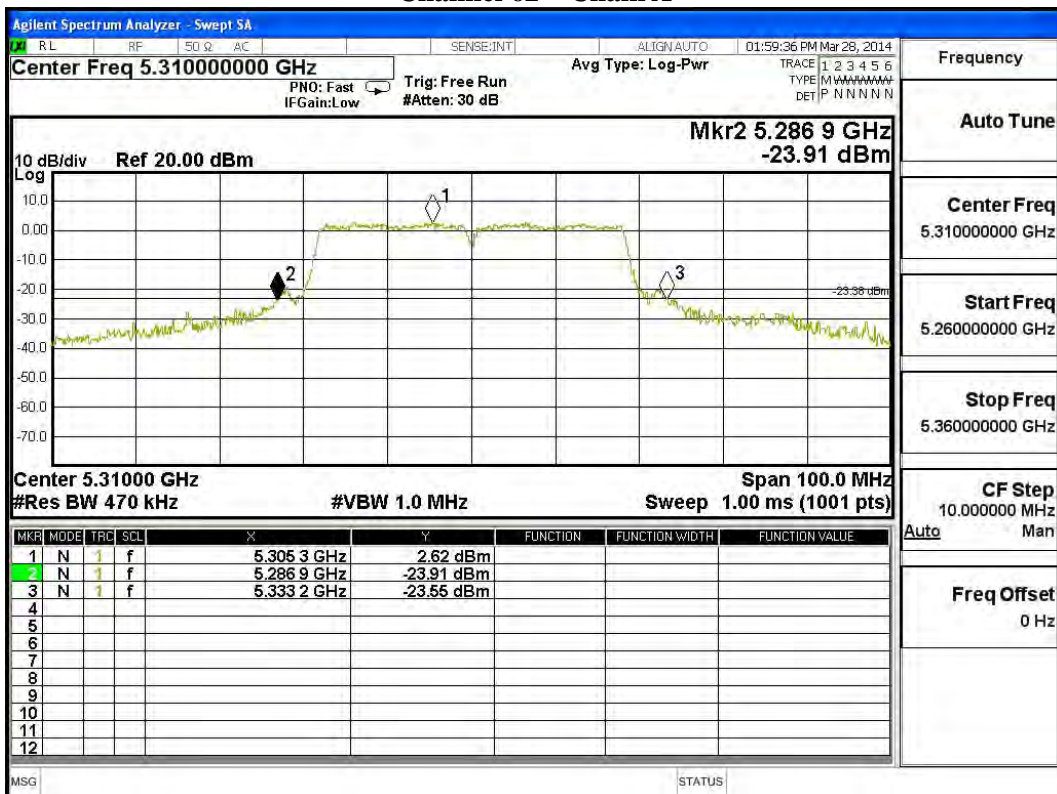

Channel 102 – Chain A

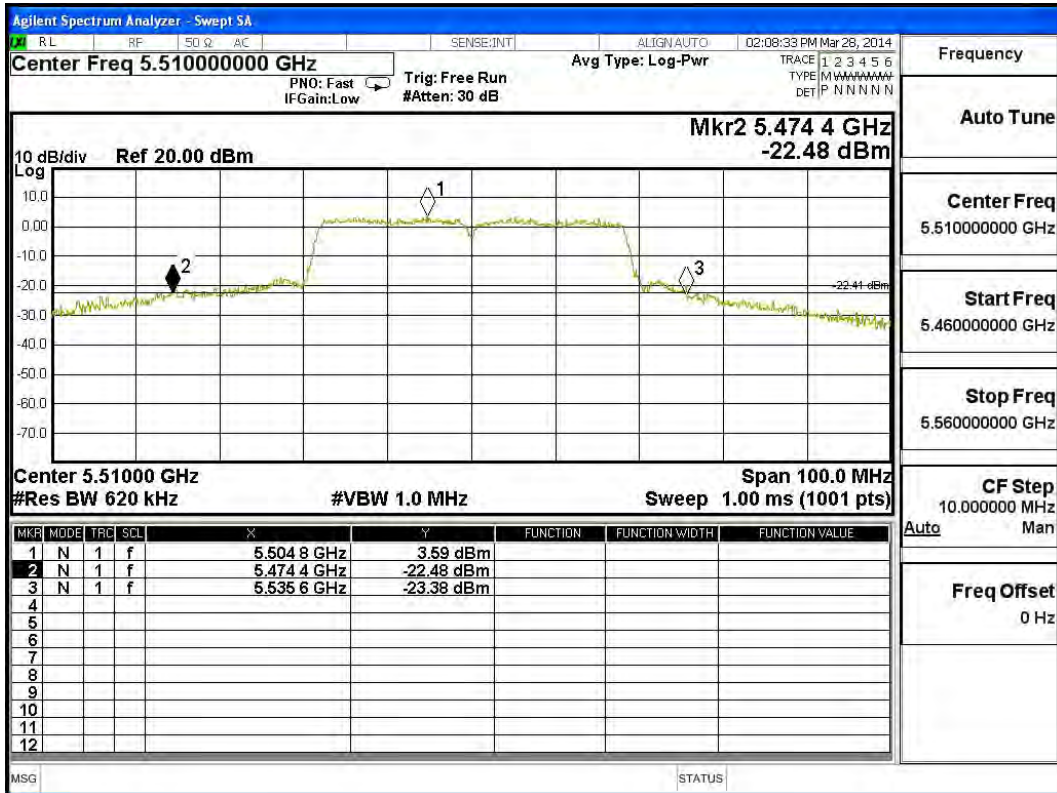

Channel 110 – Chain A

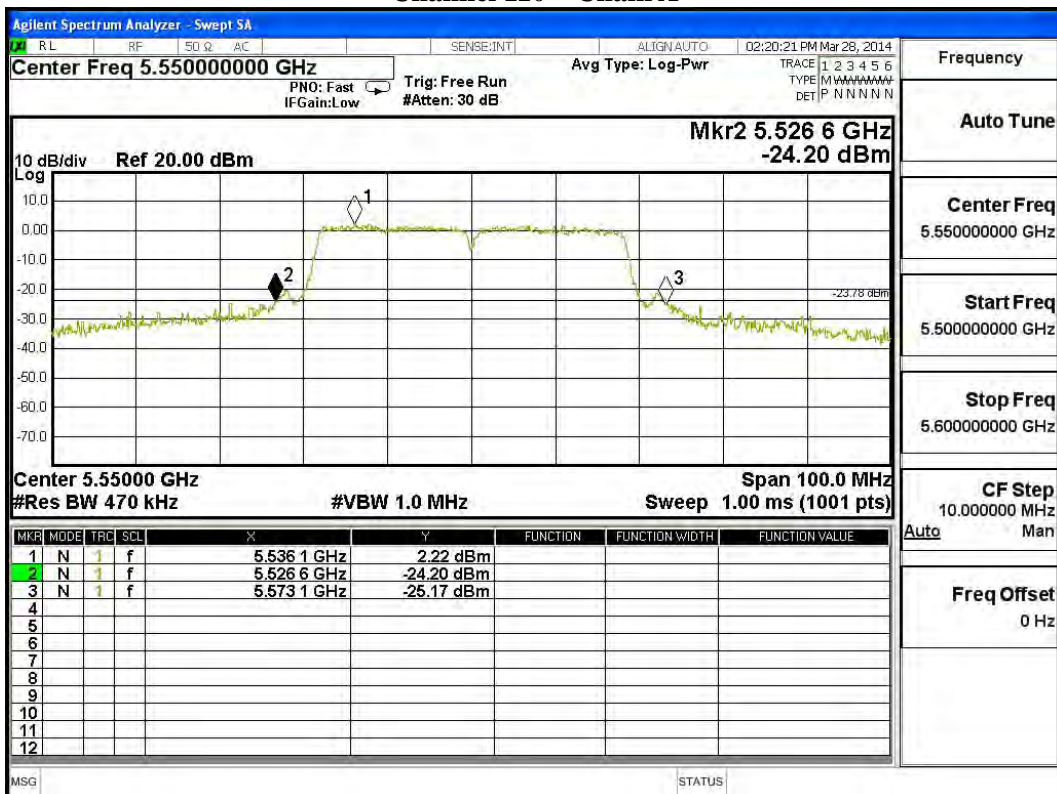

Channel 134 – Chain A

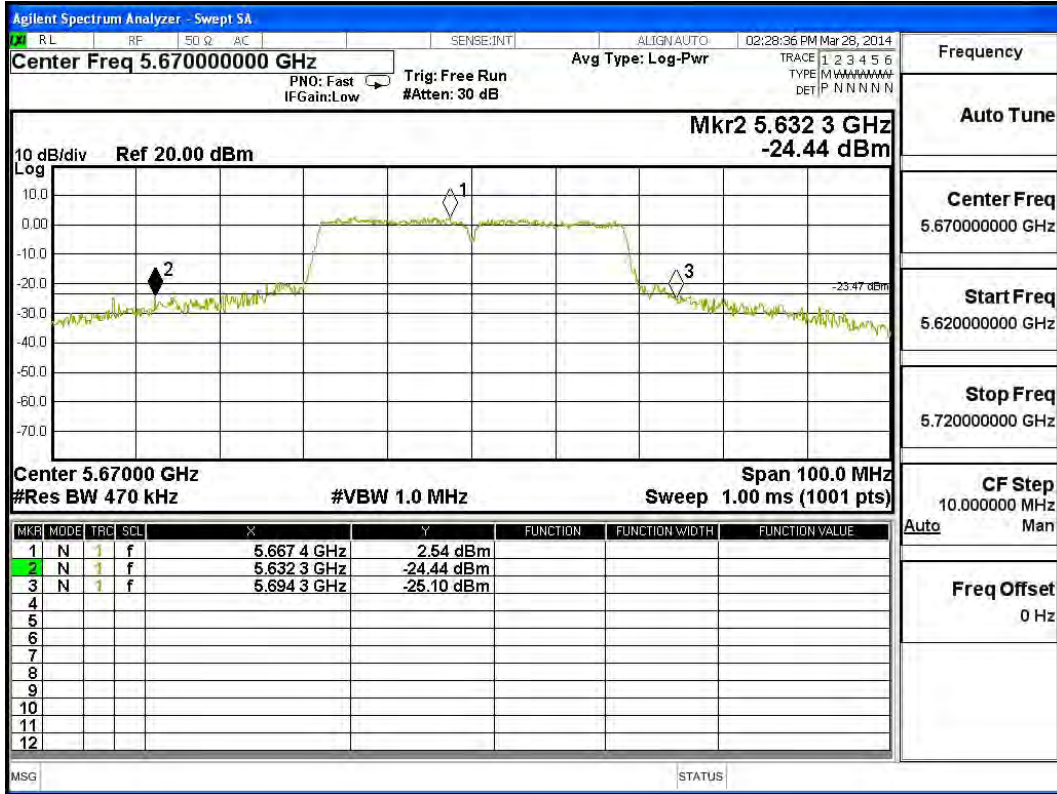

26dBc Occupied Bandwidth: Channel 38 – Chain B

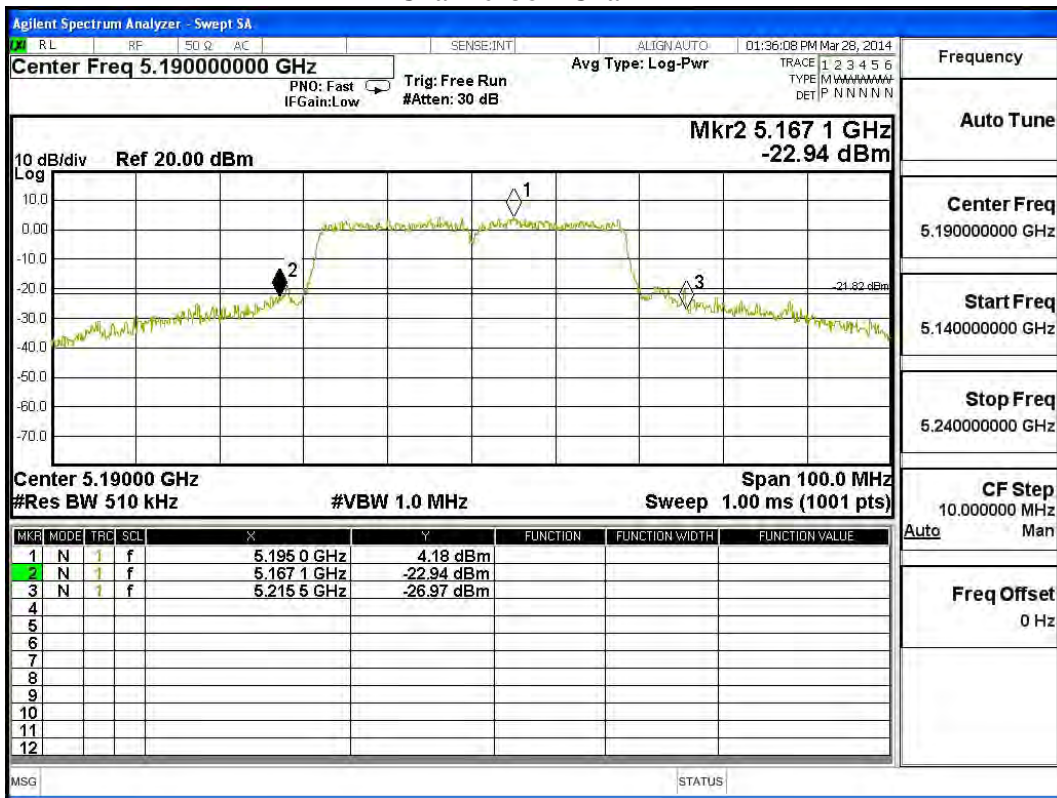

Channel 46 – Chain B

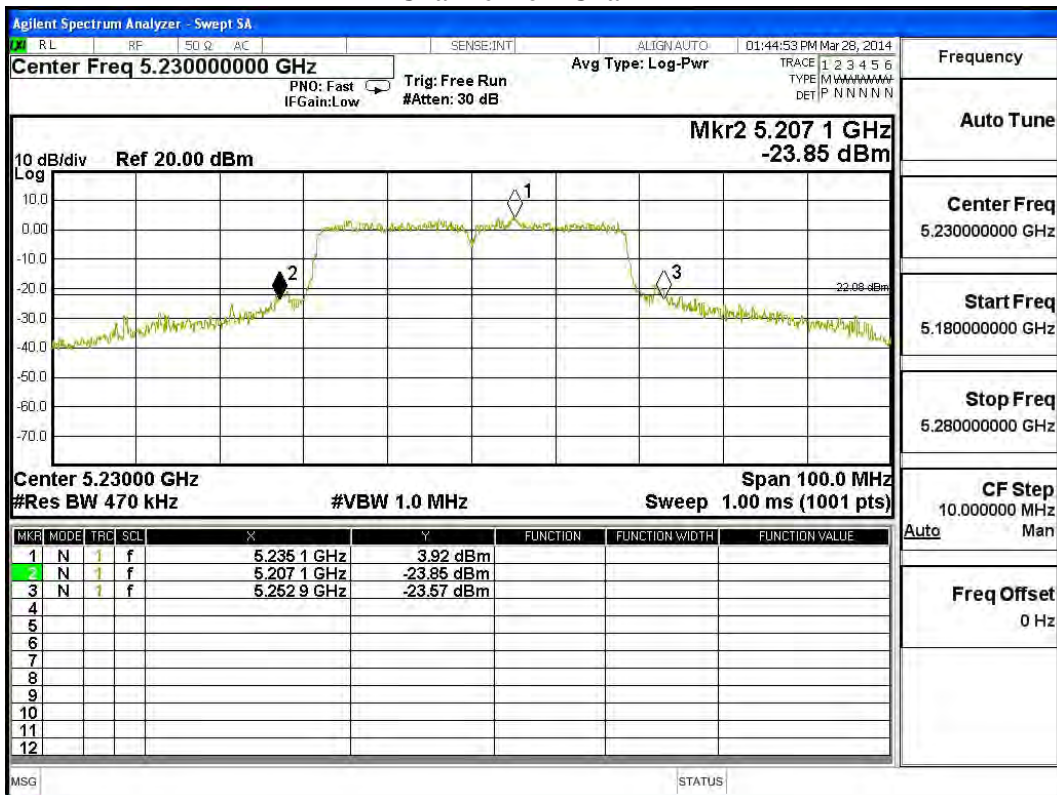

Channel 54 – Chain B

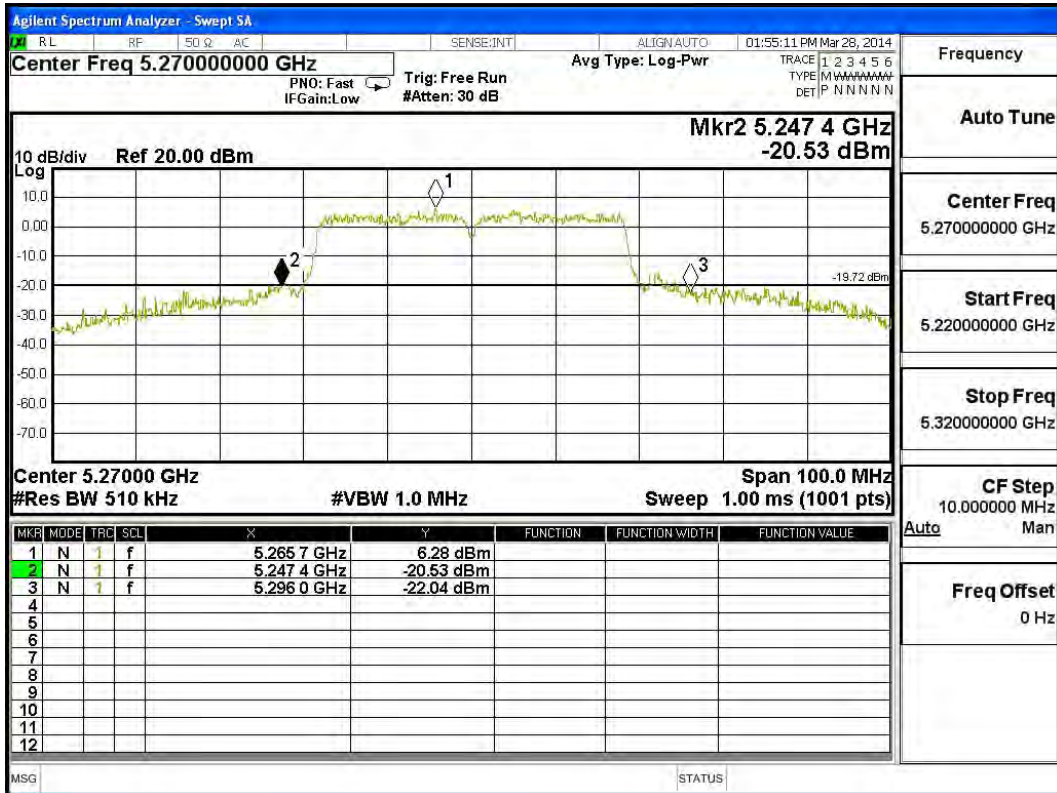

Channel 62 – Chain B

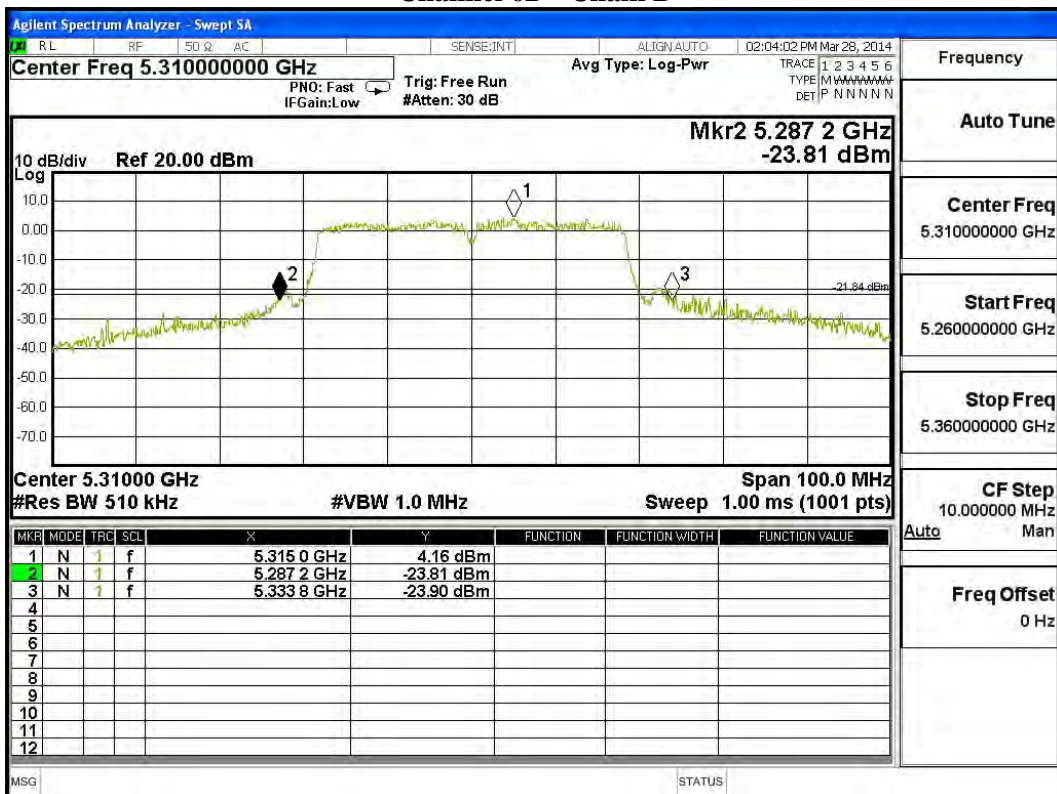

Channel 102 – Chain B

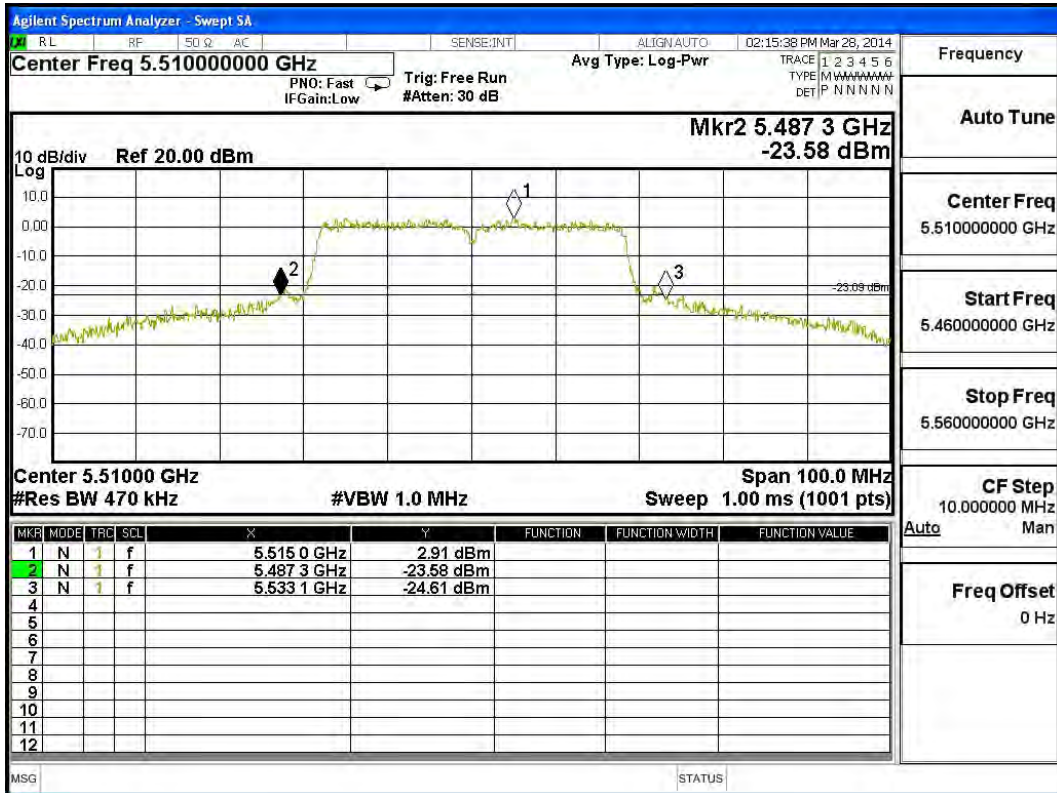

Channel 110 – Chain B

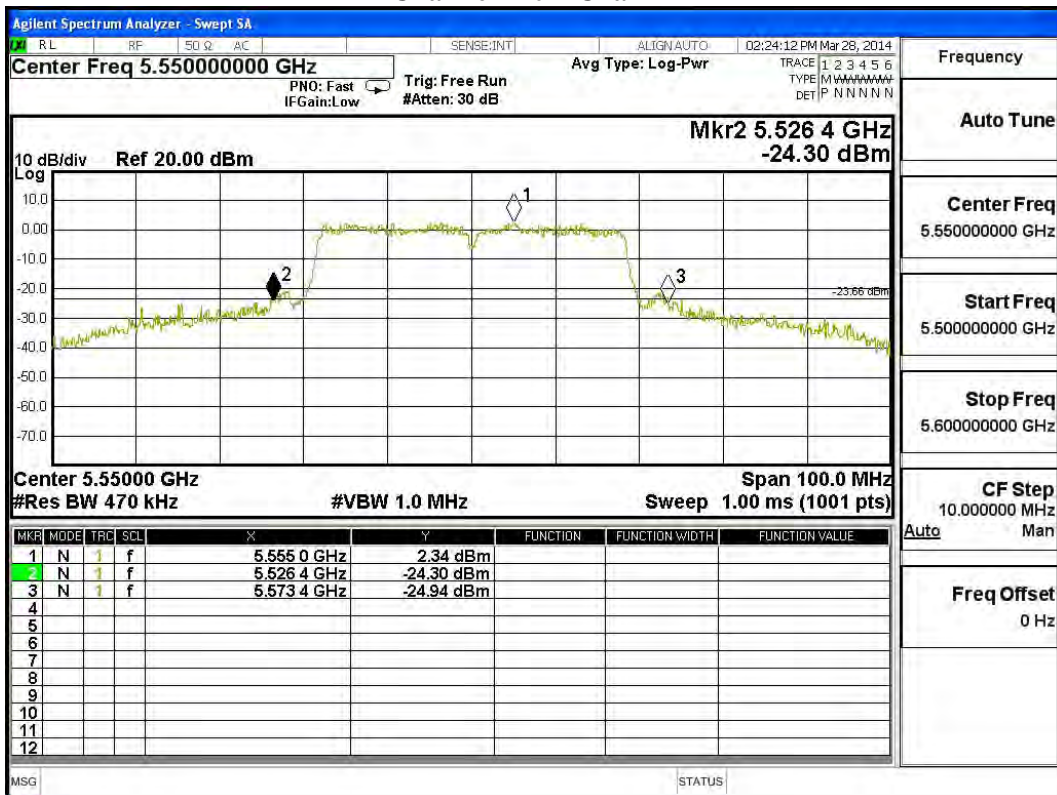

Channel 134 – Chain B

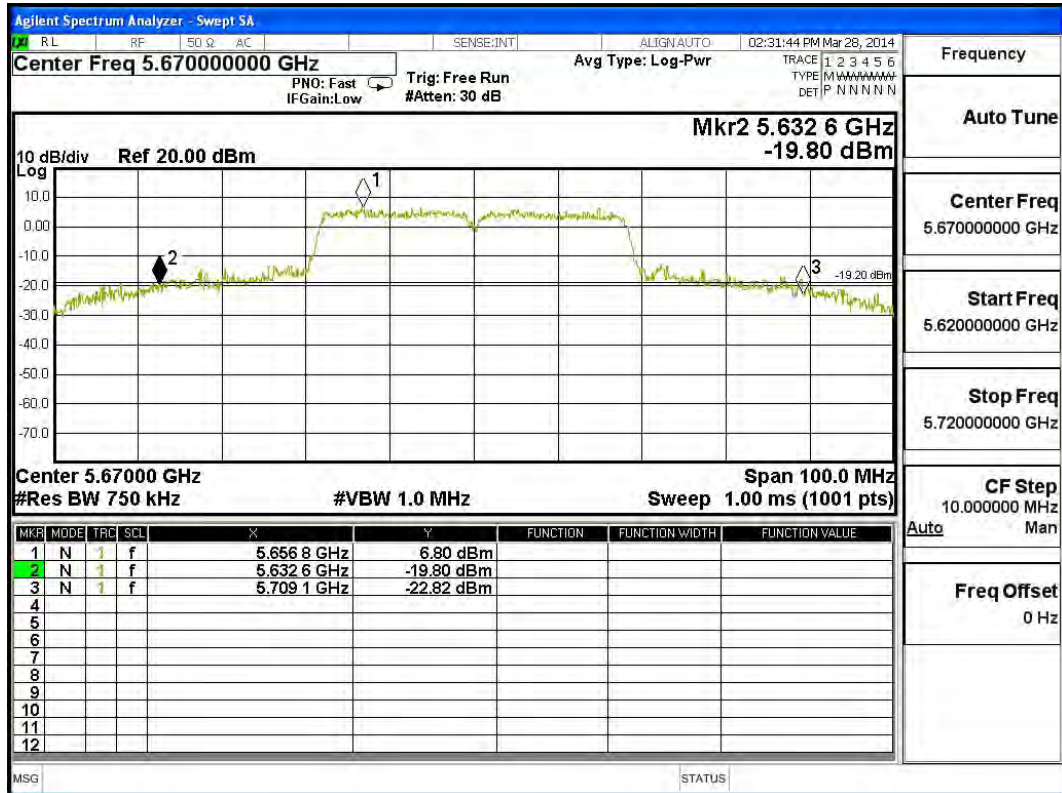

4. Peak Power Spectral Density

4.1. Test Equipment

	Equipment	Manufacturer	Model No./Serial No.	Last Cal.
	Spectrum Analyzer	R&S	FSP40 / 100170	Jun, 2013
	Spectrum Analyzer	Agilent	E4407B / US39440758	Jun, 2013
X	Spectrum Analyzer	Agilent	N9010A / MY48030495	Apr, 2014

Note:

1. All equipments are calibrated with traceable calibrations. Each calibration is traceable to the national or international standards.
2. The test instruments marked with “X” are used to measure the final test results.

4.2. Test Setup

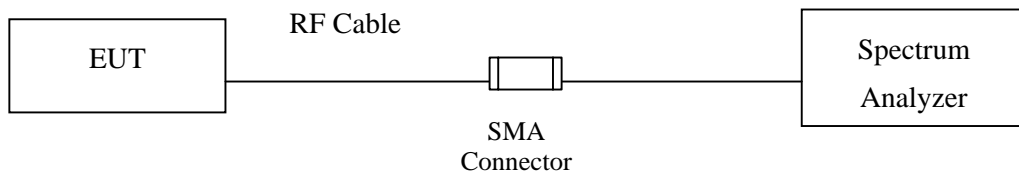

4.3. Limits

- (1) For the band 5.15-5.25 GHz, the peak power spectral density shall not exceed 4 dBm in any 1-MHz band. If transmitting antenna of directional gain greater than 6 dBi are used, the peak power spectral density shall be reduced by the amount in dB that directional gain of the antenna exceeds 6 dBi.
- (2) For the band 5.25-5.35 GHz, the peak power spectral density shall not exceed 11 dBm in any 1-MHz band. If transmitting antenna of directional gain greater than 6 dBi are used, the peak power spectral density shall be reduced by the amount in dB that directional gain of the antenna exceeds 6 dBi.
- (3) For the band 5.725-5.825 GHz, the peak power spectral density shall not exceed 17 dBm in any 1-MHz band. If transmitting antenna of directional gain greater than 6 dBi are used, the peak power spectral density shall be reduced by the amount in dB that directional gain of the antenna exceeds 6 dBi.

4.4. Test Procedure

The EUT was setup to ANSI C63.10, 2009; tested to DTS test procedure of FCC KDB-789033 for compliance to FCC 47CFR Subpart E requirements.

The Peak Power Spectral Density using KDB 789033 section F) procedure, Create an average power spectrum for the EUT operating mode being tested by following the instructions in section E)2) for measuring maximum conducted output power using a spectrum analyzer.

SA-1 method is selected to run the test.

4.5. Uncertainty

± 1.27 dB

4.6. Test Result of Peak Power Spectral Density

Product : Wireless Motherboard
 Test Item : Peak Power Spectral Density
 Test Site : No.3 OATS
 Test Mode : Mode 1: Transmit (802.11a-6Mbps)

Channel Number	Frequency (MHz)	Data Rate (Mbps)	Measurement Level (dBm)	Required Limit (dBm)	Result
36	5180	6	3.430	<4	Pass
44	5220	6	3.690	<4	Pass
48	5240	6	3.680	<4	Pass
52	5260	6	4.330	<11	Pass
60	5300	6	4.150	<11	Pass
64	5320	6	4.690	<11	Pass
100	5500	6	3.270	<11	Pass
116	5580	6	3.510	<11	Pass
140	5700	6	3.040	<11	Pass

Channel 36:

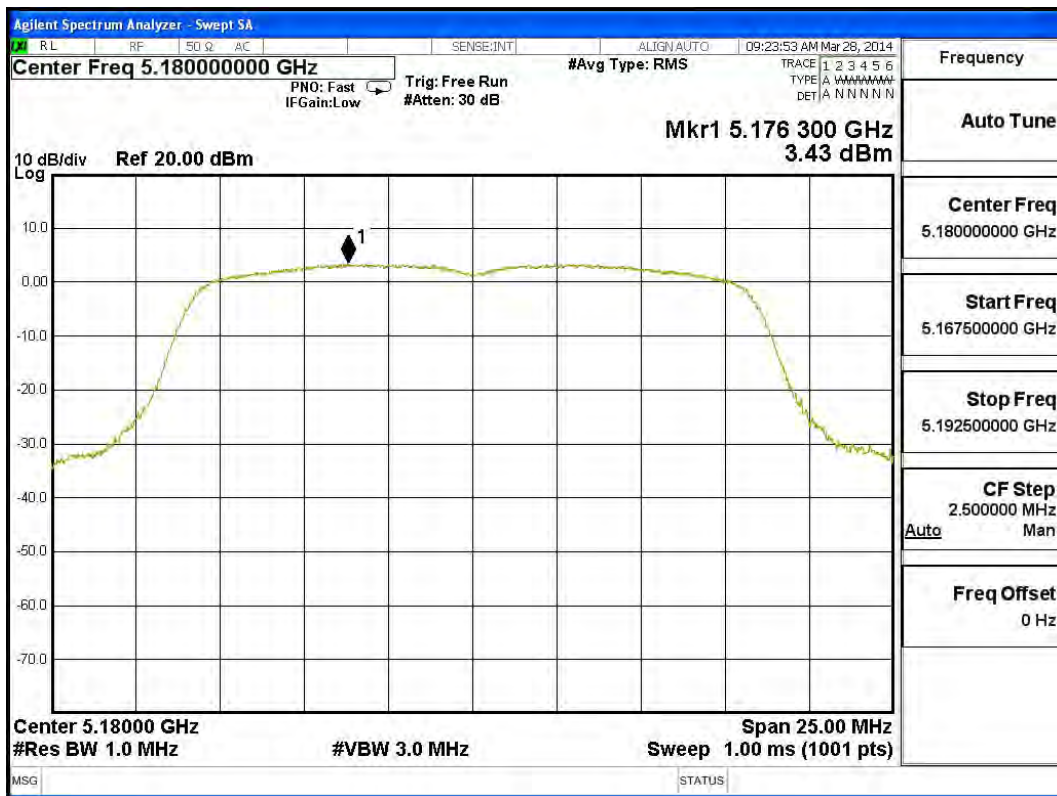

Channel 44:

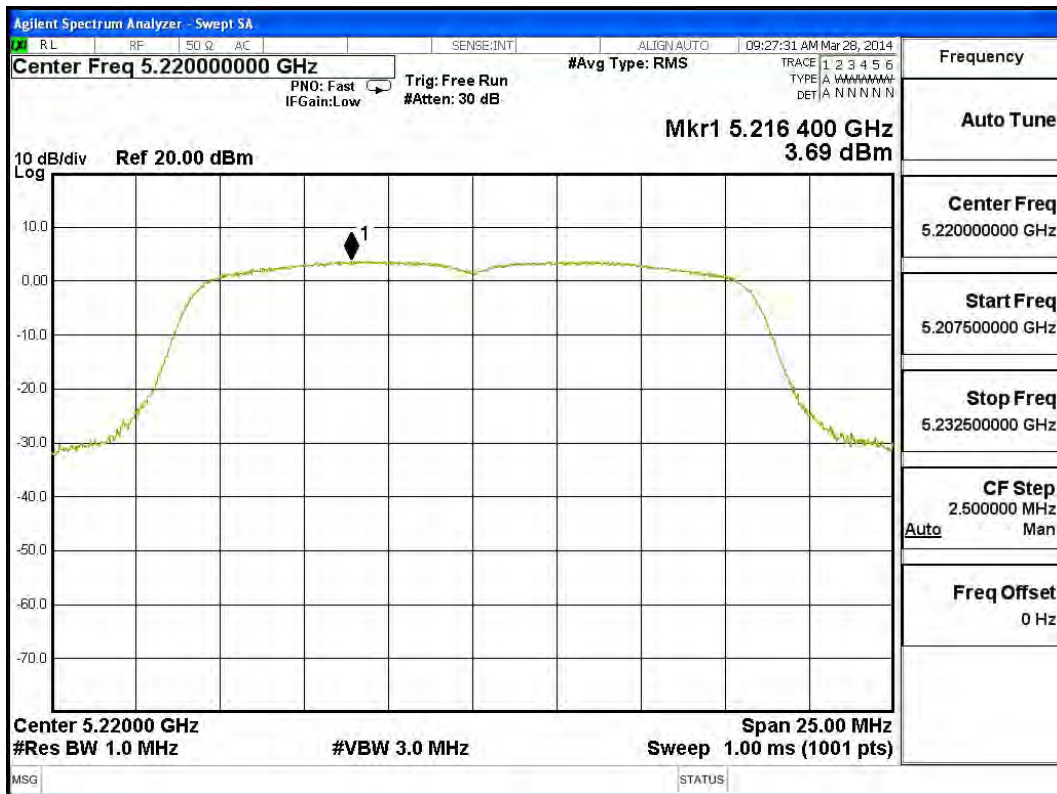

Channel 48:

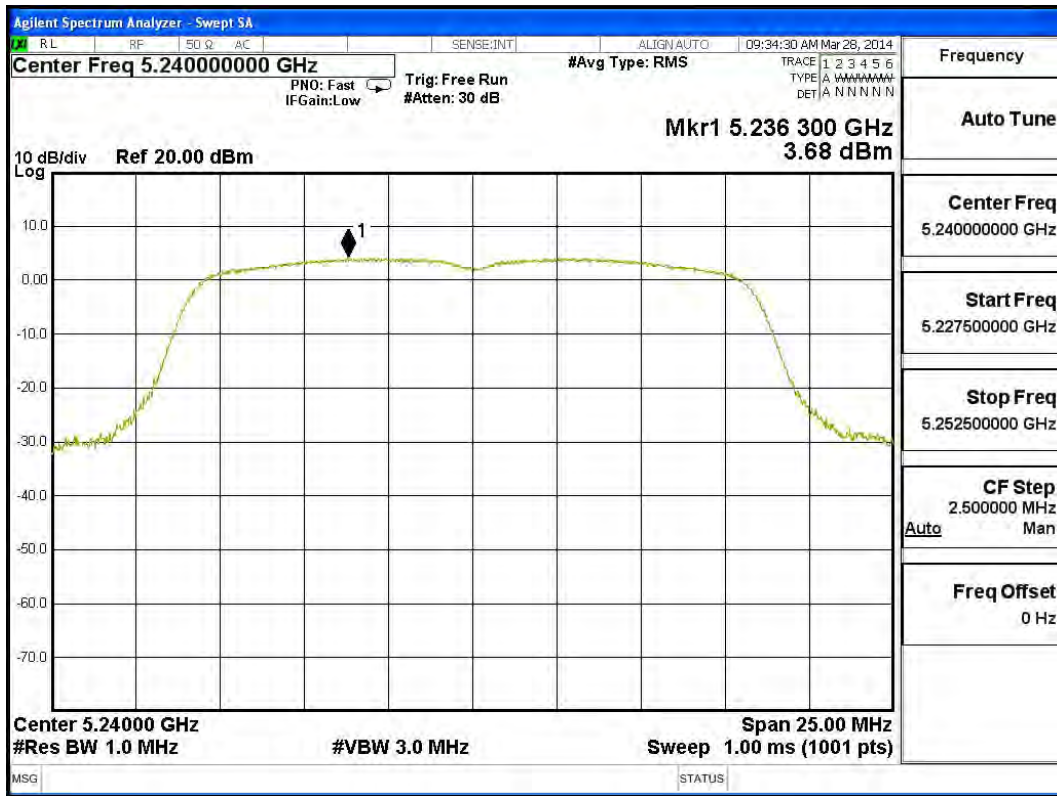

Channel 52:

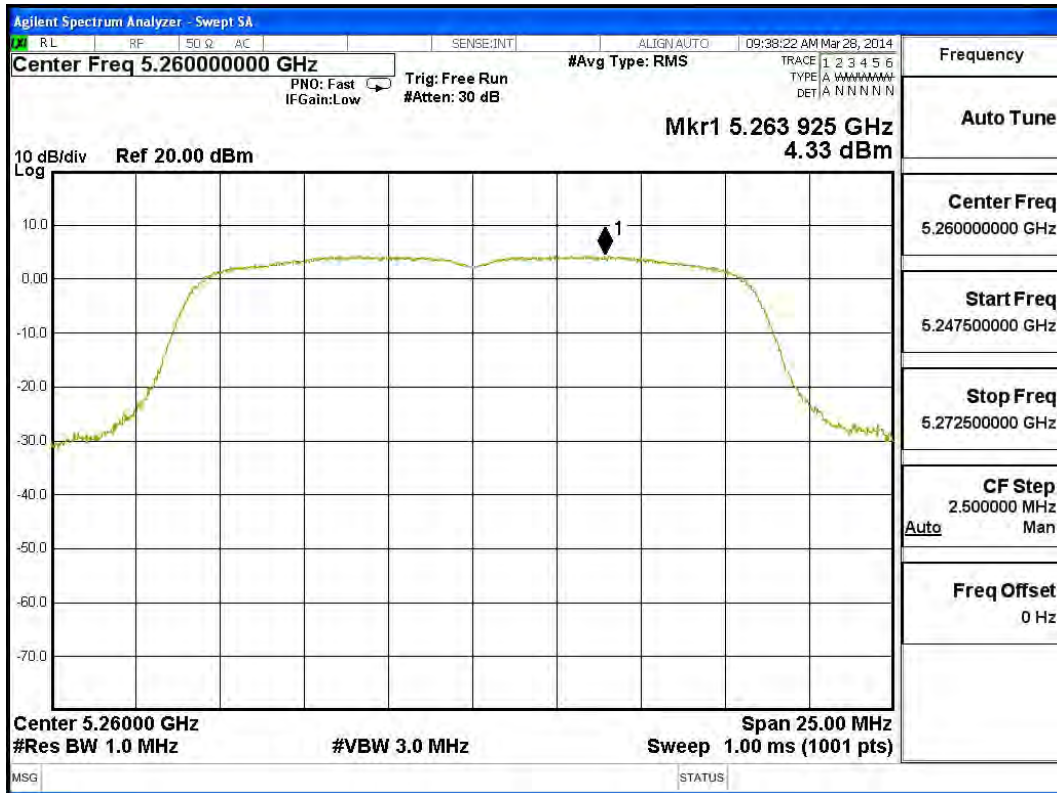

Channel 60:

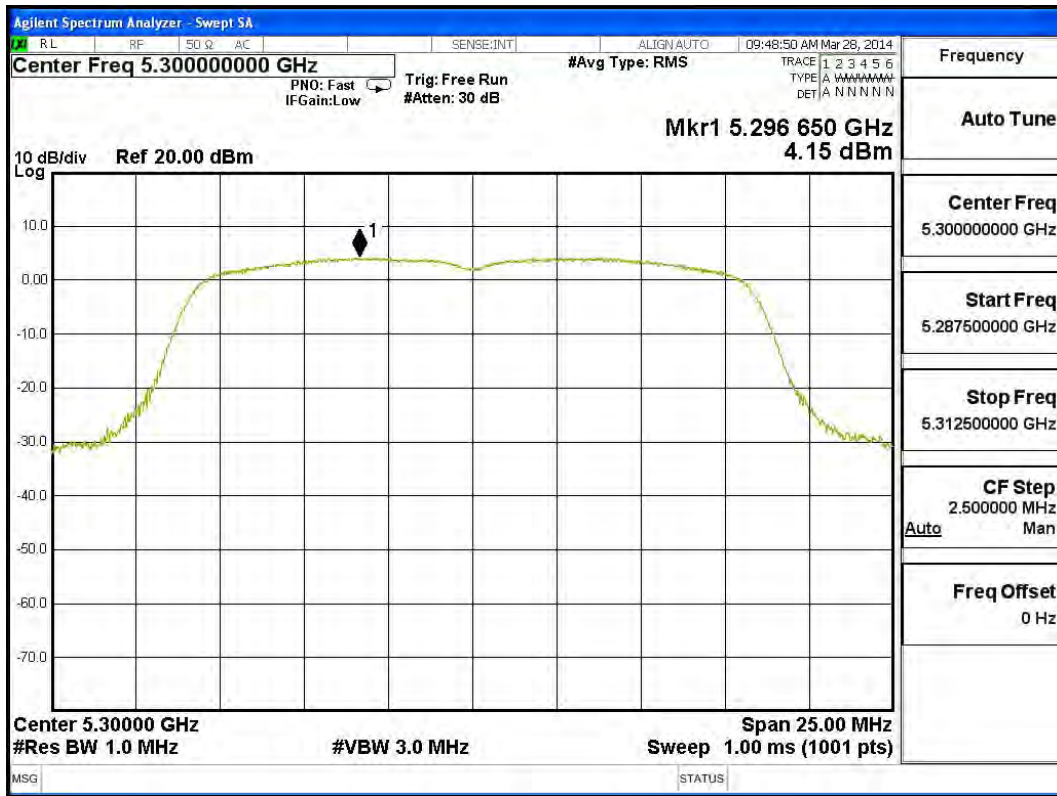

Channel 64:

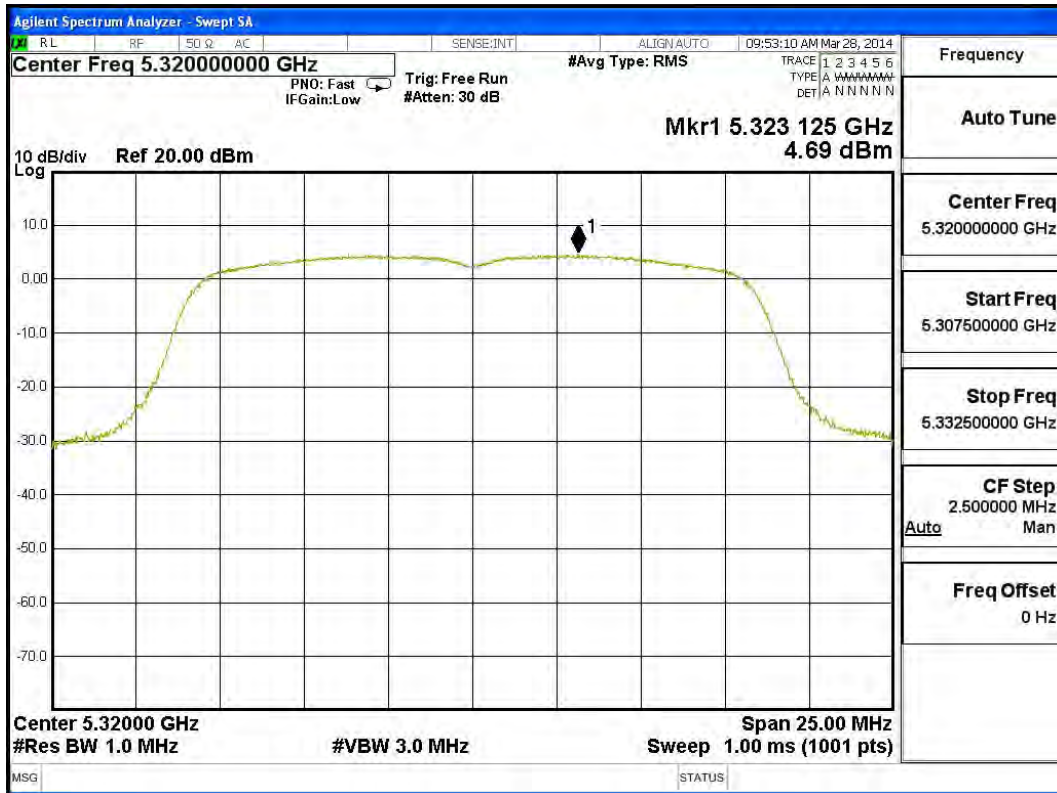

Channel 100:

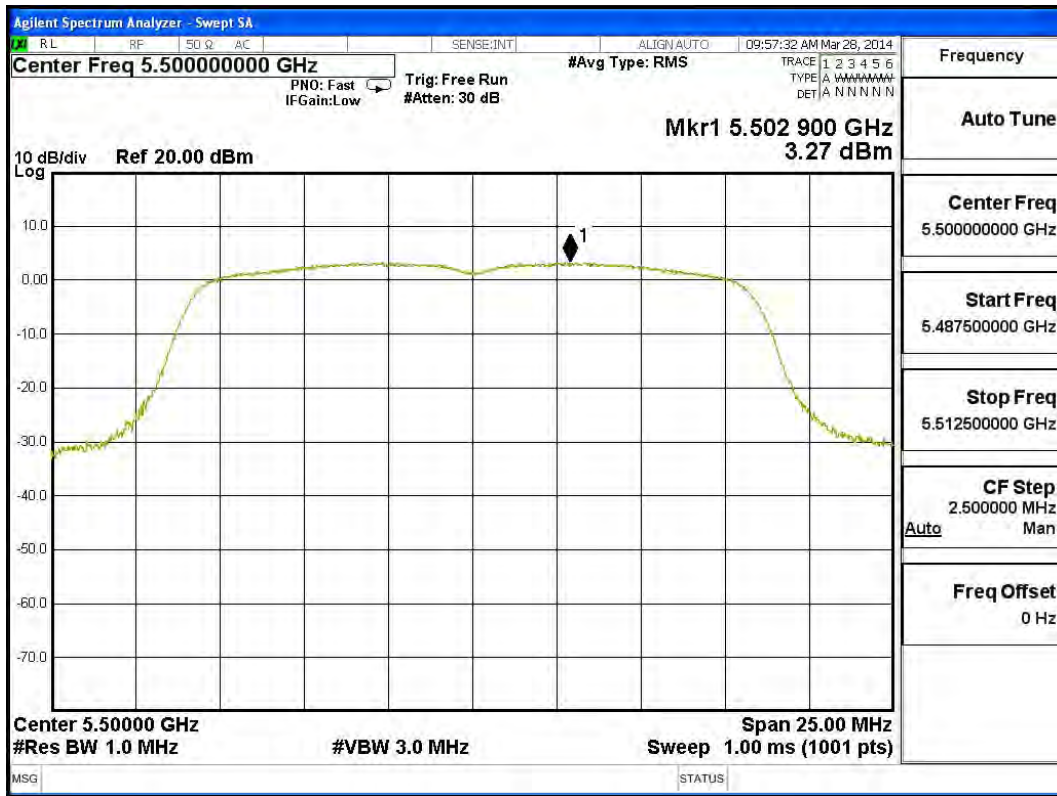

Channel 116:

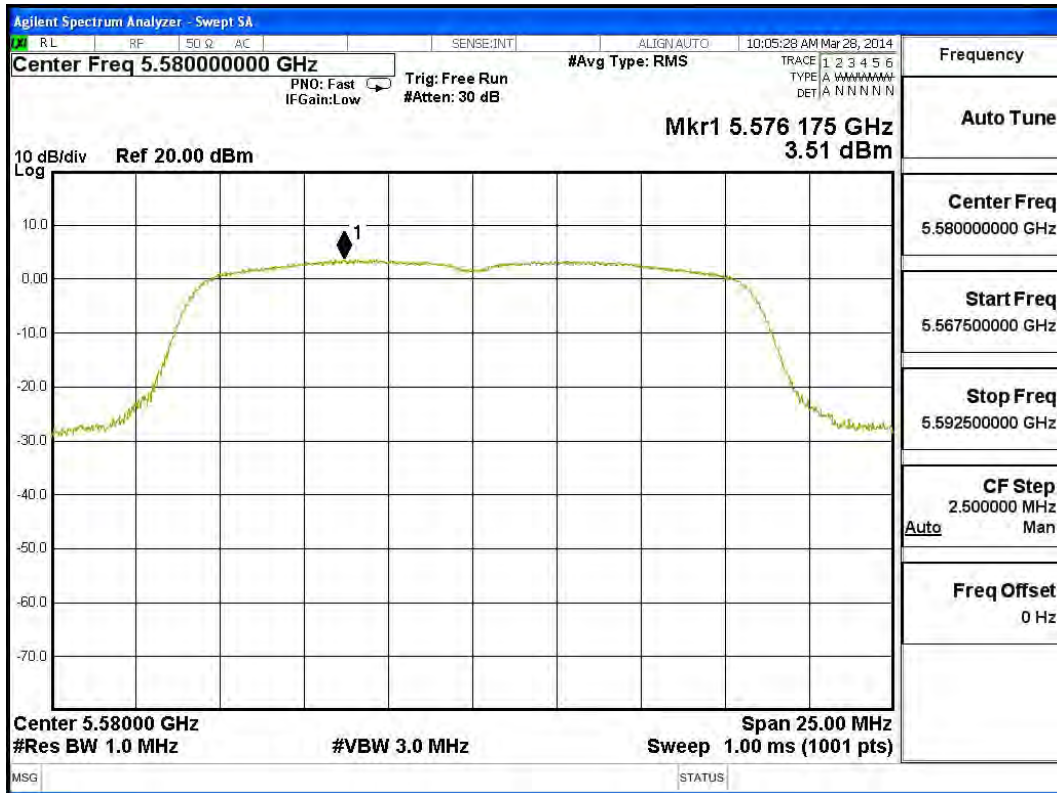

Channel 140:

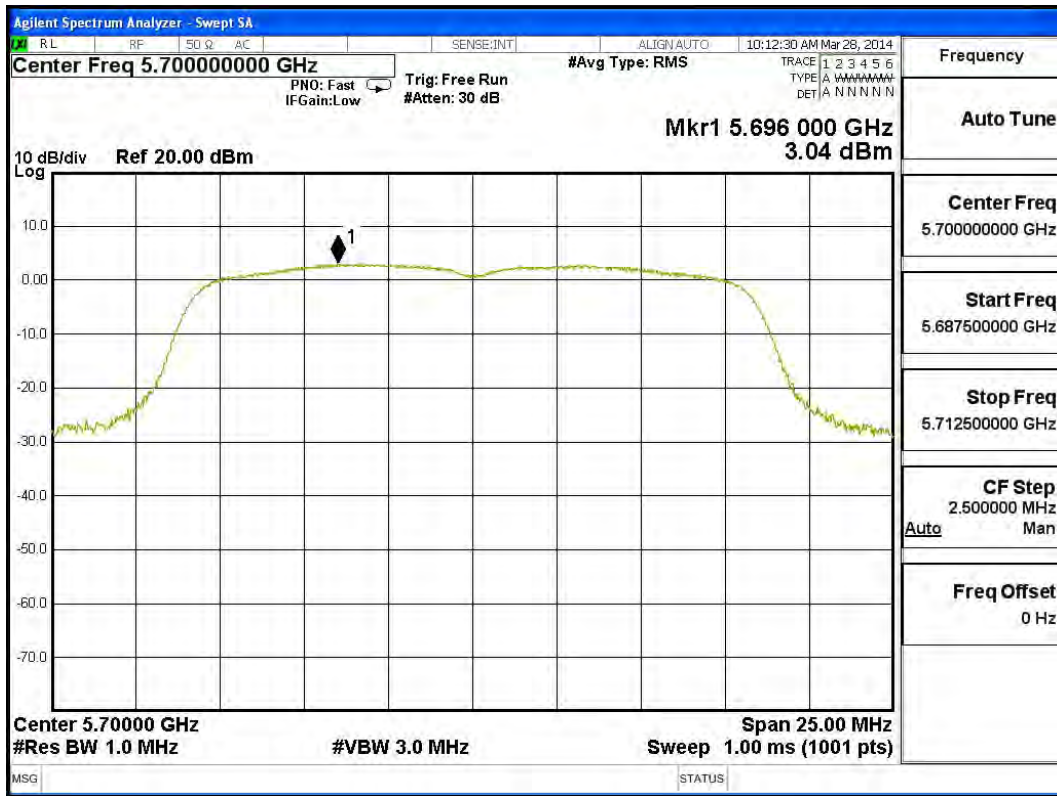

Product : Wireless Motherboard
 Test Item : Peak Power Spectral Density
 Test Site : No.3 OATS
 Test Mode : Mode 2: Transmit (802.11n-20BW 14.4Mbps)

Channel Number	Frequency (MHz)	Chain	PPSD/MHz (dBm)	Total PPSD/MHz (dBm) ¹	Required Limit (dBm)	Result
36	5180	A	0.180	3.190	<4	Pass
		B	0.290	3.300	<4	Pass
44	5220	A	0.840	3.850	<4	Pass
		B	0.360	3.370	<4	Pass
48	5240	A	0.760	3.770	<4	Pass
		B	0.450	3.460	<4	Pass
52	5260	A	1.200	4.210	<11	Pass
		B	0.410	3.420	<11	Pass
60	5300	A	2.820	5.830	<11	Pass
		B	2.340	5.350	<11	Pass
64	5320	A	2.950	5.960	<11	Pass
		B	2.110	5.120	<11	Pass
100	5500	A	2.000	5.010	<11	Pass
		B	0.410	3.420	<11	Pass
116	5580	A	2.240	5.250	<11	Pass
		B	1.130	4.140	<11	Pass
140	5700	A	1.650	4.660	<11	Pass
		B	1.720	4.730	<11	Pass

Note 1: The quantity $10 \cdot \log 2$ (two antennas) is added to the spectrum peak value according to document 662911 D01.

Channel 36 – Chain A

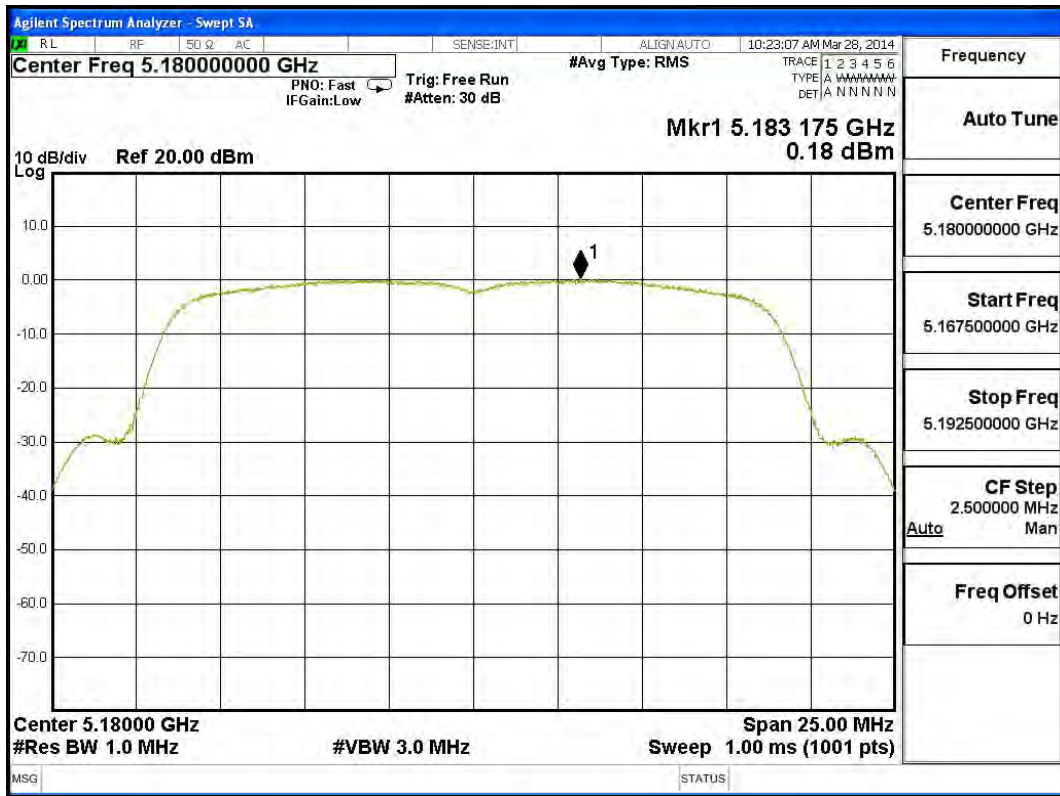

Channel 44 – Chain A

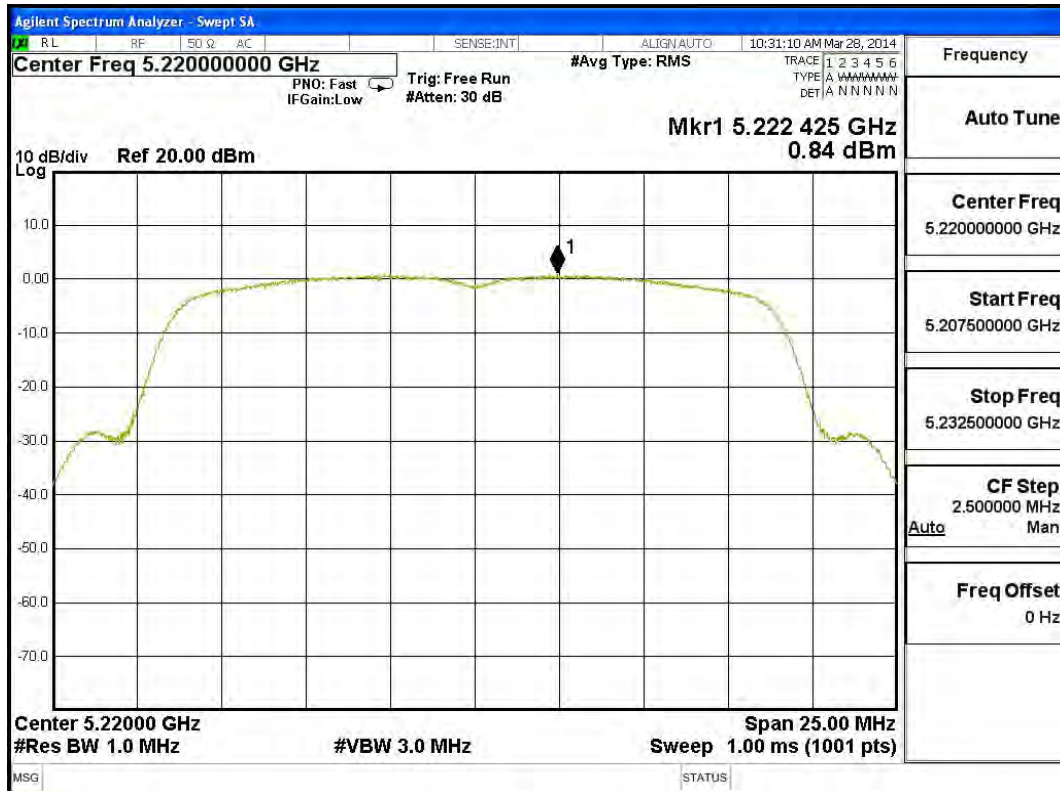

Channel 48 – Chain A

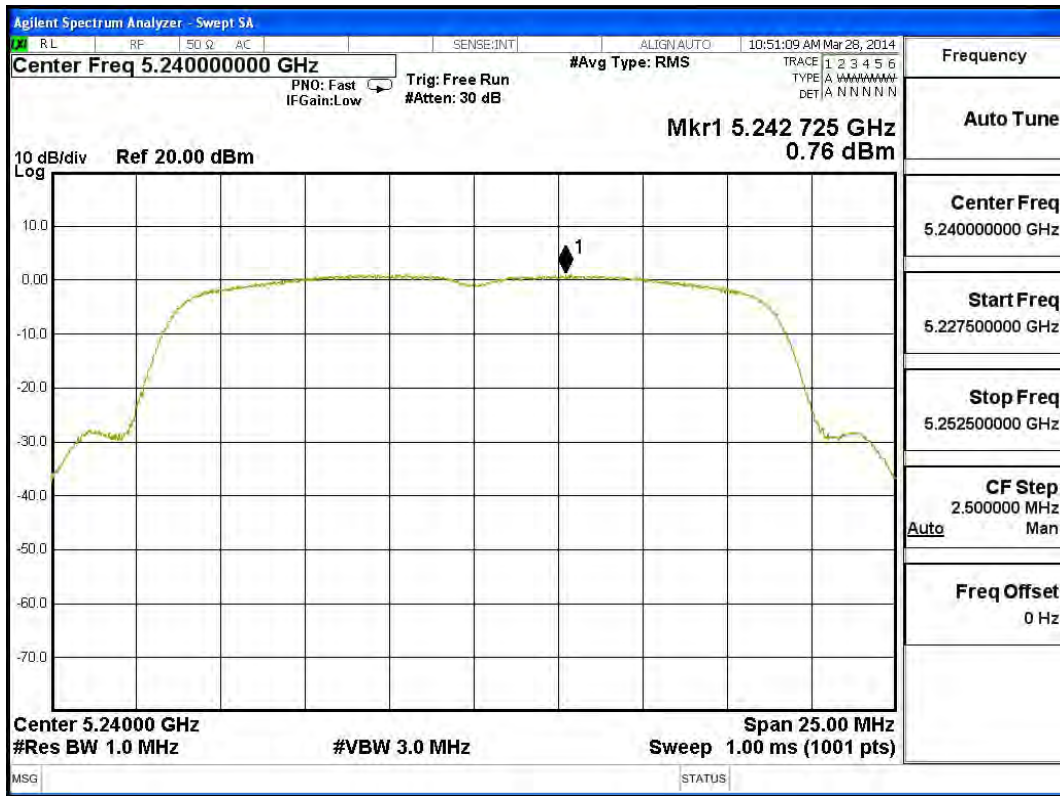

Channel 52 – Chain A

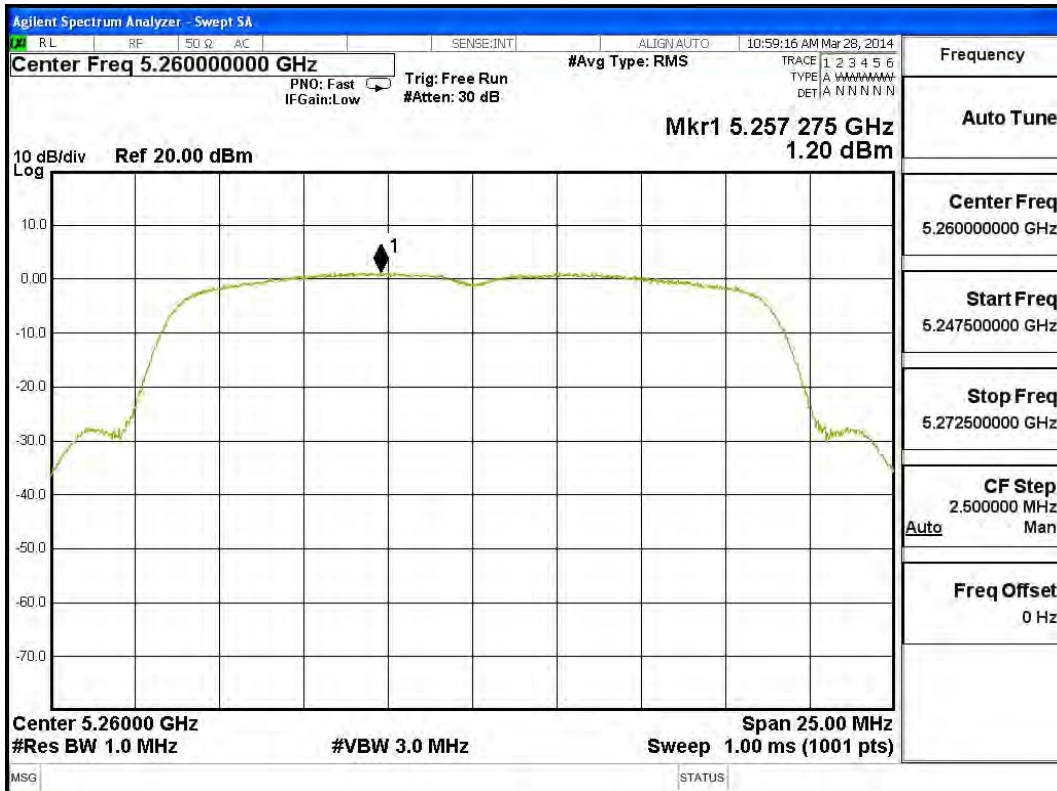

Channel 60 – Chain A

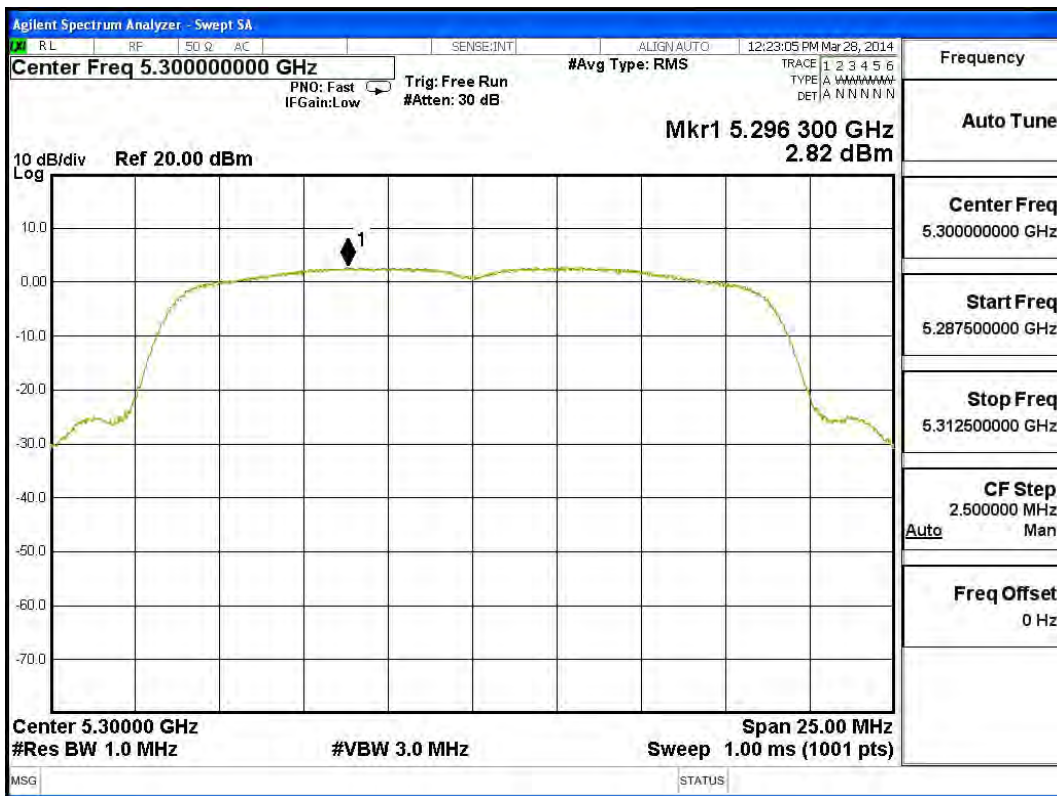

Channel 64 – Chain A

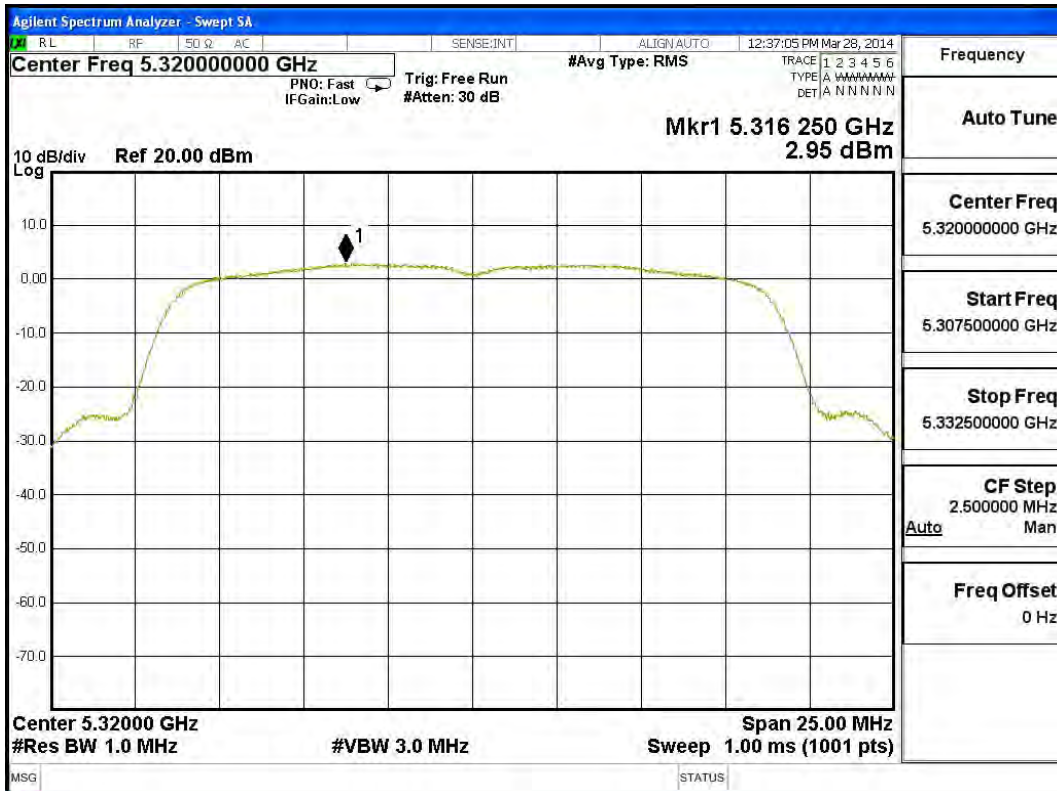

Channel 100 – Chain A

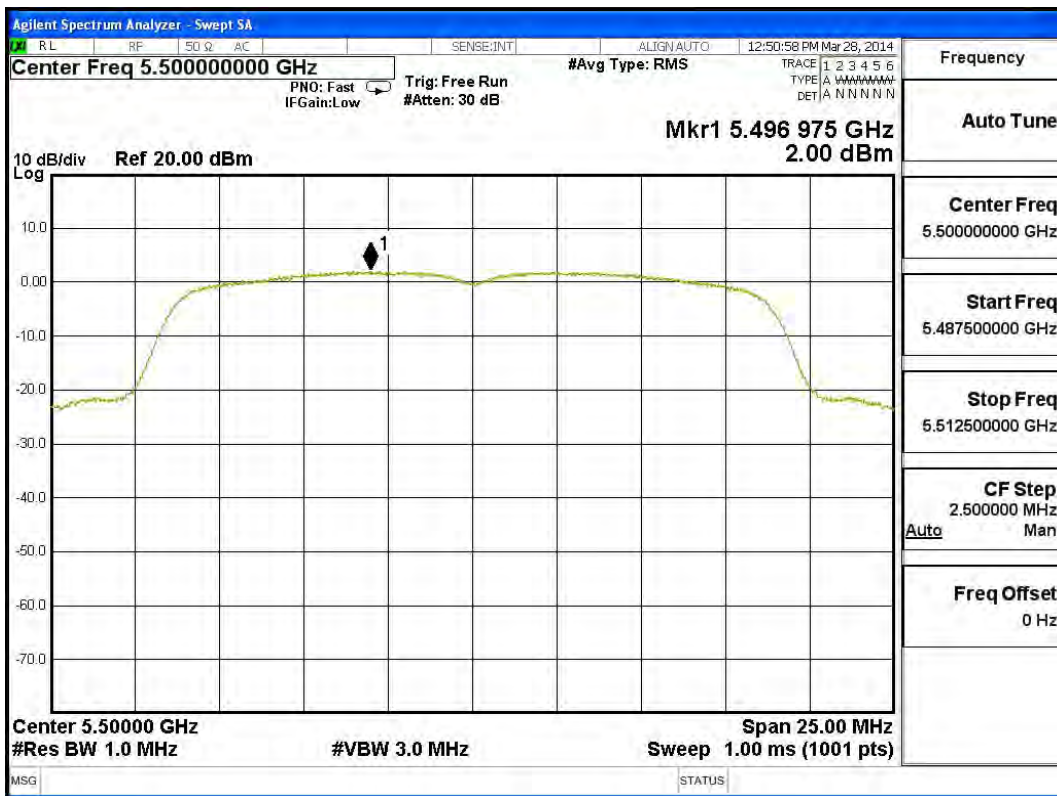

Channel 116 – Chain A

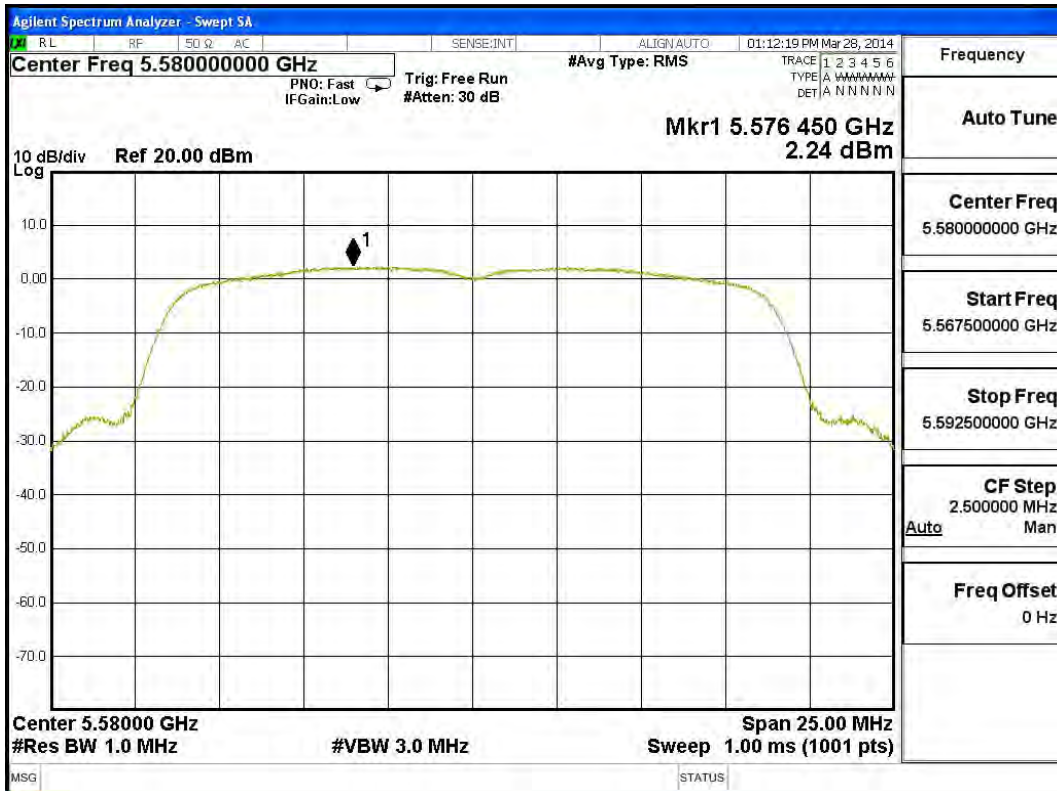

Channel 140 – Chain A

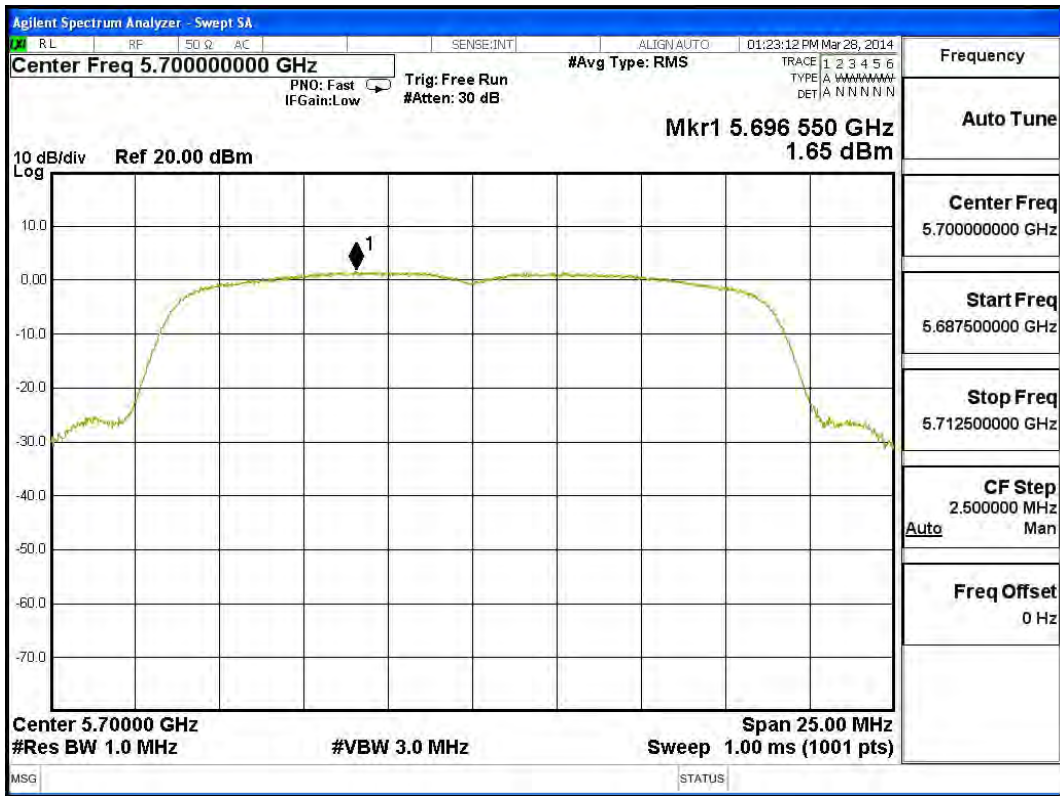

Channel 36 – Chain B

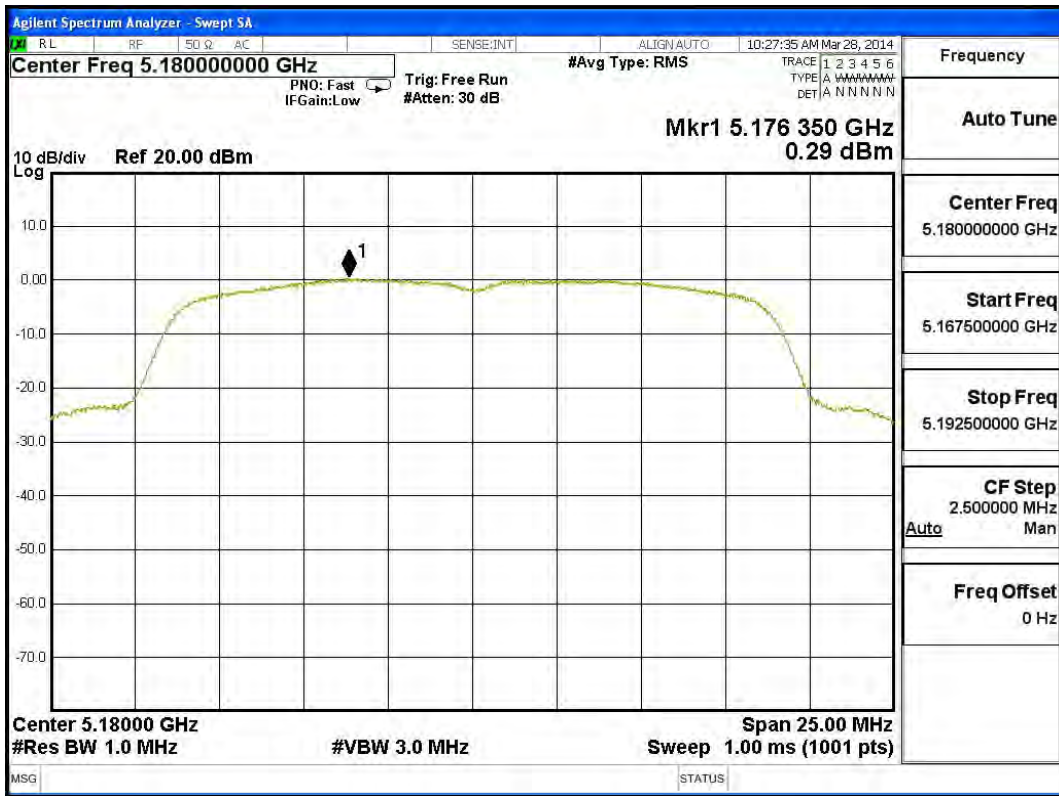

Channel 44 – Chain B

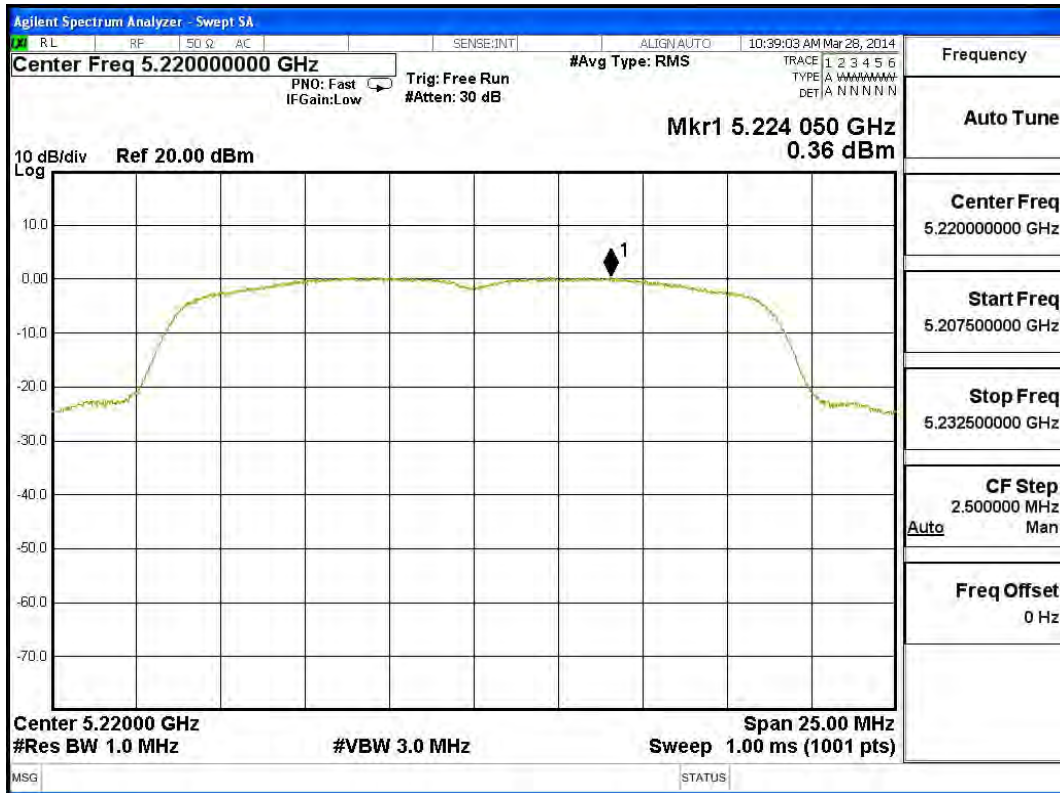

Channel 48 – Chain B

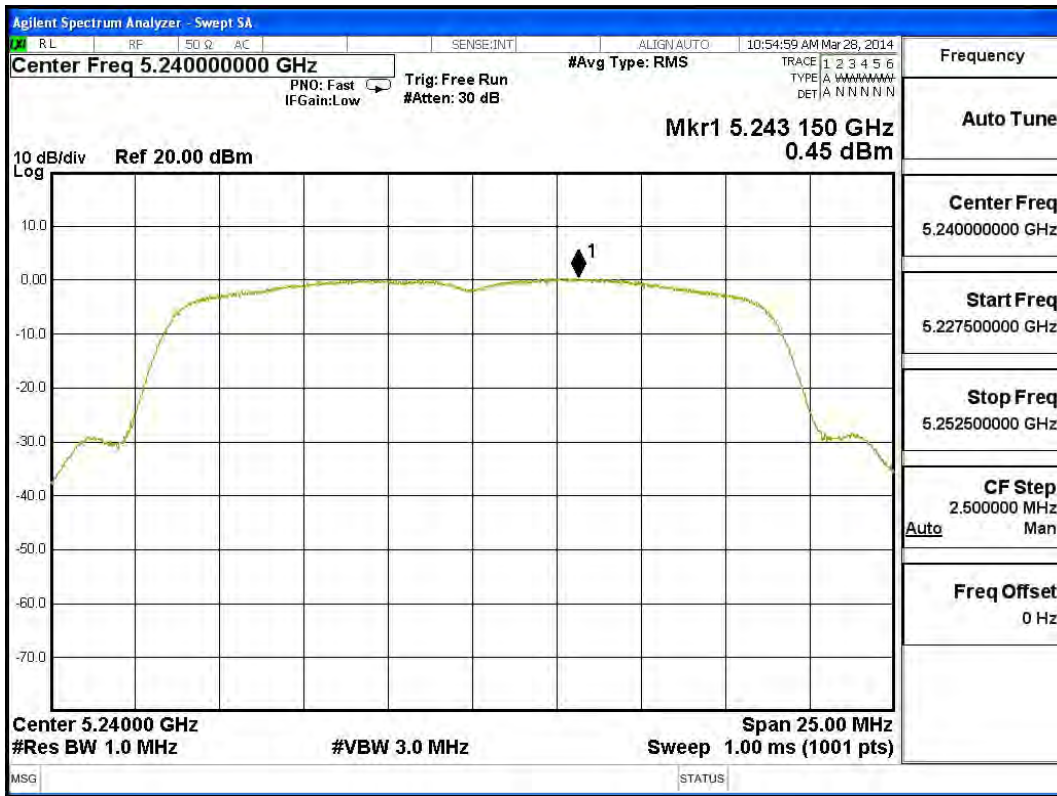

Channel 52 – Chain B

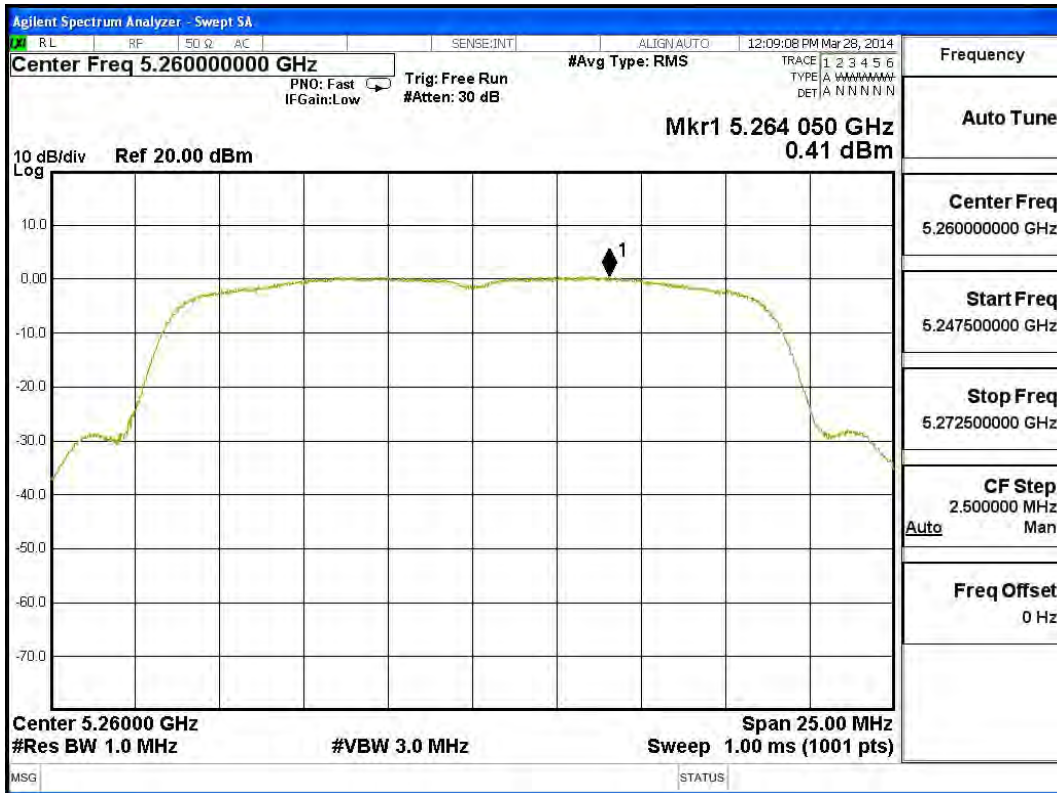

Channel 60 – Chain B

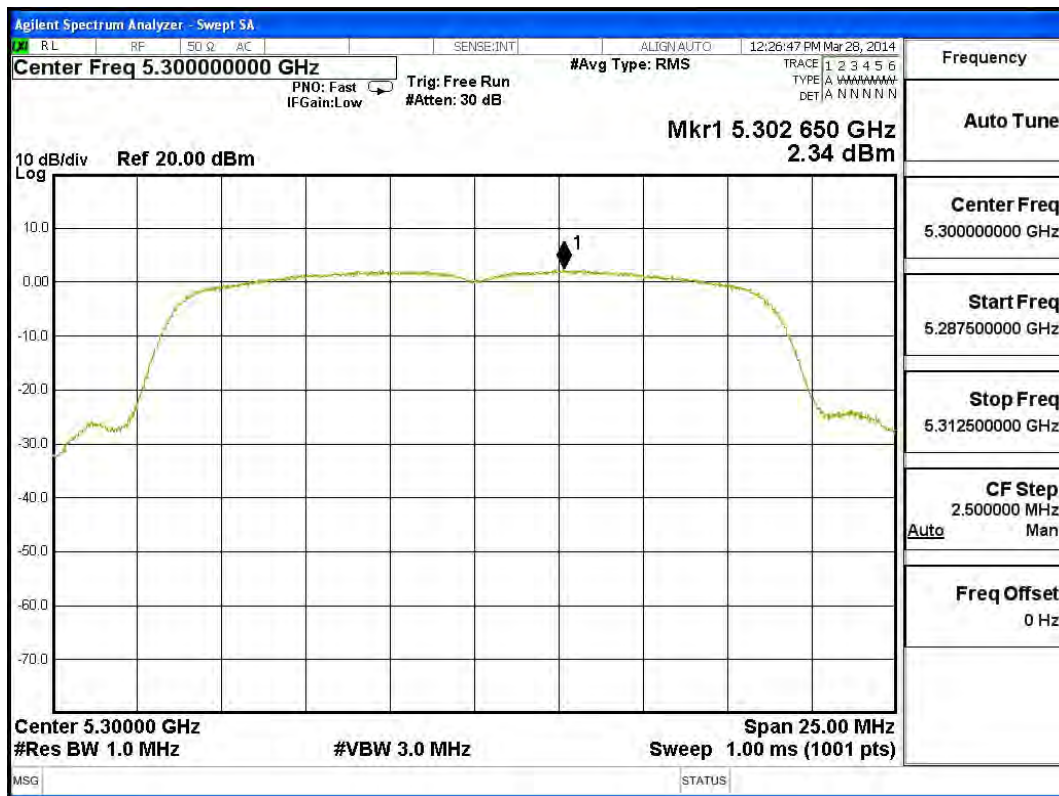

Channel 64 – Chain B

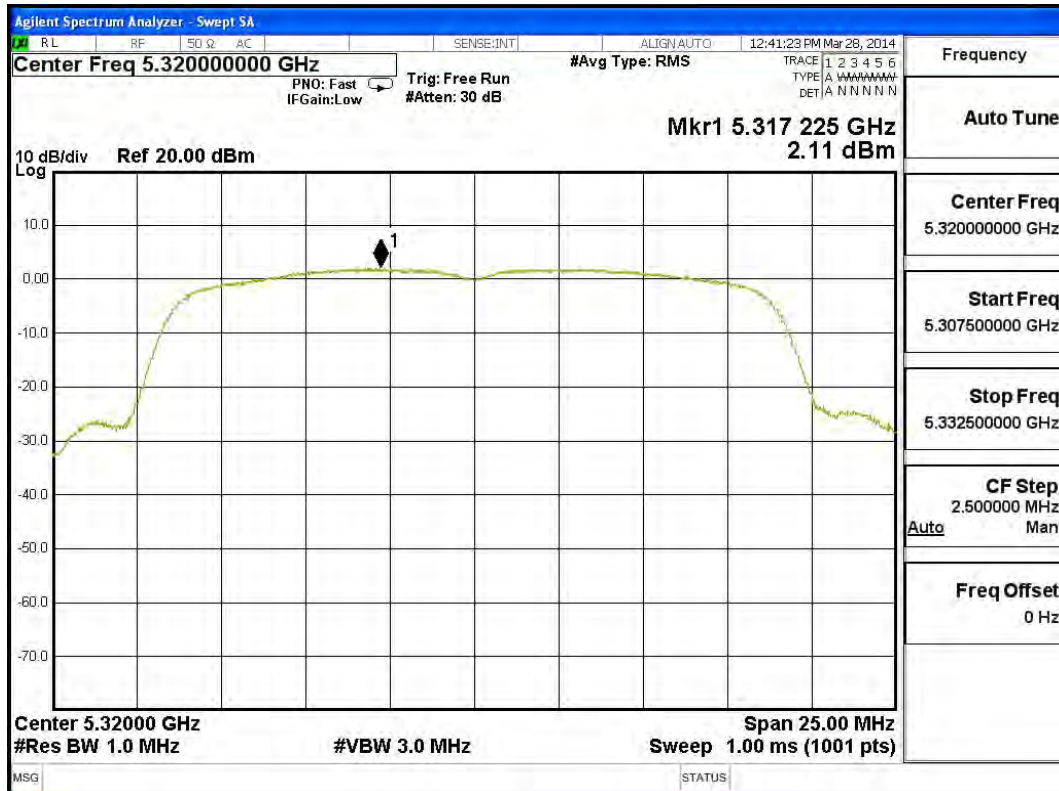

Channel 100 – Chain B

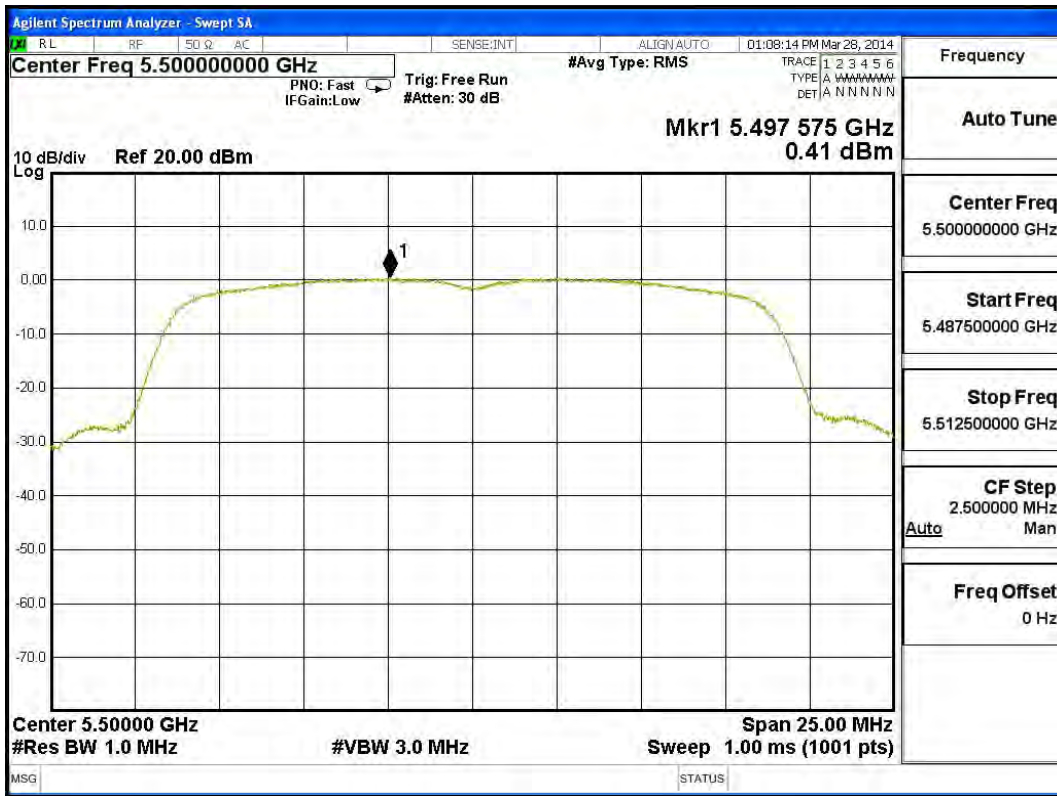

Channel 116 – Chain B

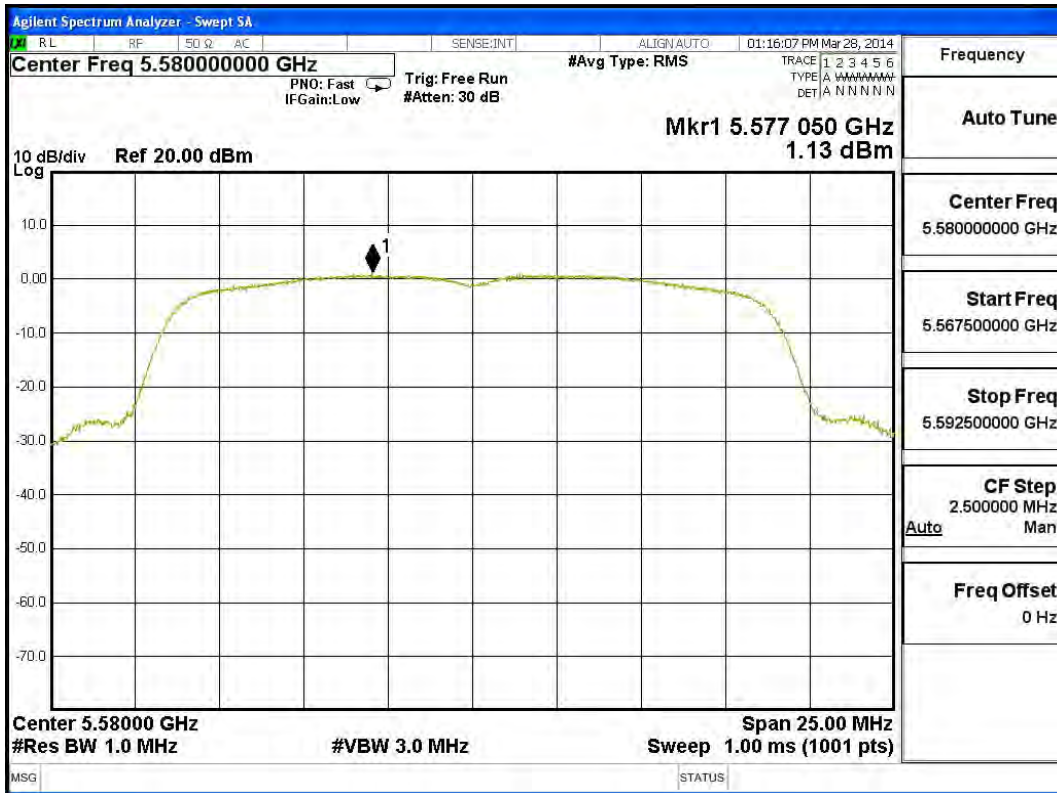

Channel 140 – Chain B

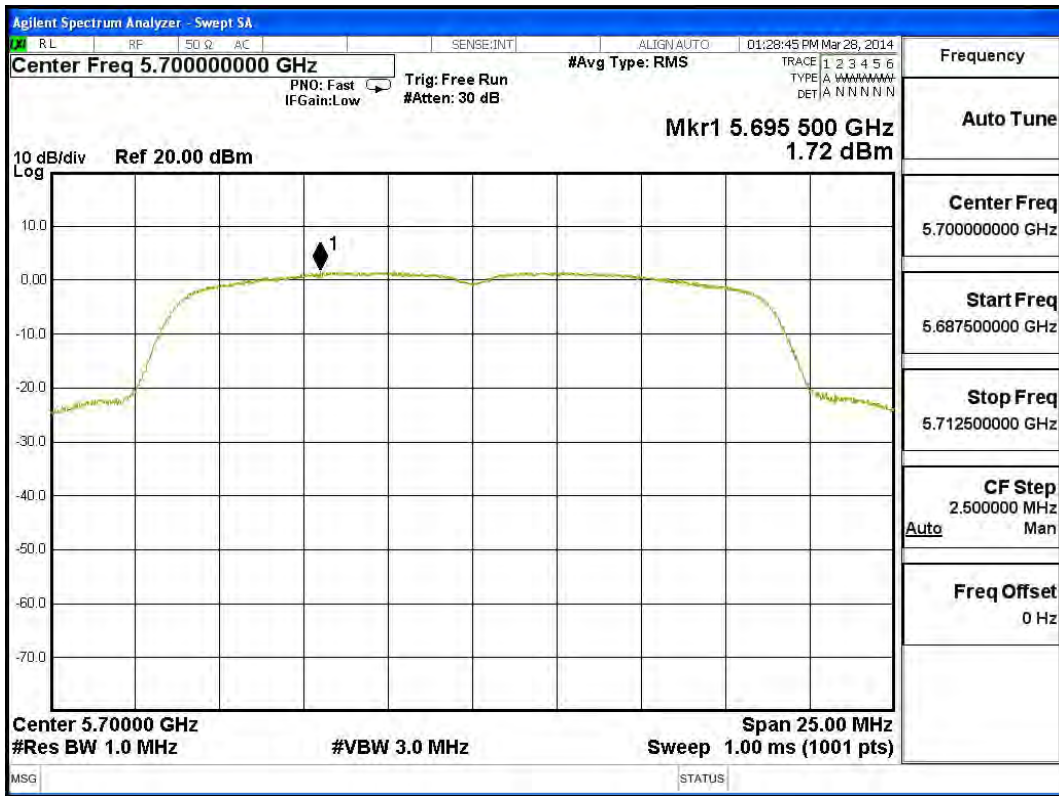

Product : Wireless Motherboard
 Test Item : Peak Power Spectral Density
 Test Site : No.3 OATS
 Test Mode : Mode 3: Transmit (802.11n-40BW 30Mbps)

Channel Number	Frequency (MHz)	Chain	PPSD/MHz (dBm)	Total PPSD/MHz (dBm) ¹	Required Limit (dBm)	Result
38	5190	A	-2.550	0.460	<4	Pass
		B	-2.910	0.100	<4	Pass
46	5230	A	-2.410	0.600	<4	Pass
		B	-2.600	0.410	<4	Pass
54	5270	A	-0.790	2.220	<11	Pass
		B	-1.130	1.880	<11	Pass
62	5310	A	-1.950	1.060	<11	Pass
		B	-3.050	-0.040	<11	Pass
102	5510	A	-2.930	0.080	<11	Pass
		B	-3.920	-0.910	<11	Pass
110	5550	A	-2.930	0.080	<11	Pass
		B	-4.320	-1.310	<11	Pass
134	5670	A	-2.250	0.760	<11	Pass
		B	-2.130	0.880	<11	Pass

Note 1: The quantity $10 \cdot \log 2$ (two antennas) is added to the spectrum peak value according to document 662911 D01.

Channel 38 – Chain A

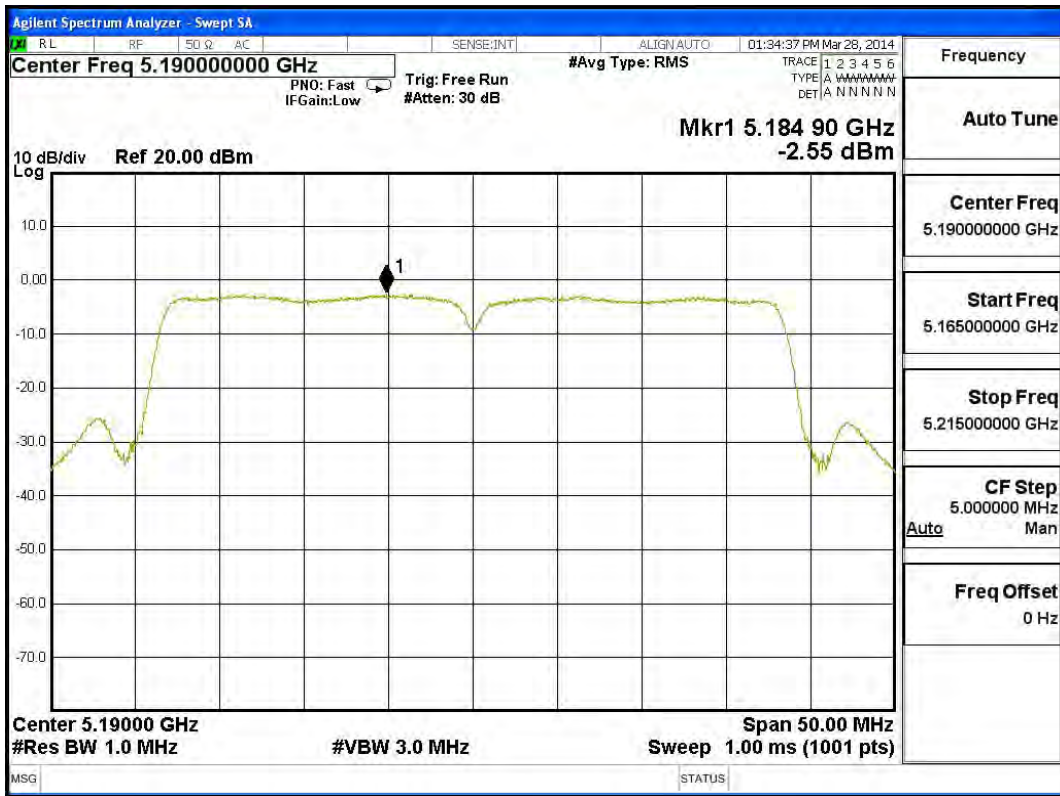

Channel 46 – Chain A

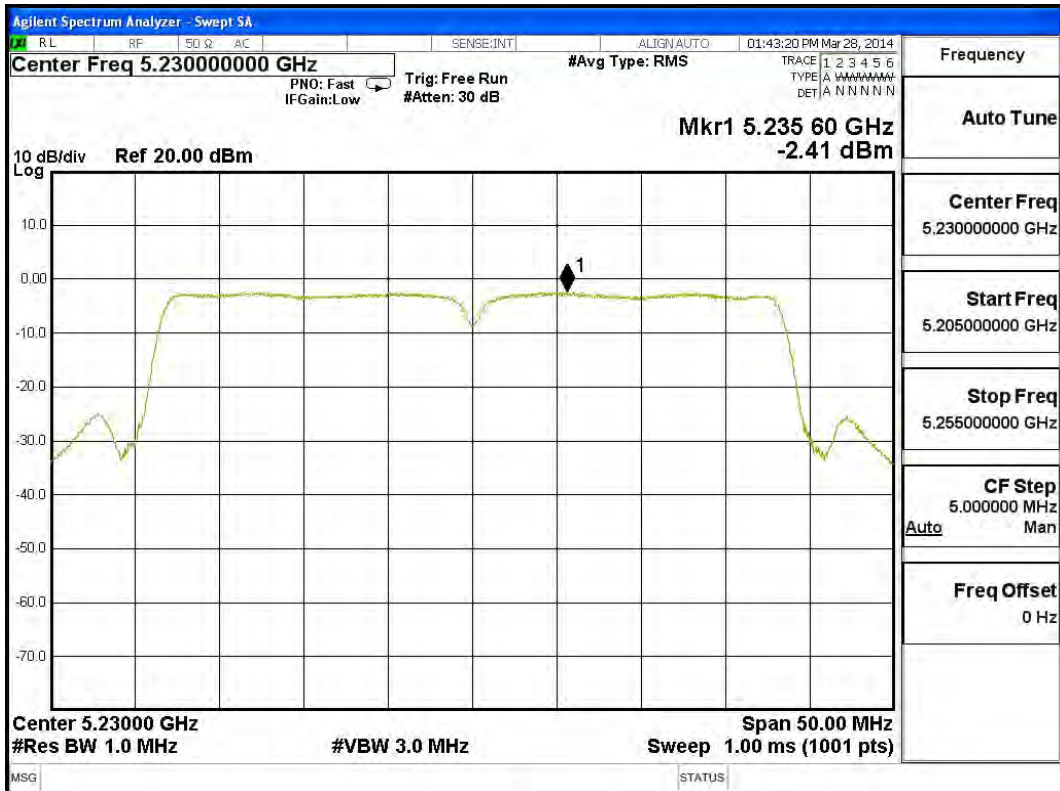

Channel 54 – Chain A

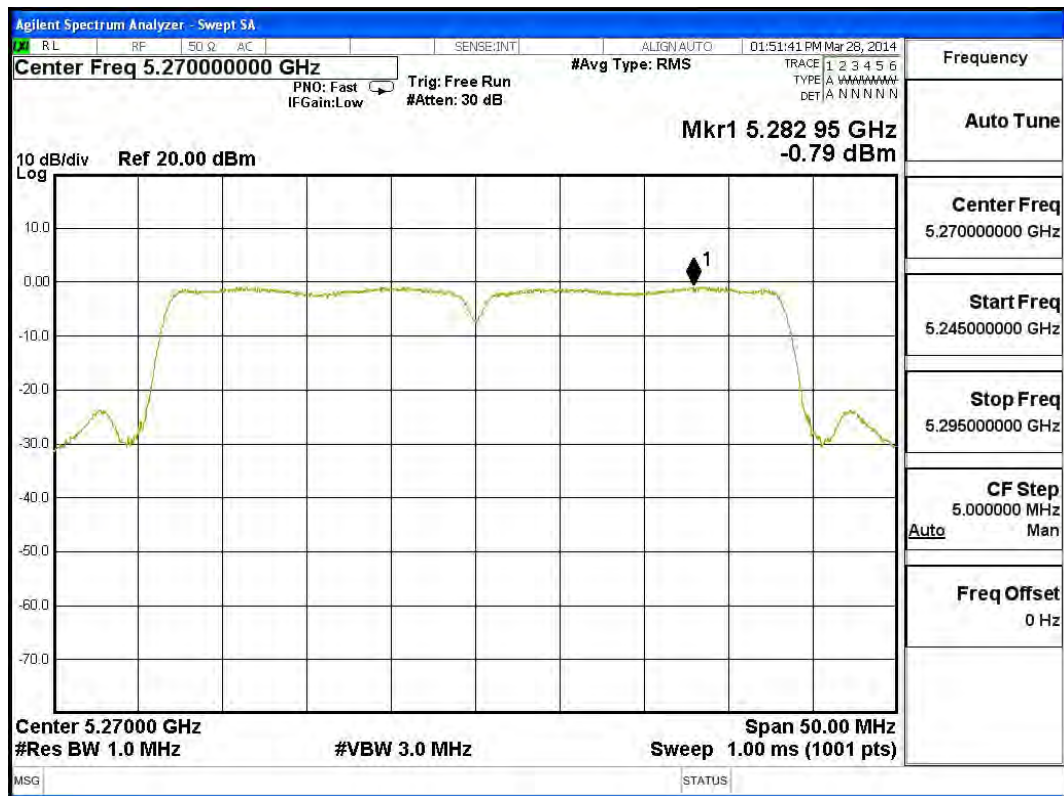

Channel 62 – Chain A

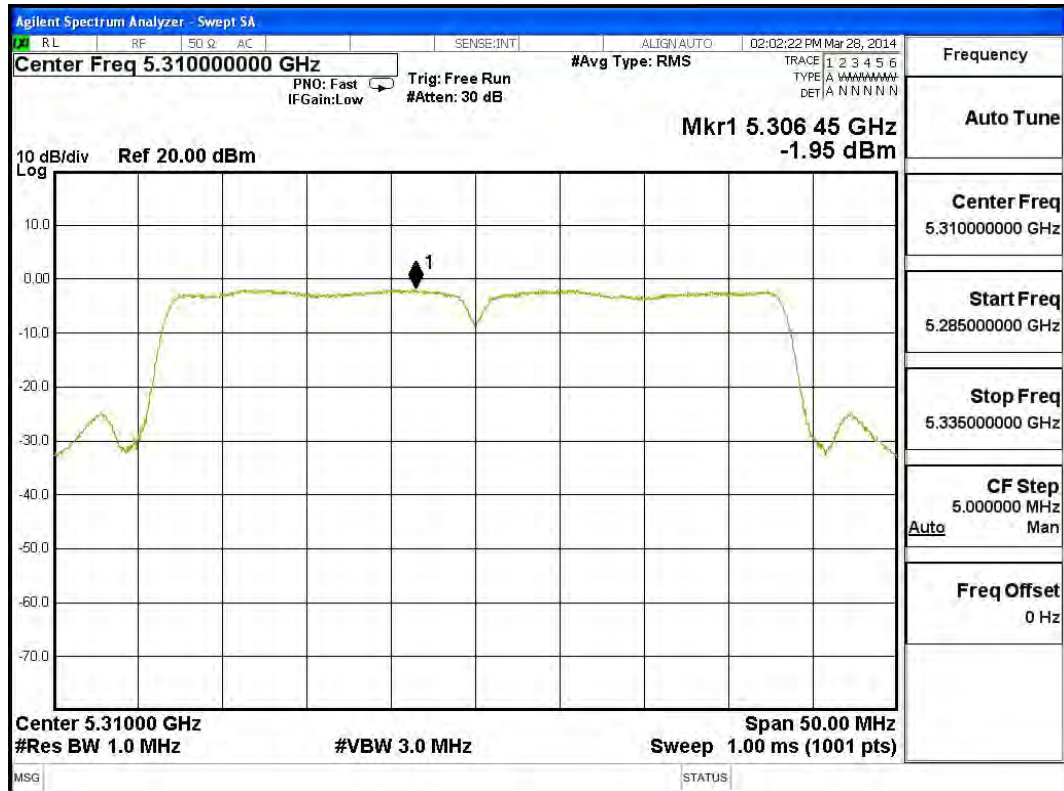

Channel 102 – Chain A

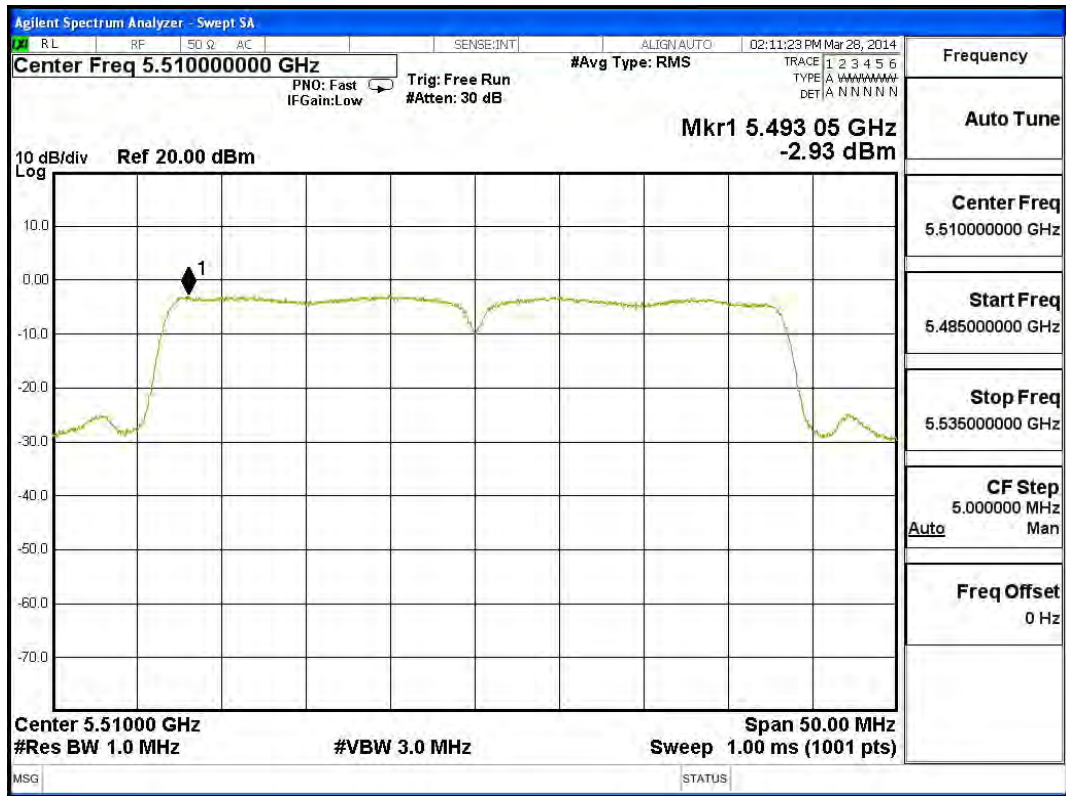

Channel 110 – Chain A

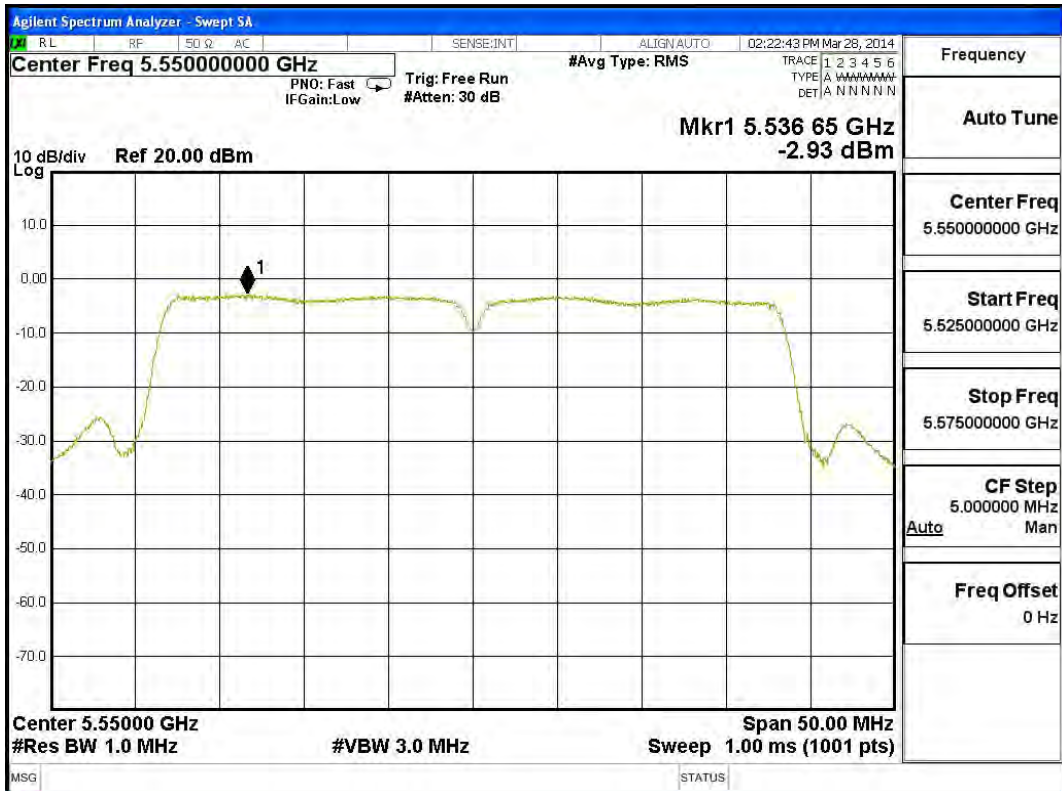

Channel 134 – Chain A

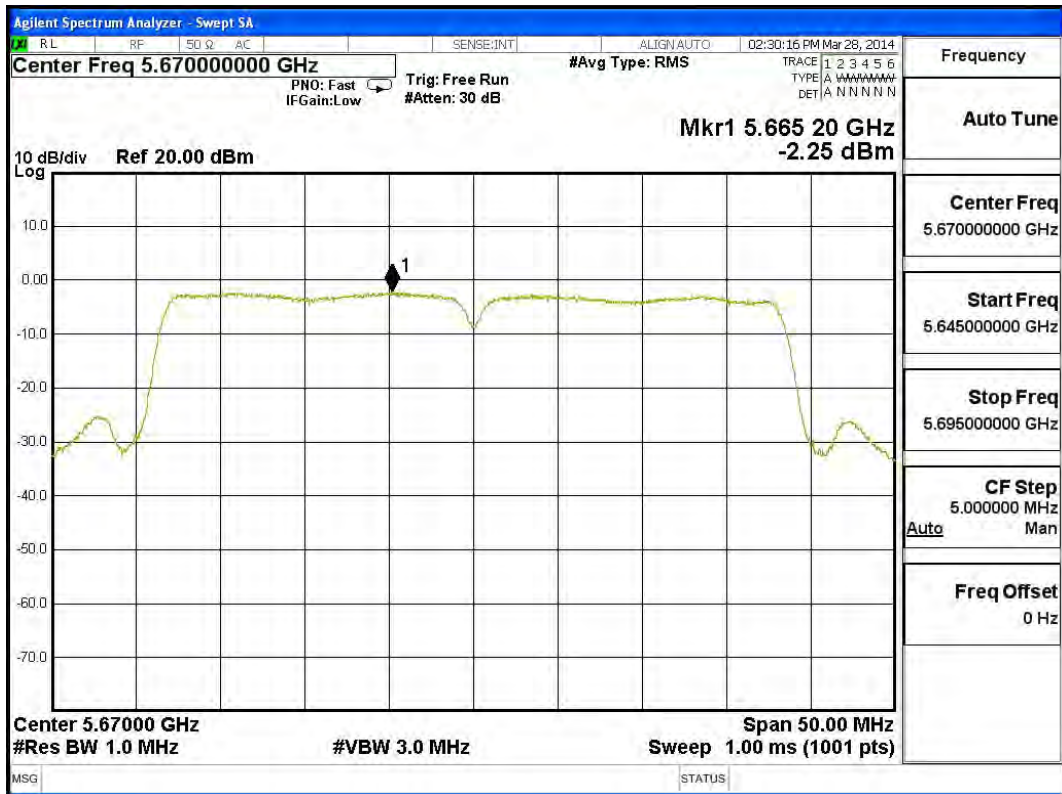

Channel 38 – Chain B

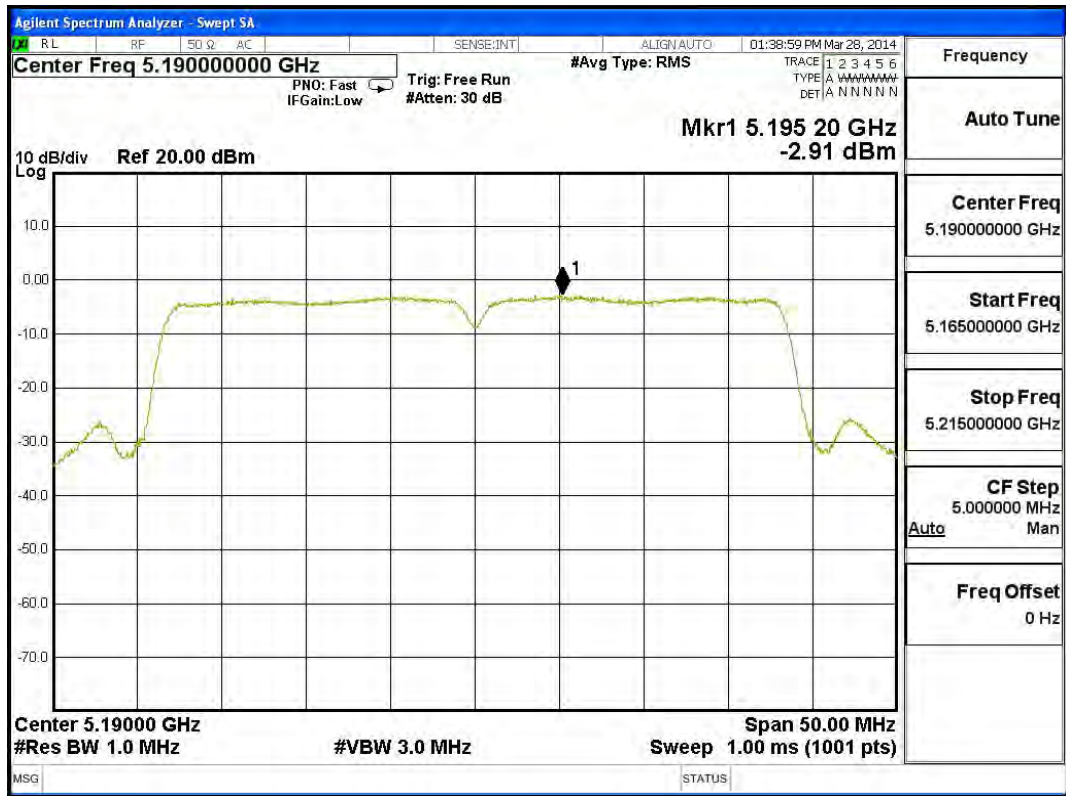

Channel 46 – Chain B

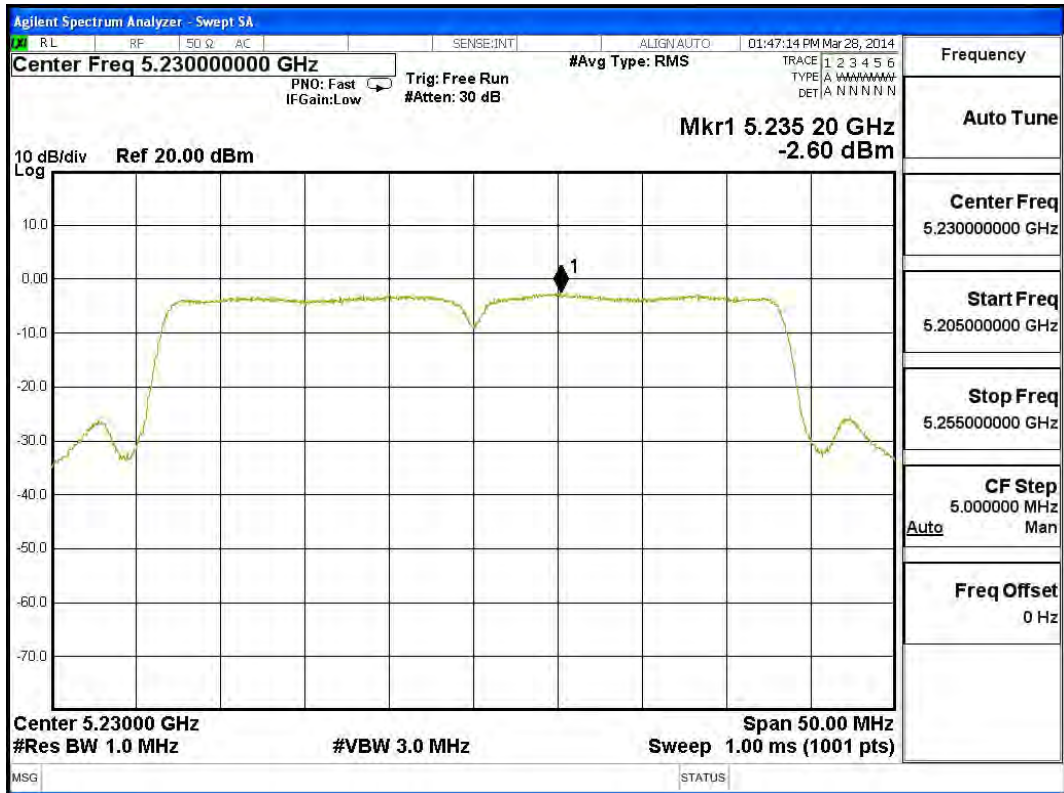

Channel 54 – Chain B

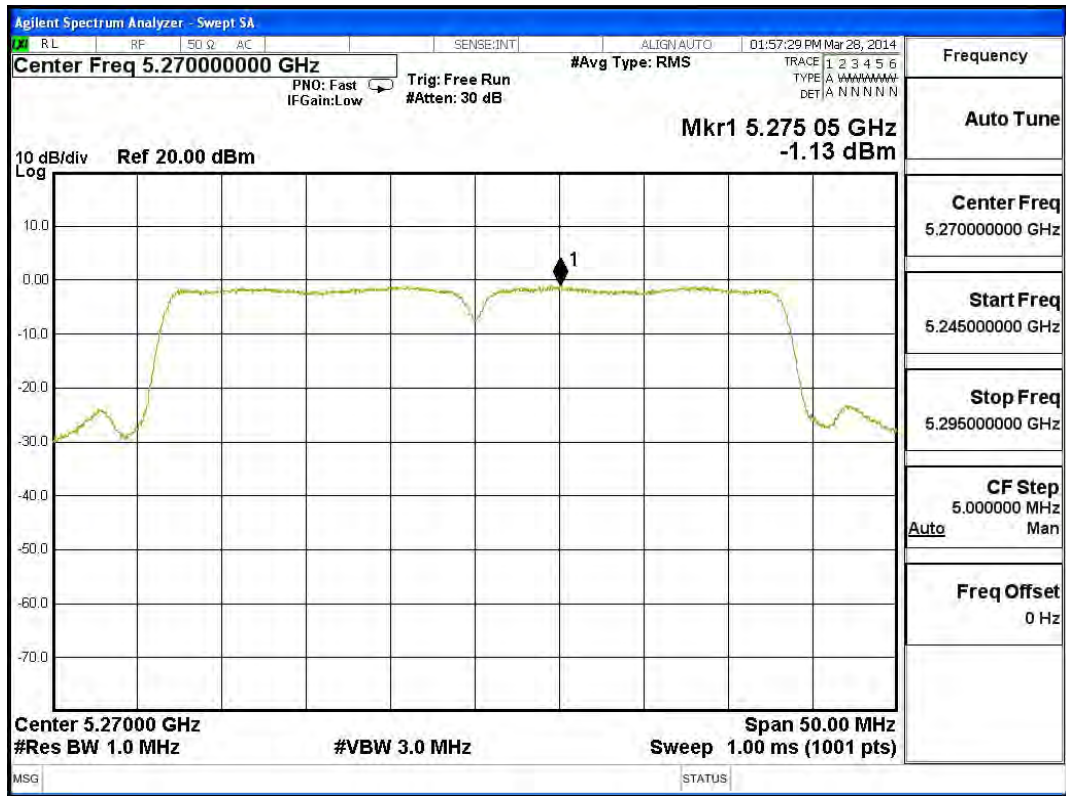

Channel 62 – Chain B

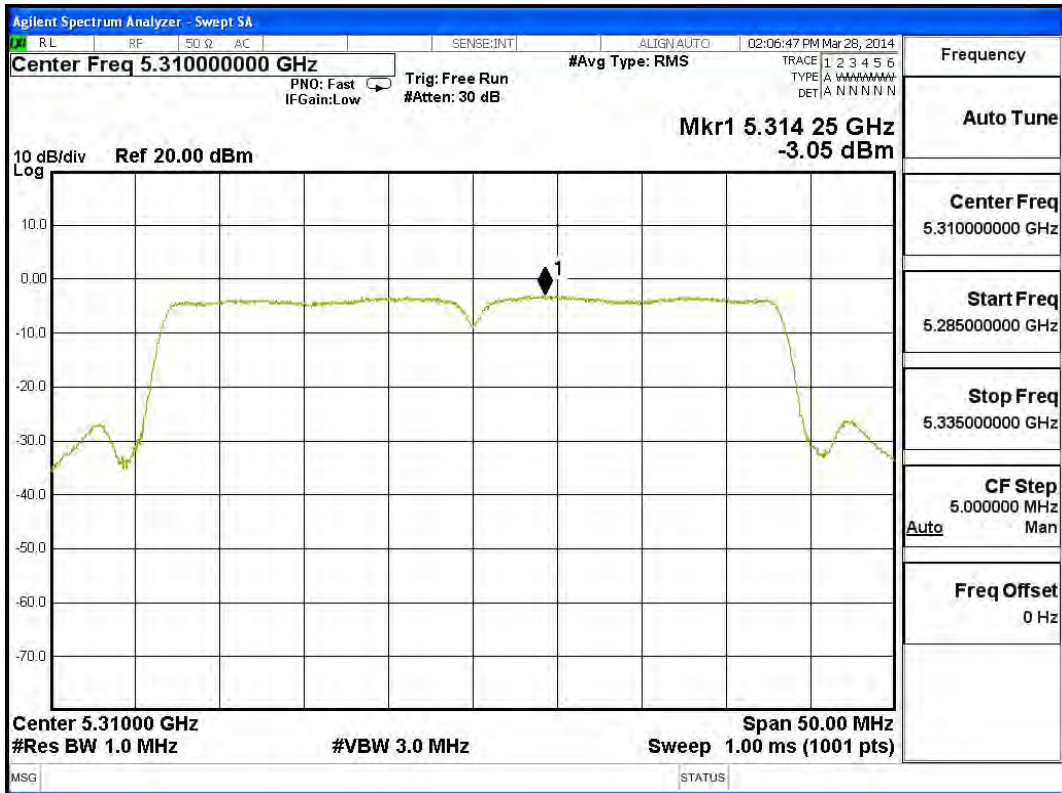

Channel 102 – Chain B

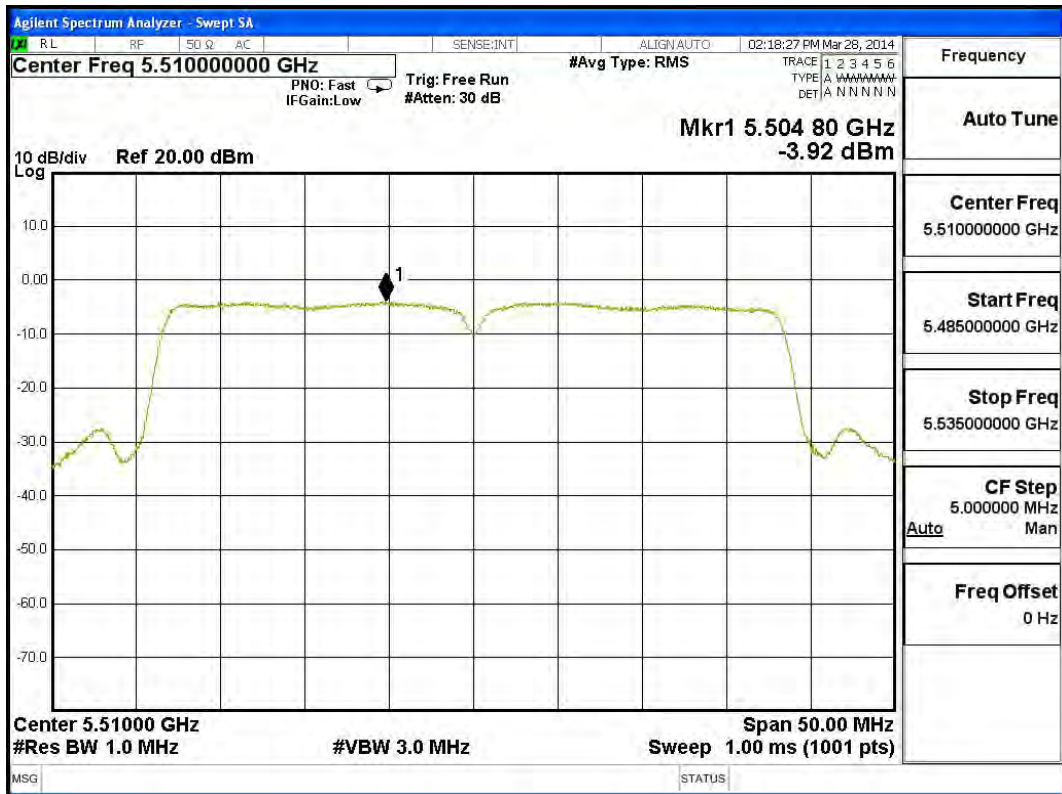

Channel 110 – Chain B

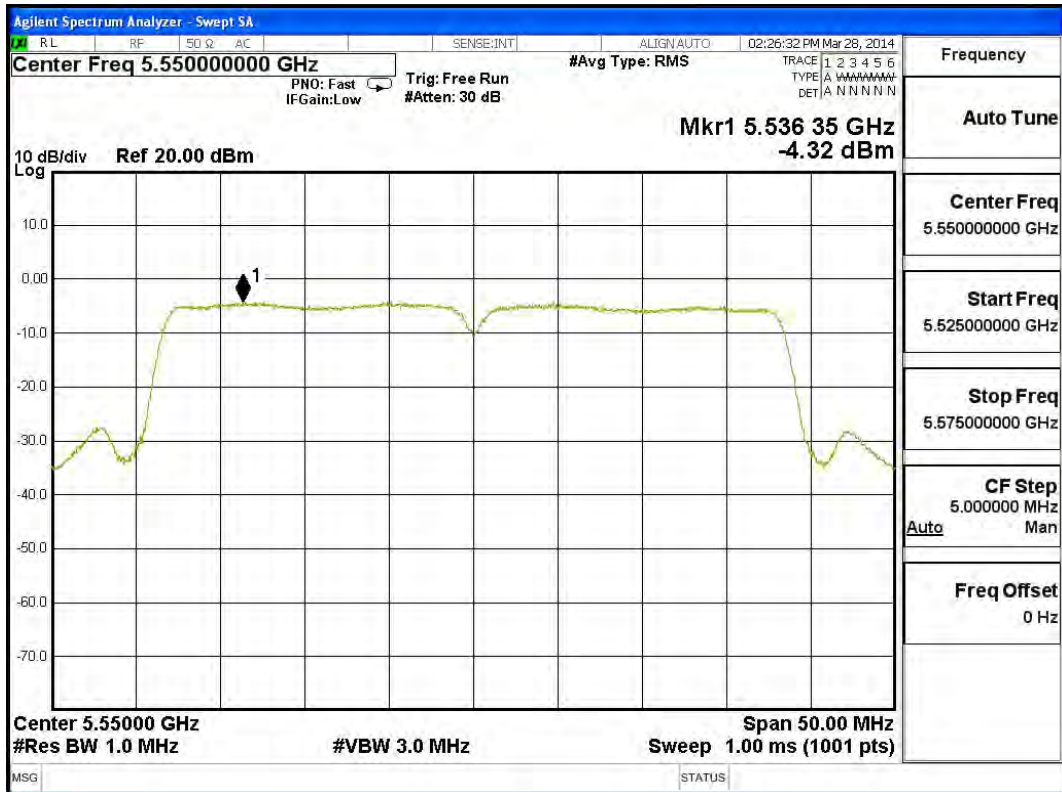

Channel 134 – Chain B

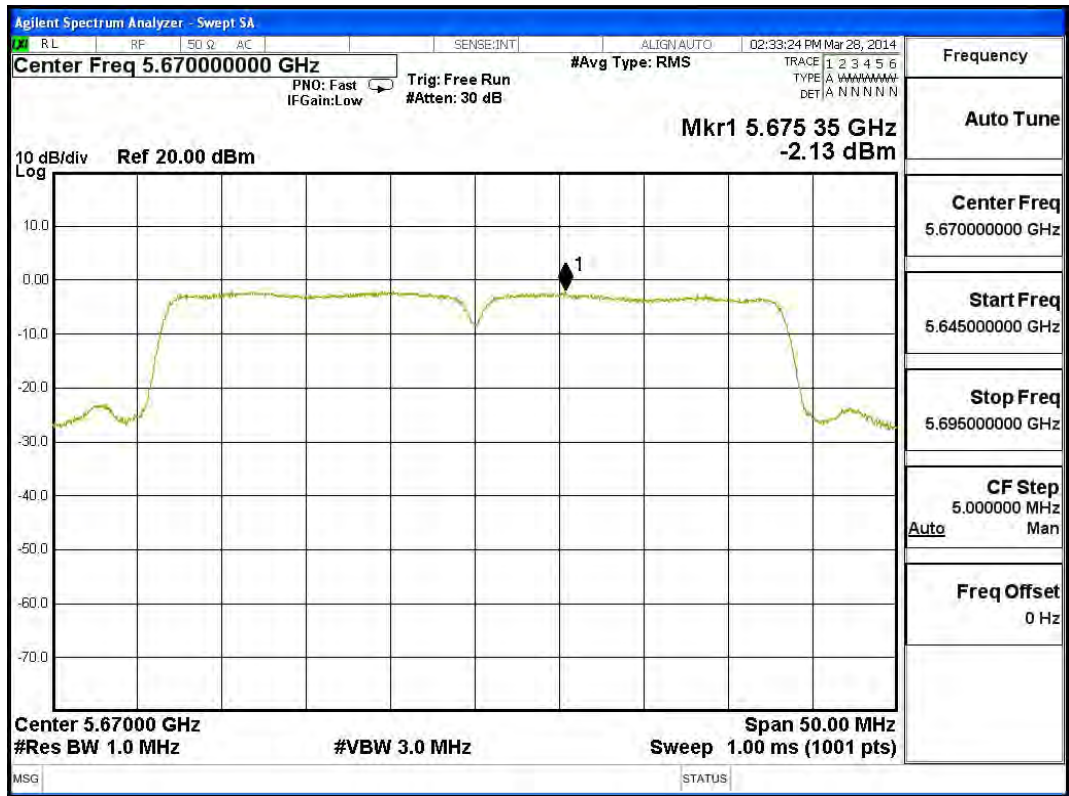

5. Peak Excursion

5.1. Test Equipment

	Equipment	Manufacturer	Model No./Serial No.	Last Cal.
	Spectrum Analyzer	R&S	FSP40 / 100170	Jun, 2013
	Spectrum Analyzer	Agilent	E4407B / US39440758	Jun, 2013
X	Spectrum Analyzer	Agilent	N9010A / MY48030495	Apr., 2014

Note:

1. All equipments are calibrated with traceable calibrations. Each calibration is traceable to the national or international standards.
2. The test instruments marked with “X” are used to measure the final test results.

5.2. Test Setup

Conduction Power Measurement

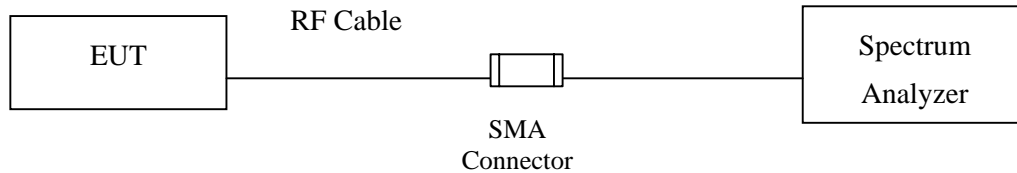

5.3. Limits

The ratio of the peak excursion of the modulation envelope (measured using a peak hold function) to the peak transmit power (measured as specified above) shall not exceed 13 dB across any 1 MHz bandwidth or the emission bandwidth whichever is less.

5.4. Test Procedure

The EUT was setup to ANSI C63.10, 2009; tested to DTS test procedure of FCC KDB-789033 for compliance to FCC 47CFR Subpart E requirements.

Step 1: Set the spectrum analyzer or EMI receiver span to view the entire emission bandwidth.

Step 2: Find the maximum of the peak-max-hold spectrum.

(Set RBW = 1 MHz, VBW \geq 3 MHz, Detector = peak, Trace mode = max-hold, Allow the sweeps to continue until the trace stabilizes, Use the peak search function to find the peak of the spectrum.)

Step 3: Use the procedure found under KDB-789033 F) to measure the PPSD.

Step 4: Compute the ratio of the maximum of the peak-max-hold spectrum to the PPSD.

5.5. Uncertainty

± 1.27 dB

5.6. Test Result of Peak Excursion

Product : Wireless Motherboard
 Test Item : Peak Excursion
 Test Site : No.3 OATS
 Test Mode : Mode 1: Transmit (802.11a-6Mbps)

Channel No.	Frequency (MHz)	Data Rate (Mbps)	Measurement Level (dB)	Required Limit (dB)	Result
100	5500	6	8.580	<13	Pass
		12	8.170	<13	Pass
		24	8.550	<13	Pass
		54	8.290	<13	Pass

Channel 100:

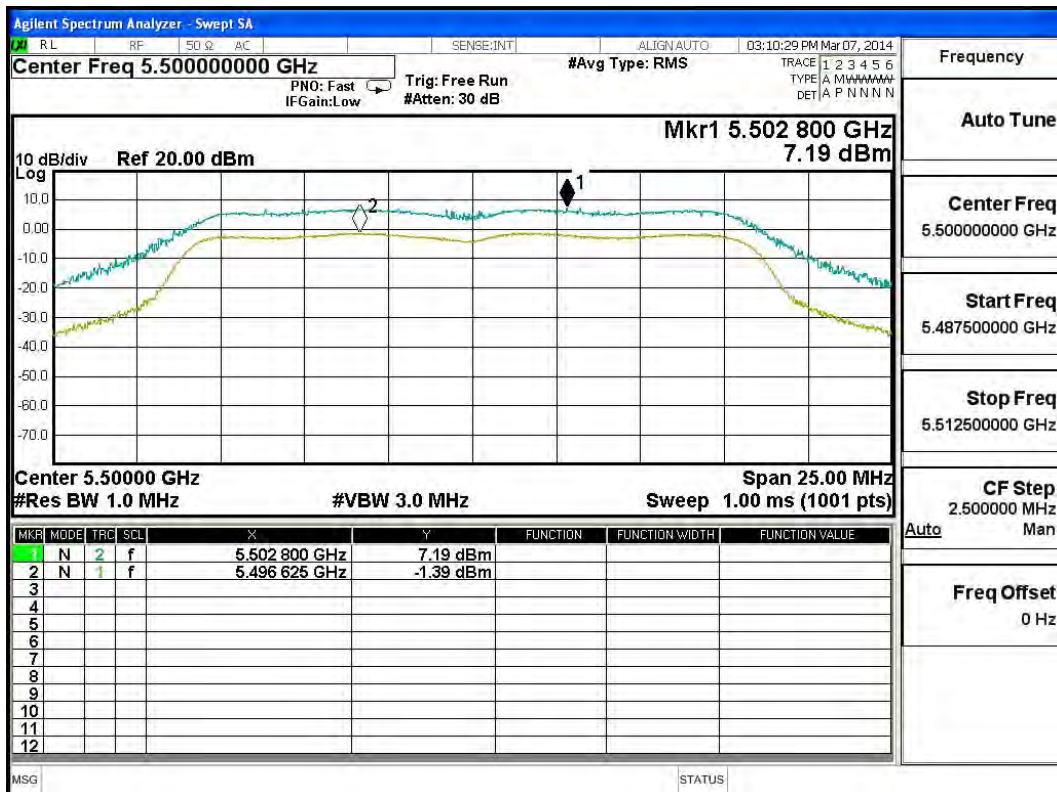

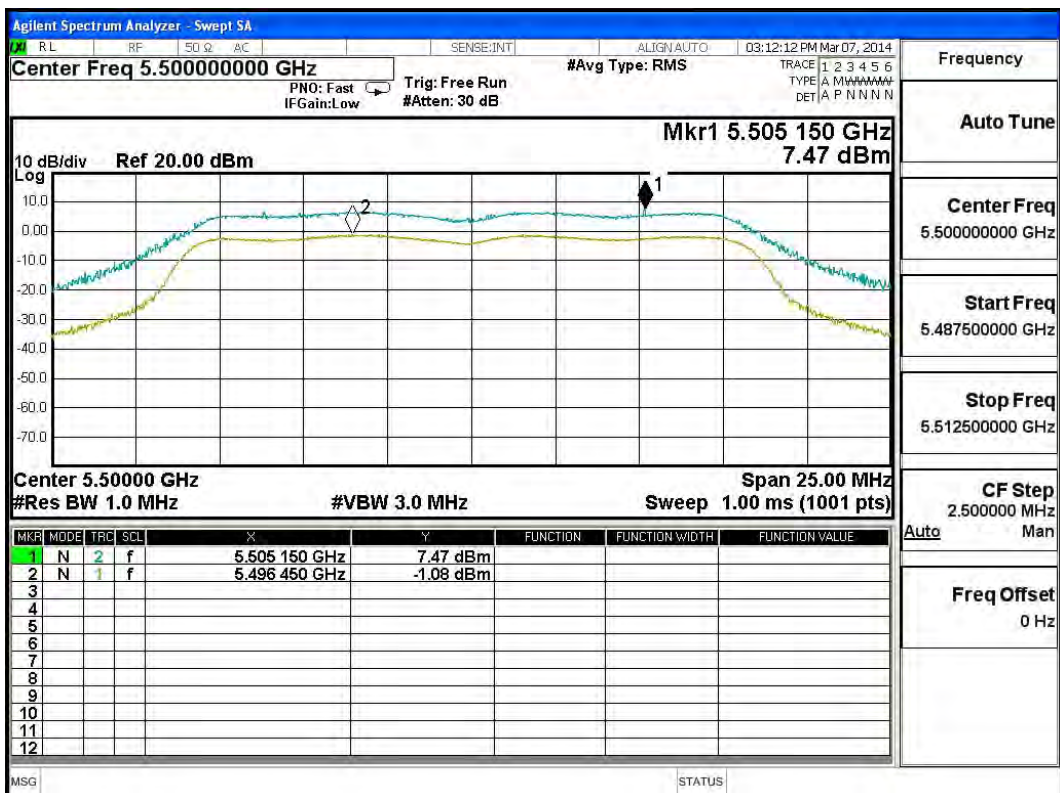
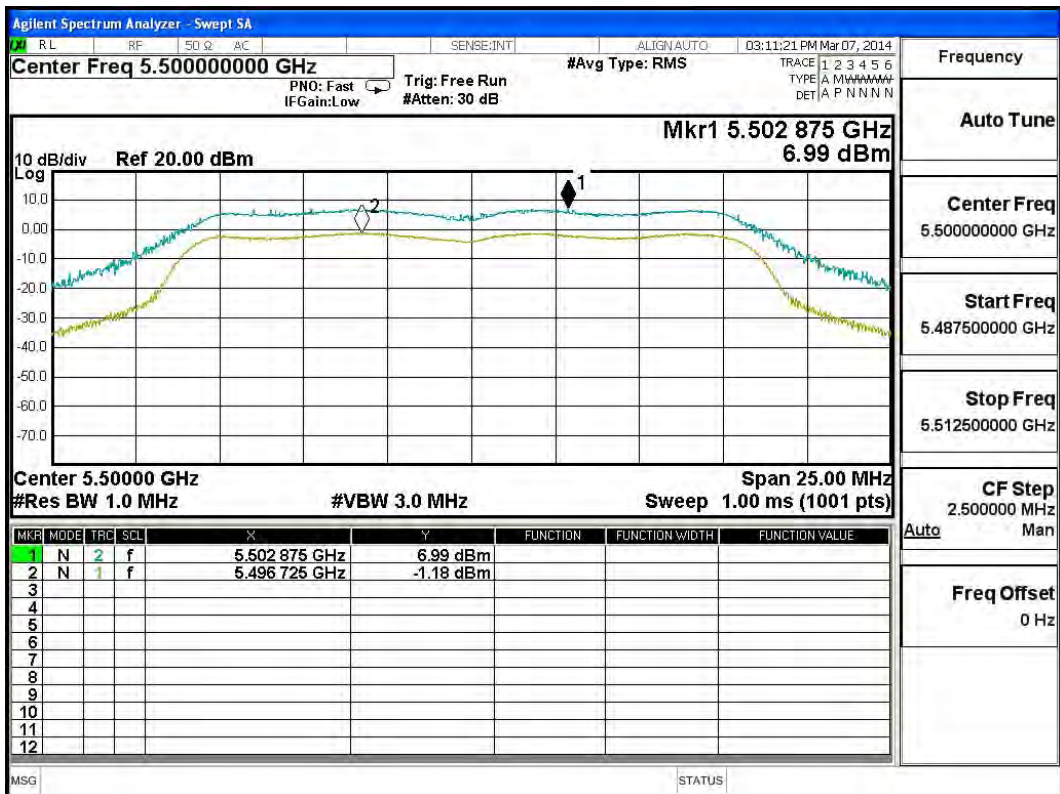

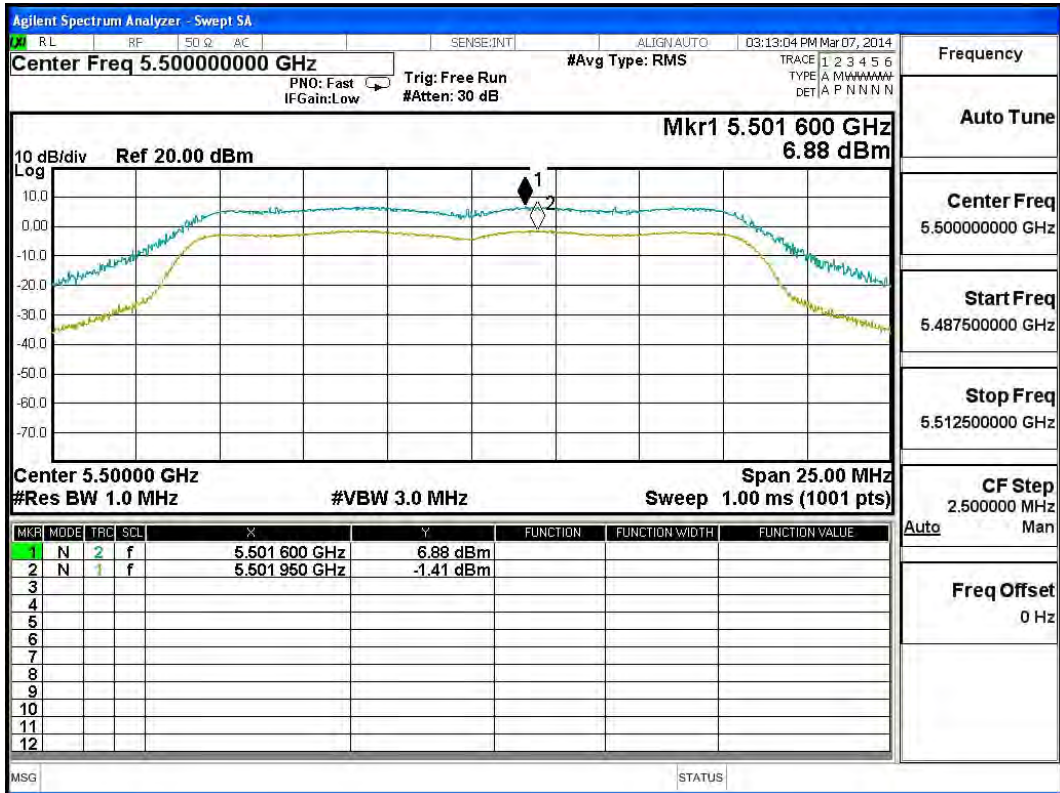

Product : Wireless Motherboard
 Test Item : Peak Excursion
 Test Site : No.3 OATS
 Test Mode : Mode 2: Transmit (802.11n-20BW 14.4Mbps)

Chain A

Channel No.	Frequency (MHz)	Data Rate (Mbps)	Measurement Level (dB)	Required Limit (dB)	Result
100	5500	MCS (8)	9.450	<13	Pass
		MCS (10)	9.670	<13	Pass
		MCS (12)	9.670	<13	Pass
		MCS (15)	9.140	<13	Pass

Channel 100:

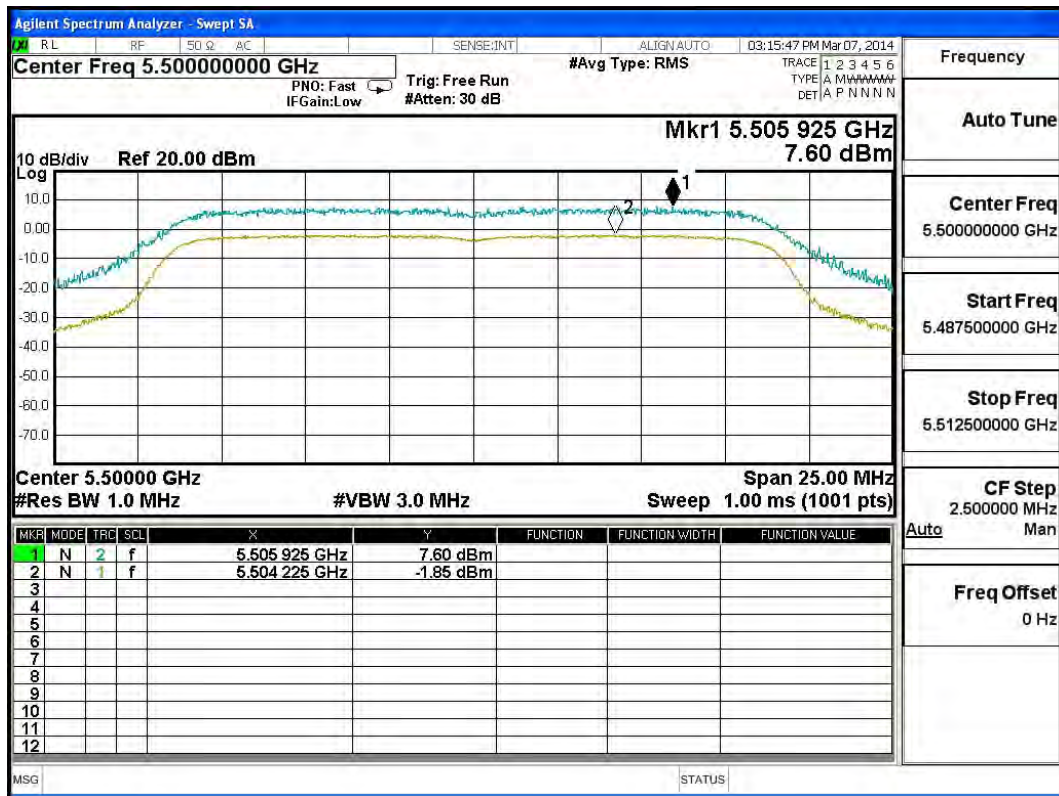

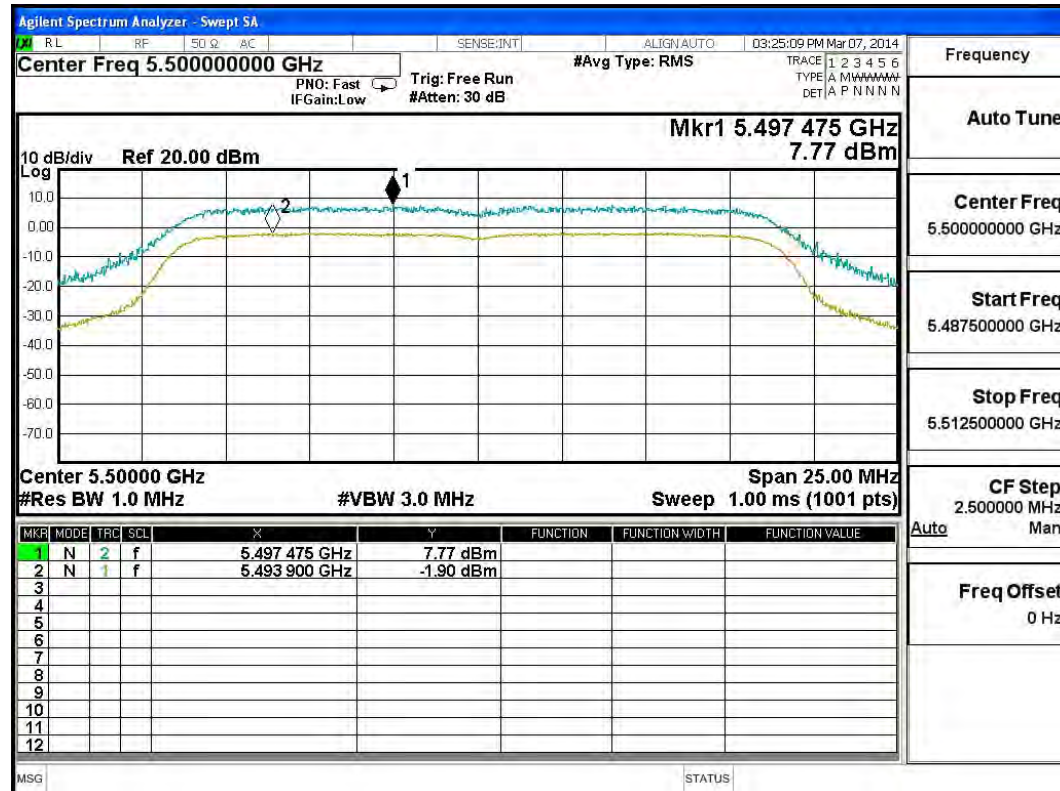
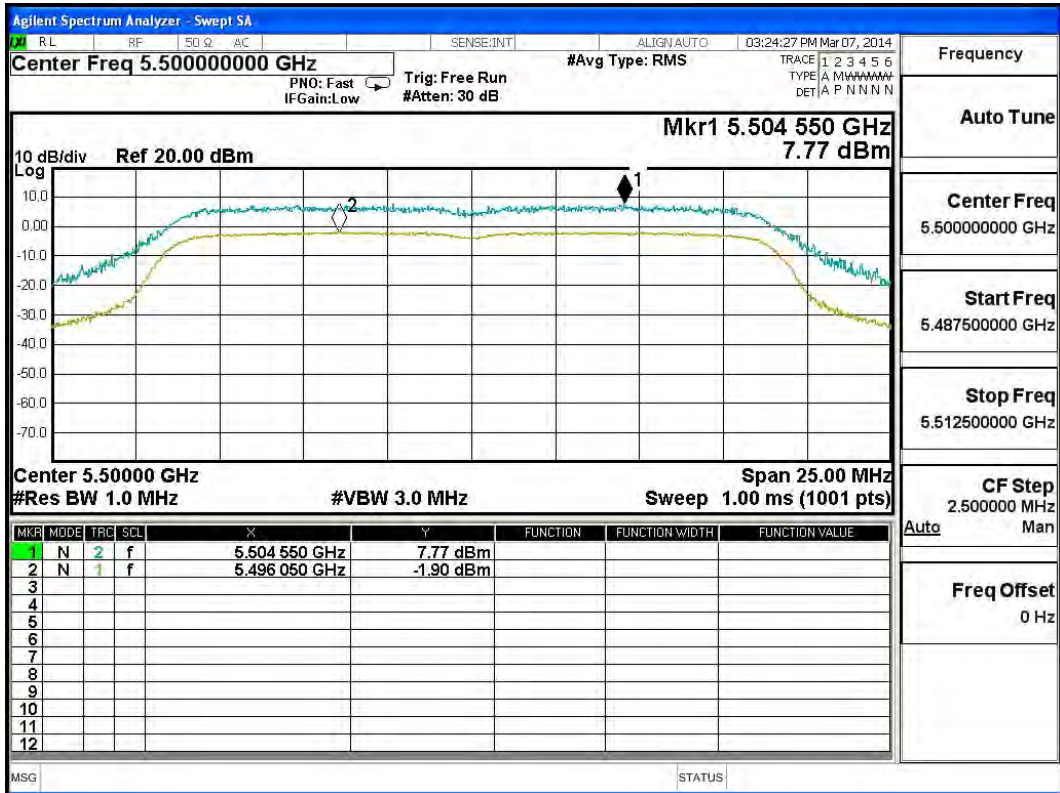

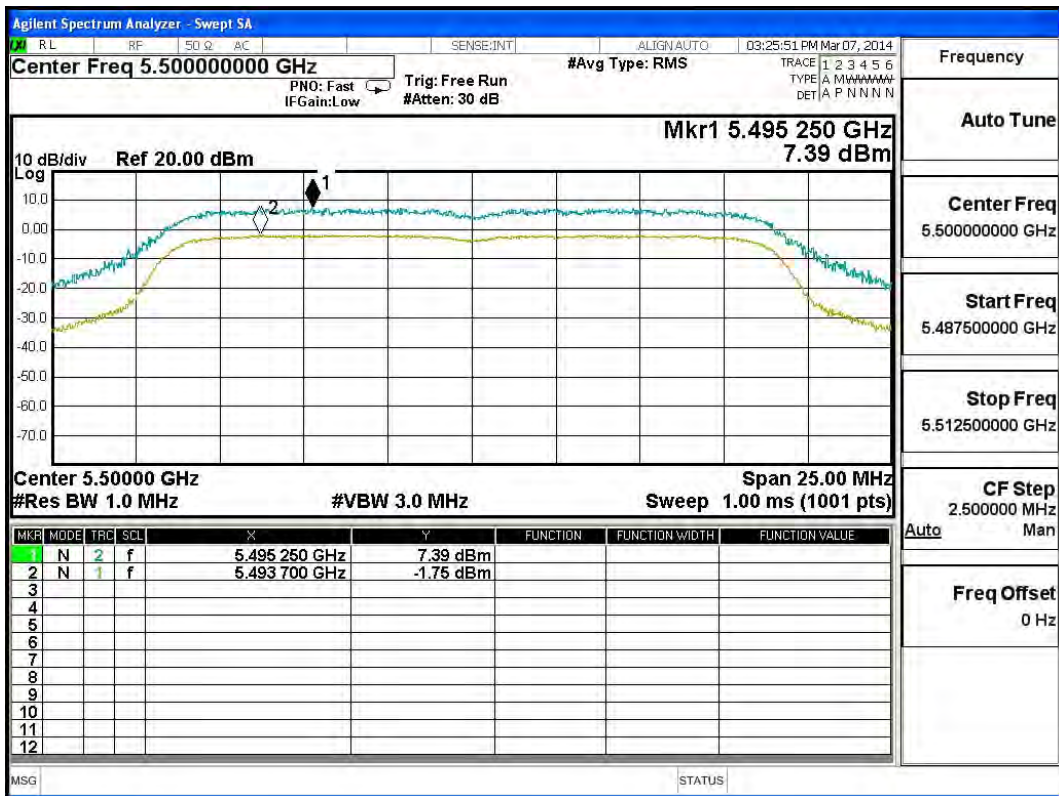

Frequency	
Auto Tune	
Center Freq	5.500000000 GHz
Start Freq	5.487500000 GHz
Stop Freq	5.512500000 GHz
CF Step	2.500000 MHz
Auto	Man
Freq Offset	0 Hz

Chain B

Channel No.	Frequency (MHz)	Data Rate (Mbps)	Measurement Level (dB)	Required Limit (dB)	Result
100	5500	MCS (8)	9.340	<13	Pass
		MCS (10)	9.140	<13	Pass
		MCS (12)	9.890	<13	Pass
		MCS (15)	9.730	<13	Pass

Channel 100:

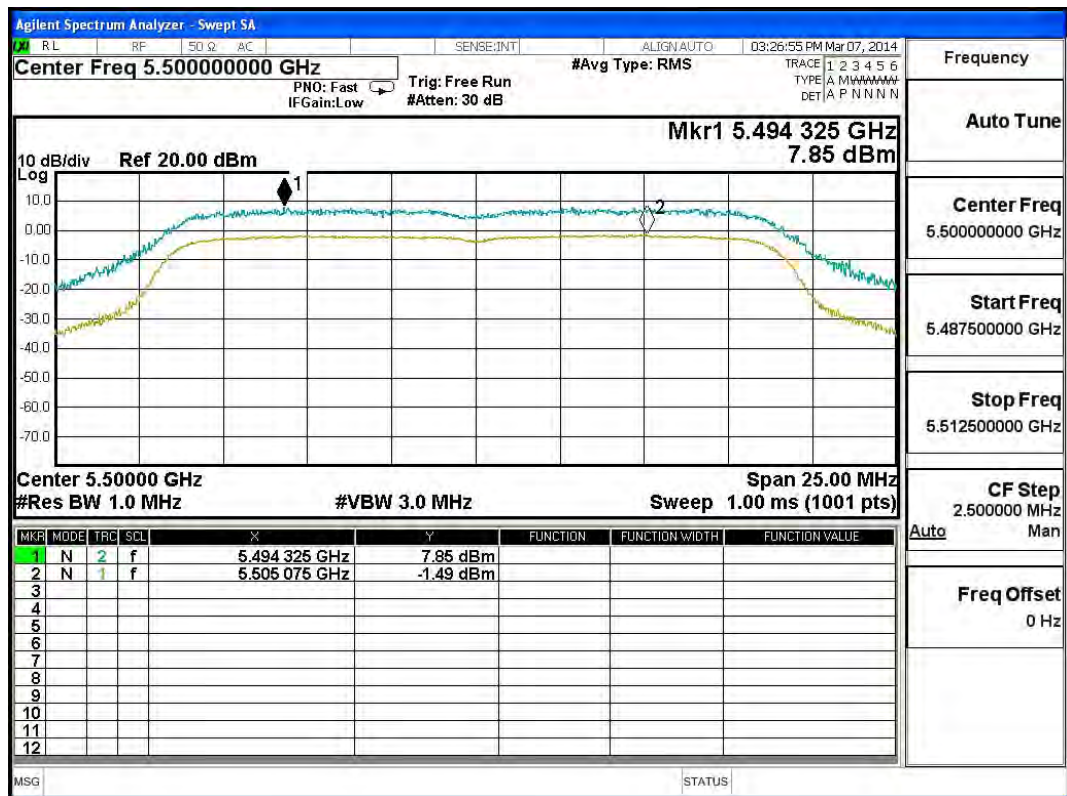

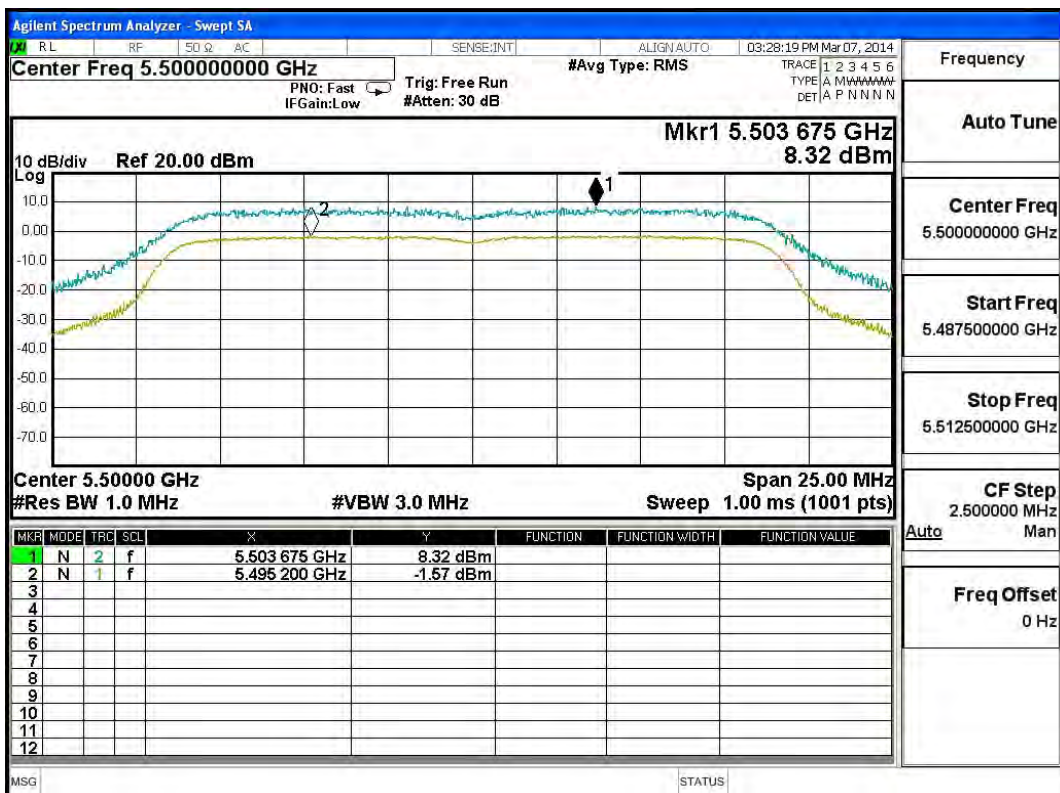
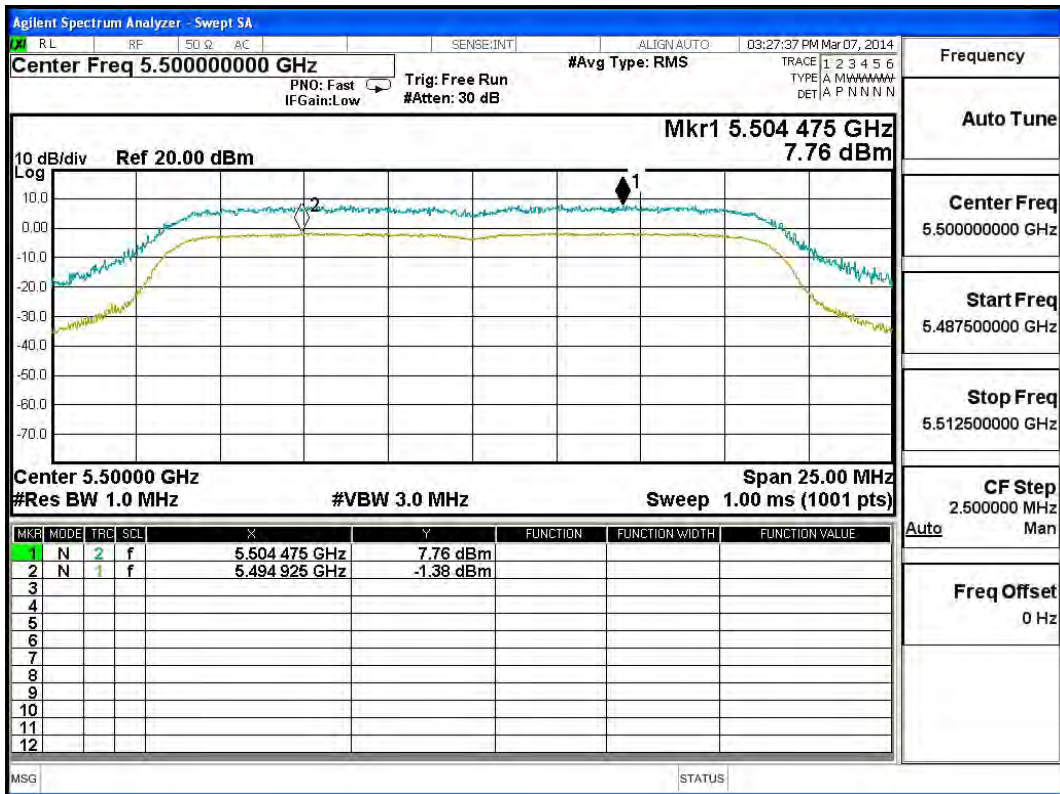

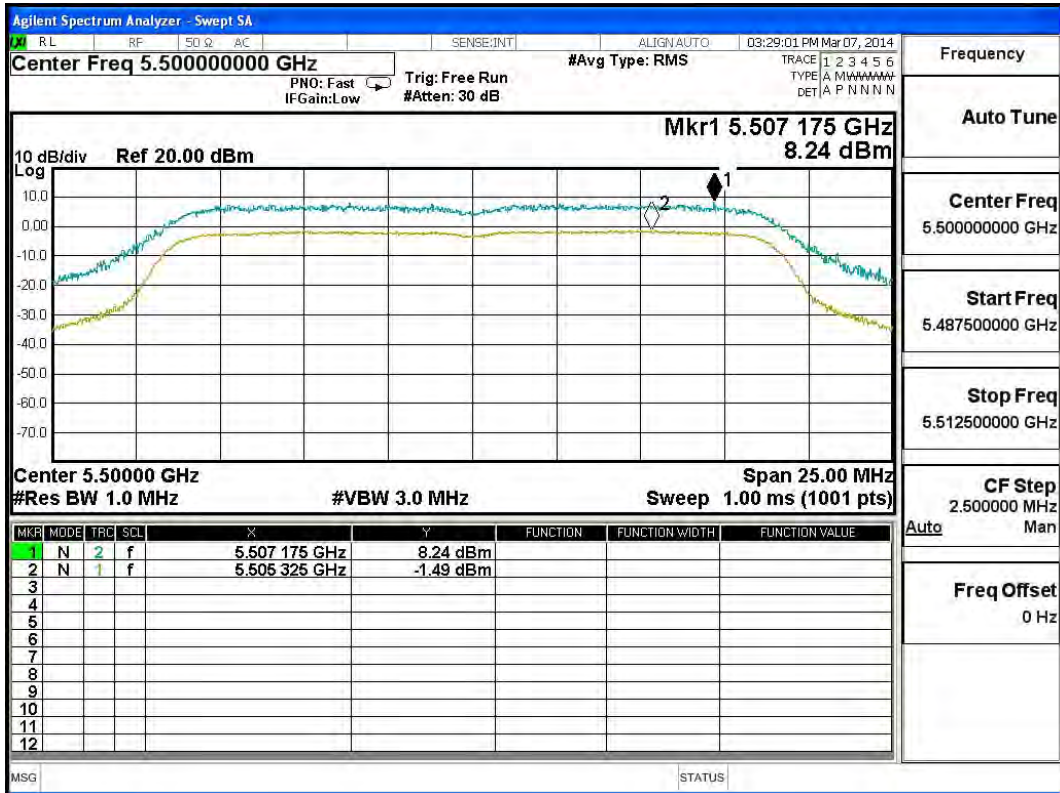

Product : Wireless Motherboard
 Test Item : Peak Excursion
 Test Site : No.3 OATS
 Test Mode : Mode 3: Transmit (802.11n-40BW 30Mbps)

Chain A

Channel No.	Frequency (MHz)	Data Rate (Mbps)	Measurement Level (dB)	Required Limit (dB)	Result
102	5510	MCS (8)	9.560	<13	Pass
		MCS (10)	9.460	<13	Pass
		MCS (12)	9.140	<13	Pass
		MCS (15)	9.590	<13	Pass

Channel 102:

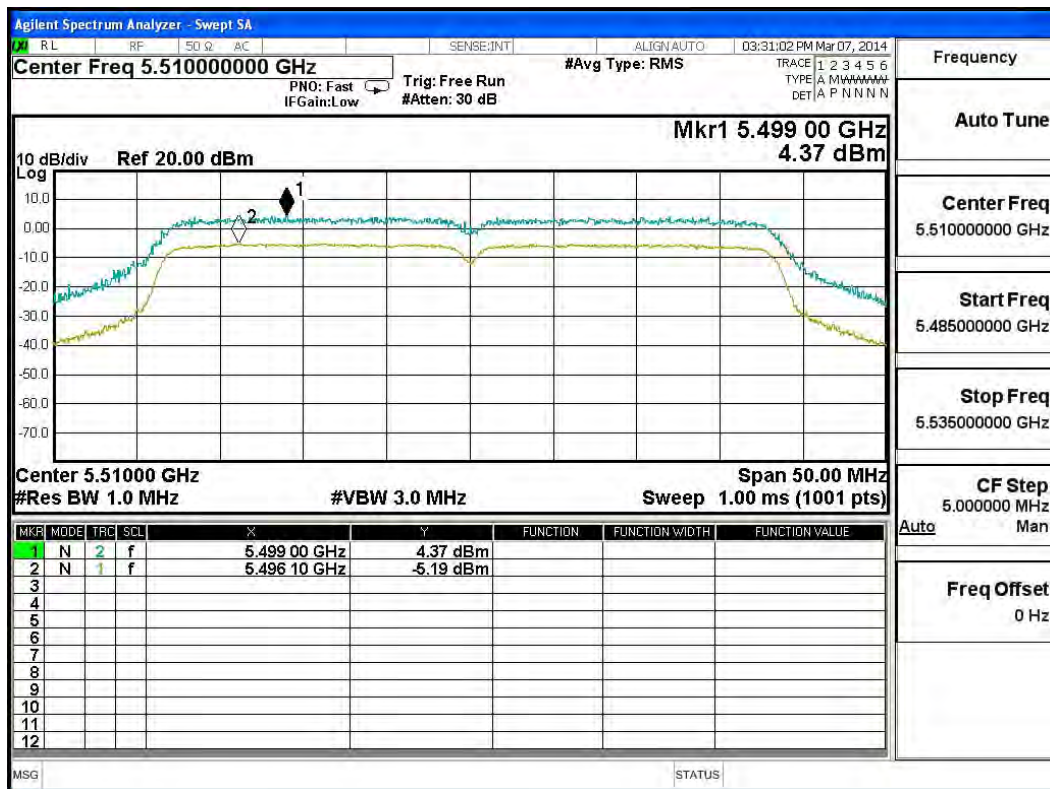

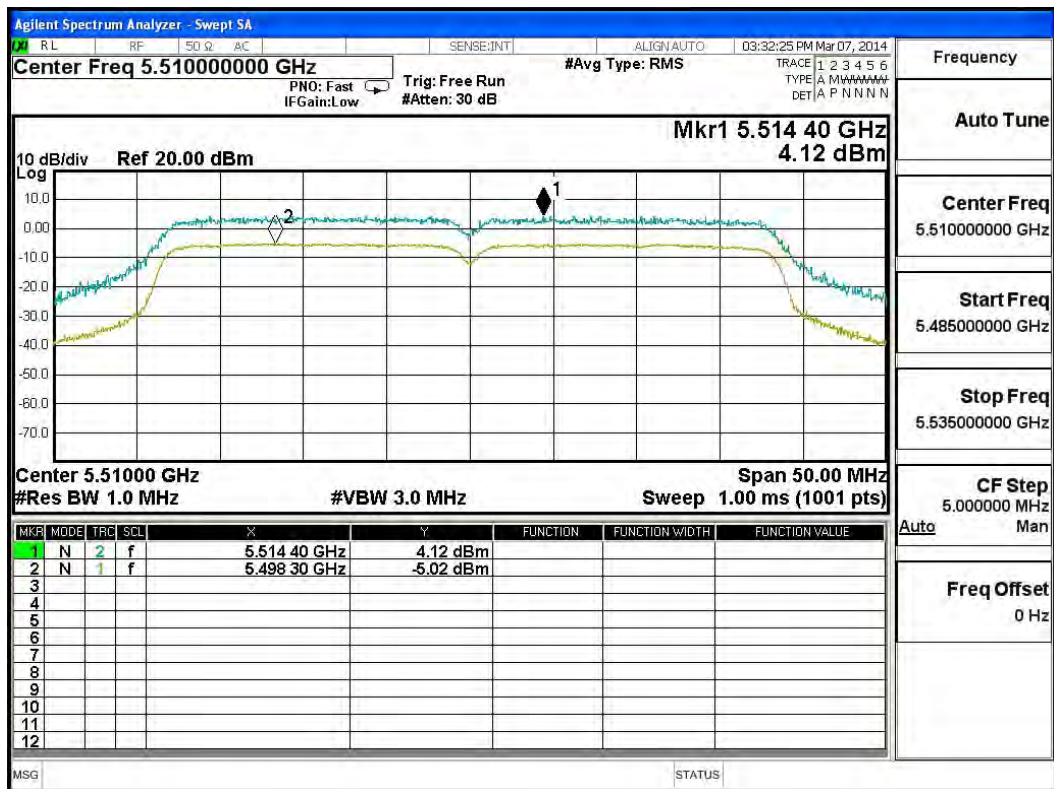
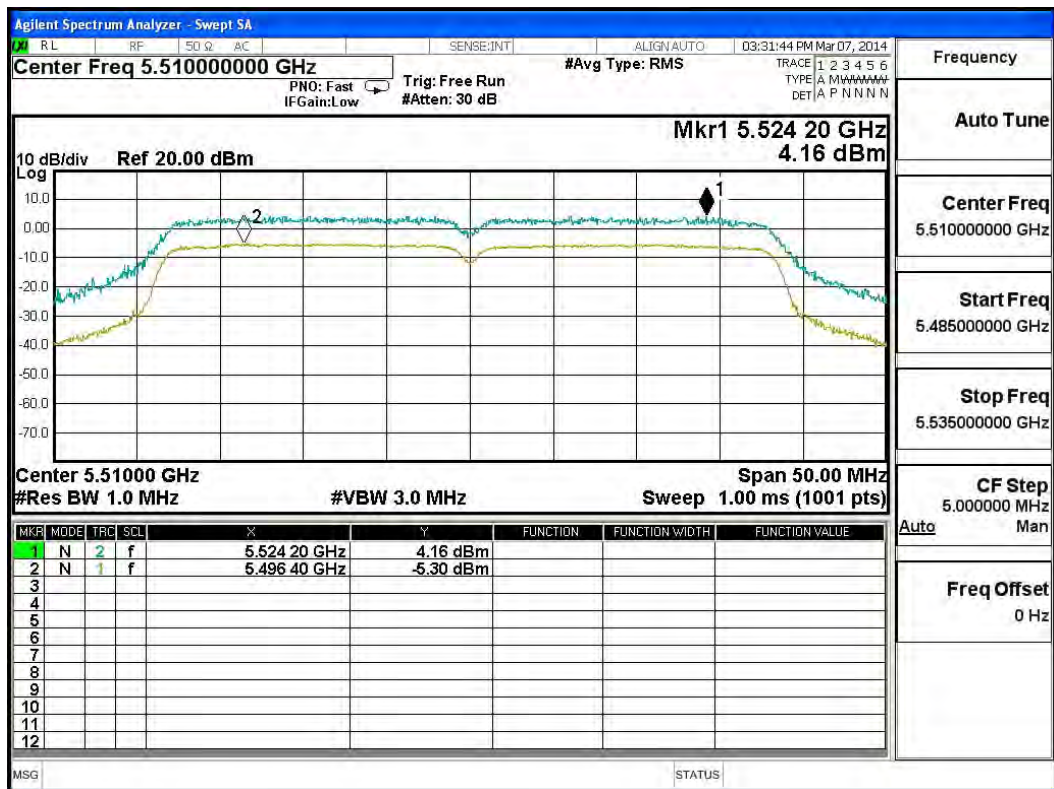

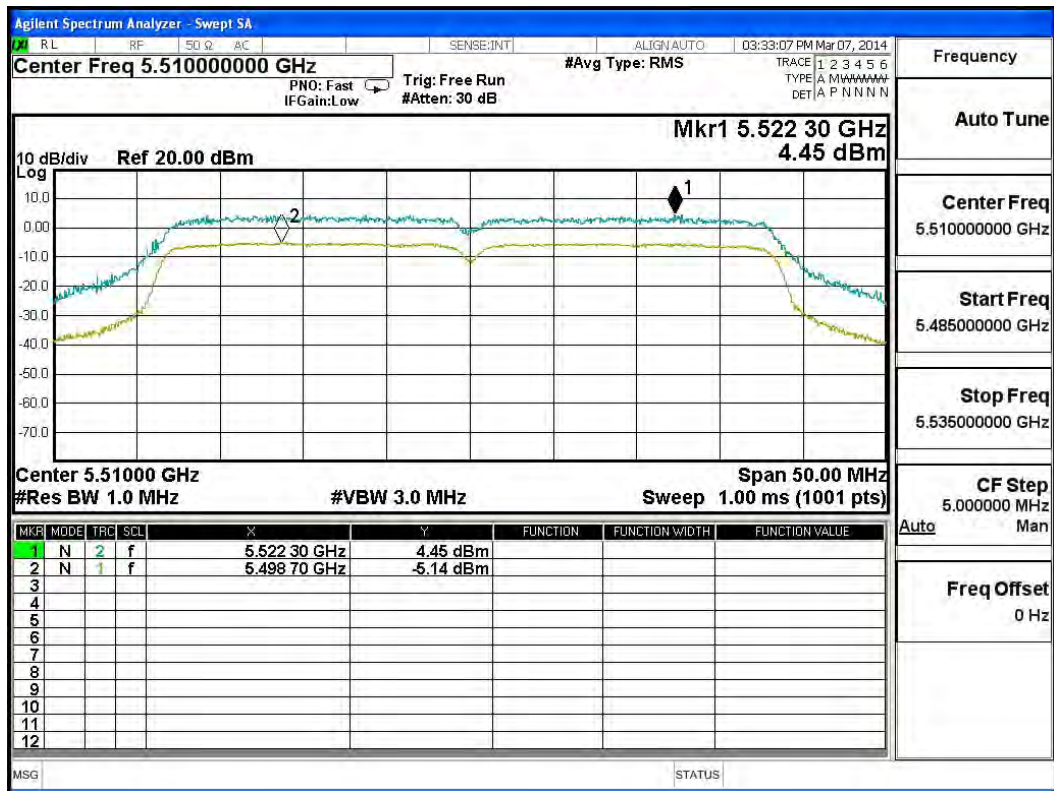

Chain B

Channel No.	Frequency (MHz)	Data Rate (Mbps)	Measurement Level (dB)	Required Limit (dB)	Result
102	5510	MCS (8)	9.990	<13	Pass
		MCS (10)	9.750	<13	Pass
		MCS (12)	10.390	<13	Pass
		MCS (15)	9.670	<13	Pass

Channel 102:

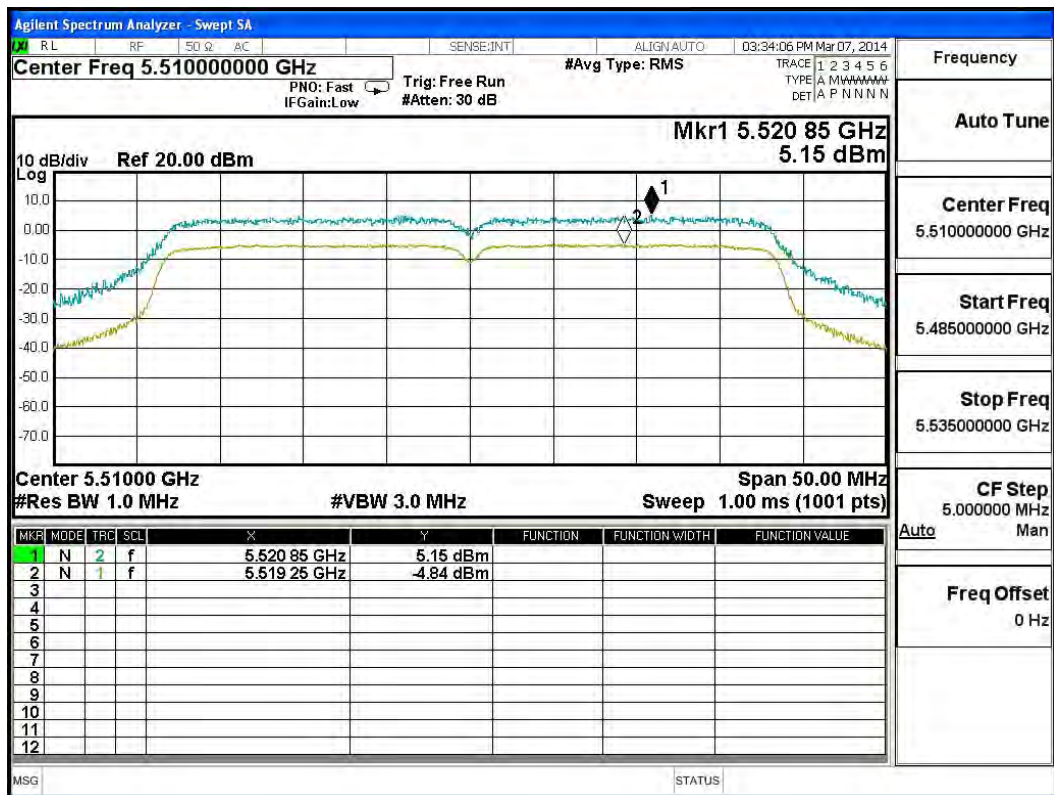

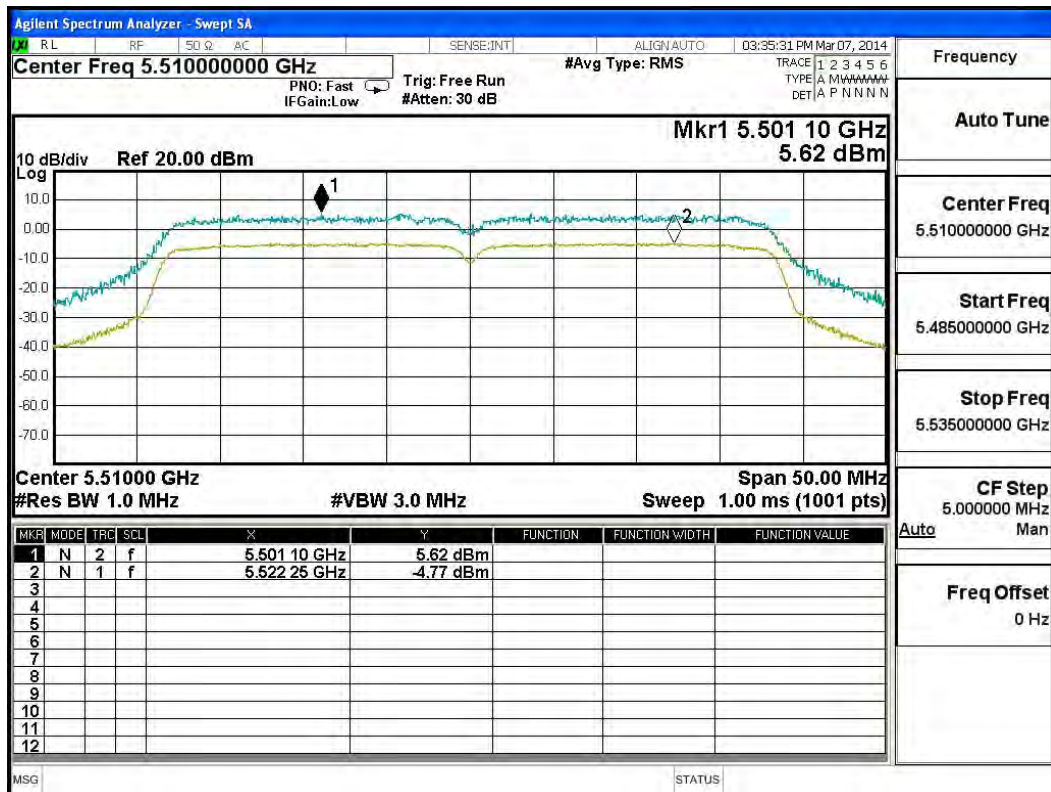
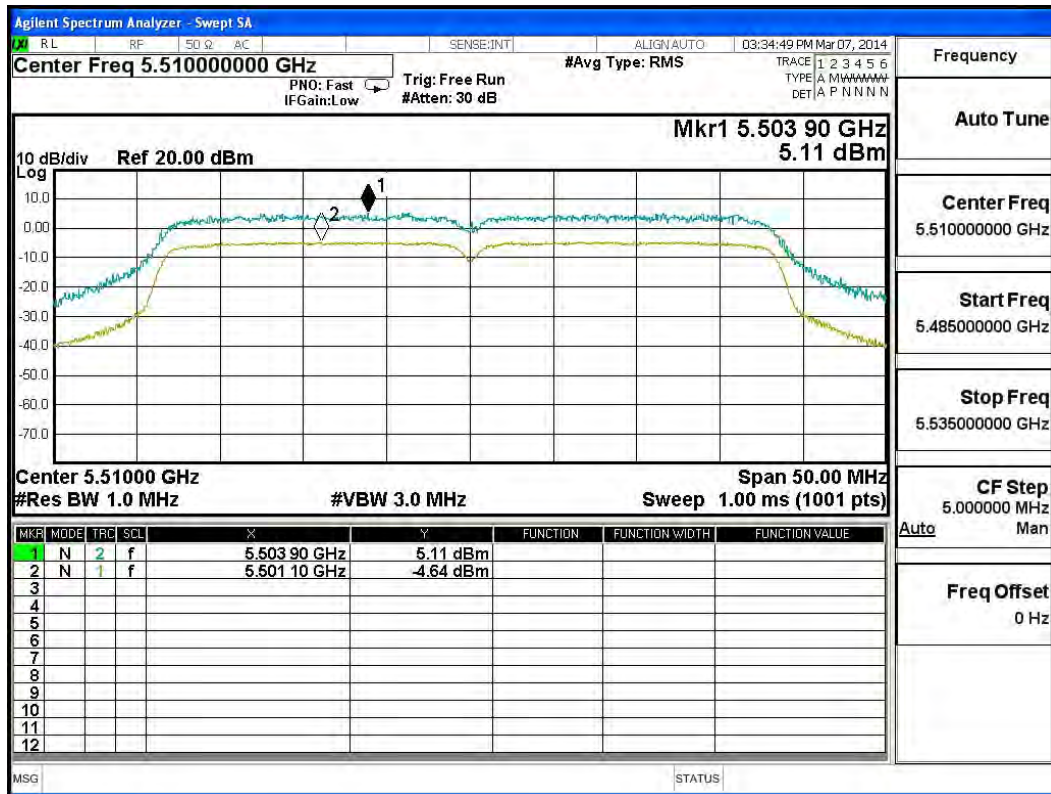

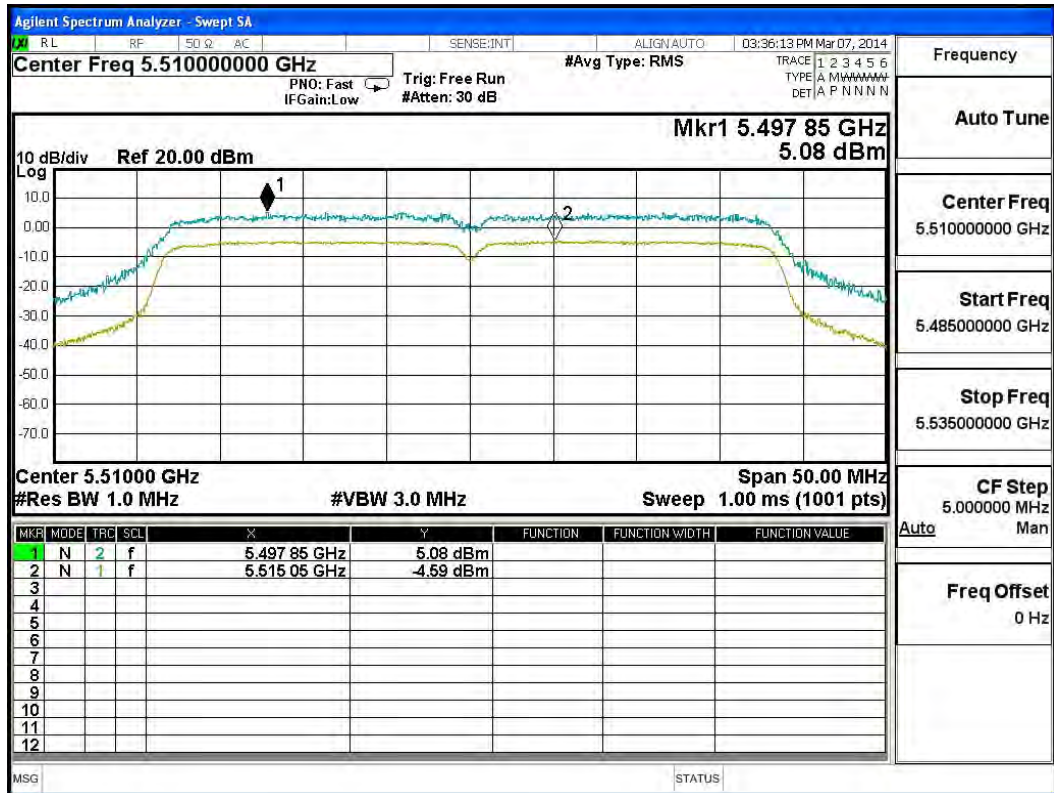

6. Radiated Emission

6.1. Test Equipment

The following test equipments are used during the radiated emission test:

Test Site	Equipment	Manufacturer	Model No./Serial No.	Last Cal.
☒ Site # 3	X Loop Antenna	Teseq	HLA6120 / 26739	Jul., 2013
	X Bilog Antenna	Schaffner Chase	CBL6112B/2673	Sep., 2013
	X Horn Antenna	Schwarzbeck	BBHA9120D/D305	Sep., 2013
	X Horn Antenna	Schwarzbeck	BBHA9170/208	Jul., 2013
	X Pre-Amplifier	QTK	QTK-AMP-03 / 0003	May, 2013
	X Pre-Amplifier	QTK	AP-180C / CHM_0906076	Sep., 2013
	X Pre-Amplifier	MITEQ	AMF-4D-180400-45-6P/ 925975	Mar, 2014
	X Spectrum Analyzer	Agilent	E4407B / US39440758	May, 2013
	X Test Receiver	R & S	ESCS 30/ 825442/018	Sep., 2013
	X Coaxial Cable	QuieTek	QTK-CABLE/ CAB5	Feb., 2014
	X Controller	QuieTek	QTK-CONTROLLER/ CTRL3	N/A
	X Coaxial Switch	Anritsu	MP59B/6200265729	N/A

- Note:
1. All equipments are calibrated with traceable calibrations. Each calibration is traceable to the national or international standards.
 2. The test instruments marked with “X” are used to measure the final test results.

6.2. Test Setup

Radiated Emission Below 1GHz

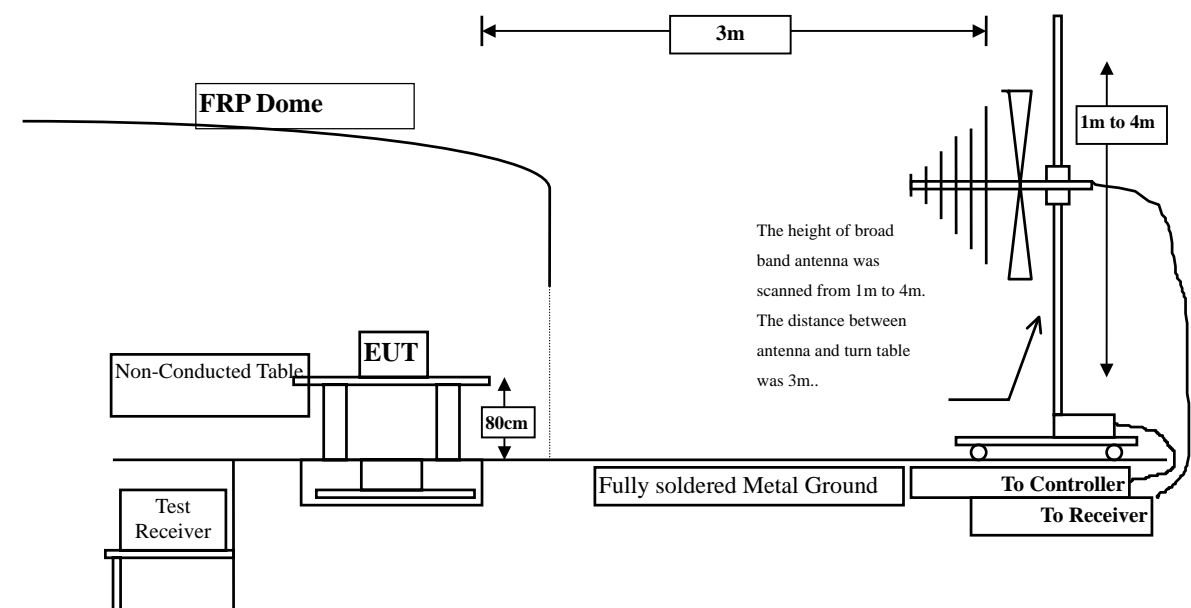

Radiated Emission Above 1GHz

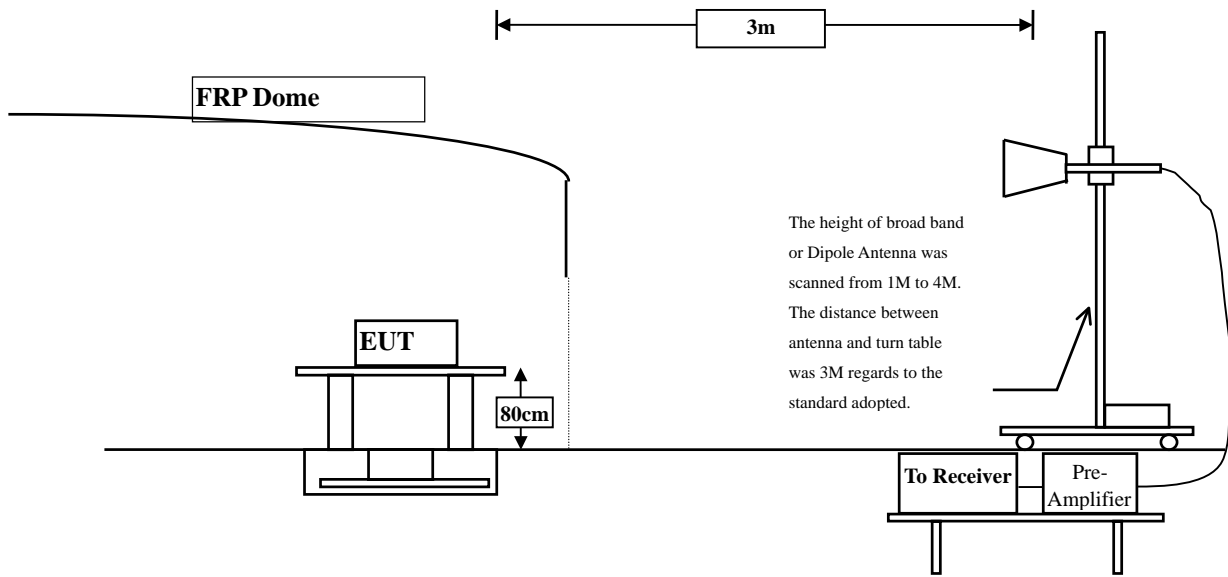

6.3. Limits

Emissions radiated outside of the specified frequency bands, except for harmonics, shall be attenuated by at least 20dB below the level of the fundamental or to the general radiated emission limits in paragraph 15.209, whichever is the lesser attenuation.

FCC Part 15 Subpart C Paragraph 15.209(a) Limits		
Frequency MHz	Field strength (microvolts/meter)	Measurement distance (meter)
0.009-0.490	2400/F(kHz)	300
0.490-1.705	24000/F(kHz)	30
1.705-30	30	30
30-88	100	3
88-216	150	3
216-960	200	3
Above 960	500	3

Remarks: E field strength (dBuV/m) = 20 log E field strength (uV/m)

6.4. Test Procedure

The EUT was setup according to ANSI C63.10, 2009 and tested according to FCC KDB-789033 test procedure for compliance to FCC 47CFR 15. 407 requirements.

The EUT is placed on a turn table which is 0.8 meter above ground. The turn table is rotated 360 degrees to determine the position of the maximum emission level. The EUT was positioned such that the distance from antenna to the EUT was 3 meters.

The antenna is scanned from 1 meter to 4 meters to find out the maximum emission level. This is repeated for both horizontal and vertical polarization of the antenna. In order to find the maximum emission, all of the interface cables were manipulated according to ANSI C63.10, 2009 on radiated measurement.

The resolution bandwidth below 30MHz setting on the field strength meter is 9kHz and 30MHz~1GHz is 120kHz and above 1GHz is 1MHz.

Radiated emission measurements below 30MHz are made using Loop Antenna and 30MHz~1GHz are made using broadband Bilog antenna and above 1GHz are made using Horn Antennas.

The measurement is divided into the Preliminary Measurement and the Final Measurement.

The suspected frequencies are searched for in Preliminary Measurement with the measurement antenna kept pointed at the source of the emission both in azimuth and elevation, with the polarization of the antenna oriented for maximum response. The antenna is pointed at an angle towards the source of the emission, and the EUT is rotated in both height and polarization to maximize the measured emission. The emission is kept within the illumination area of the 3 dB bandwidth of the antenna.

The worst radiated emission is measured in the Open Area Test Site on the Final Measurement.

The measurement frequency range form 9KHz - 10th Harmonic of fundamental was investigated.

6.5. Uncertainty

± 3.8 dB below 1GHz

± 3.9 dB above 1GHz

6.6. Test Result of Radiated Emission

Product : Wireless Motherboard
 Test Item : Harmonic Radiated Emission Data
 Test Site : No.3 OATS
 Test Mode : Mode 1: Transmit (802.11a-6Mbps) (5180MHz) (Chip Antenna)

Frequency MHz	Correct Factor dB	Reading Level dBuV	Measurement Level dBuV/m	Margin dB	Limit dBuV/m
Horizontal					
Peak Detector:					
10360.000	12.930	36.740	49.670	-24.330	74.000
15540.000	*	*	*	*	74.000
20720.000	*	*	*	*	74.000
25900.000	*	*	*	*	74.000
31080.000	*	*	*	*	74.000
36260.000	*	*	*	*	74.000
Average Detector:					
--					
Vertical					
Peak Detector:					
10360.000	13.724	37.290	51.014	-22.986	74.000
20720.000	*	*	*	*	74.000
25900.000	*	*	*	*	74.000
31080.000	*	*	*	*	74.000
36260.000	*	*	*	*	74.000
Average Detector:					
--					

Note:

1. All Readings below 1GHz are Quasi-Peak, above 1GHz are performed with peak and/or average measurements as necessary.
2. Peak measurements: RBW = 1MHz, VBW = 3 MHz, Sweep: Auto.
3. Average measurements: RBW = 1MHz, VBW = 10 Hz, Sweep: Auto.
4. Measurement Level = Reading Level + Correct Factor.
5. Correct Factor = Antenna factor + Cable loss – Amplifier gain.
6. The average measurement was not performed when the peak measured data under the limit of average detection.
7. The emission levels of other frequencies are very lower than the limit and not show in test report.

Product : Wireless Motherboard
 Test Item : Harmonic Radiated Emission Data
 Test Site : No.3 OATS
 Test Mode : Mode 1: Transmit (802.11a-6Mbps) (5220MHz) (Chip Antenna)

Frequency MHz	Correct Factor dB	Reading Level dBuV	Measurement Level dBuV/m	Margin dB	Limit dBuV/m
Horizontal					
Peak Detector:					
10440.000	13.322	36.680	50.002	-23.998	74.000
15600.000	*	*	*	*	74.000
20800.000	*	*	*	*	74.000
26000.000	*	*	*	*	74.000
31200.000	*	*	*	*	74.000
36400.000	*	*	*	*	74.000
Average Detector:					
--					
Vertical					
Peak Detector:					
10440.000	14.245	37.720	51.965	-22.035	74.000
20800.000	*	*	*	*	74.000
26000.000	*	*	*	*	74.000
31200.000	*	*	*	*	74.000
36400.000	*	*	*	*	74.000
Average Detector:					
--					

Note:

1. All Readings below 1GHz are Quasi-Peak, above 1GHz are performed with peak and/or average measurements as necessary.
2. Peak measurements: RBW = 1MHz, VBW = 3 MHz, Sweep: Auto.
3. Average measurements: RBW = 1MHz, VBW = 10 Hz, Sweep: Auto.
4. Measurement Level = Reading Level + Correct Factor.
5. Correct Factor = Antenna factor + Cable loss – Amplifier gain.
6. The average measurement was not performed when the peak measured data under the limit of average detection.
7. The emission levels of other frequencies are very lower than the limit and not show in test report.

Product : Wireless Motherboard
 Test Item : Harmonic Radiated Emission Data
 Test Site : No.3 OATS
 Test Mode : Mode 1: Transmit (802.11a-6Mbps) (5240MHz) (Chip Antenna)

Frequency MHz	Correct Factor dB	Reading Level dBuV	Measurement Level dBuV/m	Margin dB	Limit dBuV/m
Horizontal					
Peak Detector:					
10480.000	13.693	36.560	50.254	-23.746	74.000
15720.000	*	*	*	*	74.000
20960.000	*	*	*	*	74.000
26200.000	*	*	*	*	74.000
31440000	*	*	*	*	74.000
36680.000	*	*	*	*	74.000
Average Detector:					
--					
Vertical					
Peak Detector:					
10480.000	14.620	37.240	51.861	-22.139	74.000
20960.000	*	*	*	*	74.000
26200.000	*	*	*	*	74.000
31440000	*	*	*	*	74.000
36680.000	*	*	*	*	74.000
Average Detector:					
--					

Note:

1. All Readings below 1GHz are Quasi-Peak, above 1GHz are performed with peak and/or average measurements as necessary.
2. Peak measurements: RBW = 1MHz, VBW = 3 MHz, Sweep: Auto.
3. Average measurements: RBW = 1MHz, VBW = 10 Hz, Sweep: Auto.
4. Measurement Level = Reading Level + Correct Factor.
5. Correct Factor = Antenna factor + Cable loss – Amplifier gain.
6. The average measurement was not performed when the peak measured data under the limit of average detection.
7. The emission levels of other frequencies are very lower than the limit and not show in test report.

Product : Wireless Motherboard
 Test Item : Harmonic Radiated Emission Data
 Test Site : No.3 OATS
 Test Mode : Mode 1: Transmit (802.11a-6Mbps) (5260MHz) (Chip Antenna)

Frequency MHz	Correct Factor dB	Reading Level dBuV	Measurement Level dBuV/m	Margin dB	Limit dBuV/m
Horizontal					
Peak Detector:					
10520.000	14.015	36.140	50.155	-23.845	74.000
15780.000	*	*	*	*	74.000
21040.000	*	*	*	*	74.000
26300.000	*	*	*	*	74.000
31560.000	*	*	*	*	74.000
36820.000	*	*	*	*	74.000
Average Detector:					
--					
Vertical					
Peak Detector:					
10520.000	14.818	37.180	51.998	-22.002	74.000
15780.000	*	*	*	*	74.000
21040.000	*	*	*	*	74.000
26300.000	*	*	*	*	74.000
31560.000	*	*	*	*	74.000
36820.000	*	*	*	*	74.000
Average Detector:					
--					

Note:

1. All Readings below 1GHz are Quasi-Peak, above 1GHz are performed with peak and/or average measurements as necessary.
2. Peak measurements: RBW = 1MHz, VBW = 3 MHz, Sweep: Auto.
3. Average measurements: RBW = 1MHz, VBW = 10 Hz, Sweep: Auto.
4. Measurement Level = Reading Level + Correct Factor.
5. Correct Factor = Antenna factor + Cable loss – Amplifier gain.
6. The average measurement was not performed when the peak measured data under the limit of average detection.
7. The emission levels of other frequencies are very lower than the limit and not show in test report.

Product : Wireless Motherboard
 Test Item : Harmonic Radiated Emission Data
 Test Site : No.3 OATS
 Test Mode : Mode 1: Transmit (802.11a-6Mbps) (5300MHz) (Chip Antenna)

Frequency MHz	Correct Factor dB	Reading Level dBuV	Measurement Level dBuV/m	Margin dB	Limit dBuV/m
Horizontal					
Peak Detector:					
10600.000	14.550	36.560	51.109	-22.891	74.000
15900.000	*	*	*	*	74.000
21200.000	*	*	*	*	74.000
26500.000	*	*	*	*	74.000
31800.000	*	*	*	*	74.000
37100.000	*	*	*	*	74.000
Average Detector:					
--					
Vertical					
Peak Detector:					
10600.000	14.881	38.720	53.601	-20.399	74.000
15900.000	*	*	*	*	74.000
21200.000	*	*	*	*	74.000
26500.000	*	*	*	*	74.000
31800.000	*	*	*	*	74.000
37100.000	*	*	*	*	74.000
Average Detector:					
--					

Note:

1. All Readings below 1GHz are Quasi-Peak, above 1GHz are performed with peak and/or average measurements as necessary.
2. Peak measurements: RBW = 1MHz, VBW = 3 MHz, Sweep: Auto.
3. Average measurements: RBW = 1MHz, VBW = 10 Hz, Sweep: Auto.
4. Measurement Level = Reading Level + Correct Factor.
5. Correct Factor = Antenna factor + Cable loss – Amplifier gain.
6. The average measurement was not performed when the peak measured data under the limit of average detection.
7. The emission levels of other frequencies are very lower than the limit and not show in test report.

Product : Wireless Motherboard
 Test Item : Harmonic Radiated Emission Data
 Test Site : No.3 OATS
 Test Mode : Mode 1: Transmit (802.11a-6Mbps) (5320MHz) (Chip Antenna)

Frequency MHz	Correct Factor dB	Reading Level dBuV	Measurement Level dBuV/m	Margin dB	Limit dBuV/m
Horizontal					
Peak Detector:					
10640.000	14.690	36.570	51.260	-22.740	74.000
15960.000	*	*	*	*	74.000
21280.000	*	*	*	*	74.000
26600.000	*	*	*	*	74.000
31920.000	*	*	*	*	74.000
37240.000	*	*	*	*	74.000
Average Detector:					
--					
Vertical					
Peak Detector:					
10640.000	15.083	36.550	51.633	-22.367	74.000
15960.000	*	*	*	*	74.000
21280.000	*	*	*	*	74.000
26600.000	*	*	*	*	74.000
31920.000	*	*	*	*	74.000
37240.000	*	*	*	*	74.000
Average Detector:					
--					

Note:

1. All Readings below 1GHz are Quasi-Peak, above 1GHz are performed with peak and/or average measurements as necessary.
2. Peak measurements: RBW = 1MHz, VBW = 3 MHz, Sweep: Auto.
3. Average measurements: RBW = 1MHz, VBW = 10 Hz, Sweep: Auto.
4. Measurement Level = Reading Level + Correct Factor.
5. Correct Factor = Antenna factor + Cable loss – Amplifier gain.
6. The average measurement was not performed when the peak measured data under the limit of average detection.
7. The emission levels of other frequencies are very lower than the limit and not show in test report.

Product : Wireless Motherboard
 Test Item : Harmonic Radiated Emission Data
 Test Site : No.3 OATS
 Test Mode : Mode 1: Transmit (802.11a-6Mbps) (5500MHz) (Chip Antenna)

Frequency MHz	Correct Factor dB	Reading Level dBuV	Measurement Level dBuV/m	Margin dB	Limit dBuV/m
Horizontal					
Peak Detector:					
11000.000	16.399	37.460	53.859	-20.141	74.000
16500.000	*	*	*	*	74.000
22000.000	*	*	*	*	74.000
27500.000	*	*	*	*	74.000
33000.000	*	*	*	*	74.000
38500.000	*	*	*	*	74.000
Average Detector:					
--					
Vertical					
Peak Detector:					
11000.000	17.132	40.070	57.202	-16.798	74.000
16500.000	*	*	*	*	74.000
22000.000	*	*	*	*	74.000
27500.000	*	*	*	*	74.000
33000.000	*	*	*	*	74.000
38500.000	*	*	*	*	74.000
Average Detector:					
11000.000	17.132	27.860	44.992	-9.008	54.000

Note:

1. All Readings below 1GHz are Quasi-Peak, above 1GHz are performed with peak and/or average measurements as necessary.
2. Peak measurements: RBW = 1MHz, VBW = 3 MHz, Sweep: Auto.
3. Average measurements: RBW = 1MHz, VBW = 10 Hz, Sweep: Auto.
4. Measurement Level = Reading Level + Correct Factor.
5. Correct Factor = Antenna factor + Cable loss – Amplifier gain.
6. The average measurement was not performed when the peak measured data under the limit of average detection.
7. The emission levels of other frequencies are very lower than the limit and not show in test report.

Product : Wireless Motherboard
 Test Item : Harmonic Radiated Emission Data
 Test Site : No.3 OATS
 Test Mode : Mode 1: Transmit (802.11a-6Mbps) (5580MHz) (Chip Antenna)

Frequency MHz	Correct Factor dB	Reading Level dBuV	Measurement Level dBuV/m	Margin dB	Limit dBuV/m
Horizontal					
Peak Detector:					
11160.000	16.664	41.710	58.375	-15.625	74.000
16740.000	*	*	*	*	74.000
22320.000	*	*	*	*	74.000
27900.000	*	*	*	*	74.000
33480.000	*	*	*	*	74.000
39060.000	*	*	*	*	74.000
Average Detector:					
11160.000	16.664	27.520	44.185	-9.815	54.000
Vertical					
Peak Detector:					
11160.000	17.643	43.490	61.133	-12.867	74.000
16740.000	*	*	*	*	74.000
22320.000	*	*	*	*	74.000
27900.000	*	*	*	*	74.000
33480.000	*	*	*	*	74.000
39060.000	*	*	*	*	74.000
Average Detector:					
11160.000	17.643	29.230	46.873	-7.127	54.000

Note:

1. All Readings below 1GHz are Quasi-Peak, above 1GHz are performed with peak and/or average measurements as necessary.
2. Peak measurements: RBW = 1MHz, VBW = 3 MHz, Sweep: Auto.
3. Average measurements: RBW = 1MHz, VBW = 10 Hz, Sweep: Auto.
4. Measurement Level = Reading Level + Correct Factor.
5. Correct Factor = Antenna factor + Cable loss – Amplifier gain.
6. The average measurement was not performed when the peak measured data under the limit of average detection.
7. The emission levels of other frequencies are very lower than the limit and not show in test report.

Product : Wireless Motherboard
 Test Item : Harmonic Radiated Emission Data
 Test Site : No.3 OATS
 Test Mode : Mode 1: Transmit (802.11a-6Mbps) (5700MHz) (Chip Antenna)

Frequency MHz	Correct Factor dB	Reading Level dBuV	Measurement Level dBuV/m	Margin dB	Limit dBuV/m
Horizontal					
Peak Detector:					
11400.000	16.530	41.160	57.691	-16.309	74.000
17100.000	*	*	*	*	74.000
22800.000	*	*	*	*	74.000
28500.000	*	*	*	*	74.000
34200.000	*	*	*	*	74.000
39900.000	*	*	*	*	74.000
Average Detector:					
11400.000	16.530	26.960	43.491	-10.509	54.000
Vertical					
Peak Detector:					
11400.000	17.138	41.590	58.728	-15.272	74.000
17100.000	*	*	*	*	74.000
22800.000	*	*	*	*	74.000
28500.000	*	*	*	*	74.000
34200.000	*	*	*	*	74.000
39900.000	*	*	*	*	74.000
Average Detector:					
11400.000	17.138	26.560	43.698	-10.302	54.000

Note:

1. All Readings below 1GHz are Quasi-Peak, above 1GHz are performed with peak and/or average measurements as necessary.
2. Peak measurements: RBW = 1MHz, VBW = 3 MHz, Sweep: Auto.
3. Average measurements: RBW = 1MHz, VBW = 10 Hz, Sweep: Auto.
4. Measurement Level = Reading Level + Correct Factor.
5. Correct Factor = Antenna factor + Cable loss – Amplifier gain.
6. The average measurement was not performed when the peak measured data under the limit of average detection.
7. The emission levels of other frequencies are very lower than the limit and not show in test report.

Product : Wireless Motherboard
 Test Item : Harmonic Radiated Emission Data
 Test Site : No.3 OATS
 Test Mode : Mode 1: Transmit (802.11a-6Mbps) (5180MHz) (PIFA Antenna)

Frequency MHz	Correct Factor dB	Reading Level dBuV	Measurement Level dBuV/m	Margin dB	Limit dBuV/m
Horizontal					
Peak Detector:					
10360.000	12.930	36.480	49.410	-24.590	74.000
15540.000	*	*	*	*	74.000
20720.000	*	*	*	*	74.000
25900.000	*	*	*	*	74.000
31080.000	*	*	*	*	74.000
36260.000	*	*	*	*	74.000
Average Detector:					
--					
Vertical					
Peak Detector:					
10360.000	13.724	36.320	50.044	-23.956	74.000
20720.000	*	*	*	*	74.000
25900.000	*	*	*	*	74.000
31080.000	*	*	*	*	74.000
36260.000	*	*	*	*	74.000
Average Detector:					
--					

Note:

1. All Readings below 1GHz are Quasi-Peak, above 1GHz are performed with peak and/or average measurements as necessary.
2. Peak measurements: RBW = 1MHz, VBW = 3 MHz, Sweep: Auto.
3. Average measurements: RBW = 1MHz, VBW = 10 Hz, Sweep: Auto.
4. Measurement Level = Reading Level + Correct Factor.
5. Correct Factor = Antenna factor + Cable loss – Amplifier gain.
6. The average measurement was not performed when the peak measured data under the limit of average detection.
7. The emission levels of other frequencies are very lower than the limit and not show in test report.

Product : Wireless Motherboard
 Test Item : Harmonic Radiated Emission Data
 Test Site : No.3 OATS
 Test Mode : Mode 1: Transmit (802.11a-6Mbps) (5220MHz) (PIFA Antenna)

Frequency MHz	Correct Factor dB	Reading Level dBuV	Measurement Level dBuV/m	Margin dB	Limit dBuV/m
Horizontal					
Peak Detector:					
10440.000	13.322	36.770	50.092	-23.908	74.000
15600.000	*	*	*	*	74.000
20800.000	*	*	*	*	74.000
26000.000	*	*	*	*	74.000
31200.000	*	*	*	*	74.000
36400.000	*	*	*	*	74.000
Average Detector:					
--					
Vertical					
Peak Detector:					
10440.000	14.245	36.890	51.135	-22.865	74.000
20800.000	*	*	*	*	74.000
26000.000	*	*	*	*	74.000
31200.000	*	*	*	*	74.000
36400.000	*	*	*	*	74.000
Average Detector:					
--					

Note:

1. All Readings below 1GHz are Quasi-Peak, above 1GHz are performed with peak and/or average measurements as necessary.
2. Peak measurements: RBW = 1MHz, VBW = 3 MHz, Sweep: Auto.
3. Average measurements: RBW = 1MHz, VBW = 10 Hz, Sweep: Auto.
4. Measurement Level = Reading Level + Correct Factor.
5. Correct Factor = Antenna factor + Cable loss – Amplifier gain.
6. The average measurement was not performed when the peak measured data under the limit of average detection.
7. The emission levels of other frequencies are very lower than the limit and not show in test report.

Product : Wireless Motherboard
 Test Item : Harmonic Radiated Emission Data
 Test Site : No.3 OATS
 Test Mode : Mode 1: Transmit (802.11a-6Mbps) (5240MHz) (PIFA Antenna)

Frequency MHz	Correct Factor dB	Reading Level dBuV	Measurement Level dBuV/m	Margin dB	Limit dBuV/m
Horizontal					
Peak Detector:					
10480.000	13.693	37.560	51.254	-22.746	74.000
15720.000	*	*	*	*	74.000
20960.000	*	*	*	*	74.000
26200.000	*	*	*	*	74.000
31440000	*	*	*	*	74.000
36680.000	*	*	*	*	74.000
Average Detector:					
--					
Vertical					
Peak Detector:					
10480.000	14.620	37.860	52.481	-21.519	74.000
20960.000	*	*	*	*	74.000
26200.000	*	*	*	*	74.000
31440000	*	*	*	*	74.000
36680.000	*	*	*	*	74.000
Average Detector:					
--					

Note:

1. All Readings below 1GHz are Quasi-Peak, above 1GHz are performed with peak and/or average measurements as necessary.
2. Peak measurements: RBW = 1MHz, VBW = 3 MHz, Sweep: Auto.
3. Average measurements: RBW = 1MHz, VBW = 10 Hz, Sweep: Auto.
4. Measurement Level = Reading Level + Correct Factor.
5. Correct Factor = Antenna factor + Cable loss – Amplifier gain.
6. The average measurement was not performed when the peak measured data under the limit of average detection.
7. The emission levels of other frequencies are very lower than the limit and not show in test report.

Product : Wireless Motherboard
 Test Item : Harmonic Radiated Emission Data
 Test Site : No.3 OATS
 Test Mode : Mode 1: Transmit (802.11a-6Mbps) (5260MHz) (PIFA Antenna)

Frequency MHz	Correct Factor dB	Reading Level dBuV	Measurement Level dBuV/m	Margin dB	Limit dBuV/m
Horizontal					
Peak Detector:					
10520.000	14.015	35.960	49.975	-24.025	74.000
15780.000	*	*	*	*	74.000
21040.000	*	*	*	*	74.000
26300.000	*	*	*	*	74.000
31560.000	*	*	*	*	74.000
36820.000	*	*	*	*	74.000
Average Detector:					
--					
Vertical					
Peak Detector:					
10520.000	14.818	36.890	51.708	-22.292	74.000
15780.000	*	*	*	*	74.000
21040.000	*	*	*	*	74.000
26300.000	*	*	*	*	74.000
31560.000	*	*	*	*	74.000
36820.000	*	*	*	*	74.000
Average Detector:					
--					

Note:

1. All Readings below 1GHz are Quasi-Peak, above 1GHz are performed with peak and/or average measurements as necessary.
2. Peak measurements: RBW = 1MHz, VBW = 3 MHz, Sweep: Auto.
3. Average measurements: RBW = 1MHz, VBW = 10 Hz, Sweep: Auto.
4. Measurement Level = Reading Level + Correct Factor.
5. Correct Factor = Antenna factor + Cable loss – Amplifier gain.
6. The average measurement was not performed when the peak measured data under the limit of average detection.
7. The emission levels of other frequencies are very lower than the limit and not show in test report.

Product : Wireless Motherboard
 Test Item : Harmonic Radiated Emission Data
 Test Site : No.3 OATS
 Test Mode : Mode 1: Transmit (802.11a-6Mbps) (5300MHz) (PIFA Antenna)

Frequency MHz	Correct Factor dB	Reading Level dBuV	Measurement Level dBuV/m	Margin dB	Limit dBuV/m
Horizontal					
Peak Detector:					
10600.000	14.550	35.510	50.059	-23.941	74.000
15900.000	*	*	*	*	74.000
21200.000	*	*	*	*	74.000
26500.000	*	*	*	*	74.000
31800.000	*	*	*	*	74.000
37100.000	*	*	*	*	74.000
Average Detector:					
--					
Vertical					
Peak Detector:					
10600.000	14.881	36.120	51.001	-22.999	74.000
15900.000	*	*	*	*	74.000
21200.000	*	*	*	*	74.000
26500.000	*	*	*	*	74.000
31800.000	*	*	*	*	74.000
37100.000	*	*	*	*	74.000
Average Detector:					
--					

Note:

1. All Readings below 1GHz are Quasi-Peak, above 1GHz are performed with peak and/or average measurements as necessary.
2. Peak measurements: RBW = 1MHz, VBW = 3 MHz, Sweep: Auto.
3. Average measurements: RBW = 1MHz, VBW = 10 Hz, Sweep: Auto.
4. Measurement Level = Reading Level + Correct Factor.
5. Correct Factor = Antenna factor + Cable loss – Amplifier gain.
6. The average measurement was not performed when the peak measured data under the limit of average detection.
7. The emission levels of other frequencies are very lower than the limit and not show in test report.

Product : Wireless Motherboard
 Test Item : Harmonic Radiated Emission Data
 Test Site : No.3 OATS
 Test Mode : Mode 1: Transmit (802.11a-6Mbps) (5320MHz) (PIFA Antenna)

Frequency MHz	Correct Factor dB	Reading Level dBuV	Measurement Level dBuV/m	Margin dB	Limit dBuV/m
Horizontal					
Peak Detector:					
10640.000	14.690	36.120	50.810	-23.190	74.000
15960.000	*	*	*	*	74.000
21280.000	*	*	*	*	74.000
26600.000	*	*	*	*	74.000
31920.000	*	*	*	*	74.000
37240.000	*	*	*	*	74.000
Average Detector:					
--					
Vertical					
Peak Detector:					
10640.000	15.083	36.670	51.753	-22.247	74.000
15960.000	*	*	*	*	74.000
21280.000	*	*	*	*	74.000
26600.000	*	*	*	*	74.000
31920.000	*	*	*	*	74.000
37240.000	*	*	*	*	74.000
Average Detector:					
--					

Note:

1. All Readings below 1GHz are Quasi-Peak, above 1GHz are performed with peak and/or average measurements as necessary.
2. Peak measurements: RBW = 1MHz, VBW = 3 MHz, Sweep: Auto.
3. Average measurements: RBW = 1MHz, VBW = 10 Hz, Sweep: Auto.
4. Measurement Level = Reading Level + Correct Factor.
5. Correct Factor = Antenna factor + Cable loss – Amplifier gain.
6. The average measurement was not performed when the peak measured data under the limit of average detection.
7. The emission levels of other frequencies are very lower than the limit and not show in test report.

Product : Wireless Motherboard
 Test Item : Harmonic Radiated Emission Data
 Test Site : No.3 OATS
 Test Mode : Mode 1: Transmit (802.11a-6Mbps) (5500MHz) (PIFA Antenna)

Frequency MHz	Correct Factor dB	Reading Level dBuV	Measurement Level dBuV/m	Margin dB	Limit dBuV/m
Horizontal					
Peak Detector:					
11000.000	16.399	36.130	52.529	-21.471	74.000
16500.000	*	*	*	*	74.000
22000.000	*	*	*	*	74.000
27500.000	*	*	*	*	74.000
33000.000	*	*	*	*	74.000
38500.000	*	*	*	*	74.000
Average Detector:					
--					
Vertical					
Peak Detector:					
11000.000	17.132	36.450	53.582	-20.418	74.000
16500.000	*	*	*	*	74.000
22000.000	*	*	*	*	74.000
27500.000	*	*	*	*	74.000
33000.000	*	*	*	*	74.000
38500.000	*	*	*	*	74.000
Average Detector:					
--					

Note:

1. All Readings below 1GHz are Quasi-Peak, above 1GHz are performed with peak and/or average measurements as necessary.
2. Peak measurements: RBW = 1MHz, VBW = 3 MHz, Sweep: Auto.
3. Average measurements: RBW = 1MHz, VBW = 10 Hz, Sweep: Auto.
4. Measurement Level = Reading Level + Correct Factor.
5. Correct Factor = Antenna factor + Cable loss – Amplifier gain.
6. The average measurement was not performed when the peak measured data under the limit of average detection.
7. The emission levels of other frequencies are very lower than the limit and not show in test report.

Product : Wireless Motherboard
 Test Item : Harmonic Radiated Emission Data
 Test Site : No.3 OATS
 Test Mode : Mode 1: Transmit (802.11a-6Mbps) (5580MHz) (PIFA Antenna)

Frequency MHz	Correct Factor dB	Reading Level dBuV	Measurement Level dBuV/m	Margin dB	Limit dBuV/m
Horizontal					
Peak Detector:					
11160.000	16.664	35.800	52.465	-21.535	74.000
16740.000	*	*	*	*	74.000
22320.000	*	*	*	*	74.000
27900.000	*	*	*	*	74.000
33480.000	*	*	*	*	74.000
39060.000	*	*	*	*	74.000
Average Detector:					
--					
Vertical					
Peak Detector:					
11160.000	17.643	35.960	53.603	-20.397	74.000
16740.000	*	*	*	*	74.000
22320.000	*	*	*	*	74.000
27900.000	*	*	*	*	74.000
33480.000	*	*	*	*	74.000
39060.000	*	*	*	*	74.000
Average Detector:					
--					

Note:

1. All Readings below 1GHz are Quasi-Peak, above 1GHz are performed with peak and/or average measurements as necessary.
2. Peak measurements: RBW = 1MHz, VBW = 3 MHz, Sweep: Auto.
3. Average measurements: RBW = 1MHz, VBW = 10 Hz, Sweep: Auto.
4. Measurement Level = Reading Level + Correct Factor.
5. Correct Factor = Antenna factor + Cable loss – Amplifier gain.
6. The average measurement was not performed when the peak measured data under the limit of average detection.
7. The emission levels of other frequencies are very lower than the limit and not show in test report.

Product : Wireless Motherboard
 Test Item : Harmonic Radiated Emission Data
 Test Site : No.3 OATS
 Test Mode : Mode 1: Transmit (802.11a-6Mbps) (5700MHz) (PIFA Antenna)

Frequency MHz	Correct Factor dB	Reading Level dBuV	Measurement Level dBuV/m	Margin dB	Limit dBuV/m
Horizontal					
Peak Detector:					
11400.000	16.530	34.460	50.991	-23.009	74.000
17100.000	*	*	*	*	74.000
22800.000	*	*	*	*	74.000
28500.000	*	*	*	*	74.000
34200.000	*	*	*	*	74.000
39900.000	*	*	*	*	74.000
Average Detector:					
--					
Vertical					
Peak Detector:					
11400.000	17.138	35.790	52.928	-21.072	74.000
17100.000	*	*	*	*	74.000
22800.000	*	*	*	*	74.000
28500.000	*	*	*	*	74.000
34200.000	*	*	*	*	74.000
39900.000	*	*	*	*	74.000
Average Detector:					
--					

Note:

1. All Readings below 1GHz are Quasi-Peak, above 1GHz are performed with peak and/or average measurements as necessary.
2. Peak measurements: RBW = 1MHz, VBW = 3 MHz, Sweep: Auto.
3. Average measurements: RBW = 1MHz, VBW = 10 Hz, Sweep: Auto.
4. Measurement Level = Reading Level + Correct Factor.
5. Correct Factor = Antenna factor + Cable loss – Amplifier gain.
6. The average measurement was not performed when the peak measured data under the limit of average detection.
7. The emission levels of other frequencies are very lower than the limit and not show in test report.

Product : Wireless Motherboard
 Test Item : Harmonic Radiated Emission Data
 Test Site : No.3 OATS
 Test Mode : Mode 2: Transmit (802.11n-20BW 14.4Mbps) (5180MHz)

Frequency MHz	Correct Factor dB	Reading Level dBuV	Measurement Level dBuV/m	Margin dB	Limit dBuV/m
Horizontal					
Peak Detector:					
10360.000	12.930	36.730	49.660	-24.340	74.000
15540.000	*	*	*	*	74.000
20720.000	*	*	*	*	74.000
25900.000	*	*	*	*	74.000
31080.000	*	*	*	*	74.000
36260.000	*	*	*	*	74.000
Average Detector:					
--					
Vertical					
Peak Detector:					
10360.000	13.724	36.370	50.094	-23.906	74.000
20720.000	*	*	*	*	74.000
25900.000	*	*	*	*	74.000
31080.000	*	*	*	*	74.000
36260.000	*	*	*	*	74.000
Average Detector:					
--					

Note:

1. All Readings below 1GHz are Quasi-Peak, above 1GHz are performed with peak and/or average measurements as necessary.
2. Peak measurements: RBW = 1MHz, VBW = 3 MHz, Sweep: Auto.
3. Average measurements: RBW = 1MHz, VBW = 10 Hz, Sweep: Auto.
4. Measurement Level = Reading Level + Correct Factor.
5. Correct Factor = Antenna factor + Cable loss – Amplifier gain.
6. The average measurement was not performed when the peak measured data under the limit of average detection.
7. The emission levels of other frequencies are very lower than the limit and not show in test report.

Product : Wireless Motherboard
 Test Item : Harmonic Radiated Emission Data
 Test Site : No.3 OATS
 Test Mode : Mode 2: Transmit (802.11n-20BW 14.4Mbps) (5220MHz)

Frequency MHz	Correct Factor dB	Reading Level dBuV	Measurement Level dBuV/m	Margin dB	Limit dBuV/m
Horizontal					
Peak Detector:					
10440.000	13.322	37.260	50.582	-23.418	74.000
15660.000	*	*	*	*	74.000
20880.000	*	*	*	*	74.000
26100.000	*	*	*	*	74.000
31320.000	*	*	*	*	74.000
36540.000	*	*	*	*	74.000
Average Detector:					
--					
Vertical					
Peak Detector:					
10440.000	14.245	36.230	50.475	-23.525	74.000
20880.000	*	*	*	*	74.000
26100.000	*	*	*	*	74.000
31320.000	*	*	*	*	74.000
36540.000	*	*	*	*	74.000
Average Detector:					
--					

Note:

1. All Readings below 1GHz are Quasi-Peak, above 1GHz are performed with peak and/or average measurements as necessary.
2. Peak measurements: RBW = 1MHz, VBW = 3 MHz, Sweep: Auto.
3. Average measurements: RBW = 1MHz, VBW = 10 Hz, Sweep: Auto.
4. Measurement Level = Reading Level + Correct Factor.
5. Correct Factor = Antenna factor + Cable loss – Amplifier gain.
6. The average measurement was not performed when the peak measured data under the limit of average detection.
7. The emission levels of other frequencies are very lower than the limit and not show in test report.

Product : Wireless Motherboard
 Test Item : Harmonic Radiated Emission Data
 Test Site : No.3 OATS
 Test Mode : Mode 2: Transmit (802.11n-20BW 14.4Mbps) (5240MHz)

Frequency MHz	Correct Factor dB	Reading Level dBuV	Measurement Level dBuV/m	Margin dB	Limit dBuV/m
Horizontal					
Peak Detector:					
10480.000	13.693	38.380	52.074	-21.926	74.000
15720.000	*	*	*	*	74.000
20960.000	*	*	*	*	74.000
26200.000	*	*	*	*	74.000
31440.000	*	*	*	*	74.000
36680.000	*	*	*	*	74.000
Average Detector:					
--					
Vertical					
Peak Detector:					
10480.000	14.620	36.070	50.691	-23.309	74.000
20960.000	*	*	*	*	74.000
26200.000	*	*	*	*	74.000
31440.000	*	*	*	*	74.000
36680.000	*	*	*	*	74.000
Average Detector:					
--					

Note:

1. All Readings below 1GHz are Quasi-Peak, above 1GHz are performed with peak and/or average measurements as necessary.
2. Peak measurements: RBW = 1MHz, VBW = 3 MHz, Sweep: Auto.
3. Average measurements: RBW = 1MHz, VBW = 10 Hz, Sweep: Auto.
4. Measurement Level = Reading Level + Correct Factor.
5. Correct Factor = Antenna factor + Cable loss – Amplifier gain.
6. The average measurement was not performed when the peak measured data under the limit of average detection.
7. The emission levels of other frequencies are very lower than the limit and not show in test report.

Product : Wireless Motherboard
 Test Item : Harmonic Radiated Emission Data
 Test Site : No.3 OATS
 Test Mode : Mode 2: Transmit (802.11n-20BW 14.4Mbps) (5260MHz)

Frequency MHz	Correct Factor dB	Reading Level dBuV	Measurement Level dBuV/m	Margin dB	Limit dBuV/m
Horizontal					
Peak Detector:					
10520.000	14.015	37.880	51.895	-22.105	74.000
15780.000	*	*	*	*	74.000
21040.000	*	*	*	*	74.000
26300.000	*	*	*	*	74.000
31560.000	*	*	*	*	74.000
36820.000	*	*	*	*	74.000
Average Detector:					
--					
Vertical					
Peak Detector:					
10520.000	14.818	38.750	53.568	-20.432	74.000
15780.000	*	*	*	*	74.000
21040.000	*	*	*	*	74.000
26300.000	*	*	*	*	74.000
31560.000	*	*	*	*	74.000
36820.000	*	*	*	*	74.000
Average Detector:					
--					

Note:

1. All Readings below 1GHz are Quasi-Peak, above 1GHz are performed with peak and/or average measurements as necessary.
2. Peak measurements: RBW = 1MHz, VBW = 3 MHz, Sweep: Auto.
3. Average measurements: RBW = 1MHz, VBW = 10 Hz, Sweep: Auto.
4. Measurement Level = Reading Level + Correct Factor.
5. Correct Factor = Antenna factor + Cable loss – Amplifier gain.
6. The average measurement was not performed when the peak measured data under the limit of average detection.
7. The emission levels of other frequencies are very lower than the limit and not show in test report.

Product : Wireless Motherboard
 Test Item : Harmonic Radiated Emission Data
 Test Site : No.3 OATS
 Test Mode : Mode 2: Transmit (802.11n-20BW 14.4Mbps) (5300MHz)

Frequency MHz	Correct Factor dB	Reading Level dBuV	Measurement Level dBuV/m	Margin dB	Limit dBuV/m
Horizontal					
Peak Detector:					
10600.000	14.550	37.500	52.049	-21.951	74.000
15900.000	*	*	*	*	74.000
21200.000	*	*	*	*	74.000
26500000	*	*	*	*	74.000
31800.000	*	*	*	*	74.000
37100.000	*	*	*	*	74.000
Average Detector:					
--					
Vertical					
Peak Detector:					
10600.000	14.881	41.170	56.051	-17.949	74.000
15900.000	*	*	*	*	74.000
21200.000	*	*	*	*	74.000
26500000	*	*	*	*	74.000
31800.000	*	*	*	*	74.000
37100.000	*	*	*	*	74.000
Average Detector:					
10600.000	14.881	26.080	40.961	-13.039	54.000

Note:

1. All Readings below 1GHz are Quasi-Peak, above 1GHz are performed with peak and/or average measurements as necessary.
2. Peak measurements: RBW = 1MHz, VBW = 3 MHz, Sweep: Auto.
3. Average measurements: RBW = 1MHz, VBW = 10 Hz, Sweep: Auto.
4. Measurement Level = Reading Level + Correct Factor.
5. Correct Factor = Antenna factor + Cable loss – Amplifier gain.
6. The average measurement was not performed when the peak measured data under the limit of average detection.
7. The emission levels of other frequencies are very lower than the limit and not show in test report.

Product : Wireless Motherboard
 Test Item : Harmonic Radiated Emission Data
 Test Site : No.3 OATS
 Test Mode : Mode 2: Transmit (802.11n-20BW 14.4Mbps) (5320MHz)

Frequency MHz	Correct Factor dB	Reading Level dBuV	Measurement Level dBuV/m	Margin dB	Limit dBuV/m
Horizontal					
Peak Detector:					
10640.000	14.690	38.410	53.100	-20.900	74.000
15960.000	*	*	*	*	74.000
21280.000	*	*	*	*	74.000
26600.000	*	*	*	*	74.000
31920.000	*	*	*	*	74.000
37240.000	*	*	*	*	74.000
Average Detector:					
--					
Vertical					
Peak Detector:					
10640.000	15.083	41.230	56.313	-17.687	74.000
15960.000	*	*	*	*	74.000
21280.000	*	*	*	*	74.000
26600.000	*	*	*	*	74.000
31920.000	*	*	*	*	74.000
37240.000	*	*	*	*	74.000
Average Detector:					
10640.000	15.083	26.540	41.623	-12.377	54.000

Note:

1. All Readings below 1GHz are Quasi-Peak, above 1GHz are performed with peak and/or average measurements as necessary.
2. Peak measurements: RBW = 1MHz, VBW = 3 MHz, Sweep: Auto.
3. Average measurements: RBW = 1MHz, VBW = 10 Hz, Sweep: Auto.
4. Measurement Level = Reading Level + Correct Factor.
5. Correct Factor = Antenna factor + Cable loss – Amplifier gain.
6. The average measurement was not performed when the peak measured data under the limit of average detection.
7. The emission levels of other frequencies are very lower than the limit and not show in test report.

Product : Wireless Motherboard
 Test Item : Harmonic Radiated Emission Data
 Test Site : No.3 OATS
 Test Mode : Mode 2: Transmit (802.11n-20BW 14.4Mbps) (5500MHz)

Frequency MHz	Correct Factor dB	Reading Level dBuV	Measurement Level dBuV/m	Margin dB	Limit dBuV/m
Horizontal					
Peak Detector:					
11000.000	16.399	41.160	57.559	-16.441	74.000
16500.000	*	*	*	*	74.000
22000.000	*	*	*	*	74.000
27500.000	*	*	*	*	74.000
33000.000	*	*	*	*	74.000
38500.000	*	*	*	*	74.000
Average Detector:					
11000.000	16.399	27.640	44.039	-9.961	54.000
Vertical					
Peak Detector:					
11000.000	17.132	42.860	59.992	-14.008	74.000
16500.000	*	*	*	*	74.000
22000.000	*	*	*	*	74.000
27500.000	*	*	*	*	74.000
33000.000	*	*	*	*	74.000
38500.000	*	*	*	*	74.000
Average Detector:					
11000.000	17.132	27.700	44.832	-9.168	54.000

Note:

1. All Readings below 1GHz are Quasi-Peak, above 1GHz are performed with peak and/or average measurements as necessary.
2. Peak measurements: RBW = 1MHz, VBW = 3 MHz, Sweep: Auto.
3. Average measurements: RBW = 1MHz, VBW = 10 Hz, Sweep: Auto.
4. Measurement Level = Reading Level + Correct Factor.
5. Correct Factor = Antenna factor + Cable loss – Amplifier gain.
6. The average measurement was not performed when the peak measured data under the limit of average detection.
7. The emission levels of other frequencies are very lower than the limit and not show in test report.

Product : Wireless Motherboard
 Test Item : Harmonic Radiated Emission Data
 Test Site : No.3 OATS
 Test Mode : Mode 2: Transmit (802.11n-20BW 14.4Mbps) (5580MHz)

Frequency MHz	Correct Factor dB	Reading Level dBuV	Measurement Level dBuV/m	Margin dB	Limit dBuV/m
Horizontal					
Peak Detector:					
11160.000	16.664	43.880	60.545	-13.455	74.000
16740.000	*	*	*	*	74.000
22320.000	*	*	*	*	74.000
27900.000	*	*	*	*	74.000
33480.000	*	*	*	*	74.000
39060.000	*	*	*	*	74.000
Average Detector:					
11160.000	16.664	29.310	45.975	-8.025	54.000
Vertical					
Peak Detector:					
11160.000	17.643	44.570	62.213	-11.787	74.000
16740.000	*	*	*	*	74.000
22320.000	*	*	*	*	74.000
27900.000	*	*	*	*	74.000
33480.000	*	*	*	*	74.000
39060.000	*	*	*	*	74.000
Average Detector:					
11160.000	17.643	29.460	47.103	-6.897	54.000

Note:

1. All Readings below 1GHz are Quasi-Peak, above 1GHz are performed with peak and/or average measurements as necessary.
2. Peak measurements: RBW = 1MHz, VBW = 3 MHz, Sweep: Auto.
3. Average measurements: RBW = 1MHz, VBW = 10 Hz, Sweep: Auto.
4. Measurement Level = Reading Level + Correct Factor.
5. Correct Factor = Antenna factor + Cable loss – Amplifier gain.
6. The average measurement was not performed when the peak measured data under the limit of average detection.
7. The emission levels of other frequencies are very lower than the limit and not show in test report.

Product : Wireless Motherboard
 Test Item : Harmonic Radiated Emission Data
 Test Site : No.3 OATS
 Test Mode : Mode 2: Transmit (802.11n-20BW 14.4Mbps) (5700MHz)

Frequency MHz	Correct Factor dB	Reading Level dBuV	Measurement Level dBuV/m	Margin dB	Limit dBuV/m
Horizontal					
Peak Detector:					
11400.000	16.530	43.390	59.921	-14.079	74.000
17100.000	*	*	*	*	74.000
22800.000	*	*	*	*	74.000
28500.000	*	*	*	*	74.000
34200.000	*	*	*	*	74.000
39900.000	*	*	*	*	74.000
Average Detector:					
11400.000	16.530	27.640	44.171	-9.829	54.000
Vertical					
Peak Detector:					
11400.000	17.138	43.940	61.078	-12.922	74.000
17100.000	*	*	*	*	74.000
22800.000	*	*	*	*	74.000
28500.000	*	*	*	*	74.000
34200.000	*	*	*	*	74.000
39900.000	*	*	*	*	74.000
Average Detector:					
11400.000	17.138	29.320	46.458	-7.542	54.000

Note:

1. All Readings below 1GHz are Quasi-Peak, above 1GHz are performed with peak and/or average measurements as necessary.
2. Peak measurements: RBW = 1MHz, VBW = 3 MHz, Sweep: Auto.
3. Average measurements: RBW = 1MHz, VBW = 10 Hz, Sweep: Auto.
4. Measurement Level = Reading Level + Correct Factor.
5. Correct Factor = Antenna factor + Cable loss – Amplifier gain.
6. The average measurement was not performed when the peak measured data under the limit of average detection.
7. The emission levels of other frequencies are very lower than the limit and not show in test report.

Product : Wireless Motherboard
 Test Item : Harmonic Radiated Emission Data
 Test Site : No.3 OATS
 Test Mode : Mode 3: Transmit (802.11n-40BW 30Mbps) (5190MHz)

Frequency MHz	Correct Factor dB	Reading Level dBuV	Measurement Level dBuV/m	Margin dB	Limit dBuV/m
Horizontal					
Peak Detector:					
10380.000	12.939	36.820	49.759	-24.241	74.000
15570.000	*	*	*	*	74.000
20760.000	*	*	*	*	74.000
25950.000	*	*	*	*	74.000
31140.000	*	*	*	*	74.000
36330.000	*	*	*	*	74.000
Average Detector:					
--					
Vertical					
Peak Detector:					
10380.000	13.796	37.600	51.396	-22.604	74.000
20760.000	*	*	*	*	74.000
25950.000	*	*	*	*	74.000
31140.000	*	*	*	*	74.000
36330.000	*	*	*	*	74.000
Average Detector:					
--					

Note:

1. All Readings below 1GHz are Quasi-Peak, above 1GHz are performed with peak and/or average measurements as necessary.
2. Peak measurements: RBW = 1MHz, VBW = 3 MHz, Sweep: Auto.
3. Average measurements: RBW = 1MHz, VBW = 10 Hz, Sweep: Auto.
4. Measurement Level = Reading Level + Correct Factor.
5. Correct Factor = Antenna factor + Cable loss – Amplifier gain.
6. The average measurement was not performed when the peak measured data under the limit of average detection.
7. The emission levels of other frequencies are very lower than the limit and not show in test report.

Product : Wireless Motherboard
 Test Item : Harmonic Radiated Emission Data
 Test Site : No.3 OATS
 Test Mode : Mode 3: Transmit (802.11n-40BW 30Mbps) (5230MHz)

Frequency MHz	Correct Factor dB	Reading Level dBuV	Measurement Level dBuV/m	Margin dB	Limit dBuV/m
Horizontal					
Peak Detector:					
10460.000	13.508	36.890	50.398	-23.602	74.000
15690.000	*	*	*	*	74.000
20920.000	*	*	*	*	74.000
26150.000	*	*	*	*	74.000
31380.000	*	*	*	*	74.000
36610.000	*	*	*	*	74.000
Average Detector:					
--					
Vertical					
Peak Detector:					
10460.000	14.433	37.430	51.863	-22.137	74.000
20920.000	*	*	*	*	74.000
26150.000	*	*	*	*	74.000
31380.000	*	*	*	*	74.000
36610.000	*	*	*	*	74.000
Average Detector:					
--					

Note:

1. All Readings below 1GHz are Quasi-Peak, above 1GHz are performed with peak and/or average measurements as necessary.
2. Peak measurements: RBW = 1MHz, VBW = 3 MHz, Sweep: Auto.
3. Average measurements: RBW = 1MHz, VBW = 10 Hz, Sweep: Auto.
4. Measurement Level = Reading Level + Correct Factor.
5. Correct Factor = Antenna factor + Cable loss – Amplifier gain.
6. The average measurement was not performed when the peak measured data under the limit of average detection.
7. The emission levels of other frequencies are very lower than the limit and not show in test report.

Product : Wireless Motherboard
 Test Item : Harmonic Radiated Emission Data
 Test Site : No.3 OATS
 Test Mode : Mode 3: Transmit (802.11n-40BW 30Mbps) (5270MHz)

Frequency MHz	Correct Factor dB	Reading Level dBuV	Measurement Level dBuV/m	Margin dB	Limit dBuV/m
Horizontal					
Peak Detector:					
10540.000	14.151	36.190	50.340	-23.660	74.000
15810.000	*	*	*	*	74.000
21080.000	*	*	*	*	74.000
26350.000	*	*	*	*	74.000
31620.000	*	*	*	*	74.000
36890.000	*	*	*	*	74.000
Average Detector:					
--					
Vertical					
Peak Detector:					
10540.000	14.829	36.120	50.948	-23.052	74.000
15810.000	*	*	*	*	74.000
21080.000	*	*	*	*	74.000
26350.000	*	*	*	*	74.000
31620.000	*	*	*	*	74.000
36890.000	*	*	*	*	74.000
Average Detector:					
--					

Note:

1. All Readings below 1GHz are Quasi-Peak, above 1GHz are performed with peak and/or average measurements as necessary.
2. Peak measurements: RBW = 1MHz, VBW = 3 MHz, Sweep: Auto.
3. Average measurements: RBW = 1MHz, VBW = 10 Hz, Sweep: Auto.
4. Measurement Level = Reading Level + Correct Factor.
5. Correct Factor = Antenna factor + Cable loss – Amplifier gain.
6. The average measurement was not performed when the peak measured data under the limit of average detection.
7. The emission levels of other frequencies are very lower than the limit and not show in test report.

Product : Wireless Motherboard
 Test Item : Harmonic Radiated Emission Data
 Test Site : No.3 OATS
 Test Mode : Mode 3: Transmit (802.11n-40BW 30Mbps) (5310MHz)

Frequency MHz	Correct Factor dB	Reading Level dBuV	Measurement Level dBuV/m	Margin dB	Limit dBuV/m
Horizontal					
Peak Detector:					
10620.000	14.623	36.670	51.293	-22.707	74.000
15930.000	*	*	*	*	74.000
21240.000	*	*	*	*	74.000
26550.000	*	*	*	*	74.000
31860.000	*	*	*	*	74.000
37170.000	*	*	*	*	74.000
Average Detector:					
--					
Vertical					
Peak Detector:					
10620.000	14.970	38.110	53.080	-20.920	74.000
15930.000	*	*	*	*	74.000
21240.000	*	*	*	*	74.000
26550.000	*	*	*	*	74.000
31860.000	*	*	*	*	74.000
37170.000	*	*	*	*	74.000
Average Detector:					
--					

Note:

1. All Readings below 1GHz are Quasi-Peak, above 1GHz are performed with peak and/or average measurements as necessary.
2. Peak measurements: RBW = 1MHz, VBW = 3 MHz, Sweep: Auto.
3. Average measurements: RBW = 1MHz, VBW = 10 Hz, Sweep: Auto.
4. Measurement Level = Reading Level + Correct Factor.
5. Correct Factor = Antenna factor + Cable loss – Amplifier gain.
6. The average measurement was not performed when the peak measured data under the limit of average detection.
7. The emission levels of other frequencies are very lower than the limit and not show in test report.

Product : Wireless Motherboard
 Test Item : Harmonic Radiated Emission Data
 Test Site : No.3 OATS
 Test Mode : Mode 3: Transmit (802.11n-40BW 30Mbps) (5510MHz)

Frequency MHz	Correct Factor dB	Reading Level dBuV	Measurement Level dBuV/m	Margin dB	Limit dBuV/m
Horizontal					
Peak Detector:					
11020.000	16.474	37.010	53.483	-20.517	74.000
15930.000	*	*	*	*	74.000
21240.000	*	*	*	*	74.000
26550.000	*	*	*	*	74.000
31860.000	*	*	*	*	74.000
37170.000	*	*	*	*	74.000
Average Detector:					
--					
Vertical					
Peak Detector:					
11020.000	17.224	40.290	57.514	-16.486	74.000
15930.000	*	*	*	*	74.000
21240.000	*	*	*	*	74.000
26550.000	*	*	*	*	74.000
31860.000	*	*	*	*	74.000
37170.000	*	*	*	*	74.000
Average Detector:					
11020.000	17.224	22.210	39.434	-14.566	54.000

Note:

1. All Readings below 1GHz are Quasi-Peak, above 1GHz are performed with peak and/or average measurements as necessary.
2. Peak measurements: RBW = 1MHz, VBW = 3 MHz, Sweep: Auto.
3. Average measurements: RBW = 1MHz, VBW = 10 Hz, Sweep: Auto.
4. Measurement Level = Reading Level + Correct Factor.
5. Correct Factor = Antenna factor + Cable loss – Amplifier gain.
6. The average measurement was not performed when the peak measured data under the limit of average detection.
7. The emission levels of other frequencies are very lower than the limit and not show in test report.

Product : Wireless Motherboard
 Test Item : Harmonic Radiated Emission Data
 Test Site : No.3 OATS
 Test Mode : Mode 3: Transmit (802.11n-40BW 30Mbps) (5550MHz)

Frequency MHz	Correct Factor dB	Reading Level dBuV	Measurement Level dBuV/m	Margin dB	Limit dBuV/m
Horizontal					
Peak Detector:					
11100.000	16.681	38.960	55.641	-18.359	74.000
15930.000	*	*	*	*	74.000
21240.000	*	*	*	*	74.000
26550.000	*	*	*	*	74.000
31860.000	*	*	*	*	74.000
37170.000	*	*	*	*	74.000
Average Detector:					
11100.000	16.681	24.810	41.491	-12.509	54.000
Vertical					
Peak Detector:					
11100.000	17.523	42.200	59.723	-14.277	74.000
15930.000	*	*	*	*	74.000
21240.000	*	*	*	*	74.000
26550.000	*	*	*	*	74.000
31860.000	*	*	*	*	74.000
37170.000	*	*	*	*	74.000
Average Detector:					
11100.000	17.523	26.470	43.993	-10.007	54.000

Note:

1. All Readings below 1GHz are Quasi-Peak, above 1GHz are performed with peak and/or average measurements as necessary.
2. Peak measurements: RBW = 1MHz, VBW = 3 MHz, Sweep: Auto.
3. Average measurements: RBW = 1MHz, VBW = 10 Hz, Sweep: Auto.
4. Measurement Level = Reading Level + Correct Factor.
5. Correct Factor = Antenna factor + Cable loss – Amplifier gain.
6. The average measurement was not performed when the peak measured data under the limit of average detection.
7. The emission levels of other frequencies are very lower than the limit and not show in test report.

Product : Wireless Motherboard
 Test Item : Harmonic Radiated Emission Data
 Test Site : No.3 OATS
 Test Mode : Mode 3: Transmit (802.11n-40BW 30Mbps) (5670MHz)

Frequency MHz	Correct Factor dB	Reading Level dBuV	Measurement Level dBuV/m	Margin dB	Limit dBuV/m
Horizontal					
Peak Detector:					
11340.000	16.408	41.070	57.477	-16.523	74.000
15930.000	*	*	*	*	74.000
21240.000	*	*	*	*	74.000
26550.000	*	*	*	*	74.000
31860.000	*	*	*	*	74.000
37170.000	*	*	*	*	74.000
Average Detector:					
11340.000	16.408	25.670	42.077	-11.923	54.000
Vertical					
Peak Detector:					
11340.000	17.167	41.430	58.597	-15.403	74.000
15930.000	*	*	*	*	74.000
21240.000	*	*	*	*	74.000
26550.000	*	*	*	*	74.000
31860.000	*	*	*	*	74.000
37170.000	*	*	*	*	74.000
Average Detector:					
11340.000	17.167	25.980	43.147	-10.853	54.000

Note:

1. All Readings below 1GHz are Quasi-Peak, above 1GHz are performed with peak and/or average measurements as necessary.
2. Peak measurements: RBW = 1MHz, VBW = 3 MHz, Sweep: Auto.
3. Average measurements: RBW = 1MHz, VBW = 10 Hz, Sweep: Auto.
4. Measurement Level = Reading Level + Correct Factor.
5. Correct Factor = Antenna factor + Cable loss – Amplifier gain.
6. The average measurement was not performed when the peak measured data under the limit of average detection.
7. The emission levels of other frequencies are very lower than the limit and not show in test report.

Product : Wireless Motherboard
 Test Item : General Radiated Emission
 Test Site : No.3 OATS
 Test Mode : Mode 1: Transmit (802.11a-6Mbps) (5220MHz) (Chip Antenna)

Frequency MHz	Correct Factor dB	Reading Level dBuV	Measurement Level dBuV/m	Margin dB	Limit dBuV/m
Horizontal					
Peak Detector					
119.240	-9.621	42.108	32.487	-11.013	43.500
187.140	-11.377	37.663	26.286	-17.214	43.500
291.900	-4.174	35.687	31.512	-14.488	46.000
381.140	-0.988	40.680	39.692	-6.308	46.000
516.940	1.654	36.189	37.843	-8.157	46.000
604.240	4.770	34.720	39.490	-6.510	46.000
Vertical					
Peak Detector					
111.480	-0.954	32.494	31.540	-11.960	43.500
210.420	-7.882	35.613	27.732	-15.768	43.500
305.480	-6.809	43.560	36.751	-9.249	46.000
418.000	-8.544	34.104	25.560	-20.440	46.000
540.220	0.121	26.965	27.086	-18.914	46.000
840.920	2.961	32.286	35.247	-10.753	46.000

Note:

1. All Readings below 1GHz are Quasi-Peak, above 1GHz are performed with peak and/or average measurements as necessary.
2. Peak measurements: RBW = 1MHz, VBW = 3 MHz, Sweep: Auto.
3. Average measurements: RBW = 1MHz, VBW = 10 Hz, Sweep: Auto.
4. Measurement Level = Reading Level + Correct Factor.
5. Correct Factor = Antenna factor + Cable loss – Amplifier gain.
6. The average measurement was not performed when the peak measured data under the limit of average detection.
7. The emission levels of other frequencies are very lower than the limit and not show in test report.
8. No emission found between lowest internal used/generated frequency to 30MHz.

Product : Wireless Motherboard
 Test Item : General Radiated Emission
 Test Site : No.3 OATS
 Test Mode : Mode 1: Transmit (802.11a-6Mbps) (5300MHz) (Chip Antenna)

Frequency MHz	Correct Factor dB	Reading Level dBuV	Measurement Level dBuV/m	Margin dB	Limit dBuV/m
Horizontal					
Peak Detector					
159.980	-11.775	40.298	28.523	-14.977	43.500
282.200	-5.211	36.475	31.264	-14.736	46.000
386.960	-1.524	38.935	37.411	-8.589	46.000
460.680	1.589	36.675	38.264	-7.736	46.000
582.900	3.445	31.613	35.058	-10.942	46.000
743.920	3.326	32.733	36.059	-9.941	46.000
Vertical					
Peak Detector					
109.540	-0.418	33.297	32.879	-10.621	43.500
225.940	-8.598	36.540	27.941	-18.059	46.000
334.580	-4.891	39.281	34.390	-11.610	46.000
507.240	-0.471	24.829	24.358	-21.642	46.000
685.720	2.319	23.550	25.868	-20.132	46.000
807.940	3.586	31.216	34.801	-11.199	46.000

Note:

1. All Readings below 1GHz are Quasi-Peak, above 1GHz are performed with peak and/or average measurements as necessary.
2. Peak measurements: RBW = 1MHz, VBW = 3 MHz, Sweep: Auto.
3. Average measurements: RBW = 1MHz, VBW = 10 Hz, Sweep: Auto.
4. Measurement Level = Reading Level + Correct Factor.
5. Correct Factor = Antenna factor + Cable loss – Amplifier gain.
6. The average measurement was not performed when the peak measured data under the limit of average detection.
7. The emission levels of other frequencies are very lower than the limit and not show in test report.
8. No emission found between lowest internal used/generated frequency to 30MHz.

Product : Wireless Motherboard
 Test Item : General Radiated Emission
 Test Site : No.3 OATS
 Test Mode : Mode 1: Transmit (802.11a-6Mbps) (5580MHz) (Chip Antenna)

Frequency MHz	Correct Factor dB	Reading Level dBuV	Measurement Level dBuV/m	Margin dB	Limit dBuV/m
Horizontal					
Peak Detector					
130.880	-10.159	41.427	31.268	-12.232	43.500
241.460	-6.531	42.510	35.979	-10.021	46.000
324.880	-4.491	31.603	27.112	-18.888	46.000
398.600	-2.268	32.241	29.973	-16.027	46.000
505.300	0.308	37.055	37.363	-8.637	46.000
724.520	3.485	33.018	36.503	-9.497	46.000
Vertical					
Peak Detector					
111.480	-0.954	32.154	31.200	-12.300	43.500
249.220	-7.634	33.546	25.912	-20.088	46.000
353.980	-3.652	32.344	28.692	-17.308	46.000
468.440	-4.725	32.449	27.724	-18.276	46.000
596.480	-3.113	26.947	23.834	-22.166	46.000
844.800	3.181	29.719	32.900	-13.100	46.000

Note:

1. All Readings below 1GHz are Quasi-Peak, above 1GHz are performed with peak and/or average measurements as necessary.
2. Peak measurements: RBW = 1MHz, VBW = 3 MHz, Sweep: Auto.
3. Average measurements: RBW = 1MHz, VBW = 10 Hz, Sweep: Auto.
4. Measurement Level = Reading Level + Correct Factor.
5. Correct Factor = Antenna factor + Cable loss – Amplifier gain.
6. The average measurement was not performed when the peak measured data under the limit of average detection.
7. The emission levels of other frequencies are very lower than the limit and not show in test report.
8. No emission found between lowest internal used/generated frequency to 30MHz.

Product : Wireless Motherboard
 Test Item : General Radiated Emission
 Test Site : No.3 OATS
 Test Mode : Mode 1: Transmit (802.11a-6Mbps) (5220MHz) (PIFA Antenna)

Frequency MHz	Correct Factor dB	Reading Level dBuV	Measurement Level dBuV/m	Margin dB	Limit dBuV/m
Horizontal					
Peak Detector					
161.920	-11.626	47.213	35.588	-7.912	43.500
392.780	-2.096	36.327	34.231	-11.769	46.000
483.960	-0.688	36.919	36.232	-9.768	46.000
600.360	3.977	33.950	37.927	-8.073	46.000
712.880	3.569	27.806	31.375	-14.625	46.000
961.200	6.450	43.499	49.949	-4.051	54.000
Vertical					
Peak Detector					
111.480	-0.954	35.740	34.786	-8.714	43.500
181.320	-9.512	44.271	34.759	-8.741	43.500
222.060	-8.789	43.212	34.423	-11.577	46.000
286.080	-8.097	45.106	37.009	-8.991	46.000
365.620	-2.179	34.574	32.395	-13.605	46.000
747.800	2.166	30.672	32.838	-13.162	46.000

Note:

1. All Readings below 1GHz are Quasi-Peak, above 1GHz are performed with peak and/or average measurements as necessary.
2. Peak measurements: RBW = 1MHz, VBW = 3 MHz, Sweep: Auto.
3. Average measurements: RBW = 1MHz, VBW = 10 Hz, Sweep: Auto.
4. Measurement Level = Reading Level + Correct Factor.
5. Correct Factor = Antenna factor + Cable loss – Amplifier gain.
6. The average measurement was not performed when the peak measured data under the limit of average detection.
7. The emission levels of other frequencies are very lower than the limit and not show in test report.
8. No emission found between lowest internal used/generated frequency to 30MHz.

Product : Wireless Motherboard
 Test Item : General Radiated Emission
 Test Site : No.3 OATS
 Test Mode : Mode 1: Transmit (802.11a-6Mbps) (5300MHz) (PIFA Antenna)

Frequency MHz	Correct Factor dB	Reading Level dBuV	Measurement Level dBuV/m	Margin dB	Limit dBuV/m
Horizontal					
Peak Detector					
222.060	-10.439	45.017	34.578	-11.422	46.000
505.300	0.308	31.268	31.576	-14.424	46.000
664.380	2.062	29.952	32.014	-13.986	46.000
747.800	3.296	29.620	32.916	-13.084	46.000
858.380	5.972	31.844	37.816	-8.184	46.000
961.200	6.450	43.202	49.652	-4.348	54.000

Vertical					
Peak Detector					
101.780	-0.021	34.656	34.634	-8.866	43.500
171.620	-8.752	41.884	33.132	-10.368	43.500
229.820	-8.512	44.640	36.128	-9.872	46.000
363.680	-2.393	37.978	35.585	-10.415	46.000
480.080	-4.359	32.641	28.282	-17.718	46.000
961.200	7.260	33.483	40.743	-13.257	54.000

Note:

1. All Readings below 1GHz are Quasi-Peak, above 1GHz are performed with peak and/or average measurements as necessary.
2. Peak measurements: RBW = 1MHz, VBW = 3 MHz, Sweep: Auto.
3. Average measurements: RBW = 1MHz, VBW = 10 Hz, Sweep: Auto.
4. Measurement Level = Reading Level + Correct Factor.
5. Correct Factor = Antenna factor + Cable loss – Amplifier gain.
6. The average measurement was not performed when the peak measured data under the limit of average detection.
7. The emission levels of other frequencies are very lower than the limit and not show in test report.
8. No emission found between lowest internal used/generated frequency to 30MHz.

Product : Wireless Motherboard
 Test Item : General Radiated Emission
 Test Site : No.3 OATS
 Test Mode : Mode 1: Transmit (802.11a-6Mbps) (5580MHz) (PIFA Antenna)

Frequency MHz	Correct Factor dB	Reading Level dBuV	Measurement Level dBuV/m	Margin dB	Limit dBuV/m
Horizontal					
Peak Detector					
152.220	-10.135	41.859	31.724	-11.776	43.500
402.480	-2.263	33.788	31.525	-14.475	46.000
513.060	1.550	30.172	31.722	-14.278	46.000
625.580	1.770	28.788	30.558	-15.442	46.000
697.360	3.171	27.379	30.550	-15.450	46.000
961.200	6.450	43.013	49.463	-4.537	54.000
Vertical					
Peak Detector					
134.760	-4.648	37.232	32.584	-10.916	43.500
355.920	-3.488	38.783	35.295	-10.705	46.000
480.080	-4.359	36.246	31.887	-14.113	46.000
600.360	-2.833	29.121	26.288	-19.712	46.000
747.800	2.166	29.746	31.912	-14.088	46.000
961.200	7.260	36.865	44.125	-9.875	54.000

Note:

1. All Readings below 1GHz are Quasi-Peak, above 1GHz are performed with peak and/or average measurements as necessary.
2. Peak measurements: RBW = 1MHz, VBW = 3 MHz, Sweep: Auto.
3. Average measurements: RBW = 1MHz, VBW = 10 Hz, Sweep: Auto.
4. Measurement Level = Reading Level + Correct Factor.
5. Correct Factor = Antenna factor + Cable loss – Amplifier gain.
6. The average measurement was not performed when the peak measured data under the limit of average detection.
7. The emission levels of other frequencies are very lower than the limit and not show in test report.
8. No emission found between lowest internal used/generated frequency to 30MHz.

Product : Wireless Motherboard
 Test Item : General Radiated Emission
 Test Site : No.3 OATS
 Test Mode : Mode 2: Transmit (802.11n-20BW 14.4Mbps) (5220MHz)

Frequency MHz	Correct Factor dB	Reading Level dBuV	Measurement Level dBuV/m	Margin dB	Limit dBuV/m
Horizontal					
Peak Detector					
121.180	-9.834	41.613	31.779	-11.721	43.500
243.400	-6.441	43.019	36.578	-9.422	46.000
336.520	-3.860	39.474	35.614	-10.386	46.000
402.480	-2.263	39.667	37.404	-8.596	46.000
515.000	1.610	35.250	36.860	-9.140	46.000
817.640	5.532	28.799	34.331	-11.669	46.000
Vertical					
Peak Detector					
136.700	-5.143	37.566	32.423	-11.077	43.500
270.560	-9.247	38.162	28.915	-17.085	46.000
375.320	-2.029	37.149	35.120	-10.880	46.000
497.540	-1.393	30.679	29.286	-16.714	46.000
584.840	-5.839	32.512	26.673	-19.327	46.000
844.800	3.181	30.532	33.713	-12.287	46.000

Note:

1. All Readings below 1GHz are Quasi-Peak, above 1GHz are performed with peak and/or average measurements as necessary.
2. Peak measurements: RBW = 1MHz, VBW = 3 MHz, Sweep: Auto.
3. Average measurements: RBW = 1MHz, VBW = 10 Hz, Sweep: Auto.
4. Measurement Level = Reading Level + Correct Factor.
5. Correct Factor = Antenna factor + Cable loss – Amplifier gain.
6. The average measurement was not performed when the peak measured data under the limit of average detection.
7. The emission levels of other frequencies are very lower than the limit and not show in test report.
8. No emission found between lowest internal used/generated frequency to 30MHz.

Product : Wireless Motherboard
 Test Item : General Radiated Emission
 Test Site : No.3 OATS
 Test Mode : Mode 2: Transmit (802.11n-20BW 14.4Mbps) (5300MHz)

Frequency MHz	Correct Factor dB	Reading Level dBuV	Measurement Level dBuV/m	Margin dB	Limit dBuV/m
Horizontal					
Peak Detector					
115.360	-8.770	43.263	34.493	-9.007	43.500
239.520	-6.851	41.224	34.374	-11.626	46.000
322.940	-4.442	41.644	37.202	-8.798	46.000
390.840	-1.849	37.474	35.625	-10.375	46.000
528.580	1.848	34.906	36.754	-9.246	46.000
804.060	5.027	33.708	38.735	-7.265	46.000
Vertical					
Peak Detector					
158.040	-6.191	35.905	29.714	-13.786	43.500
295.780	-7.455	41.503	34.048	-11.952	46.000
392.780	-3.536	32.551	29.015	-16.985	46.000
538.280	0.020	29.200	29.220	-16.780	46.000
687.660	2.444	25.213	27.657	-18.343	46.000
840.920	2.961	30.780	33.741	-12.259	46.000

Note:

1. All Readings below 1GHz are Quasi-Peak, above 1GHz are performed with peak and/or average measurements as necessary.
2. Peak measurements: RBW = 1MHz, VBW = 3 MHz, Sweep: Auto.
3. Average measurements: RBW = 1MHz, VBW = 10 Hz, Sweep: Auto.
4. Measurement Level = Reading Level + Correct Factor.
5. Correct Factor = Antenna factor + Cable loss – Amplifier gain.
6. The average measurement was not performed when the peak measured data under the limit of average detection.
7. The emission levels of other frequencies are very lower than the limit and not show in test report.
8. No emission found between lowest internal used/generated frequency to 30MHz.

Product : Wireless Motherboard
 Test Item : General Radiated Emission
 Test Site : No.3 OATS
 Test Mode : Mode 2: Transmit (802.11n-20BW 14.4Mbps) (5580MHz)

Frequency MHz	Correct Factor dB	Reading Level dBuV	Measurement Level dBuV/m	Margin dB	Limit dBuV/m
Horizontal					
Peak Detector					
357.860	-2.084	35.843	33.759	-12.241	46.000
445.160	-3.112	39.163	36.051	-9.949	46.000
546.040	3.570	28.880	32.449	-13.551	46.000
631.400	1.605	32.414	34.019	-11.981	46.000
759.440	4.372	27.563	31.935	-14.065	46.000
916.580	6.144	31.995	38.139	-7.861	46.000
Vertical					
Peak Detector					
140.580	-6.241	38.193	31.952	-11.548	43.500
297.720	-7.143	34.518	27.376	-18.624	46.000
433.520	-9.082	36.545	27.463	-18.537	46.000
542.160	-0.269	26.483	26.214	-19.786	46.000
683.780	1.968	30.668	32.636	-13.364	46.000
833.160	2.263	35.347	37.610	-8.390	46.000

Note:

1. All Readings below 1GHz are Quasi-Peak, above 1GHz are performed with peak and/or average measurements as necessary.
2. Peak measurements: RBW = 1MHz, VBW = 3 MHz, Sweep: Auto.
3. Average measurements: RBW = 1MHz, VBW = 10 Hz, Sweep: Auto.
4. Measurement Level = Reading Level + Correct Factor.
5. Correct Factor = Antenna factor + Cable loss – Amplifier gain.
6. The average measurement was not performed when the peak measured data under the limit of average detection.
7. The emission levels of other frequencies are very lower than the limit and not show in test report.
8. No emission found between lowest internal used/generated frequency to 30MHz.

Product : Wireless Motherboard
 Test Item : General Radiated Emission
 Test Site : No.3 OATS
 Test Mode : Mode 3: Transmit (802.11n-40BW 30Mbps) (5190MHz)

Frequency MHz	Correct Factor dB	Reading Level dBuV	Measurement Level dBuV/m	Margin dB	Limit dBuV/m
Horizontal					
Peak Detector					
136.700	-10.363	43.821	33.458	-10.042	43.500
243.400	-6.441	44.754	38.313	-7.687	46.000
303.540	-3.074	43.251	40.177	-5.823	46.000
466.500	0.794	39.303	40.096	-5.904	46.000
551.860	2.714	36.030	38.744	-7.256	46.000
804.060	5.027	35.360	40.387	-5.613	46.000
Vertical					
Peak Detector					
119.240	-3.541	33.633	30.092	-13.408	43.500
235.640	-9.330	41.080	31.750	-14.250	46.000
330.700	-4.912	27.026	22.114	-23.886	46.000
462.620	-3.838	41.197	37.359	-8.641	46.000
600.360	-2.833	35.826	32.993	-13.007	46.000
807.940	3.586	29.452	33.037	-12.963	46.000

Note:

1. All Readings below 1GHz are Quasi-Peak, above 1GHz are performed with peak and/or average measurements as necessary.
2. Peak measurements: RBW = 1MHz, VBW = 3 MHz, Sweep: Auto.
3. Average measurements: RBW = 1MHz, VBW = 10 Hz, Sweep: Auto.
4. Measurement Level = Reading Level + Correct Factor.
5. Correct Factor = Antenna factor + Cable loss – Amplifier gain.
6. The average measurement was not performed when the peak measured data under the limit of average detection.
7. The emission levels of other frequencies are very lower than the limit and not show in test report.
8. No emission found between lowest internal used/generated frequency to 30MHz.

Product : Wireless Motherboard
 Test Item : General Radiated Emission
 Test Site : No.3 OATS
 Test Mode : Mode 3: Transmit (802.11n-40BW 30Mbps) (5270MHz)

Frequency MHz	Correct Factor dB	Reading Level dBuV	Measurement Level dBuV/m	Margin dB	Limit dBuV/m
Horizontal					
Peak Detector					
41.640	-3.949	37.674	33.725	-6.275	40.000
291.900	-4.174	38.052	33.877	-12.123	46.000
381.140	-0.988	32.128	31.140	-14.860	46.000
505.300	0.308	32.708	33.016	-12.984	46.000
703.180	2.649	28.464	31.112	-14.888	46.000
817.640	5.532	25.601	31.133	-14.867	46.000
Vertical					
Peak Detector					
159.980	-6.185	35.392	29.207	-14.293	43.500
379.200	-1.505	26.108	24.602	-21.398	46.000
456.800	-4.697	34.380	29.683	-16.317	46.000
600.360	-2.833	35.159	32.326	-13.674	46.000
720.640	-0.099	24.992	24.893	-21.107	46.000
842.860	3.074	29.015	32.089	-13.911	46.000

Note:

1. All Readings below 1GHz are Quasi-Peak, above 1GHz are performed with peak and/or average measurements as necessary.
2. Peak measurements: RBW = 1MHz, VBW = 3 MHz, Sweep: Auto.
3. Average measurements: RBW = 1MHz, VBW = 10 Hz, Sweep: Auto.
4. Measurement Level = Reading Level + Correct Factor.
5. Correct Factor = Antenna factor + Cable loss – Amplifier gain.
6. The average measurement was not performed when the peak measured data under the limit of average detection.
7. The emission levels of other frequencies are very lower than the limit and not show in test report.
8. No emission found between lowest internal used/generated frequency to 30MHz.

Product : Wireless Motherboard
 Test Item : General Radiated Emission
 Test Site : No.3 OATS
 Test Mode : Mode 3: Transmit (802.11n-40BW 30Mbps) (5550MHz)

Frequency MHz	Correct Factor dB	Reading Level dBuV	Measurement Level dBuV/m	Margin dB	Limit dBuV/m
Horizontal					
Peak Detector					
243.400	-6.441	38.859	32.418	-13.582	46.000
456.800	-0.067	34.783	34.716	-11.284	46.000
600.360	3.977	37.403	41.380	-4.620	46.000
691.540	3.681	25.958	29.639	-16.361	46.000
811.820	5.081	25.498	30.578	-15.422	46.000
908.820	6.029	24.416	30.445	-15.555	46.000
Vertical					
Peak Detector					
167.740	-8.239	39.572	31.333	-12.167	43.500
328.760	-5.099	38.053	32.954	-13.046	46.000
381.140	-1.558	38.370	36.812	-9.188	46.000
551.860	-3.666	32.889	29.223	-16.777	46.000
689.600	2.538	29.368	31.906	-14.094	46.000
840.920	2.961	30.949	33.910	-12.090	46.000

Note:

1. All Readings below 1GHz are Quasi-Peak, above 1GHz are performed with peak and/or average measurements as necessary.
2. Peak measurements: RBW = 1MHz, VBW = 3 MHz, Sweep: Auto.
3. Average measurements: RBW = 1MHz, VBW = 10 Hz, Sweep: Auto.
4. Measurement Level = Reading Level + Correct Factor.
5. Correct Factor = Antenna factor + Cable loss – Amplifier gain.
6. The average measurement was not performed when the peak measured data under the limit of average detection.
7. The emission levels of other frequencies are very lower than the limit and not show in test report.
8. No emission found between lowest internal used/generated frequency to 30MHz.

7. Band Edge

7.1. Test Equipment

RF Conducted Measurement

The following test equipments are used during the band edge tests:

	Equipment	Manufacturer	Model No./Serial No.	Last Cal.
	Spectrum Analyzer	R&S	FSP40 / 100170	Jun, 2013
	Spectrum Analyzer	Agilent	E4407B / US39440758	Jun, 2013
X	Spectrum Analyzer	Agilent	N9010A / MY48030495	Apr., 2014

Note:

1. All equipments are calibrated with traceable calibrations. Each calibration is traceable to the national or international standards.
2. The test instruments marked with “X” are used to measure the final test results.

RF Radiated Measurement:

The following test equipments are used during the band edge tests:

Test Site	Equipment	Manufacturer	Model No./Serial No.	Last Cal.
☒ Site # 3	Bilog Antenna	Schaffner Chase	CBL6112B/2673	Sep., 2013
	X Horn Antenna	Schwarzbeck	BBHA9120D/D305	Sep., 2013
	Horn Antenna	Schwarzbeck	BBHA9170/208	Jul., 2013
	Pre-Amplifier	QTK	QTK-AMP-03 / 0003	May, 2013
	X Pre-Amplifier	QTK	AP-180C / CHM_0906076	Sep., 2013
	Pre-Amplifier	MITEQ	AMF-4D-180400-45-6P/ 925975	Mar, 2014
	X Spectrum Analyzer	Agilent	E4407B / US39440758	May, 2013
	Test Receiver	R & S	ESCS 30/ 825442/018	Sep., 2013
	X Coaxial Cable	Quietek	QTK-CABLE/ CAB5	Feb., 2014
	X Controller	Quietek	QTK-CONTROLLER/ CTRL3	N/A
	X Coaxial Switch	Anritsu	MP59B/6200265729	N/A

- Note:
1. All instruments are calibrated every one year.
 2. The test instruments marked by “X” are used to measure the final test results.

7.2. Test Setup

RF Conducted Measurement:

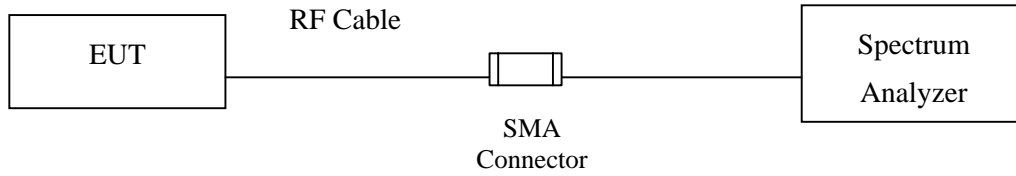

RF Radiated Measurement:

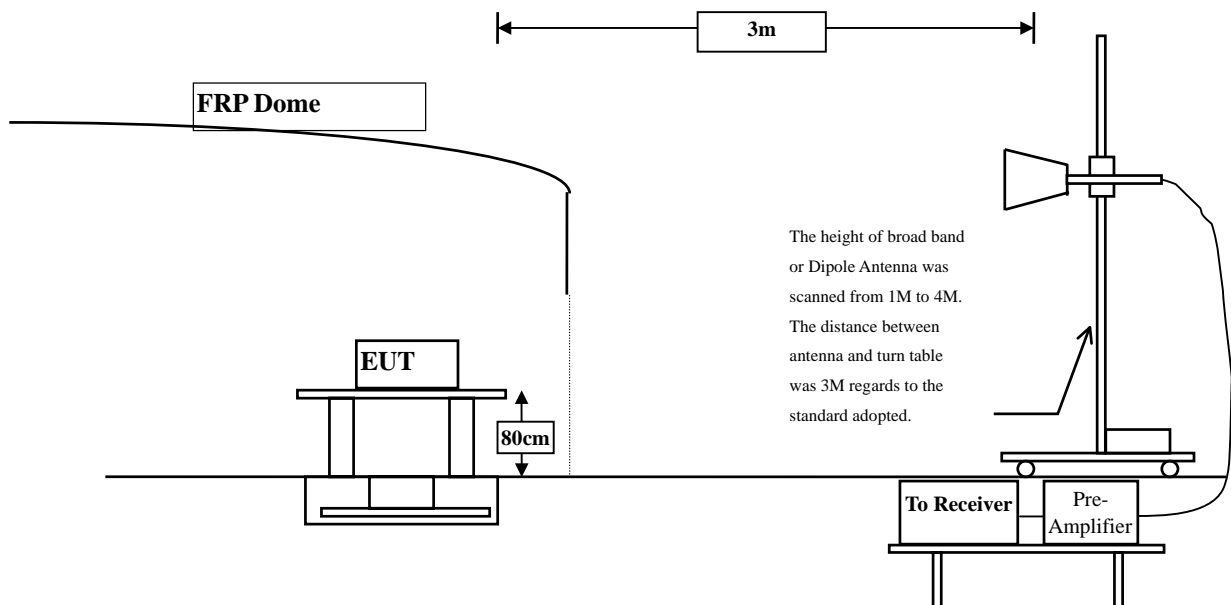

7.3. Limits

The provisions of Section 15.205 of this part apply to intentional radiators operating under this section.

Radiated emissions which fall in the restricted bands, as defined in Section 15.205, must also comply with the radiated emission limits specified in Section 15.209:

FCC Part 15 Subpart C Paragraph 15.209 Limits		
Frequency MHz	uV/m @3m	dBuV/m@3m
30-88	100	40
88-216	150	43.5
216-960	200	46
Above 960	500	54

- Remarks :
1. RF Voltage (dBuV) = 20 log RF Voltage (uV)
 2. In the Above Table, the tighter limit applies at the band edges.
 3. Distance refers to the distance in meters between the measuring instrument antenna and the closed point of any part of the device or system.

7.4. Test Procedure

The EUT and its simulators are placed on a turn table which is 0.8 meter above ground. The turn table can rotate 360 degrees to determine the position of the maximum emission level. The EUT was positioned such that the distance from antenna to the EUT was 3 meters.

The antenna can move up and down between 1 meter and 4 meters to find out the maximum emission level.

Both horizontal and vertical polarization of the antenna are set on measurement. In order to find the maximum emission, all of the interface cables must be manipulated according to ANSI C63.10:2009 on radiated measurement.

The bandwidth below 1GHz setting on the field strength meter is 120 kHz, above 1GHz are 1 MHz. The EUT was setup to ANSI C63.10, 2009; tested to DTS test procedure of FCC KDB-789033 for compliance to FCC 47CFR Subpart E requirements.

7.5. Uncertainty

- ± 3.8 dB below 1GHz
- ± 3.9 dB above 1GHz

7.6. Test Result of Band Edge

Product : Wireless Motherboard
 Test Item : Band Edge Data
 Test Site : No.3 OATS
 Test Mode : Mode 1: Transmit (802.11 a-6Mbps)-Channel 36 (Chip Antenna)

RF Radiated Measurement (Horizontal):

Channel No.	Frequency (MHz)	Correct Factor (dB)	Reading Level (dBuV)	Emission Level (dBuV/m)	Peak Limit (dBuV/m)	Average Limit (dBuV/m)	Result
36 (Peak)	5143.400	3.363	65.053	68.416	74.00	54.00	Pass
36 (Peak)	5150.000	3.340	64.226	67.566	74.00	54.00	Pass
36 (Peak)	5184.200	3.220	106.016	109.235	--	--	--
36 (Average)	5150.000	3.340	46.965	50.305	74.00	54.00	Pass
36 (Average)	5176.400	3.248	92.781	96.028	--	--	--

Figure Channel 36: Horizontal (Peak)

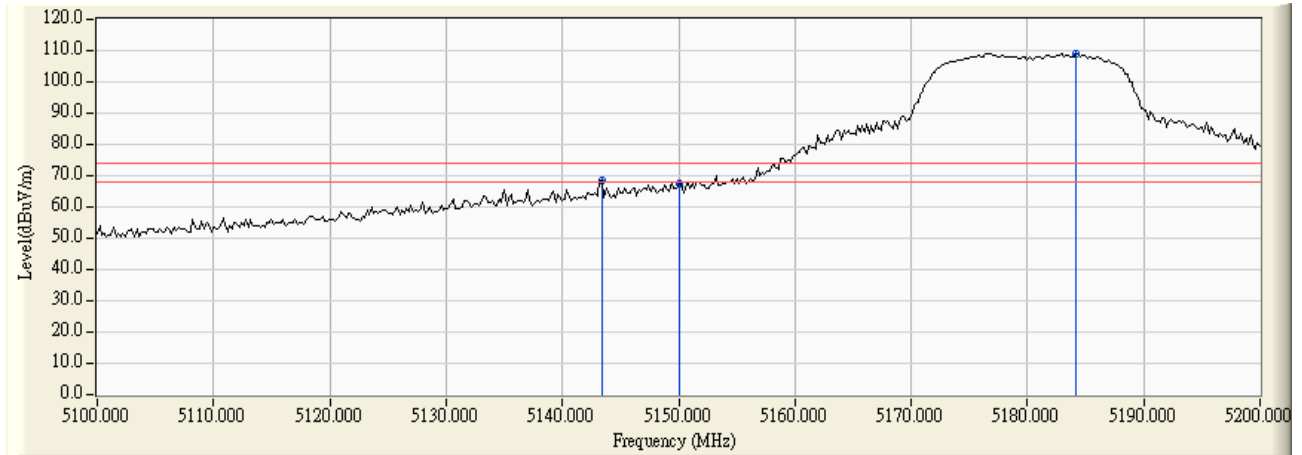
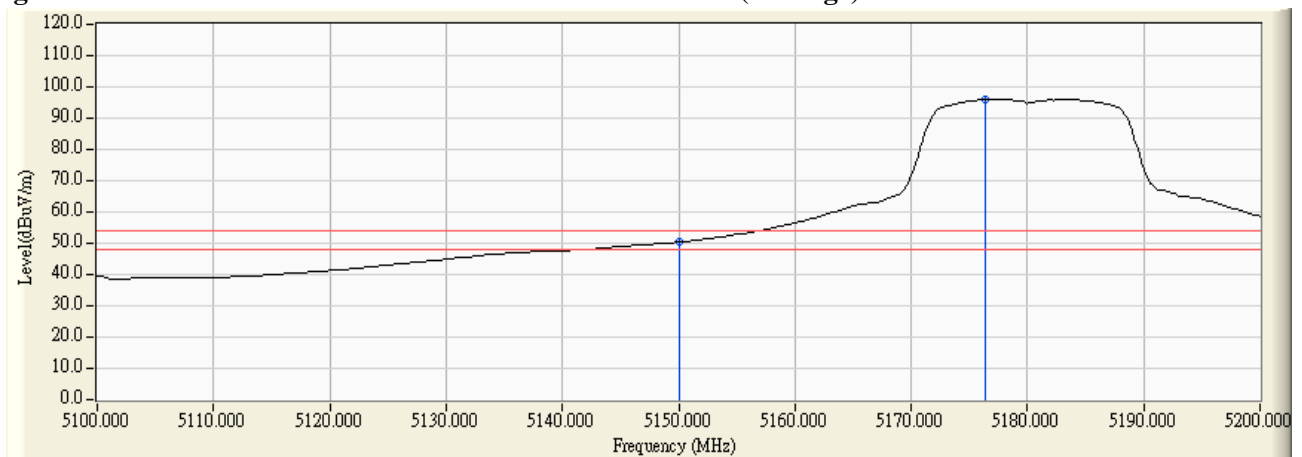

Figure Channel 36: Horizontal (Average)



- Note: 1. All readings above 1GHz are performed with peak and/or average measurements as necessary.
 2. Peak measurements: RBW = 1MHz, VBW = 3 MHz, Sweep: Auto.
 3. Average measurements: RBW = 1MHz, VBW = 10 Hz, Sweep: Auto.
 4. “ * ”, means this data is the worst emission level.
 5. Measurement Level = Reading Level + Correct Factor.
 6. The average measurement was not performed when the peak measured data under the limit of average detection.

Product : Wireless Motherboard
 Test Item : Band Edge Data
 Test Site : No.3 OATS
 Test Mode : Mode 1: Transmit (802.11a-6Mbps)-Channel 36 (Chip Antenna)

RF Radiated Measurement (Vertical):

Channel No.	Frequency (MHz)	Correct Factor (dB)	Reading Level (dBuV)	Emission Level (dBuV/m)	Peak Limit (dBuV/m)	Average Limit (dBuV/m)	Result
36 (Peak)	5145.000	5.246	64.951	70.197	74.00	54.00	Pass
36 (Peak)	5150.000	5.260	61.747	67.007	74.00	54.00	Pass
36 (Peak)	5177.600	5.336	104.130	109.465	--	--	--
36 (Average)	5150.000	5.260	45.160	50.420	74.00	54.00	Pass
36 (Average)	5176.600	5.333	91.010	96.343	--	--	--

Figure Channel 36: Vertical (Peak)

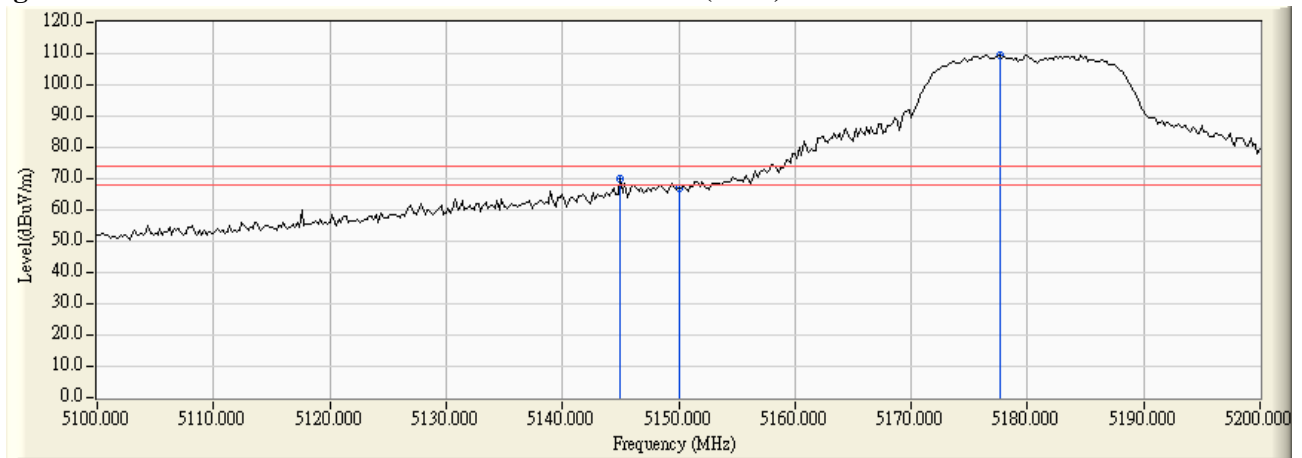
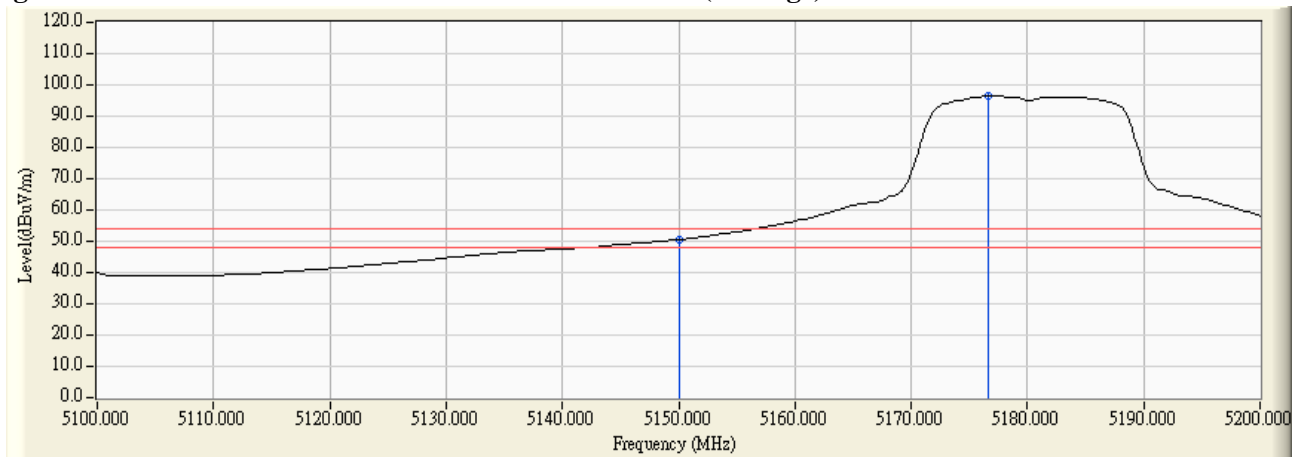

Figure Channel 36: Vertical (Average)



Note:

1. All readings above 1GHz are performed with peak and/or average measurements as necessary.
2. Peak measurements: RBW = 1MHz, VBW = 3 MHz, Sweep: Auto.
3. Average measurements: RBW = 1MHz, VBW = 10 Hz, Sweep: Auto.
4. “ * ”, means this data is the worst emission level.
5. Measurement Level = Reading Level + Correct Factor.
6. The average measurement was not performed when the peak measured data under the limit of average detection.

Product : Wireless Motherboard
 Test Item : Band Edge Data
 Test Site : No.3 OATS
 Test Mode : Mode 1: Transmit (802.11a-6Mbps) -Channel 64 (Chip Antenna)

RF Radiated Measurement (Horizontal):

Channel No.	Frequency (MHz)	Correct Factor (dB)	Reading Level (dBuV)	Emission Level (dBuV/m)	Peak Limit (dBuV/m)	Average Limit (dBuV/m)	Result
64 (Peak)	5316.800	3.823	105.206	109.028	--	--	--
64 (Peak)	5350.000	3.716	64.927	68.644	74.00	54.00	Pass
64 (Peak)	5350.600	3.714	65.768	69.483	74.00	54.00	Pass
64 (Average)	5316.400	3.823	91.912	95.736	--	--	--
64 (Average)	5350.000	3.716	45.595	49.312	74.00	54.00	Pass

Figure Channel 64: Horizontal (Peak)

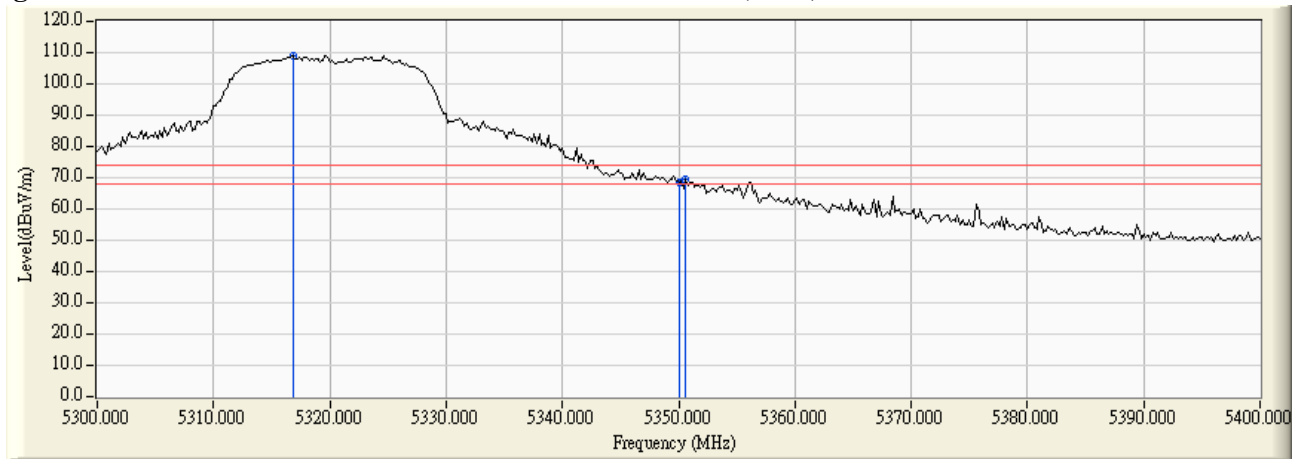
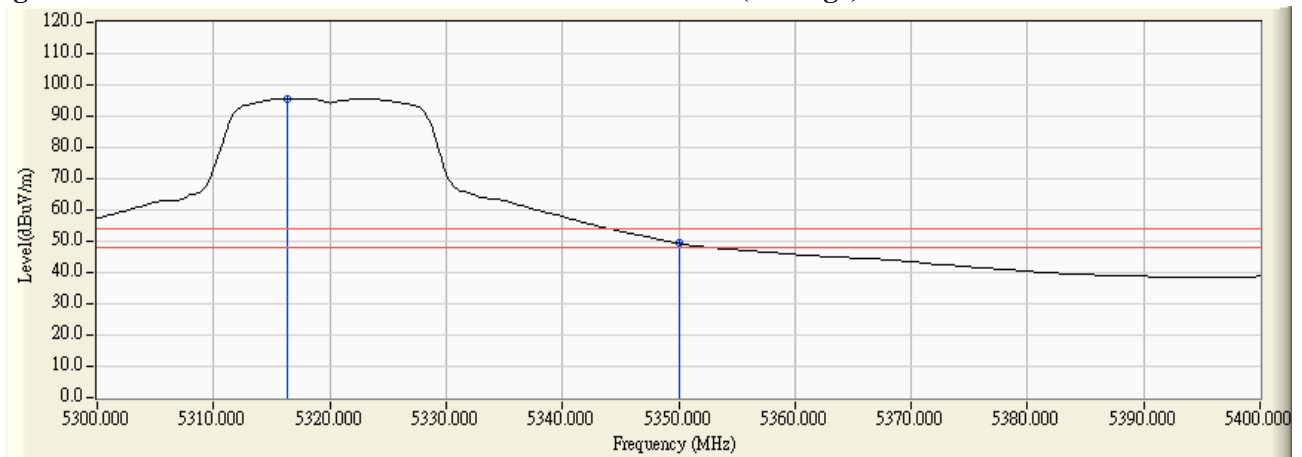

Figure Channel 64: Horizontal (Average)



Note:

1. All readings above 1GHz are performed with peak and/or average measurements as necessary.
2. Peak measurements: RBW = 1MHz, VBW = 3 MHz, Sweep: Auto.
3. Average measurements: RBW = 1MHz, VBW = 10 Hz, Sweep: Auto.
4. “ * ”, means this data is the worst emission level.
5. Measurement Level = Reading Level + Correct Factor.
6. The average measurement was not performed when the peak measured data under the limit of average detection.

Product : Wireless Motherboard
 Test Item : Band Edge Data
 Test Site : No.3 OATS
 Test Mode : Mode 1: Transmit (802.11a-6Mbps) -Channel 64 (Chip Antenna)

RF Radiated Measurement (Vertical):

Channel No.	Frequency (MHz)	Correct Factor (dB)	Reading Level (dBuV)	Emission Level (dBuV/m)	Peak Limit (dBuV/m)	Average Limit (dBuV/m)	Result
64 (Peak)	5317.600	5.732	103.629	109.361	--	--	--
64 (Peak)	5350.000	5.691	62.476	68.168	74.00	54.00	Pass
64 (Peak)	5350.400	5.690	65.528	71.219	74.00	54.00	Pass
64 (Average)	5316.000	5.733	90.071	95.805	--	--	--
64 (Average)	5350.000	5.691	43.619	49.311	74.00	54.00	Pass

Figure Channel 64: Vertical (Peak)

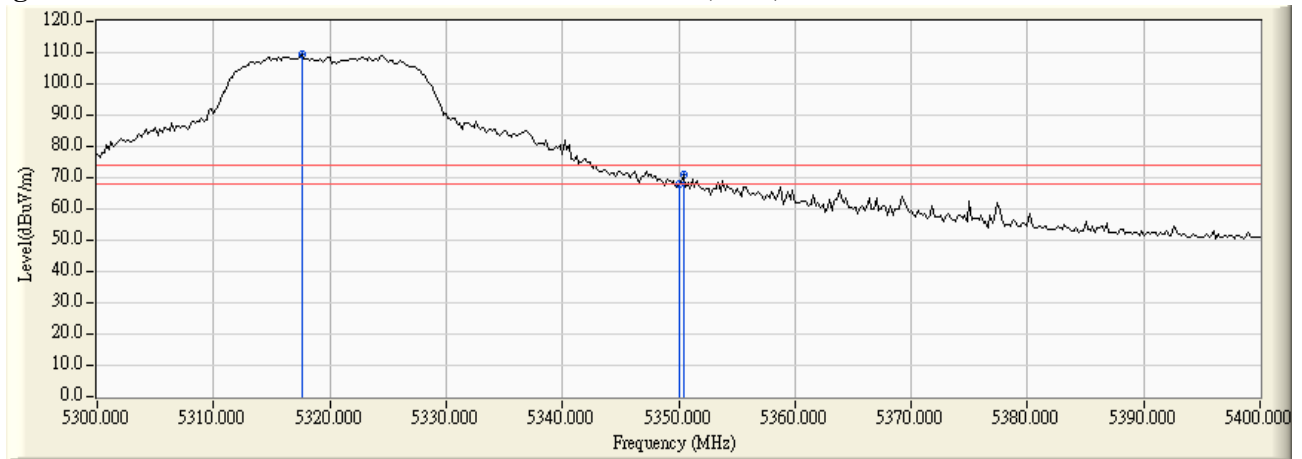
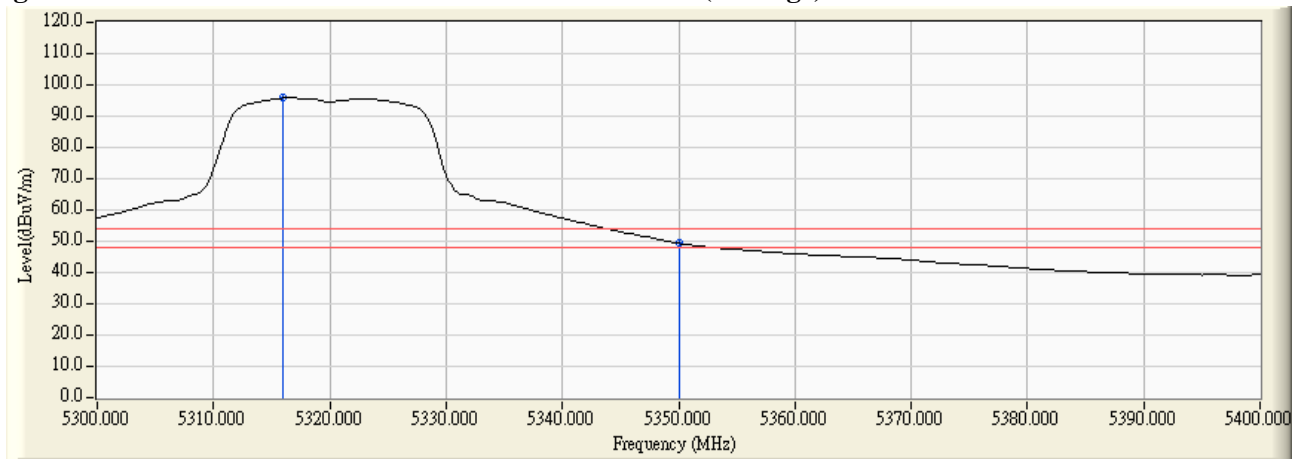

Figure Channel 64: Vertical (Average)



Note:

1. All readings above 1GHz are performed with peak and/or average measurements as necessary.
2. Peak measurements: RBW = 1MHz, VBW = 3 MHz, Sweep: Auto.
3. Average measurements: RBW = 1MHz, VBW = 10 Hz, Sweep: Auto.
4. “ * ”, means this data is the worst emission level.
5. Measurement Level = Reading Level + Correct Factor.
6. The average measurement was not performed when the peak measured data under the limit of average detection.

Product : Wireless Motherboard
 Test Item : Band Edge Data
 Test Site : No.3 OATS
 Test Mode : Mode 1: Transmit (802.11a-6Mbps) -Channel 100 (Chip Antenna)

RF Radiated Measurement (Horizontal):

Channel No.	Frequency (MHz)	Correct Factor (dB)	Reading Level (dBuV)	Emission Level (dBuV/m)	Peak Limit (dBuV/m)	Average Limit (dBuV/m)	Result
100 (Peak)	5459.400	4.347	66.618	70.964	74.00	54.00	Pass
100 (Peak)	5460.000	4.354	62.769	67.123	74.00	54.00	Pass
100 (Peak)	5504.600	4.847	105.310	110.156	--	--	--
100 (Average)	5460.000	4.354	43.772	48.126	74.00	54.00	Pass
100 (Average)	5497.000	4.794	91.968	96.762	--	--	--

Figure Channel 100: Horizontal (Peak)

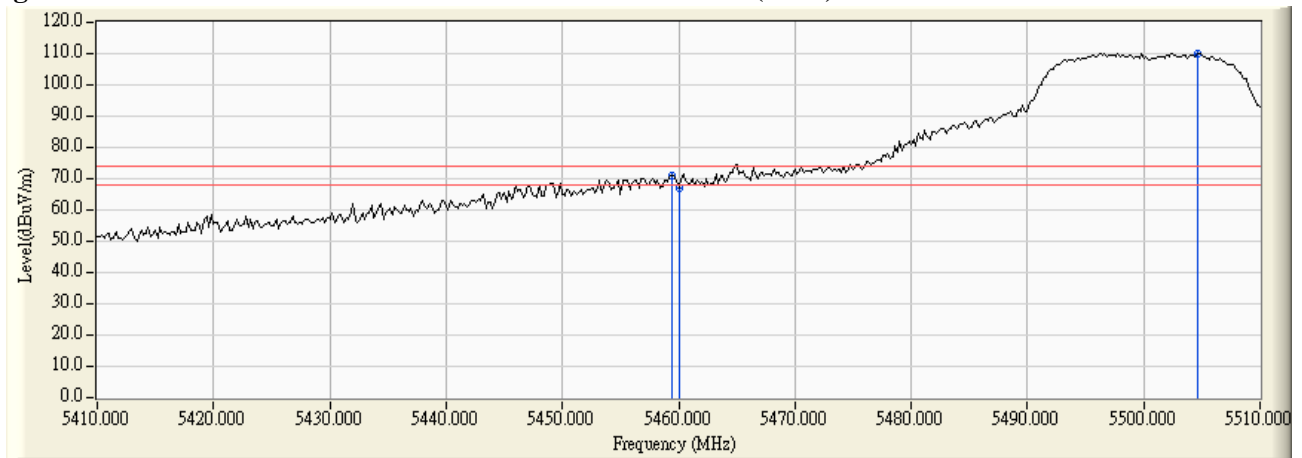
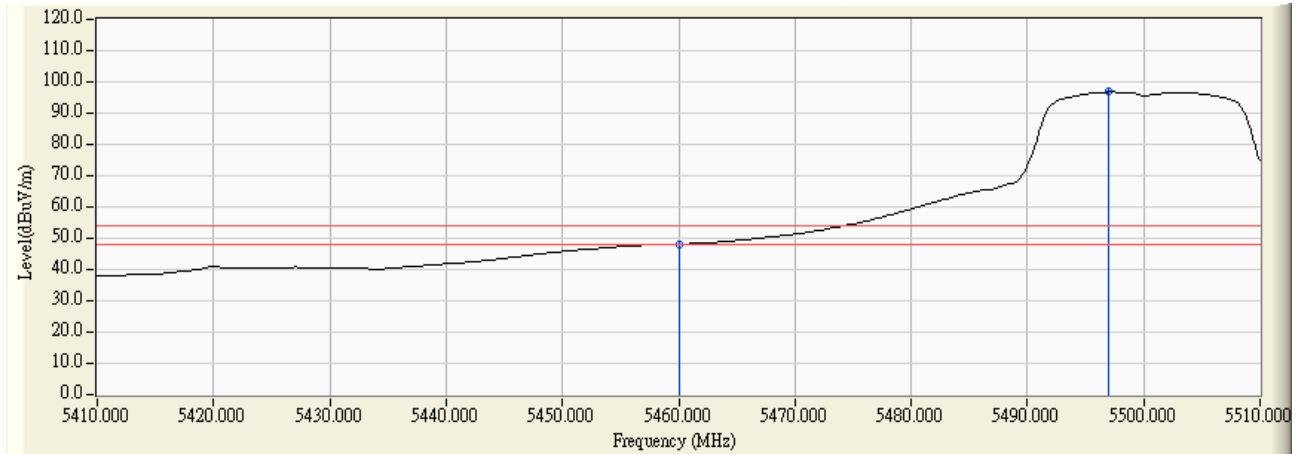

Figure Channel 100: Horizontal (Average)



Note:

1. All readings above 1GHz are performed with peak and/or average measurements as necessary.
2. Peak measurements: RBW = 1MHz, VBW = 3 MHz, Sweep: Auto.
3. Average measurements: RBW = 1MHz, VBW = 10 Hz, Sweep: Auto.
4. “*” , means this data is the worst emission level.
5. Measurement Level = Reading Level + Correct Factor.
6. The average measurement was not performed when the peak measured data under the limit of average detection.

Product : Wireless Motherboard
 Test Item : Band Edge Data
 Test Site : No.3 OATS
 Test Mode : Mode 1: Transmit (802.11a-6Mbps) -Channel 100 (Chip Antenna)

RF Radiated Measurement (Vertical):

Channel No.	Frequency (MHz)	Correct Factor (dB)	Reading Level (dBuV)	Emission Level (dBuV/m)	Peak Limit (dBuV/m)	Average Limit (dBuV/m)	Result
100 (Peak)	5458.400	6.029	62.930	68.960	74.00	54.00	Pass
100 (Peak)	5460.000	6.041	58.750	64.791	74.00	54.00	Pass
100 (Peak)	5498.000	6.268	101.320	107.589	--	--	--
100 (Average)	5460.000	6.041	40.824	46.865	74.00	54.00	Pass
100 (Average)	5496.400	6.264	88.223	94.487	--	--	--

Figure Channel 100: Vertical (Peak)

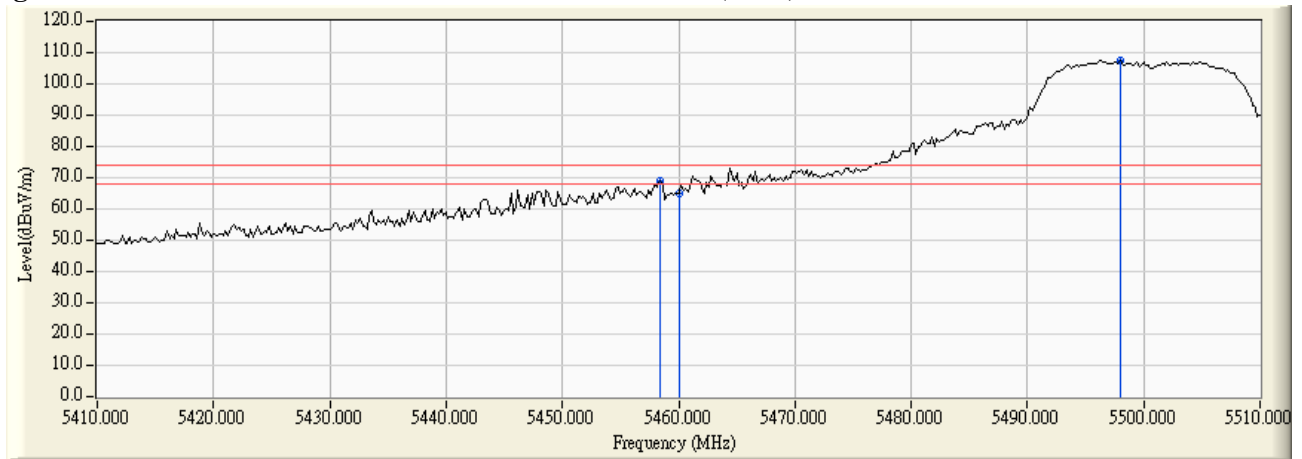
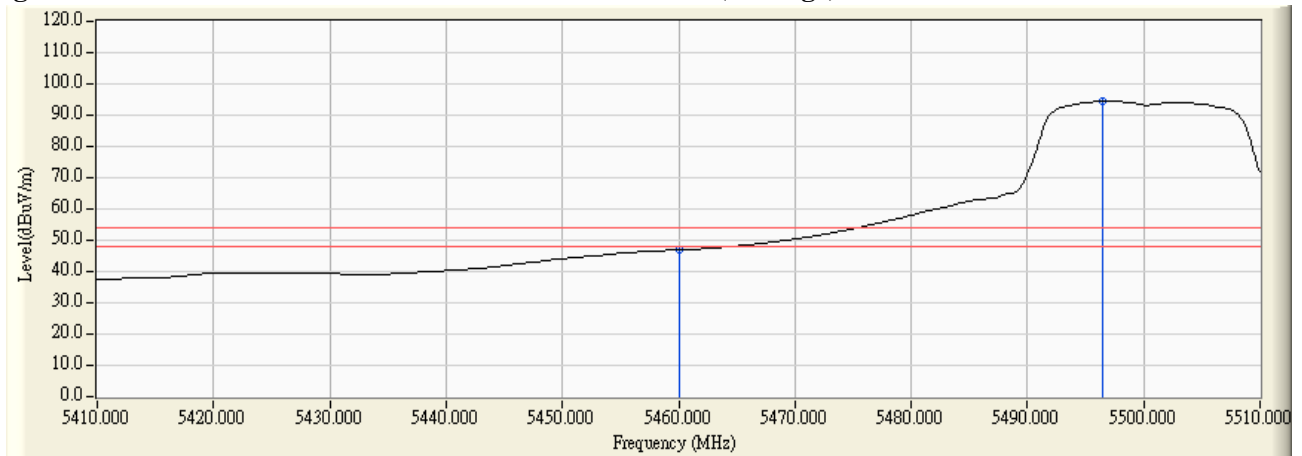

Figure Channel 100: Vertical (Average)



Note:

1. All readings above 1GHz are performed with peak and/or average measurements as necessary.
2. Peak measurements: RBW = 1MHz, VBW = 3 MHz, Sweep: Auto.
3. Average measurements: RBW = 1MHz, VBW = 10 Hz, Sweep: Auto.
4. “ * ”, means this data is the worst emission level.
5. Measurement Level = Reading Level + Correct Factor.
6. The average measurement was not performed when the peak measured data under the limit of average detection.

Product : Wireless Motherboard
 Test Item : Band Edge Data
 Test Site : No.3 OATS
 Test Mode : Mode 1: Transmit (802.11a-6Mbps) -Channel 100 (Chip Antenna)

RF Radiated Measurement:

	Frequency (MHz)	Correct Factor (dB)	Reading Level (dBm)	Measure Level (dBm/m)	Margin (dB)	Limit (dBm/m)	Result
Horizontal	5470.000	14.189	-78.970	-64.781	-37.781	-27.000	Pass

	Frequency (MHz)	Correct Factor (dB)	Reading Level (dBm)	Measure Level (dBm/m)	Margin (dB)	Limit (dBm/m)	Result
Vertical	5470.000	13.630	-76.750	-63.120	-36.120	-27.000	Pass

Product : Wireless Motherboard
 Test Item : Band Edge Data
 Test Site : No.3 OATS
 Test Mode : Mode 1: Transmit (802.11a-6Mbps) -Channel 140 (Chip Antenna)

RF Radiated Measurement:

	Frequency (MHz)	Correct Factor (dB)	Reading Level (dBm)	Measure Level (dBm/m)	Margin (dB)	Limit (dBm/m)	Result
Horizontal	5725.000	14.557	-78.520	-63.963	-36.963	-27.000	Pass

	Frequency (MHz)	Correct Factor (dB)	Reading Level (dBm)	Measure Level (dBm/m)	Margin (dB)	Limit (dBm/m)	Result
Vertical	5725.000	14.292	-77.070	-62.778	-35.778	-27.000	Pass

Product : Wireless Motherboard
 Test Item : Band Edge Data
 Test Site : No.3 OATS
 Test Mode : Mode 1: Transmit (802.11a-6Mbps)-Channel 36 (PIFA Antenna)

RF Radiated Measurement (Horizontal):

Channel No.	Frequency (MHz)	Correct Factor (dB)	Reading Level (dBuV)	Emission Level (dBuV/m)	Peak Limit (dBuV/m)	Average Limit (dBuV/m)	Result
36 (Peak)	5144.000	3.361	53.460	56.821	74.00	54.00	Pass
36 (Peak)	5150.000	3.340	51.614	54.954	74.00	54.00	Pass
36 (Peak)	5183.200	3.223	97.035	100.258	--	--	--
36 (Average)	5150.000	3.340	36.748	40.088	74.00	54.00	Pass
36 (Average)	5176.400	3.248	83.860	87.107	--	--	--

Figure Channel 36: Horizontal (Peak)

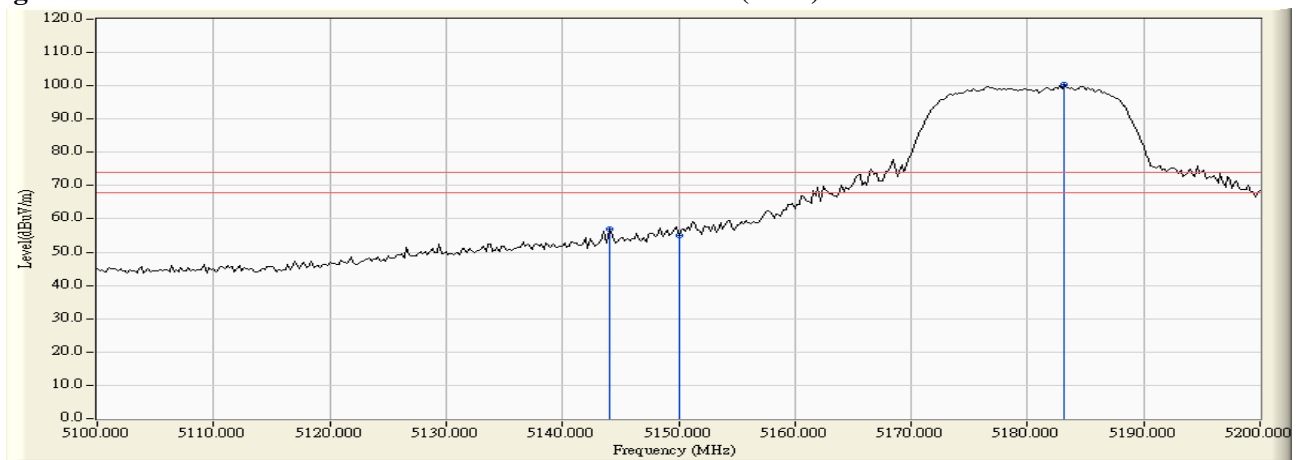
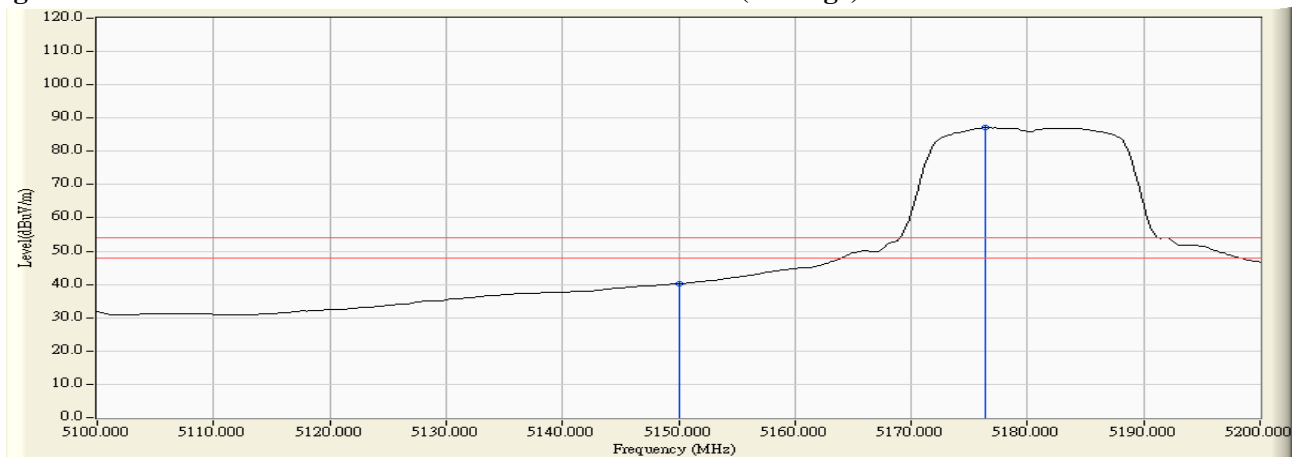

Figure Channel 36: Horizontal (Average)



- Note: 1. All readings above 1GHz are performed with peak and/or average measurements as necessary.
 2. Peak measurements: RBW = 1MHz, VBW = 3 MHz, Sweep: Auto.
 3. Average measurements: RBW = 1MHz, VBW = 10 Hz, Sweep: Auto.
 4. “ * ”, means this data is the worst emission level.
 5. Measurement Level = Reading Level + Correct Factor.
 6. The average measurement was not performed when the peak measured data under the limit of average detection.

Product : Wireless Motherboard
 Test Item : Band Edge Data
 Test Site : No.3 OATS
 Test Mode : Mode 1: Transmit (802.11a-6Mbps)-Channel 36 (PIFA Antenna)

RF Radiated Measurement (Vertical):

Channel No.	Frequency (MHz)	Correct Factor (dB)	Reading Level (dBuV)	Emission Level (dBuV/m)	Peak Limit (dBuV/m)	Average Limit (dBuV/m)	Result
36 (Peak)	5147.400	5.253	54.375	59.628	74.00	54.00	Pass
36 (Peak)	5150.000	5.260	51.890	57.150	74.00	54.00	Pass
36 (Peak)	5184.800	5.355	96.361	101.716	--	--	--
36 (Average)	5150.000	5.260	36.434	41.694	74.00	54.00	Pass
36 (Average)	5176.600	5.333	83.554	88.887	--	--	--

Figure Channel 36: Vertical (Peak)

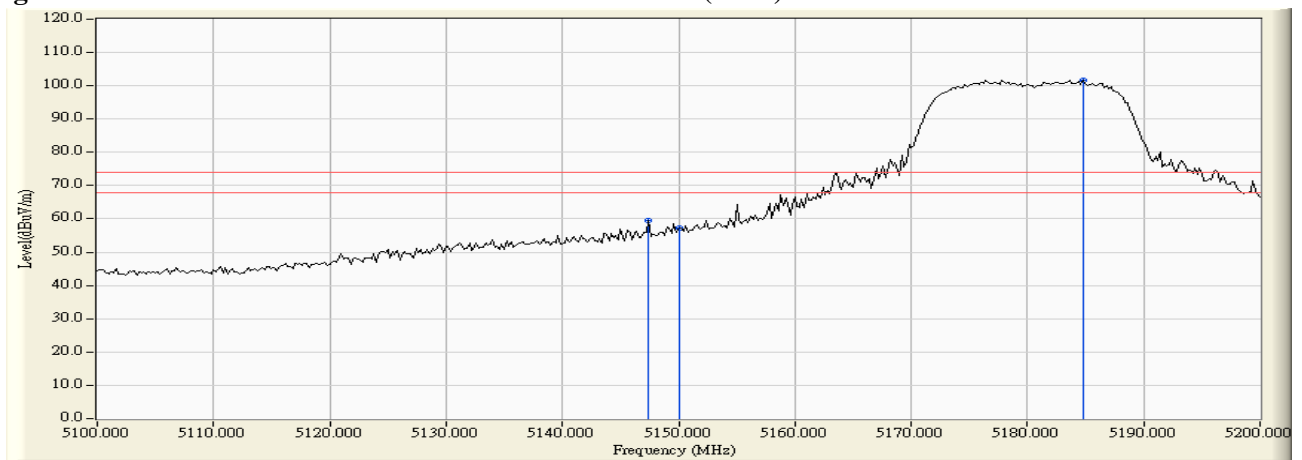
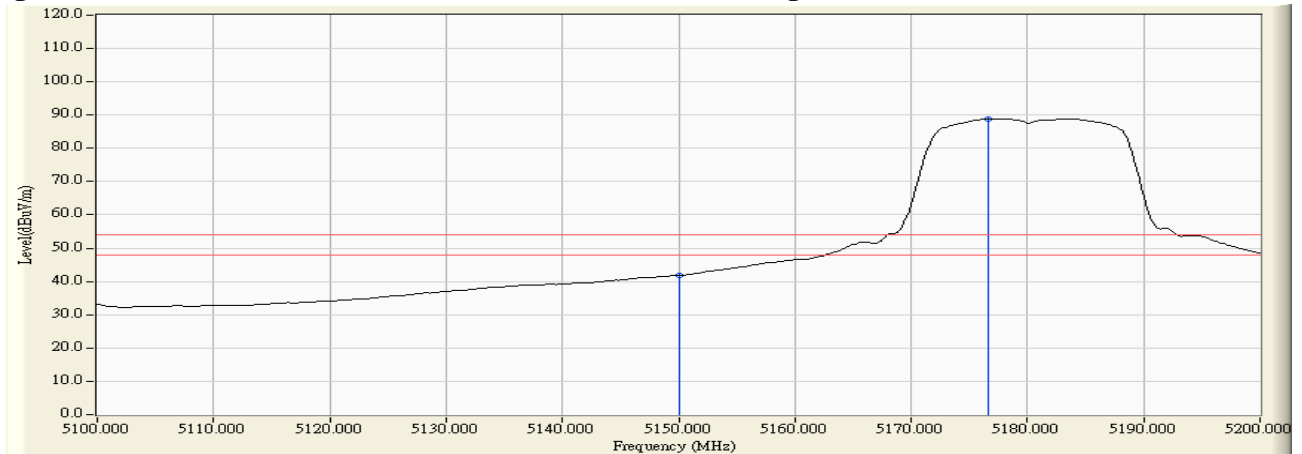

Figure Channel 36: Vertical (Average)



Note:

1. All readings above 1GHz are performed with peak and/or average measurements as necessary.
2. Peak measurements: RBW = 1MHz, VBW = 3 MHz, Sweep: Auto.
3. Average measurements: RBW = 1MHz, VBW = 10 Hz, Sweep: Auto.
4. “ * ”, means this data is the worst emission level.
5. Measurement Level = Reading Level + Correct Factor.
6. The average measurement was not performed when the peak measured data under the limit of average detection.

Product : Wireless Motherboard
 Test Item : Band Edge Data
 Test Site : No.3 OATS
 Test Mode : Mode 1: Transmit (802.11a-6Mbps) -Channel 64 (PIFA Antenna)

RF Radiated Measurement (Horizontal):

Channel No.	Frequency (MHz)	Correct Factor (dB)	Reading Level (dBuV)	Emission Level (dBuV/m)	Peak Limit (dBuV/m)	Average Limit (dBuV/m)	Result
64 (Peak)	5317.600	3.820	98.511	102.331	--	--	--
64 (Peak)	5350.000	3.716	57.236	60.953	74.00	54.00	Pass
64 (Average)	5316.400	3.823	84.944	88.768	--	--	--
64 (Average)	5350.000	3.716	37.275	40.992	74.00	54.00	Pass

Figure Channel 64: Horizontal (Peak)

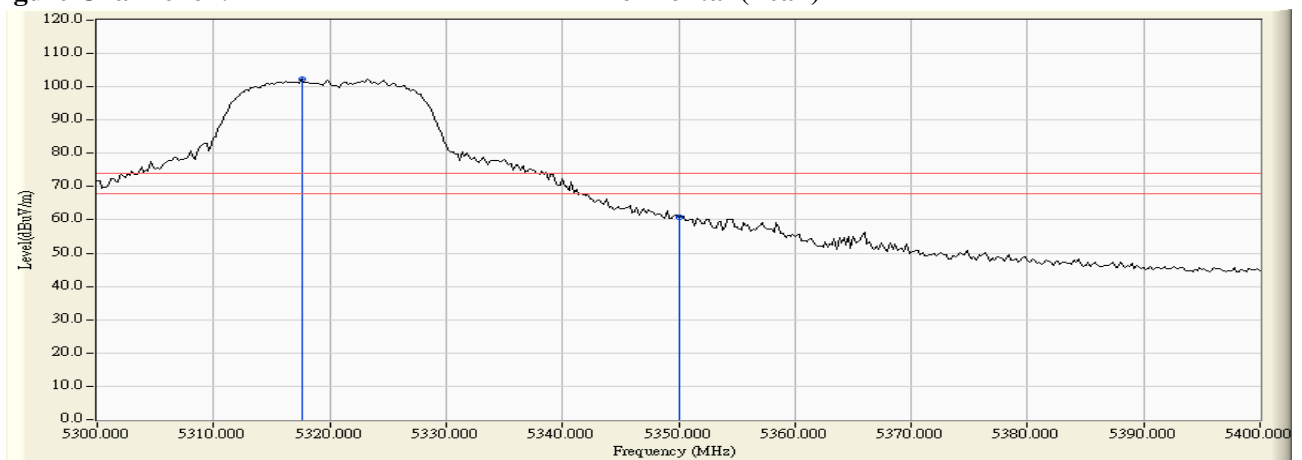
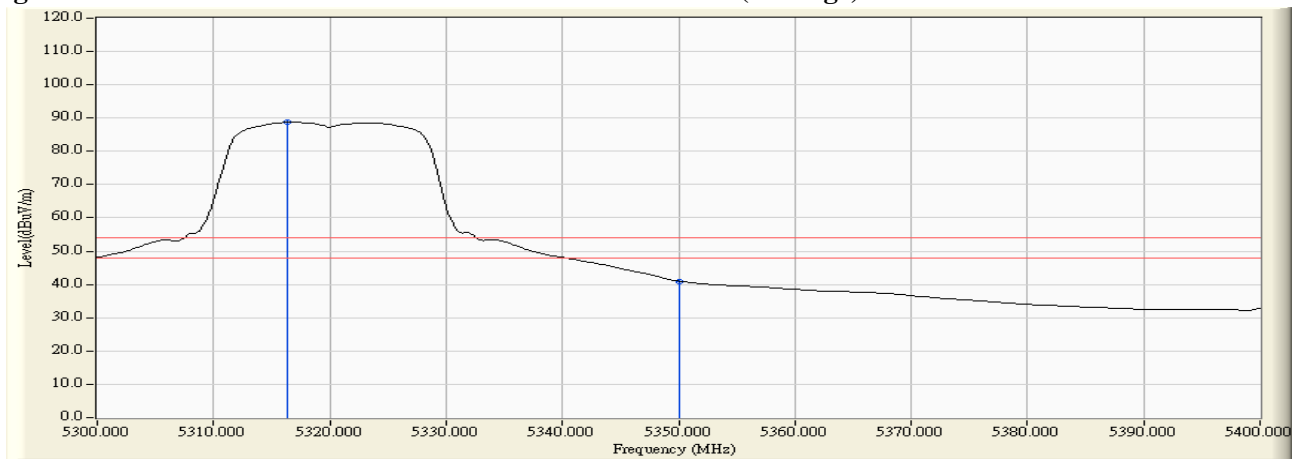

Figure Channel 64: Horizontal (Average)



Note:

1. All readings above 1GHz are performed with peak and/or average measurements as necessary.
2. Peak measurements: RBW = 1MHz, VBW = 3 MHz, Sweep: Auto.
3. Average measurements: RBW = 1MHz, VBW = 10 Hz, Sweep: Auto.
4. “ * ”, means this data is the worst emission level.
5. Measurement Level = Reading Level + Correct Factor.
6. The average measurement was not performed when the peak measured data under the limit of average detection.

Product : Wireless Motherboard
 Test Item : Band Edge Data
 Test Site : No.3 OATS
 Test Mode : Mode 1: Transmit (802.11a-6Mbps) -Channel 64 (PIFA Antenna)

RF Radiated Measurement (Vertical):

Channel No.	Frequency (MHz)	Correct Factor (dB)	Reading Level (dBuV)	Emission Level (dBuV/m)	Peak Limit (dBuV/m)	Average Limit (dBuV/m)	Result
64 (Peak)	5317.200	5.732	97.998	103.731	--	--	--
64 (Peak)	5350.000	5.691	54.037	59.729	74.00	54.00	Pass
64 (Peak)	5350.800	5.690	57.427	63.118	74.00	54.00	Pass
64 (Average)	5316.800	5.733	84.894	90.627	--	--	--
64 (Average)	5350.000	5.691	37.170	42.862	74.00	54.00	Pass

Figure Channel 64: Vertical (Peak)

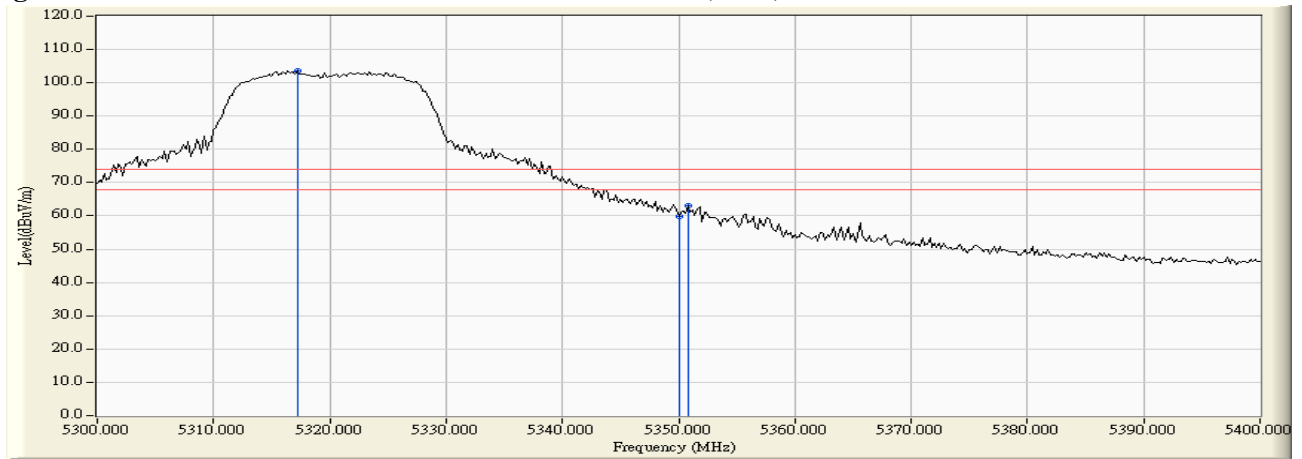
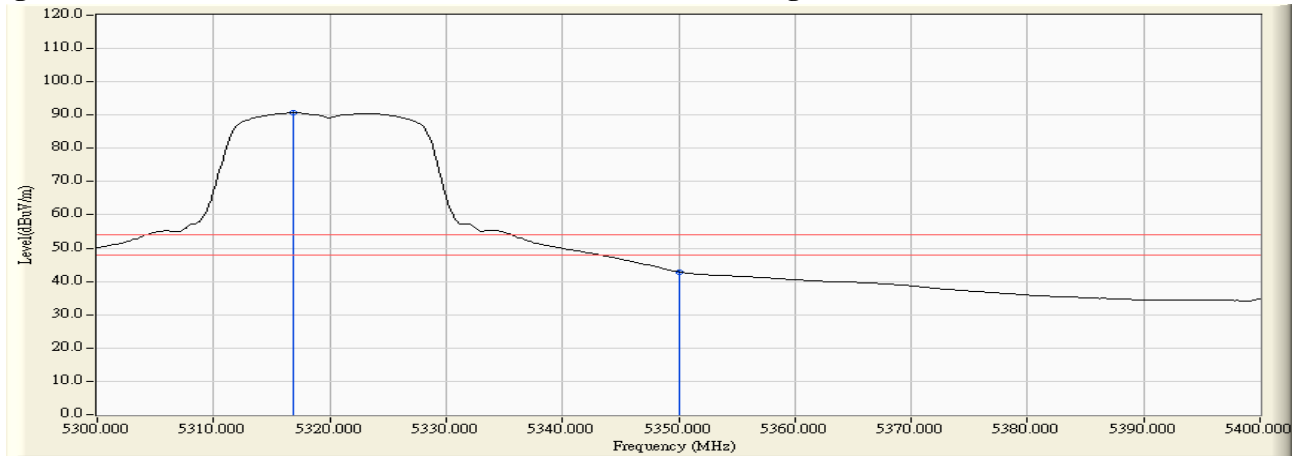

Figure Channel 64: Vertical (Average)



Note:

1. All readings above 1GHz are performed with peak and/or average measurements as necessary.
2. Peak measurements: RBW = 1MHz, VBW = 3 MHz, Sweep: Auto.
3. Average measurements: RBW = 1MHz, VBW = 10 Hz, Sweep: Auto.
4. “ * ”, means this data is the worst emission level.
5. Measurement Level = Reading Level + Correct Factor.
6. The average measurement was not performed when the peak measured data under the limit of average detection.

Product : Wireless Motherboard
 Test Item : Band Edge Data
 Test Site : No.3 OATS
 Test Mode : Mode 1: Transmit (802.11a-6Mbps) -Channel 100 (PIFA Antenna)

RF Radiated Measurement (Horizontal):

Channel No.	Frequency (MHz)	Correct Factor (dB)	Reading Level (dBuV)	Emission Level (dBuV/m)	Peak Limit (dBuV/m)	Average Limit (dBuV/m)	Result
100 (Peak)	5459.400	4.347	55.704	60.050	74.00	54.00	Pass
100 (Peak)	5460.000	4.354	52.612	56.966	74.00	54.00	Pass
100 (Peak)	5496.800	4.793	95.363	100.155	--	--	--
100 (Average)	5460.000	4.354	35.073	39.427	74.00	54.00	Pass
100 (Average)	5496.400	4.789	81.859	86.649	--	--	--

Figure Channel 100: Horizontal (Peak)

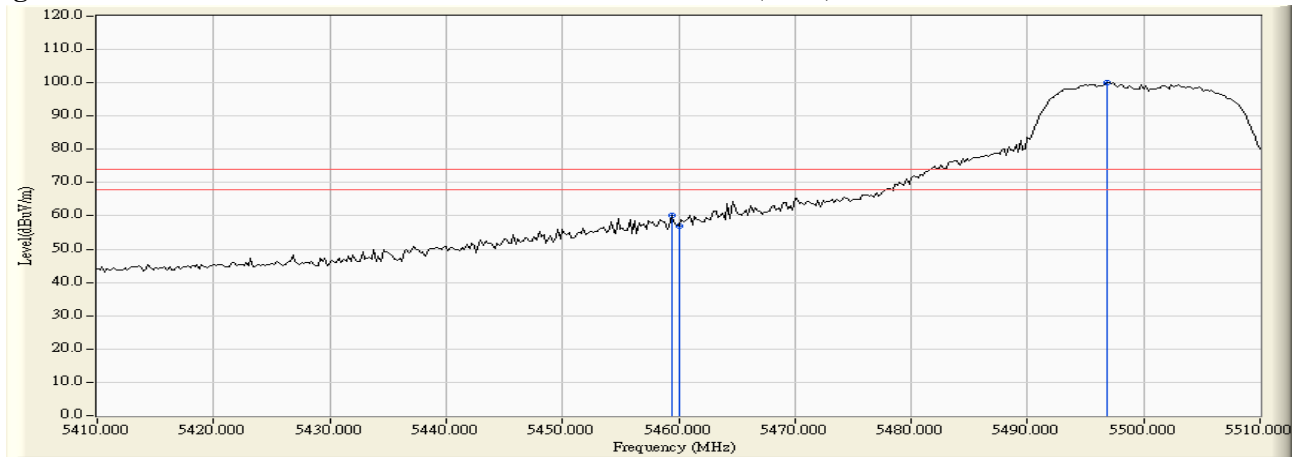
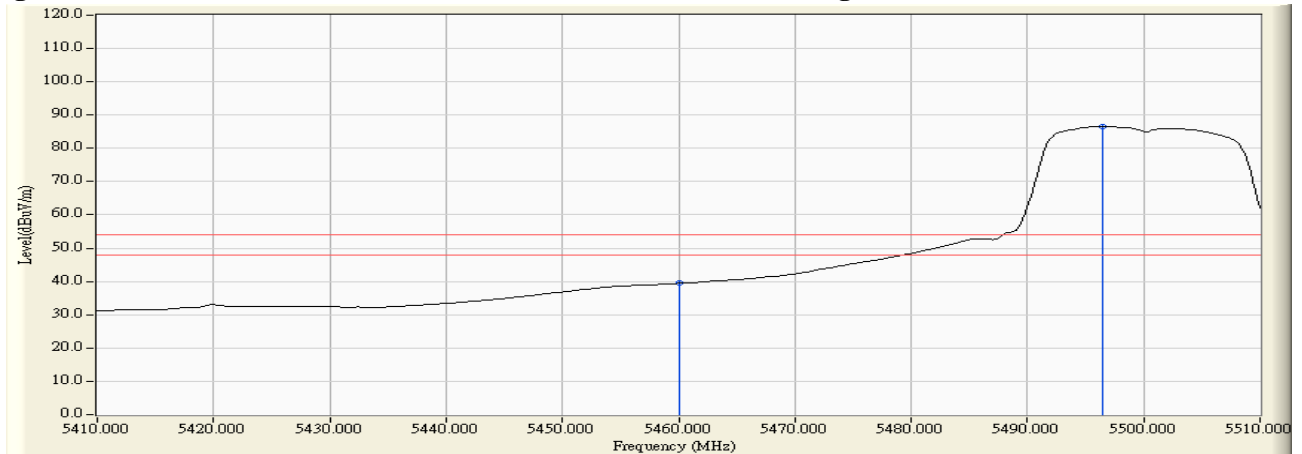

Figure Channel 100: Horizontal (Average)



Note:

1. All readings above 1GHz are performed with peak and/or average measurements as necessary.
2. Peak measurements: RBW = 1MHz, VBW = 3 MHz, Sweep: Auto.
3. Average measurements: RBW = 1MHz, VBW = 10 Hz, Sweep: Auto.
4. “ * ”, means this data is the worst emission level.
5. Measurement Level = Reading Level + Correct Factor.
6. The average measurement was not performed when the peak measured data under the limit of average detection.

Product : Wireless Motherboard
 Test Item : Band Edge Data
 Test Site : No.3 OATS
 Test Mode : Mode 1: Transmit (802.11a-6Mbps) -Channel 100 (PIFA Antenna)

RF Radiated Measurement (Vertical):

Channel No.	Frequency (MHz)	Correct Factor (dB)	Reading Level (dBuV)	Emission Level (dBuV/m)	Peak Limit (dBuV/m)	Average Limit (dBuV/m)	Result
100 (Peak)	5459.000	6.033	54.768	60.802	74.00	54.00	Pass
100 (Peak)	5460.000	6.041	52.175	58.216	74.00	54.00	Pass
100 (Peak)	5497.600	6.267	95.072	101.340	--	--	--
100 (Average)	5460.000	6.041	35.016	41.057	74.00	54.00	Pass
100 (Average)	5496.400	6.264	81.830	88.094	--	--	--

Figure Channel 100: Vertical (Peak)

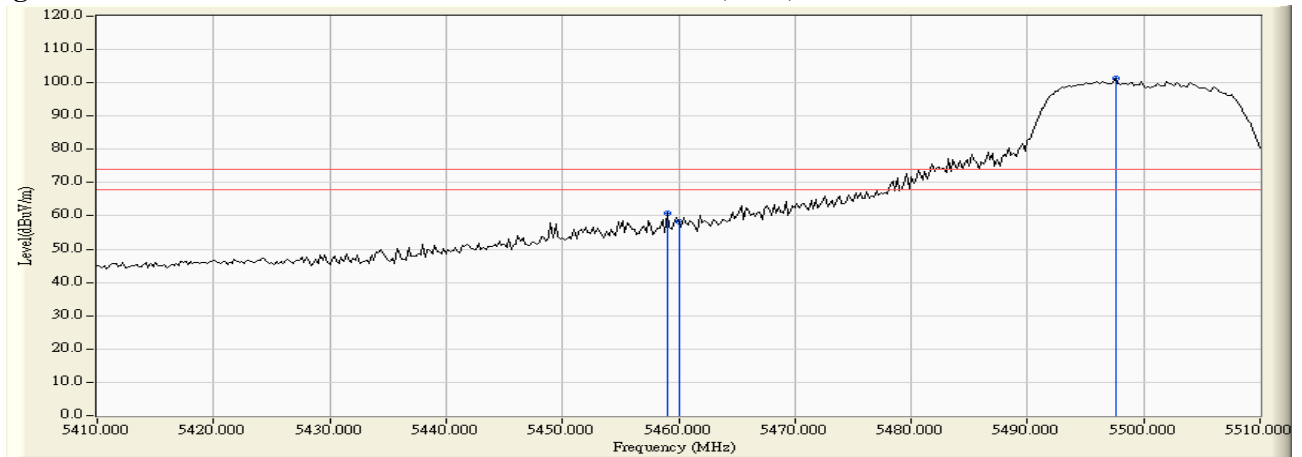
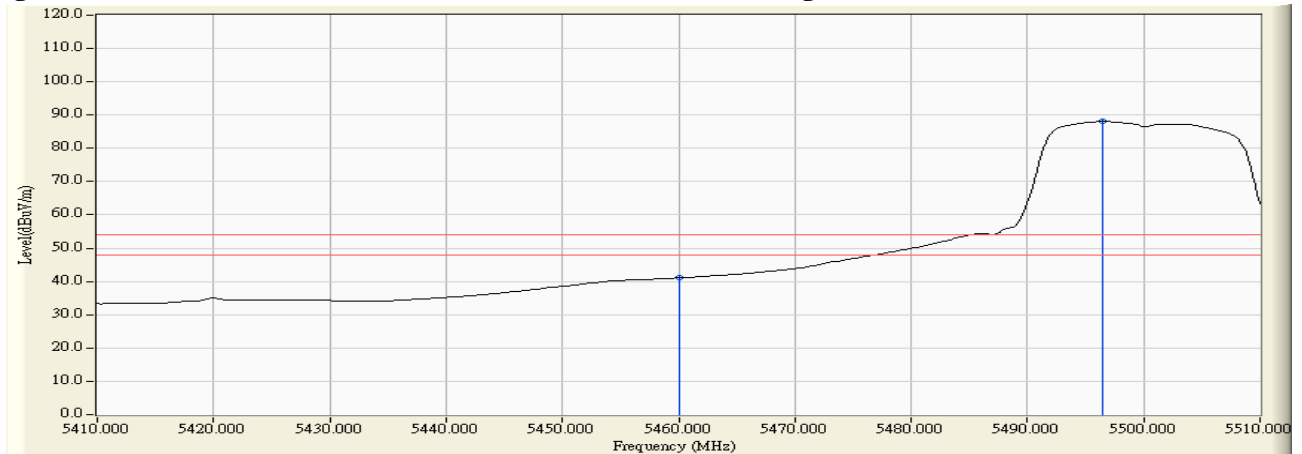

Figure Channel 100: Vertical (Average)



Note:

1. All readings above 1GHz are performed with peak and/or average measurements as necessary.
2. Peak measurements: RBW = 1MHz, VBW = 3 MHz, Sweep: Auto.
3. Average measurements: RBW = 1MHz, VBW = 10 Hz, Sweep: Auto.
4. “ * ”, means this data is the worst emission level.
5. Measurement Level = Reading Level + Correct Factor.
6. The average measurement was not performed when the peak measured data under the limit of average detection.

Product : Wireless Motherboard
 Test Item : Band Edge Data
 Test Site : No.3 OATS
 Test Mode : Mode 1: Transmit (802.11a-6Mbps) -Channel 100 (PIFA Antenna)

RF Radiated Measurement:

	Frequency (MHz)	Correct Factor (dB)	Reading Level (dBm)	Measure Level (dBm/m)	Margin (dB)	Limit (dBm/m)	Result
Horizontal	5470.000	18.334	-68.680	-50.346	-23.346	-27.000	Pass

	Frequency (MHz)	Correct Factor (dB)	Reading Level (dBm)	Measure Level (dBm/m)	Margin (dB)	Limit (dBm/m)	Result
Vertical	5470.000	19.335	-68.660	-49.325	-22.325	-27.000	Pass

Product : Wireless Motherboard
 Test Item : Band Edge Data
 Test Site : No.3 OATS
 Test Mode : Mode 1: Transmit (802.11a-6Mbps) -Channel 140 (PIFA Antenna)

RF Radiated Measurement:

	Frequency (MHz)	Correct Factor (dB)	Reading Level (dBm)	Measure Level (dBm/m)	Margin (dB)	Limit (dBm/m)	Result
Horizontal	5725.000	18.649	-67.220	-48.571	-21.571	-27.000	Pass

	Frequency (MHz)	Correct Factor (dB)	Reading Level (dBm)	Measure Level (dBm/m)	Margin (dB)	Limit (dBm/m)	Result
Vertical	5725.000	19.372	-69.180	-49.808	-22.808	-27.000	Pass

Product : Wireless Motherboard
 Test Item : Band Edge Data
 Test Site : No.3 OATS
 Test Mode : Mode 2: Transmit (802.11n-20BW 14.4Mbps) -Channel 36

RF Radiated Measurement (Horizontal):

Channel No.	Frequency (MHz)	Correct Factor (dB)	Reading Level (dBuV)	Emission Level (dBuV/m)	Peak Limit (dBuV/m)	Average Limit (dBuV/m)	Result
36 (Peak)	5145.800	3.355	66.168	69.523	74.00	54.00	Pass
36 (Peak)	5150.000	3.340	63.685	67.025	74.00	54.00	Pass
36 (Peak)	5184.200	3.220	105.730	108.949	--	--	--
36 (Average)	5150.000	3.340	46.897	50.237	74.00	54.00	Pass
36 (Average)	5176.600	3.246	92.708	95.954	--	--	--

Figure Channel 36: Horizontal (Peak)

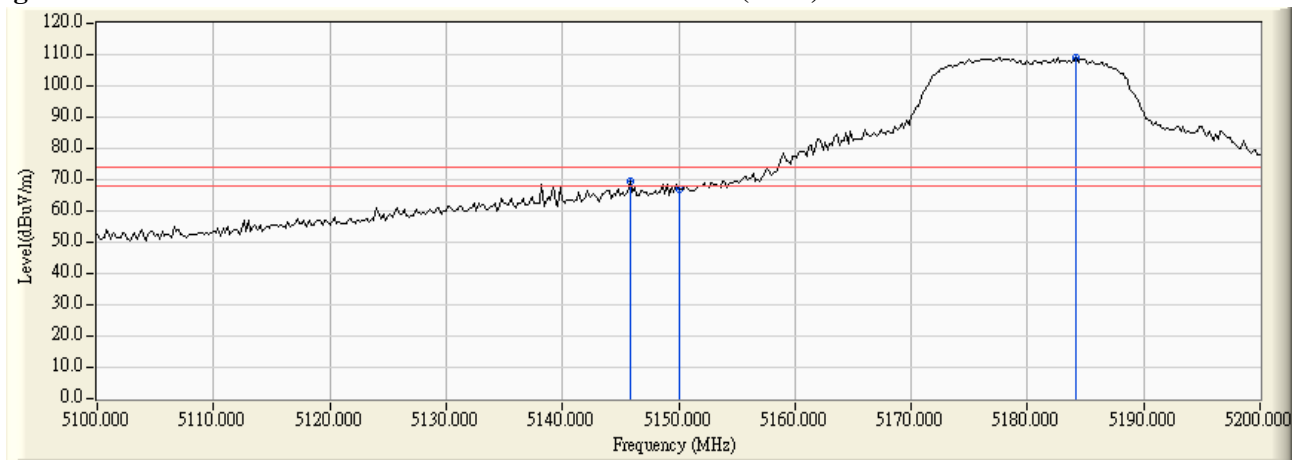
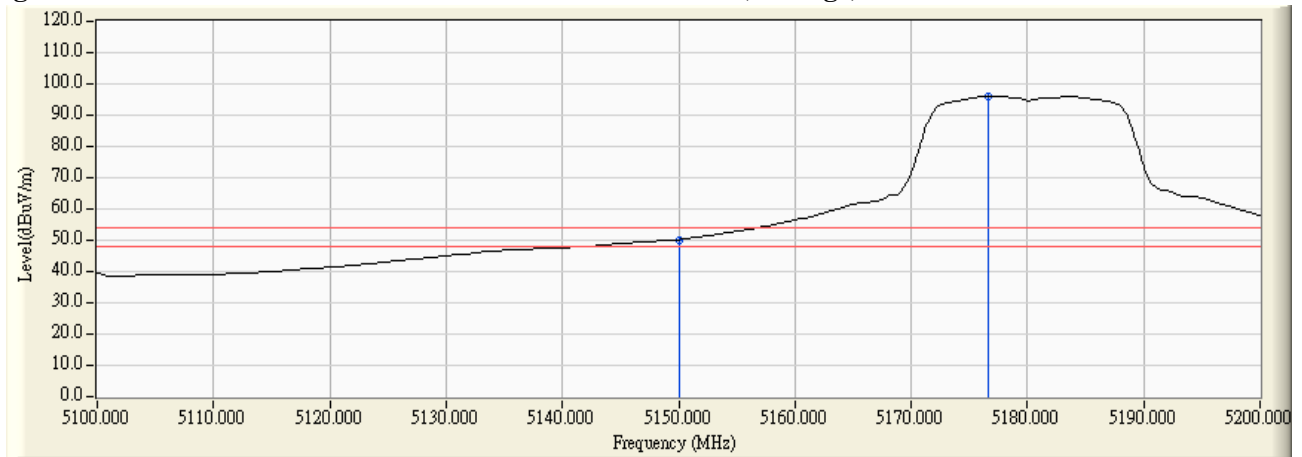

Figure Channel 36: Horizontal (Average)



Note:

1. All readings above 1GHz are performed with peak and/or average measurements as necessary.
2. Peak measurements: RBW = 1MHz, VBW = 3 MHz, Sweep: Auto.
3. Average measurements: RBW = 1MHz, VBW = 10 Hz, Sweep: Auto.
4. “ * ”, means this data is the worst emission level.
5. Measurement Level = Reading Level + Correct Factor.
6. The average measurement was not performed when the peak measured data under the limit of average detection.

Product : Wireless Motherboard
 Test Item : Band Edge Data
 Test Site : No.3 OATS
 Test Mode : Mode 2: Transmit (802.11n-20BW 14.4Mbps) -Channel 36

RF Radiated Measurement (Vertical):

Channel No.	Frequency (MHz)	Correct Factor (dB)	Reading Level (dBuV)	Emission Level (dBuV/m)	Peak Limit (dBuV/m)	Average Limit (dBuV/m)	Result
36 (Peak)	5144.000	5.243	65.799	71.042	74.00	54.00	Pass
36 (Peak)	5150.000	5.260	63.495	68.755	74.00	54.00	Pass
36 (Peak)	5177.600	5.336	103.571	108.906	--	--	--
36 (Average)	5150.000	5.260	45.139	50.399	74.00	54.00	Pass
36 (Average)	5176.600	5.333	90.141	95.474	--	--	--

Figure Channel 36: Vertical (Peak)

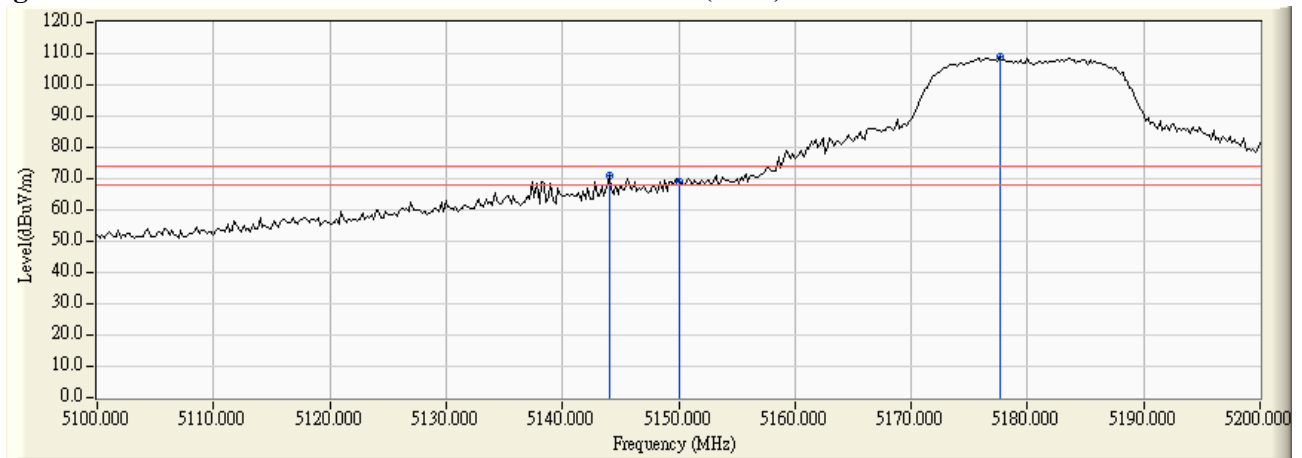
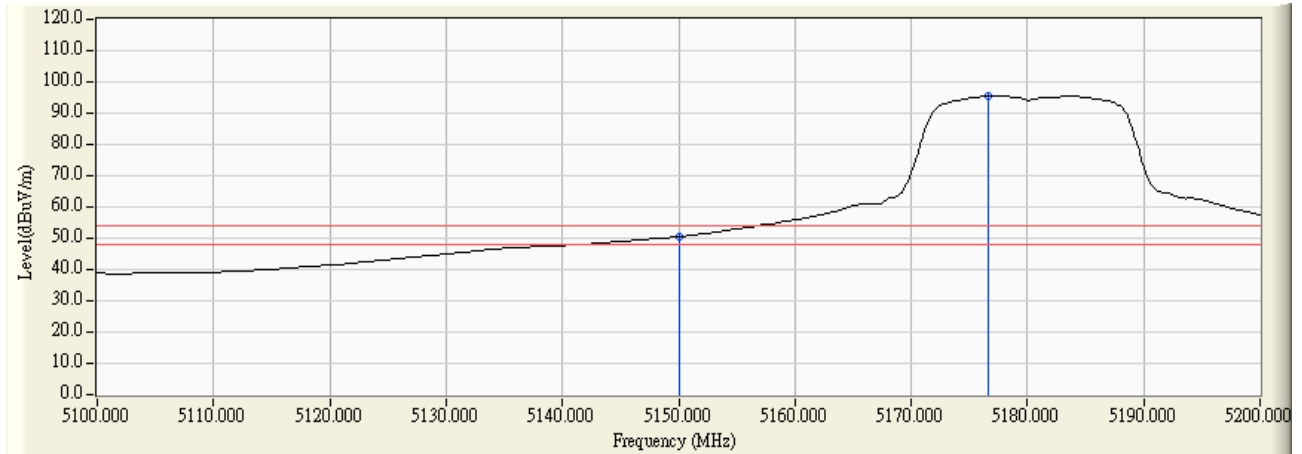

Figure Channel 36: Vertical (Average)



Note:

1. All readings above 1GHz are performed with peak and/or average measurements as necessary.
2. Peak measurements: RBW = 1MHz, VBW = 3 MHz, Sweep: Auto.
3. Average measurements: RBW = 1MHz, VBW = 10 Hz, Sweep: Auto.
4. “ * ”, means this data is the worst emission level.
5. Measurement Level = Reading Level + Correct Factor.
6. The average measurement was not performed when the peak measured data under the limit of average detection.

Product : Wireless Motherboard
 Test Item : Band Edge Data
 Test Site : No.3 OATS
 Test Mode : Mode 2: Transmit (802.11n-20BW 14.4Mbps) -Channel 64

RF Radiated Measurement (Horizontal):

Channel No.	Frequency (MHz)	Correct Factor (dB)	Reading Level (dBuV)	Emission Level (dBuV/m)	Peak Limit (dBuV/m)	Average Limit (dBuV/m)	Result
64 (Peak)	5317.200	3.821	106.175	109.996	--	--	--
64 (Peak)	5350.000	3.716	66.219	69.936	74.00	54.00	Pass
64 (Peak)	5350.400	3.714	68.762	72.477	74.00	54.00	Pass
64 (Average)	5316.400	3.823	89.547	93.371	--	--	--
64 (Average)	5350.000	3.716	45.864	49.581	74.00	54.00	Pass

Figure Channel 64: Horizontal (Peak)

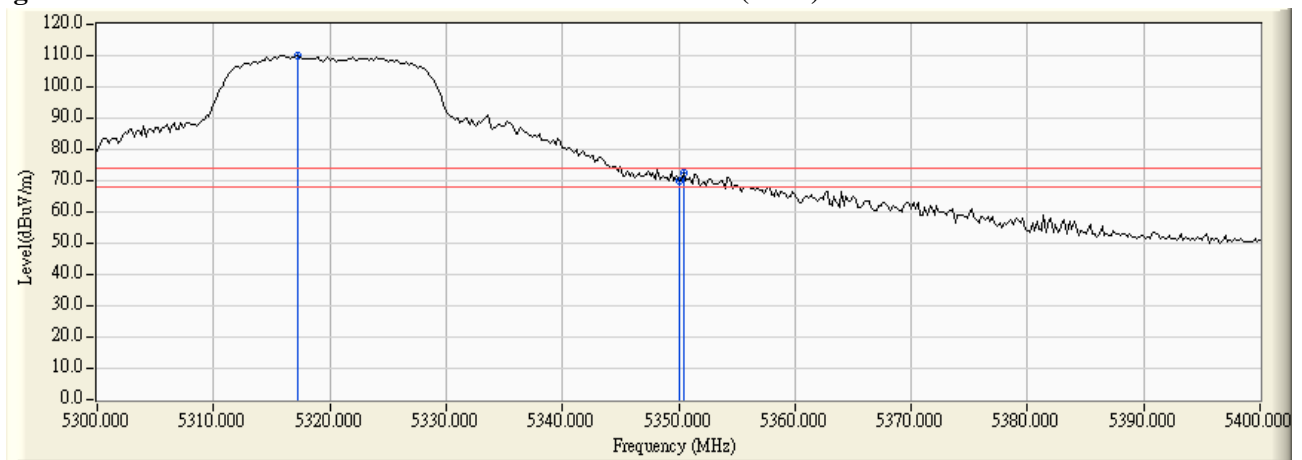
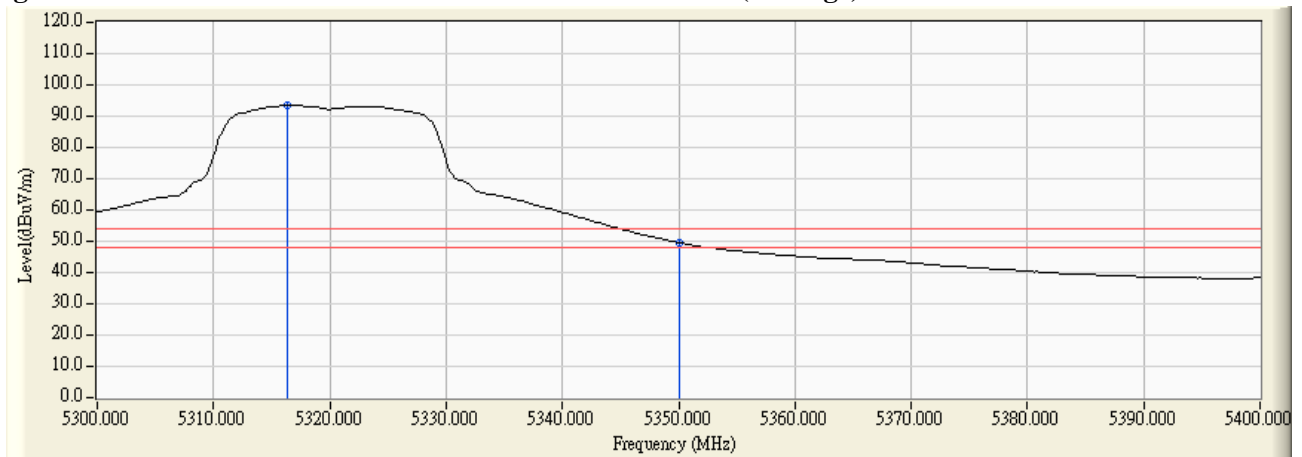

Figure Channel 64: Horizontal (Average)



Note:

1. All readings above 1GHz are performed with peak and/or average measurements as necessary.
2. Peak measurements: RBW = 1MHz, VBW = 3 MHz, Sweep: Auto.
3. Average measurements: RBW = 1MHz, VBW = 10 Hz, Sweep: Auto.
4. “ * ”, means this data is the worst emission level.
5. Measurement Level = Reading Level + Correct Factor.
6. The average measurement was not performed when the peak measured data under the limit of average detection.

Product : Wireless Motherboard
 Test Item : Band Edge Data
 Test Site : No.3 OATS
 Test Mode : Mode 2: Transmit (802.11n-20BW 14.4Mbps) -Channel 64

RF Radiated Measurement (Vertical):

Channel No.	Frequency (MHz)	Correct Factor (dB)	Reading Level (dBuV)	Emission Level (dBuV/m)	Peak Limit (dBuV/m)	Average Limit (dBuV/m)	Result
64 (Peak)	5315.600	5.735	103.543	109.278	--	--	--
64 (Peak)	5350.000	5.691	64.106	69.798	74.00	54.00	Pass
64 (Peak)	5351.600	5.689	65.741	71.431	74.00	54.00	Pass
64 (Average)	5316.200	5.733	87.023	92.757	--	--	--
64 (Average)	5350.000	5.691	44.726	50.418	74.00	54.00	Pass

Figure Channel 64: Vertical (Peak)

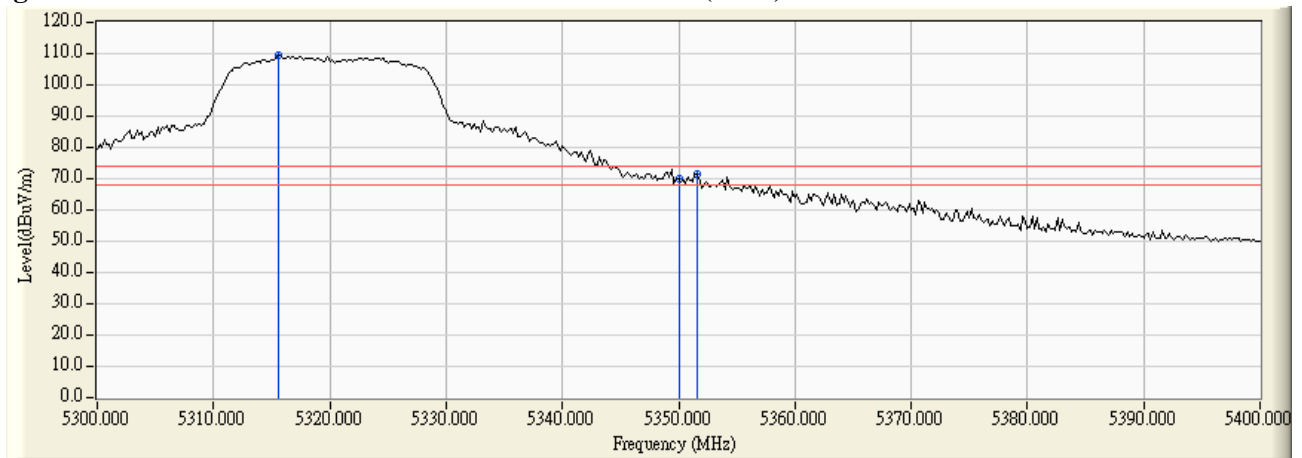
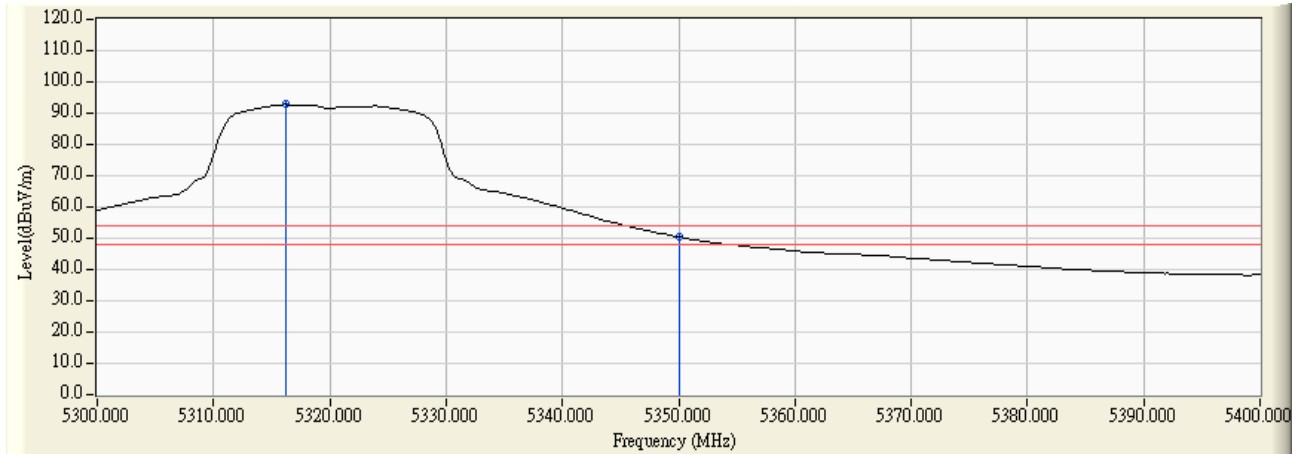

Figure Channel 64: Vertical (Average)



Note:

1. All readings above 1GHz are performed with peak and/or average measurements as necessary.
2. Peak measurements: RBW = 1MHz, VBW = 3 MHz, Sweep: Auto.
3. Average measurements: RBW = 1MHz, VBW = 10 Hz, Sweep: Auto.
4. “ * ”, means this data is the worst emission level.
5. Measurement Level = Reading Level + Correct Factor.
6. The average measurement was not performed when the peak measured data under the limit of average detection.

Product : Wireless Motherboard
 Test Item : Band Edge Data
 Test Site : No.3 OATS
 Test Mode : Mode 2: Transmit (802.11n-20BW 14.4Mbps) -Channel 100

RF Radiated Measurement (Horizontal):

Channel No.	Frequency (MHz)	Correct Factor (dB)	Reading Level (dBuV)	Emission Level (dBuV/m)	Peak Limit (dBuV/m)	Average Limit (dBuV/m)	Result
100 (Peak)	5459.000	4.340	65.553	69.893	74.00	54.00	Pass
100 (Peak)	5460.000	4.354	64.486	68.840	74.00	54.00	Pass
100 (Peak)	5497.400	4.797	103.981	108.777	--	--	--
100 (Average)	5460.000	4.354	42.755	47.109	74.00	54.00	Pass

Figure Channel 100: Horizontal (Peak)

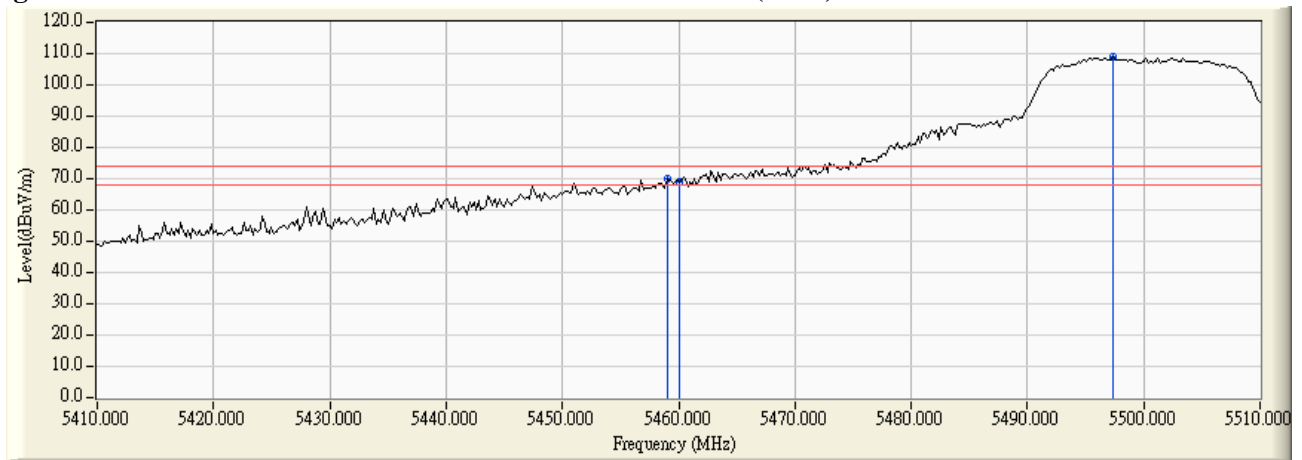
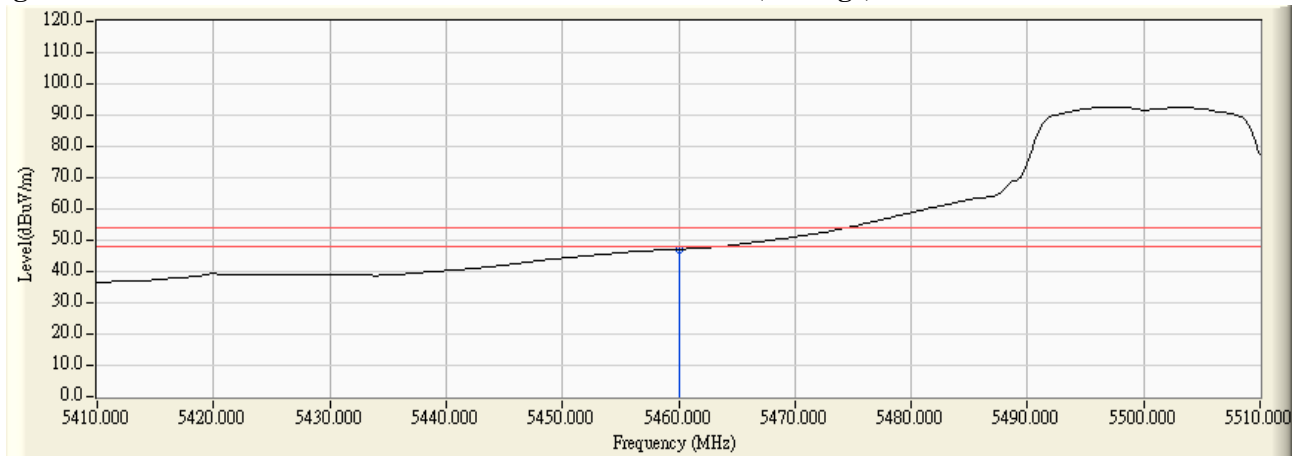

Figure Channel 100: Horizontal (Average)



Note:

1. All readings above 1GHz are performed with peak and/or average measurements as necessary.
2. Peak measurements: RBW = 1MHz, VBW = 3 MHz, Sweep: Auto.
3. Average measurements: RBW = 1MHz, VBW = 10 Hz, Sweep: Auto.
4. “ * ”, means this data is the worst emission level.
5. Measurement Level = Reading Level + Correct Factor.
6. The average measurement was not performed when the peak measured data under the limit of average detection.

Product : Wireless Motherboard
 Test Item : Band Edge Data
 Test Site : No.3 OATS
 Test Mode : Mode 2: Transmit (802.11n-20BW 14.4Mbps) -Channel 100

RF Radiated Measurement (Vertical):

Channel No.	Frequency (MHz)	Correct Factor (dB)	Reading Level (dBuV)	Emission Level (dBuV/m)	Peak Limit (dBuV/m)	Average Limit (dBuV/m)	Result
100 (Peak)	5459.600	6.039	64.129	70.167	74.00	54.00	Pass
100 (Peak)	5460.000	6.041	63.243	69.284	74.00	54.00	Pass
100 (Peak)	5496.000	6.263	103.102	109.365	--	--	--
100 (Average)	5460.000	6.041	42.379	48.420	74.00	54.00	Pass
100 (Average)	5497.000	6.266	87.041	93.307	--	--	--

Figure Channel 100: Vertical (Peak)

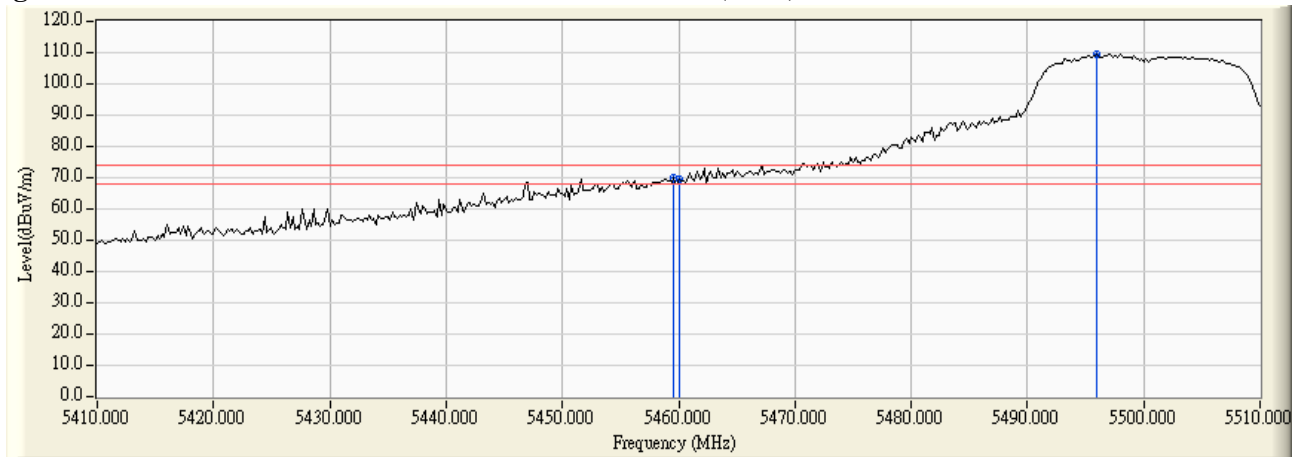
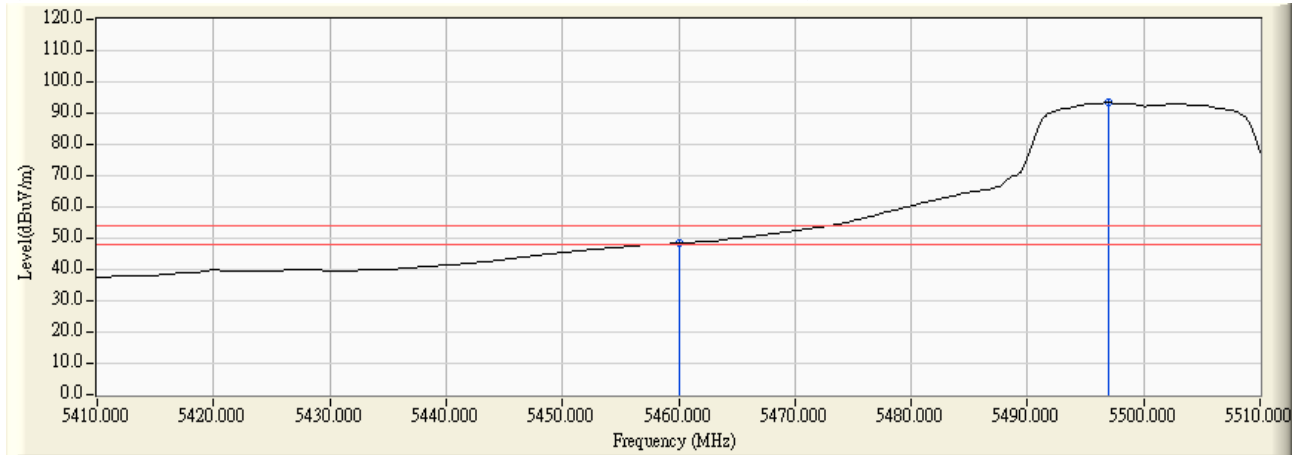

Figure Channel 100: Vertical (Average)



Note:

1. All readings above 1GHz are performed with peak and/or average measurements as necessary.
2. Peak measurements: RBW = 1MHz, VBW = 3 MHz, Sweep: Auto.
3. Average measurements: RBW = 1MHz, VBW = 10 Hz, Sweep: Auto.
4. “ * ”, means this data is the worst emission level.
5. Measurement Level = Reading Level + Correct Factor.
6. The average measurement was not performed when the peak measured data under the limit of average detection.

Product : Wireless Motherboard
 Test Item : Band Edge Data
 Test Site : No.3 OATS
 Test Mode : Mode 2: Transmit (802.11n-20BW 14.4Mbps) -Channel 100

RF Radiated Measurement:

	Frequency (MHz)	Correct Factor (dB)	Reading Level (dBm)	Measure Level (dBm/m)	Margin (dB)	Limit (dBm/m)	Result
Horizontal	5470.000	14.189	-78.790	-64.601	-37.601	-27.000	Pass

	Frequency (MHz)	Correct Factor (dB)	Reading Level (dBm)	Measure Level (dBm/m)	Margin (dB)	Limit (dBm/m)	Result
Vertical	5470.000	13.630	-76.570	-62.940	-35.940	-27.000	Pass

Product : Wireless Motherboard
 Test Item : Band Edge Data
 Test Site : No.3 OATS
 Test Mode : Mode 2: Transmit (802.11n-20BW 14.4Mbps) -Channel 140

RF Radiated Measurement:

	Frequency (MHz)	Correct Factor (dB)	Reading Level (dBm)	Measure Level (dBm/m)	Margin (dB)	Limit (dBm/m)	Result
Horizontal	5725.000	14.557	-78.200	-63.643	-36.643	-27.000	Pass

	Frequency (MHz)	Correct Factor (dB)	Reading Level (dBm)	Measure Level (dBm/m)	Margin (dB)	Limit (dBm/m)	Result
Vertical	5725.000	14.292	-77.520	-63.228	-36.228	-27.000	Pass

Product : Wireless Motherboard
 Test Item : Band Edge Data
 Test Site : No.3 OATS
 Test Mode : Mode 3: Transmit (802.11n-40BW 30Mbps) -Channel 38

RF Radiated Measurement (Horizontal):

Channel No.	Frequency (MHz)	Correct Factor (dB)	Reading Level (dBuV)	Emission Level (dBuV/m)	Peak Limit (dBuV/m)	Average Limit (dBuV/m)	Result
38 (Peak)	5150.000	3.340	67.193	70.533	74.00	54.00	Pass
38 (Peak)	5194.600	3.176	99.051	102.227	--	--	--
38 (Average)	5150.000	3.340	43.009	46.349	74.00	54.00	Pass
38 (Average)	5195.000	3.173	78.109	81.283	--	--	--

Figure Channel 38: Horizontal (Peak)

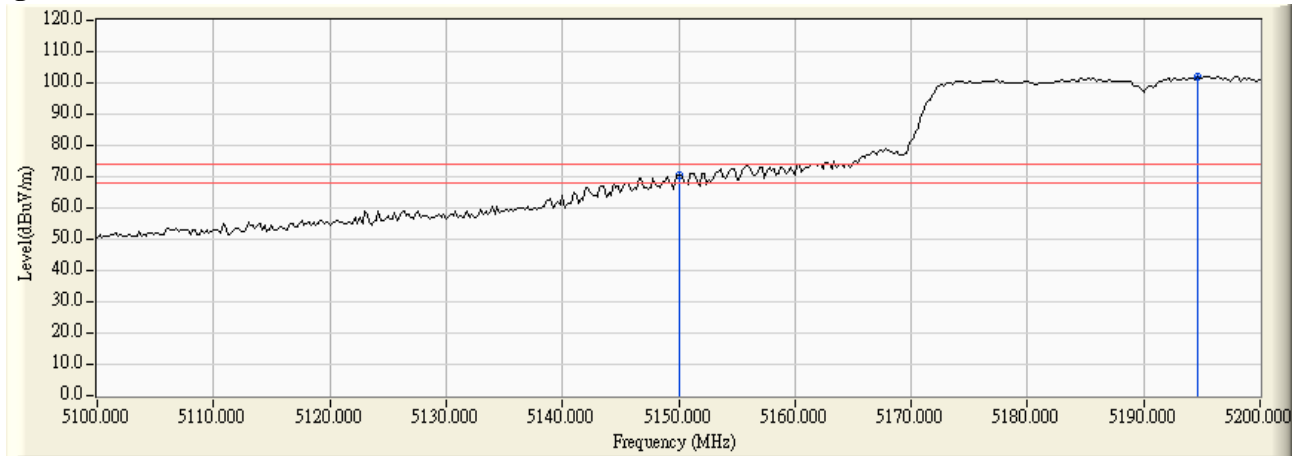
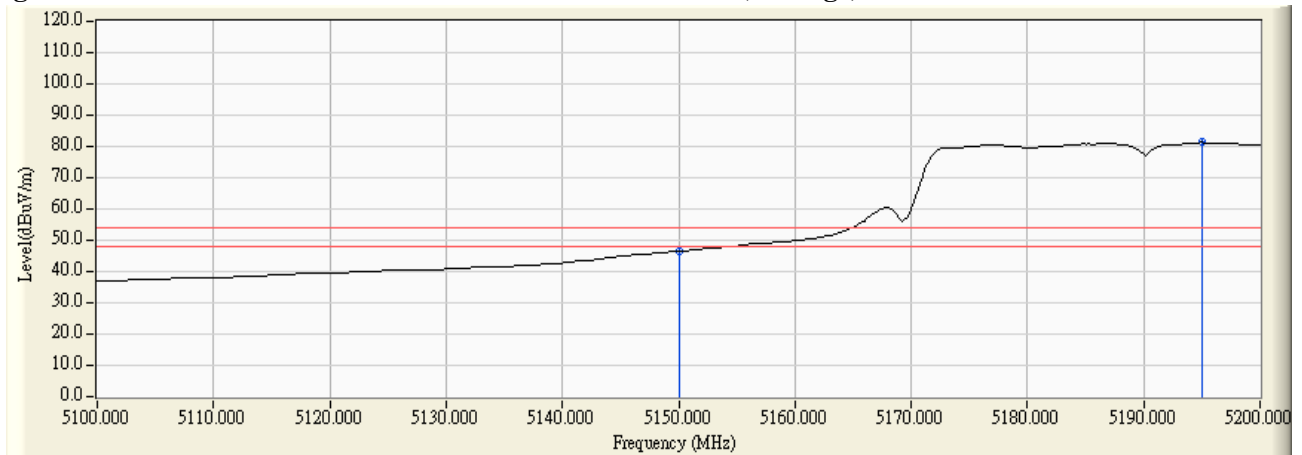

Figure Channel 38: Horizontal (Average)



Note:

1. All readings above 1GHz are performed with peak and/or average measurements as necessary.
2. Peak measurements: RBW = 1MHz, VBW = 3 MHz, Sweep: Auto.
3. Average measurements: RBW = 1MHz, VBW = 10 Hz, Sweep: Auto.
4. “ * ”, means this data is the worst emission level.
5. Measurement Level = Reading Level + Correct Factor.
6. The average measurement was not performed when the peak measured data under the limit of average detection.

Product : Wireless Motherboard
 Test Item : Band Edge Data
 Test Site : No.3 OATS
 Test Mode : Mode 3: Transmit (802.11n-40BW 30Mbps) -Channel 38

RF Radiated Measurement (Vertical):

Channel No.	Frequency (MHz)	Correct Factor (dB)	Reading Level (dBuV)	Emission Level (dBuV/m)	Peak Limit (dBuV/m)	Average Limit (dBuV/m)	Result
38 (Peak)	5148.600	5.256	62.952	68.208	74.00	54.00	Pass
38 (Peak)	5150.000	5.260	60.045	65.305	74.00	54.00	Pass
38 (Peak)	5198.200	5.382	98.135	103.516	--	--	--
38 (Average)	5150.000	5.260	43.078	48.338	74.00	54.00	Pass
38 (Average)	5195.200	5.375	77.438	82.814	--	--	--

Figure Channel 38: Vertical (Peak)

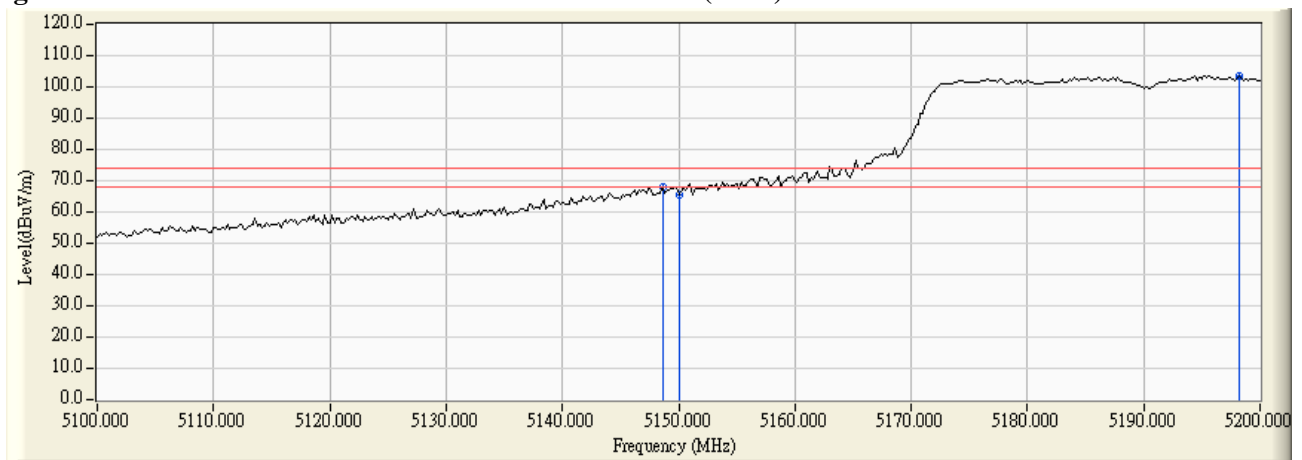
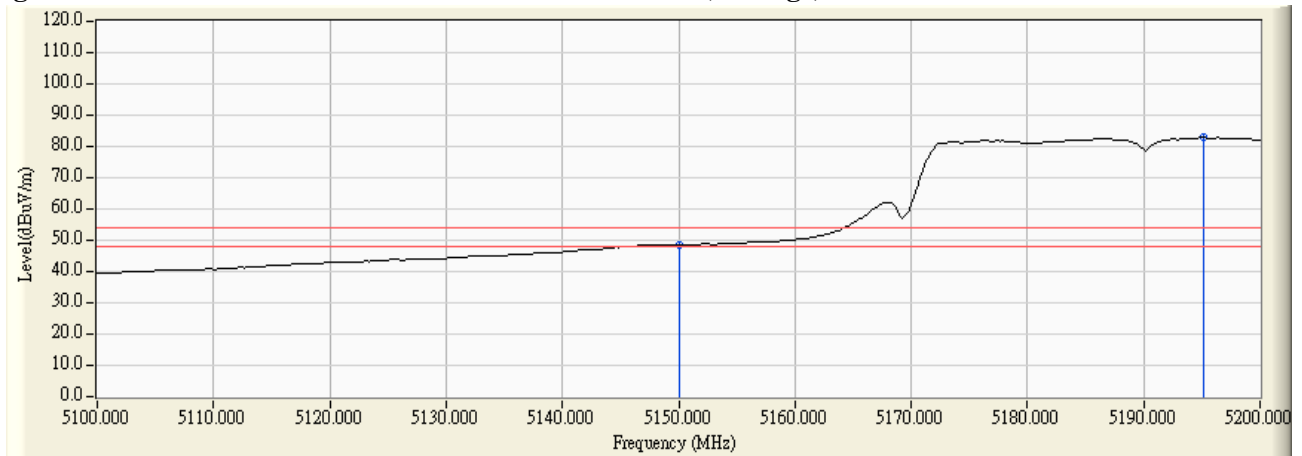

Figure Channel 38: Vertical (Average)



Note:

1. All readings above 1GHz are performed with peak and/or average measurements as necessary.
2. Peak measurements: RBW = 1MHz, VBW = 3 MHz, Sweep: Auto.
3. Average measurements: RBW = 1MHz, VBW = 10 Hz, Sweep: Auto.
4. “ * ”, means this data is the worst emission level.
5. Measurement Level = Reading Level + Correct Factor.
6. The average measurement was not performed when the peak measured data under the limit of average detection.

Product : Wireless Motherboard
 Test Item : Band Edge Data
 Test Site : No.3 OATS
 Test Mode : Mode 3: Transmit (802.11n-40BW 30Mbps) -Channel 62

RF Radiated Measurement (Horizontal):

Channel No.	Frequency (MHz)	Correct Factor (dB)	Reading Level (dBuV)	Emission Level (dBuV/m)	Peak Limit (dBuV/m)	Average Limit (dBuV/m)	Result
62 (Peak)	5314.400	3.831	98.360	102.190	--	--	--
62 (Peak)	5350.000	3.716	64.512	68.229	74.00	54.00	Pass
62 (Average)	5305.000	3.860	77.414	81.275	--	--	--
62 (Average)	5350.000	3.716	44.419	48.136	74.00	54.00	Pass

Figure Channel 62: Horizontal (Peak)

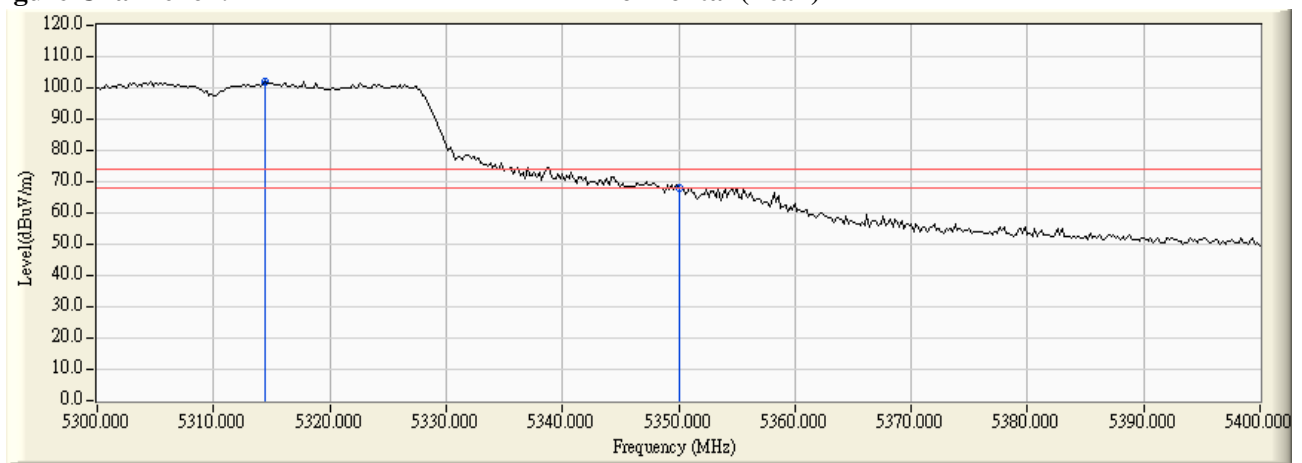
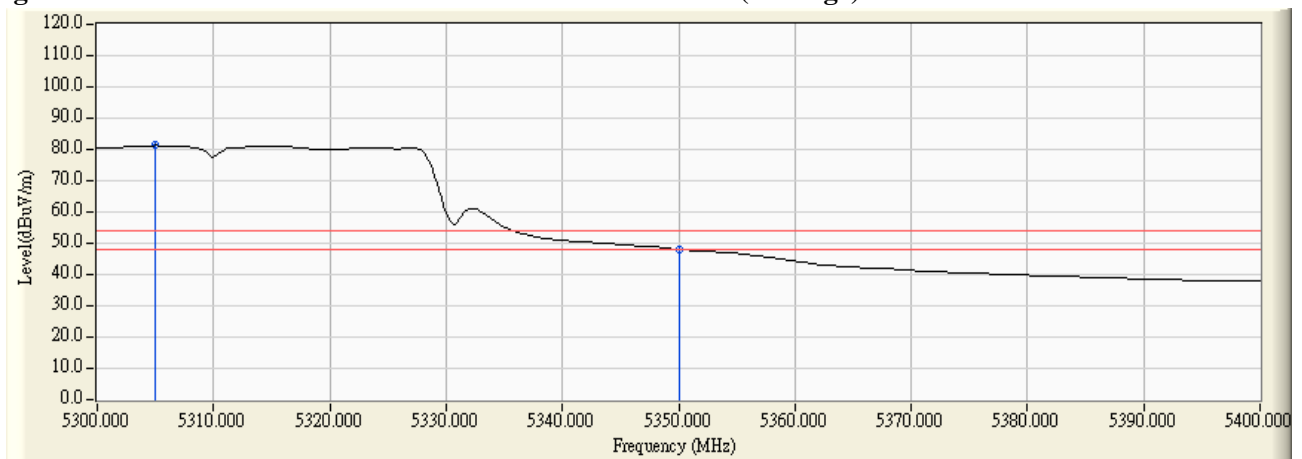

Figure Channel 62: Horizontal (Average)



Note:

1. All readings above 1GHz are performed with peak and/or average measurements as necessary.
2. Peak measurements: RBW = 1MHz, VBW = 3 MHz, Sweep: Auto.
3. Average measurements: RBW = 1MHz, VBW = 10 Hz, Sweep: Auto.
4. “ * ”, means this data is the worst emission level.
5. Measurement Level = Reading Level + Correct Factor.
6. The average measurement was not performed when the peak measured data under the limit of average detection.

Product : Wireless Motherboard
 Test Item : Band Edge Data
 Test Site : No.3 OATS
 Test Mode : Mode 3: Transmit (802.11n-40BW 30Mbps) -Channel 62

RF Radiated Measurement (Vertical):

Channel No.	Frequency (MHz)	Correct Factor (dB)	Reading Level (dBuV)	Emission Level (dBuV/m)	Peak Limit (dBuV/m)	Average Limit (dBuV/m)	Result
62 (Peak)	5314.200	5.737	97.127	102.864	--	--	--
62 (Peak)	5350.000	5.691	61.219	66.911	74.00	54.00	Pass
62 (Peak)	5352.400	5.689	62.753	68.441	74.00	54.00	Pass
62 (Average)	5315.000	5.736	76.484	82.220	--	--	--
62 (Average)	5350.000	5.691	43.197	48.889	74.00	54.00	Pass

Figure Channel 62: Vertical (Peak)

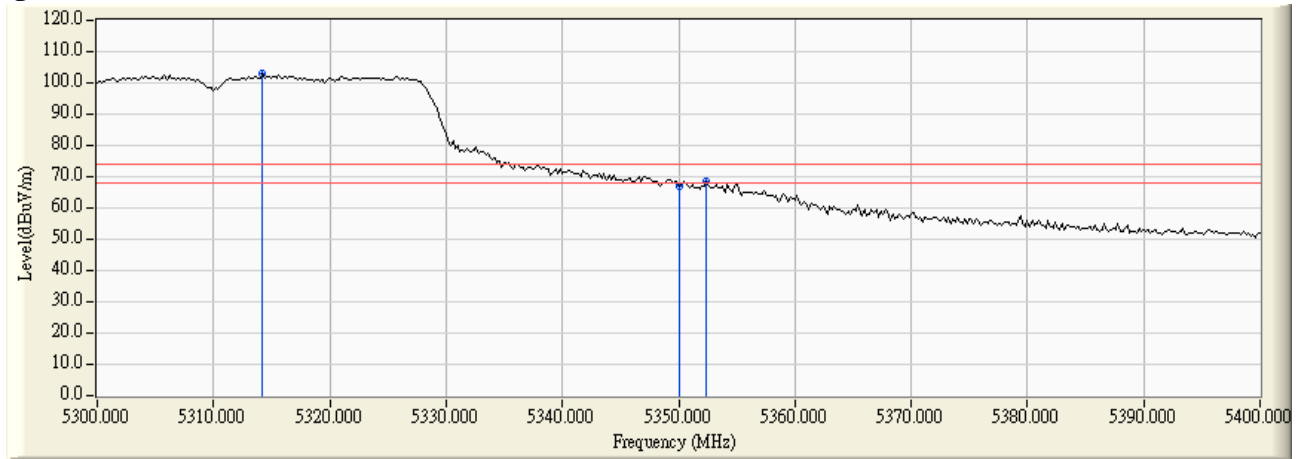
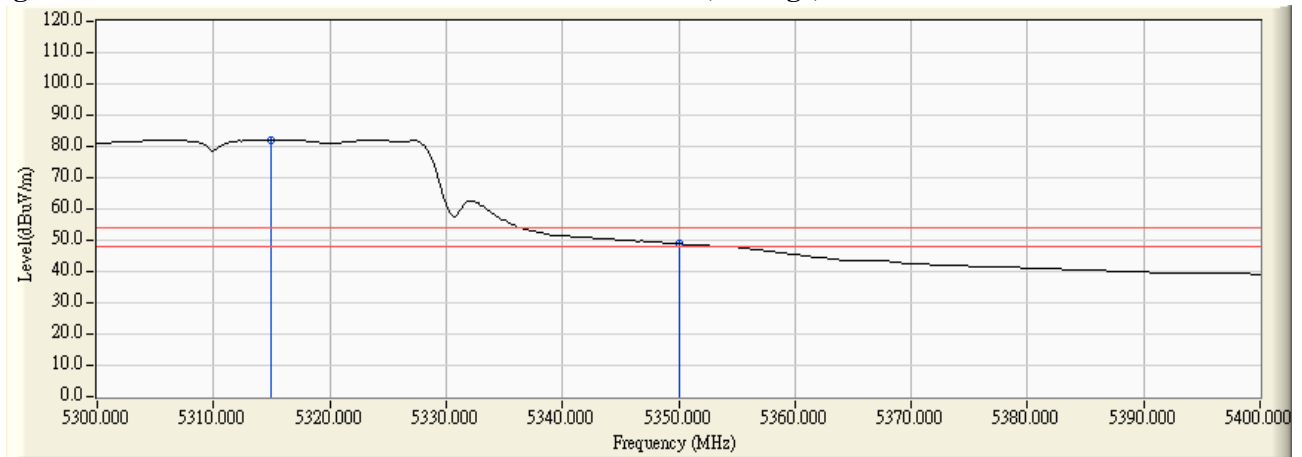

Figure Channel 62: Vertical (Average)



Note:

1. All readings above 1GHz are performed with peak and/or average measurements as necessary.
2. Peak measurements: RBW = 1MHz, VBW = 3 MHz, Sweep: Auto.
3. Average measurements: RBW = 1MHz, VBW = 10 Hz, Sweep: Auto.
4. “ * ”, means this data is the worst emission level.
5. Measurement Level = Reading Level + Correct Factor.
6. The average measurement was not performed when the peak measured data under the limit of average detection.

Product : Wireless Motherboard
 Test Item : Band Edge Data
 Test Site : No.3 OATS
 Test Mode : Mode 3: Transmit (802.11n-40BW 30Mbps) -Channel 102

RF Radiated Measurement (Horizontal):

Channel No.	Frequency (MHz)	Correct Factor (dB)	Reading Level (dBuV)	Emission Level (dBuV/m)	Peak Limit (dBuV/m)	Average Limit (dBuV/m)	Result
102 (Peak)	5459.000	4.340	64.937	69.277	74.00	54.00	Pass
102 (Peak)	5460.000	4.354	64.192	68.546	74.00	54.00	Pass
102 (Peak)	5504.000	4.843	96.286	101.128	--	--	--
102 (Average)	5460.000	4.354	43.107	47.461	74.00	54.00	Pass
102 (Average)	5494.400	4.776	75.821	80.597	--	--	--

Figure Channel 102: Horizontal (Peak)

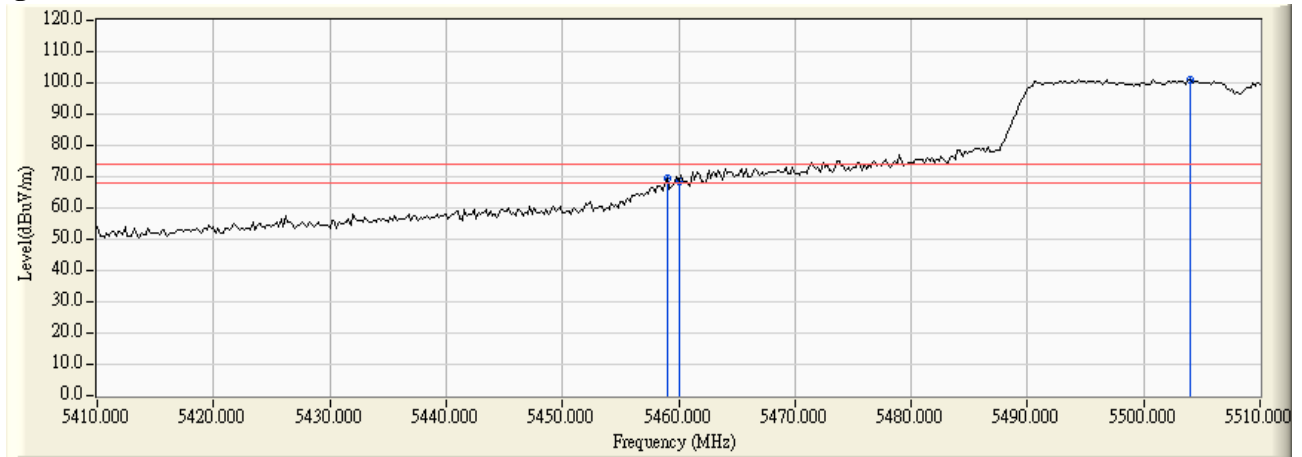
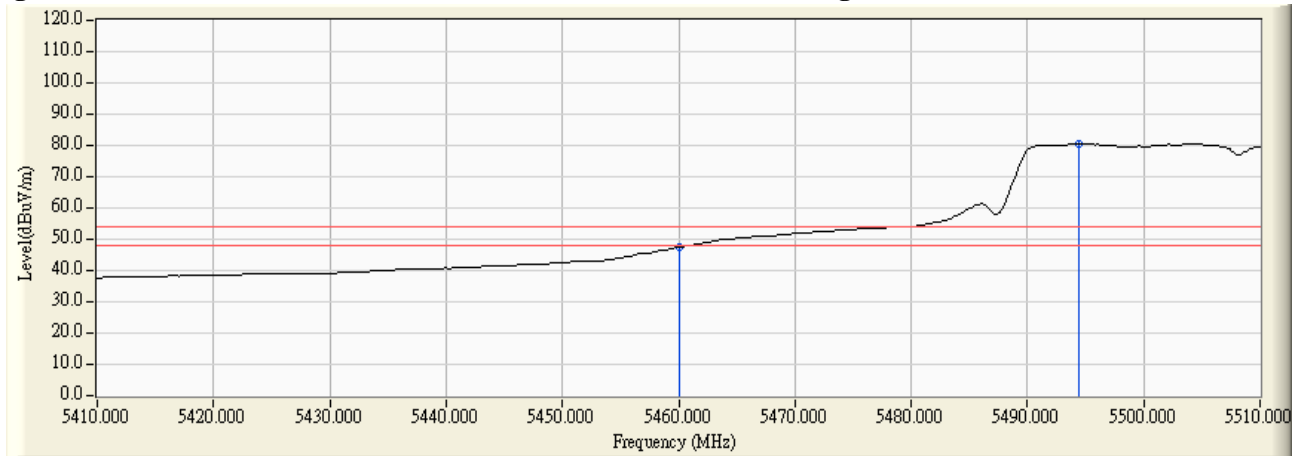

Figure Channel 102: Horizontal (Average)



Note:

1. All readings above 1GHz are performed with peak and/or average measurements as necessary.
2. Peak measurements: RBW = 1MHz, VBW = 3 MHz, Sweep: Auto.
3. Average measurements: RBW = 1MHz, VBW = 10 Hz, Sweep: Auto.
4. “ * ”, means this data is the worst emission level.
5. Measurement Level = Reading Level + Correct Factor.
6. The average measurement was not performed when the peak measured data under the limit of average detection.

Product : Wireless Motherboard
 Test Item : Band Edge Data
 Test Site : No.3 OATS
 Test Mode : Mode 3: Transmit (802.11n-40BW 30Mbps) -Channel 102

RF Radiated Measurement (Vertical):

Channel No.	Frequency (MHz)	Correct Factor (dB)	Reading Level (dBuV)	Emission Level (dBuV/m)	Peak Limit (dBuV/m)	Average Limit (dBuV/m)	Result
102 (Peak)	5458.400	6.029	64.788	70.818	74.00	54.00	Pass
102 (Peak)	5460.000	6.041	63.703	69.744	74.00	54.00	Pass
102 (Peak)	5502.000	6.281	96.836	103.117	--	--	--
102 (Average)	5460.000	6.041	42.501	48.542	74.00	54.00	Pass
102 (Average)	5505.000	6.290	75.799	82.089	--	--	--

Figure Channel 102: Vertical (Peak)

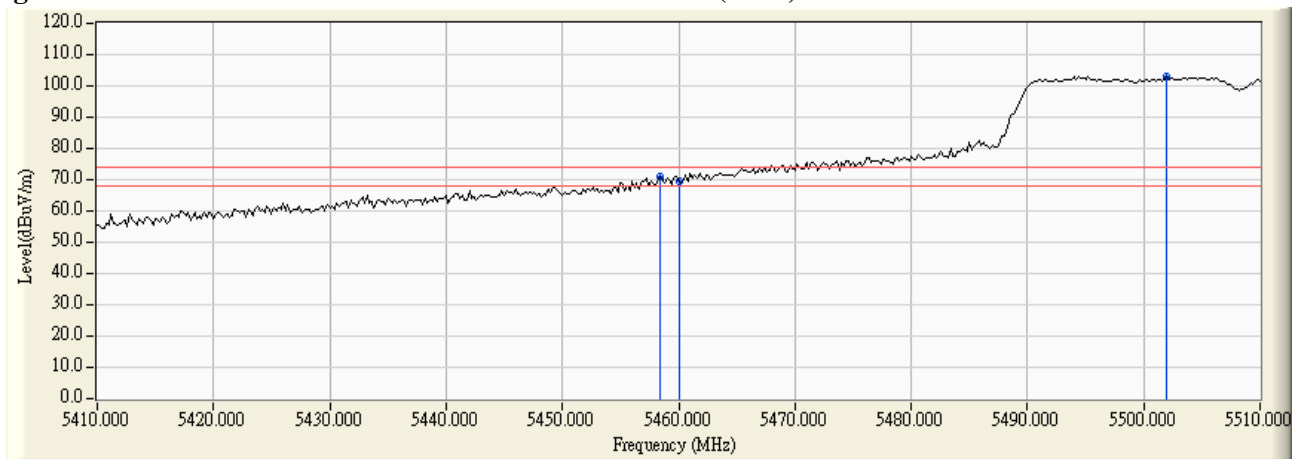

Figure Channel 102: Vertical (Average)



Note:

1. All readings above 1GHz are performed with peak and/or average measurements as necessary.
2. Peak measurements: RBW = 1MHz, VBW = 3 MHz, Sweep: Auto.
3. Average measurements: RBW = 1MHz, VBW = 10 Hz, Sweep: Auto.
4. “ * ”, means this data is the worst emission level.
5. Measurement Level = Reading Level + Correct Factor.
6. The average measurement was not performed when the peak measured data under the limit of average detection.

Product : Wireless Motherboard
 Test Item : Band Edge Data
 Test Site : No.3 OATS
 Test Mode : Mode 3: Transmit (802.11n-40BW 30Mbps) -Channel 102

RF Radiated Measurement:

	Frequency (MHz)	Correct Factor (dB)	Reading Level (dBm)	Measure Level (dBm/m)	Margin (dB)	Limit (dBm/m)	Result
Horizontal	5470.000	14.189	-77.690	-63.501	-36.501	-27.000	Pass

	Frequency (MHz)	Correct Factor (dB)	Reading Level (dBm)	Measure Level (dBm/m)	Margin (dB)	Limit (dBm/m)	Result
Vertical	5470.000	13.630	-72.810	-59.180	-32.180	-27.000	Pass

Product : Wireless Motherboard
 Test Item : Band Edge Data
 Test Site : No.3 OATS
 Test Mode : Mode 3: Transmit (802.11n-40BW 30Mbps) -Channel 134

RF Radiated Measurement:

	Frequency (MHz)	Correct Factor (dB)	Reading Level (dBm)	Measure Level (dBm/m)	Margin (dB)	Limit (dBm/m)	Result
Horizontal	5725.000	14.557	-78.900	-64.343	-37.343	-27.000	Pass

	Frequency (MHz)	Correct Factor (dB)	Reading Level (dBm)	Measure Level (dBm/m)	Margin (dB)	Limit (dBm/m)	Result
Vertical	5725.000	14.292	-78.340	-64.048	-37.048	-27.000	Pass

Product : Wireless Motherboard
 Test Item : Band Edge Data
 Test Site : No.3 OATS
 Test Mode : Mode 1: Transmit (802.11a-6Mbps)

Test Frequency (MHz)	Measurement Level (20dB BW) (MHz)	Limit (MHz)	Result
5580	5589.35	<5600	PASS
5660	5650.60	>5650	PASS

NOTE: The 5600~5650MHz band is not used in accordance with 15.215 requirement.
 5580MHz



5660MHz

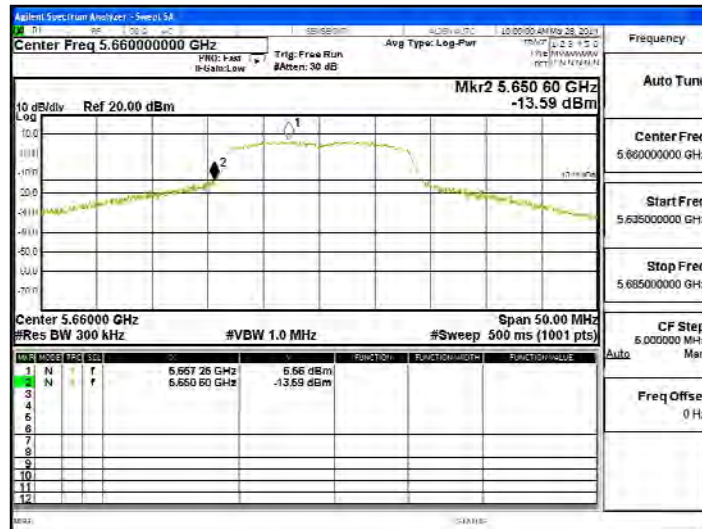

Product : Wireless Motherboard
 Test Item : Band Edge Data
 Test Site : No.3 OATS
 Test Mode : Mode 2: Transmit (802.11n-20BW 14.4Mbps)

Chain A

Test Frequency (MHz)	Measurement Level (20dB BW) (MHz)	Limit (MHz)	Result
5580	5589.60	<5600	PASS
5660	5650.40	>5650	PASS

NOTE: The 5600~5650MHz band is not used in accordance with 15.215 requirement.

5580MHz

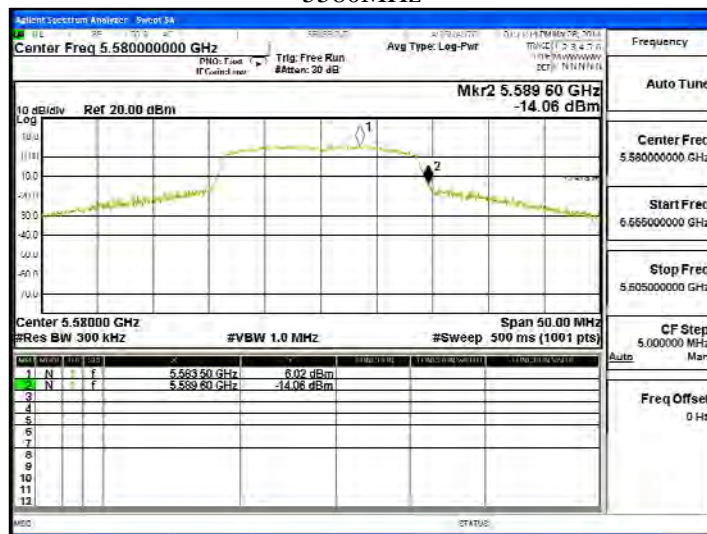

5660MHz

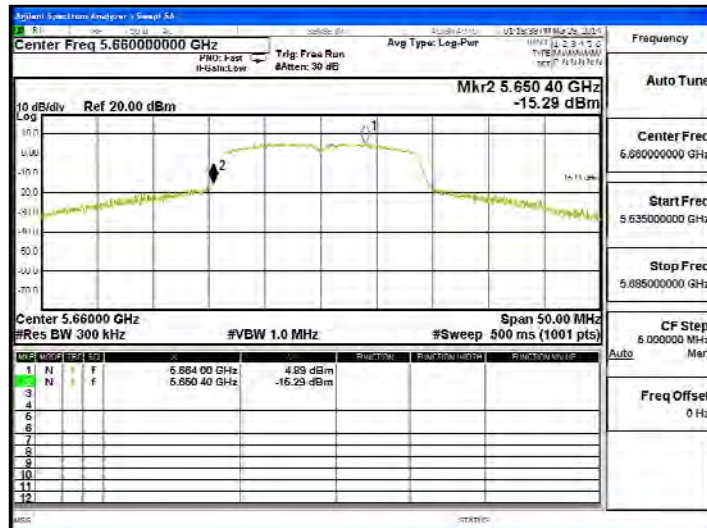

Product : Wireless Motherboard
 Test Item : Band Edge Data
 Test Site : No.3 OATS
 Test Mode : Mode 2: Transmit (802.11n-20BW 14.4Mbps)

Chain B

Test Frequency (MHz)	Measurement Level (20dB BW) (MHz)	Limit (MHz)	Result
5580	5589.70	<5600	PASS
5660	5650.95	>5650	PASS

NOTE: The 5600~5650MHz band is not used in accordance with 15.215 requirement.
 5580MHz

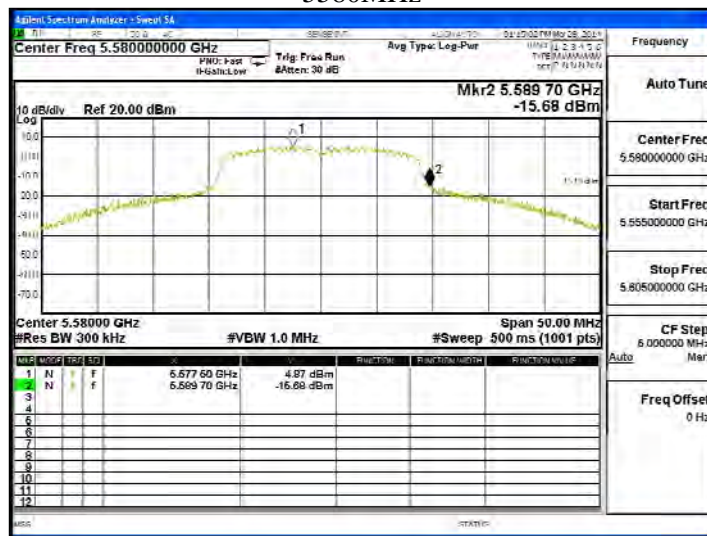

5660MHz

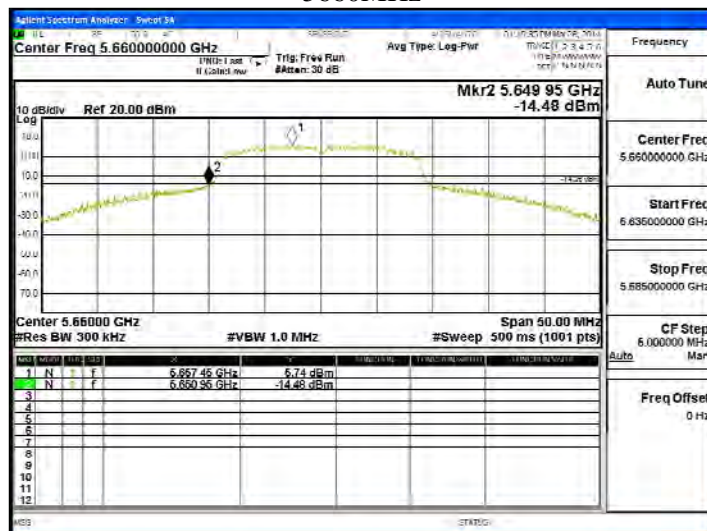

Product : Wireless Motherboard
 Test Item : Band Edge Data
 Test Site : No.3 OATS
 Test Mode : Mode 3: Transmit (802.11n-40BW 30Mbps)

Chain A

Test Frequency (MHz)	Measurement Level (20dB BW) (MHz)	Limit (MHz)	Result
5550	5569.50	<5600	PASS
5670	5650.20	>5650	PASS

NOTE: The 5600~5650MHz band is not used in accordance with 15.215 requirement.

5550MHz

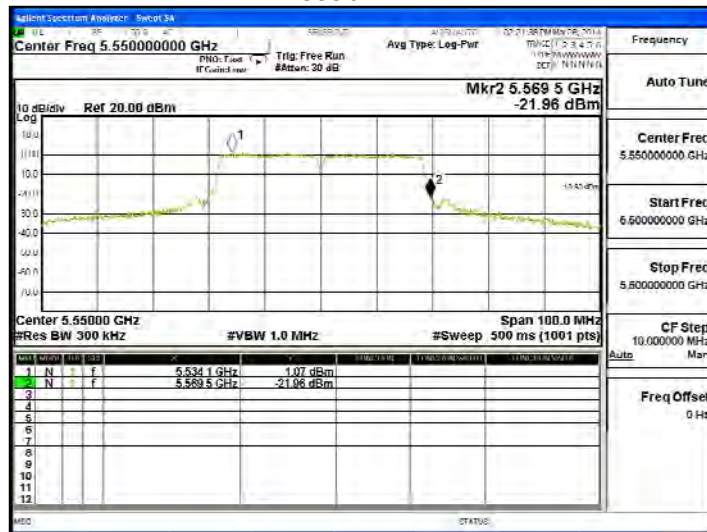

5670MHz

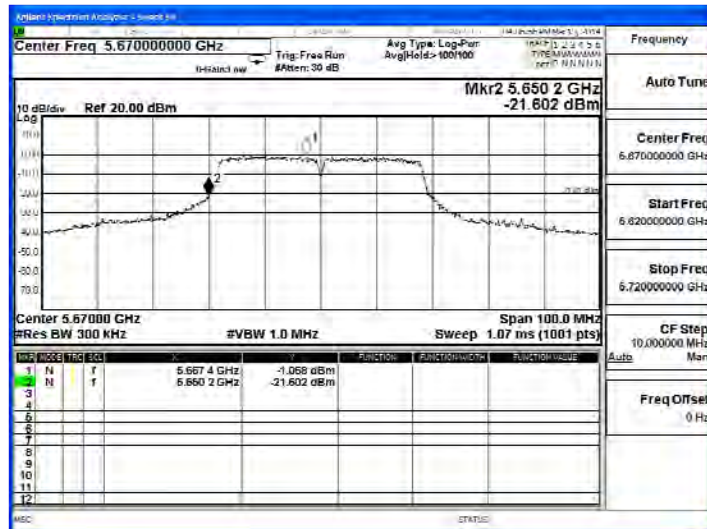

Product : Wireless Motherboard
 Test Item : Band Edge Data
 Test Site : No.3 OATS
 Test Mode : Mode 3: Transmit (802.11n-40BW 30Mbps)

Chain B

Test Frequency (MHz)	Measurement Level (20dB BW) (MHz)	Limit (MHz)	Result
5550	5569.10	<5600	PASS
5670	5650.30	>5650	PASS

NOTE: The 5600~5650MHz band is not used in accordance with 15.215 requirement.
 5550MHz

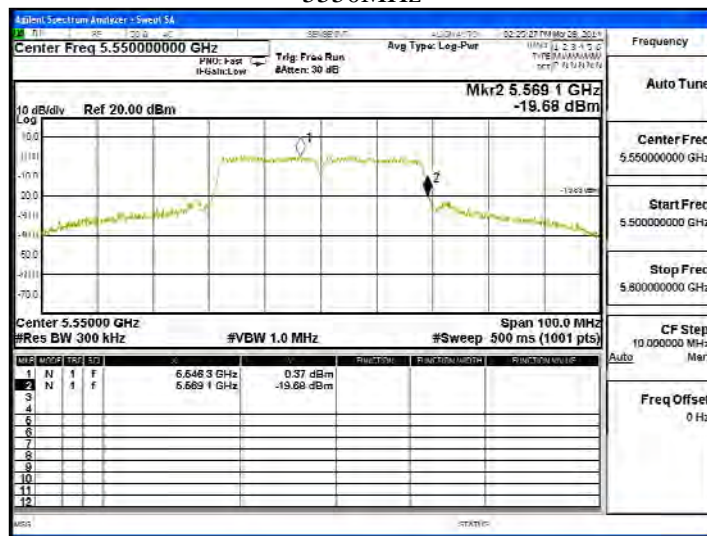

5670MHz

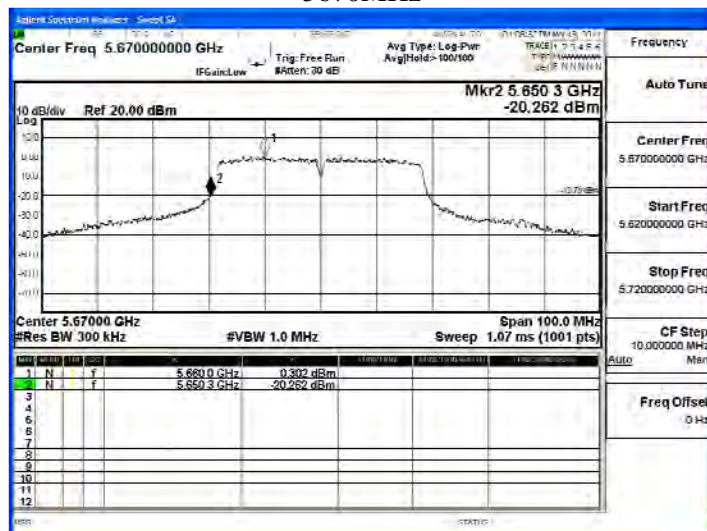

8. Frequency Stability

8.1. Test Equipment

	Equipment	Manufacturer	Model No./Serial No.	Last Cal.
	Spectrum Analyzer	R&S	FSP40 / 100170	Jun, 2013
	Spectrum Analyzer	Agilent	E4407B / US39440758	Jun, 2013
X	Spectrum Analyzer	Agilent	N9010A / MY48030495	Apr., 2014

Note:

1. All equipments are calibrated with traceable calibrations. Each calibration is traceable to the national or international standards.
2. The test instruments marked with “X” are used to measure the final test results.

8.2. Test Setup

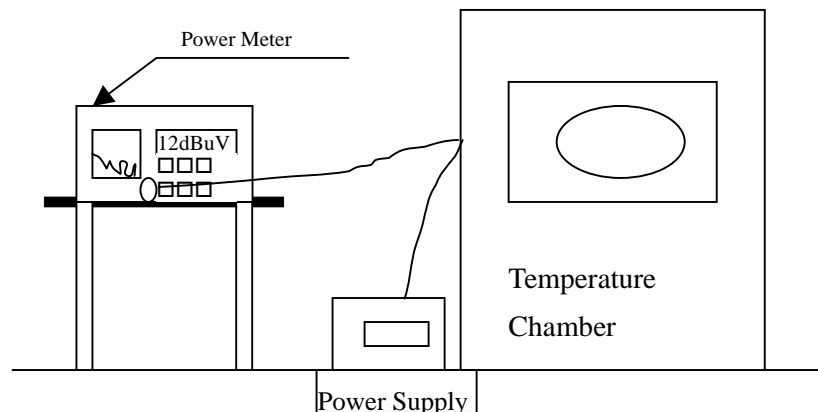

8.3. Limits

Manufactures of U-NII devices are responsible for ensuring frequency stability such that an emission is maintained within the band of operation under all conditions of normal operation as specified

8.4. Test Procedure

The EUT was setup to ANSI C63.10, 2009; tested to DTS test procedure of FCC KDB-789033 for compliance to FCC 47CFR Subpart E requirements.

8.5. Uncertainty

± 150 Hz

8.6. Test Result of Frequency Stability

Product : Wireless Motherboard
 Test Item : Frequency Stability
 Test Site : Temperature Chamber
 Test Mode : Carrier Wave

Chain A

Test Conditions		Channel	Frequency (MHz)	Frequency (MHz)	ΔF (MHz)
Tnom (20) °C	Vnom (120)V	36	5180.0000	5180.0068	-0.0068
		38	5190.0000	5190.0043	-0.0043
		44	5220.0000	5220.0082	-0.0082
		46	5230.0000	5230.0069	-0.0069
		48	5240.0000	5240.0077	-0.0077
		52	5260.0000	5260.0088	-0.0088
		54	5270.0000	5270.0081	-0.0081
		60	5300.0000	5300.0062	-0.0062
		62	5310.0000	5310.0058	-0.0058
		64	5320.0000	5320.0032	-0.0032
		100	5500.0000	5500.0093	-0.0093
		102	5510.0000	5510.0102	-0.0102
		110	5550.0000	5550.0100	-0.0100
		116	5580.0000	5580.0097	-0.0097
		134	5670.0000	5670.0082	-0.0082
140	5700.0000	5700.0087	-0.0087		
Tmax (50) °C	Vmax (138)V	36	5180.0000	5180.0070	-0.0070
		38	5190.0000	5190.0040	-0.0040
		44	5220.0000	5220.0080	-0.0080
		46	5230.0000	5230.0070	-0.0070
		48	5240.0000	5240.0071	-0.0071
		52	5260.0000	5260.0083	-0.0083
		54	5270.0000	5270.0079	-0.0079
		60	5300.0000	5300.0062	-0.0062
		62	5310.0000	5310.0088	-0.0088
		64	5320.0000	5320.0073	-0.0073
		100	5500.0000	5500.0074	-0.0074
		102	5510.0000	5510.0069	-0.0069
		110	5550.0000	5550.0100	-0.0100
		116	5580.0000	5580.0094	-0.0094
		134	5670.0000	5670.0081	-0.0081
140	5700.0000	5700.0077	-0.0077		

Tmax (50) °C	Vmin (102)V	36	5180.0000	5180.0069	-0.0069
		38	5190.0000	5190.0077	-0.0077
		44	5220.0000	5220.0088	-0.0088
		46	5230.0000	5230.0074	-0.0074
		48	5240.0000	5240.0066	-0.0066
		52	5260.0000	5260.0079	-0.0079
		54	5270.0000	5270.0092	-0.0092
		60	5300.0000	5300.0086	-0.0086
		62	5310.0000	5310.0061	-0.0061
		64	5320.0000	5320.0074	-0.0074
		100	5500.0000	5500.0073	-0.0073
		102	5510.0000	5510.0079	-0.0079
		110	5550.0000	5550.0099	-0.0099
		116	5580.0000	5580.0101	-0.0101
		134	5670.0000	5670.0088	-0.0088
140	5700.0000	5700.0080	-0.0080		
Tmin (-10) °C	Vmax (138)V	36	5180.0000	5180.0064	-0.0064
		38	5190.0000	5190.0078	-0.0078
		44	5220.0000	5220.0094	-0.0094
		46	5230.0000	5230.0077	-0.0077
		48	5240.0000	5240.0082	-0.0082
		52	5260.0000	5260.0076	-0.0076
		54	5270.0000	5270.0093	-0.0093
		60	5300.0000	5300.0084	-0.0084
		62	5310.0000	5310.0097	-0.0097
		64	5320.0000	5320.0100	-0.0100
		100	5500.0000	5500.0067	-0.0067
		102	5510.0000	5510.0074	-0.0074
		110	5550.0000	5550.0088	-0.0088
		116	5580.0000	5580.0094	-0.0094
		134	5670.0000	5670.0084	-0.0084
140	5700.0000	5700.0086	-0.0086		

Tmin (-10) °C	Vmin (102)V	36	5180.0000	5180.0064	-0.0064
		38	5190.0000	5190.0078	-0.0078
		44	5220.0000	5220.0094	-0.0094
		46	5230.0000	5230.0077	-0.0077
		48	5240.0000	5240.0082	-0.0082
		52	5260.0000	5260.0076	-0.0076
		54	5270.0000	5270.0093	-0.0093
		60	5300.0000	5300.0084	-0.0084
		62	5310.0000	5310.0097	-0.0097
		64	5320.0000	5320.0100	-0.0100
		100	5500.0000	5500.0067	-0.0067
		102	5510.0000	5510.0074	-0.0074
		110	5550.0000	5550.0088	-0.0088
		116	5580.0000	5580.0094	-0.0094
		134	5670.0000	5670.0084	-0.0084
		140	5700.0000	5700.0086	-0.0086

Chain B

Test Conditions		Channel	Frequency (MHz)	Frequency (MHz)	ΔF (MHz)
Tnom (20) °C	Vnom (120)V	36	5180.0000	5180.0065	-0.0065
		38	5190.0000	5190.0040	-0.0040
		44	5220.0000	5220.0077	-0.0077
		46	5230.0000	5230.0067	-0.0067
		48	5240.0000	5240.0074	-0.0074
		52	5260.0000	5260.0084	-0.0084
		54	5270.0000	5270.0077	-0.0077
		60	5300.0000	5300.0059	-0.0059
		62	5310.0000	5310.0057	-0.0057
		64	5320.0000	5320.0030	-0.0030
		100	5500.0000	5500.0090	-0.0090
		102	5510.0000	5510.0100	-0.0100
		110	5550.0000	5550.0098	-0.0098
		116	5580.0000	5580.0096	-0.0096
		134	5670.0000	5670.0080	-0.0080
140	5700.0000	5700.0086	-0.0086		
Tmax (50) °C	Vmax (138)V	36	5180.0000	5180.0069	-0.0069
		38	5190.0000	5190.0041	-0.0041
		44	5220.0000	5220.0077	-0.0077
		46	5230.0000	5230.0069	-0.0069
		48	5240.0000	5240.0064	-0.0064
		52	5260.0000	5260.0078	-0.0078
		54	5270.0000	5270.0073	-0.0073
		60	5300.0000	5300.0060	-0.0060
		62	5310.0000	5310.0080	-0.0080
		64	5320.0000	5320.0069	-0.0069
		100	5500.0000	5500.0071	-0.0071
		102	5510.0000	5510.0061	-0.0061
		110	5550.0000	5550.0097	-0.0097
		116	5580.0000	5580.0093	-0.0093
		134	5670.0000	5670.0080	-0.0080
140	5700.0000	5700.0074	-0.0074		

Tmax (50) °C	Vmin (102)V	36	5180.0000	5180.0063	-0.0063
		38	5190.0000	5190.0074	-0.0074
		44	5220.0000	5220.0087	-0.0087
		46	5230.0000	5230.0070	-0.0070
		48	5240.0000	5240.0063	-0.0063
		52	5260.0000	5260.0077	-0.0077
		54	5270.0000	5270.0090	-0.0090
		60	5300.0000	5300.0084	-0.0084
		62	5310.0000	5310.0060	-0.0060
		64	5320.0000	5320.0072	-0.0072
		100	5500.0000	5500.0072	-0.0072
		102	5510.0000	5510.0077	-0.0077
		110	5550.0000	5550.0097	-0.0097
		116	5580.0000	5580.0099	-0.0099
		134	5670.0000	5670.0087	-0.0087
140	5700.0000	5700.0079	-0.0079		
Tmin (-10) °C	Vmax (138)V	36	5180.0000	5180.0061	-0.0061
		38	5190.0000	5190.0077	-0.0077
		44	5220.0000	5220.0091	-0.0091
		46	5230.0000	5230.0077	-0.0077
		48	5240.0000	5240.0080	-0.0080
		52	5260.0000	5260.0071	-0.0071
		54	5270.0000	5270.0090	-0.0090
		60	5300.0000	5300.0081	-0.0081
		62	5310.0000	5310.0094	-0.0094
		64	5320.0000	5320.0094	-0.0094
		100	5500.0000	5500.0065	-0.0065
		102	5510.0000	5510.0071	-0.0071
		110	5550.0000	5550.0087	-0.0087
		116	5580.0000	5580.0092	-0.0092
		134	5670.0000	5670.0083	-0.0083
140	5700.0000	5700.0085	-0.0085		

Tmin (-10) °C	Vmin (102)V	36	5180.0000	5180.6300	-0.6300
		38	5190.0000	5190.0075	-0.0075
		44	5220.0000	5220.0084	-0.0084
		46	5230.0000	5230.0080	-0.0080
		48	5240.0000	5240.0087	-0.0087
		52	5260.0000	5260.0075	-0.0075
		54	5270.0000	5270.0089	-0.0089
		60	5300.0000	5300.7700	-0.7700
		62	5310.0000	5310.0090	-0.0090
		64	5320.0000	5320.0097	-0.0097
		100	5500.0000	5500.0079	-0.0079
		102	5510.0000	5510.0066	-0.0066
		110	5550.0000	5550.0074	-0.0074
		116	5580.0000	5580.0089	-0.0089
		134	5670.0000	5670.0077	-0.0077
		140	5700.0000	5700.0086	-0.0086

9. EMI Reduction Method During Compliance Testing

No modification was made during testing.