



FCC TEST REPORT (WLAN 15.407)

REPORT NO.: RF131126D16A-1
MODEL NO.: TR10Cxy
FCC ID: WL6-TRBC1CD1
RECEIVED: Dec. 18, 2013
TESTED: Dec. 19, 2013 ~ Jan. 16, 2014
ISSUED: Jan. 17, 2014

APPLICANT: Elitegroup Computer Systems Co., Ltd
ADDRESS: No. 239, Ti Ding Blvd., Sec. 2, Taipei, Taiwan 11493

ISSUED BY: Bureau Veritas Consumer Products Services
(H.K.) Ltd., Taoyuan Branch

LAB ADDRESS: No. 47, 14th Ling, Chia Pau Vil., Lin Kou Dist.,
New Taipei City, Taiwan

This report should not be used by the client to claim product certification, approval, or endorsement by TAF or any government agencies.



This report is for your exclusive use. Any copying or replication of this report to or for any other person or entity, or use of our name or trademark, is permitted only with our prior written permission. This report sets forth our findings solely with respect to the test samples identified herein. The results set forth in this report are not indicative or representative of the quality or characteristics of the lot from which a test sample was taken or any similar or identical product unless specifically and expressly noted. Our report includes all of the tests requested by you and the results thereof based upon the information that you provided to us. You have 60 days from date of issuance of this report to notify us of any material error or omission caused by our negligence, provided, however, that such notice shall be in writing and shall specifically address the issue you wish to raise. A failure to raise such issue within the prescribed time shall constitute your unqualified acceptance of the completeness of this report, the tests conducted and the correctness of the report contents. Unless specific mention, the uncertainty of measurement has been explicitly taken into account to declare the compliance or non-compliance to the specification



TABLE OF CONTENTS

RELEASE CONTROL RECORD	4
1. CERTIFICATION	5
2. SUMMARY OF TEST RESULTS.....	6
2.1 MEASUREMENT UNCERTAINTY	6
3. GENERAL INFORMATION	7
3.1 GENERAL DESCRIPTION OF EUT	7
3.2 DESCRIPTION OF TEST MODES	9
3.2.1 TEST MODE APPLICABILITY AND TESTED CHANNEL DETAIL	10
3.3 DUTY CYCLE OF TEST SIGNAL	12
3.4 DESCRIPTION OF SUPPORT UNITS.....	14
3.4.1 CONFIGURATION OF SYSTEM UNDER TEST	14
3.5 GENERAL DESCRIPTION OF APPLIED STANDARDS	14
4. TEST TYPES AND RESULTS.....	16
4.1 RADIATED EMISSION AND BANDEDGE MEASUREMENT	16
4.1.1 LIMITS OF RADIATED EMISSION AND BANDEDGE MEASUREMENT	16
4.1.2 LIMITS OF UNWANTED EMISSION OUT OF THE RESTRICTED BANDS... ..	16
4.1.3 TEST INSTRUMENTS	17
4.1.4 TEST PROCEDURES.....	18
4.1.5 DEVIATION FROM TEST STANDARD	18
4.1.6 TEST SETUP	19
4.1.7 EUT OPERATING CONDITION	19
4.1.8 TEST RESULTS.....	20
4.2 CONDUCTED EMISSION MEASUREMENT	33
4.2.1 LIMITS OF CONDUCTED EMISSION MEASUREMENT	33
4.2.2 TEST INSTRUMENTS	33
4.2.3 TEST PROCEDURES.....	34
4.2.4 DEVIATION FROM TEST STANDARD	34
4.2.5 TEST SETUP	35
4.2.6 EUT OPERATING CONDITIONS.....	35
4.2.7 TEST RESULTS.....	36
4.3 PEAK TRANSMIT POWER MEASUREMENT	38
4.3.1 LIMITS OF PEAK TRANSMIT POWER MEASUREMENT	38
4.3.2 TEST SETUP	38
4.3.3 TEST INSTRUMENTS	38
4.3.4 TEST PROCEDURE	39
4.3.5 DEVIATION FROM TEST STANDARD	39
4.3.6 EUT OPERATING CONDITIONS.....	39
4.3.7 TEST RESULTS.....	40
4.4 PEAK POWER SPECTRAL DENSITY MEASUREMENT	43
4.4.1 LIMITS OF PEAK POWER SPECTRAL DENSITY MEASUREMENT	43
4.4.2 TEST SETUP	43
4.4.3 TEST INSTRUMENTS	43
4.4.4 TEST PROCEDURES.....	43
4.4.5 DEVIATION FROM TEST STANDARD	43



4.4.6	EUT OPERATING CONDITIONS.....	43
4.4.7	TEST RESULTS.....	44
4.5	PEAK POWER EXCURSION MEASUREMENT.....	45
4.5.1	LIMITS OF PEAK POWER EXCURSION MEASUREMENT	45
4.5.2	TEST SETUP	45
4.5.3	TEST INSTRUMENTS	45
4.5.4	TEST PROCEDURE	45
4.5.5	DEVIATION FROM TEST STANDARD	45
4.5.6	EUT OPERATING CONDITIONS.....	45
4.5.7	TEST RESULTS.....	46
4.6	FREQUENCY STABILITY	47
4.6.1	LIMITS OF FREQUENCY STABILITY MEASUREMENT	47
4.6.2	TEST SETUP	47
4.6.3	TEST INSTRUMENTS	47
4.6.4	TEST PROCEDURE	48
4.6.5	DEVIATION FROM TEST STANDARD	48
4.6.6	EUT OPERATING CONDITION	48
4.6.7	TEST RESULTS.....	49
5.	PHOTOGRAPHS OF THE TEST CONFIGURATION	50
6.	INFORMATION ON THE TESTING LABORATORIES.....	51
7.	APPENDIX A - MODIFICATIONS RECORDERS FOR ENGINEERING CHANGES TO THE EUT BY THE LAB.....	52



A D T

RELEASE CONTROL RECORD

ISSUE NO.	REASON FOR CHANGE	DATE ISSUED
RF131126D16A-1	Original release	Jan. 17, 2014



1. CERTIFICATION

PRODUCT: Wireless Motherboard

BRAND: ECS ELITEGROUP

MODEL: TR10Cxy (x=0~9, A~Z or blank or "-";y=0~9, A~Z or blank or "-")

APPLICANT: Elitegroup Computer Systems Co., Ltd

TESTED: Dec. 19, 2013 ~ Jan. 16, 2014

TEST SAMPLE: ENGINEERING SAMPLE

STANDARDS: FCC Part 15, Subpart E (Section 15.407)

ANSI C63.10-2009

The above equipment (Model: TR10CD1) has been tested by **Bureau Veritas Consumer Products Services (H.K.) Ltd., Taoyuan Branch**, and found compliance with the requirement of the above standards. The test record, data evaluation & Equipment Under Test (EUT) configurations represented herein are true and accurate accounts of the measurements of the sample's EMC characteristics under the conditions specified in this report.

PREPARED BY : Annie Chang , **DATE:** Jan. 17, 2014
(Annie Chang / Supervisor)

APPROVED BY : Rex Lai , **DATE:** Jan. 17, 2014
(Rex Lai / Assistant Manager)

2. SUMMARY OF TEST RESULTS

The EUT has been tested according to the following specifications:

APPLIED STANDARD: FCC PART 15, SUBPART E (SECTION 15.407)			
STANDARD SECTION	TEST TYPE	RESULT	REMARK
15.407(b)(6)	AC Power Conducted Emission	PASS	Meet the requirement of limit. Minimum passing margin is -20.54dB at 11.98438MHz.
15.407(b/1/2/3) (b)(6)	Radiated Emissions	PASS	Meet the requirement of limit. Minimum passing margin is -2.0dB at 5150.00MHz.
15.407(a/1/2)	Max Average Transmit Power	PASS	Meet the requirement of limit.
15.407(a)(6)	Peak Power Excursion	PASS	Meet the requirement of limit.
15.407(a/1/2)	Peak Power Spectral Density	PASS	Meet the requirement of limit.
15.407(g)	Frequency Stability	PASS	Meet the requirement of limit.
15.203	Antenna Requirement	PASS	No antenna connector is used.

2.1 MEASUREMENT UNCERTAINTY

Where relevant, the following measurement uncertainty levels have been estimated for tests performed on the EUT as specified in CISPR 16-4-2:

MEASUREMENT	FREQUENCY	UNCERTAINTY
Conducted emissions	150kHz~30MHz	2.41 dB
Radiated emissions	30MHz ~ 1GHz	4.30 dB
	Above 1GHz	3.36 dB

This uncertainty represents an expanded uncertainty expressed at approximately the 95% confidence level using a coverage factor of $k = 2$.

3. GENERAL INFORMATION

3.1 GENERAL DESCRIPTION OF EUT

EUT	Wireless Motherboard
MODEL NO.	TR10Cxy
POWER SUPPLY	5Vdc from AC adapter or 3.7V from Battery
MODULATION TYPE	64QAM, 16QAM, QPSK, BPSK
MODULATION TECHNOLOGY	OFDM
TRANSFER RATE	802.11a: 54.0/ 48.0/ 36.0/ 24.0/ 18.0/ 12.0/ 9.0/ 6.0Mbps 802.11n: up to 72Mbps
OPERATING FREQUENCY	5180 ~ 5240MHz, 5260 ~ 5320MHz
NUMBER OF CHANNEL	5180 ~ 5240MHz: 4 5260 ~ 5320MHz: 4
OUTPUT POWER	9.3mW for 5180 ~ 5240MHz 8.4mW for 5260 ~ 5320MHz
ANTENNA TYPE	Ceramic Chip antenna with 4.2dBi gain
ANTENNA CONNECTOR	N/A
DATA CABLE	N/A
I/O PORTS	Refer to user's manual
ACCESSORY DEVICES	Refer to note below

NOTE:

1. The EUT is a Wireless Motherboard with a 802.11abgn & Bluetooth 4.0 Combo module (Brand: BROADCOM, Model: BCM4330X).
2. The "x & y" in the model could be defined as 0~9, A~Z or blank for marketing differentiation. During the test, model: **TR10CD1** was selected as the representative one and therefore only its test data was recorded in this report.
3. The EUT incorporates a SISO function. Physically, the EUT provides one completed transmitter and one receiver.

Modulation Mode	Tx Function
802.11b	1TX
802.11g	1TX
802.11a	1TX
802.11n (20MHz)	1TX

4. The EUT consumes power from an AC adapter or battery, as follows:

Item	Brand	Model No.	Spec.
Adapter	Hunkey	HKA01005020-3H	AC I/P: 1100-240V, 0.5A, 50/60Hz DC O/P: 5V, 2A AC 2 Pin. Non-shielded DC cable (1.5m)
Battery 1	Sunwoda	LI8100	3.7Vdc, 8100mAh
Battery 2	Sunwoda	LI6300	3.7Vdc, 6300mAh

After pre-tested, the worst emission level was found when the EUT was tested under **Adapter with Battery 1** mode, therefore, only its test data was recorded in this report.

5. For Radiated Emissions test, following modes were pre-tested:

- ◆ EUT + Adapter
- ◆ EUT only

The worst emission level was found when the EUT was tested under **EUT + Adapter** mode, therefore, only its test data was recorded in this report.

1. The frequency bands used in this EUT are listed as follows:

Frequency Band (MHz)	2412~2462	5180~5320	5745~5825
802.11b	√		
802.11g	√		
802.11a		√	√
802.11n (20MHz)	√	√	√

2. The above EUT information is declared by manufacturer and for more detailed features description, please refer to the manufacturer's specifications or user's manual.

3.2 DESCRIPTION OF TEST MODES

FOR 5180 ~ 5240MHz

4 channels are provided for 802.11a, 802.11n (20MHz):

CHANNEL	FREQUENCY	CHANNEL	FREQUENCY
36	5180 MHz	44	5220 MHz
40	5200 MHz	48	5240 MHz

FOR 5260 ~ 5320MHz

4 channels are provided for 802.11a, 802.11n (20MHz):

CHANNEL	FREQUENCY	CHANNEL	FREQUENCY
52	5260 MHz	60	5300 MHz
56	5280 MHz	64	5320 MHz

3.2.1 TEST MODE APPLICABILITY AND TESTED CHANNEL DETAIL

EUT CONFIGURE MODE	APPLICABLE TO				DESCRIPTION
	RE≥1G	RE<1G	PLC	APCM	
-	√	√	√	√	-

Where **RE≥1G**: Radiated Emission above 1GHz **RE<1G**: Radiated Emission below 1GHz
PLC: Power Line Conducted Emission **APCM**: Antenna Port Conducted Measurement

NOTE: The EUT had been pre-tested on the positioned of 3 axis. The worst case was found when positioned on **X-plane**.

RADIATED EMISSION TEST (ABOVE 1GHz):

- Pre-Scan has been conducted to determine the worst-case mode from all possible combinations between available modulations, data rates and antenna ports (if EUT with antenna diversity architecture).
- Following channel(s) was (were) selected for the final test as listed below.

EUT CONFIGURE MODE	MODE	FREQ. BAND (MHz)	AVAILABLE CHANNEL	TESTED CHANNEL	MODULATION TECHNOLOGY	MODULATION TYPE	DATA RATE (Mbps)
-	802.11a	5180-5240	36 to 48	36, 40, 48	OFDM	BPSK	6.0
-	802.11n (20MHz)		36 to 48	36, 40, 48	OFDM	BPSK	6.5
-	802.11a	5260-5320	52 to 64	52, 60, 64	OFDM	BPSK	6.0
-	802.11n (20MHz)		52 to 64	52, 60, 64	OFDM	BPSK	6.5

RADIATED EMISSION TEST (BELOW 1GHz):

- Pre-Scan has been conducted to determine the worst-case mode from all possible combinations between available modulations, data rates and antenna ports (if EUT with antenna diversity architecture).
- Following channel(s) was (were) selected for the final test as listed below.

EUT CONFIGURE MODE	MODE	FREQ. BAND (MHz)	AVAILABLE CHANNEL	TESTED CHANNEL	MODULATION TECHNOLOGY	MODULATION TYPE	DATA RATE (Mbps)
-	802.11n (20MHz)	5260-5320	52 to 64	52	OFDM	BPSK	6.5

POWER LINE CONDUCTED EMISSION TEST:

- Pre-Scan has been conducted to determine the worst-case mode from all possible combinations between available modulations, data rates and antenna ports (if EUT with antenna diversity architecture).
- Following channel(s) was (were) selected for the final test as listed below.

EUT CONFIGURE MODE	MODE	FREQ. BAND (MHz)	AVAILABLE CHANNEL	TESTED CHANNEL	MODULATION TECHNOLOGY	MODULATION TYPE	DATA RATE (Mbps)
-	802.11n (20MHz)	5260-5320	52 to 64	52	OFDM	BPSK	6.5



ANTENNA PORT CONDUCTED MEASUREMENT:

- This item includes all test value of each mode, but only includes spectrum plot of worst value of each mode.
- Pre-Scan has been conducted to determine the worst-case mode from all possible combinations between available modulations, data rates and antenna ports (if EUT with antenna diversity architecture).
- Following channel(s) was (were) selected for the final test as listed below.

EUT CONFIGURE MODE	MODE	FREQ. BAND (MHz)	AVAILABLE CHANNEL	TESTED CHANNEL	MODULATION TECHNOLOGY	MODULATION TYPE	DATA RATE (Mbps)
-	802.11a	5180-5240	36 to 48	36, 40, 48	OFDM	BPSK	6.0
-	802.11n (20MHz)		36 to 48	36, 40, 48	OFDM	BPSK	6.5
-	802.11a	5260-5320	52 to 64	52, 60, 64	OFDM	BPSK	6.0
-	802.11n (20MHz)		52 to 64	52, 60, 64	OFDM	BPSK	6.5

TEST CONDITION:

APPLICABLE TO	ENVIRONMENTAL CONDITIONS	INPUT POWER	TESTED BY
RE≥1G	21deg. C, 75%RH	120Vac, 60Hz	Joey Liu
RE<1G	21deg. C, 75%RH	120Vac, 60Hz	Joey Liu
PLC	23deg. C, 75% RH	120Vac, 60Hz	Joey Liu
APCM	25deg. C, 60% RH	120Vac, 60Hz	Dalen Dai



3.3 DUTY CYCLE OF TEST SIGNAL

If duty cycle is < 98%, duty factor shall be considered.

802.11a:

BPSK: Duty cycle = 2.060 / 2.380 = 0.866 , Duty factor = 10 * log(1/ 0.866) = 0.62

QPSK: Duty cycle = 1.048 / 1.080 = 0.970 , Duty factor = 10 * log(1/ 0.970) = 0.13

16QAM: Duty cycle = 0.534 / 0.566 = 0.943 , Duty factor = 10 * log(1/ 0.943) = 0.25

64QAM: Duty cycle = 0.276 / 0.308 = 0.896 , Duty factor = 10 * log(1/ 0.896) = 0.48

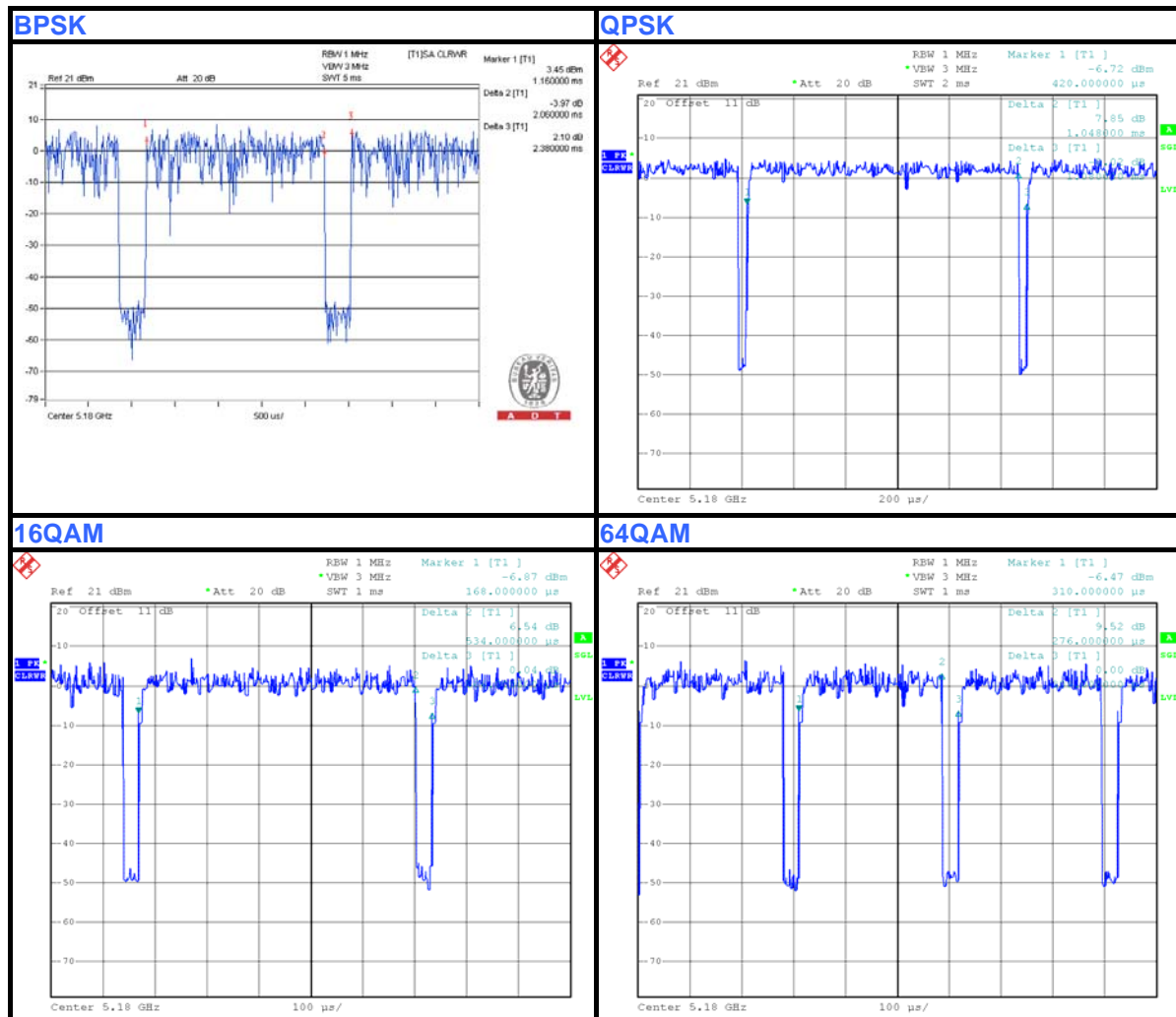



A D T

802.11n (20MHz)

BPSK: Duty cycle = $1.910 / 2.230 = 0.857$, Duty factor = $10 * \log(1 / 0.857) = 0.67$

QPSK: Duty cycle = $0.668 / 0.700 = 0.954$, Duty factor = $10 * \log(1 / 0.954) = 0.20$

16QAM: Duty cycle = $0.350 / 0.382 = 0.916$, Duty factor = $10 * \log(1 / 0.916) = 0.38$

64QAM: Duty cycle = $0.246 / 0.278 = 0.885$, Duty factor = $10 * \log(1 / 0.885) = 0.53$

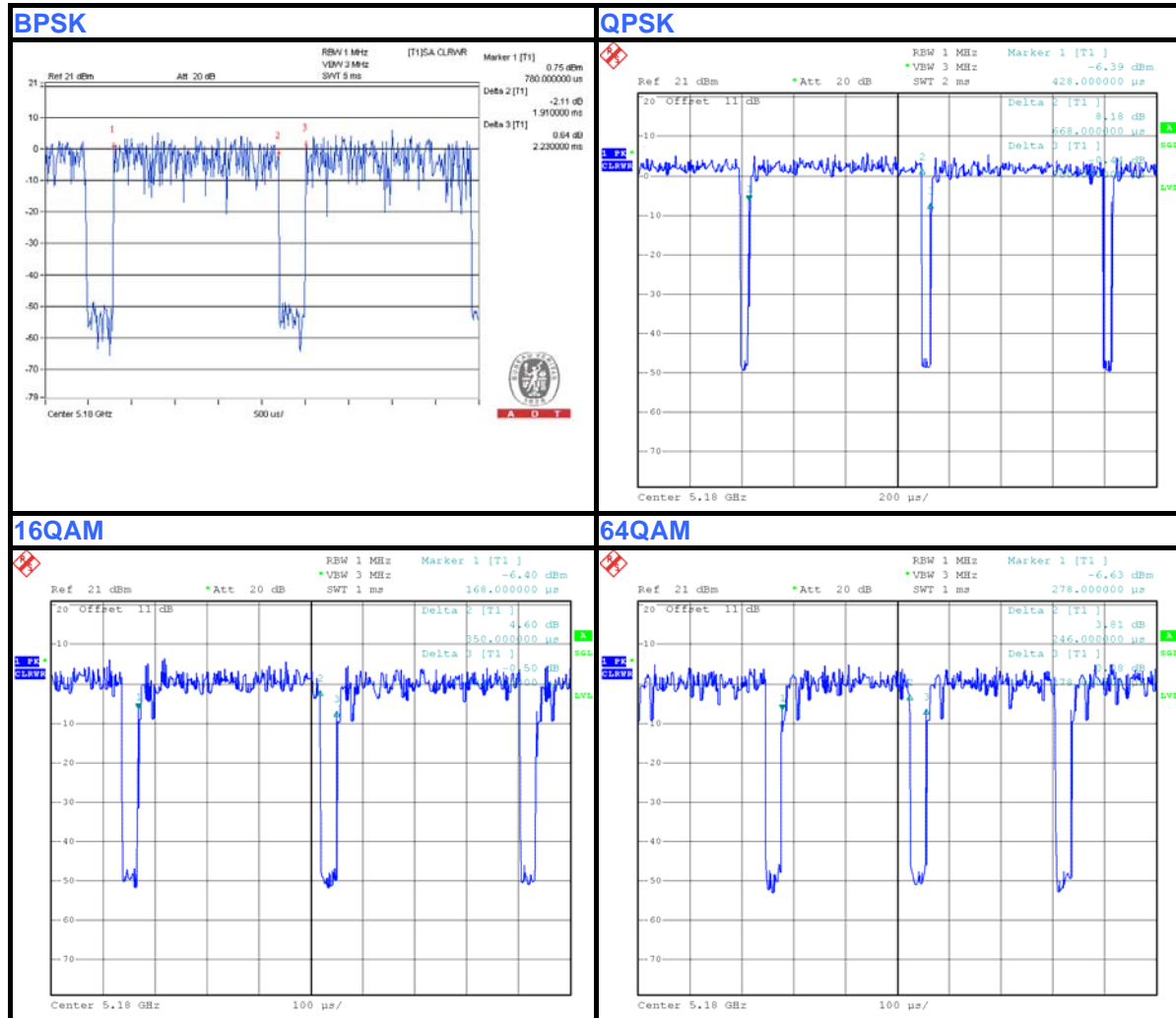

3.4 DESCRIPTION OF SUPPORT UNITS

The EUT has been tested as an independent unit together with other necessary accessories or support units. The following support units or accessories were used to form a representative test configuration during the tests.

NO.	PRODUCT	BRAND	MODEL NO.	SERIAL NO.	FCC ID
1	NOTEBOOK COMPUTER	DELL	510m	1KZ1G1S	FCC DoC Approved

NO.	SIGNAL CABLE DESCRIPTION OF THE ABOVE SUPPORT UNITS
1	0.4m shielded USB cable

NOTE: All power cords of the above support units are non shielded (1.8m).

3.4.1 CONFIGURATION OF SYSTEM UNDER TEST

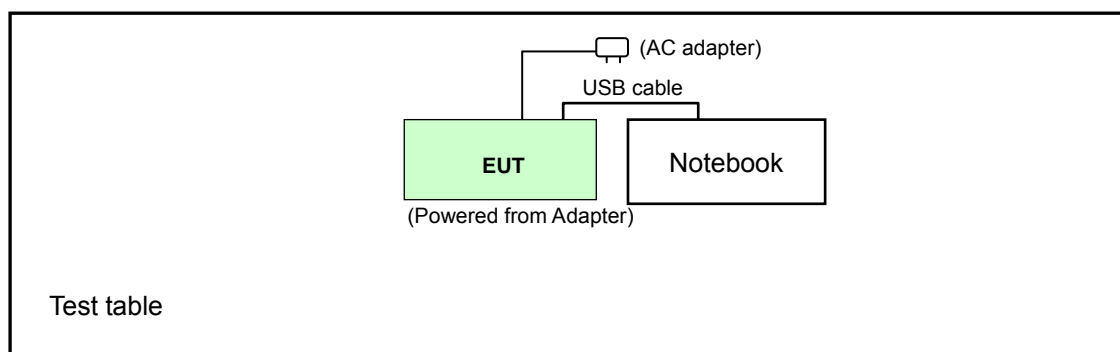



3.5 GENERAL DESCRIPTION OF APPLIED STANDARDS

The EUT is a RF Product. According to the specifications of the manufacturer, it must comply with the requirements of the following standards:

FCC Part 15, Subpart E (15.407)

789033 D01 General UNII Test Procedures v01 r03

662911 D01 Multiple Transmitter Output v02

ANSI C63.10-2009

All test items have been performed and recorded as per the above standards.

4. TEST TYPES AND RESULTS

4.1 RADIATED EMISSION AND BANDEDGE MEASUREMENT

4.1.1 LIMITS OF RADIATED EMISSION AND BANDEDGE MEASUREMENT

Radiated emissions which fall in the restricted bands must comply with the radiated emission limits specified as below table:

FREQUENCIES (MHz)	FIELD STRENGTH (microvolts/meter)	MEASUREMENT DISTANCE (meters)
0.009 ~ 0.490	2400/F(kHz)	300
0.490 ~ 1.705	24000/F(kHz)	30
1.705 ~ 30.0	30	30
30 ~ 88	100	3
88 ~ 216	150	3
216 ~ 960	200	3
Above 960	500	3

NOTE:

1. The lower limit shall apply at the transition frequencies.
2. Emission level (dBuV/m) = 20 log Emission level (uV/m).
3. For frequencies above 1000MHz, the field strength limits are based on average detector, however, the peak field strength of any emission shall not exceed the maximum permitted average limits, specified above by more than 20dB under any condition of modulation.

4.1.2 LIMITS OF UNWANTED EMISSION OUT OF THE RESTRICTED BANDS

APPLICABLE TO	LIMIT	
√	FIELD STRENGTH AT 3m (dBμV/m)	
	PK	AV
	74	54
	EIRP LIMIT (dBm)	EQUIVALENT FIELD STRENGTH AT 3m (dBμV/m)
	PK	PK
	-27	68.3

NOTE: The following formula is used to convert the equipment isotropic radiated power (eirp) to field strength:

$$E = \frac{1000000\sqrt{30P}}{3} \mu\text{V/m, where P is the eirp (Watts).}$$



4.1.3 TEST INSTRUMENTS

DESCRIPTION & MANUFACTURER	MODEL NO.	SERIAL NO.	CALIBRATED DATE	CALIBRATED UNTIL
HP Preamplifier	8447D	2432A03504	Feb. 26, 2013	Feb. 25, 2014
HP Preamplifier	8449B	3008A01201	Feb. 26, 2013	Feb. 25, 2014
Agilent TEST RECEIVER	N9038A	MY51210129	Jan. 03, 2013	Jan. 02, 2014
Schwarzbeck Antenna	VULB 9168	137	Mar. 20, 2013	Mar. 19, 2014
Schwarzbeck Antenna	VHBA 9123	480	May 29, 2013	May 28, 2014
ADT. Turn Table	TT100	0306	NA	NA
ADT. Tower	AT100	0306	NA	NA
Software	ADT_Radiated_V 7.6.15.9.2	NA	NA	NA
SUHNER RF cable	SF102	CABLE-CH6	Aug. 19, 2013	Aug. 18, 2014
Schwarzbeck Horn Antenna	BBHA 9120-D1	D130	May 13, 2013	May 12, 2014
Highpass filter Wainwright Instruments	WHK 3.1/18G-10SS	SN 8	NA	NA
ROHDE & SCHWARZ Spectrum Analyzer	FSP 40	100036	May. 17, 2013	May. 16, 2014
Anritsu Power Sensor	MA2411B	0738404	Apr. 24, 2013	Apr. 23, 2014
Anritsu Power Meter	ML2495A	0842014	Apr. 25, 2013	Apr. 24, 2014

- NOTE:**
1. The calibration interval of the above test instruments is 12/24 months. And the calibrations are traceable to NML/ROC and NIST/USA.
 2. The horn antenna and HP preamplifier (model: 8449B) are used only for the measurement of emission frequency above 1GHz if tested.
 3. The test was performed in Chamber No. 6.
 4. The Industry Canada Reference No. IC 7450E-6.
 5. The FCC Site Registration No. is 447212.

4.1.4 TEST PROCEDURES

- a. The EUT was placed on the top of a rotating table 0.8 meters above the ground at a 3 meter semi-anechoic chamber. The table was rotated 360 degrees to determine the position of the highest radiation.
- b. The EUT was set 3 meters away from the interference-receiving antenna, which was mounted on the top of a variable-height antenna tower.
- c. The antenna is a broadband antenna, and its height is varied from one meter to four meters above the ground to determine the maximum value of the field strength. Both horizontal and vertical polarizations of the antenna are set to make the measurement.
- d. For each suspected emission, the EUT was arranged to its worst case and then the antenna was tuned to heights from 1 meter to 4 meters and the rotatable table was turned from 0 degrees to 360 degrees to find the maximum reading.
- e. The test-receiver system was set to Peak Detect Function and Specified Bandwidth with Maximum Hold Mode.
- f. If the emission level of the EUT in peak mode was 10dB lower than the limit specified, then testing could be stopped and the peak values of the EUT would be reported. Otherwise the emissions that did not have 10dB margin would be re-tested one by one using peak, quasi-peak or average method as specified and then reported in a data sheet.

NOTE:

1. The resolution bandwidth and video bandwidth of test receiver/spectrum analyzer is 120kHz for Peak detection (PK) and Quasi-peak detection (QP) at frequency below 1GHz.
2. The resolution bandwidth of test receiver/spectrum analyzer is 1MHz and video bandwidth is 3MHz for Peak detection at frequency above 1GHz.
3. The resolution bandwidth of test receiver/spectrum analyzer is 1MHz and the video bandwidth is $\geq 1/T$ (Duty cycle < 98%) or 10Hz (Duty cycle > 98%) for Average detection (AV) at frequency above 1GHz. All modes of operation were investigated and the worst-case emissions are reported.

4.1.5 DEVIATION FROM TEST STANDARD

No deviation.

4.1.6 TEST SETUP

Frequency range 30MHz~1GHz

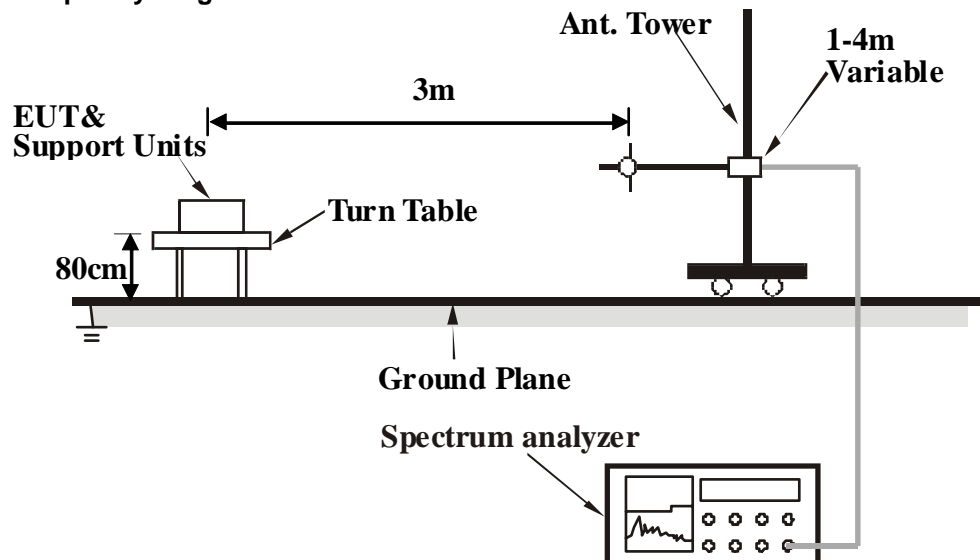

Frequency range above 1GHz

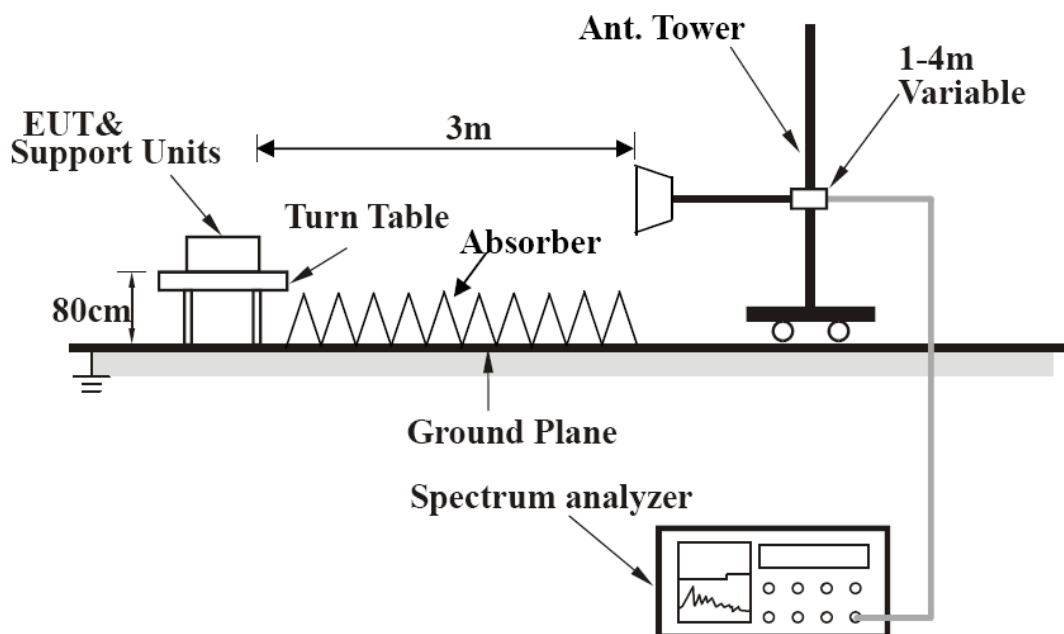

For the actual test configuration, please refer to the attached file (Test Setup Photo).

4.1.7 EUT OPERATING CONDITION

- Connected the EUT to AC adapter.
- The Notebook connected with EUT via a USBH cable and run a test program (provided by manufacturer) to enable EUT under transmission condition continuously at specific channel frequency.

4.1.8 TEST RESULTS

ABOVE 1GHz DATA

802.11a

CHANNEL	TX Channel 36	DETECTOR FUNCTION	Peak (PK)
FREQUENCY RANGE	1GHz ~ 40GHz		Average (AV)

ANTENNA POLARITY & TEST DISTANCE: HORIZONTAL AT 3 M								
NO.	FREQ. (MHz)	EMISSION LEVEL (dBuV/m)	LIMIT (dBuV/m)	MARGIN (dB)	ANTENNA HEIGHT (m)	TABLE ANGLE (Degree)	RAW VALUE (dBuV)	CORRECTION FACTOR (dB/m)
1	5150.00	65.1 PK	74.0	-8.9	1.00 H	151	61.07	4.05
2	5150.00	43.4 AV	54.0	-10.6	1.00 H	151	39.32	4.05
3	*5180.00	102.2 PK			1.00 H	151	98.07	4.14
4	*5180.00	91.5 AV			1.00 H	151	87.39	4.14
5	10360.00	55.6 PK	74.0	-18.4	1.00 H	151	40.88	14.73
6	10360.00	41.4 AV	54.0	-12.6	1.00 H	151	26.71	14.73
ANTENNA POLARITY & TEST DISTANCE: VERTICAL AT 3 M								
NO.	FREQ. (MHz)	EMISSION LEVEL (dBuV/m)	LIMIT (dBuV/m)	MARGIN (dB)	ANTENNA HEIGHT (m)	TABLE ANGLE (Degree)	RAW VALUE (dBuV)	CORRECTION FACTOR (dB/m)
1	5150.00	72.0 PK	74.0	-2.0	1.00 V	174	67.98	4.05
2	5150.00	48.7 AV	54.0	-5.3	1.00 V	174	44.67	4.05
3	*5180.00	108.1 PK			1.00 V	174	103.93	4.14
4	*5180.00	97.6 AV			1.00 V	174	93.46	4.14
5	10360.00	62.8 PK	74.0	-11.3	1.00 V	179	48.02	14.73
6	10360.00	49.5 AV	54.0	-4.5	1.00 V	179	34.78	14.73

REMARKS:

1. Emission Level(dBuV/m) = Raw Value(dBuV) + Correction Factor(dB/m)
2. Correction Factor(dB/m) = Antenna Factor(dB/m) + Cable Factor(dB) – Pre-Amplifier Factor(dB)
3. The other emission levels were very low against the limit.
4. Margin value = Emission Level – Limit value
5. " * ": Fundamental frequency.

CHANNEL	TX Channel 40	DETECTOR FUNCTION	Peak (PK)
FREQUENCY RANGE	1GHz ~ 40GHz		Average (AV)

ANTENNA POLARITY & TEST DISTANCE: HORIZONTAL AT 3 M								
NO.	FREQ. (MHz)	EMISSION LEVEL (dBuV/m)	LIMIT (dBuV/m)	MARGIN (dB)	ANTENNA HEIGHT (m)	TABLE ANGLE (Degree)	RAW VALUE (dBuV)	CORRECTION FACTOR (dB/m)
1	*5200.00	101.1 PK			1.00 H	152	96.87	4.19
2	*5200.00	91.1 AV			1.00 H	152	86.95	4.19
3	10400.00	55.5 PK	74.0	-18.5	1.00 H	156	40.41	15.12
4	10400.00	41.4 AV	54.0	-12.6	1.00 H	156	26.27	15.12
ANTENNA POLARITY & TEST DISTANCE: VERTICAL AT 3 M								
NO.	FREQ. (MHz)	EMISSION LEVEL (dBuV/m)	LIMIT (dBuV/m)	MARGIN (dB)	ANTENNA HEIGHT (m)	TABLE ANGLE (Degree)	RAW VALUE (dBuV)	CORRECTION FACTOR (dB/m)
1	*5200.00	110.4 PK			1.00 V	173	106.17	4.19
2	*5200.00	98.8 AV			1.00 V	173	94.56	4.19
3	10400.00	66.0 PK	74.0	-8.0	1.00 V	176	50.92	15.12
4	10400.00	48.8 AV	54.0	-5.2	1.00 V	176	33.71	15.12

REMARKS:

1. Emission Level(dBuV/m) = Raw Value(dBuV) + Correction Factor(dB/m)
2. Correction Factor(dB/m) = Antenna Factor(dB/m) + Cable Factor(dB) – Pre-Amplifier Factor(dB)
3. The other emission levels were very low against the limit.
4. Margin value = Emission Level – Limit value
5. " * ": Fundamental frequency.

CHANNEL	TX Channel 48	DETECTOR FUNCTION	Peak (PK)
FREQUENCY RANGE	1GHz ~ 40GHz		Average (AV)

ANTENNA POLARITY & TEST DISTANCE: HORIZONTAL AT 3 M								
NO.	FREQ. (MHz)	EMISSION LEVEL (dBuV/m)	LIMIT (dBuV/m)	MARGIN (dB)	ANTENNA HEIGHT (m)	TABLE ANGLE (Degree)	RAW VALUE (dBuV)	CORRECTION FACTOR (dB/m)
1	*5240.00	101.6 PK			1.00 H	163	97.21	4.35
2	*5240.00	91.5 AV			1.00 H	163	87.11	4.35
3	10480.00	56.3 PK	74.0	-17.7	1.00 H	164	41.41	14.92
4	10480.00	41.6 AV	54.0	-12.4	1.00 H	164	26.69	14.92
ANTENNA POLARITY & TEST DISTANCE: VERTICAL AT 3 M								
NO.	FREQ. (MHz)	EMISSION LEVEL (dBuV/m)	LIMIT (dBuV/m)	MARGIN (dB)	ANTENNA HEIGHT (m)	TABLE ANGLE (Degree)	RAW VALUE (dBuV)	CORRECTION FACTOR (dB/m)
1	*5240.00	109.0 PK			1.00 V	175	104.68	4.35
2	*5240.00	98.3 AV			1.00 V	175	93.91	4.35
3	10480.00	63.3 PK	74.0	-10.7	1.00 V	175	48.34	14.92
4	10480.00	47.0 AV	54.0	-7.0	1.00 V	175	32.06	14.92

REMARKS:

1. Emission Level(dBuV/m) = Raw Value(dBuV) + Correction Factor(dB/m)
2. Correction Factor(dB/m) = Antenna Factor(dB/m) + Cable Factor(dB) – Pre-Amplifier Factor(dB)
3. The other emission levels were very low against the limit.
4. Margin value = Emission Level – Limit value
5. " * ": Fundamental frequency.

CHANNEL	TX Channel 52	DETECTOR FUNCTION	Peak (PK)
FREQUENCY RANGE	1GHz ~ 40GHz		Average (AV)

ANTENNA POLARITY & TEST DISTANCE: HORIZONTAL AT 3 M								
NO.	FREQ. (MHz)	EMISSION LEVEL (dBuV/m)	LIMIT (dBuV/m)	MARGIN (dB)	ANTENNA HEIGHT (m)	TABLE ANGLE (Degree)	RAW VALUE (dBuV)	CORRECTION FACTOR (dB/m)
1	*5260.00	102.7 PK			1.00 H	162	98.29	4.42
2	*5260.00	91.1 AV			1.00 H	162	86.67	4.42
3	10520.00	56.1 PK	74.0	-17.9	1.00 H	168	41.12	14.98
4	10520.00	41.7 AV	54.0	-12.3	1.00 H	168	26.76	14.98
ANTENNA POLARITY & TEST DISTANCE: VERTICAL AT 3 M								
NO.	FREQ. (MHz)	EMISSION LEVEL (dBuV/m)	LIMIT (dBuV/m)	MARGIN (dB)	ANTENNA HEIGHT (m)	TABLE ANGLE (Degree)	RAW VALUE (dBuV)	CORRECTION FACTOR (dB/m)
1	*5260.00	108.5 PK			1.00 V	187	104.06	4.42
2	*5260.00	98.0 AV			1.00 V	187	93.53	4.42
3	10520.00	63.4 PK	74.0	-10.7	1.00 V	189	48.37	14.98
4	10520.00	47.5 AV	54.0	-6.6	1.00 V	189	32.47	14.98

REMARKS:

1. Emission Level(dBuV/m) = Raw Value(dBuV) + Correction Factor(dB/m)
2. Correction Factor(dB/m) = Antenna Factor(dB/m) + Cable Factor(dB) – Pre-Amplifier Factor(dB)
3. The other emission levels were very low against the limit.
4. Margin value = Emission Level – Limit value
5. " * ": Fundamental frequency.

CHANNEL	TX Channel 60	DETECTOR FUNCTION	Peak (PK)
FREQUENCY RANGE	1GHz ~ 40GHz		Average (AV)

ANTENNA POLARITY & TEST DISTANCE: HORIZONTAL AT 3 M								
NO.	FREQ. (MHz)	EMISSION LEVEL (dBuV/m)	LIMIT (dBuV/m)	MARGIN (dB)	ANTENNA HEIGHT (m)	TABLE ANGLE (Degree)	RAW VALUE (dBuV)	CORRECTION FACTOR (dB/m)
1	*5300.00	102.1 PK			1.00 H	159	97.56	4.58
2	*5300.00	91.4 AV			1.00 H	159	86.81	4.58
3	10600.00	55.5 PK	74.0	-18.5	1.00 H	163	40.07	15.41
4	10600.00	42.0 AV	54.0	-12.0	1.00 H	163	26.56	15.41
ANTENNA POLARITY & TEST DISTANCE: VERTICAL AT 3 M								
NO.	FREQ. (MHz)	EMISSION LEVEL (dBuV/m)	LIMIT (dBuV/m)	MARGIN (dB)	ANTENNA HEIGHT (m)	TABLE ANGLE (Degree)	RAW VALUE (dBuV)	CORRECTION FACTOR (dB/m)
1	*5300.00	109.4 PK			1.00 V	188	104.77	4.58
2	*5300.00	97.8 AV			1.00 V	188	93.26	4.58
3	10600.00	63.7 PK	74.0	-10.3	1.00 V	192	48.31	15.41
4	10600.00	48.3 AV	54.0	-5.8	1.00 V	192	32.84	15.41

REMARKS:

1. Emission Level(dBuV/m) = Raw Value(dBuV) + Correction Factor(dB/m)
2. Correction Factor(dB/m) = Antenna Factor(dB/m) + Cable Factor(dB) – Pre-Amplifier Factor(dB)
3. The other emission levels were very low against the limit.
4. Margin value = Emission Level – Limit value
5. " * ": Fundamental frequency.

CHANNEL	TX Channel 64	DETECTOR FUNCTION	Peak (PK)
FREQUENCY RANGE	1GHz ~ 40GHz		Average (AV)

ANTENNA POLARITY & TEST DISTANCE: HORIZONTAL AT 3 M

NO.	FREQ. (MHz)	EMISSION LEVEL (dBuV/m)	LIMIT (dBuV/m)	MARGIN (dB)	ANTENNA HEIGHT (m)	TABLE ANGLE (Degree)	RAW VALUE (dBuV)	CORRECTION FACTOR (dB/m)
1	*5320.00	102.7 PK			1.00 H	160	98.03	4.63
2	*5320.00	91.9 AV			1.00 H	160	87.23	4.63
3	5350.00	66.2 PK	74.0	-7.8	1.00 H	160	61.46	4.71
4	5350.00	44.8 AV	54.0	-9.2	1.00 H	160	40.10	4.71
5	10640.00	55.6 PK	74.0	-18.4	1.00 H	162	40.27	15.35
6	10640.00	42.3 AV	54.0	-11.7	1.00 H	162	26.95	15.35

ANTENNA POLARITY & TEST DISTANCE: VERTICAL AT 3 M

NO.	FREQ. (MHz)	EMISSION LEVEL (dBuV/m)	LIMIT (dBuV/m)	MARGIN (dB)	ANTENNA HEIGHT (m)	TABLE ANGLE (Degree)	RAW VALUE (dBuV)	CORRECTION FACTOR (dB/m)
1	*5320.00	107.9 PK			1.00 V	187	103.27	4.63
2	*5320.00	97.8 AV			1.00 V	187	93.17	4.63
3	5350.00	71.3 PK	74.0	-2.7	1.00 V	187	66.61	4.71
4	5350.00	48.3 AV	54.0	-5.7	1.00 V	187	43.62	4.71
5	10640.00	63.0 PK	74.0	-11.0	1.00 V	189	47.69	15.35
6	10640.00	47.7 AV	54.0	-6.3	1.00 V	189	32.36	15.35

REMARKS:

1. Emission Level(dBuV/m) = Raw Value(dBuV) + Correction Factor(dB/m)
2. Correction Factor(dB/m) = Antenna Factor(dB/m) + Cable Factor(dB) – Pre-Amplifier Factor(dB)
3. The other emission levels were very low against the limit.
4. Margin value = Emission Level – Limit value
5. " * ": Fundamental frequency.

802.11n (20MHz)

CHANNEL	TX Channel 36	DETECTOR FUNCTION	Peak (PK)
FREQUENCY RANGE	1GHz ~ 40GHz		Average (AV)

ANTENNA POLARITY & TEST DISTANCE: HORIZONTAL AT 3 M								
NO.	FREQ. (MHz)	EMISSION LEVEL (dBuV/m)	LIMIT (dBuV/m)	MARGIN (dB)	ANTENNA HEIGHT (m)	TABLE ANGLE (Degree)	RAW VALUE (dBuV)	CORRECTION FACTOR (dB/m)
1	5150.00	61.3 PK	74.0	-12.7	1.00 H	149	57.23	4.05
2	5150.00	40.7 AV	54.0	-13.3	1.00 H	149	36.63	4.05
3	*5180.00	103.8 PK			1.00 H	149	99.65	4.14
4	*5180.00	82.9 AV			1.00 H	149	78.72	4.14
5	10360.00	54.5 PK	74.0	-19.5	1.00 H	155	39.77	14.73
6	10360.00	41.0 AV	54.0	-13.0	1.00 H	155	26.26	14.73
ANTENNA POLARITY & TEST DISTANCE: VERTICAL AT 3 M								
NO.	FREQ. (MHz)	EMISSION LEVEL (dBuV/m)	LIMIT (dBuV/m)	MARGIN (dB)	ANTENNA HEIGHT (m)	TABLE ANGLE (Degree)	RAW VALUE (dBuV)	CORRECTION FACTOR (dB/m)
1	5150.00	69.4 PK	74.0	-4.6	1.01 V	184	65.32	4.05
2	5150.00	43.3 AV	54.0	-10.8	1.01 V	184	39.20	4.05
3	*5180.00	109.1 PK			1.01 V	184	104.95	4.14
4	*5180.00	87.7 AV			1.01 V	184	83.51	4.14
5	10360.00	62.8 PK	74.0	-11.2	1.00 V	183	48.09	14.73
6	10360.00	43.3 AV	54.0	-10.7	1.00 V	183	28.58	14.73

REMARKS:

1. Emission Level(dBuV/m) = Raw Value(dBuV) + Correction Factor(dB/m)
2. Correction Factor(dB/m) = Antenna Factor(dB/m) + Cable Factor(dB) – Pre-Amplifier Factor(dB)
3. The other emission levels were very low against the limit.
4. Margin value = Emission Level – Limit value
5. " * ": Fundamental frequency.

CHANNEL	TX Channel 40	DETECTOR FUNCTION	Peak (PK)
FREQUENCY RANGE	1GHz ~ 40GHz		Average (AV)

ANTENNA POLARITY & TEST DISTANCE: HORIZONTAL AT 3 M								
NO.	FREQ. (MHz)	EMISSION LEVEL (dBuV/m)	LIMIT (dBuV/m)	MARGIN (dB)	ANTENNA HEIGHT (m)	TABLE ANGLE (Degree)	RAW VALUE (dBuV)	CORRECTION FACTOR (dB/m)
1	*5200.00	102.8 PK			1.00 H	149	98.61	4.19
2	*5200.00	82.3 AV			1.00 H	149	78.09	4.19
3	10400.00	53.8 PK	74.0	-20.2	1.00 H	153	38.71	15.12
4	10400.00	40.4 AV	54.0	-13.6	1.00 H	153	25.24	15.12
ANTENNA POLARITY & TEST DISTANCE: VERTICAL AT 3 M								
NO.	FREQ. (MHz)	EMISSION LEVEL (dBuV/m)	LIMIT (dBuV/m)	MARGIN (dB)	ANTENNA HEIGHT (m)	TABLE ANGLE (Degree)	RAW VALUE (dBuV)	CORRECTION FACTOR (dB/m)
1	*5200.00	109.4 PK			1.02 V	185	105.23	4.19
2	*5200.00	88.1 AV			1.02 V	185	83.95	4.19
3	10400.00	63.2 PK	74.0	-10.8	1.02 V	188	48.06	15.12
4	10400.00	43.3 AV	54.0	-10.7	1.02 V	188	28.19	15.12

REMARKS:

1. Emission Level(dBuV/m) = Raw Value(dBuV) + Correction Factor(dB/m)
2. Correction Factor(dB/m) = Antenna Factor(dB/m) + Cable Factor(dB) – Pre-Amplifier Factor(dB)
3. The other emission levels were very low against the limit.
4. Margin value = Emission Level – Limit value
5. " * ": Fundamental frequency.

CHANNEL	TX Channel 48	DETECTOR FUNCTION	Peak (PK)
FREQUENCY RANGE	1GHz ~ 40GHz		Average (AV)

ANTENNA POLARITY & TEST DISTANCE: HORIZONTAL AT 3 M								
NO.	FREQ. (MHz)	EMISSION LEVEL (dBuV/m)	LIMIT (dBuV/m)	MARGIN (dB)	ANTENNA HEIGHT (m)	TABLE ANGLE (Degree)	RAW VALUE (dBuV)	CORRECTION FACTOR (dB/m)
1	*5240.00	103.9 PK			1.00 H	163	99.59	4.35
2	*5240.00	82.9 AV			1.00 H	163	78.58	4.35
3	10480.00	54.3 PK	74.0	-19.7	1.00 H	166	39.39	14.92
4	10480.00	42.4 AV	54.0	-11.6	1.00 H	166	27.49	14.92
ANTENNA POLARITY & TEST DISTANCE: VERTICAL AT 3 M								
NO.	FREQ. (MHz)	EMISSION LEVEL (dBuV/m)	LIMIT (dBuV/m)	MARGIN (dB)	ANTENNA HEIGHT (m)	TABLE ANGLE (Degree)	RAW VALUE (dBuV)	CORRECTION FACTOR (dB/m)
1	*5240.00	110.5 PK			1.01 V	186	106.12	4.35
2	*5240.00	88.4 AV			1.01 V	186	84.07	4.35
3	10480.00	63.8 PK	74.0	-10.2	1.00 V	190	48.91	14.92
4	10480.00	44.1 AV	54.0	-9.9	1.00 V	190	29.16	14.92

REMARKS:

1. Emission Level(dBuV/m) = Raw Value(dBuV) + Correction Factor(dB/m)
2. Correction Factor(dB/m) = Antenna Factor(dB/m) + Cable Factor(dB) – Pre-Amplifier Factor(dB)
3. The other emission levels were very low against the limit.
4. Margin value = Emission Level – Limit value
5. " * ": Fundamental frequency.

CHANNEL	TX Channel 52	DETECTOR FUNCTION	Peak (PK)
FREQUENCY RANGE	1GHz ~ 40GHz		Average (AV)

ANTENNA POLARITY & TEST DISTANCE: HORIZONTAL AT 3 M								
NO.	FREQ. (MHz)	EMISSION LEVEL (dBuV/m)	LIMIT (dBuV/m)	MARGIN (dB)	ANTENNA HEIGHT (m)	TABLE ANGLE (Degree)	RAW VALUE (dBuV)	CORRECTION FACTOR (dB/m)
1	*5260.00	103.4 PK			1.03 H	55	98.95	4.42
2	*5260.00	93.2 AV			1.03 H	55	88.74	4.42
3	10520.00	55.5 PK	74.0	-18.5	1.03 H	59	40.52	14.98
4	10520.00	40.7 AV	54.0	-13.3	1.03 H	59	25.71	14.98
ANTENNA POLARITY & TEST DISTANCE: VERTICAL AT 3 M								
NO.	FREQ. (MHz)	EMISSION LEVEL (dBuV/m)	LIMIT (dBuV/m)	MARGIN (dB)	ANTENNA HEIGHT (m)	TABLE ANGLE (Degree)	RAW VALUE (dBuV)	CORRECTION FACTOR (dB/m)
1	*5260.00	109.1 PK			1.00 V	185	104.68	4.42
2	*5260.00	99.3 AV			1.00 V	185	94.86	4.42
3	10520.00	65.1 PK	74.0	-8.9	1.00 V	190	50.12	14.98
4	10520.00	48.8 AV	54.0	-5.2	1.00 V	190	33.79	14.98

REMARKS:

1. Emission Level(dBuV/m) = Raw Value(dBuV) + Correction Factor(dB/m)
2. Correction Factor(dB/m) = Antenna Factor(dB/m) + Cable Factor(dB) – Pre-Amplifier Factor(dB)
3. The other emission levels were very low against the limit.
4. Margin value = Emission Level – Limit value
5. " * ": Fundamental frequency.

CHANNEL	TX Channel 60	DETECTOR FUNCTION	Peak (PK)
FREQUENCY RANGE	1GHz ~ 40GHz		Average (AV)

ANTENNA POLARITY & TEST DISTANCE: HORIZONTAL AT 3 M								
NO.	FREQ. (MHz)	EMISSION LEVEL (dBuV/m)	LIMIT (dBuV/m)	MARGIN (dB)	ANTENNA HEIGHT (m)	TABLE ANGLE (Degree)	RAW VALUE (dBuV)	CORRECTION FACTOR (dB/m)
1	*5300.00	105.0 PK			1.03 H	56	100.41	4.58
2	*5300.00	94.9 AV			1.03 H	56	90.34	4.58
3	10600.00	57.6 PK	74.0	-16.4	1.03 H	58	42.21	15.41
4	10600.00	42.7 AV	54.0	-11.3	1.03 H	58	27.29	15.41
ANTENNA POLARITY & TEST DISTANCE: VERTICAL AT 3 M								
NO.	FREQ. (MHz)	EMISSION LEVEL (dBuV/m)	LIMIT (dBuV/m)	MARGIN (dB)	ANTENNA HEIGHT (m)	TABLE ANGLE (Degree)	RAW VALUE (dBuV)	CORRECTION FACTOR (dB/m)
1	*5300.00	109.7 PK			1.00 V	190	105.11	4.58
2	*5300.00	99.0 AV			1.00 V	190	94.39	4.58
3	10600.00	64.8 PK	74.0	-9.2	1.00 V	195	49.36	15.41
4	10600.00	48.8 AV	54.0	-5.3	1.00 V	195	33.34	15.41

REMARKS:

1. Emission Level(dBuV/m) = Raw Value(dBuV) + Correction Factor(dB/m)
2. Correction Factor(dB/m) = Antenna Factor(dB/m) + Cable Factor(dB) – Pre-Amplifier Factor(dB)
3. The other emission levels were very low against the limit.
4. Margin value = Emission Level – Limit value
5. " * ": Fundamental frequency.

CHANNEL	TX Channel 64	DETECTOR FUNCTION	Peak (PK)
FREQUENCY RANGE	1GHz ~ 40GHz		Average (AV)

ANTENNA POLARITY & TEST DISTANCE: HORIZONTAL AT 3 M								
NO.	FREQ. (MHz)	EMISSION LEVEL (dBuV/m)	LIMIT (dBuV/m)	MARGIN (dB)	ANTENNA HEIGHT (m)	TABLE ANGLE (Degree)	RAW VALUE (dBuV)	CORRECTION FACTOR (dB/m)
1	*5320.00	104.7 PK			1.02 H	56	100.05	4.63
2	*5320.00	94.8 AV			1.02 H	56	90.14	4.63
3	5350.00	68.9 PK	74.0	-5.1	1.02 H	56	64.18	4.71
4	5350.00	46.5 AV	54.0	-7.5	1.02 H	56	41.77	4.71
5	10640.00	56.9 PK	74.0	-17.1	1.02 H	61	41.59	15.35
6	10640.00	42.8 AV	54.0	-11.2	1.02 H	61	27.41	15.35
ANTENNA POLARITY & TEST DISTANCE: VERTICAL AT 3 M								
NO.	FREQ. (MHz)	EMISSION LEVEL (dBuV/m)	LIMIT (dBuV/m)	MARGIN (dB)	ANTENNA HEIGHT (m)	TABLE ANGLE (Degree)	RAW VALUE (dBuV)	CORRECTION FACTOR (dB/m)
1	*5320.00	110.3 PK			1.00 V	187	105.62	4.63
2	*5320.00	98.8 AV			1.00 V	187	94.12	4.63
3	5350.00	71.2 PK	74.0	-2.8	1.00 V	187	66.47	4.71
4	5350.00	49.4 AV	54.0	-4.7	1.00 V	187	44.64	4.71
5	10640.00	61.0 PK	74.0	-13.0	1.00 V	192	45.68	15.35
6	10640.00	46.7 AV	54.0	-7.3	1.00 V	192	31.38	15.35

REMARKS:

1. Emission Level(dBuV/m) = Raw Value(dBuV) + Correction Factor(dB/m)
2. Correction Factor(dB/m) = Antenna Factor(dB/m) + Cable Factor(dB) – Pre-Amplifier Factor(dB)
3. The other emission levels were very low against the limit.
4. Margin value = Emission Level – Limit value
5. " * ": Fundamental frequency.

BELOW 1GHz WORST-CASE DATA

802.11n (20MHz)

CHANNEL	TX Channel 52	DETECTOR FUNCTION	Quasi-Peak (QP)
FREQUENCY RANGE	30MHz ~ 1GHz		

ANTENNA POLARITY & TEST DISTANCE: HORIZONTAL AT 3 M

NO.	FREQ. (MHz)	EMISSION LEVEL (dBuV/m)	LIMIT (dBuV/m)	MARGIN (dB)	ANTENNA HEIGHT (m)	TABLE ANGLE (Degree)	RAW VALUE (dBuV)	CORRECTION FACTOR (dB/m)
1	82.33	32.1 QP	40.0	-8.0	1.35 H	22	50.57	-18.52
2	115.31	32.2 QP	43.5	-11.3	1.44 H	277	48.37	-16.14
3	199.90	35.5 QP	43.5	-8.1	1.67 H	92	51.39	-15.94
4	240.00	32.8 QP	46.0	-13.2	1.32 H	127	46.88	-14.06
5	298.69	29.7 QP	46.0	-16.3	1.16 H	202	41.24	-11.51
6	381.29	29.1 QP	46.0	-17.0	1.27 H	339	38.86	-9.81

ANTENNA POLARITY & TEST DISTANCE: VERTICAL AT 3 M

NO.	FREQ. (MHz)	EMISSION LEVEL (dBuV/m)	LIMIT (dBuV/m)	MARGIN (dB)	ANTENNA HEIGHT (m)	TABLE ANGLE (Degree)	RAW VALUE (dBuV)	CORRECTION FACTOR (dB/m)
1	42.51	32.4 QP	40.0	-7.6	1.53 V	23	46.53	-14.10
2	82.33	32.7 QP	40.0	-7.3	1.17 V	113	51.25	-18.52
3	166.58	35.5 QP	43.5	-8.1	1.52 V	4	48.98	-13.53
4	199.90	31.2 QP	43.5	-12.3	1.37 V	13	47.12	-15.94
5	384.15	28.3 QP	46.0	-17.8	1.25 V	58	38.10	-9.85
6	422.56	30.6 QP	46.0	-15.4	1.64 V	33	39.73	-9.09

REMARKS:

1. Emission Level(dBuV/m) = Raw Value(dBuV) + Correction Factor(dB/m)
2. Correction Factor(dB/m) = Antenna Factor(dB/m) + Cable Factor(dB) – Pre-Amplifier Factor(dB)
3. The other emission levels were very low against the limit.
4. Margin value = Emission Level – Limit value

4.2 CONDUCTED EMISSION MEASUREMENT

4.2.1 LIMITS OF CONDUCTED EMISSION MEASUREMENT

FREQUENCY OF EMISSION (MHz)	CONDUCTED LIMIT (dB μ V)	
	Quasi-peak	Average
0.15 ~ 0.5	66 to 56	56 to 46
0.5 ~ 5	56	46
5 ~ 30	60	50

- NOTE:** 1. The lower limit shall apply at the transition frequencies.
 2. The limit decreases in line with the logarithm of the frequency in the range of 0.15 to 0.50MHz.

4.2.2 TEST INSTRUMENTS

Description & Manufacturer	Model No.	Serial No.	Cal. Date	Cal. Due
ROHDE & SCHWARZ TEST RECEIVER	ESCS 30	100276	Jan. 07, 2014	Jan. 06, 2015
ROHDE & SCHWARZ Artificial Mains Network (for EUT)	ESH3-Z5	100219	Nov. 17, 2013	Nov. 16, 2014
LISN With Adapter (for EUT)	AD10	C10Ada-001	Nov. 17, 2013	Nov. 16, 2014
ROHDE & SCHWARZ Artificial Mains Network (for peripherals)	ESH3-Z5	100218	Nov. 25, 2013	Nov. 24, 2014
Software	ADT_Cond_V7.3.7	NA	NA	NA
Software	ADT_ISN_V7.3.7	NA	NA	NA
RF cable (JYEBAO)	5D-FB	Cable-C10.01	Feb. 19, 2013	Feb. 18, 2014
SUHNER Terminator (For ROHDE & SCHWARZ LISN)	65BNC-5001	E1-010773	Feb. 06, 2013	Feb. 05, 2014
Isolation Transformer (Erika Fiedler)	D-65396	017	Jul. 29, 2013	Jul. 28, 2014

- Notes: 1. The calibration interval of the above test instruments is 12 months and the calibrations are traceable to NML/ROC and NIST/USA.
 2. The test was performed in Shielded Room No. 10.
 3. The VCCI Site Registration No. C-1852

4.2.3 TEST PROCEDURES

- a. The EUT was placed 0.4 meters from the conducting wall of the shielded room with EUT being connected to the power mains through a line impedance stabilization network (LISN). Other support units were connected to the power mains through another LISN. The two LISNs provide 50 ohm/ 50uH of coupling impedance for the measuring instrument.
- b. Both lines of the power mains connected to the EUT were checked for maximum conducted interference.
- c. The frequency range from 150kHz to 30MHz was searched. Emission levels under (Limit - 20dB) was not recorded.

NOTE: All modes of operation were investigated and the worst-case emissions are reported.

4.2.4 DEVIATION FROM TEST STANDARD

No deviation.

4.2.5 TEST SETUP

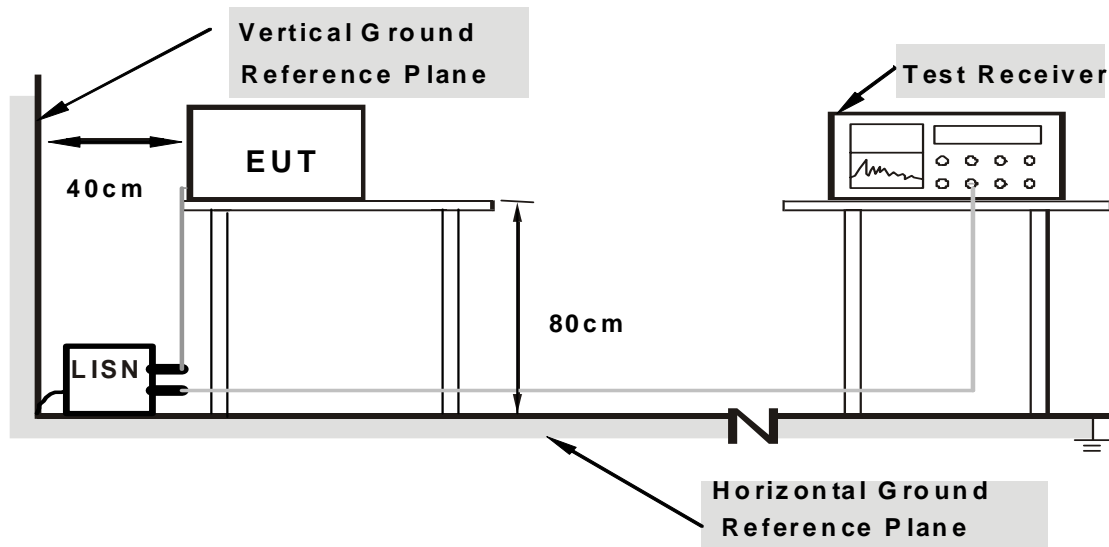

Note: Support units were connected to second LISN.

For the actual test configuration, please refer to the attached file (Test Setup Photo).

4.2.6 EUT OPERATING CONDITIONS

Same as 4.1.6.

4.2.7 TEST RESULTS

CONDUCTED WORST-CASE DATA : 802.11n (20MHz)

PHASE	Line 1	6dB BANDWIDTH	9kHz
-------	--------	---------------	------

No	Freq. [MHz]	Corr. Factor (dB)	Reading Value [dB (uV)]		Emission Level [dB (uV)]		Limit [dB (uV)]		Margin (dB)	
			Q.P.	AV.	Q.P.	AV.	Q.P.	AV.	Q.P.	AV.
1	0.15000	0.14	42.44	12.30	42.58	12.44	66.00	56.00	-23.42	-43.56
2	0.18906	0.15	38.13	25.67	38.28	25.82	64.08	54.08	-25.80	-28.26
3	0.25938	0.16	29.12	14.09	29.28	14.25	61.45	51.45	-32.18	-37.21
4	1.07813	0.16	31.20	17.27	31.36	17.43	56.00	46.00	-24.64	-28.57
5	2.57813	0.25	29.67	16.87	29.92	17.12	56.00	46.00	-26.08	-28.88
6	11.98438	0.87	38.63	28.59	39.50	29.46	60.00	50.00	-20.50	-20.54

REMARKS:

1. Q.P. and AV. are abbreviations of quasi-peak and average individually.
2. The emission levels of other frequencies were very low against the limit.
3. Margin value = Emission Level – Limit value
4. Correction Factor = Insertion loss + Cable loss
5. Emission Level = Correction Factor + Reading Value

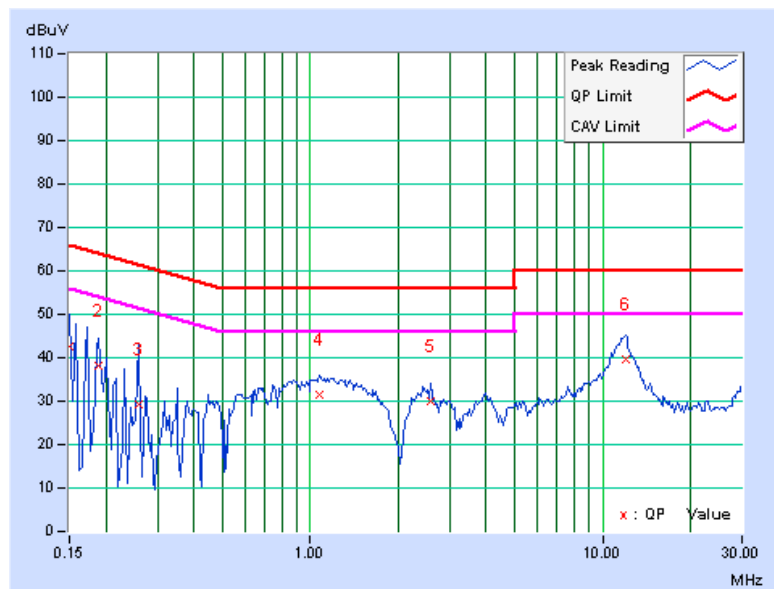



A D T

PHASE	Line 2	6dB BANDWIDTH	9kHz
-------	--------	---------------	------

No	Freq. [MHz]	Corr. Factor (dB)	Reading Value [dB (uV)]		Emission Level [dB (uV)]		Limit [dB (uV)]		Margin (dB)	
			Q.P.	AV.	Q.P.	AV.	Q.P.	AV.	Q.P.	AV.
			1	0.15391	0.53	27.36	4.43	27.89	4.96	65.79
2	0.19687	0.53	36.23	19.00	36.76	19.53	63.74	53.74	-26.98	-34.21
3	0.37444	0.54	25.39	11.92	25.93	12.46	58.40	48.40	-32.47	-35.94
4	0.87656	0.56	27.81	13.11	28.37	13.67	56.00	46.00	-27.63	-32.33
5	2.48438	0.57	26.49	14.62	27.06	15.19	56.00	46.00	-28.94	-30.81
6	11.32031	1.01	29.38	20.36	30.39	21.37	60.00	50.00	-29.61	-28.63

REMARKS:

1. Q.P. and AV. are abbreviations of quasi-peak and average individually.
2. The emission levels of other frequencies were very low against the limit.
3. Margin value = Emission Level – Limit value
4. Correction Factor = Insertion loss + Cable loss
5. Emission Level = Correction Factor + Reading Value

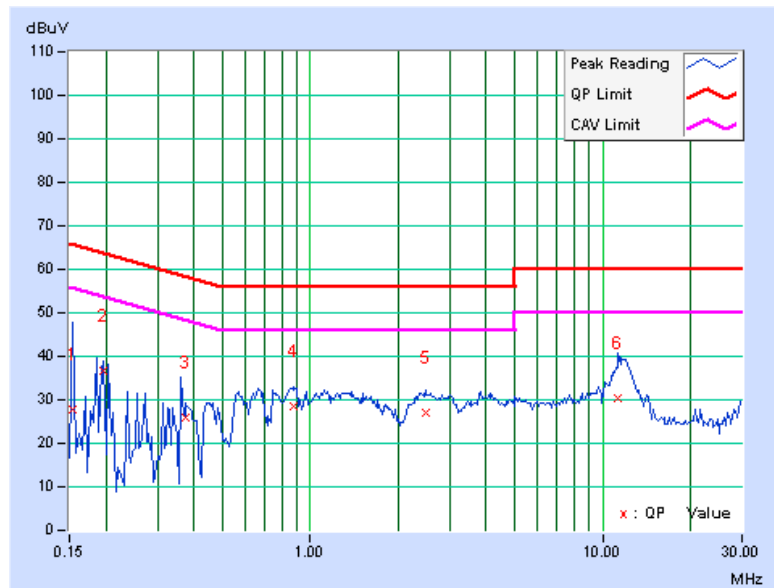

4.3 PEAK TRANSMIT POWER MEASUREMENT

4.3.1 LIMITS OF PEAK TRANSMIT POWER MEASUREMENT

FREQUENCY BAND	LIMIT
5.150 ~ 5.250GHz	The lesser of 50mW (17dBm) or 4dBm + 10logB
5.250 ~ 5.350GHz	The lesser of 250mW (24dBm) or 11dBm + 10logB

NOTE: Where B is the 26dB emission bandwidth in MHz.

Per KDB 662911 D01 Multiple Transmitter Output v02 Method of conducted output power measurement on IEEE 802.11 devices,

Array Gain = 0 dB (i.e., no array gain) for NANT \leq 4;

Array Gain = 0 dB (i.e., no array gain) for channel widths \geq 40 MHz for any NANT;

Array Gain = 5 log(NANT/NSS) dB or 3 dB, whichever is less for 20-MHz channel widths with NANT \geq 5.

For power measurements on all other devices: Array Gain = 10 log(NANT/NSS) dB.

4.3.2 TEST SETUP

FOR POWER OUTPUT MEASUREMENT

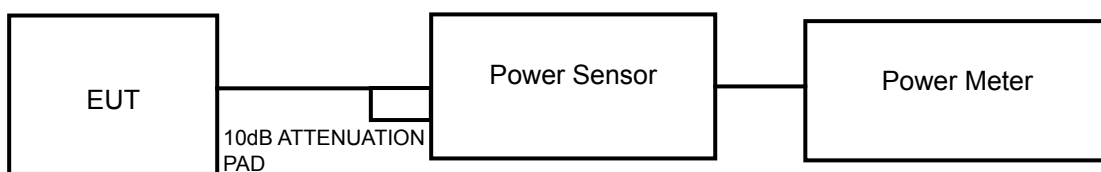

FOR 26dB BANDWIDTH

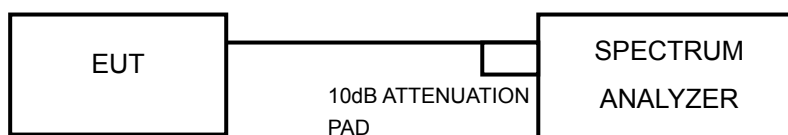

4.3.3 TEST INSTRUMENTS

Refer to section 4.1.3 to get information of above instrument.

4.3.4 TEST PROCEDURE

FOR AVERAGE POWER MEASUREMENT

Method PM is used to perform output power measurement, trigger and gating function of wide band power meter is enabled to measure max output power of TX on burst. Duty factor is not added to measured value.

FOR 26dB BANDWIDTH

- 1) Set RBW = approximately 1% of the emission bandwidth.
- 2) Set the VBW > RBW.
- 3) Detector = Peak.
- 4) Trace mode = max hold.
- 5) Measure the maximum width of the emission that is 26 dB down from the peak of the emission. Compare this with the RBW setting of the analyzer. Readjust RBW and repeat measurement as needed until the RBW/EBW ratio is approximately 1%.

4.3.5 DEVIATION FROM TEST STANDARD

No deviation.

4.3.6 EUT OPERATING CONDITIONS

The software provided by client to enable the EUT under transmission condition continuously at specific channel frequencies individually.

4.3.7 TEST RESULTS

POWER OUTPUT:

802.11a

CHAN.	CHAN. FREQ. (MHz)	AVERAGE POWER (dBm)	AVERAGE POWER (mW)	POWER LIMIT (dBm)	PASS / FAIL
36	5180	9.67	9.3	16.84	PASS
40	5200	9.25	8.4	16.84	PASS
48	5240	9.28	8.5	16.79	PASS
52	5260	9.23	8.4	23.80	PASS
60	5300	9.18	8.3	23.79	PASS
64	5320	9.09	8.1	23.81	PASS

1. $4\text{dBm} + 10\log(19.23) = 16.84 \text{ dBm} < 17\text{dBm}.$
2. $4\text{dBm} + 10\log(19.25) = 16.84 \text{ dBm} < 17\text{dBm}.$
3. $4\text{dBm} + 10\log(19.02) = 16.79 \text{ dBm} < 17\text{dBm}.$
4. $11\text{dBm} + 10\log(19.06) = 23.80 \text{ dBm} < 24\text{dBm}.$
5. $11\text{dBm} + 10\log(19.01) = 23.79 \text{ dBm} < 24\text{dBm}.$
6. $11\text{dBm} + 10\log(19.11) = 23.81 \text{ dBm} < 24\text{dBm}.$



802.11n (20MHz)

CHAN.	CHAN. FREQ. (MHz)	AVERAGE POWER (dBm)	AVERAGE POWER (mW)	POWER LIMIT (dBm)	PASS / FAIL
36	5180	9.09	8.1	16.91	PASS
40	5200	8.91	7.8	16.88	PASS
48	5240	8.81	7.6	16.89	PASS
52	5260	9.12	8.2	23.89	PASS
60	5300	8.78	7.6	23.89	PASS
64	5320	8.93	7.8	23.90	PASS

1. $4\text{dBm} + 10\log(19.54) = 16.91 \text{ dBm} < 17\text{dBm}$.
2. $4\text{dBm} + 10\log(19.42) = 16.88 \text{ dBm} < 17\text{dBm}$.
3. $4\text{dBm} + 10\log(19.46) = 16.89 \text{ dBm} < 17\text{dBm}$.
4. $11\text{dBm} + 10\log(19.45) = 23.89 \text{ dBm} < 24\text{dBm}$.
5. $11\text{dBm} + 10\log(19.47) = 23.89 \text{ dBm} < 24\text{dBm}$.
6. $11\text{dBm} + 10\log(19.48) = 23.90 \text{ dBm} < 24\text{dBm}$.



A D T

26dB BANDWIDTH:

CHANNEL	CHANNEL FREQUENCY (MHz)	26dBc BANDWIDTH (MHz)	PASS / FAIL
802.11a			
36	5180	19.23	PASS
40	5200	19.25	PASS
48	5240	19.02	PASS
52	5260	19.06	PASS
60	5300	19.01	PASS
64	5320	19.11	PASS
802.11n (20MHz)			
36	5180	19.54	PASS
40	5200	19.42	PASS
48	5240	19.46	PASS
52	5260	19.45	PASS
60	5300	19.47	PASS
64	5320	19.48	PASS

SPECTRUM PLOT OF WORST VALUE

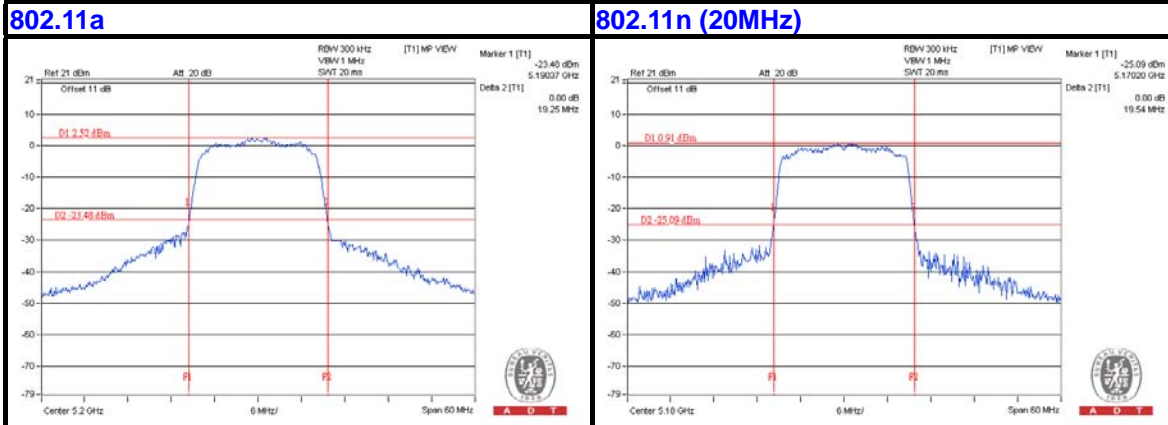

4.4 PEAK POWER SPECTRAL DENSITY MEASUREMENT

4.4.1 LIMITS OF PEAK POWER SPECTRAL DENSITY MEASUREMENT

FREQUENCY BAND	LIMIT
5.150 ~ 5.250GHz	4dBm
5.250 ~ 5.350GHz	11dBm

4.4.2 TEST SETUP

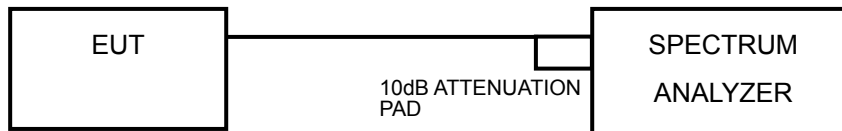

4.4.3 TEST INSTRUMENTS

Refer to section 4.1.3 to get information of above instrument.

4.4.4 TEST PROCEDURES

Using method SA-2

- 1) Set span to encompass the entire emission bandwidth (EBW) of the signal.
- 2) Set RBW = 30 KHz, Set VBW \geq 1 MHz, Detector = RMS
- 3) Set Channel power measure = 1MHz
- 4) Sweep time = auto, trigger set to "free run".
- 5) Trace average at least 100 traces in power averaging mode.
- 6) Record the max value and add $10 \log (1/\text{duty cycle})$

4.4.5 DEVIATION FROM TEST STANDARD

No deviation.

4.4.6 EUT OPERATING CONDITIONS

Same as 4.3.6.



A D T

4.4.7 TEST RESULTS

CHANNEL	FREQUENCY (MHz)	PSD W/O DUTY FACTOR (dBm)	DUTY FACTOR	PSD WITH DUTY FACTOR (dBm)	MAXIMUM LIMIT (dBm)	PASS/FAIL
802.11a						
36	5180	-2.42	0.62	-1.80	4	PASS
40	5200	-2.61	0.62	-1.99	4	PASS
48	5240	-3.37	0.62	-2.75	4	PASS
52	5260	-3.63	0.62	-3.01	11	PASS
60	5300	-3.95	0.62	-3.33	11	PASS
64	5320	-4.19	0.62	-3.57	11	PASS
802.11n (20MHz)						
36	5180	-2.96	0.67	-2.29	4	PASS
40	5200	-3.21	0.67	-2.54	4	PASS
48	5240	-3.70	0.67	-3.03	4	PASS
52	5260	-4.15	0.67	-3.48	11	PASS
60	5300	-4.57	0.67	-3.90	11	PASS
64	5320	-4.68	0.67	-4.01	11	PASS

NOTE:

1. Method a of power density measurement of KDB 662911 is using for calculating total power density. Total power density is summing entire spectra across corresponding frequency bins on the various outputs by computer.
2. Refer to section 3.3 for duty cycle spectrum plot.

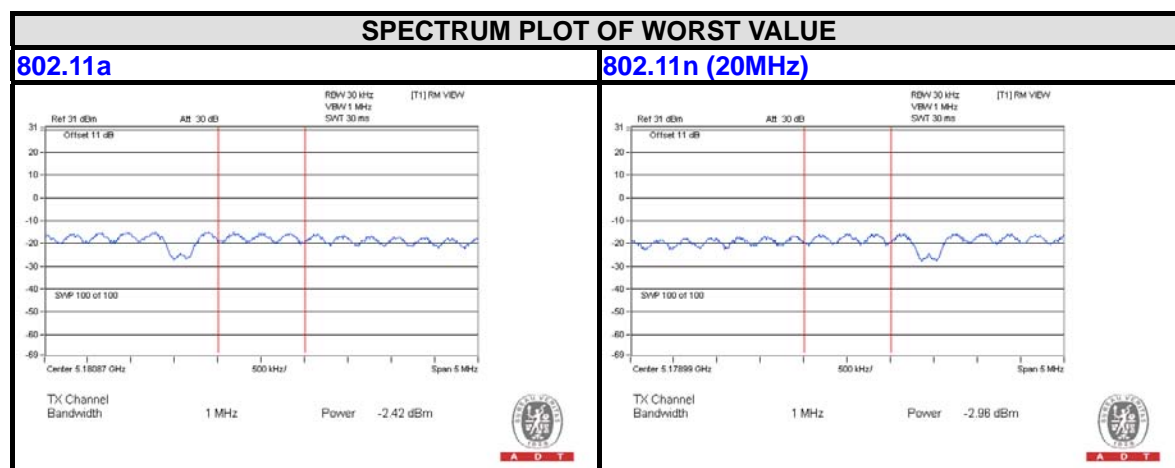

4.5 PEAK POWER EXCURSION MEASUREMENT

4.5.1 LIMITS OF PEAK POWER EXCURSION MEASUREMENT

Shall not exceed 13 dB.

4.5.2 TEST SETUP

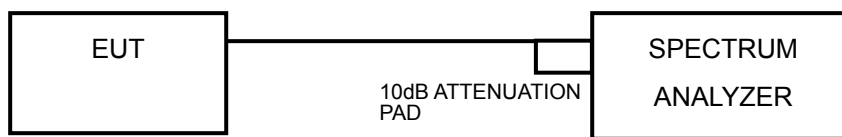

4.5.3 TEST INSTRUMENTS

Refer to section 4.1.3 to get information of above instrument.

4.5.4 TEST PROCEDURE

- 1) Set RBW = 1 MHz, VBW \geq 3 MHz, Detector = peak.
- 2) Trace mode = max-hold. Allow the sweeps to continue until the trace stabilizes.
- 3) Use the peak search function to find the peak of the spectrum.
- 4) Measure the PPSD.
- 5) Compute the ratio of the maximum of the peak-max-hold spectrum to the PPSD.
Find the worst channel and modulation mode as above test procedure, and follow KDB 789033 D01 General UNII Test Procedures v01r03 and repeat step 1 to 5 for final testing of each modulation mode on a single channel (all modulation types) in a single operating band to compliance with the peak excursion requirement.

4.5.5 DEVIATION FROM TEST STANDARD

No deviation.

4.5.6 EUT OPERATING CONDITIONS

Same as 4.2.6

4.5.7 TEST RESULTS

MODULATION MODE	MODULATION TYPE	CHAN. FREQ. (MHz)	PEAK VALUE (dBm)	PPSD WITHOUT DUTY FACTOR (dBm)	PPSD WITH DUTY FACTOR (dBm)	PEAK EXCURSION (dB)	LIMIT (dB)	PASS /FAIL
802.11a	BPSK	5180	8.41	-2.42	-1.80	10.21	13	PASS
	QPSK		8.22	-2.69	-2.56	10.78	13	PASS
	16QAM		8.73	-2.97	-2.72	11.45	13	PASS
	64QAM		7.80	-3.65	-3.17	10.97	13	PASS
802.11n (20MHz)	BPSK	5180	6.86	-2.96	-2.29	9.15	13	PASS
	QPSK		7.37	-3.29	-3.09	10.46	13	PASS
	16QAM		7.73	-3.59	-3.21	10.94	13	PASS
	64QAM		7.52	-3.68	-3.15	10.67	13	PASS

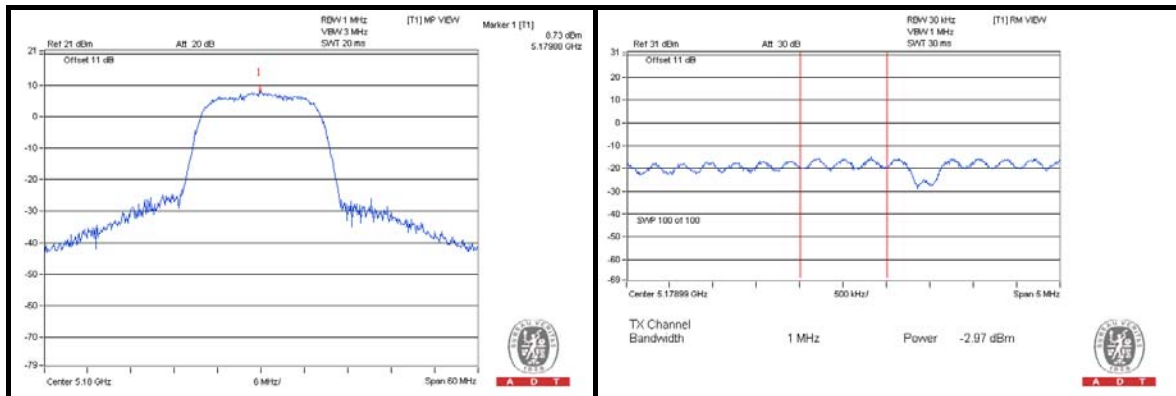

4.6 FREQUENCY STABILITY

4.6.1 LIMITS OF FREQUENCY STABILITY MEASUREMENT

The frequency of the carrier signal shall be maintained within band of operation

4.6.2 TEST SETUP

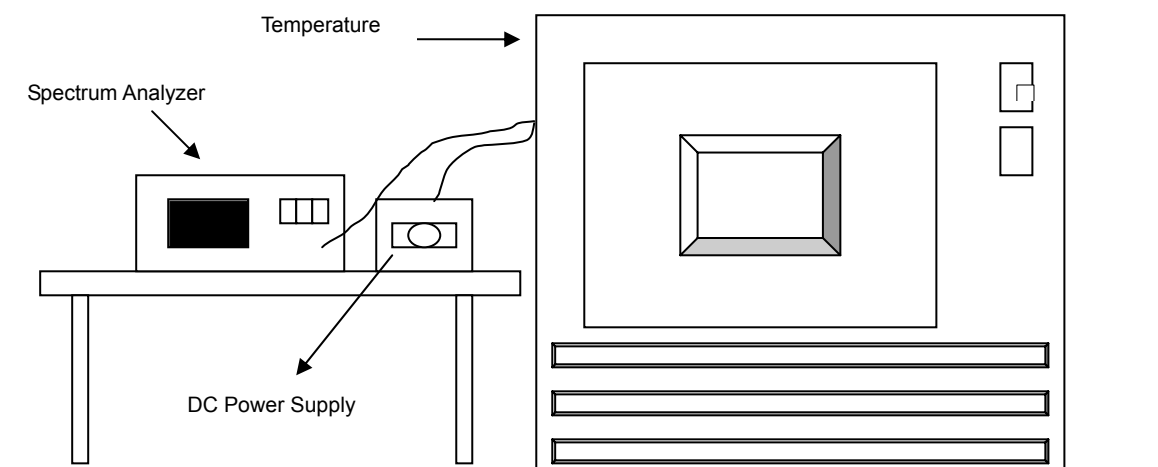

4.6.3 TEST INSTRUMENTS

Refer to section 4.1.3 to get information of above instrument.

4.6.4 TEST PROCEDURE

- a. The EUT was placed inside the environmental test chamber and powered by nominal DC voltage.
- b. Turn the EUT on and couple its output to a spectrum analyzer.
- c. Turn the EUT off and set the chamber to the highest temperature specified.
- d. Allow sufficient time (approximately 30 min) for the temperature of the chamber to stabilize, turn the EUT on and measure the operating frequency after 2, 5, and 10 minutes.
- e. Repeat step b and c with the temperature chamber set to the lowest temperature.
- f. The test chamber was allowed to stabilize at +20 degree C for a minimum of 30 minutes. The supply voltage was then adjusted on the EUT from 85% to 115% and the frequency record.

4.6.5 DEVIATION FROM TEST STANDARD

No deviation.

4.6.6 EUT OPERATING CONDITION

Set the EUT transmit at un-modulation mode to test frequency stability.

4.6.7 TEST RESULTS

FREQUENCY STABILITY VERSUS TEMP.									
OPERATING FREQUENCY: 5180MHz									
TEMP. (°C)	POWER SUPPLY (Vac)	0 MINUTE		2 MINUTE		5 MINUTE		10 MINUTE	
		Measured Frequency (MHz)	Frequency Drift (ppm)	Measured Frequency (MHz)	Frequency Drift (ppm)	Measured Frequency (MHz)	Frequency Drift (ppm)	Measured Frequency (MHz)	Frequency Drift (ppm)
50	120.0	5180.043082	8.3170137	5180.042879	8.2777747	5180.042772	8.2571899	5180.043119	8.3241959
40	120.0	5180.042763	8.2553384	5180.042743	8.2515804	5180.042635	8.2306703	5180.042885	8.2790119
30	120.0	5180.042997	8.3006514	5180.043046	8.3100286	5180.042920	8.2856570	5180.042748	8.2524736
20	120.0	5180.043115	8.3233501	5180.042592	8.2224183	5180.042935	8.2885472	5180.042744	8.2517581
10	120.0	5180.042869	8.2758806	5180.042979	8.2970085	5180.042947	8.2909368	5180.042655	8.2345138
0	120.0	5180.042837	8.2697591	5180.042708	8.2446943	5180.042704	8.2439584	5180.042737	8.2503973
-10	120.0	5180.043100	8.3204937	5180.042973	8.2960338	5180.042766	8.2560287	5180.043037	8.3082128
-20	120.0	5180.043006	8.3022893	5180.043375	8.3735148	5180.043044	8.3095621	5180.043092	8.3189677

FREQUENCY STABILITY VERSUS VOLTAGE									
OPERATING FREQUENCY: 5180MHz									
TEMP. (°C)	POWER SUPPLY (Vac)	0 MINUTE		2 MINUTE		5 MINUTE		10 MINUTE	
		Measured Frequency (MHz)	Frequency Drift (ppm)	Measured Frequency (MHz)	Frequency Drift (ppm)	Measured Frequency (MHz)	Frequency Drift (ppm)	Measured Frequency (MHz)	Frequency Drift (ppm)
20	138.0	5180.042646	8.2328560	5180.042839	8.2699949	5180.043071	8.3148063	5180.042966	8.2945443
	120.0	5180.043115	8.3233501	5180.042592	8.2224183	5180.042935	8.2885472	5180.042744	8.2517581
	102.0	5180.042559	8.2160201	5180.042734	8.2497978	5180.042881	8.2782078	5180.042639	8.2314128

5. PHOTOGRAPHS OF THE TEST CONFIGURATION

Please refer to the attached file (Test Setup Photo).



6. INFORMATION ON THE TESTING LABORATORIES

We, Bureau Veritas Consumer Products Services (H.K.) Ltd., Taoyuan Branch, were founded in 1988 to provide our best service in EMC, Radio, Telecom and Safety consultation. Our laboratories are accredited and approved according to ISO/IEC 17025.

If you have any comments, please feel free to contact us at the following:

Linko EMC/RF Lab:
Tel: 886-2-26052180
Fax: 886-2-26051924

Hsin Chu EMC/RF Lab:
Tel: 886-3-5935343
Fax: 886-3-5935342

Hwa Ya EMC/RF/Safety Telecom Lab:
Tel: 886-3-3183232
Fax: 886-3-3270892

Email: service.adt@tw.bureauveritas.com
Web Site: www.bureauveritas-adt.com

The address and road map of all our labs can be found in our web site also.

7. APPENDIX A – MODIFICATIONS RECORDERS FOR ENGINEERING CHANGES TO THE EUT BY THE LAB

No modifications were made to the EUT by the lab during the test.

---END---