



# FCC TEST REPORT (RFID)

**REPORT NO.:** RF131126D16A-4  
**MODEL NO.:** TR10Cxy  
**FCC ID:** WL6-TRBC1CD1  
**RECEIVED:** Dec. 18, 2013  
**TESTED:** Dec. 7, 2013 ~ Jan. 10, 2014  
**ISSUED:** Jan. 17, 2014

**APPLICANT:** Elitegroup Computer Systems Co., Ltd

**ADDRESS:** No. 239, Ti Ding Blvd., Sec. 2, Taipei, Taiwan  
11493

**ISSUED BY:** Bureau Veritas Consumer Products Services  
(H.K.) Ltd., Taoyuan Branch

**LAB ADDRESS:** No. 47, 14th Ling, Chia Pau Vil., Lin Kou Dist.,  
New Taipei City, Taiwan, R.O.C.

This report should not be used by the client to claim product certification, approval, or endorsement by TAF or any government agencies.



This report is for your exclusive use. Any copying or replication of this report to or for any other person or entity, or use of our name or trademark, is permitted only with our prior written permission. This report sets forth our findings solely with respect to the test samples identified herein. The results set forth in this report are not indicative or representative of the quality or characteristics of the lot from which a test sample was taken or any similar or identical product unless specifically and expressly noted. Our report includes all of the tests requested by you and the results thereof based upon the information that you provided to us. You have 60 days from date of issuance of this report to notify us of any material error or omission caused by our negligence, provided, however, that such notice shall be in writing and shall specifically address the issue you wish to raise. A failure to raise such issue within the prescribed time shall constitute your unqualified acceptance of the completeness of this report, the tests conducted and the correctness of the report contents. Unless specific mention, the uncertainty of measurement has been explicitly taken into account to declare the compliance or non-compliance to the specification.



## Table of Contents

RELEASE CONTROL RECORD .....	3
1. CERTIFICATION.....	4
2. SUMMARY OF TEST RESULTS .....	5
2.1 MEASUREMENT UNCERTAINTY .....	5
3. GENERAL INFORMATION .....	6
3.1 GENERAL DESCRIPTION OF EUT .....	6
3.2 DESCRIPTION OF TEST MODES .....	7
3.2.1 TEST MODE APPLICABILITY AND TESTED CHANNEL DETAIL.....	7
3.3 DESCRIPTION OF SUPPORT UNITS .....	8
3.3.1 CONFIGURATION OF SYSTEM UNDER TEST.....	8
3.4 GENERAL DESCRIPTION OF APPLIED STANDARDS.....	9
4. TEST TYPES AND RESULTS .....	10
4.1 RADIATED EMISSION MEASUREMENT.....	10
4.1.1 LIMITS OF RADIATED EMISSION MEASUREMENT .....	10
4.1.2 TEST INSTRUMENTS.....	11
4.1.3 TEST PROCEDURES .....	12
4.1.4 DEVIATION FROM TEST STANDARD.....	12
4.1.5 TEST SETUP.....	13
4.1.6 EUT OPERATING CONDITIONS .....	13
4.1.7 TEST RESULTS .....	14
4.2 CONDUCTED EMISSION MEASUREMENT.....	18
4.2.1 LIMITS OF CONDUCTED EMISSION MEASUREMENT .....	18
4.2.2 TEST INSTRUMENTS.....	18
4.2.3 TEST PROCEDURES .....	19
4.2.4 DEVIATION FROM TEST STANDARD.....	19
4.2.5 TEST SETUP.....	19
4.2.6 EUT OPERATING CONDITIONS .....	19
4.2.7 TEST RESULTS .....	20
4.3 FREQUENCY STABILITY.....	22
4.3.1 LIMITS OF FREQUENCY STABILITY MEASUREMENT.....	22
4.3.2 TEST INSTRUMENTS.....	22
4.3.3 TEST PROCEDURE.....	22
4.3.4 DEVIATION FROM TEST STANDARD.....	23
4.3.5 TEST SETUP.....	23
4.3.6 EUT OPERATING CONDITION.....	23
4.3.7 TEST RESULTS .....	24
5. PHOTOGRAPHS OF THE TEST CONFIGURATION .....	25
6. INFORMATION ON THE TESTING LABORATORIES.....	26
7. APPENDIX A - MODIFICATIONS RECORDERS FOR ENGINEERING CHANGES TO THE EUT BY THE LAB.....	27



## RELEASE CONTROL RECORD

ISSUE NO.	REASON FOR CHANGE	DATE ISSUED
RF131126D16A-4	Original release	Jan. 17, 2014



# 1. CERTIFICATION

**PRODUCT:** Wireless Motherboard  
**BRAND NAME:** ECS ELITEGROUP  
**MODEL:** TR10Cxy (x=0~9, A~Z or blank or "-";y=0~9, A~Z or blank or "-")  
**APPLICANT:** Elitegroup Computer Systems Co., Ltd  
**TESTED:** Dec. 7, 2013 ~ Jan. 10, 2014  
**TEST SAMPLE:** ENGINEERING SAMPLE  
**STANDARDS:** **FCC Part 15, Subpart C (Section 15.225)**  
ANSI C63.10-2009

The above equipment (Model: TR10CD1) has been tested by **Bureau Veritas Consumer Products Services (H.K.) Ltd., Taoyuan Branch**, and found compliance with the requirement of the above standards. The test record, data evaluation & Equipment Under Test (EUT) configurations represented herein are true and accurate accounts of the measurements of the sample's EMC characteristics under the conditions specified in this report.

**PREPARED BY :** Annie Chang , **DATE:** Jan. 17, 2014  
( Annie Chang / Supervisor )

**APPROVED BY :** Rex Lai , **DATE:** Jan. 17, 2014  
( Rex Lai / Assistant Manager )



## 2. SUMMARY OF TEST RESULTS

The EUT has been tested according to the following specifications:

APPLIED STANDARD: FCC PART 15, SUBPART C (SECTION 15.225, 15.215)			
STANDARD SECTION	TEST TYPE AND LIMIT	RESULT	REMARK
15.207	Conducted emission test	PASS	Meet the requirement of limit. Minimum passing margin is -21.01dB at 0.17344MHz.
15.225 (a)	The field strength of any emissions within the band 13.553-13.567 MHz	PASS	Meet the requirement of limit. Minimum passing margin is -71.6dB at 13.56MHz.
15.225 (d)	The field strength of any emissions appearing outside of the 13.110-14.010 MHz band	PASS	Meet the requirement of limit. Minimum passing margin is -7.9dB at 42.13MHz.
15.225 (e)	The frequency tolerance	PASS	Meet the requirement of limit.

### 2.1 MEASUREMENT UNCERTAINTY

Where relevant, the following measurement uncertainty levels have been estimated for tests performed on the EUT as specified in CISPR 16-4-2:

MEASUREMENT	FREQUENCY	UNCERTAINTY
Conducted Emission	150kHz ~ 30MHz	2.41 dB
Radiated emissions	30MHz ~ 200MHz	4.30 dB
	200MHz ~1000MHz	3.36 dB

This uncertainty represents an expanded uncertainty expressed at approximately the 95% confidence level using a coverage factor of k=2.

### 3. GENERAL INFORMATION

#### 3.1 GENERAL DESCRIPTION OF EUT

<b>EUT</b>	Wireless Motherboard
<b>MODEL NO.</b>	TR10Cxy
<b>POWER SUPPLY</b>	5Vdc from AC adapter or 3.7V from Battery
<b>MODULATION TYPE</b>	ASK
<b>OPERATING FREQUENCY</b>	13.56MHz
<b>ANTENNA TYPE</b>	FPC Antenna
<b>DATA CABLE</b>	N/A
<b>I/O PORTS</b>	Refer to user's manual
<b>ACCESSORY DEVICES</b>	Refer to Note as below

**NOTE:**

1. The EUT is a Wireless Motherboard with a NFC module (Brand: NXP, Model: PN650).
2. The "x & y" in the model could be defined as 0~9, A~Z or blank for marketing differentiation. During the test, model: **TR10CD1** was selected as the representative one and therefore only its test data was recorded in this report.
3. The EUT consumes power from an AC adapter or battery, as follows:

Item	Brand	Model No.	Spec.
Adapter	Hunkey	HKA01005020-3H	AC I/P: 1100-240V, 0.5A, 50/60Hz DC O/P: 5V, 2A AC 2 Pin. Non-shielded DC cable (1.5m)
Battery 1	Sunwoda	LI8100	3.7Vdc, 8100mAh
Battery 2	Sunwoda	LI6300	3.7Vdc, 6300mAh

After pre-tested, the worst emission level was found when the EUT was tested under **Adapter with Battery 1** mode, therefore, only its test data was recorded in this report.

4. For Radiated Emissions test, following modes were pre-tested:
  - ◆ EUT + Adapter
  - ◆ EUT only

The worst emission level was found when the EUT was tested under **EUT + Adapter** mode, therefore, only its test data was recorded in this report.
5. The above EUT information is declared by the manufacturer and for more detailed features description, please refer to the manufacturer's specifications or User's Manual.

## 3.2 DESCRIPTION OF TEST MODES

### 3.2.1 TEST MODE APPLICABILITY AND TESTED CHANNEL DETAIL

EUT CONFIGURE MODE	APPLICABLE TO			DESCRIPTION
	RE	PLC	FS	
-	√	√	√	-

Where RE: Radiated Emission      PLC: Power Line Conducted Emission  
FS: Frequency Stability

**NOTE:** The EUT had been pre-tested on the positioned of 3 axis. The worst case was found when positioned on X-plane.

#### RADIATED EMISSION TEST:

- Pre-Scan has been conducted to determine the worst-case mode from all possible combinations between available modulations antenna ports (if EUT with antenna diversity architecture).
- Following channel(s) was (were) selected for the final test as listed below.

AVAILABLE CHANNEL	TESTED CHANNEL	MODULATION TYPE
1	1	ASK

#### POWER LINE CONDUCTED EMISSION TEST:

- Pre-Scan has been conducted to determine the worst-case mode from all possible combinations between available modulations and antenna ports (if EUT with antenna diversity architecture).
- Following channel(s) was (were) selected for the final test as listed below.

AVAILABLE CHANNEL	TESTED CHANNEL	MODULATION TYPE
1	1	ASK

#### FREQUENCY STABILITY:

- Pre-Scan has been conducted to determine the worst-case mode from all possible combinations between available modulations and antenna ports (if EUT with antenna diversity architecture).
- Following channel(s) was (were) selected for the final test as listed below.

AVAILABLE CHANNEL	TESTED CHANNEL	MODULATION TYPE
1	1	ASK

#### TEST CONDITION:

APPLICABLE TO	ENVIRONMENTAL CONDITIONS	INPUT POWER	TESTED BY
RE	23deg. C, 74% RH	120Vac, 60Hz	Joey Liu
PLC	23deg. C, 75% RH	120Vac, 60Hz	Joey Liu
FS	24deg. C, 70%RH	120Vac, 60Hz	Dalen Dai

### 3.3 DESCRIPTION OF SUPPORT UNITS

The EUT has been tested as an independent unit together with other necessary accessories or support units. The following support units or accessories were used to form a representative test configuration during the tests.

NO.	PRODUCT	BRAND	MODEL NO.	SERIAL NO.	FCC ID
1	NOTEBOOK COMPUTER	DELL	510m	1KZ1G1S	FCC DoC Approved

NO.	SIGNAL CABLE DESCRIPTION OF THE ABOVE SUPPORT UNITS
1	0.4m shielded USB cable

**NOTE:** All power cords of the above support units are non shielded (1.8m).

#### 3.3.1 CONFIGURATION OF SYSTEM UNDER TEST

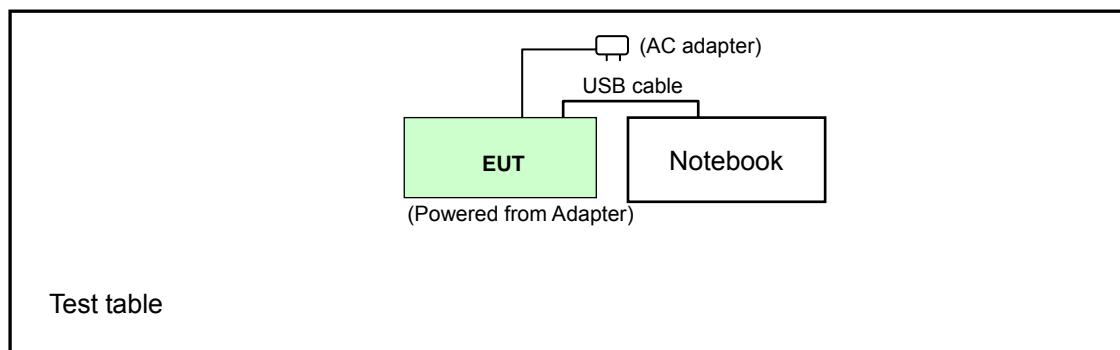



### **3.4 GENERAL DESCRIPTION OF APPLIED STANDARDS**

The EUT is a RFID Product. According to the specifications of the manufacturer, it must comply with the requirements of the following standards:

**FCC Part 15, Subpart C (15.225)**

**ANSI C63.10-2009**

All test items have been performed and recorded as per the above standards.

## 4. TEST TYPES AND RESULTS

### 4.1 RADIATED EMISSION MEASUREMENT

#### 4.1.1 LIMITS OF RADIATED EMISSION MEASUREMENT

The field strength of any emissions within the band 13.553-13.567 MHz shall not exceed 15,848 microvolts/meter at 30 meters.

The field strength of any emissions appearing outside of the 13.110-14.010 MHz band shall not exceed the general radiated emission limits in § 15.209.

FREQUENCIES (MHz)	FIELD STRENGTH (microvolts/meter)	MEASUREMENT DISTANCE (meters)
0.009 ~ 0.490	2400/F(kHz)	300
0.490 ~ 1.705	24000/F(kHz)	30
1.705 ~ 30.0	30	30
30 ~ 88	100	3
88 ~ 216	150	3
216 ~ 960	200	3
Above 960	500	3

**NOTE:**

1. The lower limit shall apply at the transition frequencies.
2. Emission level (dBuV/m) = 20 log Emission level (uV/m).
3. As shown in 15.35(b), for frequencies above 1000MHz, the field strength limits are based on average detector, however, the peak field strength of any emission shall not exceed the maximum permitted average limits, specified above by more than 20dB under any condition of modulation.

#### 4.1.2 TEST INSTRUMENTS

DESCRIPTION & MANUFACTURER	MODEL NO.	SERIAL NO.	CALIBRATED DATE	CALIBRATED UNTIL
HP Preamplifier	8447D	2432A03504	Feb. 26, 2013	Feb. 25, 2014
HP Preamplifier	8449B	3008A01201	Feb. 26, 2013	Feb. 25, 2014
Agilent TEST RECEIVER	N9038A	MY51210129	Jan. 03, 2013	Jan. 02, 2014
Schwarzbeck Antenna	VULB 9168	137	Mar. 20, 2013	Mar. 19, 2014
Schwarzbeck Antenna	VHBA 9123	480	May 29, 2013	May 28, 2014
ADT. Turn Table	TT100	0306	NA	NA
ADT. Tower	AT100	0306	NA	NA
Software	ADT_Radiated_V 7.6.15.9.2	NA	NA	NA
SUHNER RF cable	SF102	CABLE-CH6	Aug. 19, 2013	Aug. 18, 2014
Schwarzbeck Horn Antenna	BBHA 9120-D1	D130	May 13, 2013	May 12, 2014
Highpass filter Wainwright Instruments	WHK 3.1/18G-10SS	SN 8	NA	NA
ROHDE & SCHWARZ Spectrum Analyzer	FSP 40	100036	May. 17, 2013	May. 16, 2014
Anritsu Power Sensor	MA2411B	0738404	Apr. 24, 2013	Apr. 23, 2014
Anritsu Power Meter	ML2495A	0842014	Apr. 25, 2013	Apr. 24, 2014
Schwarzbeck Horn Antenna	BBHA 9120-D1	D130	May 13, 2013	May 12, 2014

- NOTE:** 1. The calibration interval of the above test instruments is 12/24 months. And the calibrations are traceable to NML/ROC and NIST/USA.  
 2. The horn antenna and HP preamplifier (model: 8449B) are used only for the measurement of emission frequency above 1GHz if tested.  
 3. The test was performed in Chamber No. 6.  
 4. The Industry Canada Reference No. IC 7450E-6.  
 5. The FCC Site Registration No. is 447212.

### 4.1.3 TEST PROCEDURES

- a. The EUT was placed on the top of a rotating table 0.8 meters above the ground at a 3 meter semi-anechoic chamber. The table was rotated 360 degrees to determine the position of the highest radiation.
- b. The EUT was set 3 meters away from the interference-receiving antenna, which was mounted on the top of a variable-height antenna tower.
- c. The height of antenna is varied from one meter to four meters above the ground to determine the maximum value of the field strength. Both horizontal and vertical polarizations of the antenna are set to make the measurement.
- d. For each suspected emission, the EUT was arranged to its worst case and then the antenna was tuned to heights from 1 meter to 4 meters and the rotatable table was turned from 0 degrees to 360 degrees to find the maximum reading.
- e. The test-receiver system was set to Peak Detect Function and Specified Bandwidth with Maximum Hold Mode.
- f. If the emission level of the EUT in peak mode was lower than the limit specified, then testing could be stopped and the peak values of the EUT would be reported. Otherwise the emissions would be re-tested one by one using peak, quasi-peak or average method as specified and then reported in a data sheet.

### 4.1.4 DEVIATION FROM TEST STANDARD

No deviation.

#### 4.1.5 TEST SETUP

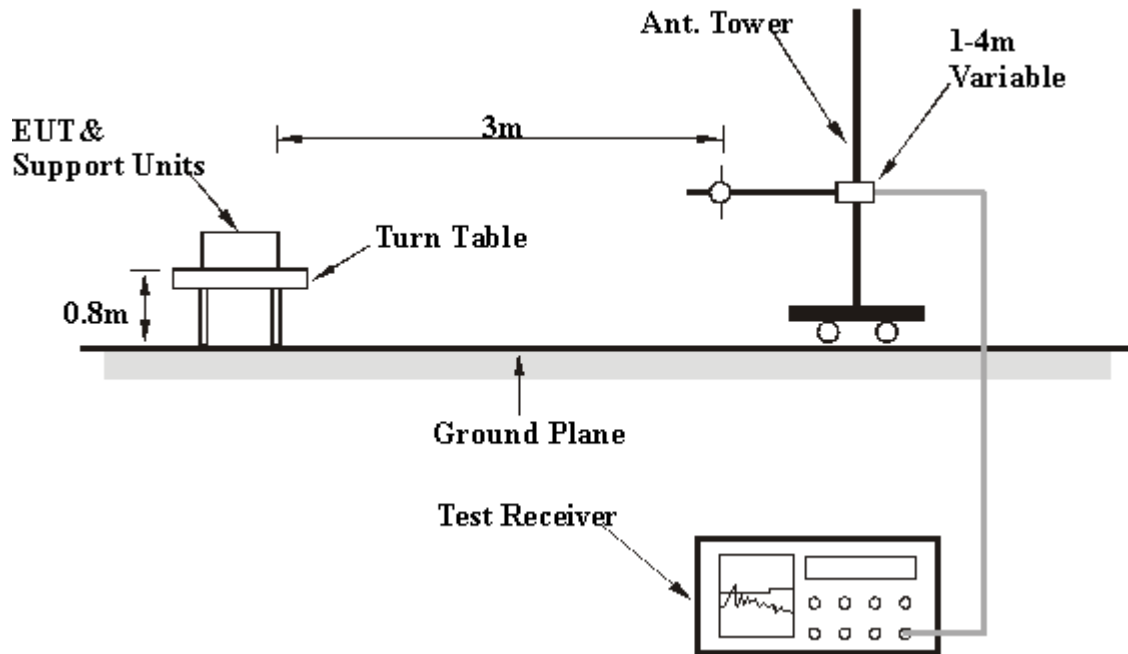

For the actual test configuration, please refer to the attached file (Test Setup Photo).

#### 4.1.6 EUT OPERATING CONDITIONS

- a. Connected the EUT to AC adapter.
- b. The Notebook connected with EUT via a USBH cable and run a test program (provided by manufacturer) to enable EUT under transmission condition continuously at specific channel frequency.

### 4.1.7 TEST RESULTS

<b>CHANNEL</b>	TX Channel 1	<b>DETECTOR FUNCTION</b>	Quasi-Peak
<b>FREQUENCY RANGE</b>	13.56MHz		

ANTENNA POLARITY & TEST DISTANCE: LOOP ANTENNA OPEN AT 3m								
No.	Freq. (MHz)	Emission Level (dBuV/m)	Limit (dBuV/m)	Margin (dB)	Antenna Height (m)	Table Angle (Degree)	Raw Value (dBuV)	Correction Factor (dB/m)
1	13.56	52.4	124.0	-71.6	1.0	300	30.63	21.74

**REMARKS:**

1. Emission Level(dBuV/m) = Raw Value(dBuV) + Correction Factor(dB/m)
2. Correction Factor(dB/m) = Antenna Factor(dB/m) + Cable Factor(dB) – Pre-Amplifier Factor(dB)
3. The other emission levels were very low against the limit.
4. Margin value = Emission Level – Limit value
5. Above limits have been translated by the formula

The measured field strength was extrapolated to distance 30 meters, using the formula that the limit of field strength varies as the inverse distance square (40dB per decade of distance)

Example:

$$\begin{aligned}
 13.56\text{MHz} &= 15848\mu\text{V/m} && 30\text{m} \\
 &= 84\text{dBuV/m} && 30\text{m} \\
 &= 84+20\log(30/3)^2 && 3\text{m} \\
 &= 124\text{dBuV/m}
 \end{aligned}$$

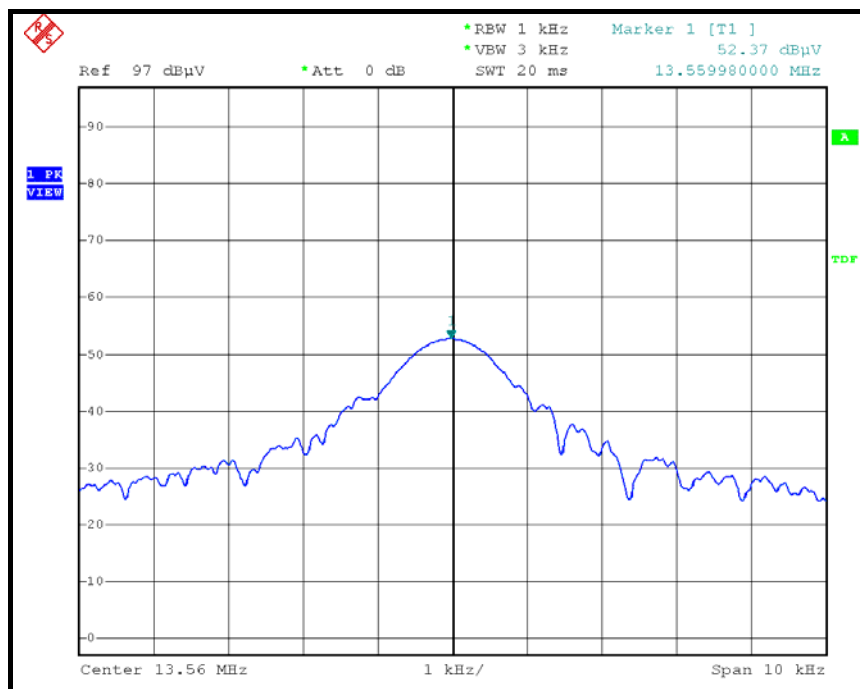

<b>CHANNEL</b>	TX Channel 1	<b>DETECTOR FUNCTION</b>	Quasi-Peak
<b>FREQUENCY RANGE</b>	13.56MHz		

ANTENNA POLARITY & TEST DISTANCE: LOOP ANTENNA CLOSE AT 3m								
No.	Freq. (MHz)	Emission Level (dBuV/m)	Limit (dBuV/m)	Margin (dB)	Antenna Height (m)	Table Angle (Degree)	Raw Value (dBuV)	Correction Factor (dB/m)
1	13.56	52.0	124.0	-72.0	1.0	319	30.27	21.74

**REMARKS:**

1. Emission Level(dBuV/m) = Raw Value(dBuV) + Correction Factor(dB/m)
2. Correction Factor(dB/m) = Antenna Factor(dB/m) + Cable Factor(dB) – Pre-Amplifier Factor(dB)
3. The other emission levels were very low against the limit.
4. Margin value = Emission Level – Limit value
5. Above limits have been translated by the formula

The measured field strength was extrapolated to distance 30 meters, using the formula that the limit of field strength varies as the inverse distance square (40dB per decade of distance)

Example:

$$\begin{aligned}
 13.56\text{MHz} &= 15848\mu\text{V/m} && 30\text{m} \\
 &= 84\text{dBuV/m} && 30\text{m} \\
 &= 84+20\log(30/3)^2 && 3\text{m} \\
 &= 124\text{dBuV/m}
 \end{aligned}$$

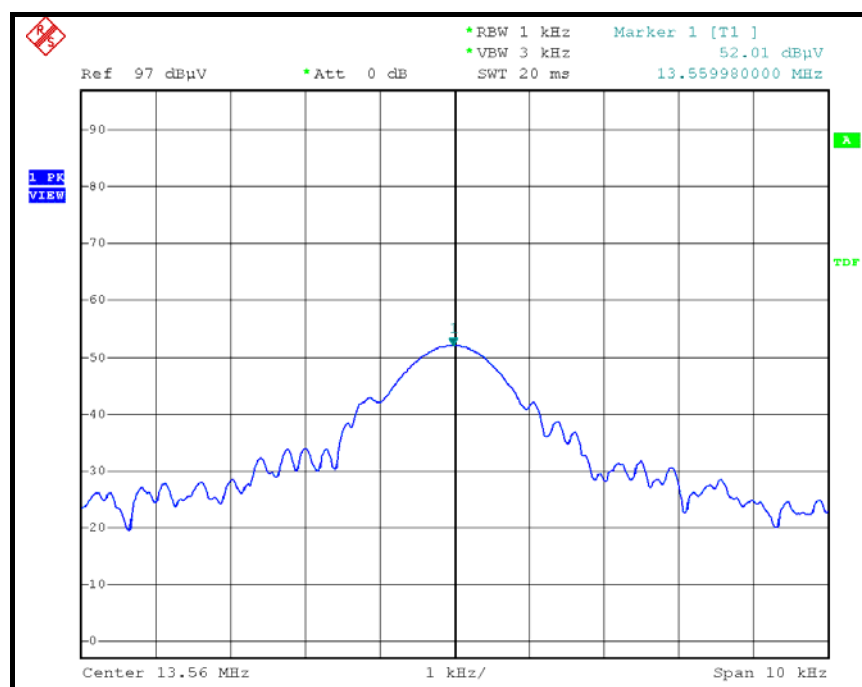

<b>CHANNEL</b>	TX Channel 1	<b>DETECTOR FUNCTION</b>	Quasi-Peak
<b>FREQUENCY RANGE</b>	9kHz – 30MHz		

ANTENNA POLARITY & TEST DISTANCE: LOOP ANTENNA OPEN AT 3m								
No.	Freq. (MHz)	Emission Level (dBuV/m)	Limit (dBuV/m)	Margin (dB)	Antenna Height (m)	Table Angle (Degree)	Raw Value (dBuV)	Correction Factor (dB/m)
1	27.12	39.5 QP	69.5	-30.0	1.00	297	16.28	23.25
ANTENNA POLARITY & TEST DISTANCE: LOOP ANTENNA CLOSE AT 3m								
No.	Freq. (MHz)	Emission Level (dBuV/m)	Limit (dBuV/m)	Margin (dB)	Antenna Height (m)	Table Angle (Degree)	Raw Value (dBuV)	Correction Factor (dB/m)
1	27.12	38.4 QP	69.5	-31.1	1.00	335	15.17	23.25

**REMARKS:**

1. Emission Level(dBuV/m) = Raw Value(dBuV) + Correction Factor(dB/m)
2. Correction Factor(dB/m) = Antenna Factor(dB/m) + Cable Factor(dB) – Pre-Amplifier Factor(dB)
3. The other emission levels were very low against the limit.
4. Margin value = Emission Level – Limit value



<b>CHANNEL</b>	TX Channel 1	<b>DETECTOR FUNCTION</b>	Quasi-Peak
<b>FREQUENCY RANGE</b>	30-1000MHz		

ANTENNA POLARITY & TEST DISTANCE: HORIZONTAL AT 3 M								
NO.	FREQ. (MHz)	EMISSION LEVEL (dBuV/m)	LIMIT (dBuV/m)	MARGIN (dB)	ANTENNA HEIGHT (m)	TABLE ANGLE (Degree)	RAW VALUE (dBuV)	CORRECTION FACTOR (dB/m)
1	81.54	31.8 QP	40.0	-8.2	1.45 H	34	50.02	-18.24
2	112.24	31.1 QP	43.5	-12.4	1.33 H	255	47.60	-16.52
3	199.76	34.4 QP	43.5	-9.2	1.32 H	89	50.28	-15.93
4	240.00	33.0 QP	46.0	-13.0	1.68 H	111	47.09	-14.06
5	306.97	30.5 QP	46.0	-15.5	1.35 H	211	41.83	-11.29
6	381.11	28.8 QP	46.0	-17.2	1.68 H	3	38.60	-9.81

ANTENNA POLARITY & TEST DISTANCE: VERTICAL AT 3 M								
NO.	FREQ. (MHz)	EMISSION LEVEL (dBuV/m)	LIMIT (dBuV/m)	MARGIN (dB)	ANTENNA HEIGHT (m)	TABLE ANGLE (Degree)	RAW VALUE (dBuV)	CORRECTION FACTOR (dB/m)
1	42.13	32.1 QP	40.0	-7.9	1.67 V	135	46.34	-14.27
2	83.17	31.3 QP	40.0	-8.7	1.78 V	155	50.15	-18.84
3	166.33	35.3 QP	43.5	-8.2	1.47 V	319	48.81	-13.55
4	197.89	30.8 QP	43.5	-12.7	1.65 V	333	46.61	-15.83
5	423.27	31.1 QP	46.0	-14.9	1.69 V	135	40.16	-9.07
6	527.54	29.0 QP	46.0	-17.0	1.55 V	133	35.87	-6.91

**REMARKS:**

1. Emission Level(dBuV/m) = Raw Value(dBuV) + Correction Factor(dB/m)
2. Correction Factor(dB/m) = Antenna Factor(dB/m) + Cable Factor(dB) – Pre-Amplifier Factor(dB)
3. The other emission levels were very low against the limit.
4. Margin value = Emission Level – Limit value

## 4.2 CONDUCTED EMISSION MEASUREMENT

### 4.2.1 LIMITS OF CONDUCTED EMISSION MEASUREMENT

FREQUENCY OF EMISSION (MHz)	CONDUCTED LIMIT (dB $\mu$ V)	
	Quasi-peak	Average
0.15 ~ 0.5	66 to 56	56 to 46
0.5 ~ 5	56	46
5 ~ 30	60	50

- NOTE:**
1. The lower limit shall apply at the transition frequencies.
  2. The limit decreases in line with the logarithm of the frequency in the range of 0.15 to 0.50 MHz.

### 4.2.2 TEST INSTRUMENTS

Description & Manufacturer	Model No.	Serial No.	Cal. Date	Cal. Due
ROHDE & SCHWARZ TEST RECEIVER	ESCS 30	100276	Jan. 07, 2014	Jan. 06, 2015
ROHDE & SCHWARZ Artificial Mains Network (for EUT)	ESH3-Z5	100219	Nov. 17, 2013	Nov. 16, 2014
LISN With Adapter (for EUT)	AD10	C10Ada-001	Nov. 17, 2013	Nov. 16, 2014
ROHDE & SCHWARZ Artificial Mains Network (for peripherals)	ESH3-Z5	100218	Nov. 25, 2013	Nov. 24, 2014
Software	ADT_Cond_V7.3.7	NA	NA	NA
Software	ADT_ISN_V7.3.7	NA	NA	NA
RF cable (JYEBAO)	5D-FB	Cable-C10.01	Feb. 19, 2013	Feb. 18, 2014
SUHNER Terminator (For ROHDE & SCHWARZ LISN)	65BNC-5001	E1-010773	Feb. 06, 2013	Feb. 05, 2014
Isolation Transformer (Erika Fiedler)	D-65396	017	Jul. 29, 2013	Jul. 28, 2014

- Notes:
1. The calibration interval of the above test instruments is 12 months and the calibrations are traceable to NML/ROC and NIST/USA.
  2. The test was performed in Shielded Room No. 10.
  3. The VCCI Site Registration No. C-1852

### 4.2.3 TEST PROCEDURES

- The EUT was placed 0.4 meters from the conducting wall of the shielded room with EUT being connected to the power mains through a line impedance stabilization network (LISN). Other support units were connected to the power mains through another LISN. The two LISNs provide 50 ohm/ 50uH of coupling impedance for the measuring instrument.
- Both lines of the power mains connected to the EUT were checked for maximum conducted interference.
- The frequency range from 150kHz to 30MHz was searched. Emission levels under (Limit - 20dB) was not recorded.

**NOTE:** All modes of operation were investigated and the worst-case emissions are reported.

### 4.2.4 DEVIATION FROM TEST STANDARD

No deviation.

### 4.2.5 TEST SETUP

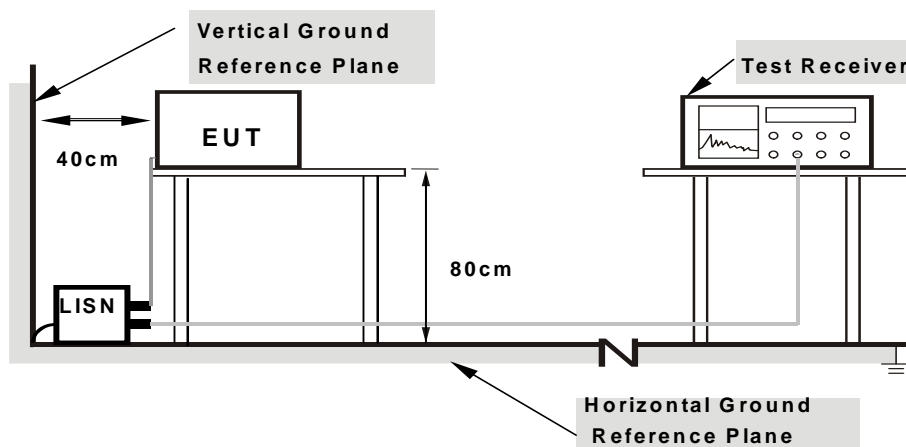

- Note:**
- Support units were connected to second LISN.
  - Both of LISNs (AMN) are 80 cm from EUT and at least 80 cm from other units and other metal planes

For the actual test configuration, please refer to the attached file (Test Setup Photo).

### 4.2.6 EUT OPERATING CONDITIONS

Same as 4.1.6.

## 4.2.7 TEST RESULTS

PHASE	Line 1	6dB BANDWIDTH	9kHz
-------	--------	---------------	------

No	Freq. [MHz]	Corr. Factor (dB)	Reading Value [dB (uV)]		Emission Level [dB (uV)]		Limit [dB (uV)]		Margin (dB)	
			Q.P.	AV.	Q.P.	AV.	Q.P.	AV.	Q.P.	AV.
1	0.15781	0.14	32.06	9.51	32.20	9.65	65.58	55.58	-33.38	-45.93
2	0.18906	0.15	37.84	27.66	37.99	27.81	64.08	54.08	-26.09	-26.27
3	0.57188	0.17	21.74	6.92	21.91	7.09	56.00	46.00	-34.09	-38.91
4	1.18359	0.17	29.66	17.50	29.83	17.67	56.00	46.00	-26.17	-28.33
5	2.50391	0.25	23.80	14.89	24.05	15.14	56.00	46.00	-31.95	-30.86
6	13.56000	0.96	32.52	24.19	33.48	25.15	60.00	50.00	-26.52	-24.85

### REMARKS:

1. Q.P. and AV. are abbreviations of quasi-peak and average individually.
2. The emission levels of other frequencies were very low against the limit.
3. Margin value = Emission Level – Limit value
4. Correction Factor = Insertion loss + Cable loss
5. Emission Level = Correction Factor + Reading Value

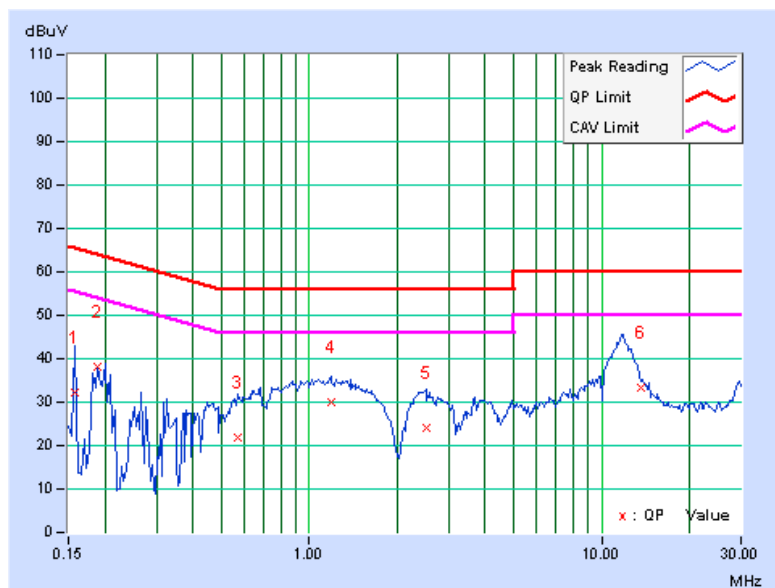

PHASE	Line 2	6dB BANDWIDTH	9kHz
-------	--------	---------------	------

No	Freq. [MHz]	Corr. Factor (dB)	Reading Value [dB (uV)]		Emission Level [dB (uV)]		Limit [dB (uV)]		Margin (dB)	
			Q.P.	AV.	Q.P.	AV.	Q.P.	AV.	Q.P.	AV.
1	0.17344	0.53	43.25	23.38	43.78	23.91	64.79	54.79	-21.01	-30.88
2	0.25156	0.53	29.75	12.19	30.28	12.72	61.71	51.71	-31.42	-38.98
3	0.67344	0.55	28.53	13.49	29.08	14.04	56.00	46.00	-26.92	-31.96
4	1.10547	0.56	26.10	12.87	26.66	13.43	56.00	46.00	-29.34	-32.57
5	2.41406	0.58	27.14	14.79	27.72	15.37	56.00	46.00	-28.28	-30.63
6	13.56000	1.09	26.53	15.39	27.62	16.48	60.00	50.00	-32.38	-33.52

**REMARKS:**

1. Q.P. and AV. are abbreviations of quasi-peak and average individually.
2. The emission levels of other frequencies were very low against the limit.
3. Margin value = Emission Level – Limit value
4. Correction Factor = Insertion loss + Cable loss
5. Emission Level = Correction Factor + Reading Value

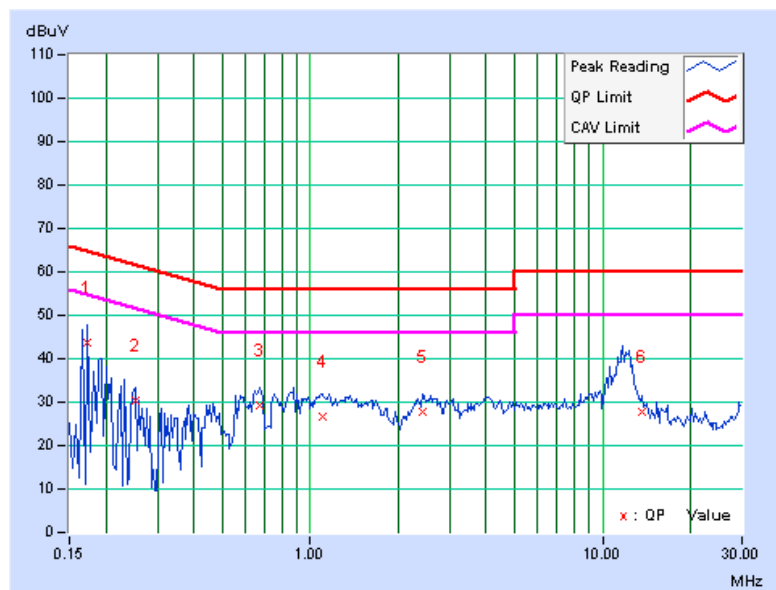

### 4.3 FREQUENCY STABILITY

#### 4.3.1 LIMITS OF FREQUENCY STABILITY MEASUREMENT

The frequency tolerance of the carrier signal shall be maintained within +/- 0.01% of the operating frequency over a temperature variation of -20 degrees to 50 degrees C at normal supply voltage, and for a variation in the primary supply voltage from 85% to 115% of the rated supply voltage at a temperature of 20 degrees C.

#### 4.3.2 TEST INSTRUMENTS

DESCRIPTION & MANUFACTURER	MODEL NO.	SERIAL NO.	DATE OF CALIBRATION	DUE DATE OF CALIBRATION
R&S SPECTRUM ANALYZER	FSP 40	100036	May. 17, 2013	May. 16, 2014
Temperature & Humidity Chamber	MHU-225AU	920409	May 23, 2013	May 22, 2014

**NOTE:** The calibration interval of the above test instruments is 12 months and the calibrations are traceable to NML/ROC and NIST/USA.

#### 4.3.3 TEST PROCEDURE

- a. The EUT was placed inside the environmental test chamber and powered by nominal DC voltage.
- b. Turn the EUT on and couple its output to a spectrum analyzer.
- c. Turn the EUT off and set the chamber to the highest temperature specified.
- d. Allow sufficient time (approximately 30 min) for the temperature of the chamber to stabilize, turn the EUT on and measure the operating frequency after 2, 5, and 10 minutes.
- e. Repeat step b and c with the temperature chamber set to the lowest temperature.
- f. The test chamber was allowed to stabilize at +20 degree C for a minimum of 30 minutes. The supply voltage was then adjusted on the EUT from 85% to 115% and the frequency record.

#### 4.3.4 DEVIATION FROM TEST STANDARD

No deviation.

#### 4.3.5 TEST SETUP

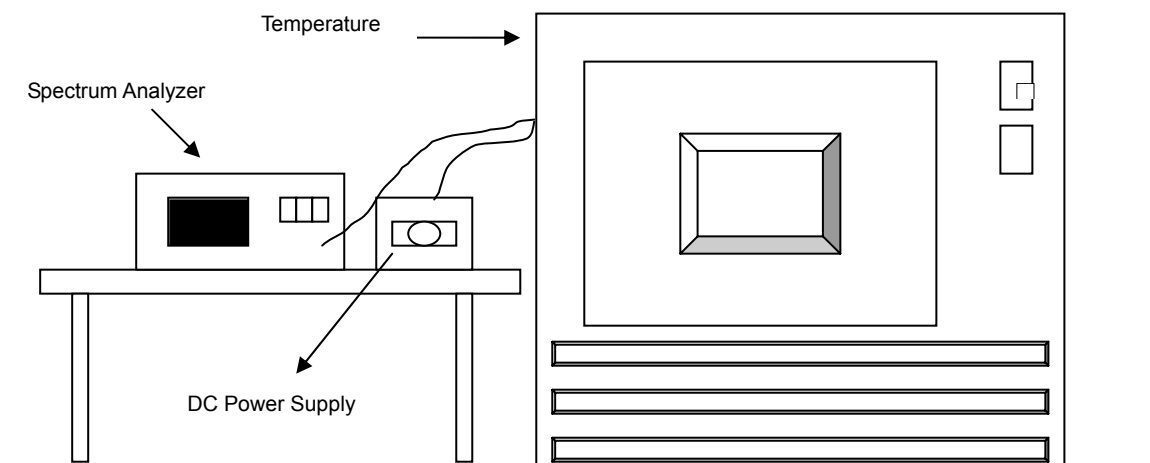

#### 4.3.6 EUT OPERATING CONDITION

Same as Item 4.1.6.

### 4.3.7 TEST RESULTS

OPERATING FREQUENCY: 13.56MHz		LIMIT: $\pm 0.01\%$	
TEMP. (°C)	POWER SUPPLY (Vac)	(MHz)	(%)
20	120	13.5605	0
	138	13.5607	0.00147
	102	13.5602	-0.00074
-20	120	13.5610	0.00368
55	120	13.5598	-0.00368

**Note:** Operating temperature of EUT is -20 degrees C to 55 degrees C.



## 5. PHOTOGRAPHS OF THE TEST CONFIGURATION

Please refer to the attached file (Test Setup Photo).



## 6. INFORMATION ON THE TESTING LABORATORIES

We, Bureau Veritas Consumer Products Services (H.K.) Ltd., Taoyuan Branch, were founded in 1988 to provide our best service in EMC, Radio, Telecom and Safety consultation. Our laboratories are accredited and approved according to ISO/IEC 17025.

If you have any comments, please feel free to contact us at the following:

**Linko EMC/RF Lab:**

Tel: 886-2-26052180

Fax: 886-2-26051924

**Hsin Chu EMC/RF Lab:**

Tel: 886-3-5935343

Fax: 886-3-5935342

**Hwa Ya EMC/RF/Safety Telecom Lab:**

Tel: 886-3-3183232

Fax: 886-3-3270892

**Email:** [service.adt@tw.bureauveritas.com](mailto:service.adt@tw.bureauveritas.com)

**Web Site:** [www.bureauveritas-adt.com](http://www.bureauveritas-adt.com)

The address and road map of all our labs can be found in our web site also.

## 7. APPENDIX A - MODIFICATIONS RECORDERS FOR ENGINEERING CHANGES TO THE EUT BY THE LAB

No modifications were made to the EUT by the lab during the test.

--- END ---