



A D T

# FCC TEST REPORT (WLAN)

**REPORT NO.:** RF130610D25  
**MODEL NO.:** TM75A, TM75wxyz  
**FCC ID:** WL6-TMBC0002  
**RECEIVED:** Jun. 10, 2013  
**TESTED:** Jun. 17 ~ 19, 2013  
**ISSUED:** Jun. 27, 2013

**APPLICANT:** Elitegroup Computer Systems Co., Ltd

**ADDRESS:** No. 239, Sec. 2, Ti Ding Blvd., Taipei, Taiwan  
11493

**ISSUED BY:** Bureau Veritas Consumer Products Services  
(H.K.) Ltd., Taoyuan Branch

**LAB ADDRESS:** No. 47, 14th Ling, Chia Pau Vil., Lin Kou Dist.,  
New Taipei City, Taiwan, R.O.C.

This report should not be used by the client to claim product certification, approval, or endorsement by TAF or any government agencies.



This report is for your exclusive use. Any copying or replication of this report to or for any other person or entity, or use of our name or trademark, is permitted only with our prior written permission. This report sets forth our findings solely with respect to the test samples identified herein. The results set forth in this report are not indicative or representative of the quality or characteristics of the lot from which a test sample was taken or any similar or identical product unless specifically and expressly noted. Our report includes all of the tests requested by you and the results thereof based upon the information that you provided to us. You have 60 days from date of issuance of this report to notify us of any material error or omission caused by our negligence, provided, however, that such notice shall be in writing and shall specifically address the issue you wish to raise. A failure to raise such issue within the prescribed time shall constitute your unqualified acceptance of the completeness of this report, the tests conducted and the correctness of the report contents. Unless specific mention, the uncertainty of measurement has been explicitly taken into account to declare the compliance or non-compliance to the specification.



## TABLE OF CONTENTS

RELEASE CONTROL RECORD.....	4
1. CERTIFICATION.....	5
2. SUMMARY OF TEST RESULTS.....	6
2.1 MEASUREMENT UNCERTAINTY.....	6
3. GENERAL INFORMATION.....	7
3.1 GENERAL DESCRIPTION OF EUT.....	7
3.2 DESCRIPTION OF TEST MODES.....	9
3.2.1 TEST MODE APPLICABILITY AND TESTED CHANNEL DETAIL.....	10
3.3 DESCRIPTION OF SUPPORT UNITS.....	12
3.3.1 CONFIGURATION OF SYSTEM UNDER TEST.....	12
3.4 GENERAL DESCRIPTION OF APPLIED STANDARDS.....	13
4. TEST TYPES AND RESULTS.....	14
4.1 RADIATED EMISSION AND BANDEDGE MEASUREMENT.....	14
4.1.1 LIMITS OF RADIATED EMISSION AND BANDEDGE MEASUREMENT.....	14
4.1.2 TEST INSTRUMENTS.....	15
4.1.3 TEST PROCEDURES.....	16
4.1.4 DEVIATION FROM TEST STANDARD.....	16
4.1.5 TEST SETUP.....	17
4.1.6 EUT OPERATING CONDITIONS.....	17
4.1.7 TEST RESULTS.....	18
4.2 CONDUCTED EMISSION MEASUREMENT.....	28
4.2.1 LIMITS OF CONDUCTED EMISSION MEASUREMENT.....	28
4.2.2 TEST INSTRUMENTS.....	28
4.2.3 TEST PROCEDURES.....	29
4.2.4 DEVIATION FROM TEST STANDARD.....	29
4.2.5 TEST SETUP.....	30
4.2.6 EUT OPERATING CONDITIONS.....	30
4.2.7 TEST RESULTS.....	31
4.3 6dB BANDWIDTH MEASUREMENT.....	33
4.3.1 LIMITS OF 6dB BANDWIDTH MEASUREMENT.....	33
4.3.2 TEST SETUP.....	33
4.3.3 TEST INSTRUMENTS.....	33
4.3.4 TEST PROCEDURE.....	33
4.3.5 DEVIATION FROM TEST STANDARD.....	33
4.3.6 EUT OPERATING CONDITIONS.....	33
4.3.7 TEST RESULTS.....	34
4.4 CONDUCTED OUTPUT POWER.....	35
4.4.1 LIMITS OF CONDUCTED OUTPUT POWER MEASUREMENT.....	35
4.4.2 TEST SETUP.....	35



4.4.3	TEST INSTRUMENTS .....	35
4.4.4	TEST PROCEDURES.....	35
4.4.5	DEVIATION FROM TEST STANDARD .....	35
4.4.6	EUT OPERATING CONDITIONS.....	35
4.4.7	TEST RESULTS.....	36
4.5	POWER SPECTRAL DENSITY MEASUREMENT.....	38
4.5.1	LIMITS OF POWER SPECTRAL DENSITY MEASUREMENT .....	38
4.5.2	TEST SETUP .....	38
4.5.3	TEST INSTRUMENTS .....	38
4.5.4	TEST PROCEDURE .....	38
4.5.5	DEVIATION FROM TEST STANDARD .....	38
4.5.6	EUT OPERATING CONDITION .....	38
4.5.7	TEST RESULTS.....	39
4.6	CONDUCTED OUT OF BAND EMISSION MEASUREMENT .....	40
4.6.1	LIMITS OF CONDUCTED OUT OF BAND EMISSION MEASUREMENT ....	40
4.6.2	TEST SETUP .....	40
4.6.3	TEST INSTRUMENTS .....	40
4.6.4	TEST PROCEDURE .....	40
4.6.5	DEVIATION FROM TEST STANDARD .....	41
4.6.6	EUT OPERATING CONDITION .....	41
4.6.7	TEST RESULTS.....	41
5.	PHOTOGRAPHS OF THE TEST CONFIGURATION.....	45
6.	INFORMATION ON THE TESTING LABORATORIES .....	46
7.	APPENDIX A - MODIFICATIONS RECORDERS FOR ENGINEERING CHANGES TO THE EUT BY THE LAB .....	47



A D T

## RELEASE CONTROL RECORD

ISSUE NO.	REASON FOR CHANGE	DATE ISSUED
RF130610D25	Original release	Jun. 27, 2013



A D T

## 1. CERTIFICATION

**PRODUCT:** 7" table PC

**BRAND NAME:** ECS

**MODEL NO.:** TM75A, TM75wxyz  
(w=0-9,a-z or blank, "-";  
x=0-9,a-z or blank, "-";  
y=0-9,a-z or blank, "-";  
z=0-9,a-z or blank, "-")

**APPLICANT:** Elitegroup Computer Systems Co., Ltd

**TESTED:** Jun. 17 ~ 19, 2013

**TEST SAMPLE:** ENGINEERING SAMPLE

**STANDARDS:** FCC Part 15, Subpart C (Section 15.247)

ANSI C63.10-2009

The above equipment (model no.: TM75A) has been tested by **Bureau Veritas Consumer Products Services (H.K.) Ltd., Taoyuan Branch**, and found compliance with the requirement of the above standards. The test record, data evaluation & Equipment Under Test (EUT) configurations represented herein are true and accurate accounts of the measurements of the sample's EMC characteristics under the conditions specified in this report.

**PREPARED BY** : Celia Chen , **DATE:** Jun. 27, 2013  
( Celia Chen / Senior Specialist )

**APPROVED BY** : Ken Liu , **DATE:** Jun. 27, 2013  
( Ken Liu / Senior Manager )



A D T

## 2. SUMMARY OF TEST RESULTS

The EUT has been tested according to the following specifications:

APPLIED STANDARD: FCC PART 15, SUBPART C (SECTION 15.247)			
STANDARD SECTION	TEST TYPE	RESULT	REMARK
15.207	AC Power Conducted Emission	PASS	Meet the requirement of limit. Minimum passing margin is -10.22dB at 2.38672MHz.
15.247(d) 15.209	Radiated Emissions	PASS	Meet the requirement of limit. Minimum passing margin is -0.5dB at 4924.00MHz.
15.247(d)	Band Edge Measurement	PASS	Meet the requirement of limit.
15.247(a)(2)	6dB bandwidth	PASS	Meet the requirement of limit.
15.247(b)	Conducted power	PASS	Meet the requirement of limit.
15.247(e)	Power Spectral Density	PASS	Meet the requirement of limit.
15.203	Antenna Requirement	PASS	Antenna connector is IPEX not a standard connector.

### 2.1 MEASUREMENT UNCERTAINTY

Where relevant, the following measurement uncertainty levels have been estimated for tests performed on the EUT as specified in CISPR 16-4-2:

MEASUREMENT	FREQUENCY	UNCERTAINTY
Conducted emissions	150kHz~30MHz	2.41 dB
Radiated emissions	30MHz ~ 1GHz	4.30 dB
	Above 1GHz	3.36 dB

This uncertainty represents an expanded uncertainty expressed at approximately the 95% confidence level using a coverage factor of  $k = 2$ .



### 3. GENERAL INFORMATION

#### 3.1 GENERAL DESCRIPTION OF EUT

<b>EUT</b>	7" table PC
<b>MODEL NO.</b>	TM75A, TM75wxyz
<b>POWER SUPPLY</b>	5Vdc from power adapter 3.7Vdc from battery
<b>MODULATION TYPE</b>	CCK, DQPSK, DBPSK for DSSS 64QAM, 16QAM, QPSK, BPSK for OFDM
<b>MODULATION TECHNOLOGY</b>	DSSS, OFDM
<b>TRANSFER RATE</b>	802.11b:11.0/ 5.5/ 2.0/ 1.0Mbps 802.11g: 54.0/ 48.0/ 36.0/ 24.0/ 18.0/ 12.0/ 9.0/ 6.0Mbps 802.11n: up to 72.0Mbps
<b>OPERATING FREQUENCY</b>	2412 ~ 2462MHz
<b>NUMBER OF CHANNEL</b>	11 for 802.11b, 802.11g, 802.11n (20MHz)
<b>OUTPUT POWER</b>	207.0mW
<b>ANTENNA TYPE</b>	PIFA antenna with -2.78dBi gain
<b>ANTENNA CONNECTOR</b>	IPEX connector
<b>DATA CABLE</b>	Non-shielded USB cable (1m)
<b>I/O PORTS</b>	Refer to user's manual
<b>ACCESSORY DEVICES</b>	Refer to note below

**Note:**

1. The EUT incorporates a SISO function. Physically, the EUT provides one completed transmitter and one receiver.

<b>MODULATION MODE</b>	<b>TX FUNCTION</b>
<b>802.11b</b>	1TX
<b>802.11g</b>	1TX
<b>802.11n (20MHz)</b>	1TX
<b>802.11n (40MHz)</b>	1TX



2. The following models are provided to this EUT.

Model No.	Description
TM75A	All models are electrically identical, different model names are for marketing purpose.
TM75wxyz	
(w=0-9,a-z or blank, "-"; x=0-9,a-z or blank, "-"; y=0-9,a-z or blank, "-"; z=0-9,a-z or blank, "-")	

From the above models, **model: TM75A** was selected as representative model for the test and its test data was recorded in this report.

3. The EUT equipped the following accessory:

Item	Brand	Model	Spec.
Power Adapter	SHENZHEN FRECOME ELECTRONICS CO., LTD.	F12W-050200SPAU	AC I/P: 100-240V, 50/60Hz, 0.3A DC O/P: 5V, 2A AC 2-Pin Non-shielded DC cable (1.5m)

4. The EUT was pre-tested with the following modes:

- 2 EUT + Adapter
- 2 EUT + Battery
- 2 EUT link to PC via USB cable

The worst emission level was found when the EUT tested under **EUT + Adapter**, therefore, only its test data was recorded in this report.

5. The above EUT information was declared by manufacturer and for more detailed features description, please refer to the manufacturer's specifications or User's Manual.





### 3.2 DESCRIPTION OF TEST MODES

11 channels are provided for 802.11b, 802.11g and 802.11n (20MHz):

CHANNEL	FREQUENCY	CHANNEL	FREQUENCY
1	2412MHz	7	2442MHz
2	2417MHz	8	2447MHz
3	2422MHz	9	2452MHz
4	2427MHz	10	2457MHz
5	2432MHz	11	2462MHz
6	2437MHz		



### 3.2.1 TEST MODE APPLICABILITY AND TESTED CHANNEL DETAIL

EUT CONFIGURE MODE	APPLICABLE TO					DESCRIPTION
	RE <sup>3</sup> 1G	RE<1G	PLC	APCM	OB	
-	√	√	√	√	√	EUT + Adapter

Where **RE<sup>3</sup>1G**: Radiated Emission above 1GHz      **RE<1G**: Radiated Emission below 1GHz  
**PLC**: Power Line Conducted Emission      **APCM**: Antenna Port Conducted Measurement  
**OB**: Conducted Out-Band Emission Measurement

**NOTE:** The EUT had been pre-tested on the positioned of each 3 axis. The worst case was found when positioned on **X-plane**.

#### RADIATED EMISSION TEST (ABOVE 1GHz):

- Pre-Scan has been conducted to determine the worst-case mode from all possible combinations between available modulations, data rates and antenna ports (if EUT with antenna diversity architecture).
- Following channel(s) was (were) selected for the final test as listed below.

EUT CONFIGURE MODE	MODE	AVAILABLE CHANNEL	TESTED CHANNEL	MODULATION TECHNOLOGY	MODULATION TYPE	DATA RATE (Mbps)
-	802.11b	1 to 11	1, 6, 11	DSSS	DBPSK	1.0
-	802.11g	1 to 11	1, 6, 11	OFDM	BPSK	6.0
-	802.11n (20MHz)	1 to 11	1, 6, 11	OFDM	BPSK	6.5

#### RADIATED EMISSION TEST (BELOW 1GHz):

- Pre-Scan has been conducted to determine the worst-case mode from all possible combinations between available modulations, data rates and antenna ports (if EUT with antenna diversity architecture).
- Following channel(s) was (were) selected for the final test as listed below.

EUT CONFIGURE MODE	MODE	AVAILABLE CHANNEL	TESTED CHANNEL	MODULATION TECHNOLOGY	MODULATION TYPE	DATA RATE (Mbps)
-	802.11g	1 to 11	11	OFDM	BPSK	6.0

#### POWER LINE CONDUCTED EMISSION TEST:

- Pre-Scan has been conducted to determine the worst-case mode from all possible combinations between available modulations, data rates and antenna ports (if EUT with antenna diversity architecture).
- Following channel(s) was (were) selected for the final test as listed below.

EUT CONFIGURE MODE	MODE	AVAILABLE CHANNEL	TESTED CHANNEL	MODULATION TECHNOLOGY	MODULATION TYPE	DATA RATE (Mbps)
-	802.11g	1 to 11	11	OFDM	BPSK	6.0



A D T

#### **ANTENNA PORT CONDUCTED MEASUREMENT:**

- This item includes all test value of each mode, but only includes spectrum plot of worst value of each mode.
- Pre-Scan has been conducted to determine the worst-case mode from all possible combinations between available modulations, data rates and antenna ports (if EUT with antenna diversity architecture).
- Following channel(s) was (were) selected for the final test as listed below.

EUT CONFIGURE MODE	MODE	AVAILABLE CHANNEL	TESTED CHANNEL	MODULATION TECHNOLOGY	MODULATION TYPE	DATA RATE (Mbps)
-	802.11b	1 to 11	1, 6, 11	DSSS	DBPSK	1.0
-	802.11g	1 to 11	1, 6, 11	OFDM	BPSK	6.0
-	802.11n (20MHz)	1 to 11	1, 6, 11	OFDM	BPSK	6.5

#### **CONDUCTED OUT-BAND EMISSION MEASUREMENT:**

- Pre-Scan has been conducted to determine the worst-case mode from all possible combinations between available modulations, data rates and antenna ports (if EUT with antenna diversity architecture).
- Following channel(s) was (were) selected for the final test as listed below.

EUT CONFIGURE MODE	MODE	AVAILABLE CHANNEL	TESTED CHANNEL	MODULATION TECHNOLOGY	MODULATION TYPE	DATA RATE (Mbps)
-	802.11b	1 to 11	1, 6, 11	DSSS	DBPSK	1.0
-	802.11g	1 to 11	1, 6, 11	OFDM	BPSK	6.0
-	802.11n (20MHz)	1 to 11	1, 6, 11	OFDM	BPSK	6.5

#### **TEST CONDITION:**

APPLICABLE TO	ENVIRONMENTAL CONDITIONS	INPUT POWER	TESTED BY
RE <sup>3</sup> 1G	24deg. C, 74%RH	120Vac, 60Hz	Saxon Lee
RE<1G	24deg. C, 74%RH	120Vac, 60Hz	Saxon Lee
PLC	25deg. C, 75%RH	120Vac, 60Hz	Joey Liu
APCM	25deg. C, 74%RH	120Vac, 60Hz	Dalen Dai
OB	25deg. C, 74%RH	120Vac, 60Hz	Dalen Dai

### 3.3 DESCRIPTION OF SUPPORT UNITS

The EUT has been tested as an independent unit together without any necessary accessory or support unit.

#### 3.3.1 CONFIGURATION OF SYSTEM UNDER TEST

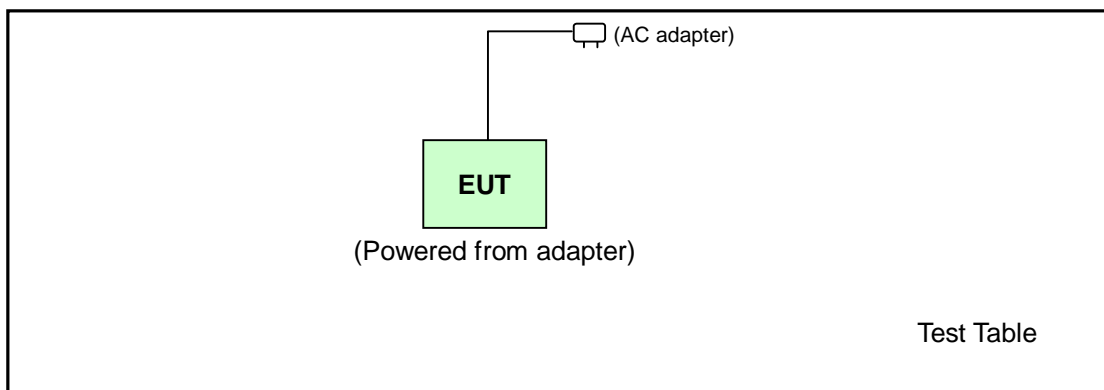



A D T

### **3.4 GENERAL DESCRIPTION OF APPLIED STANDARDS**

The EUT is a RF Product. According to the specifications of the manufacturer, it must comply with the requirements of the following standards:

**FCC Part 15, Subpart C (15.247)**

**558074 D01 DTS Meas Guidance v03r01**

**ANSI C63.10-2009**

All test items have been performed and recorded as per the above standards.

**NOTE:** The product has been verified to comply with the requirements of FCC Part 15, Subpart B, Class B (DoC). The test report has been issued separately.



## 4. TEST TYPES AND RESULTS

### 4.1 RADIATED EMISSION AND BANDEDGE MEASUREMENT

#### 4.1.1 LIMITS OF RADIATED EMISSION AND BANDEDGE MEASUREMENT

Radiated emissions which fall in the restricted bands must comply with the radiated emission limits specified as below table. Other emissions shall be at least 20dB below the highest level of the desired power:

FREQUENCIES (MHz)	FIELD STRENGTH (microvolts/meter)	MEASUREMENT DISTANCE (meters)
0.009 ~ 0.490	2400/F(kHz)	300
0.490 ~ 1.705	24000/F(kHz)	30
1.705 ~ 30.0	30	30
30 ~ 88	100	3
88 ~ 216	150	3
216 ~ 960	200	3
Above 960	500	3

**NOTE:**

1. The lower limit shall apply at the transition frequencies.
2. Emission level (dBuV/m) = 20 log Emission level (uV/m).
3. For frequencies above 1000MHz, the field strength limits are based on average detector, however, the peak field strength of any emission shall not exceed the maximum permitted average limits, specified above by more than 20dB under any condition of modulation.



A D T

#### 4.1.2 TEST INSTRUMENTS

DESCRIPTION & MANUFACTURER	MODEL NO.	SERIAL NO.	CALIBRATED DATE	CALIBRATED UNTIL
HP Preamplifier	8447D	2432A03504	Feb. 26, 2013	Feb. 25, 2014
HP Preamplifier	8449B	3008A01201	Feb. 26, 2013	Feb. 25, 2014
Agilent TEST RECEIVER	N9038A	MY51210129	Jan. 03, 2013	Jan. 02, 2014
Schwarzbeck Antenna	VULB 9168	137	Mar. 20, 2013	Mar. 19, 2014
Schwarzbeck Antenna	VHBA 9123	480	May 29, 2013	May 28, 2014
ADT. Turn Table	TT100	0306	NA	NA
ADT. Tower	AT100	0306	NA	NA
Software	ADT_Radiated_V 7.6.15.9.2	NA	NA	NA
SUHNER RF cable	SF102	CABLE-CH6	Aug. 19, 2012	Aug. 18, 2013
Schwarzbeck Horn Antenna	BBHA 9120-D1	D130	May 13, 2013	May 12, 2014
Highpass filter Wainwright Instruments	WHK 3.1/18G-10SS	SN 8	NA	NA
ROHDE & SCHWARZ Spectrum Analyzer	FSP 40	100036	May 17, 2013	May 16, 2014
Anritsu Power Sensor	MA2411B	0738404	Apr. 24, 2013	Apr. 23, 2014
Anritsu Power Meter	ML2495A	0842014	Apr. 25, 2013	Apr. 24, 2014

- NOTE:** 1. The calibration interval of the above test instruments is 12 months. And the calibrations are traceable to NML/ROC and NIST/USA.
2. The horn antenna and HP preamplifier (model: 8449B) are used only for the measurement of emission frequency above 1GHz if tested.
3. The test was performed in Chamber No. 6.
4. The Industry Canada Reference No. IC 7450E-6.
5. The FCC Site Registration No. is 447212.



### 4.1.3 TEST PROCEDURES

- a. The EUT was placed on the top of a rotating table 0.8 meters above the ground at a 3 meters semi-anechoic chamber. The table was rotated 360 degrees to determine the position of the highest radiation.
- b. The EUT was set 3 meters away from the interference-receiving antenna, which was mounted on the top of a variable-height antenna tower.
- c. The height of antenna is varied from one meter to four meters above the ground to determine the maximum value of the field strength. Both horizontal and vertical polarizations of the antenna are set to make the measurement.
- d. For each suspected emission, the EUT was arranged to its worst case and then the antenna was tuned to heights from 1 meter to 4 meters and the rotatable table was turned from 0 degrees to 360 degrees to find the maximum reading.
- e. The test-receiver system was set to Peak Detect Function and Specified Bandwidth with Maximum Hold Mode.
- f. If the emission level of the EUT in peak mode was lower than the limit specified, then testing could be stopped and the peak values of the EUT would be reported. Otherwise the emissions would be re-tested one by one using peak, quasi-peak or average method as specified and then reported in a data sheet.

**NOTE:**

1. The resolution bandwidth and video bandwidth of test receiver/spectrum analyzer is 120kHz for Quasi-peak detection at frequency below 1GHz.
2. The resolution bandwidth of test receiver/spectrum analyzer is 100kHz and video bandwidth is 300kHz for Peak detection at frequency above 1GHz.
3. The resolution bandwidth of test receiver/spectrum analyzer is 1MHz and the video bandwidth is 1kHz for Average detection (AV) at frequency above 1GHz.
4. All modes of operation were investigated and the worst-case emissions are reported.

### 4.1.4 DEVIATION FROM TEST STANDARD

No deviation.



#### 4.1.5 TEST SETUP

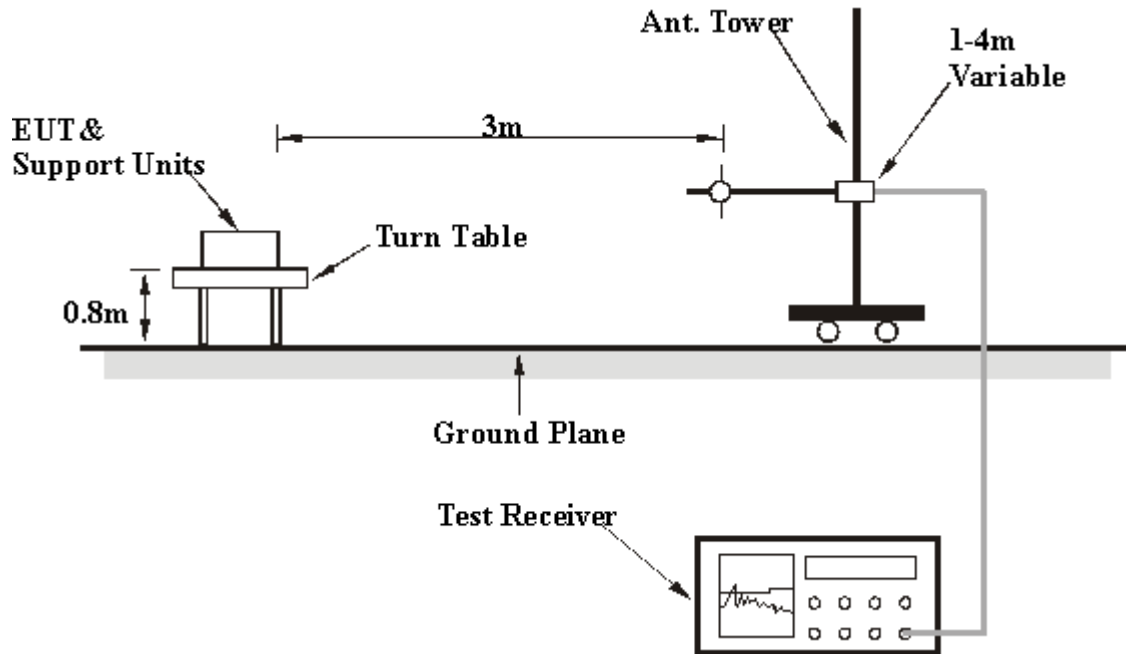

For the actual test configuration, please refer to the attached file (Test Setup Photo).

#### 4.1.6 EUT OPERATING CONDITIONS

Set the EUT under transmission/receiving condition continuously at specific channel frequency.



A D T

## 4.1.7 TEST RESULTS

### BELOW 1GHz WORST-CASE DATA

#### 802.11g

<b>CHANNEL</b>	TX Channel 11	<b>DETECTOR FUNCTION</b>	Quasi-Peak (QP)
<b>FREQUENCY RANGE</b>	30MHz ~ 1GHz		

ANTENNA POLARITY & TEST DISTANCE: HORIZONTAL AT 3 M								
NO.	FREQ. (MHz)	EMISSION LEVEL (dBuV/m)	LIMIT (dBuV/m)	MARGIN (dB)	ANTENNA HEIGHT (m)	TABLE ANGLE (Degree)	RAW VALUE (dBuV)	CORRECTION FACTOR (dB/m)
1	137.00	41.5 QP	43.5	-2.0	1.47 H	276	55.45	-13.97
2	191.02	41.3 QP	43.5	-2.2	1.00 H	62	57.07	-15.77
3	248.56	45.0 QP	46.0	-1.1	1.00 H	199	58.56	-13.61
4	465.53	38.2 QP	46.0	-7.8	2.00 H	58	46.23	-8.03
5	545.07	36.3 QP	46.0	-9.7	2.00 H	258	43.12	-6.78
6	719.67	35.9 QP	46.0	-10.1	1.00 H	218	39.36	-3.47

ANTENNA POLARITY & TEST DISTANCE: VERTICAL AT 3 M								
NO.	FREQ. (MHz)	EMISSION LEVEL (dBuV/m)	LIMIT (dBuV/m)	MARGIN (dB)	ANTENNA HEIGHT (m)	TABLE ANGLE (Degree)	RAW VALUE (dBuV)	CORRECTION FACTOR (dB/m)
1	54.25	37.5 QP	40.0	-2.6	1.03 V	123	50.64	-13.19
2	72.68	38.0 QP	40.0	-2.0	1.04 V	66	53.94	-15.96
3	133.79	39.8 QP	43.5	-3.7	1.08 V	160	53.92	-14.15
4	165.80	38.2 QP	43.5	-5.3	1.06 V	219	51.73	-13.57
5	210.42	37.8 QP	43.5	-5.7	1.51 V	176	53.43	-15.65
6	248.25	41.9 QP	46.0	-4.1	1.00 V	48	55.53	-13.64

#### REMARKS:

1. Emission Level(dBuV/m) = Raw Value(dBuV) + Correction Factor(dB/m)
2. Correction Factor(dB/m) = Antenna Factor(dB/m) + Cable Factor(dB) – Pre-Amplifier Factor(dB)
3. The other emission levels were very low against the limit.
4. Margin value = Emission Level – Limit value



A D T

**ABOVE 1GHz DATA**

**802.11b**

<b>CHANNEL</b>	TX Channel 1	<b>DETECTOR FUNCTION</b>	Peak (PK)
<b>FREQUENCY RANGE</b>	1GHz ~ 25GHz		Average (AV)

<b>ANTENNA POLARITY &amp; TEST DISTANCE: HORIZONTAL AT 3 M</b>								
NO.	FREQ. (MHz)	EMISSION LEVEL (dBuV/m)	LIMIT (dBuV/m)	MARGIN (dB)	ANTENNA HEIGHT (m)	TABLE ANGLE (Degree)	RAW VALUE (dBuV)	CORRECTION FACTOR (dB/m)
1	2390.00	59.8 PK	74.0	-14.2	1.04 H	62	63.56	-3.75
2	2390.00	46.9 AV	54.0	-7.1	1.04 H	62	50.68	-3.75
3	*2412.00	104.0 PK			1.04 H	62	107.62	-3.64
4	*2412.00	99.8 AV			1.04 H	62	103.48	-3.64
5	4824.00	53.8 PK	74.0	-20.2	1.07 H	106	50.08	3.73
6	4824.00	50.0 AV	54.0	-4.0	1.07 H	106	46.27	3.73

<b>ANTENNA POLARITY &amp; TEST DISTANCE: VERTICAL AT 3 M</b>								
NO.	FREQ. (MHz)	EMISSION LEVEL (dBuV/m)	LIMIT (dBuV/m)	MARGIN (dB)	ANTENNA HEIGHT (m)	TABLE ANGLE (Degree)	RAW VALUE (dBuV)	CORRECTION FACTOR (dB/m)
1	2390.00	58.9 PK	74.0	-15.1	1.00 V	334	62.63	-3.75
2	2390.00	46.1 AV	54.0	-7.9	1.00 V	334	49.89	-3.75
3	*2412.00	103.6 PK			1.00 V	334	107.22	-3.64
4	*2412.00	98.9 AV			1.00 V	334	102.55	-3.64
5	4824.00	56.8 PK	74.0	-17.2	1.00 V	146	53.11	3.73
6	4824.00	52.7 AV	54.0	-1.3	1.00 V	146	48.99	3.73

**REMARKS:**

1. Emission Level(dBuV/m) = Raw Value(dBuV) + Correction Factor(dB/m)
2. Correction Factor(dB/m) = Antenna Factor(dB/m) + Cable Factor(dB) – Pre-Amplifier Factor(dB)
3. The other emission levels were very low against the limit.
4. Margin value = Emission Level – Limit value
5. " \* ": Fundamental frequency.



A D T

<b>CHANNEL</b>	TX Channel 6	<b>DETECTOR FUNCTION</b>	Peak (PK)
<b>FREQUENCY RANGE</b>	1GHz ~ 25GHz		Average (AV)

ANTENNA POLARITY & TEST DISTANCE: HORIZONTAL AT 3 M								
NO.	FREQ. (MHz)	EMISSION LEVEL (dBuV/m)	LIMIT (dBuV/m)	MARGIN (dB)	ANTENNA HEIGHT (m)	TABLE ANGLE (Degree)	RAW VALUE (dBuV)	CORRECTION FACTOR (dB/m)
1	*2437.00	104.6 PK			1.02 H	63	108.13	-3.53
2	*2437.00	100.3 AV			1.02 H	63	103.82	-3.53
3	4874.00	54.3 PK	74.0	-19.7	1.20 H	99	50.52	3.75
4	4874.00	50.8 AV	54.0	-3.2	1.20 H	99	47.04	3.75

ANTENNA POLARITY & TEST DISTANCE: VERTICAL AT 3 M								
NO.	FREQ. (MHz)	EMISSION LEVEL (dBuV/m)	LIMIT (dBuV/m)	MARGIN (dB)	ANTENNA HEIGHT (m)	TABLE ANGLE (Degree)	RAW VALUE (dBuV)	CORRECTION FACTOR (dB/m)
1	*2437.00	103.3 PK			1.00 V	333	106.80	-3.53
2	*2437.00	98.7 AV			1.00 V	333	102.18	-3.53
3	4874.00	56.6 PK	74.0	-17.4	1.00 V	203	52.81	3.75
4	4874.00	52.4 AV	54.0	-1.6	1.00 V	203	48.66	3.75

**REMARKS:**

1. Emission Level(dBuV/m) = Raw Value(dBuV) + Correction Factor(dB/m)
2. Correction Factor(dB/m) = Antenna Factor(dB/m) + Cable Factor(dB) – Pre-Amplifier Factor(dB)
3. The other emission levels were very low against the limit.
4. Margin value = Emission Level – Limit value
5. " \* ": Fundamental frequency.



A D T

<b>CHANNEL</b>	TX Channel 11	<b>DETECTOR FUNCTION</b>	Peak (PK)
<b>FREQUENCY RANGE</b>	1GHz ~ 25GHz		Average (AV)

ANTENNA POLARITY & TEST DISTANCE: HORIZONTAL AT 3 M								
NO.	FREQ. (MHz)	EMISSION LEVEL (dBuV/m)	LIMIT (dBuV/m)	MARGIN (dB)	ANTENNA HEIGHT (m)	TABLE ANGLE (Degree)	RAW VALUE (dBuV)	CORRECTION FACTOR (dB/m)
1	*2462.00	104.6 PK			1.13 H	32	107.98	-3.41
2	*2462.00	100.1 AV			1.13 H	32	103.53	-3.41
3	2483.50	60.6 PK	74.0	-13.5	1.13 H	32	63.87	-3.32
4	2483.50	48.7 AV	54.0	-5.3	1.13 H	32	52.04	-3.32
5	4924.00	54.6 PK	74.0	-19.4	1.25 H	95	50.87	3.74
6	4924.00	51.4 AV	54.0	-2.6	1.25 H	95	47.64	3.74
ANTENNA POLARITY & TEST DISTANCE: VERTICAL AT 3 M								
NO.	FREQ. (MHz)	EMISSION LEVEL (dBuV/m)	LIMIT (dBuV/m)	MARGIN (dB)	ANTENNA HEIGHT (m)	TABLE ANGLE (Degree)	RAW VALUE (dBuV)	CORRECTION FACTOR (dB/m)
1	*2462.00	103.0 PK			1.00 V	326	106.43	-3.41
2	*2462.00	98.7 AV			1.00 V	326	102.10	-3.41
3	2483.50	60.1 PK	74.0	-13.9	1.00 V	326	63.40	-3.32
4	2483.50	47.4 AV	54.0	-6.7	1.00 V	326	50.67	-3.32
5	4924.00	56.4 PK	74.0	-17.6	1.00 V	148	52.67	3.74
6	4924.00	53.5 AV	54.0	-0.5	1.00 V	148	49.77	3.74

**REMARKS:**

1. Emission Level(dBuV/m) = Raw Value(dBuV) + Correction Factor(dB/m)
2. Correction Factor(dB/m) = Antenna Factor(dB/m) + Cable Factor(dB) – Pre-Amplifier Factor(dB)
3. The other emission levels were very low against the limit.
4. Margin value = Emission Level – Limit value
5. " \* ": Fundamental frequency.



A D T

802.11g

<b>CHANNEL</b>	TX Channel 1	<b>DETECTOR FUNCTION</b>	Peak (PK)
<b>FREQUENCY RANGE</b>	1GHz ~ 25GHz		Average (AV)

ANTENNA POLARITY & TEST DISTANCE: HORIZONTAL AT 3 M								
NO.	FREQ. (MHz)	EMISSION LEVEL (dBuV/m)	LIMIT (dBuV/m)	MARGIN (dB)	ANTENNA HEIGHT (m)	TABLE ANGLE (Degree)	RAW VALUE (dBuV)	CORRECTION FACTOR (dB/m)
1	2390.00	65.9 PK	74.0	-8.1	1.06 H	63	69.66	-3.75
2	2390.00	49.3 AV	54.0	-4.7	1.06 H	63	53.02	-3.75
3	*2412.00	107.0 PK			1.06 H	63	110.66	-3.64
4	*2412.00	91.2 AV			1.06 H	63	94.88	-3.64
5	4824.00	56.4 PK	74.0	-17.6	1.02 H	100	52.68	3.73
6	4824.00	40.8 AV	54.0	-13.2	1.02 H	100	37.05	3.73
ANTENNA POLARITY & TEST DISTANCE: VERTICAL AT 3 M								
NO.	FREQ. (MHz)	EMISSION LEVEL (dBuV/m)	LIMIT (dBuV/m)	MARGIN (dB)	ANTENNA HEIGHT (m)	TABLE ANGLE (Degree)	RAW VALUE (dBuV)	CORRECTION FACTOR (dB/m)
1	2390.00	66.7 PK	74.0	-7.3	1.00 V	334	70.47	-3.75
2	2390.00	48.6 AV	54.0	-5.4	1.00 V	334	52.34	-3.75
3	*2412.00	104.8 PK			1.00 V	334	108.41	-3.64
4	*2412.00	88.9 AV			1.00 V	334	92.51	-3.64
5	4824.00	59.6 PK	74.0	-14.5	1.03 V	157	55.82	3.73
6	4824.00	42.7 AV	54.0	-11.3	1.03 V	157	38.97	3.73

**REMARKS:**

1. Emission Level(dBuV/m) = Raw Value(dBuV) + Correction Factor(dB/m)
2. Correction Factor(dB/m) = Antenna Factor(dB/m) + Cable Factor(dB) – Pre-Amplifier Factor(dB)
3. The other emission levels were very low against the limit.
4. Margin value = Emission Level – Limit value
5. " \* " : Fundamental frequency.



A D T

<b>CHANNEL</b>	TX Channel 6	<b>DETECTOR FUNCTION</b>	Peak (PK)
<b>FREQUENCY RANGE</b>	1GHz ~ 25GHz		Average (AV)

ANTENNA POLARITY & TEST DISTANCE: HORIZONTAL AT 3 M								
NO.	FREQ. (MHz)	EMISSION LEVEL (dBuV/m)	LIMIT (dBuV/m)	MARGIN (dB)	ANTENNA HEIGHT (m)	TABLE ANGLE (Degree)	RAW VALUE (dBuV)	CORRECTION FACTOR (dB/m)
1	*2437.00	107.0 PK			1.06 H	65	110.57	-3.53
2	*2437.00	90.9 AV			1.06 H	65	94.47	-3.53
3	4874.00	56.1 PK	74.0	-17.9	1.00 H	106	52.33	3.75
4	4874.00	40.3 AV	54.0	-13.7	1.00 H	106	36.52	3.75

ANTENNA POLARITY & TEST DISTANCE: VERTICAL AT 3 M								
NO.	FREQ. (MHz)	EMISSION LEVEL (dBuV/m)	LIMIT (dBuV/m)	MARGIN (dB)	ANTENNA HEIGHT (m)	TABLE ANGLE (Degree)	RAW VALUE (dBuV)	CORRECTION FACTOR (dB/m)
1	*2437.00	104.9 PK			1.00 V	331	108.39	-3.53
2	*2437.00	89.4 AV			1.00 V	331	92.88	-3.53
3	4874.00	59.2 PK	74.0	-14.8	1.02 V	153	55.41	3.75
4	4874.00	42.3 AV	54.0	-11.7	1.02 V	153	38.58	3.75

**REMARKS:**

1. Emission Level(dBuV/m) = Raw Value(dBuV) + Correction Factor(dB/m)
2. Correction Factor(dB/m) = Antenna Factor(dB/m) + Cable Factor(dB) – Pre-Amplifier Factor(dB)
3. The other emission levels were very low against the limit.
4. Margin value = Emission Level – Limit value
5. " \* ": Fundamental frequency.



A D T

<b>CHANNEL</b>	TX Channel 11	<b>DETECTOR FUNCTION</b>	Peak (PK)
<b>FREQUENCY RANGE</b>	1GHz ~ 25GHz		Average (AV)

**ANTENNA POLARITY & TEST DISTANCE: HORIZONTAL AT 3 M**

NO.	FREQ. (MHz)	EMISSION LEVEL (dBuV/m)	LIMIT (dBuV/m)	MARGIN (dB)	ANTENNA HEIGHT (m)	TABLE ANGLE (Degree)	RAW VALUE (dBuV)	CORRECTION FACTOR (dB/m)
1	*2462.00	107.7 PK			1.05 H	64	111.14	-3.41
2	*2462.00	92.2 AV			1.05 H	64	95.59	-3.41
3	2483.50	70.7 PK	74.0	-3.3	1.05 H	64	74.01	-3.32
4	2483.50	51.1 AV	54.0	-2.9	1.05 H	64	54.40	-3.32
5	4924.00	56.4 PK	74.0	-17.6	1.01 H	98	52.64	3.74
6	4924.00	40.7 AV	54.0	-13.3	1.01 H	98	36.95	3.74

**ANTENNA POLARITY & TEST DISTANCE: VERTICAL AT 3 M**

NO.	FREQ. (MHz)	EMISSION LEVEL (dBuV/m)	LIMIT (dBuV/m)	MARGIN (dB)	ANTENNA HEIGHT (m)	TABLE ANGLE (Degree)	RAW VALUE (dBuV)	CORRECTION FACTOR (dB/m)
1	*2462.00	107.1 PK			1.00 V	326	110.53	-3.41
2	*2462.00	89.9 AV			1.00 V	326	93.29	-3.41
3	2483.50	67.3 PK	74.0	-6.7	1.00 V	326	70.64	-3.32
4	2483.50	49.3 AV	54.0	-4.8	1.00 V	326	52.57	-3.32
5	4924.00	59.6 PK	74.0	-14.4	1.04 V	162	55.82	3.74
6	4924.00	42.8 AV	54.0	-11.2	1.04 V	162	39.02	3.74

**REMARKS:**

1. Emission Level(dBuV/m) = Raw Value(dBuV) + Correction Factor(dB/m)
2. Correction Factor(dB/m) = Antenna Factor(dB/m) + Cable Factor(dB) – Pre-Amplifier Factor(dB)
3. The other emission levels were very low against the limit.
4. Margin value = Emission Level – Limit value
5. " \* ": Fundamental frequency.





A D T

802.11n (20MHz)

<b>CHANNEL</b>	TX Channel 1	<b>DETECTOR FUNCTION</b>	Peak (PK)
<b>FREQUENCY RANGE</b>	1GHz ~ 25GHz		Average (AV)

ANTENNA POLARITY & TEST DISTANCE: HORIZONTAL AT 3 M								
NO.	FREQ. (MHz)	EMISSION LEVEL (dBuV/m)	LIMIT (dBuV/m)	MARGIN (dB)	ANTENNA HEIGHT (m)	TABLE ANGLE (Degree)	RAW VALUE (dBuV)	CORRECTION FACTOR (dB/m)
1	2390.00	69.4 PK	74.0	-4.6	1.02 H	55	73.19	-3.75
2	2390.00	50.7 AV	54.0	-3.3	1.02 H	55	54.47	-3.75
3	*2412.00	107.9 PK			1.02 H	55	111.58	-3.64
4	*2412.00	91.1 AV			1.02 H	55	94.69	-3.64
5	4824.00	56.6 PK	74.0	-17.4	1.00 H	103	52.89	3.73
6	4824.00	40.9 AV	54.0	-13.1	1.00 H	103	37.14	3.73
ANTENNA POLARITY & TEST DISTANCE: VERTICAL AT 3 M								
NO.	FREQ. (MHz)	EMISSION LEVEL (dBuV/m)	LIMIT (dBuV/m)	MARGIN (dB)	ANTENNA HEIGHT (m)	TABLE ANGLE (Degree)	RAW VALUE (dBuV)	CORRECTION FACTOR (dB/m)
1	2390.00	65.6 PK	74.0	-8.4	1.00 V	333	69.38	-3.75
2	2390.00	48.8 AV	54.0	-5.2	1.00 V	333	52.58	-3.75
3	*2412.00	106.0 PK			1.00 V	333	109.64	-3.64
4	*2412.00	88.5 AV			1.00 V	333	92.09	-3.64
5	4824.00	59.2 PK	74.0	-14.8	1.02 V	152	55.51	3.73
6	4824.00	42.9 AV	54.0	-11.1	1.02 V	152	39.21	3.73

**REMARKS:**

1. Emission Level(dBuV/m) = Raw Value(dBuV) + Correction Factor(dB/m)
2. Correction Factor(dB/m) = Antenna Factor(dB/m) + Cable Factor(dB) – Pre-Amplifier Factor(dB)
3. The other emission levels were very low against the limit.
4. Margin value = Emission Level – Limit value
5. " \* " : Fundamental frequency.



A D T

<b>CHANNEL</b>	TX Channel 6	<b>DETECTOR FUNCTION</b>	Peak (PK)
<b>FREQUENCY RANGE</b>	1GHz ~ 25GHz		Average (AV)

ANTENNA POLARITY & TEST DISTANCE: HORIZONTAL AT 3 M								
NO.	FREQ. (MHz)	EMISSION LEVEL (dBuV/m)	LIMIT (dBuV/m)	MARGIN (dB)	ANTENNA HEIGHT (m)	TABLE ANGLE (Degree)	RAW VALUE (dBuV)	CORRECTION FACTOR (dB/m)
1	*2437.00	107.5 PK			1.03 H	61	111.06	-3.53
2	*2437.00	90.5 AV			1.03 H	61	94.00	-3.53
3	4874.00	56.1 PK	74.0	-17.9	1.02 H	100	52.38	3.75
4	4874.00	40.4 AV	54.0	-13.6	1.02 H	100	36.64	3.75

ANTENNA POLARITY & TEST DISTANCE: VERTICAL AT 3 M								
NO.	FREQ. (MHz)	EMISSION LEVEL (dBuV/m)	LIMIT (dBuV/m)	MARGIN (dB)	ANTENNA HEIGHT (m)	TABLE ANGLE (Degree)	RAW VALUE (dBuV)	CORRECTION FACTOR (dB/m)
1	*2437.00	105.8 PK			1.00 V	330	109.28	-3.53
2	*2437.00	88.4 AV			1.00 V	330	91.92	-3.53
3	4874.00	59.2 PK	74.0	-14.8	1.01 V	148	55.48	3.75
4	4874.00	42.4 AV	54.0	-11.7	1.01 V	148	38.60	3.75

**REMARKS:**

1. Emission Level(dBuV/m) = Raw Value(dBuV) + Correction Factor(dB/m)
2. Correction Factor(dB/m) = Antenna Factor(dB/m) + Cable Factor(dB) – Pre-Amplifier Factor(dB)
3. The other emission levels were very low against the limit.
4. Margin value = Emission Level – Limit value
5. " \* ": Fundamental frequency.



A D T

<b>CHANNEL</b>	TX Channel 11	<b>DETECTOR FUNCTION</b>	Peak (PK)
<b>FREQUENCY RANGE</b>	1GHz ~ 25GHz		Average (AV)

**ANTENNA POLARITY & TEST DISTANCE: HORIZONTAL AT 3 M**

NO.	FREQ. (MHz)	EMISSION LEVEL (dBuV/m)	LIMIT (dBuV/m)	MARGIN (dB)	ANTENNA HEIGHT (m)	TABLE ANGLE (Degree)	RAW VALUE (dBuV)	CORRECTION FACTOR (dB/m)
1	*2462.00	108.8 PK			1.03 H	59	112.21	-3.41
2	*2462.00	92.8 AV			1.03 H	59	96.17	-3.41
3	2483.50	70.7 PK	74.0	-3.3	1.03 H	59	74.03	-3.32
4	2483.50	51.4 AV	54.0	-2.6	1.03 H	59	54.71	-3.32
5	4924.00	56.4 PK	74.0	-17.6	1.00 H	103	52.68	3.74
6	4924.00	40.7 AV	54.0	-13.3	1.00 H	103	36.97	3.74

**ANTENNA POLARITY & TEST DISTANCE: VERTICAL AT 3 M**

NO.	FREQ. (MHz)	EMISSION LEVEL (dBuV/m)	LIMIT (dBuV/m)	MARGIN (dB)	ANTENNA HEIGHT (m)	TABLE ANGLE (Degree)	RAW VALUE (dBuV)	CORRECTION FACTOR (dB/m)
1	*2462.00	106.2 PK			1.01 V	332	109.60	-3.41
2	*2462.00	88.7 AV			1.01 V	332	92.09	-3.41
3	2483.50	67.5 PK	74.0	-6.5	1.01 V	332	70.80	-3.32
4	2483.50	49.6 AV	54.0	-4.4	1.01 V	332	52.91	-3.32
5	4924.00	59.4 PK	74.0	-14.6	1.02 V	68	55.70	3.74
6	4924.00	42.6 AV	54.0	-11.4	1.02 V	68	38.89	3.74

**REMARKS:**

1. Emission Level(dBuV/m) = Raw Value(dBuV) + Correction Factor(dB/m)
2. Correction Factor(dB/m) = Antenna Factor(dB/m) + Cable Factor(dB) – Pre-Amplifier Factor(dB)
3. The other emission levels were very low against the limit.
4. Margin value = Emission Level – Limit value
5. " \* ": Fundamental frequency.



A D T

## 4.2 CONDUCTED EMISSION MEASUREMENT

### 4.2.1 LIMITS OF CONDUCTED EMISSION MEASUREMENT

FREQUENCY OF EMISSION (MHz)	CONDUCTED LIMIT (dB $\mu$ V)	
	Quasi-peak	Average
0.15 ~ 0.5	66 to 56	56 to 46
0.5 ~ 5	56	46
5 ~ 30	60	50

**NOTE:** 1. The lower limit shall apply at the transition frequencies.

2. The limit decreases in line with the logarithm of the frequency in the range of 0.15 to 0.50MHz.

### 4.2.2 TEST INSTRUMENTS

DESCRIPTION & MANUFACTURER	MODEL NO.	SERIAL NO.	CALIBRATED DATE	CALIBRATED UNTIL
ROHDE & SCHWARZ TEST RECEIVER	ESCS 30	100276	Jan. 07, 2013	Jan. 06, 2014
ROHDE & SCHWARZ Artificial Mains Network (for EUT)	ESH3-Z5	100219	Nov. 28, 2012	Nov. 27, 2013
LISN With Adapter (for EUT)	AD10	C10Ada-001	Nov. 28, 2012	Nov. 27, 2013
ROHDE & SCHWARZ Artificial Mains Network (for peripherals)	ESH3-Z5	100218	Dec. 05, 2012	Dec. 04, 2013
Software	ADT_Cond_V7.3.7	NA	NA	NA
Software	ADT_ISN_V7.3.7	NA	NA	NA
RF cable (JYEBAO)	5D-FB	Cable-C10.01	Feb. 19, 2013	Feb. 18, 2014
SUHNER Terminator (For ROHDE & SCHWARZ LISN)	65BNC-5001	E1-010773	Feb. 06, 2013	Feb. 05, 2014

**NOTE:** 1. The calibration interval of the above test instruments is 12 months and the calibrations are traceable to NML/ROC and NIST/USA.

2. The test was performed in Shielded Room No. 10.

3. The VCCI Site Registration No. C-1852.



A D T

### 4.2.3 TEST PROCEDURES

- a. The EUT was placed 0.4 meters from the conducting wall of the shielded room with EUT being connected to the power mains through a line impedance stabilization network (LISN). Other support units were connected to the power mains through another LISN. The two LISNs provide 50 ohm/ 50uH of coupling impedance for the measuring instrument.
- b. Both lines of the power mains connected to the EUT were checked for maximum conducted interference.
- c. The frequency range from 150kHz to 30MHz was searched. Emission levels under (Limit - 20dB) was not recorded.

**NOTE:** All modes of operation were investigated and the worst-case emissions are reported.

### 4.2.4 DEVIATION FROM TEST STANDARD

No deviation.

## 4.2.5 TEST SETUP

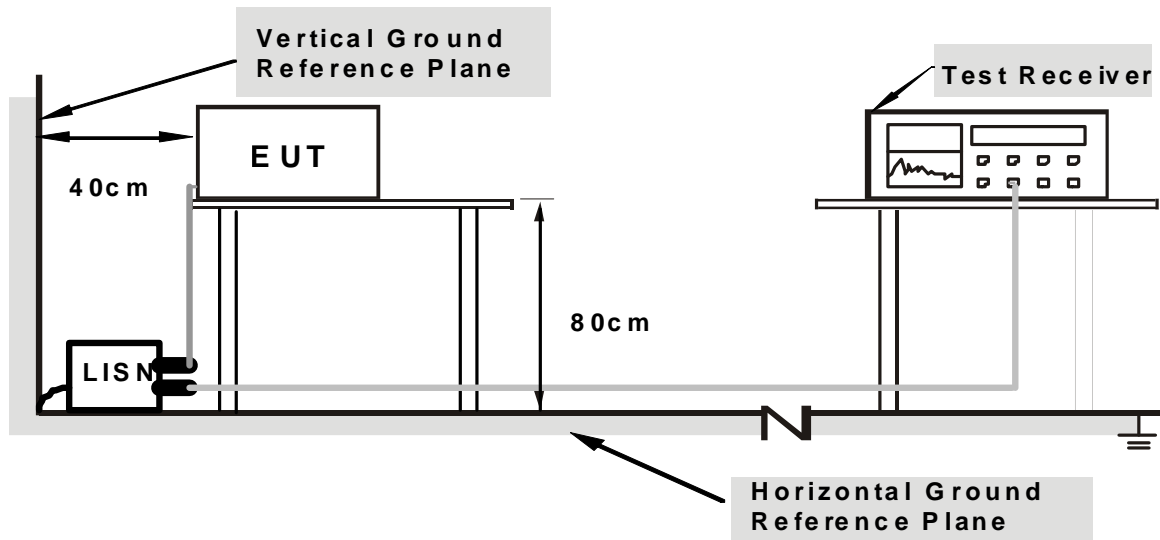

**Note:** Support units were connected to second LISN.

For the actual test configuration, please refer to the attached file (Test Setup Photo).

## 4.2.6 EUT OPERATING CONDITIONS

Same as item 4.1.6.

## 4.2.7 TEST RESULTS

### CONDUCTED WORST-CASE DATA : 802.11g

PHASE	Line 1	6dB BANDWIDTH	9kHz
-------	--------	---------------	------

No	Freq. [MHz]	Corr. Factor (dB)	Reading Value [dB (uV)]		Emission Level [dB (uV)]		Limit [dB (uV)]		Margin (dB)	
			Q.P.	AV.	Q.P.	AV.	Q.P.	AV.	Q.P.	AV.
			1	0.18906	0.14	43.44	30.50	43.58	30.64	64.08
2	0.38047	0.17	37.62	18.82	37.79	18.99	58.27	48.27	-20.48	-29.28
3	0.97813	0.19	39.06	20.91	39.25	21.10	56.00	46.00	-16.75	-24.90
4	1.75000	0.22	41.51	24.72	41.73	24.94	56.00	46.00	-14.27	-21.06
5	2.43359	0.25	43.51	27.99	43.76	28.24	56.00	46.00	-12.24	-17.76
6	7.49219	0.51	31.78	17.33	32.29	17.84	60.00	50.00	-27.71	-32.16

#### REMARKS:

1. Q.P. and AV. are abbreviations of quasi-peak and average individually.
2. The emission levels of other frequencies were very low against the limit.
3. Margin value = Emission Level – Limit value
4. Correction Factor = Insertion loss + Cable loss
5. Emission Level = Correction Factor + Reading Value

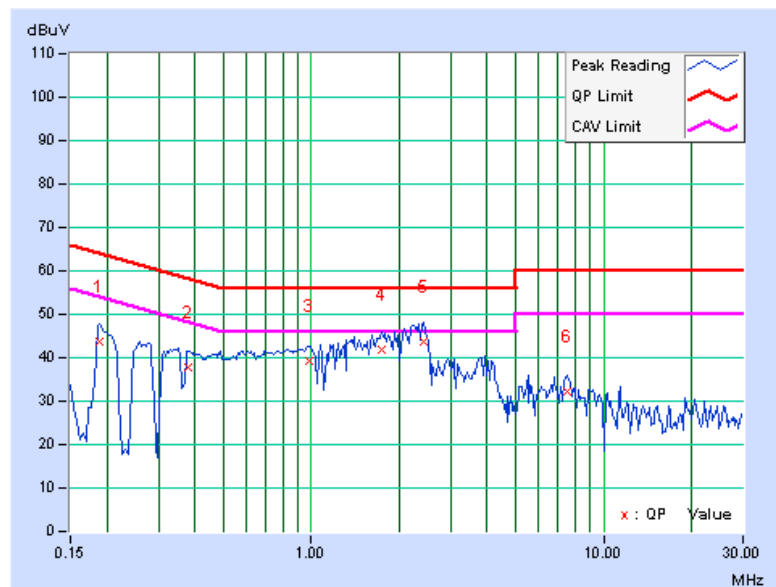



A D T

PHASE	Line 2	6dB BANDWIDTH	9kHz
-------	--------	---------------	------

No	Freq. [MHz]	Corr. Factor (dB)	Reading Value [dB (uV)]		Emission Level [dB (uV)]		Limit [dB (uV)]		Margin (dB)	
			Q.P.	AV.	Q.P.	AV.	Q.P.	AV.	Q.P.	AV.
			1	0.19450	0.11	41.56	27.72	41.67	27.83	63.84
2	0.34531	0.13	37.73	17.94	37.86	18.07	59.07	49.07	-21.21	-31.00
3	1.88672	0.19	42.06	24.86	42.25	25.05	56.00	46.00	-13.75	-20.95
<b>4</b>	<b>2.38672</b>	<b>0.20</b>	<b>45.58</b>	<b>31.56</b>	<b>45.78</b>	<b>31.76</b>	<b>56.00</b>	<b>46.00</b>	<b>-10.22</b>	<b>-14.24</b>
5	4.01172	0.26	36.66	26.45	36.92	26.71	56.00	46.00	-19.08	-19.29
6	5.57031	0.32	30.48	19.45	30.80	19.77	60.00	50.00	-29.20	-30.23

**REMARKS:**

1. Q.P. and AV. are abbreviations of quasi-peak and average individually.
2. The emission levels of other frequencies were very low against the limit.
3. Margin value = Emission Level – Limit value
4. Correction Factor = Insertion loss + Cable loss
5. Emission Level = Correction Factor + Reading Value

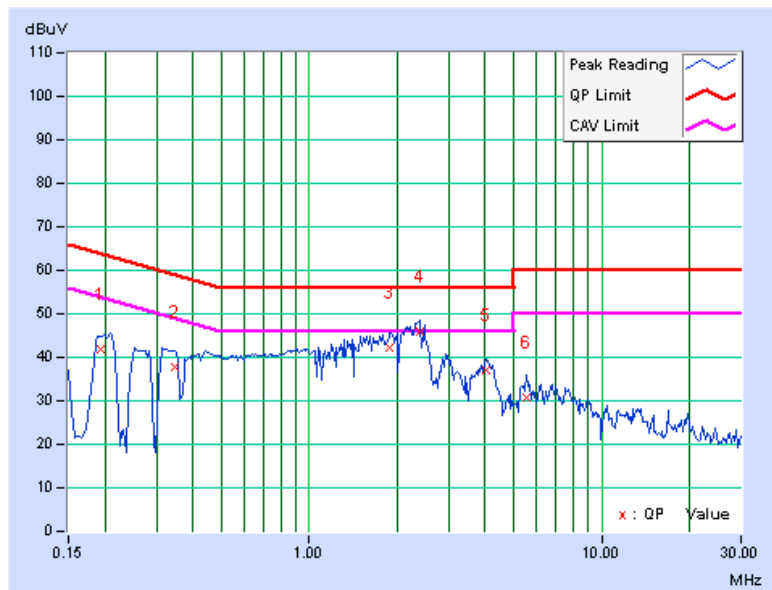



### 4.3 6dB BANDWIDTH MEASUREMENT

#### 4.3.1 LIMITS OF 6dB BANDWIDTH MEASUREMENT

The minimum of 6dB Bandwidth Measurement is 0.5 MHz.

#### 4.3.2 TEST SETUP

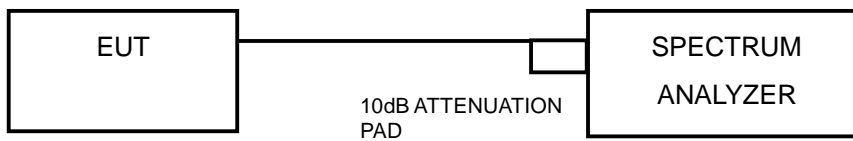

#### 4.3.3 TEST INSTRUMENTS

Refer to section 4.1.2 to get information of above instrument.

#### 4.3.4 TEST PROCEDURE

- a. Set resolution bandwidth (RBW) = 100kHz
- b. Set the video bandwidth (VBW)  $\geq 3 \times$  RBW, Detector = Peak.
- c. Trace mode = max hold.
- d. Sweep = auto couple.
- e. Measure the maximum width of the emission that is constrained by the frequencies associated with the two amplitude points (upper and lower) that are attenuated by 6 dB relative to the maximum level measured in the fundamental emission

#### 4.3.5 DEVIATION FROM TEST STANDARD

No deviation.

#### 4.3.6 EUT OPERATING CONDITIONS

The software provided by client to enable the EUT under transmission condition continuously at lowest, middle and highest channel frequencies individually.



### 4.3.7 TEST RESULTS

CHANNEL	CHANNEL FREQUENCY (MHz)	6dB BANDWIDTH (MHz)	MINIMUM LIMIT (MHz)	PASS / FAIL
<b>802.11b</b>				
1	2412	7.59	0.5	PASS
6	2437	7.15	0.5	PASS
11	2462	7.08	0.5	PASS
<b>802.11g</b>				
1	2412	15.15	0.5	PASS
6	2437	13.89	0.5	PASS
11	2462	15.18	0.5	PASS
<b>802.11n (20MHz)</b>				
1	2412	15.15	0.5	PASS
6	2437	15.17	0.5	PASS
11	2462	15.13	0.5	PASS

## 4.4 CONDUCTED OUTPUT POWER

### 4.4.1 LIMITS OF CONDUCTED OUTPUT POWER MEASUREMENT

For systems using digital modulation in the 2400–2483.5 MHz bands: 1 Watt (30dBm)

### 4.4.2 TEST SETUP

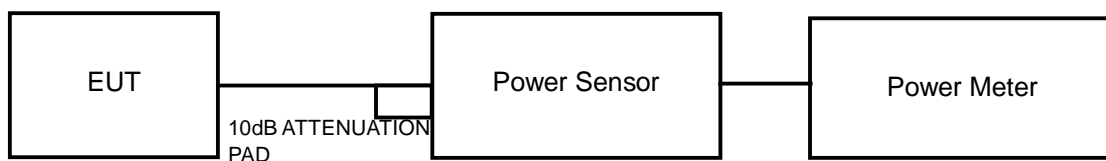

### 4.4.3 TEST INSTRUMENTS

Refer to section 4.1.2 to get information of above instrument.

### 4.4.4 TEST PROCEDURES

A peak / average power sensor were used on the output port of the EUT. A power meter was used to read the response of the peak / average power sensor. Record the peak power level.

### 4.4.5 DEVIATION FROM TEST STANDARD

No deviation.

### 4.4.6 EUT OPERATING CONDITIONS

Same as Item 4.3.6.



### 4.4.7 TEST RESULTS

#### FOR PEAK POWER

CHAN.	CHAN. FREQ. (MHz)	POWER OUTPUT (dBm)	POWER OUTPUT (mW)	POWER LIMIT (dBm)	PASS / FAIL
<b>802.11b</b>					
1	2412	17.09	51.2	30	PASS
6	2437	17.02	50.4	30	PASS
11	2462	17.06	50.8	30	PASS
<b>802.11g</b>					
1	2412	22.98	198.6	30	PASS
6	2437	22.52	178.6	30	PASS
11	2462	23.16	207.0	30	PASS
<b>802.11n (20MHz)</b>					
1	2412	22.97	198.2	30	PASS
6	2437	23.09	203.7	30	PASS
11	2462	23.14	206.1	30	PASS



A D T

**FOR AVERAGE POWER**

CHAN.	CHAN. FREQ. (MHz)	AVERAGE POWER (dBm)	AVERAGE POWER (mW)
<b>802.11b</b>			
1	2412	14.02	25.2
6	2437	13.85	24.3
11	2462	13.81	24.0
<b>802.11g</b>			
1	2412	14.89	30.8
6	2437	15.20	33.1
11	2462	15.32	34.0
<b>802.11n (20MHz)</b>			
1	2412	15.15	32.7
6	2437	15.14	32.7
11	2462	15.19	33.0

## **4.5 POWER SPECTRAL DENSITY MEASUREMENT**

### **4.5.1 LIMITS OF POWER SPECTRAL DENSITY MEASUREMENT**

The Maximum of Power Spectral Density Measurement is 8dBm.

### **4.5.2 TEST SETUP**

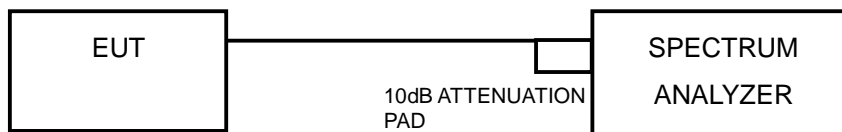

### **4.5.3 TEST INSTRUMENTS**

Refer to section 4.1.2 to get information of above instrument.

### **4.5.4 TEST PROCEDURE**

- a. Set the RBW = 3 kHz, VBW =10 kHz, Detector = peak.
- b. Sweep time = auto couple, Trace mode = max hold, allow trace to fully stabilize.
- c. Use the peak marker function to determine the maximum power level in any 100 kHz band segment within the fundamental EBW.

### **4.5.5 DEVIATION FROM TEST STANDARD**

No deviation.

### **4.5.6 EUT OPERATING CONDITION**

Same as Item 4.3.6



A D T

#### 4.5.7 TEST RESULTS

Channel	Freq. (MHz)	PSD (dBm/3kHz)	Limit (dBm/3kHz)	PASS /FAIL
<b>802.11b</b>				
1	2412	-14.23	8	PASS
6	2437	-13.38	8	PASS
11	2462	-13.82	8	PASS
<b>802.11g</b>				
1	2412	-19.15	8	PASS
6	2437	-17.08	8	PASS
11	2462	-17.62	8	PASS
<b>802.11n (20MHz)</b>				
1	2412	-16.81	8	PASS
6	2437	-16.07	8	PASS
11	2462	-15.30	8	PASS

## 4.6 CONDUCTED OUT OF BAND EMISSION MEASUREMENT

### 4.6.1 LIMITS OF CONDUCTED OUT OF BAND EMISSION MEASUREMENT

Below  $-20\text{dB}$  of the highest emission level of operating band (in 100kHz Resolution Bandwidth).

### 4.6.2 TEST SETUP

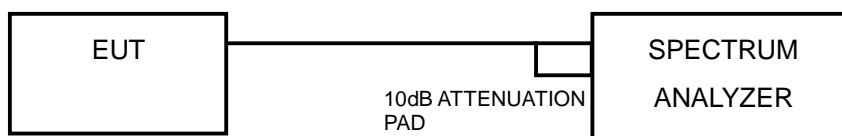

### 4.6.3 TEST INSTRUMENTS

Refer to section 4.1.2 to get information of above instrument.

### 4.6.4 TEST PROCEDURE

#### MEASUREMENT PROCEDURE REF

1. Set the RBW = 100 kHz.
2. Set the VBW  $\geq$  300 kHz.
3. Detector = peak.
4. Sweep time = auto couple.
5. Trace mode = max hold.
6. Allow trace to fully stabilize.
7. Use the peak marker function to determine the maximum power level in any 100 kHz band segment within the fundamental EBW.





A D T

## **MEASUREMENT PROCEDURE OOB**

1. Set RBW = 100 kHz.
2. Set VBW  $\geq$  300 kHz.
3. Set span to encompass the spectrum to be examined.
4. Detector = peak.
5. Trace Mode = max hold.
6. Sweep = auto couple.

### **4.6.5 DEVIATION FROM TEST STANDARD**

No deviation.

### **4.6.6 EUT OPERATING CONDITION**

Same as Item 4.3.6

### **4.6.7 TEST RESULTS**

The spectrum plots are attached on the following pages. D1 line indicates the highest level, and D2 line indicates the 20dB offset below D1. It shows compliance with the requirement.



A D T

### 802.11b

#### CH 1

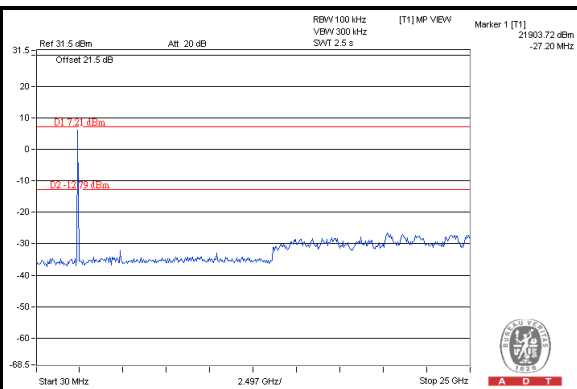
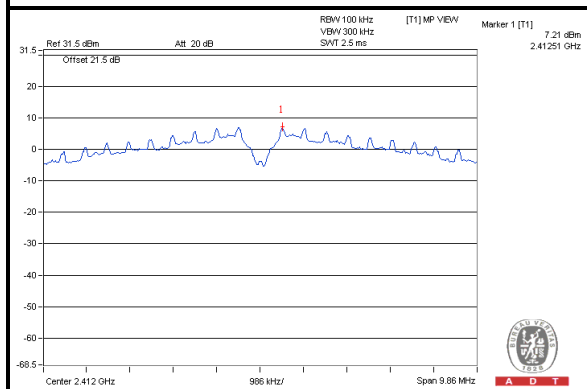

#### CH 6

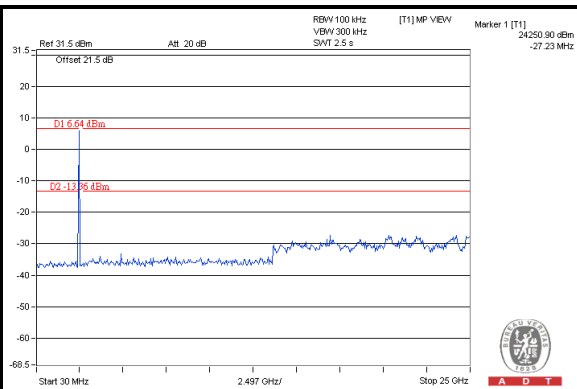
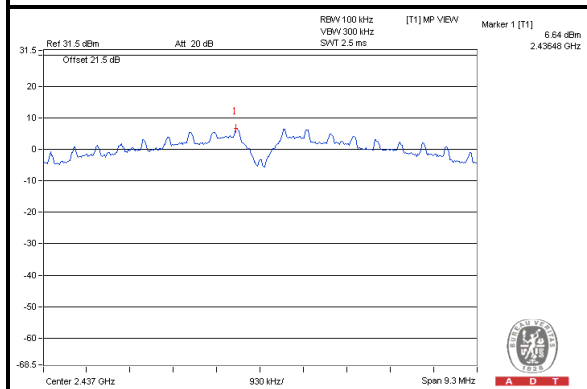

#### CH 11

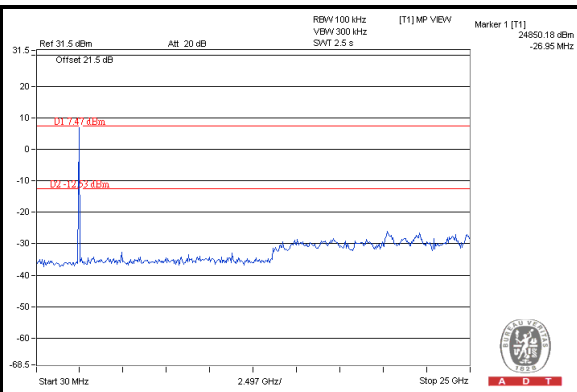
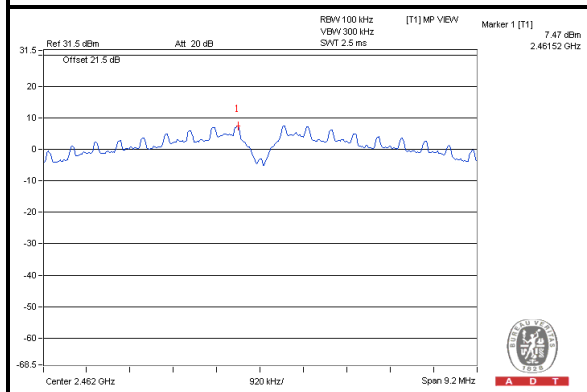



A D T

### 802.11g

#### CH 1

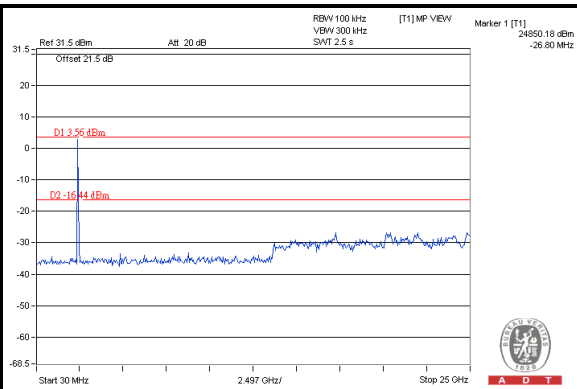
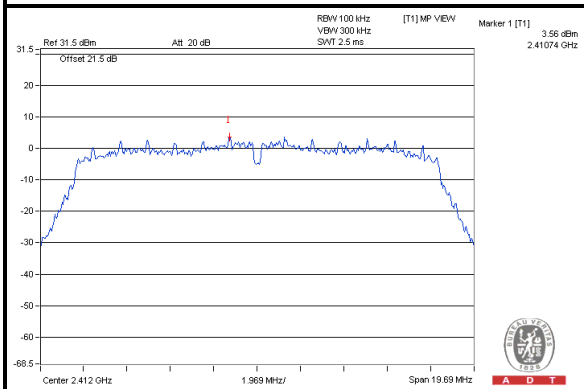

#### CH 6

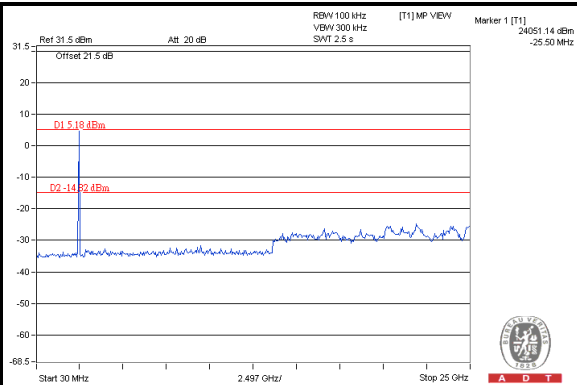
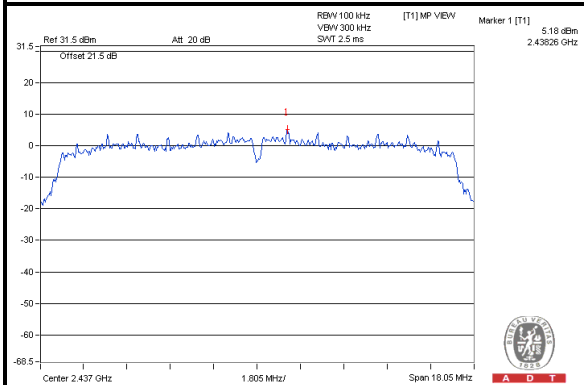

#### CH 11

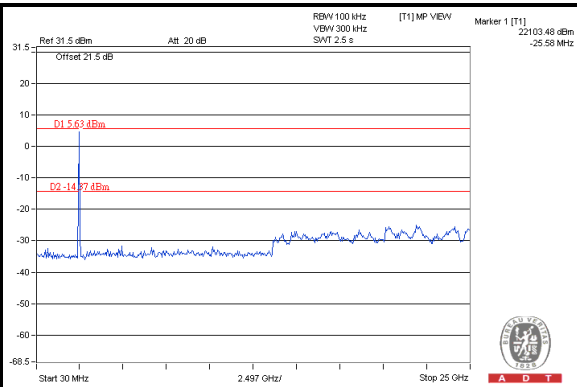
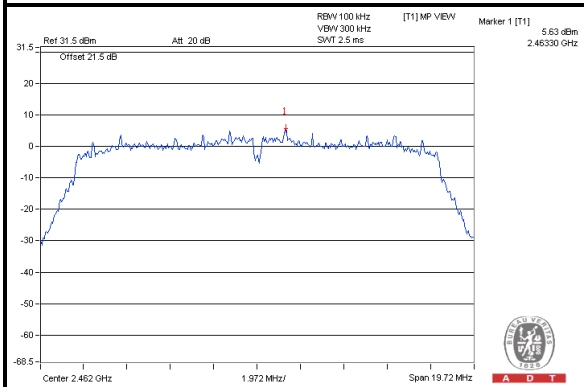



A D T

### 802.11n (20MHz)

#### CH 1

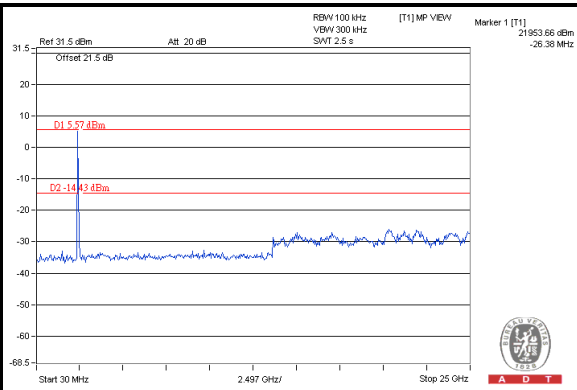
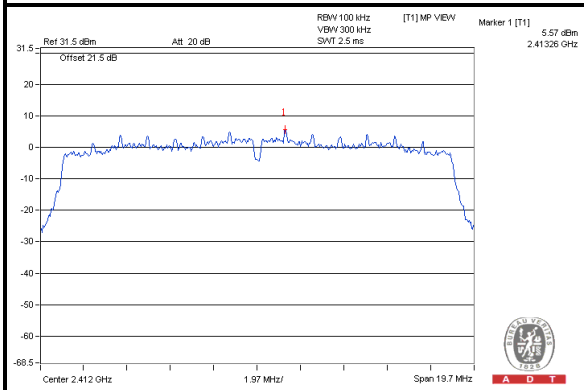

#### CH 6

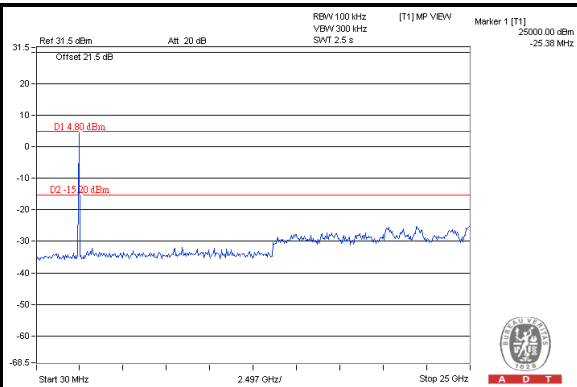
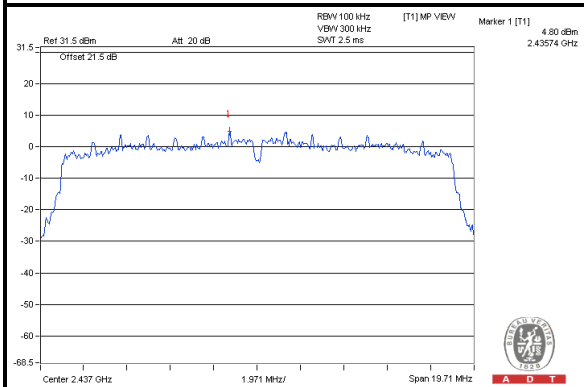

#### CH 11

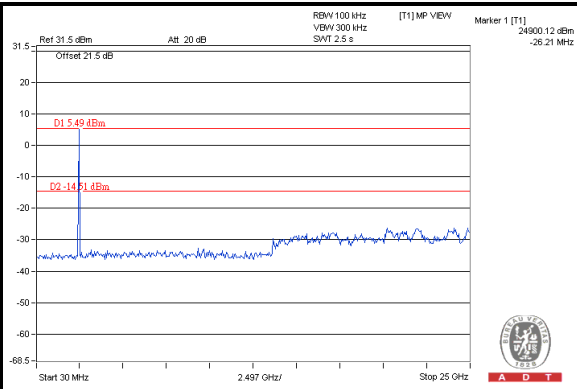
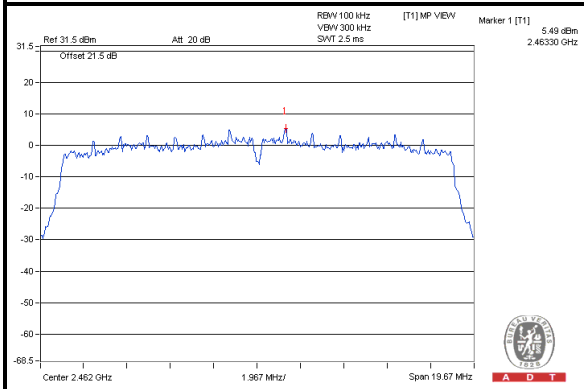



A D T

## 5. PHOTOGRAPHS OF THE TEST CONFIGURATION

Please refer to the attached file (Test Setup Photo).



A D T

## 6. INFORMATION ON THE TESTING LABORATORIES

We, Bureau Veritas Consumer Products Services (H.K.) Ltd., Taoyuan Branch, were founded in 1988 to provide our best service in EMC, Radio, Telecom and Safety consultation. Our laboratories are accredited and approved according to ISO/IEC 17025.

If you have any comments, please feel free to contact us at the following:

**Linko EMC/RF Lab**

Tel: 886-2-26052180

Fax: 886-2-26051924

**Hsin Chu EMC/RF Lab**

Tel: 886-3-5935343

Fax: 886-3-5935342

**Hwa Ya EMC/RF/Safety/Telecom Lab**

Tel: 886-3-3183232

Fax: 886-3-3270892

**Email:** [service.adt@tw.bureauveritas.com](mailto:service.adt@tw.bureauveritas.com)

**Web Site:** [www.bureauveritas-adt.com](http://www.bureauveritas-adt.com)

The address and road map of all our labs can be found in our web site also.



A D T

## **7. APPENDIX A - MODIFICATIONS RECORDERS FOR ENGINEERING CHANGES TO THE EUT BY THE LAB**

No modifications were made to the EUT by the lab during the test.

**---END---**