



FCC TEST REPORT (WLAN 15.407)

REPORT NO.: RF131218D10-1

MODEL NO.: TL10IE1, TL10IE2, TL10Ixy

FCC ID: WL6-TLBC1IE1

RECEIVED: Dec. 18, 2013

TESTED: Jan. 8 ~ 17, 2014

ISSUED: Jan. 27, 2014

APPLICANT: Elitegroup Computer Systems Co., Ltd

ADDRESS: No. 239, Ti Ding Blvd., Sec. 2, Taipei, Taiwan 11493

ISSUED BY: Bureau Veritas Consumer Products Services
(H.K.) Ltd., Taoyuan Branch

LAB ADDRESS: No. 47, 14th Ling, Chia Pau Vil., Lin Kou Dist.,
New Taipei City, Taiwan, R.O.C.

This report should not be used by the client to claim product certification, approval, or endorsement by TAF or any government agencies.



This report is for your exclusive use. Any copying or replication of this report to or for any other person or entity, or use of our name or trademark, is permitted only with our prior written permission. This report sets forth our findings solely with respect to the test samples identified herein. The results set forth in this report are not indicative or representative of the quality or characteristics of the lot from which a test sample was taken or any similar or identical product unless specifically and expressly noted. Our report includes all of the tests requested by you and the results thereof based upon the information that you provided to us. You have 60 days from date of issuance of this report to notify us of any material error or omission caused by our negligence, provided, however, that such notice shall be in writing and shall specifically address the issue you wish to raise. A failure to raise such issue within the prescribed time shall constitute your unqualified acceptance of the completeness of this report, the tests conducted and the correctness of the report contents. Unless specific mention, the uncertainty of measurement has been explicitly taken into account to declare the compliance or non-compliance to the specification.



TABLE OF CONTENTS

RELEASE CONTROL RECORD	4
1. CERTIFICATION	5
2. SUMMARY OF TEST RESULTS	6
2.1 MEASUREMENT UNCERTAINTY	6
3. GENERAL INFORMATION	7
3.1 GENERAL DESCRIPTION OF EUT	7
3.2 DESCRIPTION OF TEST MODES	9
3.2.1 TEST MODE APPLICABILITY AND TESTED CHANNEL DETAIL	10
3.3 DUTY CYCLE OF TEST SIGNAL	12
3.4 DESCRIPTION OF SUPPORT UNITS	15
3.4.1 CONFIGURATION OF SYSTEM UNDER TEST	15
3.5 GENERAL DESCRIPTION OF APPLIED STANDARDS	15
4. TEST TYPES AND RESULTS	17
4.1 RADIATED EMISSION AND BANDEDGE MEASUREMENT	17
4.1.1 LIMITS OF RADIATED EMISSION AND BANDEDGE MEASUREMENT	17
4.1.2 LIMITS OF UNWANTED EMISSION OUT OF THE RESTRICTED BANDS	17
4.1.3 TEST INSTRUMENTS	18
4.1.4 TEST PROCEDURES	19
4.1.5 DEVIATION FROM TEST STANDARD	19
4.1.6 TEST SETUP	20
4.1.7 EUT OPERATING CONDITION	20
4.1.8 TEST RESULTS	21
4.2 CONDUCTED EMISSION MEASUREMENT	47
4.2.1 LIMITS OF CONDUCTED EMISSION MEASUREMENT	47
4.2.2 TEST INSTRUMENTS	47
4.2.3 TEST PROCEDURES	48
4.2.4 DEVIATION FROM TEST STANDARD	48
4.2.5 TEST SETUP	48
4.2.6 EUT OPERATING CONDITIONS	48
4.2.7 TEST RESULTS	49
4.3 PEAK TRANSMIT POWER MEASUREMENT	51
4.3.1 LIMITS OF PEAK TRANSMIT POWER MEASUREMENT	51
4.3.2 TEST SETUP	51
4.3.3 TEST INSTRUMENTS	52
4.3.4 TEST PROCEDURE	52
4.3.5 DEVIATION FROM TEST STANDARD	52
4.3.6 EUT OPERATING CONDITIONS	52
4.3.7 TEST RESULTS	53
4.4 PEAK POWER SPECTRAL DENSITY MEASUREMENT	58
4.4.1 LIMITS OF PEAK POWER SPECTRAL DENSITY MEASUREMENT	58
4.4.2 TEST SETUP	58
4.4.3 TEST INSTRUMENTS	58
4.4.4 TEST PROCEDURES	58
4.4.5 DEVIATION FROM TEST STANDARD	58



A D T

4.4.6	EUT OPERATING CONDITIONS.....	58
4.4.7	TEST RESULTS.....	59
4.5	PEAK POWER EXCURSION MEASUREMENT.....	61
4.5.1	LIMITS OF PEAK POWER EXCURSION MEASUREMENT	61
4.5.2	TEST SETUP	61
4.5.3	TEST INSTRUMENTS	61
4.5.4	TEST PROCEDURE	61
4.5.5	DEVIATION FROM TEST STANDARD	61
4.5.6	EUT OPERATING CONDITIONS.....	61
4.5.7	TEST RESULTS.....	62
4.6	FREQUENCY STABILITY	63
4.6.1	LIMITS OF FREQUENCY STABILITY MEASUREMENT	63
4.6.2	TEST SETUP	63
4.6.3	TEST INSTRUMENTS	63
4.6.4	TEST PROCEDURE	64
4.6.5	DEVIATION FROM TEST STANDARD	64
4.6.6	EUT OPERATING CONDITION	64
4.6.7	TEST RESULTS.....	65
5.	PHOTOGRAPHS OF THE TEST CONFIGURATION	66
6.	INFORMATION ON THE TESTING LABORATORIES.....	67
7.	APPENDIX A - MODIFICATIONS RECORDERS FOR ENGINEERING CHANGES TO THE EUT BY THE LAB.....	68



A D T

RELEASE CONTROL RECORD

ISSUE NO.	REASON FOR CHANGE	DATE ISSUED
RF131218D10-1	Original release	Jan. 27, 2014



1. CERTIFICATION

PRODUCT: Wireless Motherboard

BRAND NAME: ECS ELITEGROUP

MODEL: TL10IE1, TL10IE2, TL10lxy

(x=0~9, A~Z or blank or "-";y=0~9, A~Z or blank or "-")

APPLICANT: Elitegroup Computer Systems Co., Ltd

TESTED: Jan. 8 ~ 17, 2014

TEST SAMPLE: ENGINEERING SAMPLE

STANDARDS: FCC Part 15, Subpart E (Section 15.407)

ANSI C63.10-2009

The above equipment (Model: TL10IE2) has been tested by **Bureau Veritas Consumer Products Services (H.K.) Ltd., Taoyuan Branch**, and found compliance with the requirement of the above standards. The test record, data evaluation & Equipment Under Test (EUT) configurations represented herein are true and accurate accounts of the measurements of the sample's EMC characteristics under the conditions specified in this report.

PREPARED BY : Annie Chang , **DATE:** Jan. 27, 2014
(Annie Chang / Supervisor)

APPROVED BY : Rex Lai , **DATE:** Jan. 27, 2014
(Rex Lai / Assistant Manager)

2. SUMMARY OF TEST RESULTS

The EUT has been tested according to the following specifications:

APPLIED STANDARD: FCC PART 15, SUBPART E (SECTION 15.407)			
STANDARD SECTION	TEST TYPE	RESULT	REMARK
15.407(b)(6)	AC Power Conducted Emission	PASS	Meet the requirement of limit. Minimum passing margin is -24.07dB at 0.16562MHz.
15.407(b/1/2/3) (b)(6)	Radiated Emissions	PASS	Meet the requirement of limit. Minimum passing margin is -7.0dB at 301.71MHz.
15.407(a/1/2)	Max Average Transmit Power	PASS	Meet the requirement of limit.
15.407(a)(6)	Peak Power Excursion	PASS	Meet the requirement of limit.
15.407(a/1/2)	Peak Power Spectral Density	PASS	Meet the requirement of limit.
15.407(g)	Frequency Stability	PASS	Meet the requirement of limit.
15.203	Antenna Requirement	PASS	No antenna connector is used.

2.1 MEASUREMENT UNCERTAINTY

Where relevant, the following measurement uncertainty levels have been estimated for tests performed on the EUT as specified in CISPR 16-4-2:

MEASUREMENT	FREQUENCY	UNCERTAINTY
Conducted emissions	150kHz~30MHz	2.41 dB
Radiated emissions	30MHz ~ 1GHz	4.30 dB
	Above 1GHz	3.36 dB

This uncertainty represents an expanded uncertainty expressed at approximately the 95% confidence level using a coverage factor of $k = 2$.

3. GENERAL INFORMATION

3.1 GENERAL DESCRIPTION OF EUT

EUT	Wireless Motherboard
MODEL NO.	TL10IE1, TL10IE2, TL10lxy
POWER SUPPLY	12Vdc from AC adapter, 3.7V or 3.8Vdc from Battery
MODULATION TYPE	64QAM, 16QAM, QPSK, BPSK
MODULATION TECHNOLOGY	OFDM
TRANSFER RATE	802.11a: 54.0/ 48.0/ 36.0/ 24.0/ 18.0/ 12.0/ 9.0/ 6.0Mbps 802.11n: up to 72Mbps
OPERATING FREQUENCY	5180 ~ 5240MHz, 5260 ~ 5320MHz & 5500 ~ 5700MHz
NUMBER OF CHANNEL	5180 ~ 5240MHz: 4 for 802.11a, 802.11n (20MHz) 2 for 802.11n (40MHz) 5260 ~ 5320MHz: 4 for 802.11a, 802.11n (20MHz) 2 for 802.11n (40MHz) 5500 ~ 5700MHz: 8 for 802.11a, 802.11n (20MHz) 3 for 802.11n (40MHz)
OUTPUT POWER	19.7mW for 5180 ~ 5240MHz 20.6mW for 5260 ~ 5320MHz 19.3mW for 5500 ~ 5700MHz
ANTENNA TYPE	PCB antenna with 1.56dBi gain (Main) PCB antenna with 1.66dBi gain (Aux.)
ANTENNA CONNECTOR	N/A
DATA CABLE	N/A
I/O PORTS	Refer to user's manual
ACCESSORY DEVICES	Refer to Note as below

NOTE:

1. The EUT is a Wireless Motherboard with a 802.11abgn & Bluetooth Combo module.
2. The "x & y" in the model could be defined as 0~9, A~Z or blank for marketing differentiation. During the test, model: **TL10IE2** was selected as the representative one and therefore only its test data was recorded in this report.

3. The EUT incorporates a SISO function. Physically, the EUT provides one completed transmitter and one receiver.

Modulation Mode	Tx Function
802.11b	1TX
802.11g	1TX
802.11a	1TX
802.11n (20MHz)	2TX
802.11n (40MHz)	2TX

4. The EUT consumes power from an AC adapter or battery, as follows:

Item	Brand	Model No.	Spec.
Adapter 1	APD	WA-24R12FU	AC I/P: 100-240Vac, 50-60Hz, 0.8A Max. DC O/P: 12V, 2A AC 2 Pin. Non-shielded DC cable (1.5m)
Adapter 2	APD	WA-24K12FU	AC I/P: 100-240Vac, 50-60Hz, 0.8A Max DC O/P: 12V, 2A AC 2 Pin. Non-shielded DC cable (1.5m)
Battery 1	SWD	LI8400	31W, 3.8V, 8400mAh, 2 CELLS (1S2P)
Battery 2	GLW	LI8400	31W, 3.8V, 8400mAh, 2 CELLS (1S2P)
Battery 3	GLW	LI7700	28W, 3.7V, 7700mAh, 2 CELLS (1S2P)
Battery 4	SWD	LI7600	28W, 3.7V, 7700mAh, 2 CELLS (1S2P)

After pre-tested, the worst emission level was found when the EUT was tested under **Adapter 1 with Battery 1** mode, therefore, only its test data was recorded in this report.

5. For Spurious Emissions test, following modes were pre-tested:
- ◆ EUT + Adapter
 - ◆ EUT only

The worst emission level was found when the EUT was tested under **EUT + Adapter** mode, therefore, only its test data was recorded in this report.

6. The above EUT information is declared by manufacturer and for more detailed features description, please refer to the manufacturer's specifications or user's manual.

3.2 DESCRIPTION OF TEST MODES

FOR 5180 ~ 5240MHz

4 channels are provided for 802.11a, 802.11n (20MHz):

CHANNEL	FREQUENCY	CHANNEL	FREQUENCY
36	5180 MHz	44	5220 MHz
40	5200 MHz	48	5240 MHz

2 channels are provided for 802.11n (40MHz):

CHANNEL	FREQUENCY	CHANNEL	FREQUENCY
38	5190 MHz	46	5230 MHz

FOR 5260 ~ 5320MHz

4 channels are provided for 802.11a, 802.11n (20MHz):

CHANNEL	FREQUENCY	CHANNEL	FREQUENCY
52	5260 MHz	60	5300 MHz
56	5280 MHz	64	5320 MHz

2 channels are provided for 802.11n (40MHz):

CHANNEL	FREQUENCY	CHANNEL	FREQUENCY
54	5270 MHz	62	5310 MHz

FOR 5500 ~ 5700MHz

8 channels are provided for 802.11a, 802.11n (20MHz):

CHANNEL	FREQUENCY	CHANNEL	FREQUENCY
100	5500 MHz	116	5580 MHz
104	5520 MHz	132	5660 MHz
108	5540 MHz	136	5680 MHz
112	5560 MHz	140	5700 MHz

3 channels are provided for 802.11n (40MHz):

CHANNEL	FREQUENCY	CHANNEL	FREQUENCY
102	5510 MHz	134	5670 MHz
110	5550 MHz		

3.2.1 TEST MODE APPLICABILITY AND TESTED CHANNEL DETAIL

EUT CONFIGURE MODE	APPLICABLE TO				DESCRIPTION
	RE \geq 1G	RE<1G	PLC	APCM	
-	√	√	√	√	-

Where **RE \geq 1G**: Radiated Emission above 1GHz **RE<1G**: Radiated Emission below 1GHz
PLC: Power Line Conducted Emission **APCM**: Antenna Port Conducted Measurement

NOTE: The EUT had been pre-tested on the positioned of 3 axis. The worst case was found when positioned on **X-plane**.

RADIATED EMISSION TEST (ABOVE 1GHz):

- Pre-Scan has been conducted to determine the worst-case mode from all possible combinations between available modulations, data rates and antenna ports (if EUT with antenna diversity architecture).
- Following channel(s) was (were) selected for the final test as listed below.

MODE	FREQ. BAND (MHz)	AVAILABLE CHANNEL	TESTED CHANNEL	MODULATION TECHNOLOGY	MODULATION TYPE	DATA RATE (Mbps)
802.11a	5180-5240	36 to 48	36, 40, 48	OFDM	BPSK	6.0
802.11n (20MHz)		36 to 48	36, 40, 48	OFDM	BPSK	13.0
802.11n (40MHz)		38 to 46	38, 46	OFDM	BPSK	27.0
802.11a	5260-5320	52 to 64	52, 60, 64	OFDM	BPSK	6.0
802.11n (20MHz)		52 to 64	52, 60, 64	OFDM	BPSK	13.0
802.11n (40MHz)		54 to 62	54, 62	OFDM	BPSK	27.0
802.11a	5500-5700	100 to 140	100, 116, 140	OFDM	BPSK	6.0
802.11n (20MHz)		100 to 140	100, 116, 140	OFDM	BPSK	13.0
802.11n (40MHz)		102 to 134	102, 110, 134	OFDM	BPSK	27.0

RADIATED EMISSION TEST (BELOW 1GHz):

- Pre-Scan has been conducted to determine the worst-case mode from all possible combinations between available modulations, data rates and antenna ports (if EUT with antenna diversity architecture).
- Following channel(s) was (were) selected for the final test as listed below.

MODE	FREQ. BAND (MHz)	AVAILABLE CHANNEL	TESTED CHANNEL	MODULATION TECHNOLOGY	MODULATION TYPE	DATA RATE (Mbps)
802.11a	5260-5320	52 to 64	52	OFDM	BPSK	6.0

POWER LINE CONDUCTED EMISSION TEST:

- Pre-Scan has been conducted to determine the worst-case mode from all possible combinations between available modulations, data rates and antenna ports (if EUT with antenna diversity architecture).
- Following channel(s) was (were) selected for the final test as listed below.

MODE	FREQ. BAND (MHz)	AVAILABLE CHANNEL	TESTED CHANNEL	MODULATION TECHNOLOGY	MODULATION TYPE	DATA RATE (Mbps)
802.11a	5260-5320	52 to 64	52	OFDM	BPSK	6.0

ANTENNA PORT CONDUCTED MEASUREMENT:

- This item includes all test value of each mode, but only includes spectrum plot of worst value of each mode.
- Pre-Scan has been conducted to determine the worst-case mode from all possible combinations between available modulations, data rates and antenna ports (if EUT with antenna diversity architecture).
- Following channel(s) was (were) selected for the final test as listed below.

MODE	FREQ. BAND (MHz)	AVAILABLE CHANNEL	TESTED CHANNEL	MODULATION TECHNOLOGY	MODULATION TYPE	DATA RATE (Mbps)
802.11a	5180-5240	36 to 48	36, 40, 48	OFDM	BPSK	6.0
802.11n (20MHz)		36 to 48	36, 40, 48	OFDM	BPSK	13.0
802.11n (40MHz)		38 to 46	38, 46	OFDM	BPSK	27.0
802.11a	5260-5320	52 to 64	52, 60, 64	OFDM	BPSK	6.0
802.11n (20MHz)		52 to 64	52, 60, 64	OFDM	BPSK	13.0
802.11n (40MHz)		54 to 62	54, 62	OFDM	BPSK	27.0
802.11a	5500-5700	100 to 140	100, 116, 140	OFDM	BPSK	6.0
802.11n (20MHz)		100 to 140	100, 116, 140	OFDM	BPSK	13.0
802.11n (40MHz)		102 to 134	102, 110, 134	OFDM	BPSK	27.0

TEST CONDITION:

APPLICABLE TO	ENVIRONMENTAL CONDITIONS	INPUT POWER	TESTED BY
RE≥1G	23deg. C, 17% RH	120Vac, 60Hz	Joey Liu
RE<1G	21deg. C, 75% RH	120Vac, 60Hz	Joey Liu
PLC	23deg. C, 75% RH	120Vac, 60Hz	Joey Liu
APCM	25deg. C, 60%RH	120Vac, 60Hz	Dalen Dai

3.3 DUTY CYCLE OF TEST SIGNAL

Duty factor shall be considered.

802.11a:

BPSK: Duty cycle = $2.062 / 2.174 = 0.948$, Duty factor = $10 * \log(1 / 0.948) = 0.23$

QPSK: Duty cycle = $1.052 / 1.080 = 0.974$, Duty factor = $10 * \log(1 / 0.974) = 0.11$

16QAM: Duty cycle = $0.532 / 0.564 = 0.943$, Duty factor = $10 * \log(1 / 0.943) = 0.25$

64QAM: Duty cycle = $0.276 / 0.306 = 0.902$, Duty factor = $10 * \log(1 / 0.902) = 0.45$

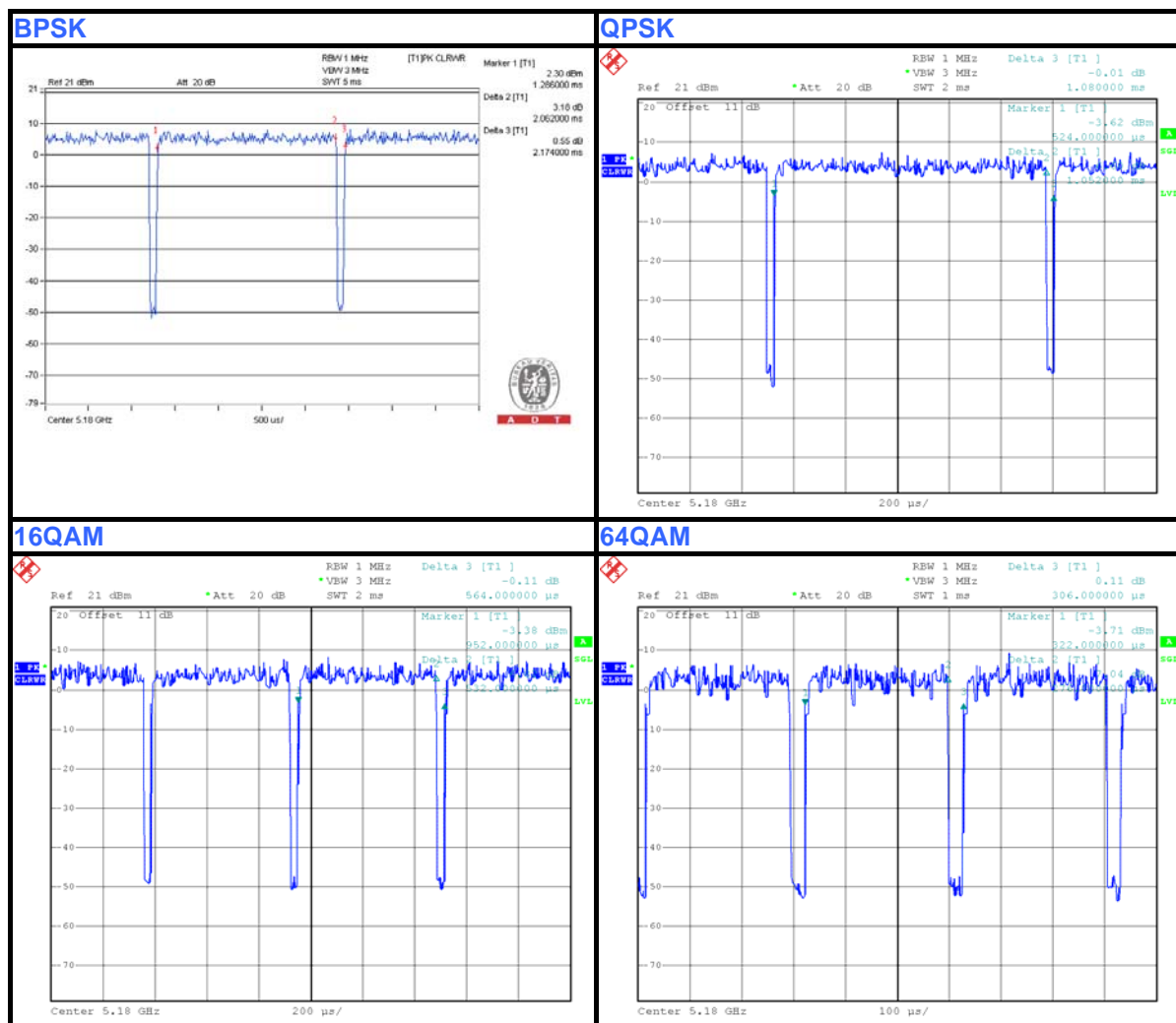



A D T

802.11n (20MHz)

BPSK: Duty cycle = $0.990 / 1.090 = 0.908$, Duty factor = $10 * \log(1 / 0.908) = 0.42$

QPSK: Duty cycle = $0.276 / 0.308 = 0.896$, Duty factor = $10 * \log(1 / 0.896) = 0.48$

16QAM: Duty cycle = $0.198 / 0.228 = 0.868$, Duty factor = $10 * \log(1 / 0.868) = 0.61$

64QAM: Duty cycle = $0.148 / 0.177 = 0.836$, Duty factor = $10 * \log(1 / 0.836) = 0.78$

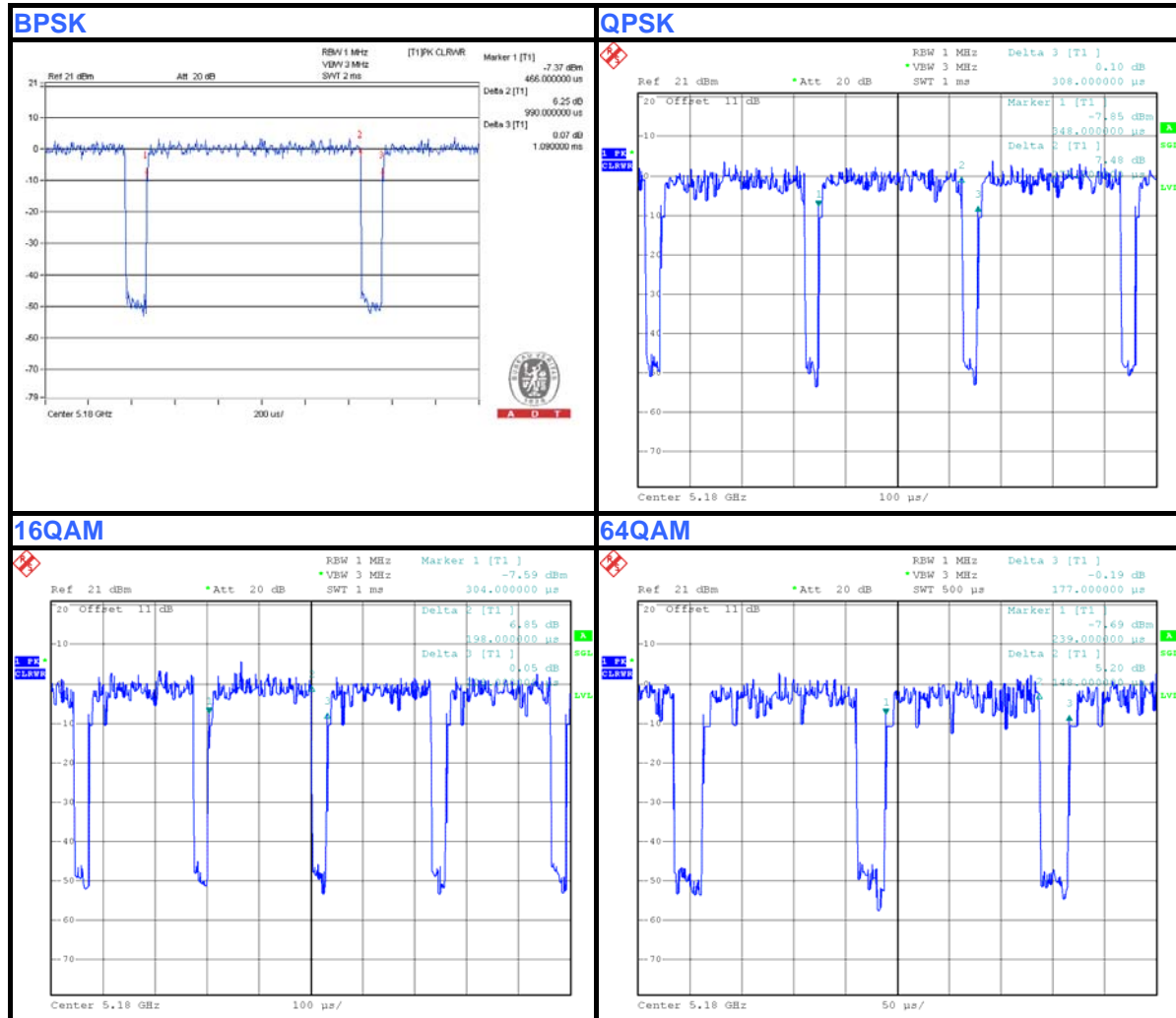



A D T

802.11n (40MHz):

BPSK: Duty cycle = 0.498 / 0.594 = 0.838 , Duty factor = 10 * log(1/ 0.838) = 0.77

QPSK: Duty cycle = 0.192 / 0.220 = 0.873 , Duty factor = 10 * log(1/ 0.873) = 0.59

16QAM: Duty cycle = 0.116 / 0.144 = 0.806 , Duty factor = 10 * log(1/ 0.806) = 0.94

64QAM: Duty cycle = 0.119 / 0.161 = 0.739 , Duty factor = 10 * log(1/ 0.739) = 1.31

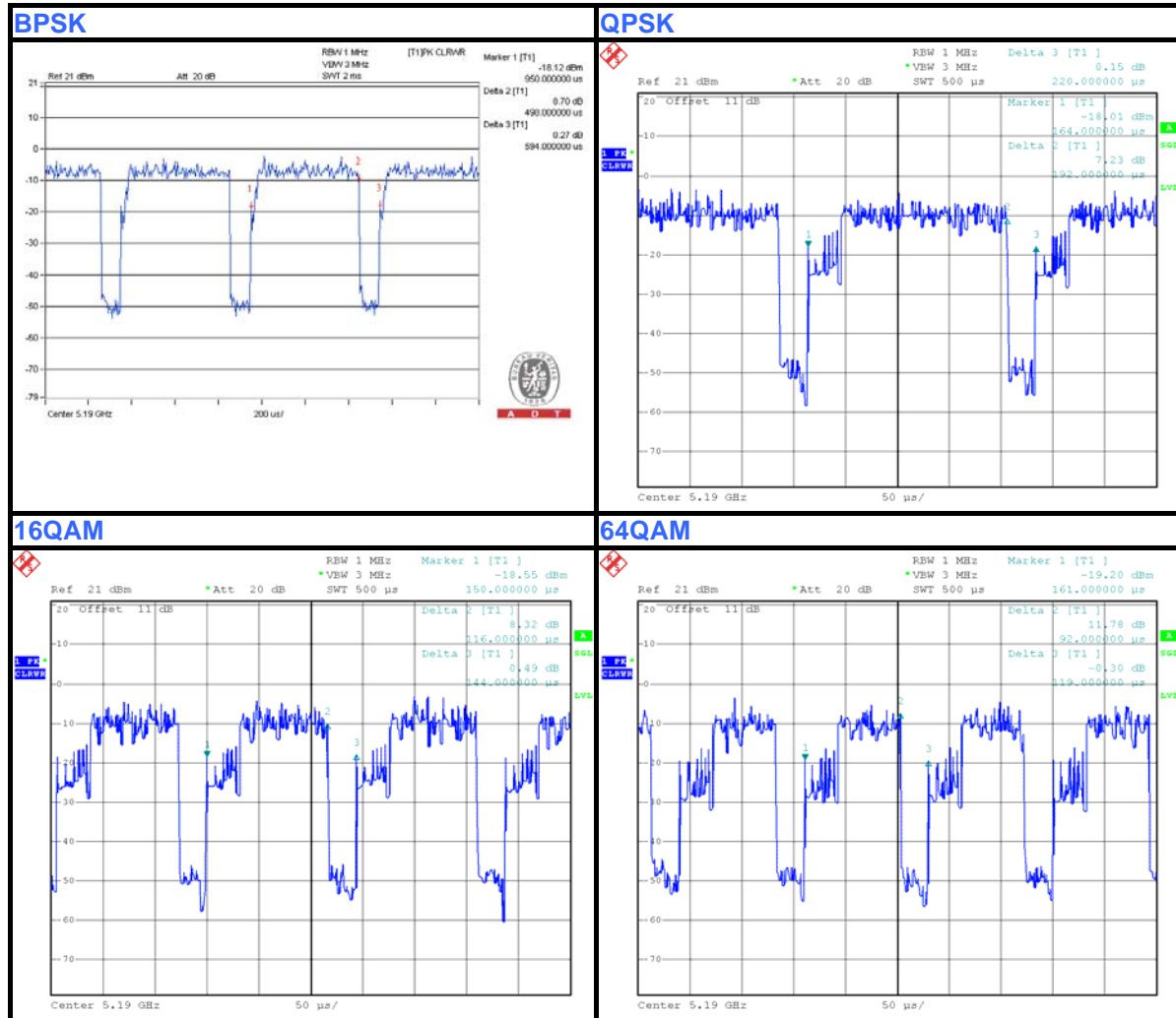

3.4 DESCRIPTION OF SUPPORT UNITS

The EUT has been tested as an independent unit together without other necessary accessories or support units.

3.4.1 CONFIGURATION OF SYSTEM UNDER TEST

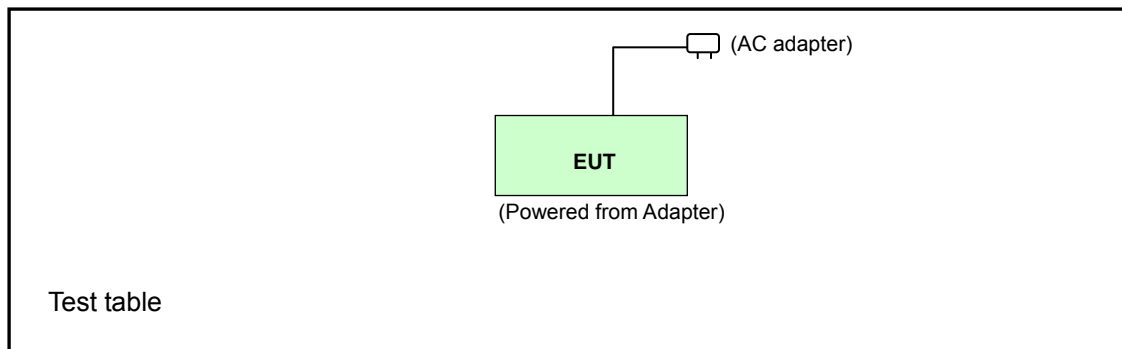



3.5 GENERAL DESCRIPTION OF APPLIED STANDARDS

The EUT is a RF Product. According to the specifications of the manufacturer, it must comply with the requirements of the following standards:

FCC Part 15, Subpart E (15.407)

789033 D01 General UNII Test Procedures v01 r03

662911 D01 Multiple Transmitter Output v02

ANSI C63.10-2009

All test items have been performed and recorded as per the above standards.

4. TEST TYPES AND RESULTS

4.1 RADIATED EMISSION AND BANDEDGE MEASUREMENT

4.1.1 LIMITS OF RADIATED EMISSION AND BANDEDGE MEASUREMENT

Radiated emissions which fall in the restricted bands must comply with the radiated emission limits specified as below table:

FREQUENCIES (MHz)	FIELD STRENGTH (microvolts/meter)	MEASUREMENT DISTANCE (meters)
0.009 ~ 0.490	2400/F(kHz)	300
0.490 ~ 1.705	24000/F(kHz)	30
1.705 ~ 30.0	30	30
30 ~ 88	100	3
88 ~ 216	150	3
216 ~ 960	200	3
Above 960	500	3

NOTE:

1. The lower limit shall apply at the transition frequencies.
2. Emission level (dBuV/m) = 20 log Emission level (uV/m).
3. For frequencies above 1000MHz, the field strength limits are based on average detector, however, the peak field strength of any emission shall not exceed the maximum permitted average limits, specified above by more than 20dB under any condition of modulation.

4.1.2 LIMITS OF UNWANTED EMISSION OUT OF THE RESTRICTED BANDS

APPLICABLE TO	LIMIT	
√	FIELD STRENGTH AT 3m (dBμV/m)	
	PK	AV
	74	54
	EIRP LIMIT (dBm)	EQUIVALENT FIELD STRENGTH AT 3m (dBμV/m)
	PK	PK
	-27	68.3

NOTE: The following formula is used to convert the equipment isotropic radiated power (eirp) to field strength:

$$E = \frac{1000000\sqrt{30P}}{3} \mu\text{V/m, where P is the eirp (Watts).}$$



4.1.3 TEST INSTRUMENTS

DESCRIPTION & MANUFACTURER	MODEL NO.	SERIAL NO.	CALIBRATED DATE	CALIBRATED UNTIL
HP Preamplifier	8447D	2432A03504	Feb. 26, 2013	Feb. 25, 2014
HP Preamplifier	8449B	3008A01201	Feb. 26, 2013	Feb. 25, 2014
Agilent TEST RECEIVER	N9038A	MY51210129	Jan. 18, 2014	Jan. 17, 2015
Schwarzbeck Antenna	VULB 9168	137	Mar. 20, 2013	Mar. 19, 2014
Schwarzbeck Antenna	VHBA 9123	480	May 29, 2013	May 28, 2014
ADT. Turn Table	TT100	0306	NA	NA
ADT. Tower	AT100	0306	NA	NA
Software	ADT_Radiated_V 7.6.15.9.2	NA	NA	NA
SUHNER RF cable	SF102	CABLE-CH6	Aug. 16, 2013	Aug. 15, 2014
Loop Antenna R & S	HFH2-Z2	100070	Jan. 31, 2012	Jan. 30, 2014
Schwarzbeck Horn Antenna	BBHA 9120-D1	D130	May 13, 2013	May 12, 2014
Highpass filter Wainwright Instruments	WHK 3.1/18G-10SS	SN 8	NA	NA
ROHDE & SCHWARZ Spectrum Analyzer	FSP 40	100036	May. 17, 2013	May. 16, 2014
Anritsu Power Sensor	MA2411B	0738404	Apr. 24, 2013	Apr. 23, 2014
Anritsu Power Meter	ML2495A	0842014	Apr. 25, 2013	Apr. 24, 2014

- NOTE:**
1. The calibration interval of the above test instruments is 12/24 months. And the calibrations are traceable to NML/ROC and NIST/USA.
 2. The horn antenna and HP preamplifier (model: 8449B) are used only for the measurement of emission frequency above 1GHz if tested.
 3. The test was performed in Chamber No. 6.
 4. The Industry Canada Reference No. IC 7450E-6.
 5. The FCC Site Registration No. is 447212.

4.1.4 TEST PROCEDURES

- a. The EUT was placed on the top of a rotating table 0.8 meters above the ground at a 3 meter semi-anechoic chamber. The table was rotated 360 degrees to determine the position of the highest radiation.
- b. The EUT was set 3 meters away from the interference-receiving antenna, which was mounted on the top of a variable-height antenna tower.
- c. The antenna is a broadband antenna, and its height is varied from one meter to four meters above the ground to determine the maximum value of the field strength. Both horizontal and vertical polarizations of the antenna are set to make the measurement.
- d. For each suspected emission, the EUT was arranged to its worst case and then the antenna was tuned to heights from 1 meter to 4 meters and the rotatable table was turned from 0 degrees to 360 degrees to find the maximum reading.
- e. The test-receiver system was set to Peak Detect Function and Specified Bandwidth with Maximum Hold Mode.
- f. If the emission level of the EUT in peak mode was 10dB lower than the limit specified, then testing could be stopped and the peak values of the EUT would be reported. Otherwise the emissions that did not have 10dB margin would be re-tested one by one using peak, quasi-peak or average method as specified and then reported in a data sheet.

NOTE:

1. The resolution bandwidth and video bandwidth of test receiver/spectrum analyzer is 120kHz for Peak detection (PK) and Quasi-peak detection (QP) at frequency below 1GHz.
2. The resolution bandwidth of test receiver/spectrum analyzer is 1MHz and video bandwidth is 3MHz for Peak detection at frequency above 1GHz.
3. The resolution bandwidth of test receiver/spectrum analyzer is 1MHz and the video bandwidth is 1kHz for Average detection (AV) at frequency above 1GHz.
4. All modes of operation were investigated and the worst-case emissions are reported.

4.1.5 DEVIATION FROM TEST STANDARD

No deviation.

4.1.6 TEST SETUP

Frequency range 30MHz~1GHz

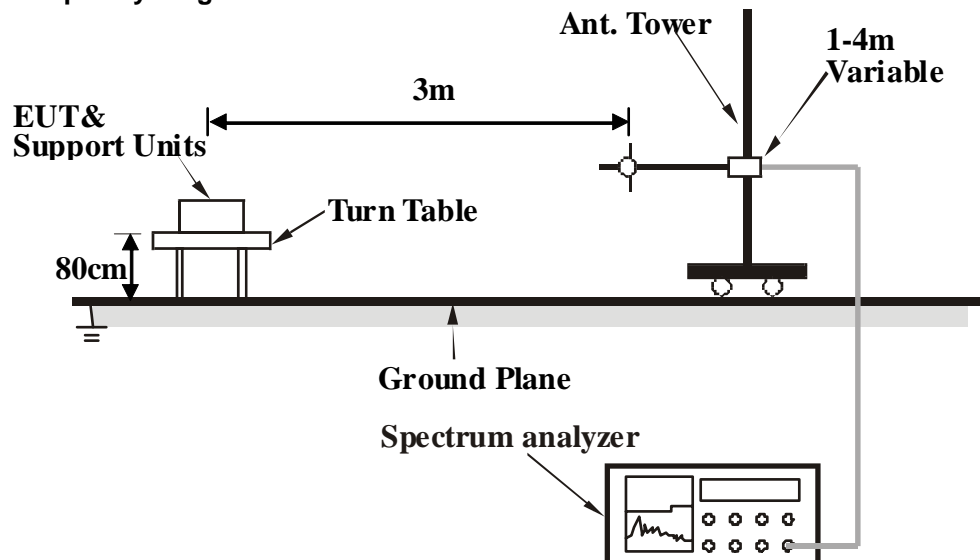

Frequency range above 1GHz

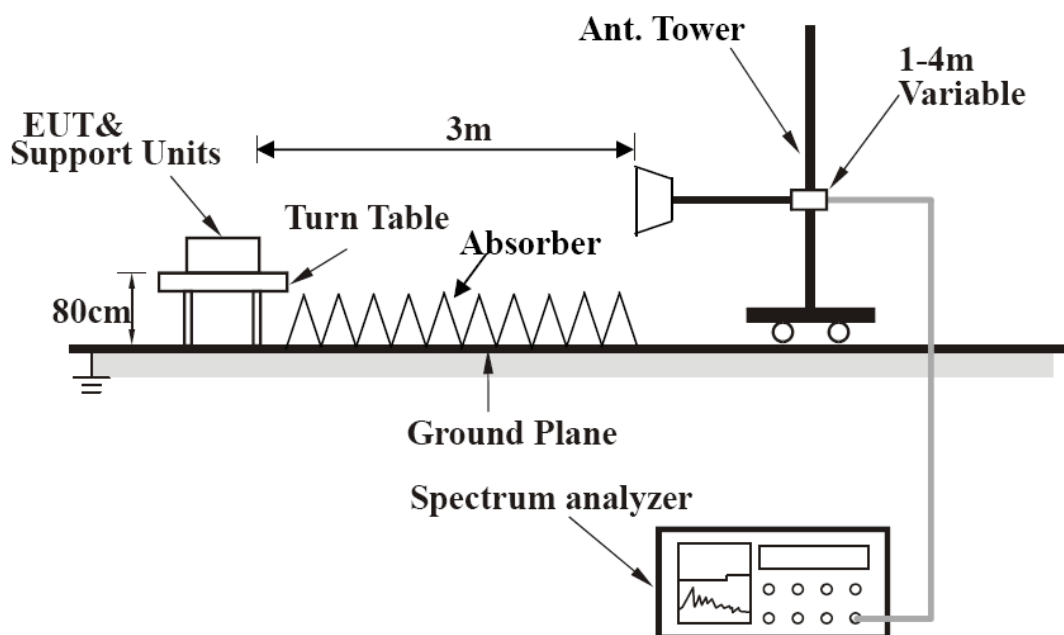

For the actual test configuration, please refer to the attached file (Test Setup Photo).

4.1.7 EUT OPERATING CONDITION

- Connected the EUT to AC adapter.
- Set the EUT under transmitting condition.

4.1.8 TEST RESULTS

ABOVE 1GHz DATA

802.11a

CHANNEL	TX Channel 36	DETECTOR FUNCTION	Peak (PK)
FREQUENCY RANGE	1GHz ~ 40GHz		Average (AV)

ANTENNA POLARITY & TEST DISTANCE: HORIZONTAL AT 3 M								
NO.	FREQ. (MHz)	EMISSION LEVEL (dBuV/m)	LIMIT (dBuV/m)	MARGIN (dB)	ANTENNA HEIGHT (m)	TABLE ANGLE (Degree)	RAW VALUE (dBuV)	CORRECTION FACTOR (dB/m)
1	5150.00	53.7 PK	74.0	-20.3	1.00 H	181	49.68	4.05
2	5150.00	41.5 AV	54.0	-12.5	1.00 H	181	37.48	4.05
3	*5180.00	94.7 PK			1.00 H	181	90.55	4.14
4	*5180.00	85.3 AV			1.00 H	181	81.18	4.14
5	10360.00	51.7 PK	74.0	-22.3	1.00 H	181	37.01	14.73
6	10360.00	41.3 AV	54.0	-12.7	1.00 H	181	26.54	14.73
ANTENNA POLARITY & TEST DISTANCE: VERTICAL AT 3 M								
NO.	FREQ. (MHz)	EMISSION LEVEL (dBuV/m)	LIMIT (dBuV/m)	MARGIN (dB)	ANTENNA HEIGHT (m)	TABLE ANGLE (Degree)	RAW VALUE (dBuV)	CORRECTION FACTOR (dB/m)
1	5150.00	58.6 PK	74.0	-15.4	1.00 V	269	54.58	4.05
2	5150.00	44.8 AV	54.0	-9.2	1.00 V	269	40.79	4.05
3	*5180.00	99.3 PK			1.00 V	269	95.14	4.14
4	*5180.00	89.8 AV			1.00 V	269	85.68	4.14
5	10360.00	53.1 PK	74.0	-20.9	1.00 V	270	38.41	14.73
6	10360.00	41.3 AV	54.0	-12.7	1.00 V	270	26.53	14.73

REMARKS:

1. Emission Level(dBuV/m) = Raw Value(dBuV) + Correction Factor(dB/m)
2. Correction Factor(dB/m) = Antenna Factor(dB/m) + Cable Factor(dB) – Pre-Amplifier Factor(dB)
3. The other emission levels were very low against the limit.
4. Margin value = Emission Level – Limit value
5. " * ": Fundamental frequency.

CHANNEL	TX Channel 40	DETECTOR FUNCTION	Peak (PK)
FREQUENCY RANGE	1GHz ~ 40GHz		Average (AV)

ANTENNA POLARITY & TEST DISTANCE: HORIZONTAL AT 3 M								
NO.	FREQ. (MHz)	EMISSION LEVEL (dBuV/m)	LIMIT (dBuV/m)	MARGIN (dB)	ANTENNA HEIGHT (m)	TABLE ANGLE (Degree)	RAW VALUE (dBuV)	CORRECTION FACTOR (dB/m)
1	*5200.00	95.7 PK			1.00 H	181	91.54	4.19
2	*5200.00	86.3 AV			1.00 H	181	82.14	4.19
3	10400.00	52.4 PK	74.0	-21.6	1.00 H	181	37.25	15.12
4	10400.00	40.6 AV	54.0	-13.4	1.00 H	181	25.49	15.12
ANTENNA POLARITY & TEST DISTANCE: VERTICAL AT 3 M								
NO.	FREQ. (MHz)	EMISSION LEVEL (dBuV/m)	LIMIT (dBuV/m)	MARGIN (dB)	ANTENNA HEIGHT (m)	TABLE ANGLE (Degree)	RAW VALUE (dBuV)	CORRECTION FACTOR (dB/m)
1	*5200.00	98.7 PK			1.00 V	270	94.54	4.19
2	*5200.00	89.2 AV			1.00 V	270	85.05	4.19
3	10400.00	53.1 PK	74.0	-20.9	1.00 V	270	37.96	15.12
4	10400.00	40.8 AV	54.0	-13.2	1.00 V	270	25.71	15.12

REMARKS:

1. Emission Level(dBuV/m) = Raw Value(dBuV) + Correction Factor(dB/m)
2. Correction Factor(dB/m) = Antenna Factor(dB/m) + Cable Factor(dB) – Pre-Amplifier Factor(dB)
3. The other emission levels were very low against the limit.
4. Margin value = Emission Level – Limit value
5. " * ": Fundamental frequency.



A D T

CHANNEL	TX Channel 48	DETECTOR FUNCTION	Peak (PK)
FREQUENCY RANGE	1GHz ~ 40GHz		Average (AV)

ANTENNA POLARITY & TEST DISTANCE: HORIZONTAL AT 3 M

NO.	FREQ. (MHz)	EMISSION LEVEL (dBuV/m)	LIMIT (dBuV/m)	MARGIN (dB)	ANTENNA HEIGHT (m)	TABLE ANGLE (Degree)	RAW VALUE (dBuV)	CORRECTION FACTOR (dB/m)
1	*5240.00	94.5 PK			1.00 H	12	90.13	4.35
2	*5240.00	84.6 AV			1.00 H	12	80.24	4.35
3	10480.00	52.4 PK	74.0	-21.7	1.00 H	12	37.43	14.92
4	10480.00	40.2 AV	54.0	-13.8	1.00 H	12	25.32	14.92

ANTENNA POLARITY & TEST DISTANCE: VERTICAL AT 3 M

NO.	FREQ. (MHz)	EMISSION LEVEL (dBuV/m)	LIMIT (dBuV/m)	MARGIN (dB)	ANTENNA HEIGHT (m)	TABLE ANGLE (Degree)	RAW VALUE (dBuV)	CORRECTION FACTOR (dB/m)
1	*5240.00	101.3 PK			1.00 V	5	96.91	4.35
2	*5240.00	94.2 AV			1.00 V	5	89.88	4.35
3	10480.00	53.4 PK	74.0	-20.6	1.00 V	0	38.49	14.92
4	10480.00	41.0 AV	54.0	-13.0	1.00 V	0	26.12	14.92

REMARKS:

1. Emission Level(dBuV/m) = Raw Value(dBuV) + Correction Factor(dB/m)
2. Correction Factor(dB/m) = Antenna Factor(dB/m) + Cable Factor(dB) – Pre-Amplifier Factor(dB)
3. The other emission levels were very low against the limit.
4. Margin value = Emission Level – Limit value
5. " * ": Fundamental frequency.

CHANNEL	TX Channel 52	DETECTOR FUNCTION	Peak (PK)
FREQUENCY RANGE	1GHz ~ 40GHz		Average (AV)

ANTENNA POLARITY & TEST DISTANCE: HORIZONTAL AT 3 M								
NO.	FREQ. (MHz)	EMISSION LEVEL (dBuV/m)	LIMIT (dBuV/m)	MARGIN (dB)	ANTENNA HEIGHT (m)	TABLE ANGLE (Degree)	RAW VALUE (dBuV)	CORRECTION FACTOR (dB/m)
1	*5260.00	94.3 PK			1.00 H	198	89.88	4.42
2	*5260.00	85.1 AV			1.00 H	198	80.71	4.42
3	10520.00	56.1 PK	74.0	-17.9	1.00 H	198	41.14	14.98
4	10520.00	43.1 AV	54.0	-10.9	1.00 H	198	28.08	14.98
ANTENNA POLARITY & TEST DISTANCE: VERTICAL AT 3 M								
NO.	FREQ. (MHz)	EMISSION LEVEL (dBuV/m)	LIMIT (dBuV/m)	MARGIN (dB)	ANTENNA HEIGHT (m)	TABLE ANGLE (Degree)	RAW VALUE (dBuV)	CORRECTION FACTOR (dB/m)
1	*5260.00	100.9 PK			1.00 V	5	96.46	4.42
2	*5260.00	91.3 AV			1.00 V	5	86.91	4.42
3	10520.00	54.4 PK	74.0	-19.6	1.00 V	5	39.46	14.98
4	10520.00	42.0 AV	54.0	-12.0	1.00 V	5	27.01	14.98

REMARKS:

1. Emission Level(dBuV/m) = Raw Value(dBuV) + Correction Factor(dB/m)
2. Correction Factor(dB/m) = Antenna Factor(dB/m) + Cable Factor(dB) – Pre-Amplifier Factor(dB)
3. The other emission levels were very low against the limit.
4. Margin value = Emission Level – Limit value
5. " * ": Fundamental frequency.

CHANNEL	TX Channel 60	DETECTOR FUNCTION	Peak (PK)
FREQUENCY RANGE	1GHz ~ 40GHz		Average (AV)

ANTENNA POLARITY & TEST DISTANCE: HORIZONTAL AT 3 M								
NO.	FREQ. (MHz)	EMISSION LEVEL (dBuV/m)	LIMIT (dBuV/m)	MARGIN (dB)	ANTENNA HEIGHT (m)	TABLE ANGLE (Degree)	RAW VALUE (dBuV)	CORRECTION FACTOR (dB/m)
1	*5300.00	95.2 PK			1.00 H	179	90.59	4.58
2	*5300.00	85.9 AV			1.00 H	179	81.27	4.58
3	10600.00	53.5 PK	74.0	-20.5	1.00 H	180	38.09	15.41
4	10600.00	41.4 AV	54.0	-12.6	1.00 H	180	25.97	15.41
ANTENNA POLARITY & TEST DISTANCE: VERTICAL AT 3 M								
NO.	FREQ. (MHz)	EMISSION LEVEL (dBuV/m)	LIMIT (dBuV/m)	MARGIN (dB)	ANTENNA HEIGHT (m)	TABLE ANGLE (Degree)	RAW VALUE (dBuV)	CORRECTION FACTOR (dB/m)
1	*5300.00	101.2 PK			1.00 V	4	96.59	4.58
2	*5300.00	91.7 AV			1.00 V	4	87.15	4.58
3	10600.00	54.8 PK	74.0	-19.2	1.00 V	4	39.42	15.41
4	10600.00	42.7 AV	54.0	-11.3	1.00 V	4	27.27	15.41

REMARKS:

1. Emission Level(dBuV/m) = Raw Value(dBuV) + Correction Factor(dB/m)
2. Correction Factor(dB/m) = Antenna Factor(dB/m) + Cable Factor(dB) – Pre-Amplifier Factor(dB)
3. The other emission levels were very low against the limit.
4. Margin value = Emission Level – Limit value
5. " * ": Fundamental frequency.

CHANNEL	TX Channel 64	DETECTOR FUNCTION	Peak (PK)
FREQUENCY RANGE	1GHz ~ 40GHz		Average (AV)

ANTENNA POLARITY & TEST DISTANCE: HORIZONTAL AT 3 M								
NO.	FREQ. (MHz)	EMISSION LEVEL (dBuV/m)	LIMIT (dBuV/m)	MARGIN (dB)	ANTENNA HEIGHT (m)	TABLE ANGLE (Degree)	RAW VALUE (dBuV)	CORRECTION FACTOR (dB/m)
1	*5320.00	95.9 PK			1.00 H	198	91.31	4.63
2	*5320.00	86.6 AV			1.00 H	198	81.97	4.63
3	5350.00	54.0 PK	74.0	-20.0	1.00 H	198	49.25	4.71
4	5350.00	42.6 AV	54.0	-11.5	1.00 H	198	37.84	4.71
5	10640.00	53.2 PK	74.0	-20.8	1.00 H	198	37.84	15.35
6	10640.00	41.5 AV	54.0	-12.5	1.00 H	198	26.16	15.35

ANTENNA POLARITY & TEST DISTANCE: VERTICAL AT 3 M								
NO.	FREQ. (MHz)	EMISSION LEVEL (dBuV/m)	LIMIT (dBuV/m)	MARGIN (dB)	ANTENNA HEIGHT (m)	TABLE ANGLE (Degree)	RAW VALUE (dBuV)	CORRECTION FACTOR (dB/m)
1	*5320.00	101.2 PK			1.00 V	4	96.57	4.63
2	*5320.00	91.7 AV			1.00 V	4	87.09	4.63
3	5350.00	58.2 PK	74.0	-15.8	1.00 V	5	53.53	4.71
4	5350.00	45.2 AV	54.0	-8.9	1.00 V	5	40.44	4.71
5	10640.00	55.1 PK	74.0	-18.9	1.00 V	4	39.76	15.35
6	10640.00	42.9 AV	54.0	-11.1	1.00 V	4	27.55	15.35

REMARKS:

1. Emission Level(dBuV/m) = Raw Value(dBuV) + Correction Factor(dB/m)
2. Correction Factor(dB/m) = Antenna Factor(dB/m) + Cable Factor(dB) – Pre-Amplifier Factor(dB)
3. The other emission levels were very low against the limit.
4. Margin value = Emission Level – Limit value
5. " * ": Fundamental frequency.

CHANNEL	TX Channel 100	DETECTOR FUNCTION	Peak (PK)
FREQUENCY RANGE	1GHz ~ 40GHz		Average (AV)

ANTENNA POLARITY & TEST DISTANCE: HORIZONTAL AT 3 M								
NO.	FREQ. (MHz)	EMISSION LEVEL (dBuV/m)	LIMIT (dBuV/m)	MARGIN (dB)	ANTENNA HEIGHT (m)	TABLE ANGLE (Degree)	RAW VALUE (dBuV)	CORRECTION FACTOR (dB/m)
1	5460.00	53.7 PK	74.0	-20.3	1.00 H	199	48.64	5.07
2	5460.00	41.6 AV	54.0	-12.4	1.00 H	199	36.54	5.07
3	5470.00	55.1 PK	74.0	-18.9	1.00 H	199	49.98	5.10
4	5470.00	42.5 AV	54.0	-11.5	1.00 H	199	37.36	5.10
5	*5500.00	92.5 PK			1.00 H	199	87.31	5.22
6	*5500.00	83.5 AV			1.00 H	199	78.32	5.22
7	11000.00	53.6 PK	74.0	-20.5	1.00 H	199	37.44	16.11
8	11000.00	41.4 AV	54.0	-12.6	1.00 H	199	25.26	16.11

ANTENNA POLARITY & TEST DISTANCE: VERTICAL AT 3 M								
NO.	FREQ. (MHz)	EMISSION LEVEL (dBuV/m)	LIMIT (dBuV/m)	MARGIN (dB)	ANTENNA HEIGHT (m)	TABLE ANGLE (Degree)	RAW VALUE (dBuV)	CORRECTION FACTOR (dB/m)
1	5460.00	55.5 PK	74.0	-18.5	1.00 V	356	50.42	5.07
2	5460.00	42.8 AV	54.0	-11.2	1.00 V	356	37.71	5.07
3	5470.00	57.2 PK	74.0	-16.8	1.00 V	356	52.14	5.10
4	5470.00	43.4 AV	54.0	-10.6	1.00 V	356	38.31	5.10
5	*5500.00	97.5 PK			1.00 V	356	92.31	5.22
6	*5500.00	88.0 AV			1.00 V	356	82.74	5.22
7	11000.00	54.0 PK	74.0	-20.0	1.00 V	354	37.88	16.11
8	11000.00	41.7 AV	54.0	-12.3	1.00 V	354	25.56	16.11

REMARKS:

1. Emission Level(dBuV/m) = Raw Value(dBuV) + Correction Factor(dB/m)
2. Correction Factor(dB/m) = Antenna Factor(dB/m) + Cable Factor(dB) – Pre-Amplifier Factor(dB)
3. The other emission levels were very low against the limit.
4. Margin value = Emission Level – Limit value
5. " * ": Fundamental frequency.

CHANNEL	TX Channel 116	DETECTOR FUNCTION	Peak (PK)
FREQUENCY RANGE	1GHz ~ 40GHz		Average (AV)

ANTENNA POLARITY & TEST DISTANCE: HORIZONTAL AT 3 M								
NO.	FREQ. (MHz)	EMISSION LEVEL (dBuV/m)	LIMIT (dBuV/m)	MARGIN (dB)	ANTENNA HEIGHT (m)	TABLE ANGLE (Degree)	RAW VALUE (dBuV)	CORRECTION FACTOR (dB/m)
1	*5580.00	93.1 PK			1.00 H	201	87.81	5.31
2	*5580.00	83.5 AV			1.00 H	201	78.16	5.31
3	11160.00	54.4 PK	74.0	-19.6	1.00 H	201	37.84	16.60
4	11160.00	42.0 AV	54.0	-12.0	1.00 H	201	25.43	16.60
ANTENNA POLARITY & TEST DISTANCE: VERTICAL AT 3 M								
NO.	FREQ. (MHz)	EMISSION LEVEL (dBuV/m)	LIMIT (dBuV/m)	MARGIN (dB)	ANTENNA HEIGHT (m)	TABLE ANGLE (Degree)	RAW VALUE (dBuV)	CORRECTION FACTOR (dB/m)
1	*5580.00	97.5 PK			1.00 V	325	92.18	5.31
2	*5580.00	88.2 AV			1.00 V	325	82.91	5.31
3	11160.00	55.0 PK	74.0	-19.0	1.00 V	325	38.41	16.60
4	11160.00	42.1 AV	54.0	-11.9	1.00 V	325	25.53	16.60

REMARKS:

1. Emission Level(dBuV/m) = Raw Value(dBuV) + Correction Factor(dB/m)
2. Correction Factor(dB/m) = Antenna Factor(dB/m) + Cable Factor(dB) – Pre-Amplifier Factor(dB)
3. The other emission levels were very low against the limit.
4. Margin value = Emission Level – Limit value
5. " * ": Fundamental frequency.

CHANNEL	TX Channel 140	DETECTOR FUNCTION	Peak (PK)
FREQUENCY RANGE	1GHz ~ 40GHz		Average (AV)

ANTENNA POLARITY & TEST DISTANCE: HORIZONTAL AT 3 M								
NO.	FREQ. (MHz)	EMISSION LEVEL (dBuV/m)	LIMIT (dBuV/m)	MARGIN (dB)	ANTENNA HEIGHT (m)	TABLE ANGLE (Degree)	RAW VALUE (dBuV)	CORRECTION FACTOR (dB/m)
1	*5700.00	93.0 PK			1.00 H	203	87.63	5.35
2	*5700.00	83.7 AV			1.00 H	203	78.32	5.35
3	5725.00	56.5 PK	74.0	-17.5	1.00 H	203	51.10	5.39
4	5725.00	42.5 AV	54.0	-11.5	1.00 H	203	37.13	5.39
5	11400.00	52.8 PK	74.0	-21.2	1.00 H	203	36.74	16.10
6	11400.00	41.2 AV	54.0	-12.8	1.00 H	203	25.13	16.10
ANTENNA POLARITY & TEST DISTANCE: VERTICAL AT 3 M								
NO.	FREQ. (MHz)	EMISSION LEVEL (dBuV/m)	LIMIT (dBuV/m)	MARGIN (dB)	ANTENNA HEIGHT (m)	TABLE ANGLE (Degree)	RAW VALUE (dBuV)	CORRECTION FACTOR (dB/m)
1	*5700.00	99.1 PK			1.00 V	319	93.77	5.35
2	*5700.00	89.7 AV			1.00 V	319	84.38	5.35
3	5725.00	61.9 PK	74.0	-12.1	1.00 V	319	56.55	5.39
4	5725.00	45.8 AV	54.0	-8.2	1.00 V	319	40.45	5.39
5	11400.00	53.9 PK	74.0	-20.1	1.00 V	320	37.78	16.10
6	11400.00	42.1 AV	54.0	-11.9	1.00 V	320	25.98	16.10

REMARKS:

1. Emission Level(dBuV/m) = Raw Value(dBuV) + Correction Factor(dB/m)
2. Correction Factor(dB/m) = Antenna Factor(dB/m) + Cable Factor(dB) – Pre-Amplifier Factor(dB)
3. The other emission levels were very low against the limit.
4. Margin value = Emission Level – Limit value
5. " * ": Fundamental frequency.



A D T

802.11n (20MHz)

CHANNEL	TX Channel 36	DETECTOR FUNCTION	Peak (PK)
FREQUENCY RANGE	1GHz ~ 40GHz		Average (AV)

ANTENNA POLARITY & TEST DISTANCE: HORIZONTAL AT 3 M								
NO.	FREQ. (MHz)	EMISSION LEVEL (dBuV/m)	LIMIT (dBuV/m)	MARGIN (dB)	ANTENNA HEIGHT (m)	TABLE ANGLE (Degree)	RAW VALUE (dBuV)	CORRECTION FACTOR (dB/m)
1	5150.00	53.0 PK	74.0	-21.0	1.00 H	180	48.98	4.05
2	5150.00	41.2 AV	54.0	-12.8	1.00 H	180	37.18	4.05
3	*5180.00	91.6 PK			1.00 H	180	87.41	4.14
4	*5180.00	79.7 AV			1.00 H	180	75.51	4.14
5	10360.00	52.6 PK	74.0	-21.4	1.00 H	180	37.87	14.73
6	10360.00	41.1 AV	54.0	-12.9	1.00 H	180	26.37	14.73
ANTENNA POLARITY & TEST DISTANCE: VERTICAL AT 3 M								
NO.	FREQ. (MHz)	EMISSION LEVEL (dBuV/m)	LIMIT (dBuV/m)	MARGIN (dB)	ANTENNA HEIGHT (m)	TABLE ANGLE (Degree)	RAW VALUE (dBuV)	CORRECTION FACTOR (dB/m)
1	5150.00	53.4 PK	74.0	-20.6	1.00 V	286	49.31	4.05
2	5150.00	41.5 AV	54.0	-12.5	1.00 V	286	37.43	4.05
3	*5180.00	97.2 PK			1.00 V	286	93.09	4.14
4	*5180.00	85.9 AV			1.00 V	286	81.74	4.14
5	10360.00	52.9 PK	74.0	-21.1	1.00 V	286	38.13	14.73
6	10360.00	40.9 AV	54.0	-13.1	1.00 V	286	26.18	14.73

REMARKS:

1. Emission Level(dBuV/m) = Raw Value(dBuV) + Correction Factor(dB/m)
2. Correction Factor(dB/m) = Antenna Factor(dB/m) + Cable Factor(dB) – Pre-Amplifier Factor(dB)
3. The other emission levels were very low against the limit.
4. Margin value = Emission Level – Limit value
5. " * ": Fundamental frequency.

CHANNEL	TX Channel 40	DETECTOR FUNCTION	Peak (PK)
FREQUENCY RANGE	1GHz ~ 40GHz		Average (AV)

ANTENNA POLARITY & TEST DISTANCE: HORIZONTAL AT 3 M								
NO.	FREQ. (MHz)	EMISSION LEVEL (dBuV/m)	LIMIT (dBuV/m)	MARGIN (dB)	ANTENNA HEIGHT (m)	TABLE ANGLE (Degree)	RAW VALUE (dBuV)	CORRECTION FACTOR (dB/m)
1	*5200.00	90.5 PK			1.00 H	181	86.28	4.19
2	*5200.00	79.0 AV			1.00 H	181	74.77	4.19
3	10400.00	52.6 PK	74.0	-21.4	1.00 H	181	37.44	15.12
4	10400.00	40.3 AV	54.0	-13.7	1.00 H	181	25.14	15.12
ANTENNA POLARITY & TEST DISTANCE: VERTICAL AT 3 M								
NO.	FREQ. (MHz)	EMISSION LEVEL (dBuV/m)	LIMIT (dBuV/m)	MARGIN (dB)	ANTENNA HEIGHT (m)	TABLE ANGLE (Degree)	RAW VALUE (dBuV)	CORRECTION FACTOR (dB/m)
1	*5200.00	96.0 PK			1.00 V	278	91.85	4.19
2	*5200.00	84.9 AV			1.00 V	278	80.69	4.19
3	10400.00	52.8 PK	74.0	-21.2	1.00 V	278	37.69	15.12
4	10400.00	40.4 AV	54.0	-13.6	1.00 V	278	25.24	15.12

REMARKS:

1. Emission Level(dBuV/m) = Raw Value(dBuV) + Correction Factor(dB/m)
2. Correction Factor(dB/m) = Antenna Factor(dB/m) + Cable Factor(dB) – Pre-Amplifier Factor(dB)
3. The other emission levels were very low against the limit.
4. Margin value = Emission Level – Limit value
5. " * ": Fundamental frequency.

CHANNEL	TX Channel 48	DETECTOR FUNCTION	Peak (PK)
FREQUENCY RANGE	1GHz ~ 40GHz		Average (AV)

ANTENNA POLARITY & TEST DISTANCE: HORIZONTAL AT 3 M								
NO.	FREQ. (MHz)	EMISSION LEVEL (dBuV/m)	LIMIT (dBuV/m)	MARGIN (dB)	ANTENNA HEIGHT (m)	TABLE ANGLE (Degree)	RAW VALUE (dBuV)	CORRECTION FACTOR (dB/m)
1	*5240.00	91.8 PK			1.00 H	84	87.43	4.35
2	*5240.00	80.9 AV			1.00 H	84	76.57	4.35
3	10480.00	52.2 PK	74.0	-21.8	1.00 H	85	37.29	14.92
4	10480.00	40.2 AV	54.0	-13.8	1.00 H	85	25.28	14.92

ANTENNA POLARITY & TEST DISTANCE: VERTICAL AT 3 M								
NO.	FREQ. (MHz)	EMISSION LEVEL (dBuV/m)	LIMIT (dBuV/m)	MARGIN (dB)	ANTENNA HEIGHT (m)	TABLE ANGLE (Degree)	RAW VALUE (dBuV)	CORRECTION FACTOR (dB/m)
1	*5240.00	97.7 PK			1.00 V	278	93.31	4.35
2	*5240.00	85.8 AV			1.00 V	278	81.40	4.35
3	10480.00	52.2 PK	74.0	-21.8	1.00 V	278	37.31	14.92
4	10480.00	40.9 AV	54.0	-13.1	1.00 V	278	25.94	14.92

REMARKS:

1. Emission Level(dBuV/m) = Raw Value(dBuV) + Correction Factor(dB/m)
2. Correction Factor(dB/m) = Antenna Factor(dB/m) + Cable Factor(dB) – Pre-Amplifier Factor(dB)
3. The other emission levels were very low against the limit.
4. Margin value = Emission Level – Limit value
5. " * ": Fundamental frequency.

CHANNEL	TX Channel 52	DETECTOR FUNCTION	Peak (PK)
FREQUENCY RANGE	1GHz ~ 40GHz		Average (AV)

ANTENNA POLARITY & TEST DISTANCE: HORIZONTAL AT 3 M								
NO.	FREQ. (MHz)	EMISSION LEVEL (dBuV/m)	LIMIT (dBuV/m)	MARGIN (dB)	ANTENNA HEIGHT (m)	TABLE ANGLE (Degree)	RAW VALUE (dBuV)	CORRECTION FACTOR (dB/m)
1	*5260.00	94.0 PK			1.00 H	199	89.58	4.42
2	*5260.00	82.0 AV			1.00 H	199	77.59	4.42
3	10520.00	56.8 PK	74.0	-17.2	1.00 H	199	41.84	14.98
4	10520.00	43.3 AV	54.0	-10.7	1.00 H	199	28.35	14.98
ANTENNA POLARITY & TEST DISTANCE: VERTICAL AT 3 M								
NO.	FREQ. (MHz)	EMISSION LEVEL (dBuV/m)	LIMIT (dBuV/m)	MARGIN (dB)	ANTENNA HEIGHT (m)	TABLE ANGLE (Degree)	RAW VALUE (dBuV)	CORRECTION FACTOR (dB/m)
1	*5260.00	98.8 PK			1.00 V	25	94.39	4.42
2	*5260.00	87.5 AV			1.00 V	25	83.08	4.42
3	10520.00	53.2 PK	74.0	-20.8	1.00 V	25	38.22	14.98
4	10520.00	40.8 AV	54.0	-13.2	1.00 V	25	25.83	14.98

REMARKS:

1. Emission Level(dBuV/m) = Raw Value(dBuV) + Correction Factor(dB/m)
2. Correction Factor(dB/m) = Antenna Factor(dB/m) + Cable Factor(dB) – Pre-Amplifier Factor(dB)
3. The other emission levels were very low against the limit.
4. Margin value = Emission Level – Limit value
5. " * ": Fundamental frequency.

CHANNEL	TX Channel 60	DETECTOR FUNCTION	Peak (PK)
FREQUENCY RANGE	1GHz ~ 40GHz		Average (AV)

ANTENNA POLARITY & TEST DISTANCE: HORIZONTAL AT 3 M								
NO.	FREQ. (MHz)	EMISSION LEVEL (dBuV/m)	LIMIT (dBuV/m)	MARGIN (dB)	ANTENNA HEIGHT (m)	TABLE ANGLE (Degree)	RAW VALUE (dBuV)	CORRECTION FACTOR (dB/m)
1	*5300.00	91.8 PK			1.00 H	199	87.26	4.58
2	*5300.00	81.2 AV			1.00 H	199	76.61	4.58
3	10600.00	54.0 PK	74.0	-20.0	1.00 H	201	38.55	15.41
4	10600.00	41.2 AV	54.0	-12.9	1.00 H	201	25.74	15.41
ANTENNA POLARITY & TEST DISTANCE: VERTICAL AT 3 M								
NO.	FREQ. (MHz)	EMISSION LEVEL (dBuV/m)	LIMIT (dBuV/m)	MARGIN (dB)	ANTENNA HEIGHT (m)	TABLE ANGLE (Degree)	RAW VALUE (dBuV)	CORRECTION FACTOR (dB/m)
1	*5300.00	97.9 PK			1.00 V	6	93.32	4.58
2	*5300.00	86.7 AV			1.00 V	6	82.08	4.58
3	10600.00	53.7 PK	74.0	-20.3	1.00 V	8	38.30	15.41
4	10600.00	41.4 AV	54.0	-12.6	1.00 V	8	25.96	15.41

REMARKS:

1. Emission Level(dBuV/m) = Raw Value(dBuV) + Correction Factor(dB/m)
2. Correction Factor(dB/m) = Antenna Factor(dB/m) + Cable Factor(dB) – Pre-Amplifier Factor(dB)
3. The other emission levels were very low against the limit.
4. Margin value = Emission Level – Limit value
5. " * ": Fundamental frequency.

CHANNEL	TX Channel 64	DETECTOR FUNCTION	Peak (PK)
FREQUENCY RANGE	1GHz ~ 40GHz		Average (AV)

ANTENNA POLARITY & TEST DISTANCE: HORIZONTAL AT 3 M								
NO.	FREQ. (MHz)	EMISSION LEVEL (dBuV/m)	LIMIT (dBuV/m)	MARGIN (dB)	ANTENNA HEIGHT (m)	TABLE ANGLE (Degree)	RAW VALUE (dBuV)	CORRECTION FACTOR (dB/m)
1	*5320.00	92.4 PK			1.00 H	200	87.72	4.63
2	*5320.00	80.6 AV			1.00 H	200	75.96	4.63
3	5350.00	53.6 PK	74.0	-20.5	1.00 H	200	48.84	4.71
4	5350.00	41.6 AV	54.0	-12.4	1.00 H	200	36.91	4.71
5	10640.00	53.0 PK	74.0	-21.0	1.00 H	200	37.66	15.35
6	10640.00	41.2 AV	54.0	-12.8	1.00 H	200	25.83	15.35
ANTENNA POLARITY & TEST DISTANCE: VERTICAL AT 3 M								
NO.	FREQ. (MHz)	EMISSION LEVEL (dBuV/m)	LIMIT (dBuV/m)	MARGIN (dB)	ANTENNA HEIGHT (m)	TABLE ANGLE (Degree)	RAW VALUE (dBuV)	CORRECTION FACTOR (dB/m)
1	*5320.00	98.4 PK			1.00 V	4	93.77	4.63
2	*5320.00	86.9 AV			1.00 V	4	82.31	4.63
3	5350.00	54.2 PK	74.0	-19.8	1.00 V	5	49.47	4.71
4	5350.00	42.1 AV	54.0	-11.9	1.00 V	5	37.37	4.71
5	10640.00	53.7 PK	74.0	-20.3	1.00 V	7	38.33	15.35
6	10640.00	41.5 AV	54.0	-12.5	1.00 V	7	26.16	15.35

REMARKS:

1. Emission Level(dBuV/m) = Raw Value(dBuV) + Correction Factor(dB/m)
2. Correction Factor(dB/m) = Antenna Factor(dB/m) + Cable Factor(dB) – Pre-Amplifier Factor(dB)
3. The other emission levels were very low against the limit.
4. Margin value = Emission Level – Limit value
5. " * ": Fundamental frequency.

CHANNEL	TX Channel 100	DETECTOR FUNCTION	Peak (PK)
FREQUENCY RANGE	1GHz ~ 40GHz		Average (AV)

ANTENNA POLARITY & TEST DISTANCE: HORIZONTAL AT 3 M								
NO.	FREQ. (MHz)	EMISSION LEVEL (dBuV/m)	LIMIT (dBuV/m)	MARGIN (dB)	ANTENNA HEIGHT (m)	TABLE ANGLE (Degree)	RAW VALUE (dBuV)	CORRECTION FACTOR (dB/m)
1	5460.00	53.4 PK	74.0	-20.6	1.00 H	199	48.31	5.07
2	5460.00	40.6 AV	54.0	-13.4	1.00 H	199	35.55	5.07
3	5470.00	54.3 PK	74.0	-19.8	1.00 H	199	49.15	5.10
4	5470.00	41.7 AV	54.0	-12.3	1.00 H	199	36.57	5.10
5	*5500.00	90.6 PK			1.00 H	199	85.36	5.22
6	*5500.00	78.7 AV			1.00 H	199	73.52	5.22
7	11000.00	53.7 PK	74.0	-20.3	1.00 H	197	37.61	16.11
8	11000.00	41.3 AV	54.0	-12.7	1.00 H	197	25.23	16.11

ANTENNA POLARITY & TEST DISTANCE: VERTICAL AT 3 M								
NO.	FREQ. (MHz)	EMISSION LEVEL (dBuV/m)	LIMIT (dBuV/m)	MARGIN (dB)	ANTENNA HEIGHT (m)	TABLE ANGLE (Degree)	RAW VALUE (dBuV)	CORRECTION FACTOR (dB/m)
1	5460.00	53.3 PK	74.0	-20.7	1.00 V	0	48.21	5.07
2	5460.00	41.2 AV	54.0	-12.8	1.00 V	0	36.12	5.07
3	5470.00	54.1 PK	74.0	-19.9	1.00 V	0	48.99	5.10
4	5470.00	42.0 AV	54.0	-12.0	1.00 V	0	36.93	5.10
5	*5500.00	94.6 PK			1.00 V	0	89.33	5.22
6	*5500.00	83.4 AV			1.00 V	0	78.19	5.22
7	11000.00	53.9 PK	74.0	-20.1	1.00 V	4	37.76	16.11
8	11000.00	41.3 AV	54.0	-12.7	1.00 V	4	25.21	16.11

REMARKS:

1. Emission Level(dBuV/m) = Raw Value(dBuV) + Correction Factor(dB/m)
2. Correction Factor(dB/m) = Antenna Factor(dB/m) + Cable Factor(dB) – Pre-Amplifier Factor(dB)
3. The other emission levels were very low against the limit.
4. Margin value = Emission Level – Limit value
5. " * ": Fundamental frequency.

CHANNEL	TX Channel 116	DETECTOR FUNCTION	Peak (PK)
FREQUENCY RANGE	1GHz ~ 40GHz		Average (AV)

ANTENNA POLARITY & TEST DISTANCE: HORIZONTAL AT 3 M								
NO.	FREQ. (MHz)	EMISSION LEVEL (dBuV/m)	LIMIT (dBuV/m)	MARGIN (dB)	ANTENNA HEIGHT (m)	TABLE ANGLE (Degree)	RAW VALUE (dBuV)	CORRECTION FACTOR (dB/m)
1	*5580.00	91.0 PK			1.00 H	201	85.66	5.31
2	*5580.00	79.8 AV			1.00 H	201	74.49	5.31
3	11160.00	53.7 PK	74.0	-20.4	1.00 H	201	37.05	16.60
4	11160.00	41.8 AV	54.0	-12.2	1.00 H	201	25.20	16.60
ANTENNA POLARITY & TEST DISTANCE: VERTICAL AT 3 M								
NO.	FREQ. (MHz)	EMISSION LEVEL (dBuV/m)	LIMIT (dBuV/m)	MARGIN (dB)	ANTENNA HEIGHT (m)	TABLE ANGLE (Degree)	RAW VALUE (dBuV)	CORRECTION FACTOR (dB/m)
1	*5580.00	93.9 PK			1.00 V	16	88.59	5.31
2	*5580.00	83.1 AV			1.00 V	16	77.83	5.31
3	11160.00	54.3 PK	74.0	-19.7	1.00 V	20	37.73	16.60
4	11160.00	41.7 AV	54.0	-12.3	1.00 V	20	25.14	16.60

REMARKS:

1. Emission Level(dBuV/m) = Raw Value(dBuV) + Correction Factor(dB/m)
2. Correction Factor(dB/m) = Antenna Factor(dB/m) + Cable Factor(dB) – Pre-Amplifier Factor(dB)
3. The other emission levels were very low against the limit.
4. Margin value = Emission Level – Limit value
5. " * ": Fundamental frequency.

CHANNEL	TX Channel 140	DETECTOR FUNCTION	Peak (PK)
FREQUENCY RANGE	1GHz ~ 40GHz		Average (AV)

ANTENNA POLARITY & TEST DISTANCE: HORIZONTAL AT 3 M								
NO.	FREQ. (MHz)	EMISSION LEVEL (dBuV/m)	LIMIT (dBuV/m)	MARGIN (dB)	ANTENNA HEIGHT (m)	TABLE ANGLE (Degree)	RAW VALUE (dBuV)	CORRECTION FACTOR (dB/m)
1	*5700.00	90.4 PK			1.00 H	202	85.02	5.35
2	*5700.00	79.0 AV			1.00 H	202	73.61	5.35
3	5725.00	53.6 PK	74.0	-20.4	1.00 H	202	48.23	5.39
4	5725.00	42.1 AV	54.0	-11.9	1.00 H	202	36.69	5.39
5	11400.00	52.8 PK	74.0	-21.3	1.00 H	202	36.65	16.10
6	11400.00	42.0 AV	54.0	-12.0	1.00 H	202	25.91	16.10
ANTENNA POLARITY & TEST DISTANCE: VERTICAL AT 3 M								
NO.	FREQ. (MHz)	EMISSION LEVEL (dBuV/m)	LIMIT (dBuV/m)	MARGIN (dB)	ANTENNA HEIGHT (m)	TABLE ANGLE (Degree)	RAW VALUE (dBuV)	CORRECTION FACTOR (dB/m)
1	*5700.00	96.3 PK			1.00 V	189	90.96	5.35
2	*5700.00	84.6 AV			1.00 V	189	79.29	5.35
3	5725.00	53.4 PK	74.0	-20.6	1.00 V	189	48.01	5.39
4	5725.00	42.4 AV	54.0	-11.6	1.00 V	189	36.98	5.39
5	11400.00	53.4 PK	74.0	-20.6	1.00 V	189	37.34	16.10
6	11400.00	42.3 AV	54.0	-11.7	1.00 V	189	26.17	16.10

REMARKS:

1. Emission Level(dBuV/m) = Raw Value(dBuV) + Correction Factor(dB/m)
2. Correction Factor(dB/m) = Antenna Factor(dB/m) + Cable Factor(dB) – Pre-Amplifier Factor(dB)
3. The other emission levels were very low against the limit.
4. Margin value = Emission Level – Limit value
5. " * ": Fundamental frequency.
6. " # ": The radiated frequency is out of the restricted band.

802.11n (40MHz)

CHANNEL	TX Channel 38	DETECTOR FUNCTION	Peak (PK)
FREQUENCY RANGE	1GHz ~ 40GHz		Average (AV)

ANTENNA POLARITY & TEST DISTANCE: HORIZONTAL AT 3 M								
NO.	FREQ. (MHz)	EMISSION LEVEL (dBuV/m)	LIMIT (dBuV/m)	MARGIN (dB)	ANTENNA HEIGHT (m)	TABLE ANGLE (Degree)	RAW VALUE (dBuV)	CORRECTION FACTOR (dB/m)
1	5150.00	57.0 PK	74.0	-17.0	1.00 H	354	52.99	4.05
2	5150.00	43.1 AV	54.0	-10.9	1.00 H	354	39.01	4.05
3	*5190.00	92.5 PK			1.00 H	354	88.36	4.16
4	*5190.00	81.8 AV			1.00 H	354	77.67	4.16
5	10380.00	52.7 PK	74.0	-21.3	1.00 H	354	37.77	14.92
6	10380.00	41.2 AV	54.0	-12.9	1.00 H	354	26.23	14.92
ANTENNA POLARITY & TEST DISTANCE: VERTICAL AT 3 M								
NO.	FREQ. (MHz)	EMISSION LEVEL (dBuV/m)	LIMIT (dBuV/m)	MARGIN (dB)	ANTENNA HEIGHT (m)	TABLE ANGLE (Degree)	RAW VALUE (dBuV)	CORRECTION FACTOR (dB/m)
1	5150.00	60.2 PK	74.0	-13.8	1.00 V	15	56.11	4.05
2	5150.00	44.6 AV	54.0	-9.4	1.00 V	15	40.52	4.05
3	*5190.00	95.4 PK			1.00 V	15	91.21	4.16
4	*5190.00	84.4 AV			1.00 V	15	80.22	4.16
5	10380.00	52.3 PK	74.0	-21.7	1.00 V	15	37.40	14.92
6	10380.00	41.5 AV	54.0	-12.5	1.00 V	15	26.54	14.92

REMARKS:

1. Emission Level(dBuV/m) = Raw Value(dBuV) + Correction Factor(dB/m)
2. Correction Factor(dB/m) = Antenna Factor(dB/m) + Cable Factor(dB) – Pre-Amplifier Factor(dB)
3. The other emission levels were very low against the limit.
4. Margin value = Emission Level – Limit value
5. " * ": Fundamental frequency.



A D T

CHANNEL	TX Channel 46	DETECTOR FUNCTION	Peak (PK)
FREQUENCY RANGE	1GHz ~ 40GHz		Average (AV)

ANTENNA POLARITY & TEST DISTANCE: HORIZONTAL AT 3 M								
NO.	FREQ. (MHz)	EMISSION LEVEL (dBuV/m)	LIMIT (dBuV/m)	MARGIN (dB)	ANTENNA HEIGHT (m)	TABLE ANGLE (Degree)	RAW VALUE (dBuV)	CORRECTION FACTOR (dB/m)
1	*5230.00	92.1 PK			1.02 H	353	87.75	4.31
2	*5230.00	81.3 AV			1.02 H	353	77.02	4.31
3	10460.00	53.0 PK	74.0	-21.1	1.00 H	353	37.98	14.97
4	10460.00	40.8 AV	54.0	-13.2	1.00 H	353	25.87	14.97

ANTENNA POLARITY & TEST DISTANCE: VERTICAL AT 3 M								
NO.	FREQ. (MHz)	EMISSION LEVEL (dBuV/m)	LIMIT (dBuV/m)	MARGIN (dB)	ANTENNA HEIGHT (m)	TABLE ANGLE (Degree)	RAW VALUE (dBuV)	CORRECTION FACTOR (dB/m)
1	*5230.00	96.3 PK			1.00 V	85	92.02	4.31
2	*5230.00	85.6 AV			1.00 V	85	81.27	4.31
3	10460.00	52.5 PK	74.0	-21.5	1.00 V	85	37.54	14.97
4	10460.00	40.7 AV	54.0	-13.3	1.00 V	85	25.77	14.97

REMARKS:

1. Emission Level(dBuV/m) = Raw Value(dBuV) + Correction Factor(dB/m)
2. Correction Factor(dB/m) = Antenna Factor(dB/m) + Cable Factor(dB) – Pre-Amplifier Factor(dB)
3. The other emission levels were very low against the limit.
4. Margin value = Emission Level – Limit value
5. " * ": Fundamental frequency.



A D T

CHANNEL	TX Channel 54	DETECTOR FUNCTION	Peak (PK)
FREQUENCY RANGE	1GHz ~ 40GHz		Average (AV)

ANTENNA POLARITY & TEST DISTANCE: HORIZONTAL AT 3 M

NO.	FREQ. (MHz)	EMISSION LEVEL (dBuV/m)	LIMIT (dBuV/m)	MARGIN (dB)	ANTENNA HEIGHT (m)	TABLE ANGLE (Degree)	RAW VALUE (dBuV)	CORRECTION FACTOR (dB/m)
1	*5270.00	91.6 PK			1.00 H	353	87.14	4.47
2	*5270.00	80.2 AV			1.00 H	353	75.69	4.47
3	10540.00	52.9 PK	74.0	-21.1	1.00 H	353	37.81	15.08
4	10540.00	41.0 AV	54.0	-13.1	1.00 H	353	25.87	15.08

ANTENNA POLARITY & TEST DISTANCE: VERTICAL AT 3 M

NO.	FREQ. (MHz)	EMISSION LEVEL (dBuV/m)	LIMIT (dBuV/m)	MARGIN (dB)	ANTENNA HEIGHT (m)	TABLE ANGLE (Degree)	RAW VALUE (dBuV)	CORRECTION FACTOR (dB/m)
1	*5270.00	95.8 PK			1.00 V	170	91.32	4.47
2	*5270.00	85.3 AV			1.00 V	170	80.86	4.47
3	10540.00	56.3 PK	74.0	-17.8	1.00 V	170	41.17	15.08
4	10540.00	42.5 AV	54.0	-11.5	1.00 V	170	27.41	15.08

REMARKS:

1. Emission Level(dBuV/m) = Raw Value(dBuV) + Correction Factor(dB/m)
2. Correction Factor(dB/m) = Antenna Factor(dB/m) + Cable Factor(dB) – Pre-Amplifier Factor(dB)
3. The other emission levels were very low against the limit.
4. Margin value = Emission Level – Limit value
5. " * ": Fundamental frequency.



A D T

CHANNEL	TX Channel 62	DETECTOR FUNCTION	Peak (PK)
FREQUENCY RANGE	1GHz ~ 40GHz		Average (AV)

ANTENNA POLARITY & TEST DISTANCE: HORIZONTAL AT 3 M

NO.	FREQ. (MHz)	EMISSION LEVEL (dBuV/m)	LIMIT (dBuV/m)	MARGIN (dB)	ANTENNA HEIGHT (m)	TABLE ANGLE (Degree)	RAW VALUE (dBuV)	CORRECTION FACTOR (dB/m)
1	*5310.00	91.0 PK			1.00 H	358	86.39	4.60
2	*5310.00	80.0 AV			1.00 H	358	75.41	4.60
3	5350.00	55.5 PK	74.0	-18.5	1.00 H	358	50.82	4.71
4	5350.00	42.5 AV	54.0	-11.5	1.00 H	358	37.83	4.71
5	10620.00	53.0 PK	74.0	-21.0	1.00 H	358	37.62	15.39
6	10620.00	41.1 AV	54.0	-12.9	1.00 H	358	25.74	15.39

ANTENNA POLARITY & TEST DISTANCE: VERTICAL AT 3 M

NO.	FREQ. (MHz)	EMISSION LEVEL (dBuV/m)	LIMIT (dBuV/m)	MARGIN (dB)	ANTENNA HEIGHT (m)	TABLE ANGLE (Degree)	RAW VALUE (dBuV)	CORRECTION FACTOR (dB/m)
1	*5310.00	96.3 PK			1.00 V	170	91.72	4.60
2	*5310.00	86.0 AV			1.00 V	170	81.41	4.60
3	5350.00	59.3 PK	74.0	-14.7	1.00 V	170	54.59	4.71
4	5350.00	44.4 AV	54.0	-9.6	1.00 V	170	39.73	4.71
5	10620.00	53.3 PK	74.0	-20.7	1.00 V	170	37.89	15.39
6	10620.00	41.7 AV	54.0	-12.3	1.00 V	170	26.31	15.39

REMARKS:

1. Emission Level(dBuV/m) = Raw Value(dBuV) + Correction Factor(dB/m)
2. Correction Factor(dB/m) = Antenna Factor(dB/m) + Cable Factor(dB) – Pre-Amplifier Factor(dB)
3. The other emission levels were very low against the limit.
4. Margin value = Emission Level – Limit value
5. " * ": Fundamental frequency.



A D T

CHANNEL	TX Channel 102	DETECTOR FUNCTION	Peak (PK)
FREQUENCY RANGE	1GHz ~ 40GHz		Average (AV)

ANTENNA POLARITY & TEST DISTANCE: HORIZONTAL AT 3 M

NO.	FREQ. (MHz)	EMISSION LEVEL (dBuV/m)	LIMIT (dBuV/m)	MARGIN (dB)	ANTENNA HEIGHT (m)	TABLE ANGLE (Degree)	RAW VALUE (dBuV)	CORRECTION FACTOR (dB/m)
1	5460.00	53.1 PK	74.0	-20.9	1.00 H	355	48.07	5.07
2	5460.00	41.4 AV	54.0	-12.6	1.00 H	355	36.36	5.07
3	5470.00	56.1 PK	74.0	-17.9	1.00 H	355	51.03	5.10
4	5470.00	42.8 AV	54.0	-11.2	1.00 H	355	37.72	5.10
5	*5510.00	90.1 PK			1.00 H	355	84.84	5.22
6	*5510.00	79.2 AV			1.00 H	355	73.99	5.22
7	11020.00	52.8 PK	74.0	-21.2	1.00 H	355	36.63	16.17
8	11020.00	41.9 AV	54.0	-12.1	1.00 H	355	25.73	16.17

ANTENNA POLARITY & TEST DISTANCE: VERTICAL AT 3 M

NO.	FREQ. (MHz)	EMISSION LEVEL (dBuV/m)	LIMIT (dBuV/m)	MARGIN (dB)	ANTENNA HEIGHT (m)	TABLE ANGLE (Degree)	RAW VALUE (dBuV)	CORRECTION FACTOR (dB/m)
1	5460.00	54.8 PK	74.0	-19.2	1.00 V	164	49.75	5.07
2	5460.00	42.2 AV	54.0	-11.8	1.00 V	164	37.09	5.07
3	5470.00	59.5 PK	74.0	-14.6	1.00 V	164	54.35	5.10
4	5470.00	43.7 AV	54.0	-10.3	1.00 V	164	38.57	5.10
5	*5510.00	96.2 PK			1.00 V	164	90.96	5.22
6	*5510.00	84.5 AV			1.00 V	164	79.29	5.22
7	11020.00	53.0 PK	74.0	-21.0	1.00 V	166	36.82	16.17
8	11020.00	41.9 AV	54.0	-12.1	1.00 V	166	25.75	16.17

REMARKS:

1. Emission Level(dBuV/m) = Raw Value(dBuV) + Correction Factor(dB/m)
2. Correction Factor(dB/m) = Antenna Factor(dB/m) + Cable Factor(dB) – Pre-Amplifier Factor(dB)
3. The other emission levels were very low against the limit.
4. Margin value = Emission Level – Limit value
5. " * ": Fundamental frequency.



A D T

CHANNEL	TX Channel 110	DETECTOR FUNCTION	Peak (PK)
FREQUENCY RANGE	1GHz ~ 40GHz		Average (AV)

ANTENNA POLARITY & TEST DISTANCE: HORIZONTAL AT 3 M								
NO.	FREQ. (MHz)	EMISSION LEVEL (dBuV/m)	LIMIT (dBuV/m)	MARGIN (dB)	ANTENNA HEIGHT (m)	TABLE ANGLE (Degree)	RAW VALUE (dBuV)	CORRECTION FACTOR (dB/m)
1	*5550.00	90.6 PK			1.00 H	357	85.28	5.27
2	*5550.00	80.4 AV			1.00 H	357	75.08	5.27
3	11100.00	54.0 PK	74.0	-20.0	1.00 H	357	37.56	16.47
4	11100.00	42.4 AV	54.0	-11.6	1.00 H	357	25.92	16.47

ANTENNA POLARITY & TEST DISTANCE: VERTICAL AT 3 M								
NO.	FREQ. (MHz)	EMISSION LEVEL (dBuV/m)	LIMIT (dBuV/m)	MARGIN (dB)	ANTENNA HEIGHT (m)	TABLE ANGLE (Degree)	RAW VALUE (dBuV)	CORRECTION FACTOR (dB/m)
1	*5550.00	94.7 PK			1.00 V	166	89.43	5.27
2	*5550.00	83.8 AV			1.00 V	166	78.57	5.27
3	11100.00	54.5 PK	74.0	-19.5	1.00 V	166	38.03	16.47
4	11100.00	42.4 AV	54.0	-11.6	1.00 V	166	25.93	16.47

REMARKS:

1. Emission Level(dBuV/m) = Raw Value(dBuV) + Correction Factor(dB/m)
2. Correction Factor(dB/m) = Antenna Factor(dB/m) + Cable Factor(dB) – Pre-Amplifier Factor(dB)
3. The other emission levels were very low against the limit.
4. Margin value = Emission Level – Limit value
5. " * ": Fundamental frequency.



A D T

CHANNEL	TX Channel 134	DETECTOR FUNCTION	Peak (PK)
FREQUENCY RANGE	1GHz ~ 40GHz		Average (AV)

ANTENNA POLARITY & TEST DISTANCE: HORIZONTAL AT 3 M

NO.	FREQ. (MHz)	EMISSION LEVEL (dBuV/m)	LIMIT (dBuV/m)	MARGIN (dB)	ANTENNA HEIGHT (m)	TABLE ANGLE (Degree)	RAW VALUE (dBuV)	CORRECTION FACTOR (dB/m)
1	*5670.00	88.7 PK			1.00 H	260	83.31	5.35
2	*5670.00	79.0 AV			1.00 H	260	73.62	5.35
3	5725.00	53.5 PK	74.0	-20.5	1.00 H	260	48.13	5.39
4	5725.00	41.9 AV	54.0	-12.2	1.00 H	260	36.46	5.39
5	11340.00	53.8 PK	74.0	-20.2	1.00 H	260	37.67	16.15
6	11340.00	41.7 AV	54.0	-12.3	1.00 H	260	25.58	16.15

ANTENNA POLARITY & TEST DISTANCE: VERTICAL AT 3 M

NO.	FREQ. (MHz)	EMISSION LEVEL (dBuV/m)	LIMIT (dBuV/m)	MARGIN (dB)	ANTENNA HEIGHT (m)	TABLE ANGLE (Degree)	RAW VALUE (dBuV)	CORRECTION FACTOR (dB/m)
1	*5670.00	94.3 PK			1.00 V	83	88.99	5.35
2	*5670.00	83.5 AV			1.00 V	83	78.11	5.35
3	5725.00	53.3 PK	74.0	-20.7	1.00 V	83	47.93	5.39
4	5725.00	42.1 AV	54.0	-11.9	1.00 V	83	36.75	5.39
5	11340.00	53.9 PK	74.0	-20.1	1.00 V	83	37.76	16.15
6	11340.00	42.3 AV	54.0	-11.7	1.00 V	83	26.17	16.15

REMARKS:

1. Emission Level(dBuV/m) = Raw Value(dBuV) + Correction Factor(dB/m)
2. Correction Factor(dB/m) = Antenna Factor(dB/m) + Cable Factor(dB) – Pre-Amplifier Factor(dB)
3. The other emission levels were very low against the limit.
4. Margin value = Emission Level – Limit value
5. " * ": Fundamental frequency.

BELOW 1GHz WORST-CASE DATA

802.11a

CHANNEL	TX Channel 52	DETECTOR FUNCTION	Quasi-Peak (QP)
FREQUENCY RANGE	30MHz ~ 1GHz		

ANTENNA POLARITY & TEST DISTANCE: HORIZONTAL AT 3 M

NO.	FREQ. (MHz)	EMISSION LEVEL (dBuV/m)	LIMIT (dBuV/m)	MARGIN (dB)	ANTENNA HEIGHT (m)	TABLE ANGLE (Degree)	RAW VALUE (dBuV)	CORRECTION FACTOR (dB/m)
1	35.27	32.1 QP	40.0	-7.9	1.22 H	125	46.71	-14.64
2	91.33	29.9 QP	43.5	-13.6	1.35 H	360	49.07	-19.15
3	166.53	35.3 QP	43.5	-8.2	1.00 H	171	48.84	-13.54
4	301.68	29.5 QP	46.0	-16.5	1.46 H	84	40.92	-11.38
5	424.26	30.8 QP	46.0	-15.2	1.69 H	360	39.84	-9.04
6	754.41	32.0 QP	46.0	-14.0	1.53 H	119	34.51	-2.49

ANTENNA POLARITY & TEST DISTANCE: VERTICAL AT 3 M

NO.	FREQ. (MHz)	EMISSION LEVEL (dBuV/m)	LIMIT (dBuV/m)	MARGIN (dB)	ANTENNA HEIGHT (m)	TABLE ANGLE (Degree)	RAW VALUE (dBuV)	CORRECTION FACTOR (dB/m)
1	166.45	34.2 QP	43.5	-9.3	1.78 V	36	47.72	-13.54
2	199.94	36.1 QP	43.5	-7.4	1.23 V	81	52.01	-15.95
3	301.71	39.0 QP	46.0	-7.0	1.24 V	132	50.38	-11.38
4	336.23	35.4 QP	46.0	-10.6	1.54 V	145	46.02	-10.65
5	384.29	34.4 QP	46.0	-11.6	1.33 V	247	44.22	-9.84
6	754.40	36.3 QP	46.0	-9.8	1.19 V	24	38.74	-2.49

REMARKS:

1. Emission Level(dBuV/m) = Raw Value(dBuV) + Correction Factor(dB/m)
2. Correction Factor(dB/m) = Antenna Factor(dB/m) + Cable Factor(dB) – Pre-Amplifier Factor(dB)
3. The other emission levels were very low against the limit.
4. Margin value = Emission Level – Limit value

4.2 CONDUCTED EMISSION MEASUREMENT

4.2.1 LIMITS OF CONDUCTED EMISSION MEASUREMENT

FREQUENCY OF EMISSION (MHz)	CONDUCTED LIMIT (dB μ V)	
	Quasi-peak	Average
0.15 ~ 0.5	66 to 56	56 to 46
0.5 ~ 5	56	46
5 ~ 30	60	50

- NOTE:** 1. The lower limit shall apply at the transition frequencies.
 2. The limit decreases in line with the logarithm of the frequency in the range of 0.15 to 0.50MHz.

4.2.2 TEST INSTRUMENTS

Description & Manufacturer	Model No.	Serial No.	Cal. Date	Cal. Due
ROHDE & SCHWARZ TEST RECEIVER	ESCS 30	100276	Jan. 07, 2014	Jan. 06, 2015
ROHDE & SCHWARZ Artificial Mains Network (for EUT)	ESH3-Z5	100219	Nov. 17, 2013	Nov. 16, 2014
LISN With Adapter (for EUT)	AD10	C10Ada-001	Nov. 17, 2013	Nov. 16, 2014
ROHDE & SCHWARZ Artificial Mains Network (for peripherals)	ESH3-Z5	100218	Nov. 25, 2013	Nov. 24, 2014
Software	ADT_Cond_V7.3.7	NA	NA	NA
Software	ADT_ISN_V7.3.7	NA	NA	NA
RF cable (JYEBAO)	5D-FB	Cable-C10.01	Feb. 19, 2013	Feb. 18, 2014
SUHNER Terminator (For ROHDE & SCHWARZ LISN)	65BNC-5001	E1-010773	Feb. 06, 2013	Feb. 05, 2014
Isolation Transformer (Erika Fiedler)	D-65396	017	Jul. 29, 2013	Jul. 28, 2014

- Notes: 1. The calibration interval of the above test instruments is 12 months and the calibrations are traceable to NML/ROC and NIST/USA.
 2. The test was performed in Shielded Room No. 10.
 3. The VCCI Site Registration No. C-1852.

4.2.3 TEST PROCEDURES

- The EUT was placed 0.4 meters from the conducting wall of the shielded room with EUT being connected to the power mains through a line impedance stabilization network (LISN). Other support units were connected to the power mains through another LISN. The two LISNs provide 50 ohm/ 50uH of coupling impedance for the measuring instrument.
- Both lines of the power mains connected to the EUT were checked for maximum conducted interference.
- The frequency range from 150kHz to 30MHz was searched. Emission levels under (Limit - 20dB) was not recorded.

NOTE: All modes of operation were investigated and the worst-case emissions are reported.

4.2.4 DEVIATION FROM TEST STANDARD

No deviation.

4.2.5 TEST SETUP

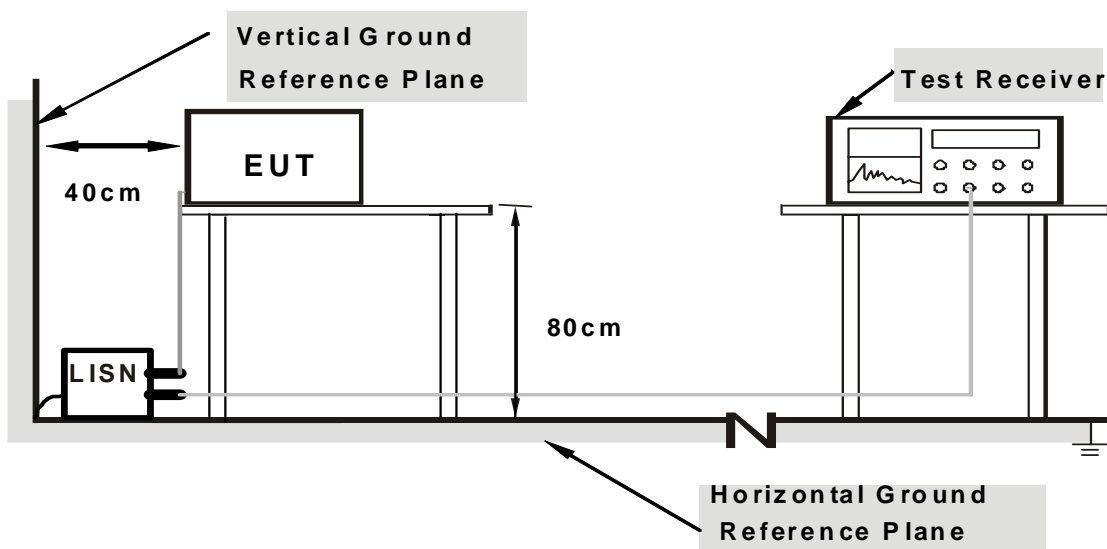

Note: Support units were connected to second LISN.

For the actual test configuration, please refer to the attached file (Test Setup Photo).

4.2.6 EUT OPERATING CONDITIONS

Same as 4.1.6.

4.2.7 TEST RESULTS

CONDUCTED WORST-CASE DATA : 802.11a

PHASE	Line 1	6dB BANDWIDTH	9kHz
-------	--------	---------------	------

No	Freq. [MHz]	Corr. Factor (dB)	Reading Value [dB (uV)]		Emission Level [dB (uV)]		Limit [dB (uV)]		Margin (dB)	
			Q.P.	AV.	Q.P.	AV.	Q.P.	AV.	Q.P.	AV.
			1	0.17344	0.14	40.36	25.30	40.50	25.44	64.79
2	0.23203	0.15	29.44	14.85	29.59	15.00	62.38	52.38	-32.78	-37.37
3	0.39609	0.17	20.55	10.26	20.72	10.43	57.93	47.93	-37.22	-37.51
4	4.51563	0.37	13.44	8.12	13.81	8.49	56.00	46.00	-42.19	-37.51
5	6.41016	0.50	16.00	10.80	16.50	11.30	60.00	50.00	-43.50	-38.70
6	17.03125	1.18	16.82	10.06	18.00	11.24	60.00	50.00	-42.00	-38.76

REMARKS:

1. Q.P. and AV. are abbreviations of quasi-peak and average individually.
2. The emission levels of other frequencies were very low against the limit.
3. Margin value = Emission Level – Limit value
4. Correction Factor = Insertion loss + Cable loss
5. Emission Level = Correction Factor + Reading Value

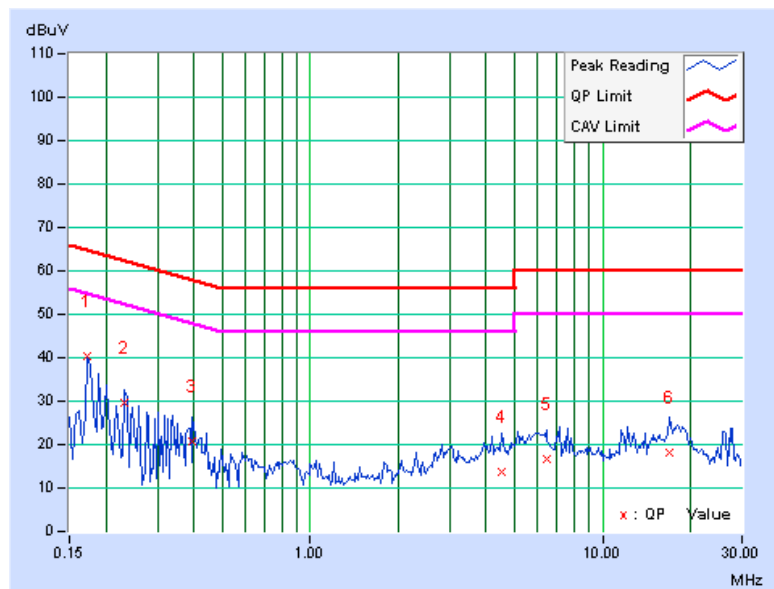



PHASE	Line 2	6dB BANDWIDTH	9kHz
--------------	--------	----------------------	------

No	Freq.	Corr. Factor	Reading Value		Emission Level		Limit		Margin	
	[MHz]		[dB (uV)]		[dB (uV)]		[dB (uV)]		(dB)	
			Q.P.	AV.	Q.P.	AV.	Q.P.	AV.	Q.P.	AV.
1	0.16562	0.53	40.57	25.96	41.10	26.49	65.18	55.18	-24.07	-28.68
2	0.19297	0.53	35.64	20.10	36.17	20.63	63.91	53.91	-27.74	-33.28
3	0.31016	0.54	21.77	5.87	22.31	6.41	59.97	49.97	-37.66	-43.56
4	2.82422	0.55	15.27	9.99	15.82	10.54	56.00	46.00	-40.18	-35.46
5	6.24609	0.67	18.77	12.70	19.44	13.37	60.00	50.00	-40.56	-36.63
6	15.21484	1.14	13.86	7.75	15.00	8.89	60.00	50.00	-45.00	-41.11

REMARKS:

1. Q.P. and AV. are abbreviations of quasi-peak and average individually.
2. The emission levels of other frequencies were very low against the limit.
3. Margin value = Emission Level – Limit value
4. Correction Factor = Insertion loss + Cable loss
5. Emission Level = Correction Factor + Reading Value

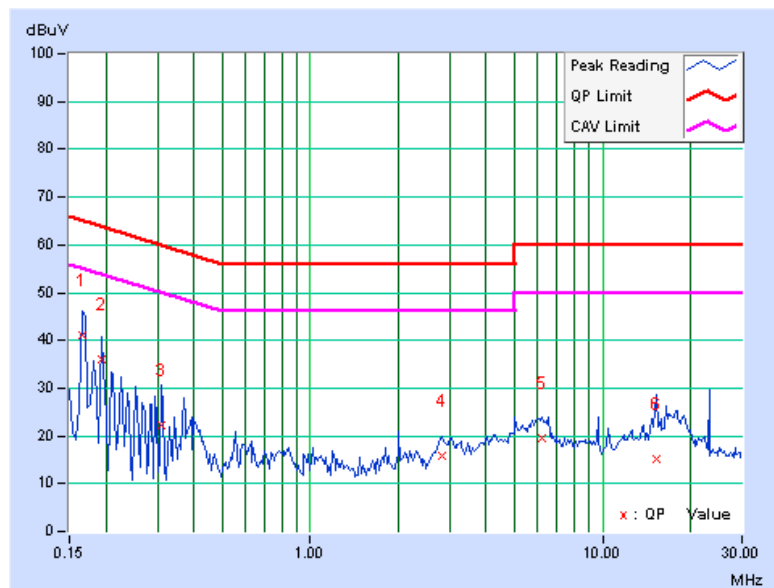

4.3 PEAK TRANSMIT POWER MEASUREMENT

4.3.1 LIMITS OF PEAK TRANSMIT POWER MEASUREMENT

FREQUENCY BAND	LIMIT
5.150 ~ 5.250GHz	The lesser of 50mW (17dBm) or 4dBm + 10logB
5.250 ~ 5.350GHz	The lesser of 250mW (24dBm) or 11dBm + 10logB
5.470 ~ 5.725GHz	The lesser of 250mW (24dBm) or 11dBm + 10logB

NOTE: Where B is the 26dB emission bandwidth in MHz.

Per 662911 D01 Multiple Transmitter Output v02 Method of conducted output power measurement on IEEE 802.11 devices,

Array Gain = 0 dB (i.e., no array gain) for NANT ≤ 4;

Array Gain = 0 dB (i.e., no array gain) for channel widths ≥ 40 MHz for any NANT;

Array Gain = 5 log(NANT/NSS) dB or 3 dB, whichever is less for 20-MHz channel widths with NANT ≥ 5.

For power measurements on all other devices: Array Gain = 10 log(NANT/NSS) dB.

4.3.2 TEST SETUP

FOR POWER OUTPUT MEASUREMENT

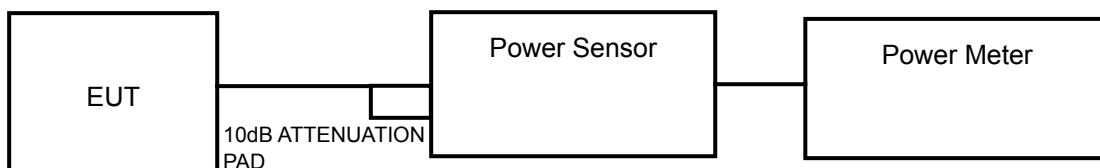

FOR 26dB BANDWIDTH

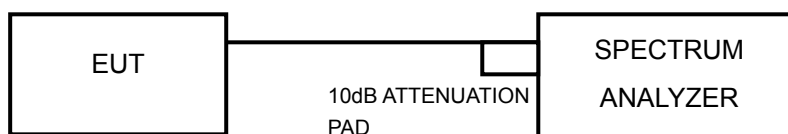

4.3.3 TEST INSTRUMENTS

Refer to section 4.1.3 to get information of above instrument.

4.3.4 TEST PROCEDURE

FOR AVERAGE POWER MEASUREMENT

Method PM is used to perform output power measurement, trigger and gating function of wide band power meter is enabled to measure max output power of TX on burst. Duty factor is not added to measured value.

FOR 26dB BANDWIDTH

- 1) Set RBW = approximately 1% of the emission bandwidth.
- 2) Set the VBW > RBW.
- 3) Detector = Peak.
- 4) Trace mode = max hold.
- 5) Measure the maximum width of the emission that is 26 dB down from the peak of the emission. Compare this with the RBW setting of the analyzer. Readjust RBW and repeat measurement as needed until the RBW/EBW ratio is approximately 1%.

4.3.5 DEVIATION FROM TEST STANDARD

No deviation.

4.3.6 EUT OPERATING CONDITIONS

The software provided by client to enable the EUT under transmission condition continuously at specific channel frequencies individually.

4.3.7 TEST RESULTS

POWER OUTPUT:

802.11a

CHANNEL	CHANNEL FREQUENCY (MHz)	AVERAGE POWER (dBm)	AVERAGE POWER (mW)	POWER LIMIT (dBm)	PASS/FAIL
36	5180	12.94	19.7	17.00	PASS
40	5200	12.93	19.6	17.00	PASS
48	5240	12.92	19.6	17.00	PASS
52	5260	13.14	20.6	23.99	PASS
60	5300	13.03	20.1	24.00	PASS
64	5320	13.11	20.5	24.00	PASS
100	5500	12.86	19.3	24.00	PASS
116	5580	12.69	18.6	24.00	PASS
140	5700	12.65	18.4	24.00	PASS

1. $4\text{dBm} + 10\log(19.98) = 17.01\text{ dBm} > 17\text{dBm}$.
2. $4\text{dBm} + 10\log(19.97) = 17.00\text{ dBm} > 17\text{dBm}$.
3. $4\text{dBm} + 10\log(20.15) = 17.04\text{ dBm} > 17\text{dBm}$.
4. $11\text{dBm} + 10\log(19.90) = 23.99\text{ dBm} < 24\text{dBm}$.
5. $11\text{dBm} + 10\log(20.05) = 24.02\text{ dBm} > 24\text{dBm}$.
6. $11\text{dBm} + 10\log(20.02) = 24.01\text{ dBm} > 24\text{dBm}$.
7. $11\text{dBm} + 10\log(20.09) = 24.03\text{ dBm} > 24\text{dBm}$.
8. $11\text{dBm} + 10\log(21.41) = 24.31\text{ dBm} > 24\text{dBm}$.
9. $11\text{dBm} + 10\log(29.36) = 25.68\text{ dBm} > 24\text{dBm}$.



802.11n (20MHz)

CHAN.	CHAN. FREQ. (MHz)	AVERAGE POWER (dBm)		TOTAL POWER (mW)	TOTAL POWER (dBm)	POWER LIMIT (dBm)	PASS / FAIL
		CHAIN 0	CHAIN 1				
36	5180	9.48	9.16	17.1	12.33	17	PASS
40	5200	9.28	9.01	16.4	12.16	17	PASS
48	5240	9.31	9.12	16.7	12.23	17	PASS
52	5260	9.36	8.92	16.4	12.16	24	PASS
60	5300	9.26	8.57	15.6	11.94	24	PASS
64	5320	9.38	8.61	15.9	12.02	24	PASS
100	5500	9.96	8.53	17.0	12.31	24	PASS
116	5580	9.82	8.18	16.2	12.09	24	PASS
140	5700	9.51	8.41	15.9	12.00	24	PASS

CHAIN 0

1. $4\text{dBm} + 10\log(20.87) = 17.20 \text{ dBm} >17\text{dBm}.$
2. $4\text{dBm} + 10\log(20.83) = 17.19 \text{ dBm} >17\text{dBm}.$
3. $4\text{dBm} + 10\log(20.95) = 17.21 \text{ dBm} >17\text{dBm}.$
4. $11\text{dBm} + 10\log(20.30) = 24.07 \text{ dBm} >24\text{dBm}.$
5. $11\text{dBm} + 10\log(20.66) = 24.15 \text{ dBm} >24\text{dBm}.$
6. $11\text{dBm} + 10\log(20.48) = 24.11 \text{ dBm} >24\text{dBm}.$
7. $11\text{dBm} + 10\log(20.32) = 24.08 \text{ dBm} >24\text{dBm}.$
8. $11\text{dBm} + 10\log(20.55) = 24.13 \text{ dBm} >24\text{dBm}.$
9. $11\text{dBm} + 10\log(20.60) = 24.14 \text{ dBm} >24\text{dBm}.$

CHAIN 1

1. $4\text{dBm} + 10\log(20.29) = 17.07 \text{ dBm} >17\text{dBm}.$
2. $4\text{dBm} + 10\log(20.20) = 17.05 \text{ dBm} >17\text{dBm}.$
3. $4\text{dBm} + 10\log(20.30) = 17.07 \text{ dBm} >17\text{dBm}.$
4. $11\text{dBm} + 10\log(20.44) = 24.10 \text{ dBm} >24\text{dBm}.$
5. $11\text{dBm} + 10\log(20.27) = 24.07 \text{ dBm} >24\text{dBm}.$
6. $11\text{dBm} + 10\log(20.12) = 24.04 \text{ dBm} >24\text{dBm}.$
7. $11\text{dBm} + 10\log(20.19) = 24.05 \text{ dBm} >24\text{dBm}.$
8. $11\text{dBm} + 10\log(20.23) = 24.06 \text{ dBm} >24\text{dBm}.$
9. $11\text{dBm} + 10\log(20.29) = 24.07 \text{ dBm} >24\text{dBm}.$

**802.11n (40MHz)**

CHAN.	CHAN. FREQ. (MHz)	AVERAGE POWER (dBm)		TOTAL POWER (mW)	TOTAL POWER (dBm)	POWER LIMIT (dBm)	PASS / FAIL
		CHAIN 0	CHAIN 1				
38	5190	9.32	9.23	16.9	12.29	17	PASS
46	5230	9.21	8.93	16.2	12.08	17	PASS
54	5270	9.42	8.96	16.6	12.21	24	PASS
62	5310	9.33	8.93	16.4	12.14	24	PASS
102	5510	9.80	8.89	17.3	12.38	24	PASS
110	5550	9.72	8.67	16.7	12.24	24	PASS
134	5670	9.73	8.26	16.1	12.07	24	PASS

CHAIN 0

1. $4\text{dBm} + 10\log(45.93) = 20.62\text{ dBm} > 17\text{dBm}$.
2. $4\text{dBm} + 10\log(45.60) = 20.59\text{ dBm} > 17\text{dBm}$.
3. $11\text{dBm} + 10\log(45.17) = 27.55\text{ dBm} > 24\text{dBm}$.
4. $11\text{dBm} + 10\log(45.87) = 27.62\text{ dBm} > 24\text{dBm}$.
5. $11\text{dBm} + 10\log(46.10) = 27.64\text{ dBm} > 24\text{dBm}$.
6. $11\text{dBm} + 10\log(45.81) = 27.61\text{ dBm} > 24\text{dBm}$.
7. $11\text{dBm} + 10\log(46.32) = 27.66\text{ dBm} > 24\text{dBm}$.

CHAIN 1

1. $4\text{dBm} + 10\log(47.12) = 20.73\text{ dBm} > 17\text{dBm}$.
2. $4\text{dBm} + 10\log(46.19) = 20.65\text{ dBm} > 17\text{dBm}$.
3. $11\text{dBm} + 10\log(46.06) = 27.63\text{ dBm} > 24\text{dBm}$.
4. $11\text{dBm} + 10\log(45.84) = 27.61\text{ dBm} > 24\text{dBm}$.
5. $11\text{dBm} + 10\log(45.70) = 27.60\text{ dBm} > 24\text{dBm}$.
6. $11\text{dBm} + 10\log(46.56) = 27.68\text{ dBm} > 24\text{dBm}$.
7. $11\text{dBm} + 10\log(44.92) = 27.52\text{ dBm} > 24\text{dBm}$.

**26dB BANDWIDTH:**

CHANNEL	CHANNEL FREQUENCY (MHz)	26dBc BANDWIDTH (MHz)	PASS / FAIL
802.11a			
36	5180	19.98	PASS
40	5200	19.97	PASS
48	5240	20.15	PASS
52	5260	19.90	PASS
60	5300	20.05	PASS
64	5320	20.02	PASS
100	5500	20.09	PASS
116	5580	21.41	PASS
140	5700	29.36	PASS

CHANNEL	CHANNEL FREQUENCY (MHz)	26dBc BANDWIDTH (MHz)		PASS / FAIL
		CHAIN 0	CHAIN 1	
802.11n (20MHz)				
36	5180	20.87	20.29	PASS
40	5200	20.83	20.20	PASS
48	5240	20.95	20.30	PASS
52	5260	20.30	20.44	PASS
60	5300	20.66	20.27	PASS
64	5320	20.48	20.12	PASS
100	5500	20.32	20.19	PASS
116	5580	20.55	20.23	PASS
140	5700	20.60	20.29	PASS
802.11n (40MHz)				
38	5190	45.93	47.12	PASS
46	5230	45.60	46.19	PASS
54	5270	45.17	46.06	PASS
62	5310	45.87	45.84	PASS
102	5510	46.10	45.70	PASS
110	5550	45.81	46.56	PASS
134	5670	46.32	44.92	PASS



A D T

SPECTRUM PLOT OF WORST VALUE

802.11a

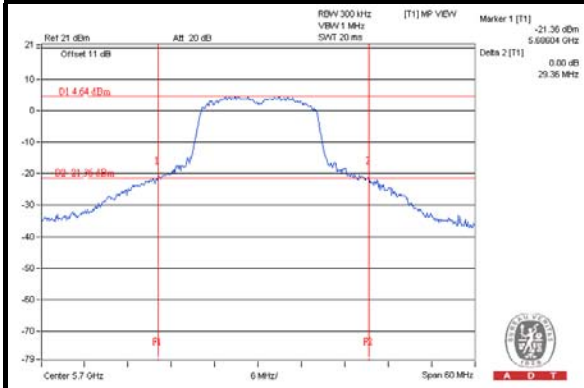

802.11n (20MHz)

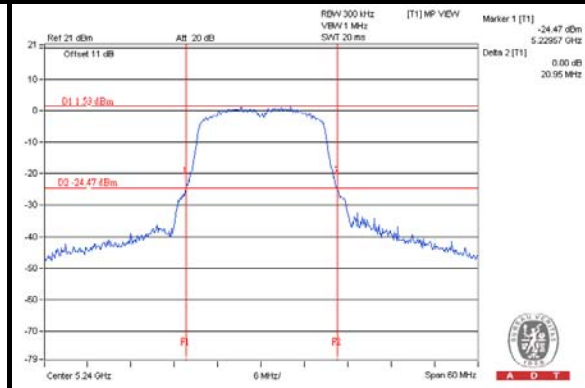

802.11n (40MHz)

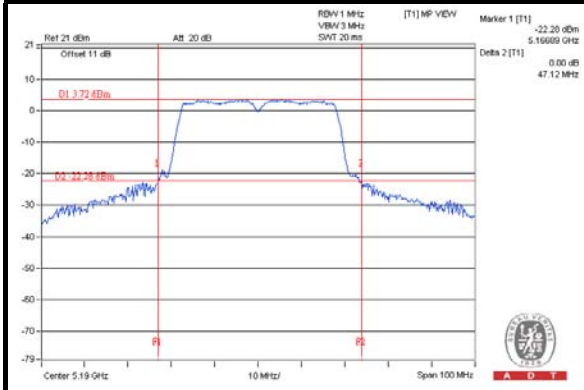

4.4 PEAK POWER SPECTRAL DENSITY MEASUREMENT

4.4.1 LIMITS OF PEAK POWER SPECTRAL DENSITY MEASUREMENT

FREQUENCY BAND	LIMIT
5.150 ~ 5.250GHz	4dBm
5.250 ~ 5.350GHz	11dBm
5.470 ~ 5.725GHz	11dBm

4.4.2 TEST SETUP

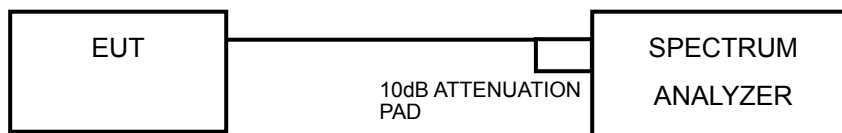

4.4.3 TEST INSTRUMENTS

Refer to section 4.1.3 to get information of above instrument.

4.4.4 TEST PROCEDURES

Using method SA-2

- 1) Set span to encompass the entire emission bandwidth (EBW) of the signal.
- 2) Set RBW = 30 KHz, Set VBW \geq 1 MHz, Detector = RMS
- 3) Set Channel power measure = 1MHz
- 4) Sweep time = auto, trigger set to "free run".
- 5) Trace average at least 100 traces in power averaging mode.
- 6) Record the max value and add $10 \log (1/\text{duty cycle})$

4.4.5 DEVIATION FROM TEST STANDARD

No deviation.

4.4.6 EUT OPERATING CONDITIONS

Same as 4.3.6.

4.4.7 TEST RESULTS

802.11a

CHANNEL	FREQUENCY (MHz)	PSD W/O DUTY FACTOR (dBm)	DUTY FACTOR	PSD WITH DUTY FACTOR (dBm)	MAXIMUM LIMIT (dBm)	PASS/FAIL
36	5180	0.20	0.23	0.43	4	PASS
40	5200	0.24	0.23	0.47	4	PASS
48	5240	0.12	0.23	0.35	4	PASS
52	5260	-0.01	0.23	0.22	11	PASS
60	5300	0.07	0.23	0.30	11	PASS
64	5320	-0.07	0.23	0.16	11	PASS
100	5500	-0.90	0.23	-0.67	11	PASS
116	5580	-0.44	0.23	-0.21	11	PASS
140	5700	-0.38	0.23	-0.15	11	PASS

NOTE: Refer to section 3.3 for duty cycle spectrum plot.

802.11n (20MHz)

CHAN.	CHAN. FREQ. (MHz)	PSD (dBm)		TOTAL PSD W/O DUTY FACTOR (dBm)	DUTY FACTOR	TOTAL PSD WITH DUTY FACTOR (dBm)	MAX. LIMIT (dBm)	PASS / FAIL
		CHAIN 0	CHAIN 1					
36	5180	-4.04	-3.60	-0.80	0.42	-0.38	4	PASS
40	5200	-4.32	-3.78	-1.03	0.42	-0.61	4	PASS
48	5240	-3.72	-4.07	-0.88	0.42	-0.46	4	PASS
52	5260	-3.86	-4.20	-1.02	0.42	-0.60	11	PASS
60	5300	-4.32	-5.53	-1.87	0.42	-1.45	11	PASS
64	5320	-4.32	-4.94	-1.61	0.42	-1.19	11	PASS
100	5500	-4.24	-5.47	-1.80	0.42	-1.38	11	PASS
116	5580	-3.65	-5.77	-1.57	0.42	-1.15	11	PASS
140	5700	-4.07	-5.77	-1.83	0.42	-1.41	11	PASS

NOTE:

1. Method a of power density measurement of KDB 662911 is using for calculating total power density. Total power density is summing entire spectra across corresponding frequency bins on the various outputs by computer.
2. Directional gain = $1.66\text{dBi} + 10\log(2) = 4.67\text{dBi} < 6\text{dBi}$, so the power spectral density limit is not reduced.
3. Refer to section 3.3 for duty cycle spectrum plot.

802.11n (40MHz)

CHAN.	CHAN. FREQ. (MHz)	PSD (dBm)		TOTAL PSD W/O DUTY FACTOR (dBm)	DUTY FACTOR	TOTAL PSD WITH DUTY FACTOR (dBm)	MAX. LIMIT (dBm)	PASS / FAIL
		CHAIN 0	CHAIN 1					
38	5190	-8.30	-7.71	-4.98	0.77	-4.21	4	PASS
46	5230	-8.35	-8.30	-5.31	0.77	-4.54	4	PASS
54	5270	-8.34	-8.65	-5.48	0.77	-4.71	11	PASS
62	5310	-8.09	-8.42	-5.24	0.77	-4.47	11	PASS
102	5510	-7.83	-8.87	-5.31	0.77	-4.54	11	PASS
110	5550	-7.32	-9.32	-5.20	0.77	-4.43	11	PASS
134	5670	-7.77	-9.75	-5.64	0.77	-4.87	11	PASS

NOTE:

1. Method a of power density measurement of KDB 662911 is using for calculating total power density. Total power density is summing entire spectra across corresponding frequency bins on the various outputs by computer.
2. Directional gain = $1.66\text{dBi} + 10\log(2) = 4.67\text{dBi} < 6\text{dBi}$, so the power spectral density limit is not reduced.
3. Refer to section 3.3 for duty cycle spectrum plot.

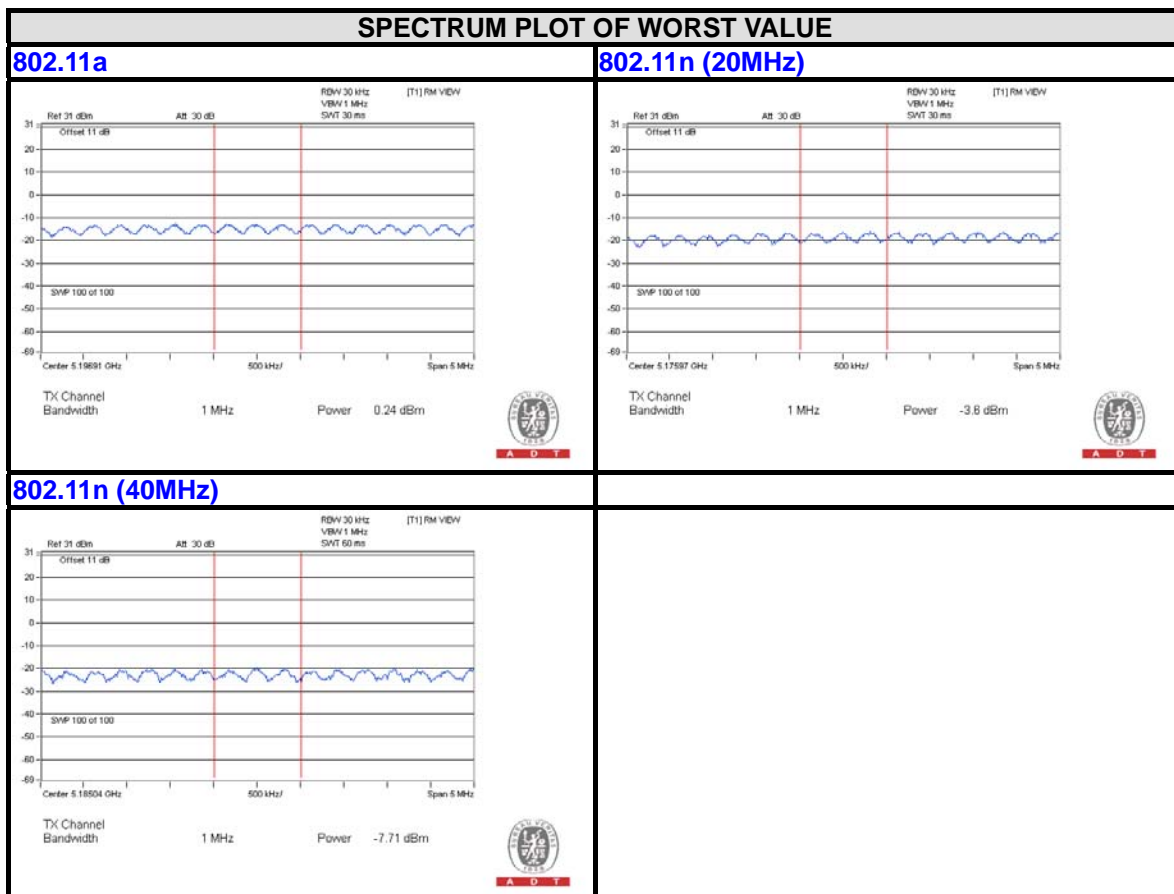

4.5 PEAK POWER EXCURSION MEASUREMENT

4.5.1 LIMITS OF PEAK POWER EXCURSION MEASUREMENT

Shall not exceed 13 dB.

4.5.2 TEST SETUP

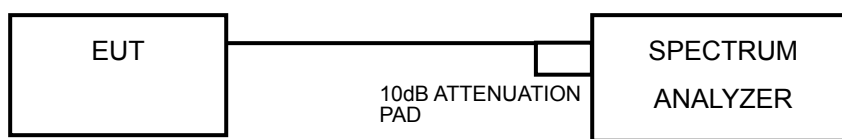

4.5.3 TEST INSTRUMENTS

Refer to section 4.1.3 to get information of above instrument.

4.5.4 TEST PROCEDURE

- 1) Set RBW = 1 MHz, VBW \geq 3 MHz, Detector = peak.
- 2) Trace mode = max-hold. Allow the sweeps to continue until the trace stabilizes.
- 3) Use the peak search function to find the peak of the spectrum.
- 4) Measure the PPSD.
- 5) Compute the ratio of the maximum of the peak-max-hold spectrum to the PPSD. Find the worst channel and modulation mode as above test procedure, and follow KDB 789033 D01 General UNII Test Procedures v01r03 and repeat step 1 to 5 for final testing of each modulation mode on a single channel (all modulation types) in a single operating band to compliance with the peak excursion requirement.

4.5.5 DEVIATION FROM TEST STANDARD

No deviation.

4.5.6 EUT OPERATING CONDITIONS

Same as 4.2.6

4.5.7 TEST RESULTS

MODULATION MODE	MODULATION TYPE	CHAN. FREQ. (MHz)	PEAK VALUE (dBm)	PPSD WITHOUT DUTY FACTOR (dBm)	PPSD WITH DUTY FACTOR (dBm)	PEAK EXCURSION (dB)	LIMIT (dB)	PASS /FAIL
802.11a	BPSK	5180	11.10	0.20	0.43	10.67	13	PASS
	QPSK		11.40	-0.18	-0.07	11.47	13	PASS
	16QAM		10.71	-0.39	-0.14	10.85	13	PASS
	64QAM		10.94	-0.64	-0.19	11.13	13	PASS
802.11n (20MHz)	BPSK	5180	6.82	-4.04	-3.62	10.44	13	PASS
	QPSK		6.85	-4.61	-4.13	10.98	13	PASS
	16QAM		6.34	-5.00	-4.39	10.73	13	PASS
	64QAM		6.51	-5.69	-4.91	11.42	13	PASS
802.11n (40MHz)	BPSK	5190	2.69	-8.30	-7.53	10.22	13	PASS
	QPSK		3.12	-8.71	-8.12	11.24	13	PASS
	16QAM		2.99	-9.00	-8.06	11.05	13	PASS
	64QAM		2.59	-9.36	-8.05	10.64	13	PASS

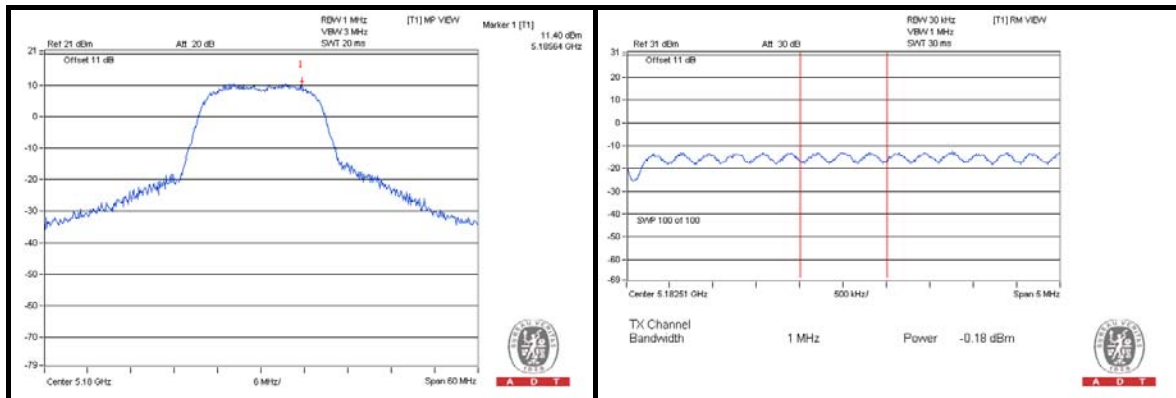

4.6 FREQUENCY STABILITY

4.6.1 LIMITS OF FREQUENCY STABILITY MEASUREMENT

The frequency of the carrier signal shall be maintained within band of operation

4.6.2 TEST SETUP

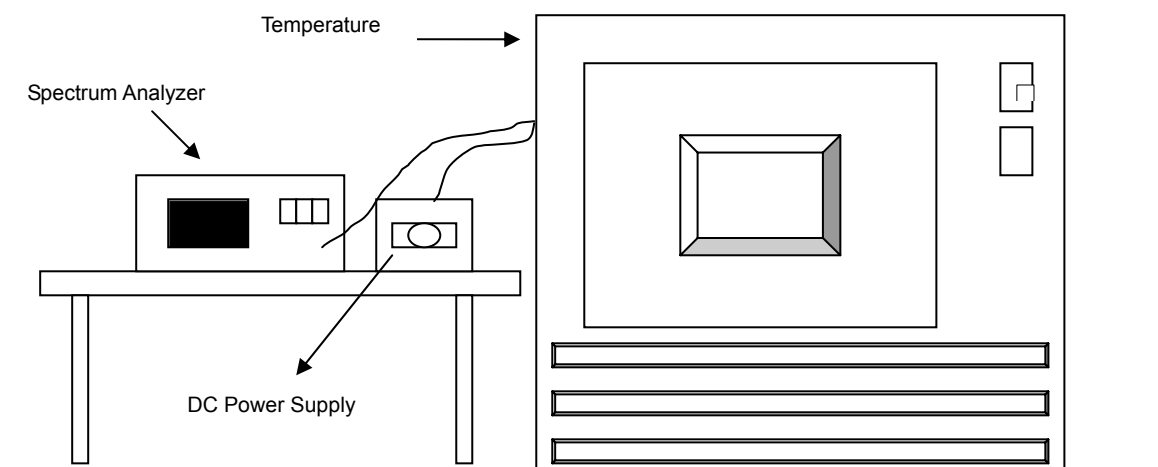

4.6.3 TEST INSTRUMENTS

Refer to section 4.1.3 to get information of above instrument.

4.6.4 TEST PROCEDURE

- a. The EUT was placed inside the environmental test chamber and powered by nominal DC voltage.
- b. Turn the EUT on and couple its output to a spectrum analyzer.
- c. Turn the EUT off and set the chamber to the highest temperature specified.
- d. Allow sufficient time (approximately 30 min) for the temperature of the chamber to stabilize, turn the EUT on and measure the operating frequency after 2, 5, and 10 minutes.
- e. Repeat step 2 and 3 with the temperature chamber set to the lowest temperature.
- f. The test chamber was allowed to stabilize at +20 degree C for a minimum of 30 minutes. The supply voltage was then adjusted on the EUT from 85% to 115% and the frequency record.

4.6.5 DEVIATION FROM TEST STANDARD

No deviation.

4.6.6 EUT OPERATING CONDITION

Set the EUT transmit at un-modulation mode to test frequency stability.



4.6.7 TEST RESULTS

FREQUENCY STABILITY VERSUS TEMP.									
OPERATING FREQUENCY: 5180MHz									
TEMP. (°C)	POWER SUPPLY (Vac)	0 MINUTE		2 MINUTE		5 MINUTE		10 MINUTE	
		Measured Frequency (MHz)	Frequency Drift (ppm)	Measured Frequency (MHz)	Frequency Drift (ppm)	Measured Frequency (MHz)	Frequency Drift (ppm)	Measured Frequency (MHz)	Frequency Drift (ppm)
50	120.0	5180.043159	8.3318978	5180.042937	8.2890461	5180.043013	8.3037482	5180.043035	8.3078249
40	120.0	5180.042656	8.2347587	5180.042781	8.2589023	5180.042763	8.2554308	5180.042983	8.2978669
30	120.0	5180.042676	8.2385456	5180.043014	8.3038435	5180.042646	8.2329081	5180.043017	8.3043595
20	120.0	5180.042674	8.2383143	5180.042494	8.2034736	5180.042673	8.2381025	5180.042695	8.2423648
10	120.0	5180.042748	8.2524945	5180.042947	8.2909343	5180.042818	8.2660133	5180.042535	8.2112937
0	120.0	5180.043106	8.3215788	5180.043009	8.3028475	5180.043034	8.3076369	5180.042887	8.2792531
-10	120.0	5180.043389	8.3762409	5180.042954	8.2922245	5180.043136	8.3273950	5180.042922	8.2860215
-20	120.0	5180.042826	8.2675483	5180.043114	8.3231553	5180.043176	8.3351142	5180.042905	8.2828130

FREQUENCY STABILITY VERSUS VOLTAGE									
OPERATING FREQUENCY: 5180MHz									
TEMP. (°C)	POWER SUPPLY (Vac)	0 MINUTE		2 MINUTE		5 MINUTE		10 MINUTE	
		Measured Frequency (MHz)	Frequency Drift (ppm)	Measured Frequency (MHz)	Frequency Drift (ppm)	Measured Frequency (MHz)	Frequency Drift (ppm)	Measured Frequency (MHz)	Frequency Drift (ppm)
20	138.0	5180.043227	8.3448946	5180.04297	8.2954098	5180.042871	8.2762599	5180.042844	8.2709812
	120.0	5180.042674	8.2383143	5180.042494	8.2034736	5180.042673	8.2381025	5180.042695	8.2423648
	102.0	5180.042246	8.1555593	5180.042041	8.1161141	5180.042499	8.2044704	5180.042357	8.1770567

5. PHOTOGRAPHS OF THE TEST CONFIGURATION

Please refer to the attached file (Test Setup Photo).



6. INFORMATION ON THE TESTING LABORATORIES

We, Bureau Veritas Consumer Products Services (H.K.) Ltd., Taoyuan Branch, were founded in 1988 to provide our best service in EMC, Radio, Telecom and Safety consultation. Our laboratories are accredited and approved according to ISO/IEC 17025.

If you have any comments, please feel free to contact us at the following:

Linko EMC/RF Lab:
Tel: 886-2-26052180
Fax: 886-2-26051924

Hsin Chu EMC/RF Lab:
Tel: 886-3-5935343
Fax: 886-3-5935342

Hwa Ya EMC/RF/Safety Telecom Lab:
Tel: 886-3-3183232
Fax: 886-3-3270892

Email: service.adt@tw.bureauveritas.com

Web Site: www.bureauveritas-adt.com

The address and road map of all our labs can be found in our web site also.

7. APPENDIX A – MODIFICATIONS RECORDERS FOR ENGINEERING CHANGES TO THE EUT BY THE LAB

No modifications were made to the EUT by the lab during the test.

---END---