

## **7.7. Band-edge Compliance Measurement**

### **7.7.1. Test Limit**

The maximum permissible emission level is 20dBc. Any emissions were lying outside of the emission bandwidth and in authorized band edges to a field strength limit specified in Section 15.209 of the Title 47 CFR.

### **7.7.2. Test Procedure Used**

ANSI C63.10-2013 - Section 7.8.6

### **7.7.3. Test Setting**

1. Span = wide enough to capture the peak level of the emission operating on the channel closest to the band edge, as well as any modulation products which fall outside of the authorized band of operation.
2. RBW  $\geq$  1% of spectrum analyzer display span
3. VBW  $\geq$  RBW
4. Detector = peak
5. Sweep time = auto couple
6. Trace mode = max hold
7. Trace was allowed to stabilize

Allow the trace to stabilize. Set the marker on the emission at the band edge, or on the highest modulation product outside of the band, if this level is greater than that at the band edge. Enable the marker-delta function, then use the marker-to-peak function to move the marker to the peak of the in-band emission.

### 7.7.4. Test Setup

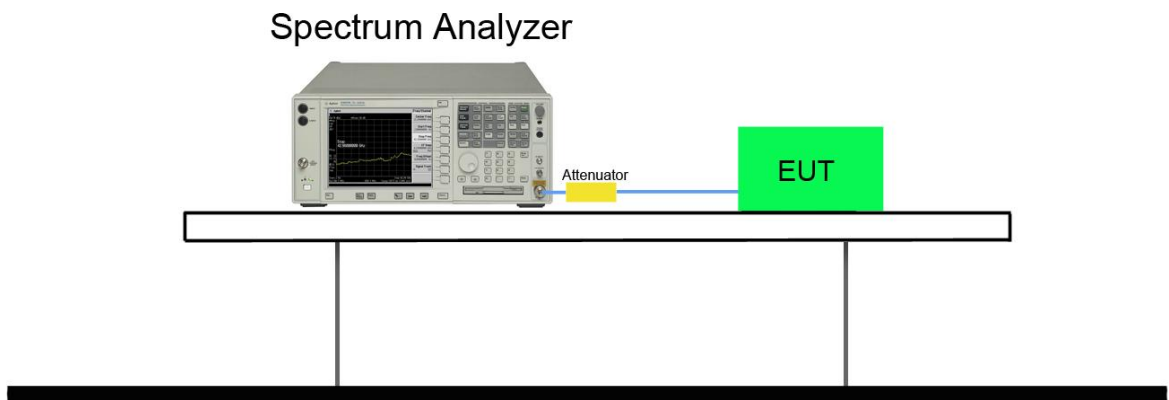

### 7.7.5. Test Result

Test Mode	Channel No.	Frequency (MHz)	Limit	Result
DH5	00	2402	20dBc	Pass
DH5	78	2480	20dBc	Pass
2DH5	00	2402	20dBc	Pass
2DH5	78	2480	20dBc	Pass
3DH5	00	2402	20dBc	Pass
3DH5	78	2480	20dBc	Pass

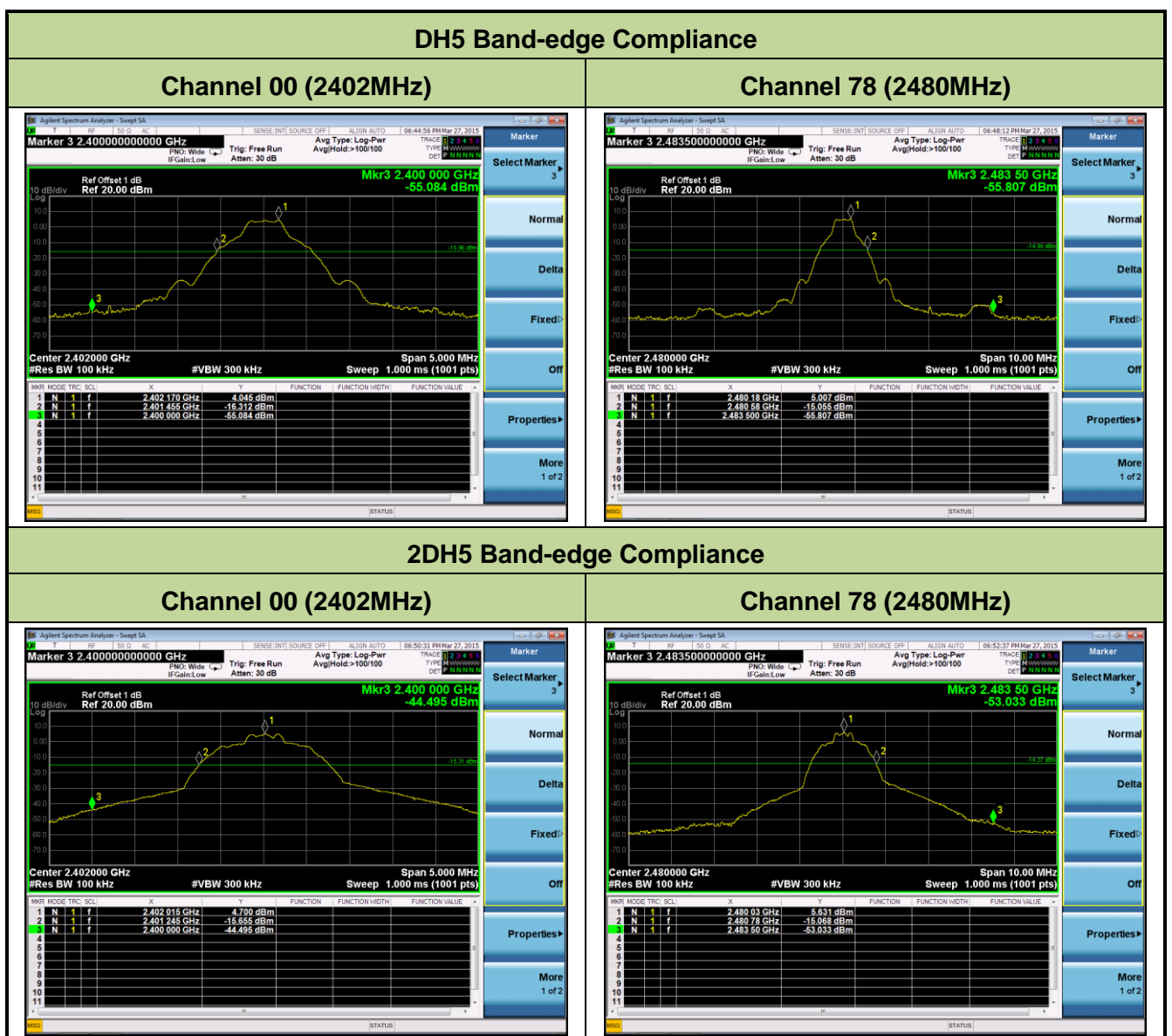

### 3DH5 Band-edge Compliance

Channel 00 (2402MHz)

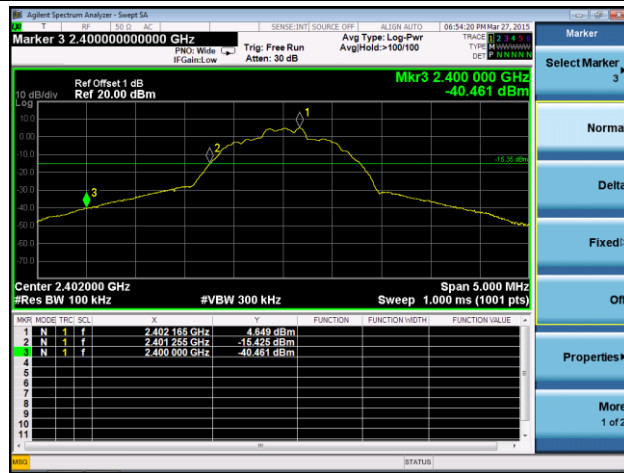

Channel 78 (2480MHz)

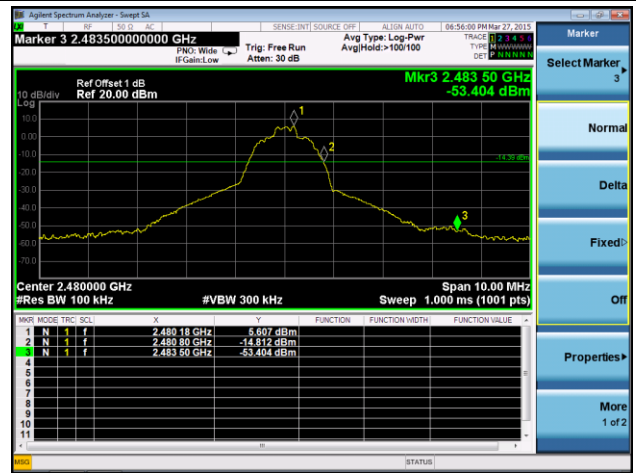

### DH5 Operation Frequency Range of 20dB Bandwidth within Hopping Mode

Channel 00 (2402MHz)

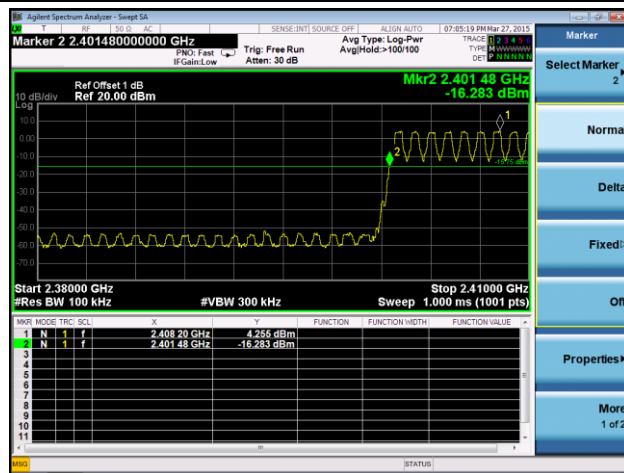

Channel 78 (2480MHz)

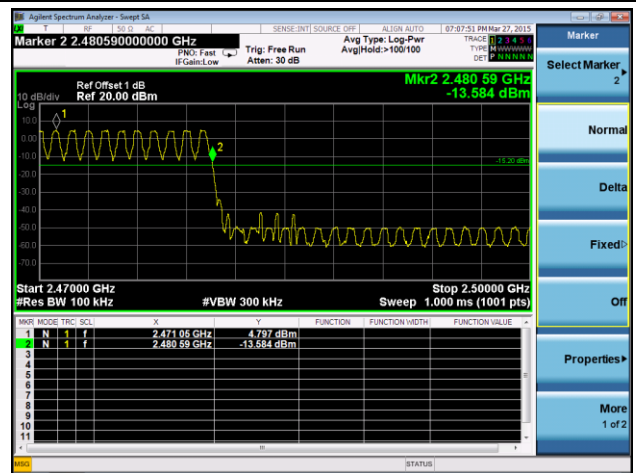

### 2DH5 Operation Frequency Range of 20dB Bandwidth within Hopping Mode

Channel 00 (2402MHz)

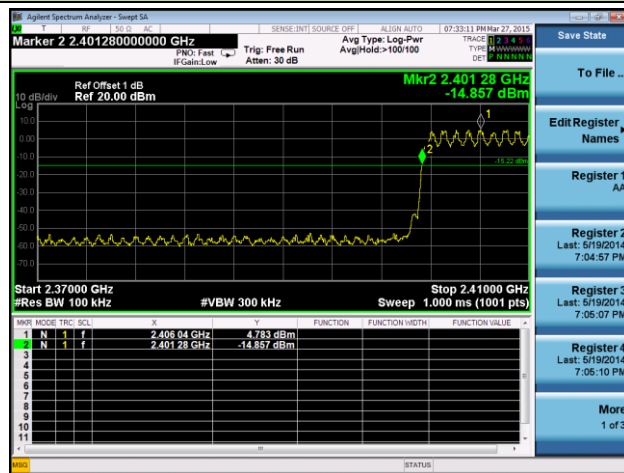

Channel 78 (2480MHz)

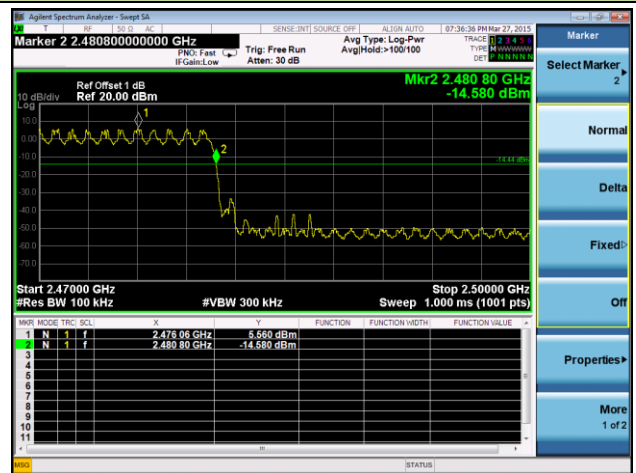

### 3DH5 Operation Frequency Range of 20dB Bandwidth within Hopping Mode

**Channel 00 (2402MHz)**

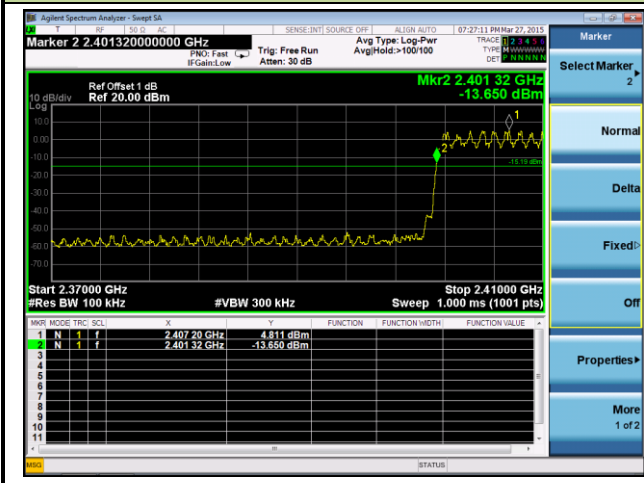

**Channel 78 (2480MHz)**

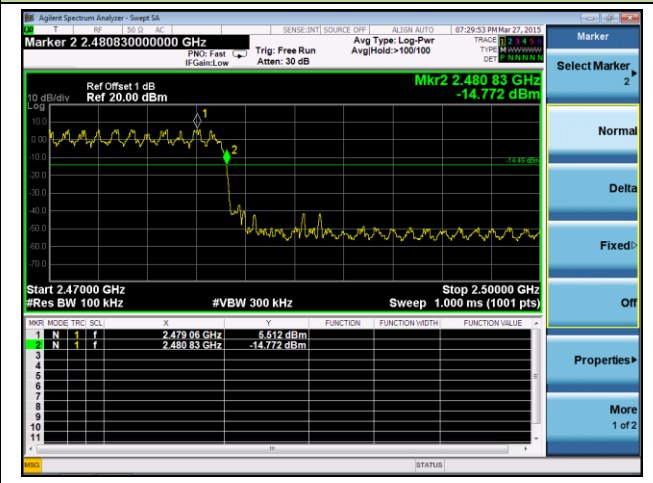

## **7.8. Conducted Spurious Emissions Measurement**

### **7.8.1. Test Limit**

In any 100 kHz bandwidth outside the frequency band in which the spread spectrum or digitally modulated intentional radiator is operating, the radio frequency power that is produced by the intentional radiator shall be at least 20 dB below that in the 100 kHz bandwidth within the band that contains the highest level of the desired power, based on either an RF conducted or a radiated measurement, provided the transmitter demonstrates compliance with the peak conducted or a radiated measurement, provided the transmitter demonstrates compliance with the peak conducted power limits. If the transmitter complies with the conducted power limits based on the use of RMS averaging over a time interval, the attenuation required under this paragraph shall be 30 dB instead of 20 dB.

### **7.8.2. Test Procedure Used**

ANSI C63.10-2013 - Section 7.8.8

### **7.8.3. Test Setting**

1. Span = wide enough to capture the peak level of the in-band emission and all spurious emissions (e.g., harmonics) from the lowest frequency generated in the EUT up through the 10<sup>th</sup> harmonic. Typically, several plots are required to cover this entire span.
2. RBW = 100 KHz
3. VBW  $\geq$  RBW
4. Detector = peak
5. Sweep time = auto couple
6. Trace mode = max hold
7. Trace was allowed to stabilize

Set the marker on the peak of any spurious emission recorded. The level displayed must comply with the limit specified in this section.

### 7.8.4. Test Setup

Spectrum Analyzer

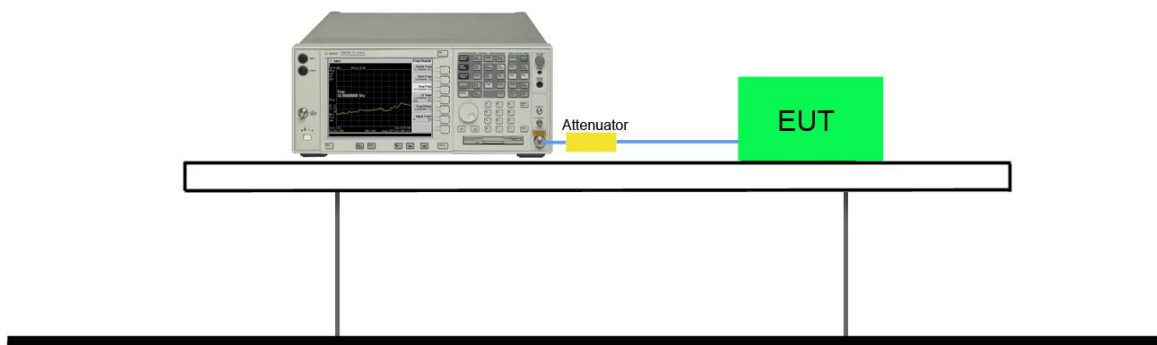

### 7.8.5. Test Result

Test Mode	Channel No.	Frequency (MHz)	Limit (MHz)	Result
DH5	00	2402	20dBc	Pass
DH5	39	2441	20dBc	Pass
DH5	78	2480	20dBc	Pass
2DH5	00	2402	20dBc	Pass
2DH5	39	2441	20dBc	Pass
2DH5	78	2480	20dBc	Pass
3DH5	00	2402	20dBc	Pass
3DH5	39	2441	20dBc	Pass
3DH5	78	2480	20dBc	Pass

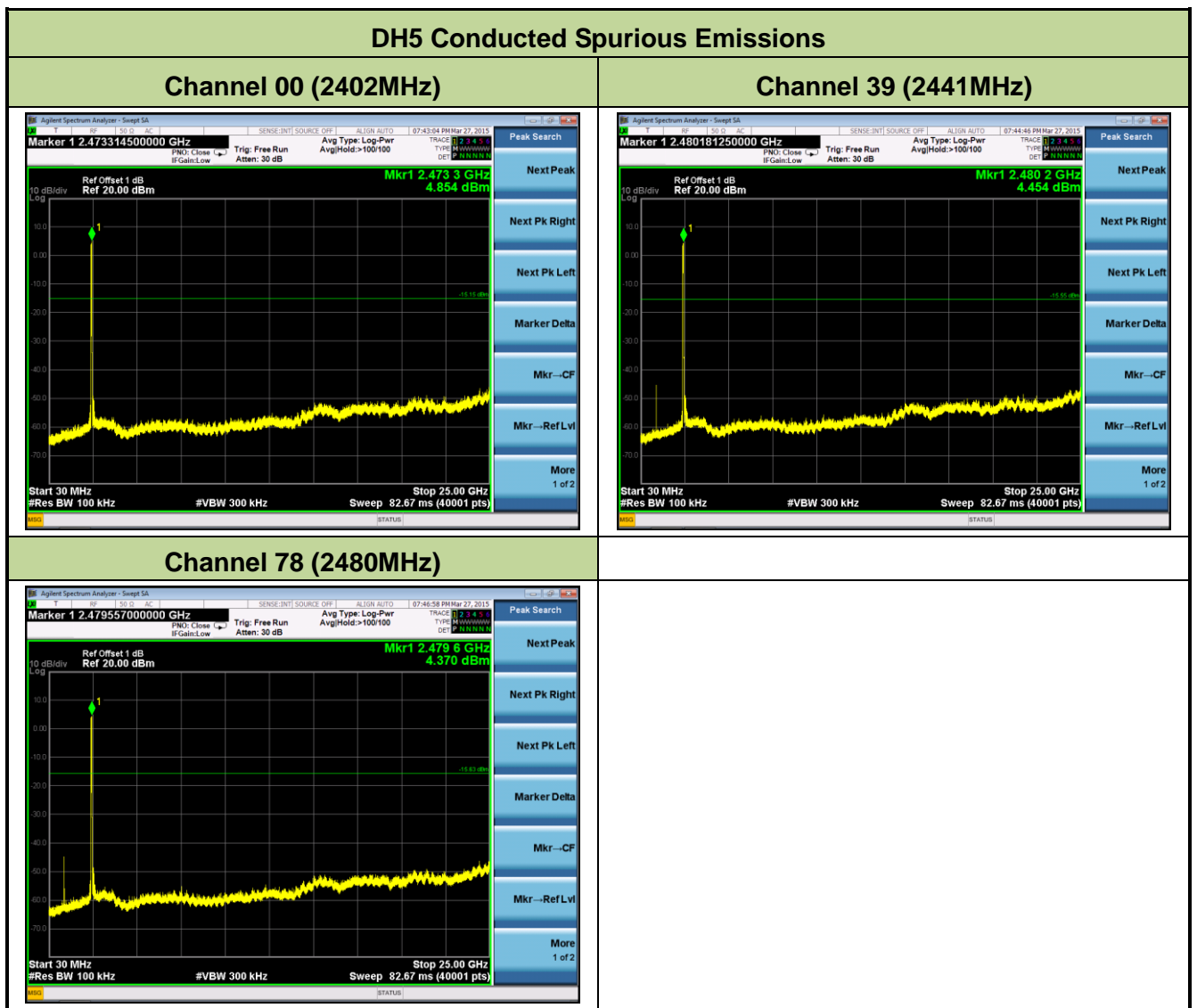



### 2DH5 Conducted Spurious Emissions

**Channel 00 (2402MHz)**

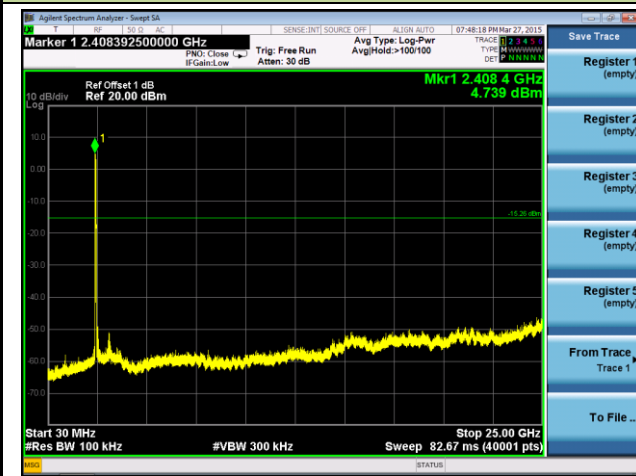

**Channel 39 (2441MHz)**

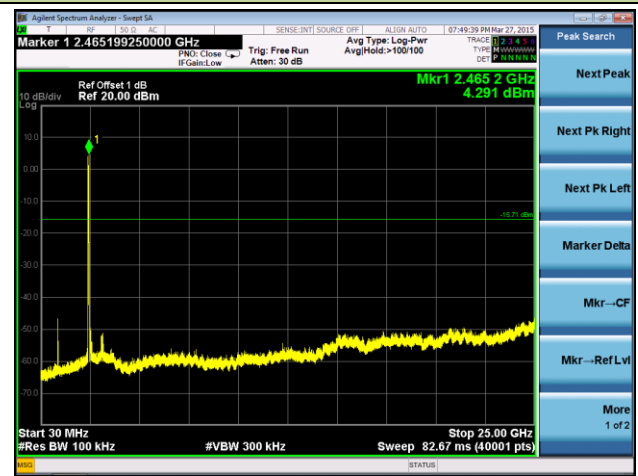

**Channel 78 (2480MHz)**

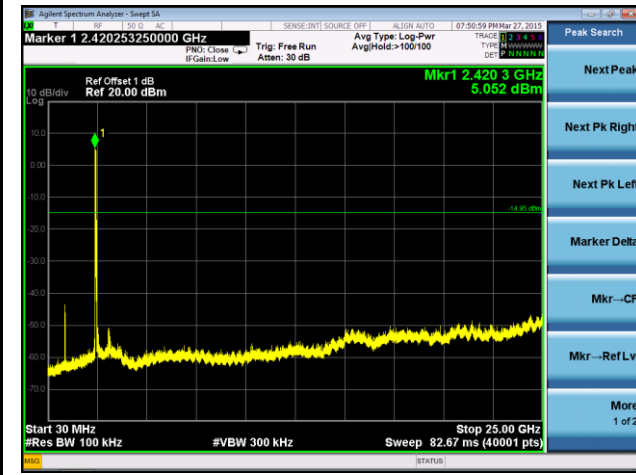

### 3DH5 Conducted Spurious Emissions

**Channel 00 (2402MHz)**

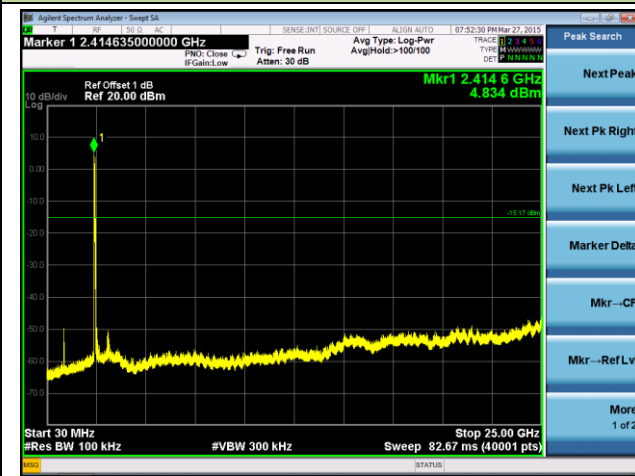

**Channel 39 (2441MHz)**

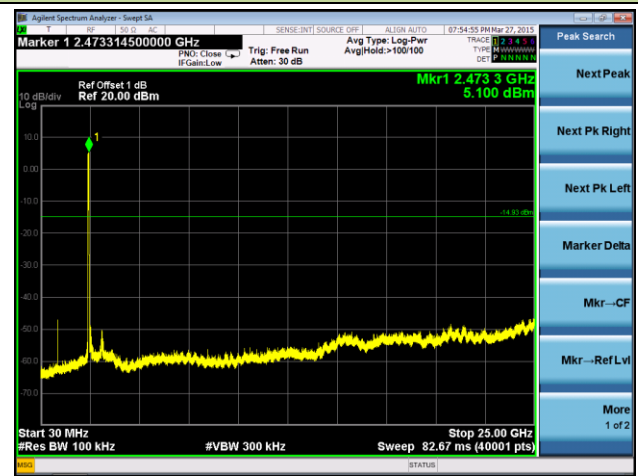

**Channel 78 (2480MHz)**

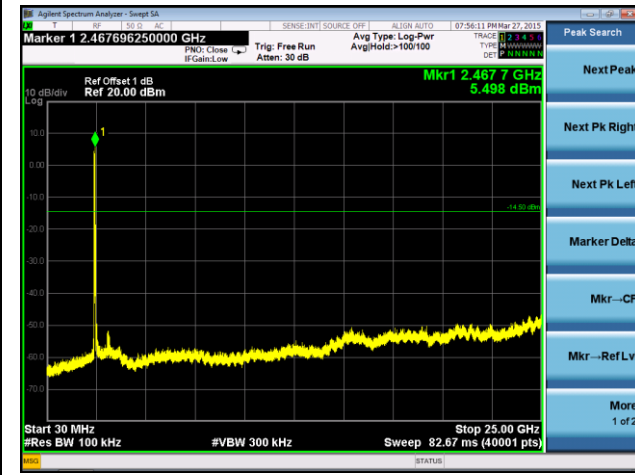

## 7.9. Radiated Spurious Emission Measurement

### 7.9.1. Test Limit

All out of band emissions appearing in a restricted band as specified in Section 15.205 of the Title 47 CFR must not exceed the limits shown in Table per Section 15.209.

FCC Part 15 Subpart C Paragraph 15.209		
Frequency [MHz]	Field Strength [V/m]	Measured Distance [Meters]
0.009 - 0.490	2400/F (kHz)	300
0.490 - 1.705	24000/F (kHz)	30
1.705 – 30	30	30
30 – 88	100	3
88 – 216	150	3
216 – 960	200	3
Above 960	500	3

### 7.9.2. Test Procedure Used

ANSI C63.10-2013 - Section 6.10.5

### 7.9.3. Test Setting

#### **Peak Field Strength Measurements**

1. Analyzer center frequency was set to the frequency of the radiated spurious emission of interest
2. RBW = as specified in Table 1
3. VBW = 3 \* RBW
4. Detector = peak
5. Sweep time = auto couple
6. Trace mode = max hold
7. Trace was allowed to stabilize

**Table 1 - RBW as a function of frequency**

Frequency	RBW
9 ~ 150 kHz	200 ~ 300 Hz
0.15 ~ 30 MHz	9 ~ 10 kHz
30 ~ 1000 MHz	100 ~ 120 kHz
> 1000 MHz	1 MHz

**Average Field Strength Measurements**

1. Analyzer center frequency was set to the frequency of the radiated spurious emission of interest
2. RBW = 1MHz
3. VBW  $\geq$  1/T
4. De As an alternative, the instrument may be set to linear detector mode. Ensure that video filtering is applied in linear voltage domain (rather than in a log or dB domain). Some instruments require linear display mode in order to accomplish this. Others have a setting for Average-VBW Type, which can be set to "Voltage" regardless of the display mode
5. Detector = Peak
6. Sweep time = auto
7. Trace mode = max hold
8. Allow max hold to run for at least 50 times (1/duty cycle) traces

### 7.9.4. Test Setup

#### 9kHz ~ 30MHz Test Setup:

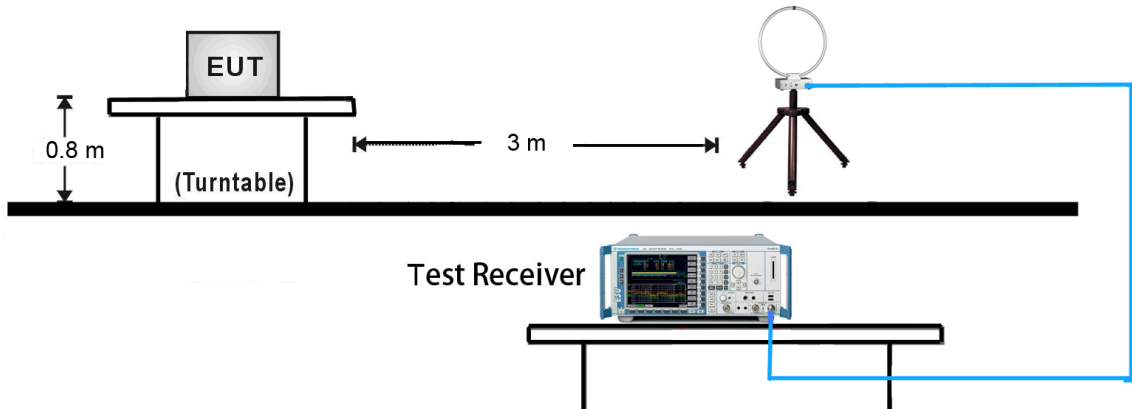

#### 30MHz ~ 1GHz Test Setup:

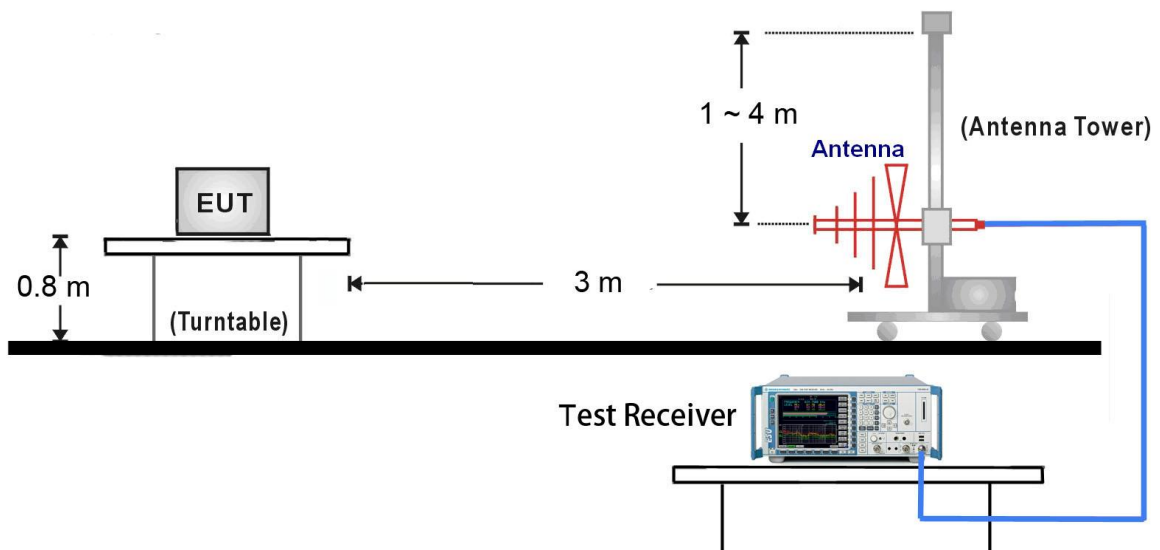

1GHz ~ 25GHz Test Setup:

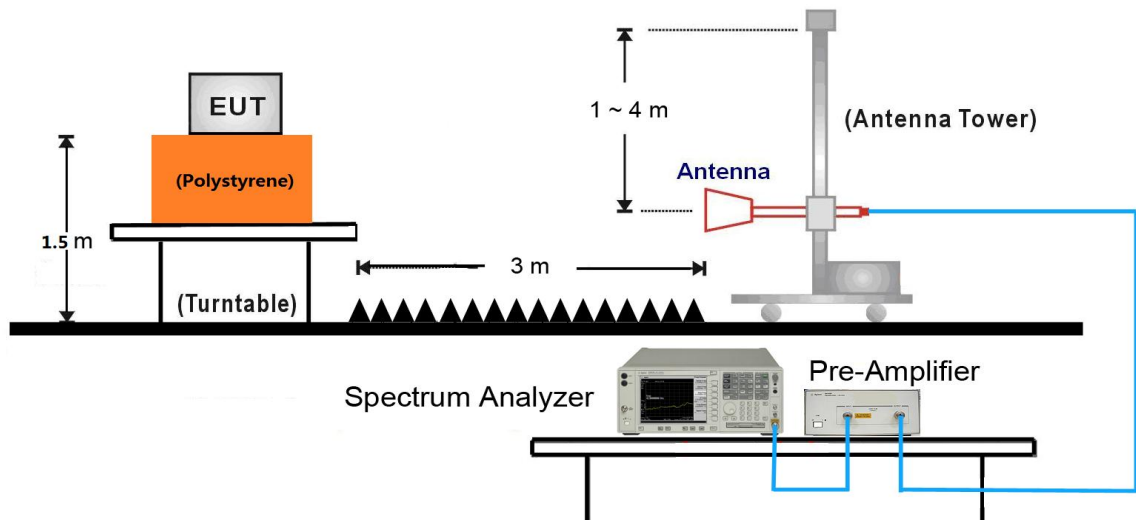

**7.9.5. Test Result**

Test Mode:	DH5	Test Site:	AC1
Test Channel:	00	Test Engineer:	Roy Cheng
Remark:	1. Average measurement was not performed if peak level lower than average limit. 2. Other frequency was 20dB below limit line within 1-18GHz, there is not show in the report.		

Mark	Frequency (MHz)	Reading Level (dB $\mu$ V)	Factor (dB)	Measure Level (dB $\mu$ V/m)	Limit (dB $\mu$ V/m)	Margin (dB)	Detector	Polarization
	4872.3	36.6	2.7	39.3	74.0	-34.7	Peak	Horizontal
*	6841.8	36.0	6.3	42.3	76.7	-34.4	Peak	Horizontal
	8275.8	36.2	8.1	44.3	74.0	-29.7	Peak	Horizontal
*	9657.6	34.9	11.0	45.9	76.7	-30.8	Peak	Horizontal
	4875.6	36.2	2.7	38.9	74.0	-35.1	Peak	Vertical
*	6253.6	35.7	4.7	40.4	76.6	-36.2	Peak	Vertical
	8273.5	35.2	8.1	43.3	74.0	-30.7	Peak	Vertical
*	9471.0	35.1	10.5	45.6	76.7	-31.1	Peak	Vertical

Note 1: "\*" is not in restricted band, its limit is 20dBc of the fundamental emission level (96.7dB $\mu$ V/m).

Note 2: Measure Level (dB $\mu$ V/m) = Reading Level (dB $\mu$ V) + Factor (dB)

Factor (dB) = Cable Loss (dB) + Antenna Factor (dB/m) - Pre\_Amplifier Gain (dB)

Test Mode:	DH5	Test Site:	AC1
Test Channel:	39	Test Engineer:	Roy Cheng
Remark:	1. Average measurement was not performed if peak level lower than average limit. 2. Other frequency was 20dB below limit line within 1-18GHz, there is not show in the report.		

Mark	Frequency (MHz)	Reading Level (dB $\mu$ V)	Factor (dB)	Measure Level (dB $\mu$ V/m)	Limit (dB $\mu$ V/m)	Margin (dB)	Detector	Polarization
	4854.8	36.5	2.7	39.2	74.0	-34.8	Peak	Horizontal
*	6349.2	35.2	5.1	40.3	77.5	-37.2	Peak	Horizontal
	8465.8	34.1	8.2	42.3	74.0	-31.7	Peak	Horizontal
*	9416.8	34.9	10.6	45.5	77.5	-32.0	Peak	Horizontal
	4872.5	36.2	2.7	38.9	74.0	-35.1	Peak	Vertical
*	6253.4	34.8	4.7	39.5	77.5	-38.0	Peak	Vertical
	8470.1	34.1	8.2	42.3	74.0	-31.7	Peak	Vertical
*	9471.5	34.8	10.5	45.3	77.5	-32.2	Peak	Vertical

Note 1: "\*" is not in restricted band, its limit is 20dBc of the fundamental emission level (97.5dB $\mu$ V/m).

Note 2: Measure Level (dB $\mu$ V/m) = Reading Level (dB $\mu$ V) + Factor (dB)

Factor (dB) = Cable Loss (dB) + Antenna Factor (dB/m) - Pre\_Amplifier Gain (dB)



Test Mode:	DH5	Test Site:	AC1
Test Channel:	78	Test Engineer:	Roy Cheng
Remark:	1. Average measurement was not performed if peak level lower than average limit. 2. Other frequency was 20dB below limit line within 1-18GHz, there is not show in the report.		

Mark	Frequency (MHz)	Reading Level (dB $\mu$ V)	Factor (dB)	Measure Level (dB $\mu$ V/m)	Limit (dB $\mu$ V/m)	Margin (dB)	Detector	Polarization
	4871.4	36.1	2.7	38.8	74.0	-35.2	Peak	Horizontal
*	6583.4	34.0	6.0	40.0	78.9	-38.9	Peak	Horizontal
	8347.9	34.2	8.0	42.2	74.0	-31.8	Peak	Horizontal
*	9682.7	33.6	10.9	44.5	78.9	-34.4	Peak	Horizontal
	4870.2	36.2	2.7	38.9	74.0	-35.1	Peak	Vertical
*	6253.7	34.4	4.7	39.1	78.9	-39.8	Peak	Vertical
	8473.4	34.4	8.3	42.7	74.0	-31.3	Peak	Vertical
*	9655.4	33.7	11.0	44.7	78.9	-34.2	Peak	Vertical

Note 1: "\*" is not in restricted band, its limit is 20dBc of the fundamental emission level (98.9dB $\mu$ V/m).

Note 2: Measure Level (dB $\mu$ V/m) = Reading Level (dB $\mu$ V) + Factor (dB)

Factor (dB) = Cable Loss (dB) + Antenna Factor (dB/m) - Pre\_Amplifier Gain (dB)

Test Mode:	2DH5	Test Site:	AC1
Test Channel:	00	Test Engineer:	Roy Cheng
Remark:	1. Average measurement was not performed if peak level lower than average limit. 2. Other frequency was 20dB below limit line within 1-18GHz, there is not show in the report.		

Mark	Frequency (MHz)	Reading Level (dB $\mu$ V)	Factor (dB)	Measure Level (dB $\mu$ V/m)	Limit (dB $\mu$ V/m)	Margin (dB)	Detector	Polarization
	4872.3	35.4	2.7	38.1	74.0	-35.9	Peak	Horizontal
*	6589.7	34.1	6.0	40.1	77.5	-37.4	Peak	Horizontal
	8471.7	33.9	8.2	42.1	74.0	-31.9	Peak	Horizontal
*	9470.3	33.9	10.5	44.4	77.5	-33.1	Peak	Horizontal
	4879.5	35.2	2.7	37.9	74.0	-36.1	Peak	Vertical
*	6234.3	35.1	4.7	39.8	77.5	-37.7	Peak	Vertical
	8371.9	34.0	8.0	42.0	74.0	-32.0	Peak	Vertical
*	9415.7	33.9	10.6	44.5	77.5	-33.0	Peak	Vertical

Note 1: "\*" is not in restricted band, its limit is 20dBc of the fundamental emission level (97.5dB $\mu$ V/m).

Note 2: Measure Level (dB $\mu$ V/m) = Reading Level (dB $\mu$ V) + Factor (dB)

Factor (dB) = Cable Loss (dB) + Antenna Factor (dB/m) - Pre\_Amplifier Gain (dB)

Test Mode:	2DH5	Test Site:	AC1
Test Channel:	39	Test Engineer:	Roy Cheng
Remark:	1. Average measurement was not performed if peak level lower than average limit. 2. Other frequency was 20dB below limit line within 1-18GHz, there is not show in the report.		

Mark	Frequency (MHz)	Reading Level (dBμV)	Factor (dB)	Measure Level (dBμV/m)	Limit (dBμV/m)	Margin (dB)	Detector	Polarization
	4852.6	35.3	2.7	38.0	74.0	-36.0	Peak	Horizontal
*	6258.4	34.8	4.8	39.6	78.7	-39.1	Peak	Horizontal
	8326.8	34.3	8.0	42.3	74.0	-31.7	Peak	Horizontal
*	9471.1	34.2	10.5	44.7	78.7	-34.0	Peak	Horizontal
	4816.7	35.4	2.7	38.1	74.0	-35.9	Peak	Vertical
*	6253.8	34.4	4.7	39.1	78.7	-39.6	Peak	Vertical
	8641.9	35.2	8.8	44.0	74.0	-30.0	Peak	Vertical
*	9473.6	34.2	10.5	44.7	78.7	-34.0	Peak	Vertical

Note 1: "\*" is not in restricted band, its limit is 20dBc of the fundamental emission level (98.7dBμV/m).

Note 2: Measure Level (dBμV/m) = Reading Level (dBμV) + Factor (dB)

Factor (dB) = Cable Loss (dB) + Antenna Factor (dB/m) - Pre\_Amplifier Gain (dB)

Test Mode:	2DH5	Test Site:	AC1
Test Channel:	78	Test Engineer:	Roy Cheng
Remark:	1. Average measurement was not performed if peak level lower than average limit. 2. Other frequency was 20dB below limit line within 1-18GHz, there is not show in the report.		

Mark	Frequency (MHz)	Reading Level (dBμV)	Factor (dB)	Measure Level (dBμV/m)	Limit (dBμV/m)	Margin (dB)	Detector	Polarization
	4923.4	36.3	2.8	39.1	74.0	-34.9	Peak	Horizontal
*	6852.5	35.0	6.3	41.3	79.7	-38.4	Peak	Horizontal
	8472.4	34.1	8.2	42.3	74.0	-31.7	Peak	Horizontal
*	9663.3	34.2	10.9	45.1	79.7	-34.6	Peak	Horizontal
	4955.2	35.7	2.9	38.6	74.0	-35.4	Peak	Vertical
*	6874.9	34.6	6.4	41.0	79.7	-38.7	Peak	Vertical
	8470.6	34.3	8.2	42.5	74.0	-31.5	Peak	Vertical
*	9357.8	34.5	10.5	45.0	79.7	-34.7	Peak	Vertical

Note 1: "\*" is not in restricted band, its limit is 20dBc of the fundamental emission level (99.7dBμV/m).

Note 2: Measure Level (dBμV/m) = Reading Level (dBμV) + Factor (dB)

Factor (dB) = Cable Loss (dB) + Antenna Factor (dB/m) - Pre\_Amplifier Gain (dB)

Test Mode:	3DH5	Test Site:	AC1
Test Channel:	00	Test Engineer:	Roy Cheng
Remark:	1. Average measurement was not performed if peak level lower than average limit. 2. Other frequency was 20dB below limit line within 1-18GHz, there is not show in the report.		

Mark	Frequency (MHz)	Reading Level (dB $\mu$ V)	Factor (dB)	Measure Level (dB $\mu$ V/m)	Limit (dB $\mu$ V/m)	Margin (dB)	Detector	Polarization
	4985.9	35.1	3.0	38.1	74.0	-35.9	Peak	Horizontal
*	6253.6	34.8	4.7	39.5	80.1	-40.6	Peak	Horizontal
	8347.2	33.7	8.0	41.7	74.0	-32.3	Peak	Horizontal
*	9471.7	34.7	10.5	45.2	80.1	-34.9	Peak	Horizontal
	4952.4	35.5	2.9	38.4	74.0	-35.6	Peak	Vertical
*	6852.4	35.3	6.3	41.6	80.1	-38.5	Peak	Vertical
	8370.0	35.0	8.0	43.0	74.0	-31.0	Peak	Vertical
*	9688.8	34.0	10.9	44.9	80.1	-35.2	Peak	Vertical

Note 1: "\*" is not in restricted band, its limit is 20dBc of the fundamental emission level (100.1dB $\mu$ V/m).

Note 2: Measure Level (dB $\mu$ V/m) = Reading Level (dB $\mu$ V) + Factor (dB)

Factor (dB) = Cable Loss (dB) + Antenna Factor (dB/m) - Pre\_Amplifier Gain (dB)

Test Mode:	3DH5	Test Site:	AC1
Test Channel:	39	Test Engineer:	Roy Cheng
Remark:	1. Average measurement was not performed if peak level lower than average limit. 2. Other frequency was 20dB below limit line within 1-18GHz, there is not show in the report.		

Mark	Frequency (MHz)	Reading Level (dB $\mu$ V)	Factor (dB)	Measure Level (dB $\mu$ V/m)	Limit (dB $\mu$ V/m)	Margin (dB)	Detector	Polarization
	4987.1	36.1	3.0	39.1	74.0	-34.912	Peak	Horizontal
*	6841.2	36.0	6.3	42.3	79.6	-31.684	Peak	Horizontal
	8326.7	35.5	8.0	43.5	74.0	-30.448	Peak	Horizontal
*	9622.1	35.3	10.9	46.2	79.6	-27.761	Peak	Horizontal
	4852.7	35.9	2.7	38.6	74.0	-35.464	Peak	Vertical
*	6553.3	35.4	6.0	41.4	79.6	-32.656	Peak	Vertical
	8326.5	34.5	8.0	42.5	74.0	-31.498	Peak	Vertical
*	9622.0	34.9	10.9	45.8	79.6	-28.107	Peak	Vertical

Note 1: "\*" is not in restricted band, its limit is 20dBc of the fundamental emission level (99.6dB $\mu$ V/m).

Note 2: Measure Level (dB $\mu$ V/m) = Reading Level (dB $\mu$ V) + Factor (dB)

Factor (dB) = Cable Loss (dB) + Antenna Factor (dB/m) - Pre\_Amplifier Gain (dB)

Test Mode:	3DH5	Test Site:	AC1
Test Channel:	78	Test Engineer:	Roy Cheng
Remark:	1. Average measurement was not performed if peak level lower than average limit. 2. Other frequency was 20dB below limit line within 1-18GHz, there is not show in the report.		

Mark	Frequency (MHz)	Reading Level (dB $\mu$ V)	Factor (dB)	Measure Level (dB $\mu$ V/m)	Limit (dB $\mu$ V/m)	Margin (dB)	Detector	Polarization
	4905.4	35.2	2.7	37.9	74.0	-36.1	Peak	Horizontal
*	6894.8	33.9	6.5	40.4	79.7	-39.3	Peak	Horizontal
	8248.8	35.2	8.1	43.3	74.0	-30.7	Peak	Horizontal
*	9652.5	32.7	11.0	43.7	79.7	-36.0	Peak	Horizontal
	4872.3	34.8	2.7	37.5	74.0	-36.5	Peak	Vertical
*	6582.0	34.9	6.0	40.9	79.7	-38.8	Peak	Vertical
	8247.2	34.5	8.1	42.6	74.0	-31.4	Peak	Vertical
*	9255.4	33.0	10.2	43.2	79.7	-36.5	Peak	Vertical

Note 1: "\*" is not in restricted band, its limit is 20dBc of the fundamental emission level (99.7dB $\mu$ V/m).

Note 2: Measure Level (dB $\mu$ V/m) = Reading Level (dB $\mu$ V) + Factor (dB)

Factor (dB) = Cable Loss (dB) + Antenna Factor (dB/m) - Pre\_Amplifier Gain (dB)

**The worst case of Radiated Emission 9KHz ~ 1GHz and 18GHz ~ 25GHz:**

Site: AC1	Time: 2015/04/02 - 18:51
Limit: FCC_Part15.209_RE(3m)	Engineer: Roy Cheng
Probe: VULB9162_0.03-8GHz	Polarity: Horizontal
EUT: Tablet PC	Power: AC 120V/60Hz
<b>Worse Case Mode: DH5 at Channel 2402MHz</b>	

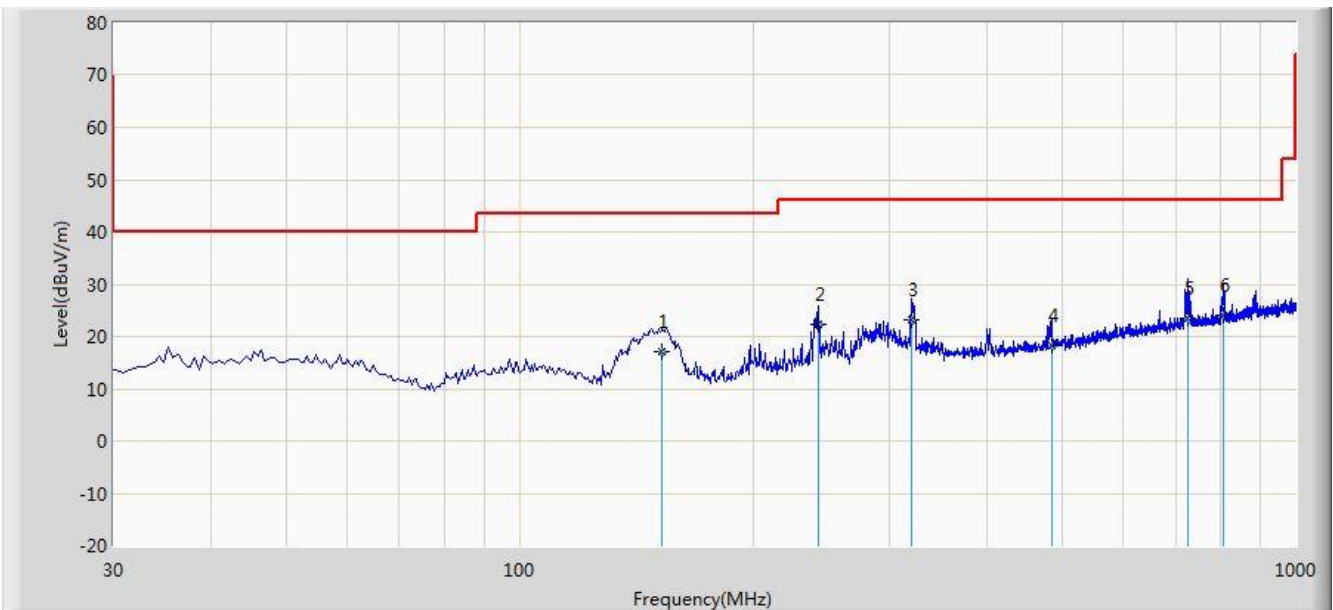

No	Flag	Mark	Frequency (MHz)	Measure Level (dBuV/m)	Reading Level (dBuV)	Over Limit (dB)	Limit (dBuV/m)	Factor (dB)	Type
1			152.702	17.171	7.630	-26.329	43.500	9.541	QP
2			242.420	22.386	8.955	-23.614	46.000	13.431	QP
3			320.515	23.290	8.255	-22.710	46.000	15.035	QP
4			484.540	18.230	0.254	-27.770	46.000	17.976	QP
5			726.460	23.416	1.588	-22.584	46.000	21.828	QP
6		*	808.425	24.109	1.255	-21.891	46.000	22.854	QP

Note: Measure Level (dBuV/m) = Reading Level (dBuV) + Factor (dB)

Factor (dB) = Cable Loss (dB) + Antenna Factor (dB/m)



Site: AC1	Time: 2015/04/02 - 18:51
Limit: FCC_Part15.209_RE(3m)	Engineer: Roy Cheng
Probe: VULB9162_0.03-8GHz	Polarity: Vertical
EUT: Tablet PC	Power: AC 120V/60Hz
<b>Worse Case Mode: DH5 at Channel 2402MHz</b>	

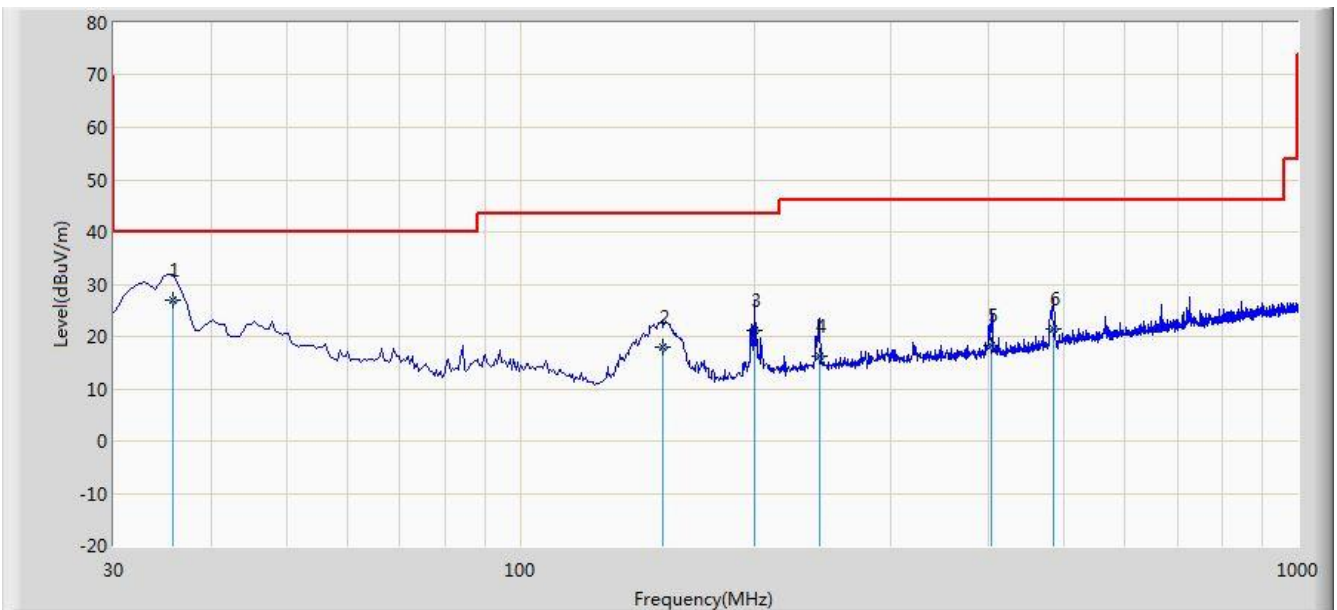

No	Flag	Mark	Frequency (MHz)	Measure Level (dBuV/m)	Reading Level (dBuV)	Over Limit (dB)	Limit (dBuV/m)	Factor (dB)	Type
1		*	35.820	27.045	13.980	-12.955	40.000	13.065	QP
2			152.220	18.065	8.542	-25.435	43.500	9.523	QP
3			199.750	21.176	8.956	-22.324	43.500	12.220	QP
4			242.430	16.099	2.668	-29.901	46.000	13.431	QP
5			404.420	18.274	1.552	-27.726	46.000	16.722	QP
6			484.450	21.329	3.355	-24.671	46.000	17.974	QP

Note: Measure Level (dBuV/m) = Reading Level (dBuV) + Factor (dB)

Factor (dB) = Cable Loss (dB) + Antenna Factor (dB/m)

Site: AC1	Time: 2015/04/01 - 15:34
Limit: FCC_Part15.209_RE(3m)	Engineer: Roy Cheng
Probe: FMZB1519_0.009-30MHz	Polarity: Face On
EUT: Tablet PC	Power: AC 120V/60Hz
<b>Note: There is the ambient noise within frequency range 9kHz~30MHz.</b>	

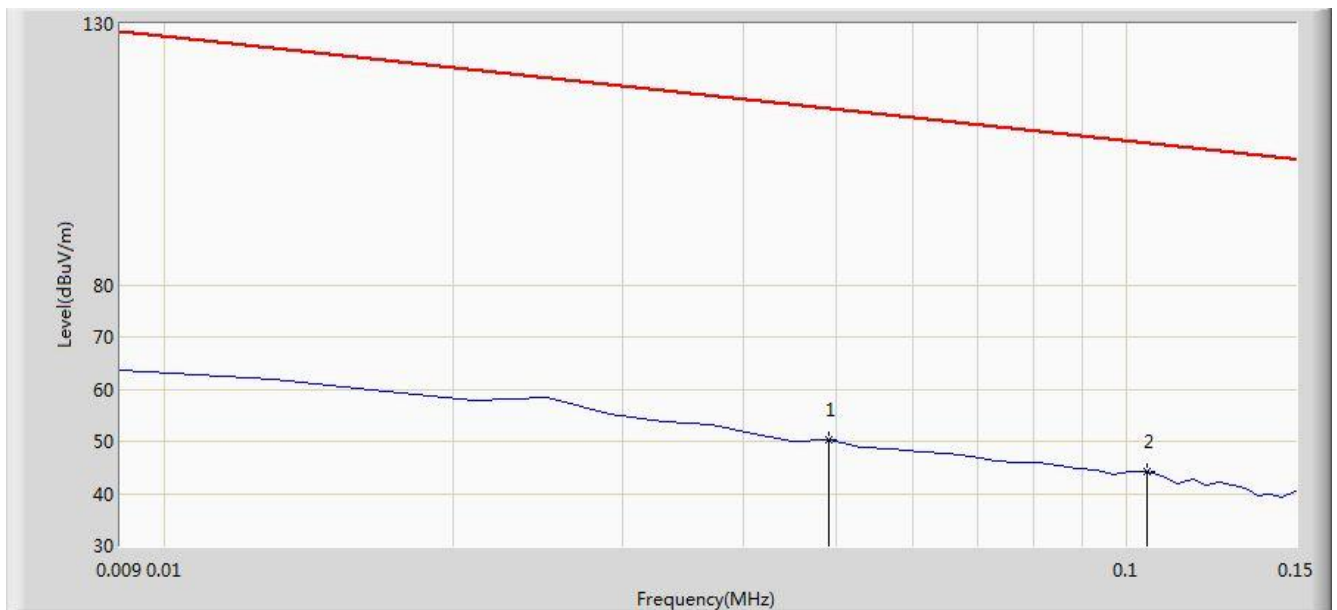

No	Flag	Mark	Frequency (MHz)	Measure Level (dBuV/m)	Reading Level (dBuV)	Over Limit (dB)	Limit (dBuV/m)	Factor (dB)	Type
1			0.049	50.367	29.861	-63.422	113.789	20.505	QP
2		*	0.105	44.143	23.996	-63.029	107.173	20.147	QP

Note: Measure Level (dBuV/m) = Reading Level (dBuV) + Factor (dB)

Factor (dB) = Cable Loss (dB) + Antenna Factor (dB/m)

Site: AC1	Time: 2015/04/01 - 15:45
Limit: FCC_Part15.209_RE(3m)	Engineer: Roy Cheng
Probe: FMZB1519_0.009-30MHz	Polarity: Face On
EUT: Tablet PC	Power: AC 120V/60Hz
<b>Note: There is the ambient noise within frequency range 9kHz~30MHz.</b>	

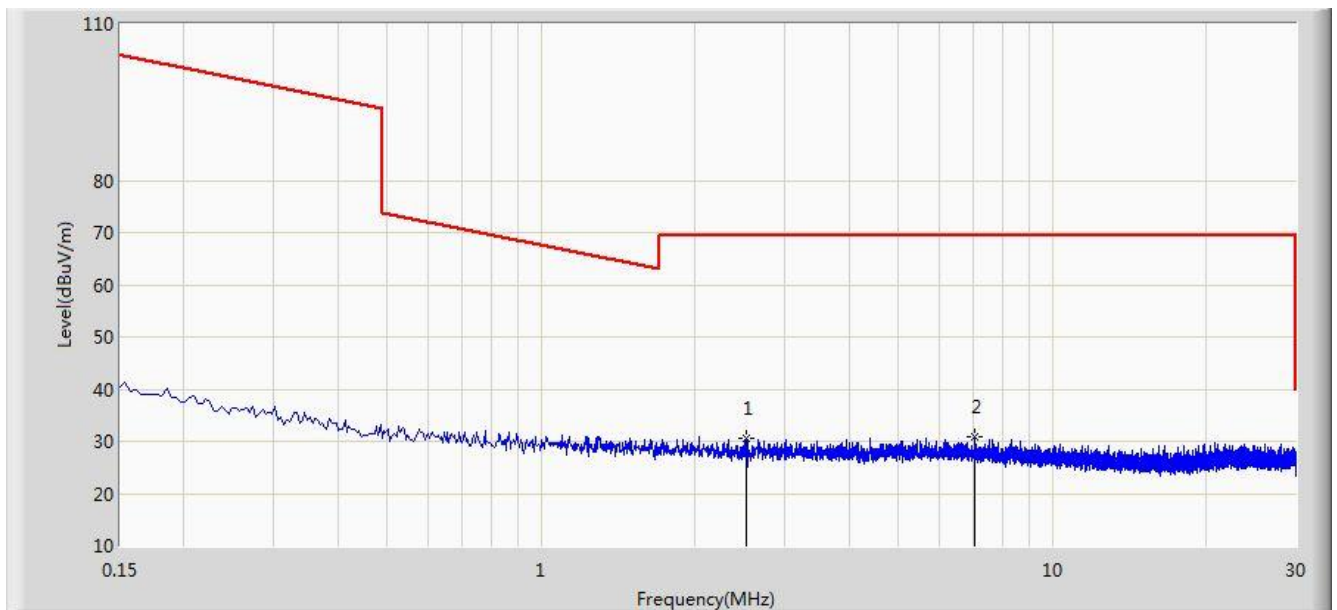

No	Flag	Mark	Frequency (MHz)	Measure Level (dBuV/m)	Reading Level (dBuV)	Over Limit (dB)	Limit (dBuV/m)	Factor (dB)	Type
1			2.513	30.495	10.336	-39.005	69.500	20.159	QP
2		*	7.041	30.974	10.579	-38.526	69.500	20.395	QP

Note: Measure Level (dB $\mu$ V/m) = Reading Level (dB $\mu$ V) + Factor (dB)

Factor (dB) = Cable Loss (dB) + Antenna Factor (dB/m)

Site: AC1	Time: 2015/03/27 - 15:45
Limit: FCC_Part15.209_RE(3m)	Engineer: Roy Cheng
Probe: BBHA9170_18-40GHz	Polarity: Horizontal
EUT: Tablet PC	Power: AC 120V/60Hz
<b>Note: There is the ambient noise within frequency range 18 ~ 25GHz.</b>	

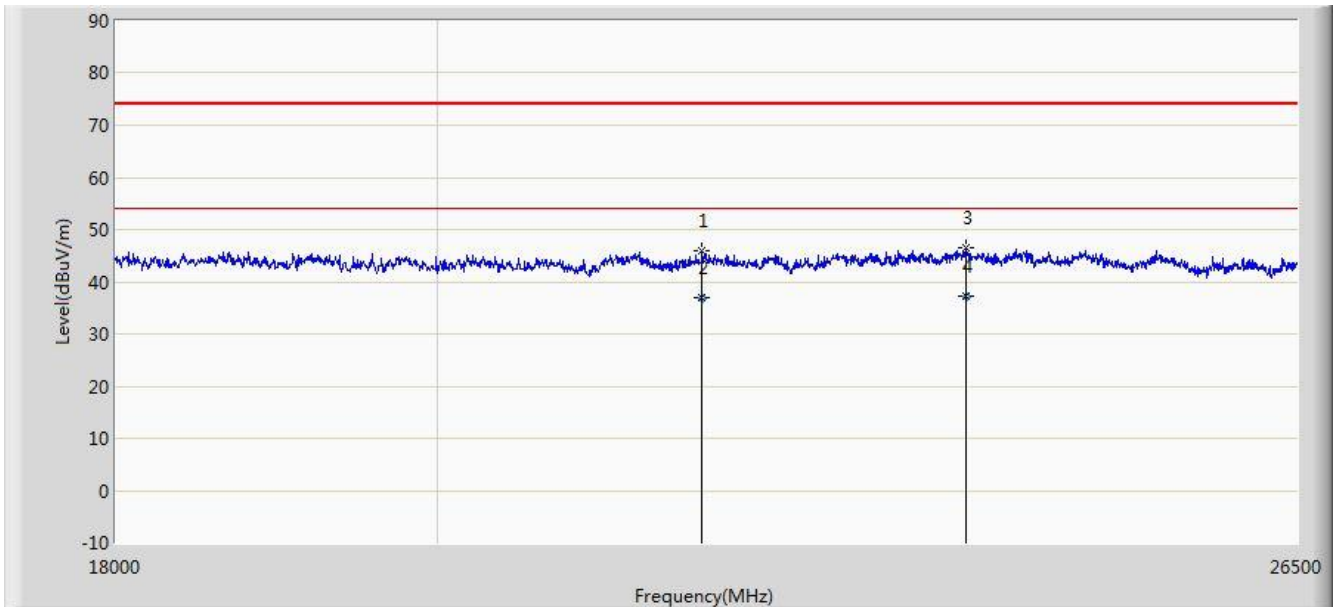

No	Flag	Mark	Frequency (MHz)	Measure Level (dBuV/m)	Reading Level (dBuV)	Over Limit (dB)	Limit (dBuV/m)	Factor (dB)	Type
1			21812.250	45.806	29.003	-28.194	74.000	16.803	PK
2			21812.325	36.857	20.054	-17.143	54.000	16.803	AV
3			23775.750	46.455	26.496	-27.545	74.000	19.958	PK
4		*	23775.850	37.113	17.154	-16.887	54.000	19.958	AV

Note: Measure Level (dB $\mu$ V/m) = Reading Level (dB $\mu$ V) + Factor (dB)

Factor (dB) = Cable Loss (dB) + Antenna Factor (dB/m) - Pre\_Amplifier Gain (dB)

Site: AC1	Time: 2015/03/27 - 15:59
Limit: FCC_Part15.209_RE(3m)	Engineer: Roy Cheng
Probe: BBHA9170_18-40GHz	Polarity: Vertical
EUT: Tablet PC	Power: AC 120V/60Hz
<b>Note: There is the ambient noise within frequency range 18 ~ 25GHz.</b>	

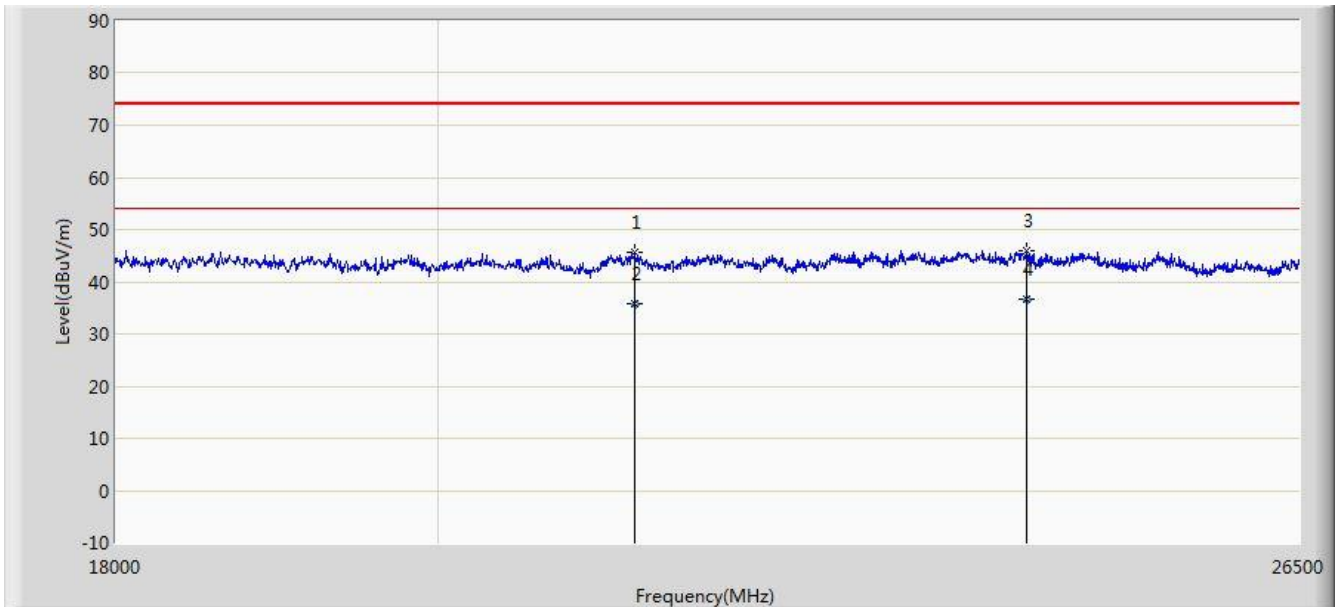

No	Flag	Mark	Frequency (MHz)	Measure Level (dBuV/m)	Reading Level (dBuV)	Over Limit (dB)	Limit (dBuV/m)	Factor (dB)	Type
1			21332.000	45.658	28.830	-28.342	74.000	16.828	PK
2		*	21332.020	35.761	18.933	-18.239	54.000	16.828	AV
3			24239.000	46.056	25.484	-27.944	74.000	20.572	PK
4			24239.040	36.783	16.210	-17.217	54.000	20.572	AV

Note: Measure Level (dB $\mu$ V/m) = Reading Level (dB $\mu$ V) + Factor (dB)

Factor (dB) = Cable Loss (dB) + Antenna Factor (dB/m) - Pre\_Amplifier Gain (dB)

## 7.10. Radiated Restricted Band Edge Measurement

### 7.10.1. Test Result

Site: AC1	Time: 2015/03/28 - 19:33
Limit: FCC_Part15.209_RE(3m)	Engineer: Roy Cheng
Probe: BBHA9120D_1-18GHz	Polarity: Horizontal
EUT: Tablet PC	Power: AC 120V/60Hz
Test Mode: Transmit at channel 2402MHz By DH5	

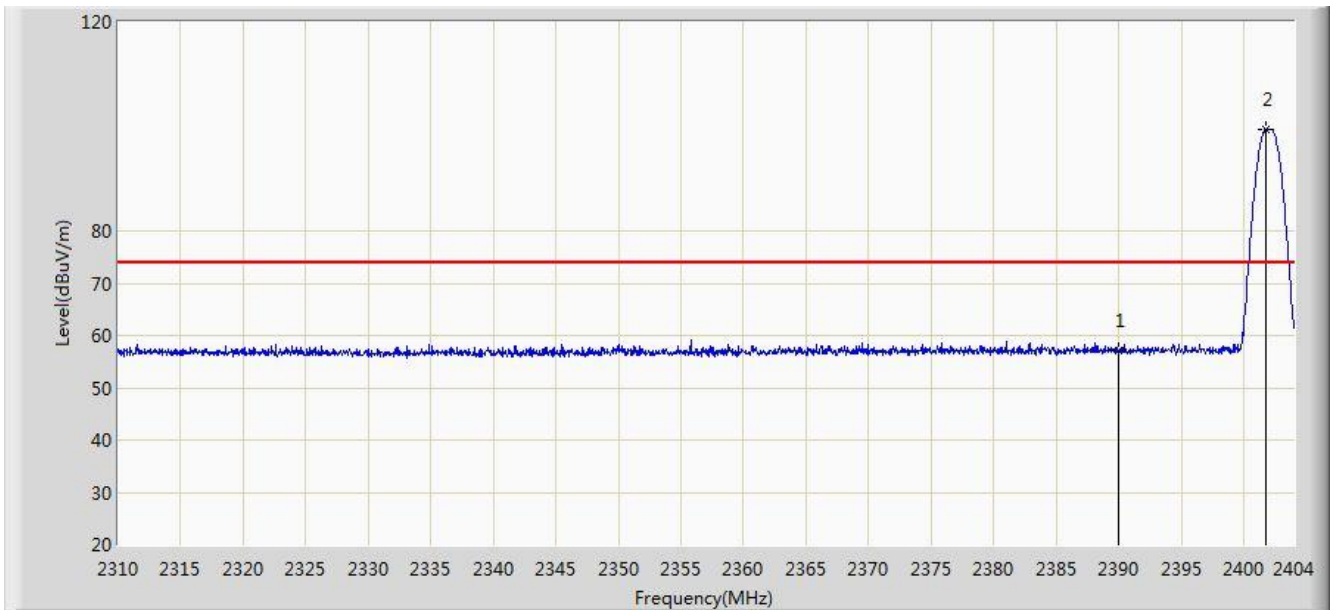

No	Flag	Mark	Frequency (MHz)	Measure Level (dBuV/m)	Reading Level (dBuV)	Over Limit (dB)	Limit (dBuV/m)	Factor (dB)	Type
1			2390.000	57.147	25.944	-16.853	74.000	31.203	PK
2		*	2401.744	99.390	68.206	N/A	N/A	31.184	PK

Note: Measure Level (dB $\mu$ V/m) = Reading Level (dB $\mu$ V) + Factor (dB)

Factor (dB) = Cable Loss (dB) + Antenna Factor (dB/m)

Site: AC1	Time: 2015/03/28 - 19:39
Limit: FCC_Part15.209_RE(3m)	Engineer: Roy Cheng
Probe: BBHA9120D_1-18GHz	Polarity: Horizontal
EUT: Tablet PC	Power: AC 120V/60Hz
Test Mode: Transmit at channel 2402MHz By DH5	

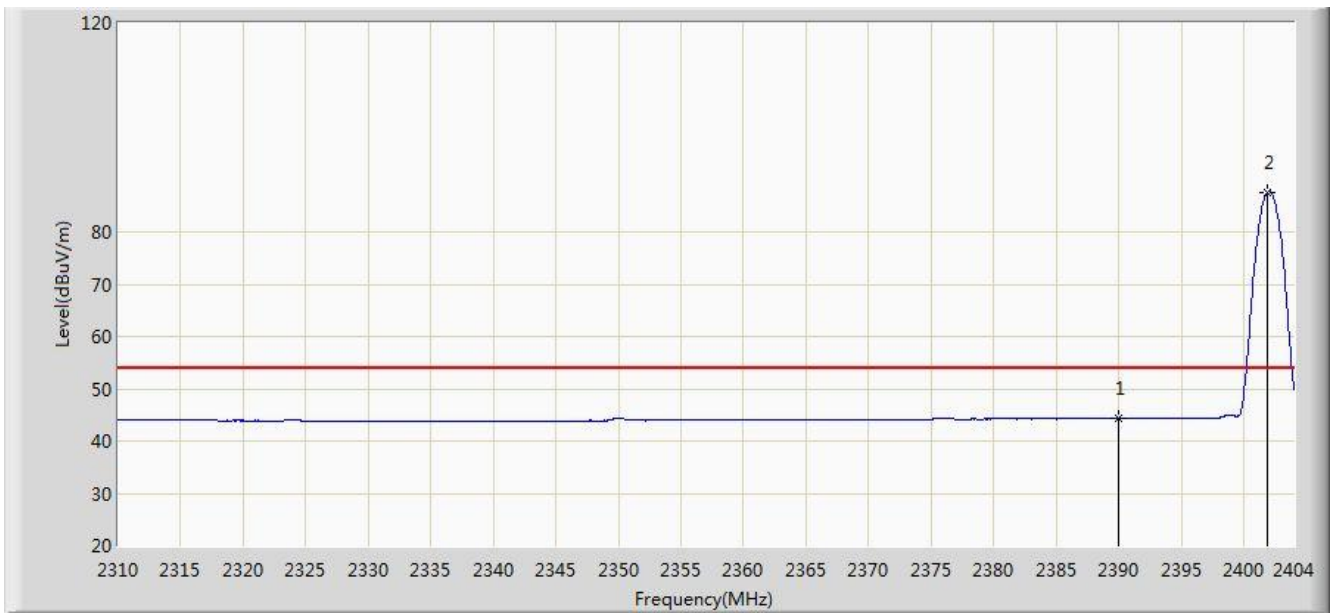

No	Flag	Mark	Frequency (MHz)	Measure Level (dBuV/m)	Reading Level (dBuV)	Over Limit (dB)	Limit (dBuV/m)	Factor (dB)	Type
1			2390.000	44.268	13.065	-9.732	54.000	31.203	AV
2		*	2401.932	87.604	56.420	N/A	N/A	31.184	AV

Note: Measure Level (dB $\mu$ V/m) = Reading Level (dB $\mu$ V) + Factor (dB)

Factor (dB) = Cable Loss (dB) + Antenna Factor (dB/m)

Site: AC1	Time: 2015/03/28 - 19:39
Limit: FCC_Part15.209_RE(3m)	Engineer: Roy Cheng
Probe: BBHA9120D_1-18GHz	Polarity: Vertical
EUT: Tablet PC	Power: AC 120V/60Hz
Test Mode: Transmit at channel 2402MHz By DH5	

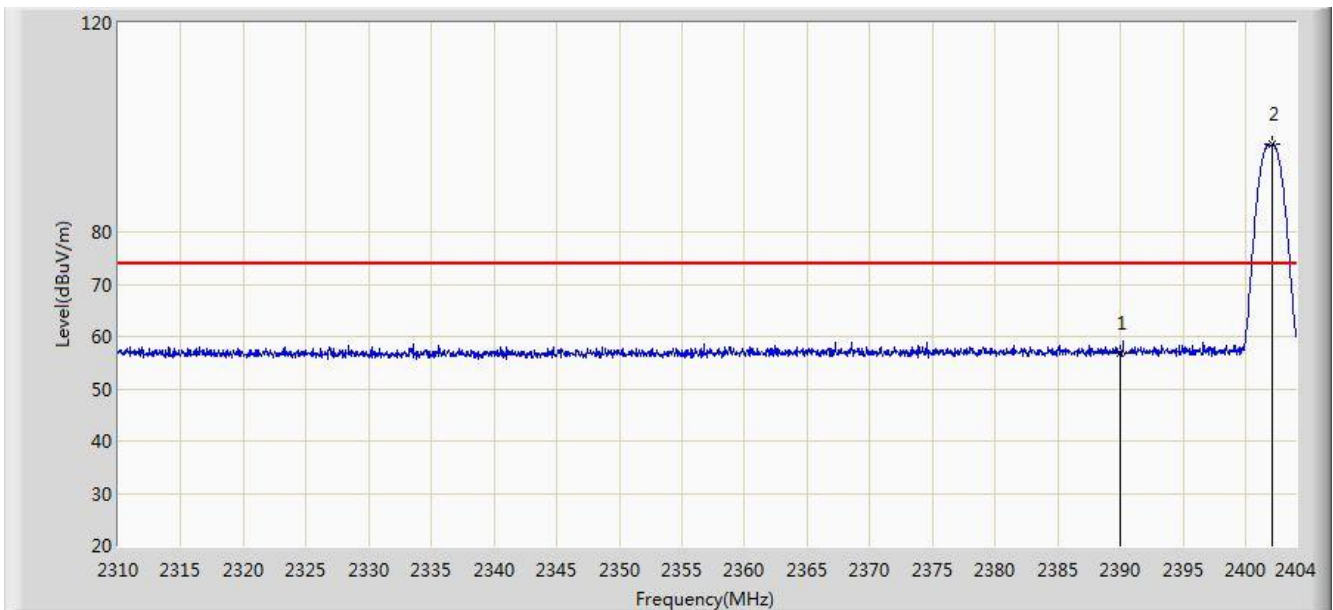

No	Flag	Mark	Frequency (MHz)	Measure Level (dBuV/m)	Reading Level (dBuV)	Over Limit (dB)	Limit (dBuV/m)	Factor (dB)	Type
1			2390.000	56.945	25.742	-17.055	74.000	31.203	PK
2		*	2402.073	96.673	65.489	N/A	N/A	31.184	PK

Note: Measure Level (dB $\mu$ V/m) = Reading Level (dB $\mu$ V) + Factor (dB)

Factor (dB) = Cable Loss (dB) + Antenna Factor (dB/m)



Site: AC1	Time: 2015/03/28 - 19:41
Limit: FCC_Part15.209_RE(3m)	Engineer: Roy Cheng
Probe: BBHA9120D_1-18GHz	Polarity: Vertical
EUT: Tablet PC	Power: AC 120V/60Hz
Test Mode: Transmit at channel 2402MHz By DH5	

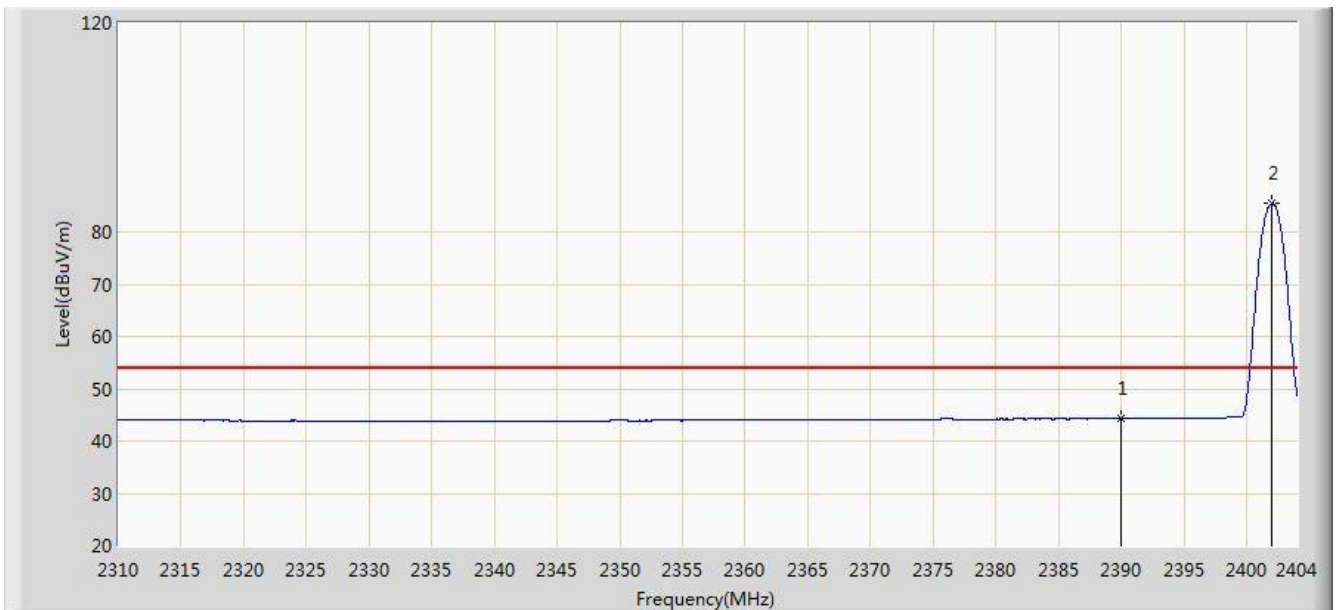

No	Flag	Mark	Frequency (MHz)	Measure Level (dBuV/m)	Reading Level (dBuV)	Over Limit (dB)	Limit (dBuV/m)	Factor (dB)	Type
1			2390.000	44.287	13.084	-9.713	54.000	31.203	AV
2		*	2401.979	85.446	54.262	N/A	N/A	31.184	AV

Note: Measure Level (dBuV/m) = Reading Level (dBuV) + Factor (dB)

Factor (dB) = Cable Loss (dB) + Antenna Factor (dB/m)

Site: AC1	Time: 2015/03/28 - 19:42
Limit: FCC_Part15.209_RE(3m)	Engineer: Roy Cheng
Probe: BBHA9120D_1-18GHz	Polarity: Horizontal
EUT: Tablet PC	Power: AC 120V/60Hz
Test Mode: Transmit at channel 2480MHz By DH5	

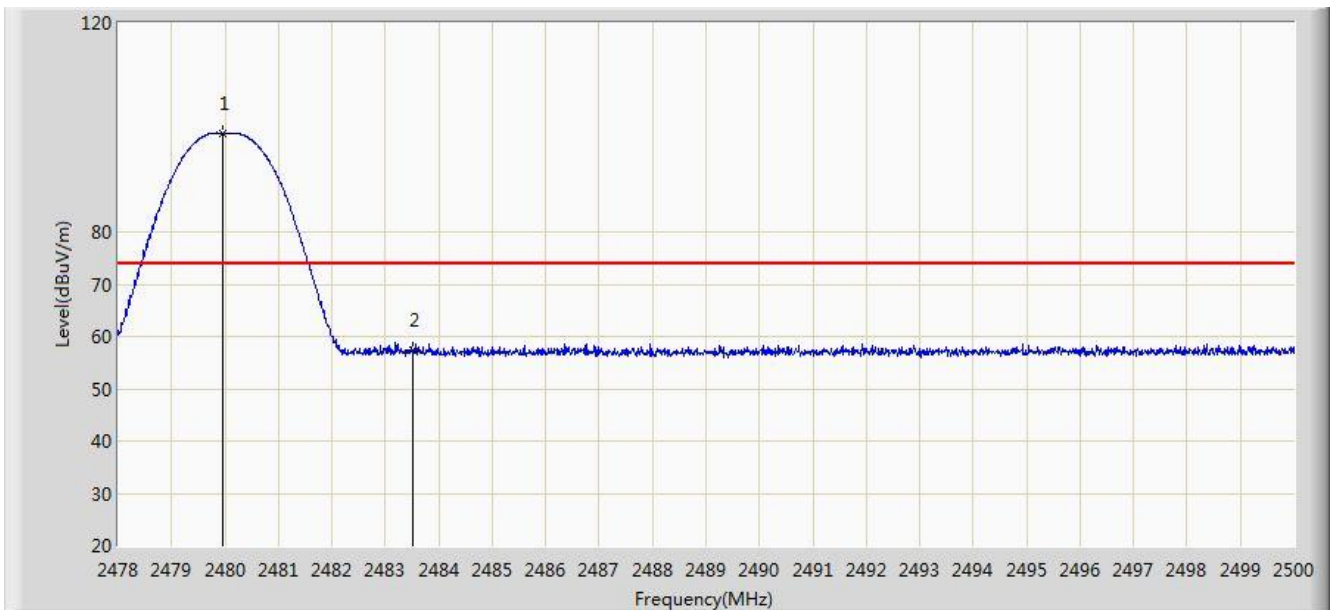

No	Flag	Mark	Frequency (MHz)	Measure Level (dBuV/m)	Reading Level (dBuV)	Over Limit (dB)	Limit (dBuV/m)	Factor (dB)	Type
1		*	2479.969	98.853	67.669	N/A	N/A	31.184	PK
2			2483.500	57.438	26.245	-16.562	74.000	31.194	PK

Note: Measure Level (dB $\mu$ V/m) = Reading Level (dB $\mu$ V) + Factor (dB)

Factor (dB) = Cable Loss (dB) + Antenna Factor (dB/m)

Site: AC1	Time: 2015/03/28 - 20:12
Limit: FCC_Part15.209_RE(3m)	Engineer: Roy Cheng
Probe: BBHA9120D_1-18GHz	Polarity: Horizontal
EUT: Tablet PC	Power: AC 120V/60Hz
Test Mode: Transmit at channel 2480MHz By DH5	

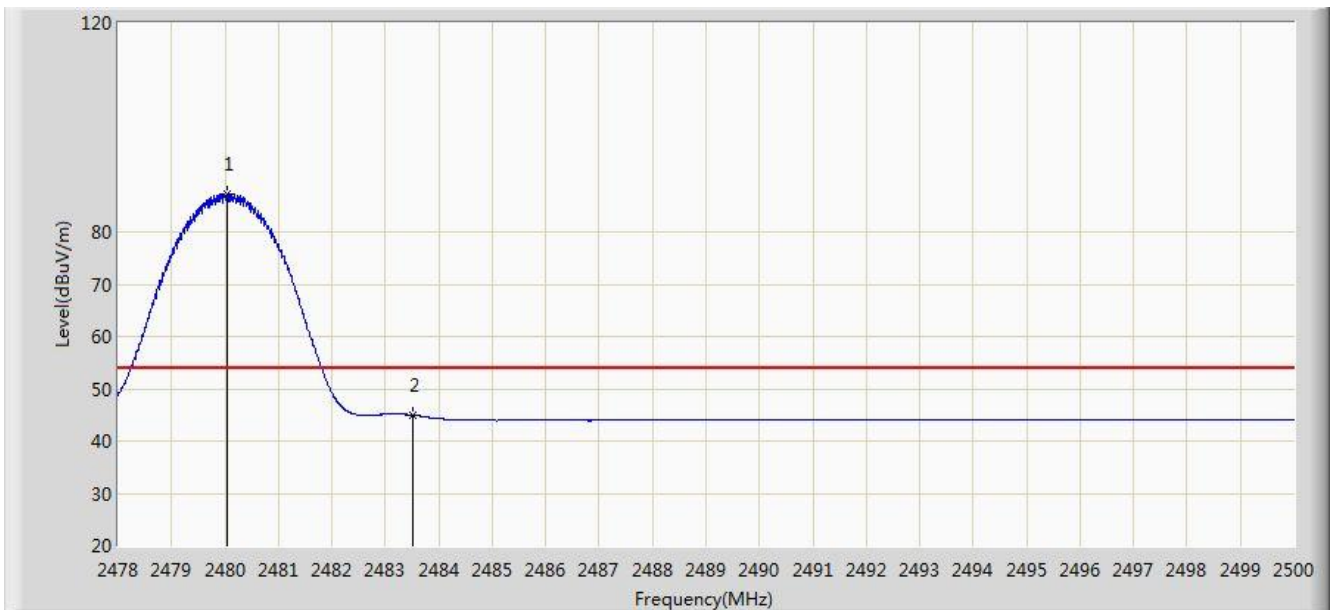

No	Flag	Mark	Frequency (MHz)	Measure Level (dBuV/m)	Reading Level (dBuV)	Over Limit (dB)	Limit (dBuV/m)	Factor (dB)	Type
1		*	2480.035	87.386	56.202	N/A	N/A	31.184	AV
2			2483.500	44.976	13.783	-9.024	54.000	31.194	AV

Note: Measure Level (dBuV/m) = Reading Level (dBuV) + Factor (dB)

Factor (dB) = Cable Loss (dB) + Antenna Factor (dB/m)

Site: AC1	Time: 2015/03/28 - 20:13
Limit: FCC_Part15.209_RE(3m)	Engineer: Roy Cheng
Probe: BBHA9120D_1-18GHz	Polarity: Vertical
EUT: Tablet PC	Power: AC 120V/60Hz
Test Mode: Transmit at channel 2480MHz By DH5	

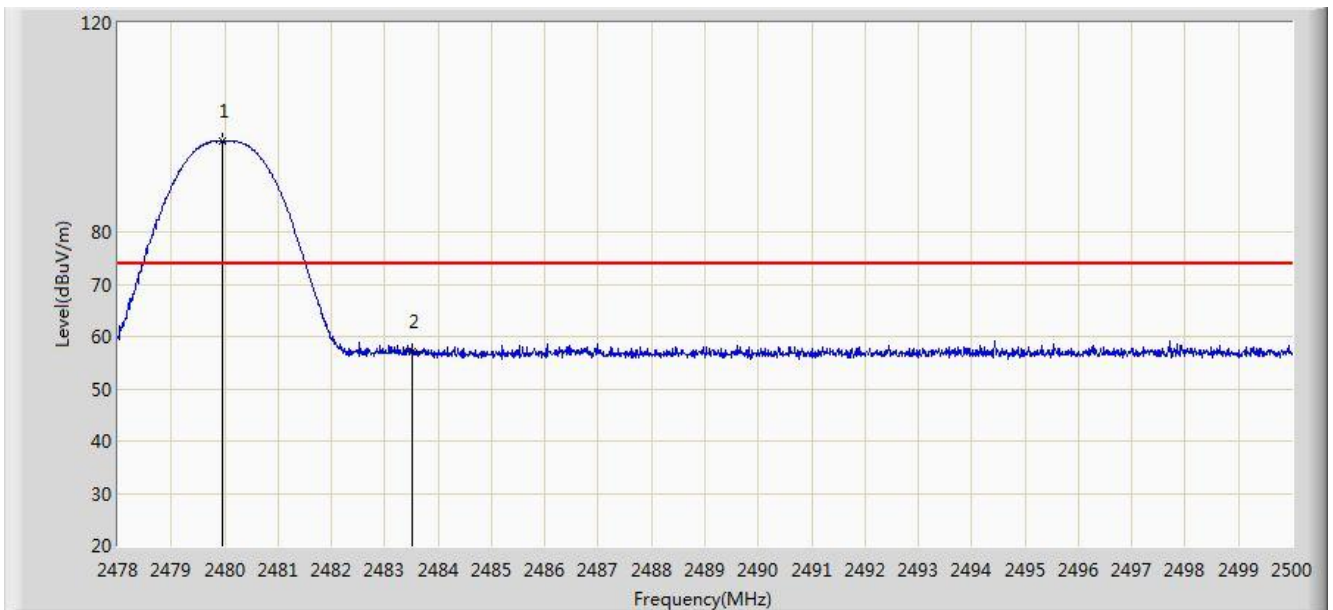

No	Flag	Mark	Frequency (MHz)	Measure Level (dBuV/m)	Reading Level (dBuV)	Over Limit (dB)	Limit (dBuV/m)	Factor (dB)	Type
1		*	2479.969	97.311	66.127	N/A	N/A	31.184	PK
2			2483.500	56.959	25.766	-17.041	74.000	31.194	PK

Note: Measure Level (dB $\mu$ V/m) = Reading Level (dB $\mu$ V) + Factor (dB)

Factor (dB) = Cable Loss (dB) + Antenna Factor (dB/m)

Site: AC1	Time: 2015/03/28 - 20:15
Limit: FCC_Part15.209_RE(3m)	Engineer: Roy Cheng
Probe: BBHA9120D_1-18GHz	Polarity: Vertical
EUT: Tablet PC	Power: AC 120V/60Hz
Test Mode: Transmit at channel 2480MHz By DH5	

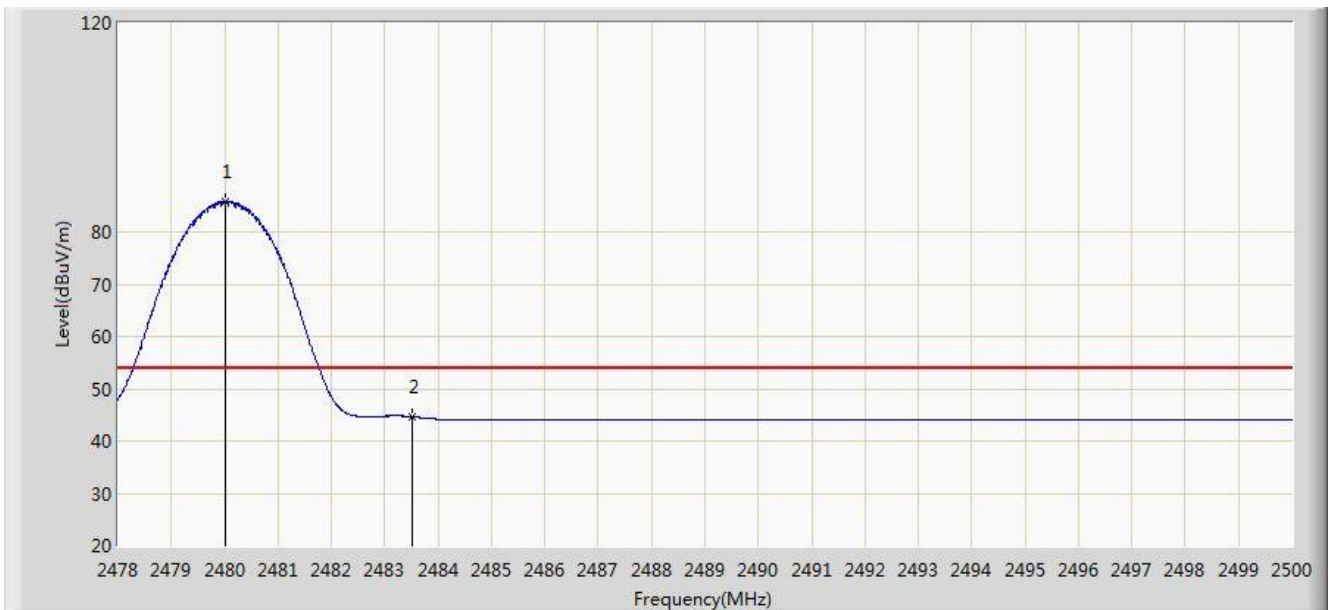

No	Flag	Mark	Frequency (MHz)	Measure Level (dBuV/m)	Reading Level (dBuV)	Over Limit (dB)	Limit (dBuV/m)	Factor (dB)	Type
1		*	2480.002	85.774	54.590	N/A	N/A	31.184	AV
2			2483.500	44.669	13.476	-9.331	54.000	31.194	AV

Note: Measure Level (dBuV/m) = Reading Level (dBuV) + Factor (dB)

Factor (dB) = Cable Loss (dB) + Antenna Factor (dB/m)

Site: AC1	Time: 2015/03/28 - 20:15
Limit: FCC_Part15.209_RE(3m)	Engineer: Roy Cheng
Probe: BBHA9120D_1-18GHz	Polarity: Horizontal
EUT: Tablet PC	Power: AC 120V/60Hz
Test Mode: Transmit at channel 2402MHz By 2DH5	

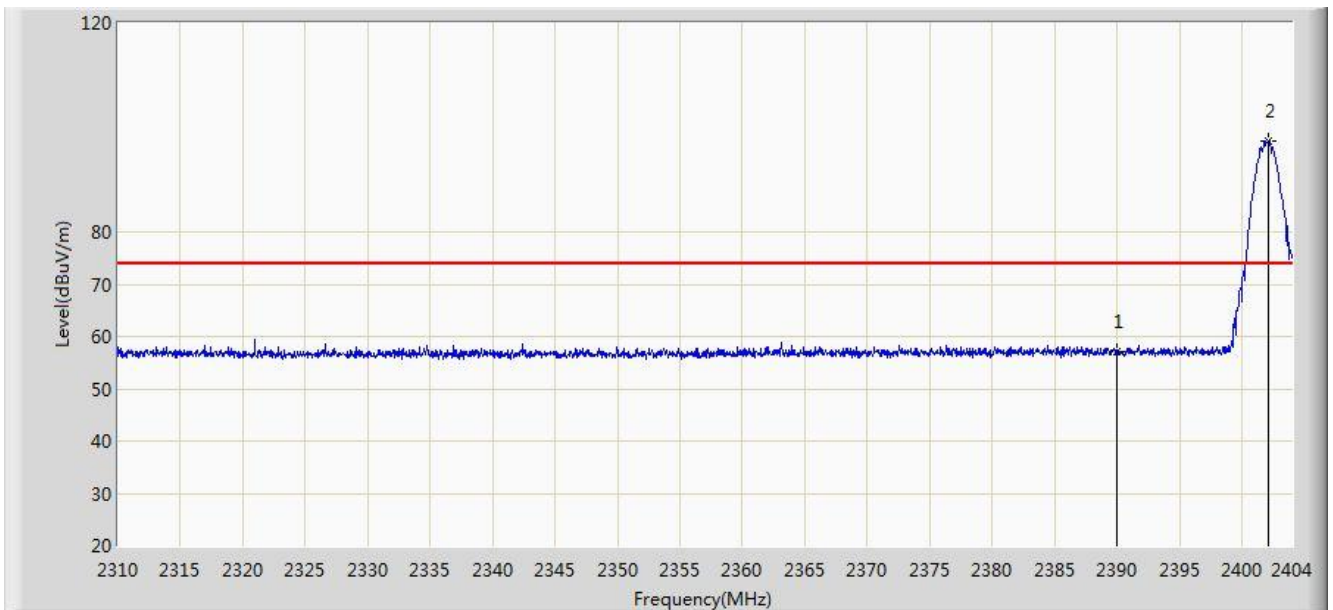

No	Flag	Mark	Frequency (MHz)	Measure Level (dBuV/m)	Reading Level (dBuV)	Over Limit (dB)	Limit (dBuV/m)	Factor (dB)	Type
1			2390.000	57.170	25.967	-16.830	74.000	31.203	PK
2		*	2402.167	97.492	66.308	N/A	N/A	31.184	PK

Note: Measure Level (dBuV/m) = Reading Level (dBuV) + Factor (dB)

Factor (dB) = Cable Loss (dB) + Antenna Factor (dB/m)

Site: AC1	Time: 2015/03/28 - 20:18
Limit: FCC_Part15.209_RE(3m)	Engineer: Roy Cheng
Probe: BBHA9120D_1-18GHz	Polarity: Horizontal
EUT: Tablet PC	Power: AC 120V/60Hz
Test Mode: Transmit at channel 2402MHz By 2DH5	

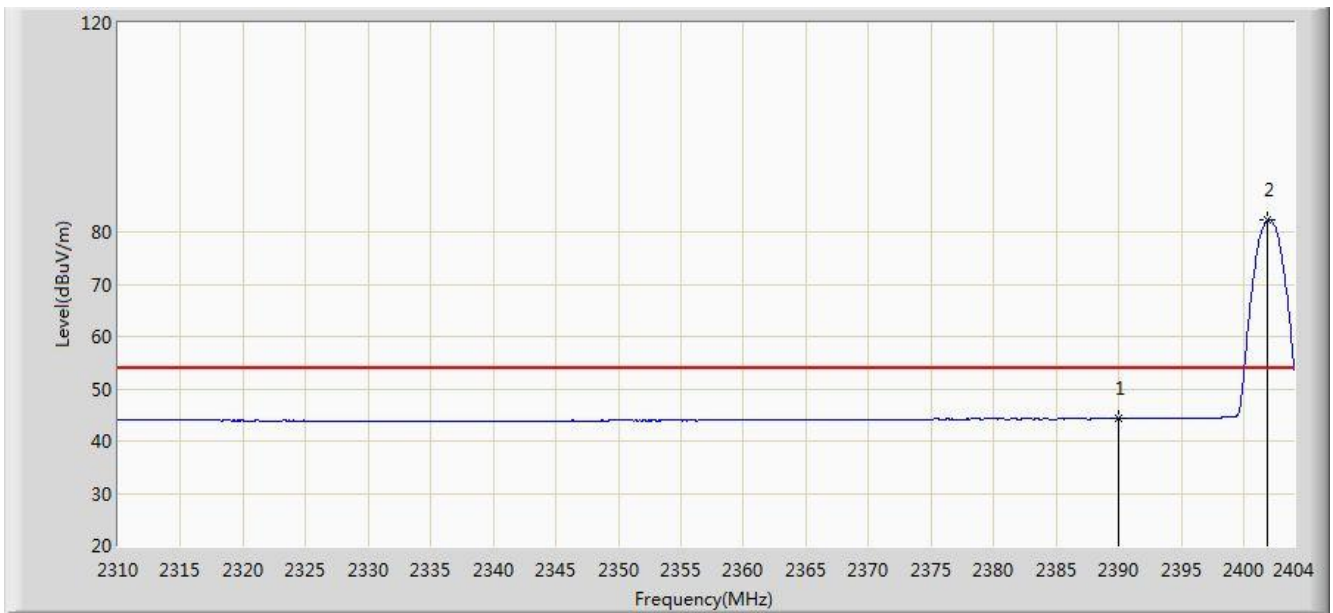

No	Flag	Mark	Frequency (MHz)	Measure Level (dBuV/m)	Reading Level (dBuV)	Over Limit (dB)	Limit (dBuV/m)	Factor (dB)	Type
1			2390.000	44.282	13.079	-9.718	54.000	31.203	AV
2		*	2401.932	82.330	51.146	N/A	N/A	31.184	AV

Note: Measure Level (dBuV/m) = Reading Level (dBuV) + Factor (dB)

Factor (dB) = Cable Loss (dB) + Antenna Factor (dB/m)

Site: AC1	Time: 2015/03/28 - 20:18
Limit: FCC_Part15.209_RE(3m)	Engineer: Roy Cheng
Probe: BBHA9120D_1-18GHz	Polarity: Vertical
EUT: Tablet PC	Power: AC 120V/60Hz
Test Mode: Transmit at channel 2402MHz By 2DH5	

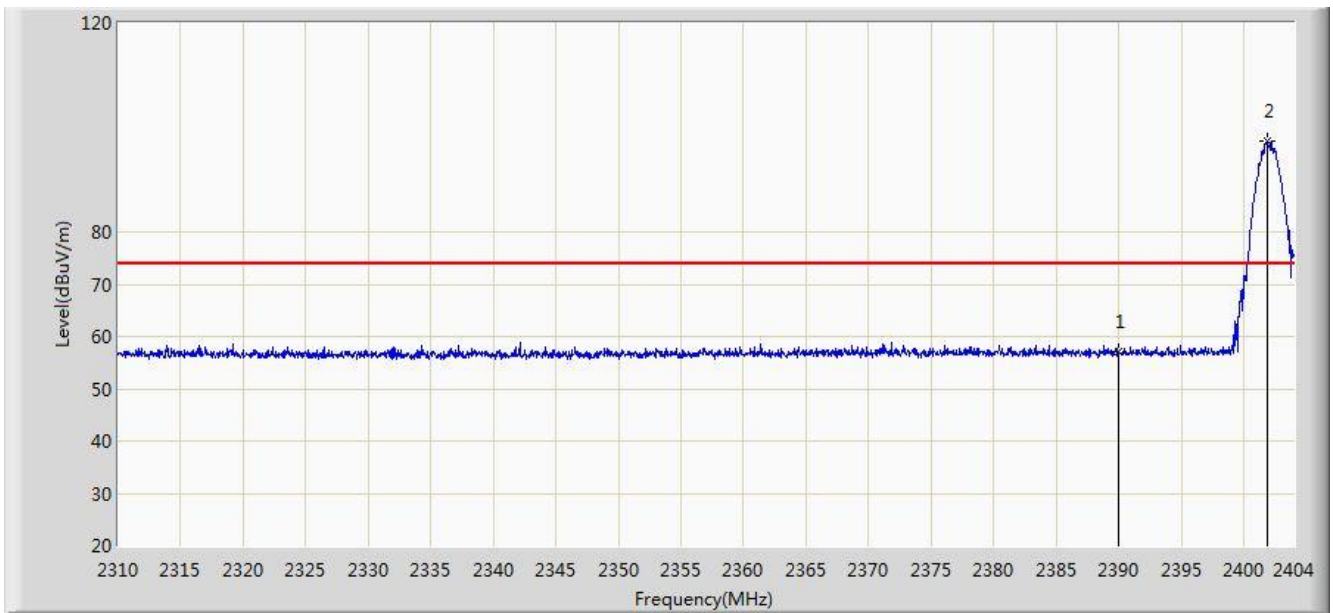

No	Flag	Mark	Frequency (MHz)	Measure Level (dBuV/m)	Reading Level (dBuV)	Over Limit (dB)	Limit (dBuV/m)	Factor (dB)	Type
1			2390.000	57.104	25.901	-16.896	74.000	31.203	PK
2		*	2401.885	97.417	66.233	N/A	N/A	31.184	PK

Note: Measure Level (dBuV/m) = Reading Level (dBuV) + Factor (dB)

Factor (dB) = Cable Loss (dB) + Antenna Factor (dB/m)



Site: AC1	Time: 2015/03/28 - 20:20
Limit: FCC_Part15.209_RE(3m)	Engineer: Roy Cheng
Probe: BBHA9120D_1-18GHz	Polarity: Vertical
EUT: Tablet PC	Power: AC 120V/60Hz
Test Mode: Transmit at channel 2402MHz By 2DH5	

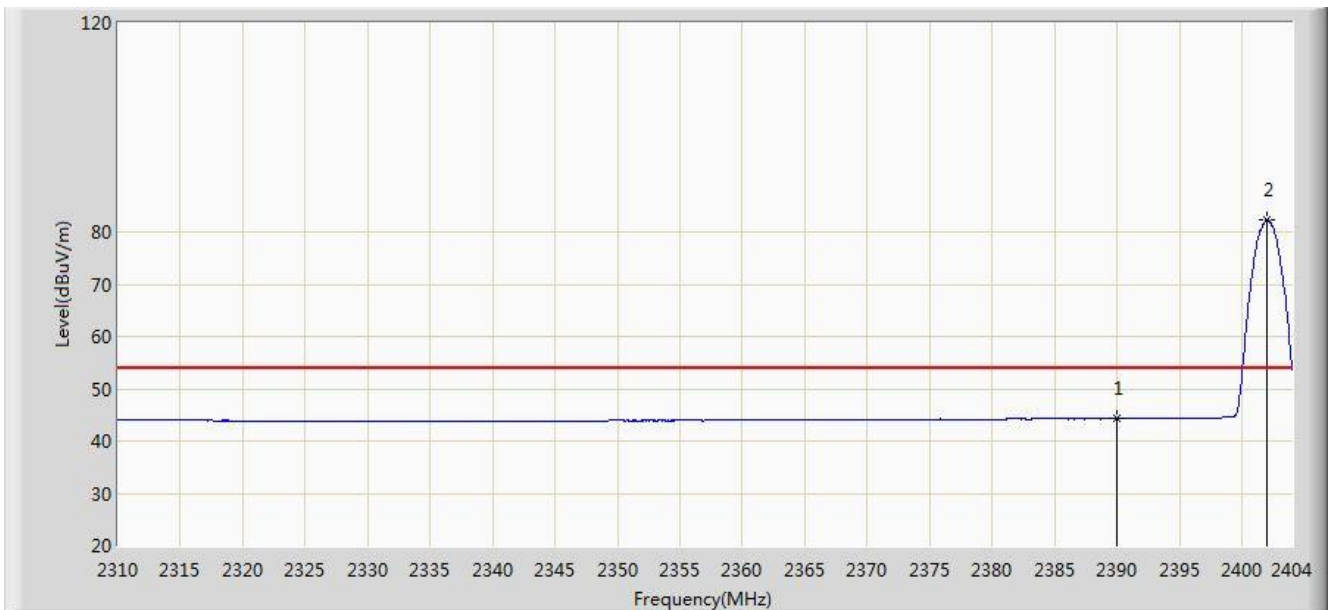

No	Flag	Mark	Frequency (MHz)	Measure Level (dBuV/m)	Reading Level (dBuV)	Over Limit (dB)	Limit (dBuV/m)	Factor (dB)	Type
1			2390.000	44.248	13.045	-9.752	54.000	31.203	AV
2		*	2402.026	82.275	51.091	N/A	N/A	31.184	AV

Note: Measure Level (dB $\mu$ V/m) = Reading Level (dB $\mu$ V) + Factor (dB)

Factor (dB) = Cable Loss (dB) + Antenna Factor (dB/m)

Site: AC1	Time: 2015/03/28 - 20:20
Limit: FCC_Part15.209_RE(3m)	Engineer: Roy Cheng
Probe: BBHA9120D_1-18GHz	Polarity: Horizontal
EUT: Tablet PC	Power: AC 120V/60Hz
Test Mode: Transmit at channel 2480MHz By 2DH5	

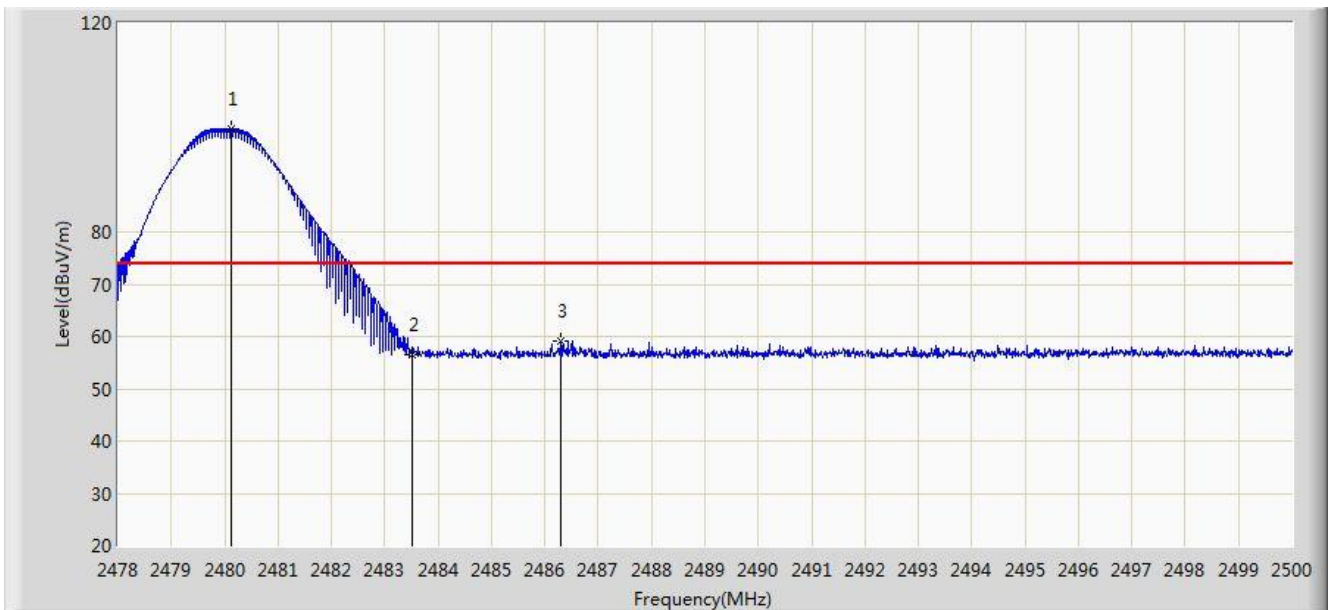

No	Flag	Mark	Frequency (MHz)	Measure Level (dBuV/m)	Reading Level (dBuV)	Over Limit (dB)	Limit (dBuV/m)	Factor (dB)	Type
1		*	2480.112	99.734	68.550	N/A	N/A	31.184	PK
2			2483.500	56.512	25.319	-17.488	74.000	31.194	PK
3			2486.294	59.043	27.842	-14.957	74.000	31.201	PK

Note: Measure Level (dB $\mu$ V/m) = Reading Level (dB $\mu$ V) + Factor (dB)

Factor (dB) = Cable Loss (dB) + Antenna Factor (dB/m)

Site: AC1	Time: 2015/03/28 - 20:22
Limit: FCC_Part15.209_RE(3m)	Engineer: Roy Cheng
Probe: BBHA9120D_1-18GHz	Polarity: Horizontal
EUT: Tablet PC	Power: AC 120V/60Hz
Test Mode: Transmit at channel 2480MHz By 2DH5	

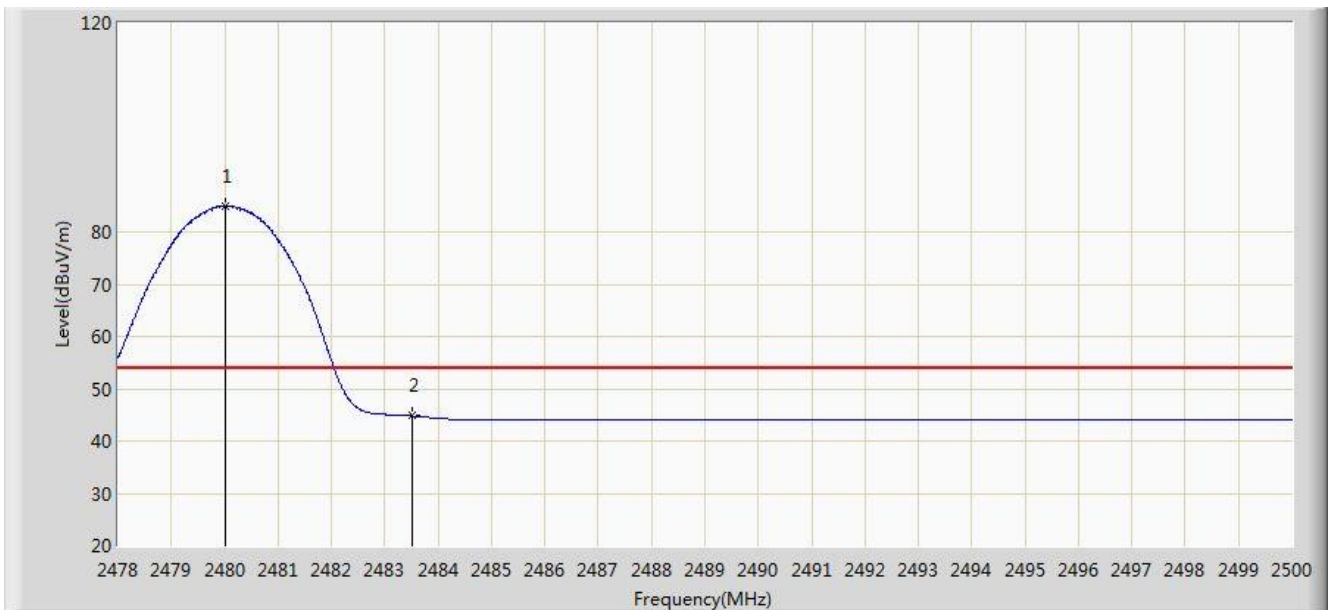

No	Flag	Mark	Frequency (MHz)	Measure Level (dBuV/m)	Reading Level (dBuV)	Over Limit (dB)	Limit (dBuV/m)	Factor (dB)	Type
1		*	2480.013	85.063	53.879	N/A	N/A	31.184	AV
2			2483.500	44.783	13.590	-9.217	54.000	31.194	AV

Note: Measure Level (dBuV/m) = Reading Level (dBuV) + Factor (dB)

Factor (dB) = Cable Loss (dB) + Antenna Factor (dB/m)

Site: AC1	Time: 2015/03/28 - 20:23
Limit: FCC_Part15.209_RE(3m)	Engineer: Roy Cheng
Probe: BBHA9120D_1-18GHz	Polarity: Vertical
EUT: Tablet PC	Power: AC 120V/60Hz
Test Mode: Transmit at channel 2480MHz By 2DH5	

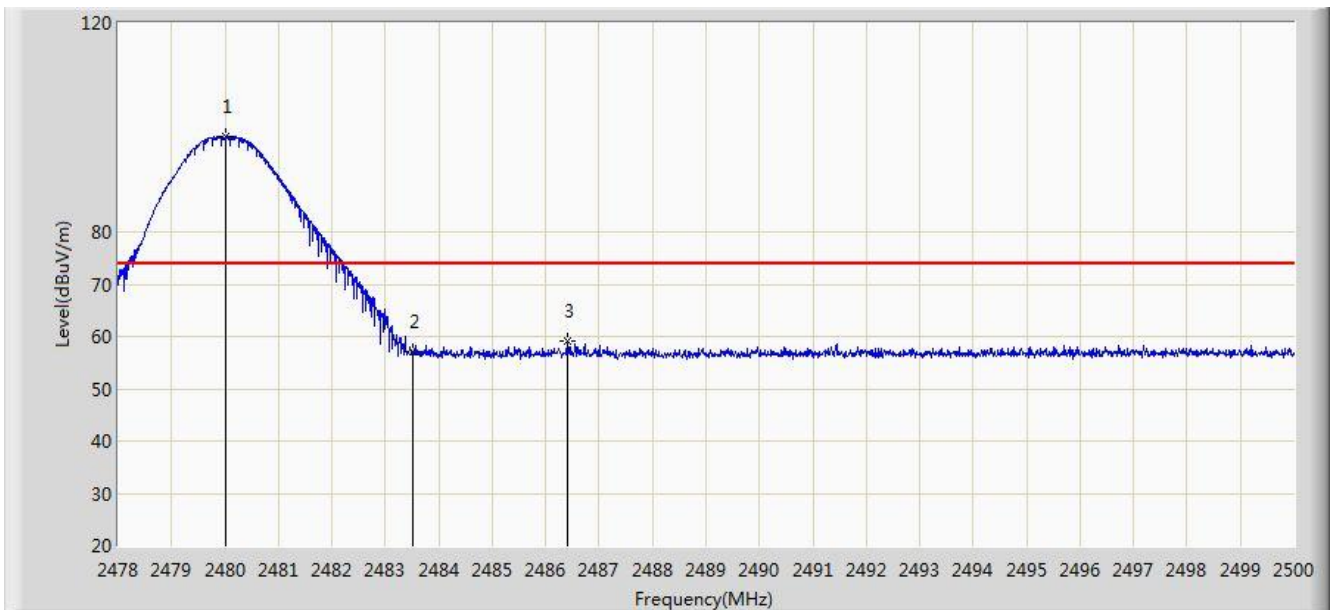

No	Flag	Mark	Frequency (MHz)	Measure Level (dBuV/m)	Reading Level (dBuV)	Over Limit (dB)	Limit (dBuV/m)	Factor (dB)	Type
1		*	2480.002	98.157	66.973	N/A	N/A	31.184	PK
2			2483.500	57.229	26.036	-16.771	74.000	31.194	PK
3			2486.404	59.079	27.878	-14.921	74.000	31.201	PK

Note: Measure Level (dB $\mu$ V/m) = Reading Level (dB $\mu$ V) + Factor (dB)

Factor (dB) = Cable Loss (dB) + Antenna Factor (dB/m)

Site: AC1	Time: 2015/03/28 - 20:24
Limit: FCC_Part15.209_RE(3m)	Engineer: Roy Cheng
Probe: BBHA9120D_1-18GHz	Polarity: Vertical
EUT: Tablet PC	Power: AC 120V/60Hz
Test Mode: Transmit at channel 2480MHz By 2DH5	

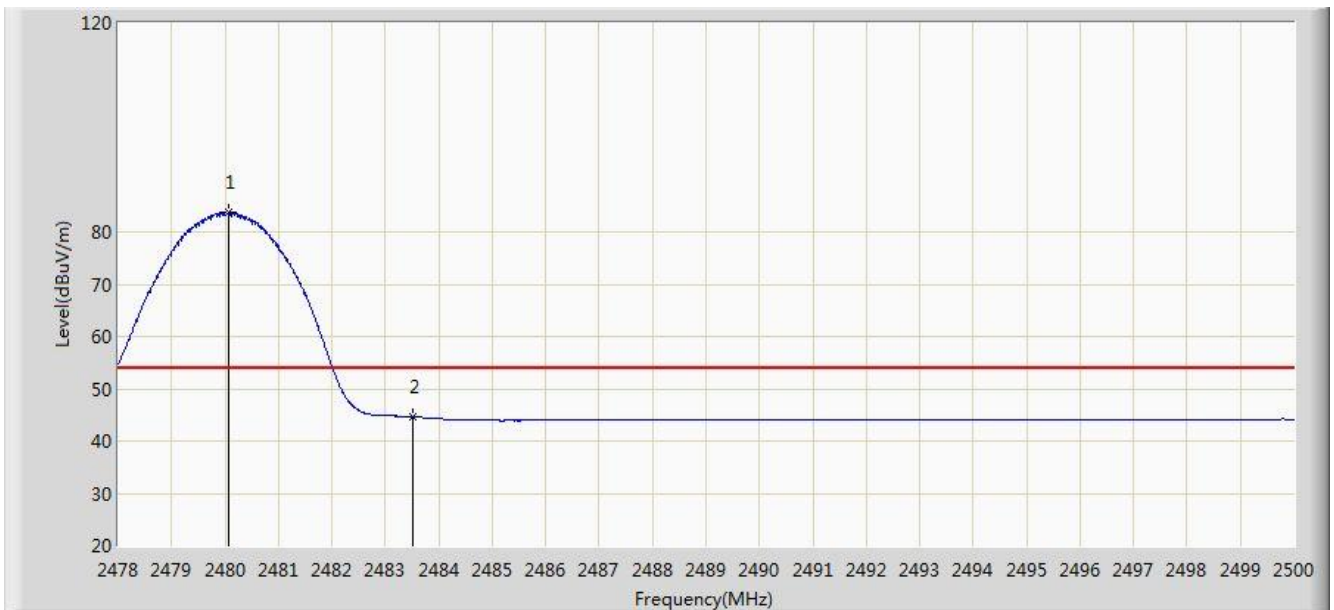

No	Flag	Mark	Frequency (MHz)	Measure Level (dBuV/m)	Reading Level (dBuV)	Over Limit (dB)	Limit (dBuV/m)	Factor (dB)	Type
1		*	2480.079	83.696	52.512	N/A	N/A	31.184	AV
2			2483.500	44.616	13.423	-9.384	54.000	31.194	AV

Note: Measure Level (dB $\mu$ V/m) = Reading Level (dB $\mu$ V) + Factor (dB)

Factor (dB) = Cable Loss (dB) + Antenna Factor (dB/m)

Site: AC1	Time: 2015/03/28 - 20:24
Limit: FCC_Part15.209_RE(3m)	Engineer: Roy Cheng
Probe: BBHA9120D_1-18GHz	Polarity: Horizontal
EUT: Tablet PC	Power: AC 120V/60Hz
Test Mode: Transmit at channel 2402MHz By 3DH5	

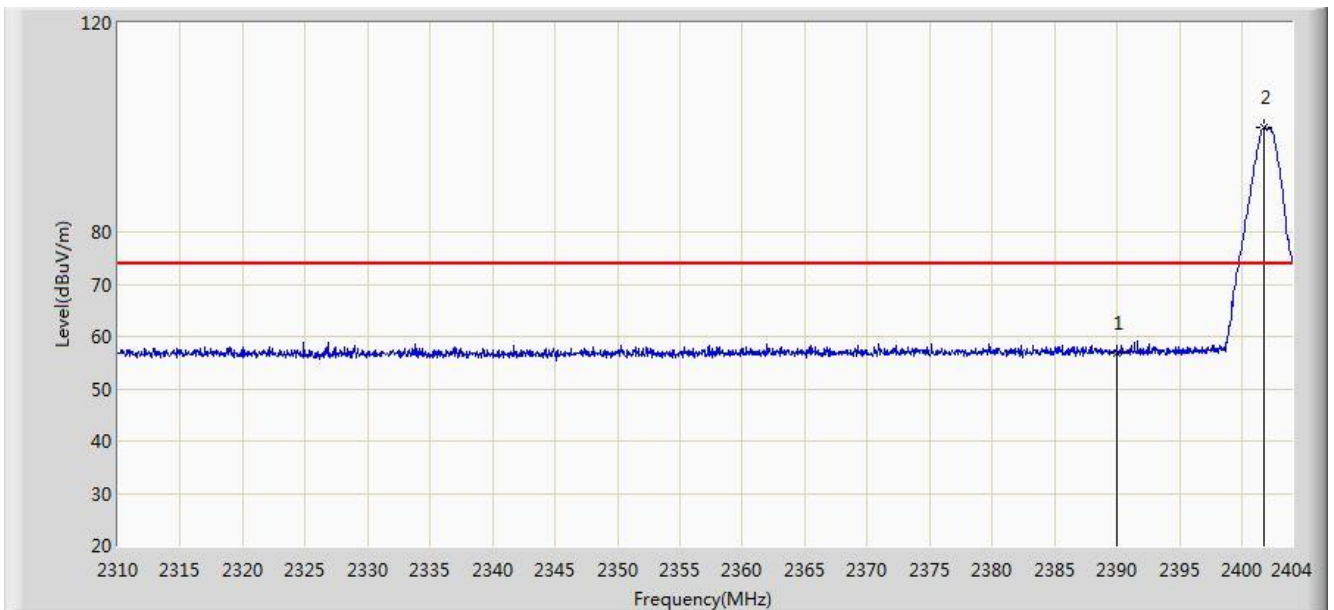

No	Flag	Mark	Frequency (MHz)	Measure Level (dBuV/m)	Reading Level (dBuV)	Over Limit (dB)	Limit (dBuV/m)	Factor (dB)	Type
1			2390.000	56.741	25.538	-17.259	74.000	31.203	PK
2		*	2401.744	100.133	68.949	N/A	N/A	31.184	PK

Note: Measure Level (dBuV/m) = Reading Level (dBuV) + Factor (dB)

Factor (dB) = Cable Loss (dB) + Antenna Factor (dB/m)

Site: AC1	Time: 2015/03/28 - 20:27
Limit: FCC_Part15.209_RE(3m)	Engineer: Roy Cheng
Probe: BBHA9120D_1-18GHz	Polarity: Horizontal
EUT: Tablet PC	Power: AC 120V/60Hz
Test Mode: Transmit at channel 2402MHz By 3DH5	

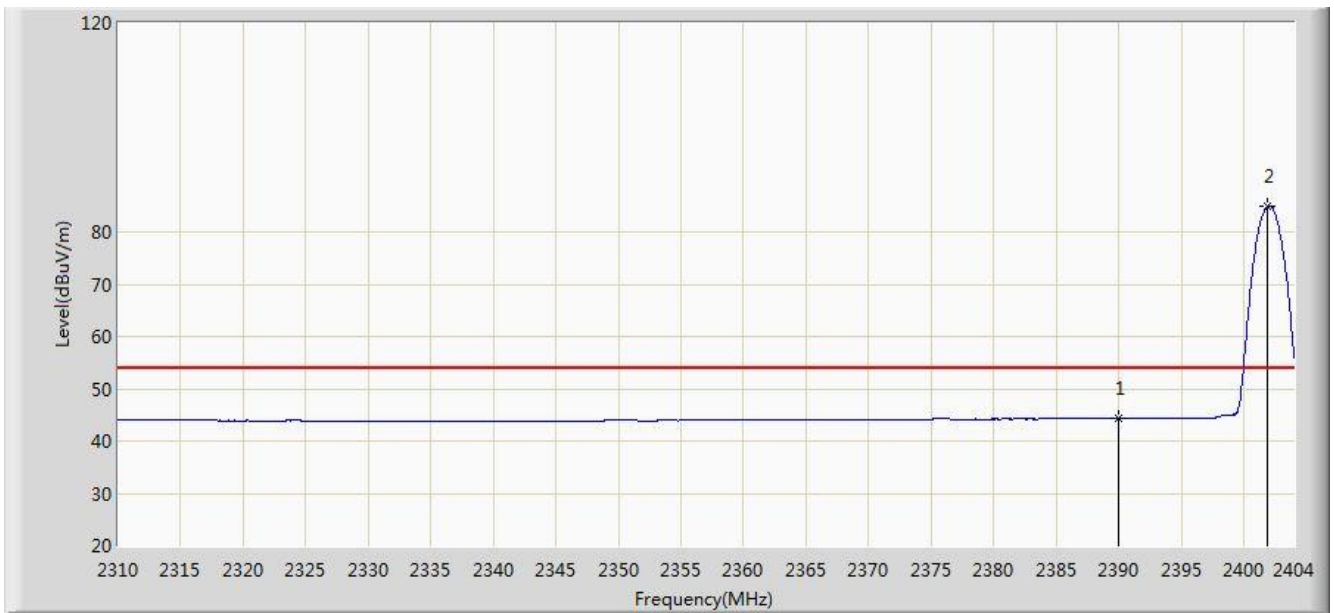

No	Flag	Mark	Frequency (MHz)	Measure Level (dBuV/m)	Reading Level (dBuV)	Over Limit (dB)	Limit (dBuV/m)	Factor (dB)	Type
1			2390.000	44.274	13.071	-9.726	54.000	31.203	AV
2		*	2401.885	84.824	53.640	N/A	N/A	31.184	AV

Note: Measure Level (dB $\mu$ V/m) = Reading Level (dB $\mu$ V) + Factor (dB)

Factor (dB) = Cable Loss (dB) + Antenna Factor (dB/m)

Site: AC1	Time: 2015/03/28 - 20:27
Limit: FCC_Part15.209_RE(3m)	Engineer: Roy Cheng
Probe: BBHA9120D_1-18GHz	Polarity: Vertical
EUT: Tablet PC	Power: AC 120V/60Hz
Test Mode: Transmit at channel 2402MHz By 3DH5	

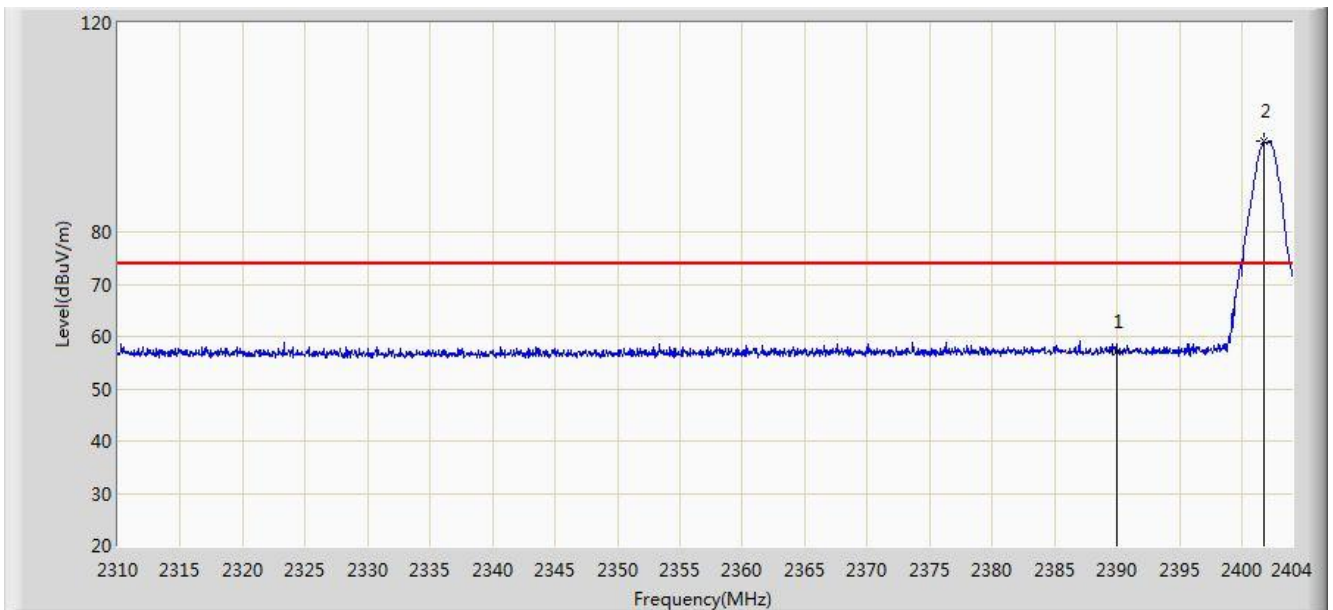

No	Flag	Mark	Frequency (MHz)	Measure Level (dBuV/m)	Reading Level (dBuV)	Over Limit (dB)	Limit (dBuV/m)	Factor (dB)	Type
1			2390.000	56.960	25.757	-17.040	74.000	31.203	PK
2		*	2401.744	97.328	66.144	N/A	N/A	31.184	PK

Note: Measure Level (dBuV/m) = Reading Level (dBuV) + Factor (dB)

Factor (dB) = Cable Loss (dB) + Antenna Factor (dB/m)



Site: AC1	Time: 2015/03/28 - 20:29
Limit: FCC_Part15.209_RE(3m)	Engineer: Roy Cheng
Probe: BBHA9120D_1-18GHz	Polarity: Vertical
EUT: Tablet PC	Power: AC 120V/60Hz
Test Mode: Transmit at channel 2402MHz By 3DH5	

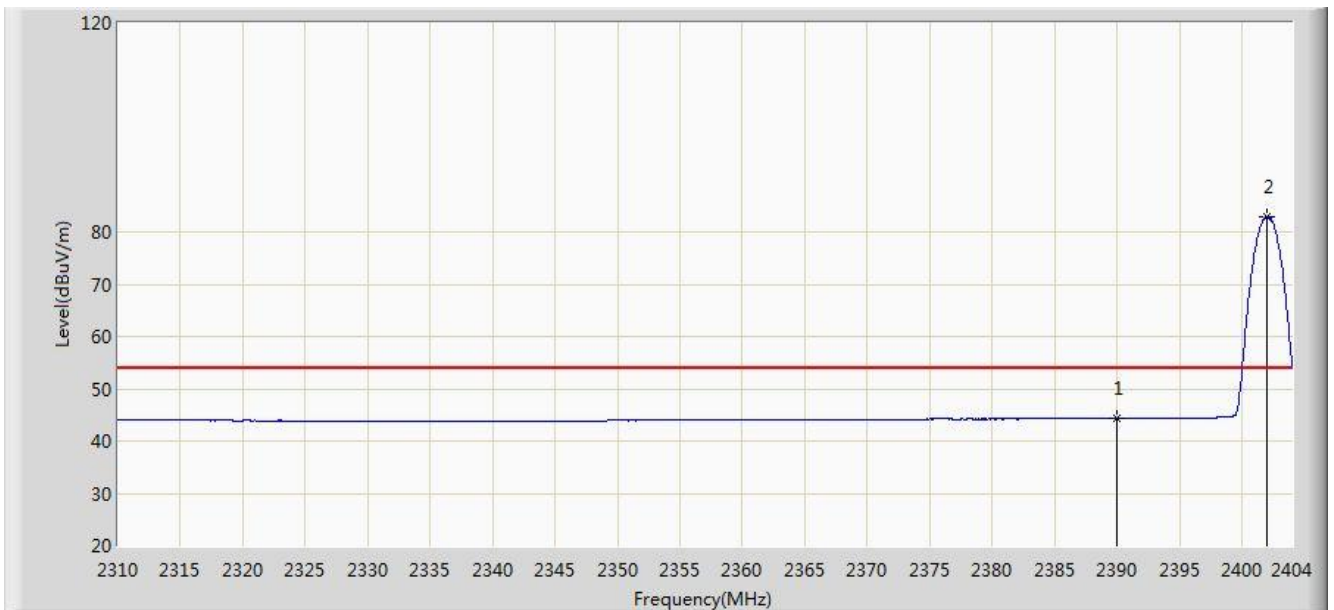

No	Flag	Mark	Frequency (MHz)	Measure Level (dBuV/m)	Reading Level (dBuV)	Over Limit (dB)	Limit (dBuV/m)	Factor (dB)	Type
1			2390.000	44.291	13.088	-9.709	54.000	31.203	AV
2		*	2401.979	82.926	51.742	N/A	N/A	31.184	AV

Note: Measure Level (dBuV/m) = Reading Level (dBuV) + Factor (dB)

Factor (dB) = Cable Loss (dB) + Antenna Factor (dB/m)

Site: AC1	Time: 2015/03/28 - 20:30
Limit: FCC_Part15.209_RE(3m)	Engineer: Roy Cheng
Probe: BBHA9120D_1-18GHz	Polarity: Horizontal
EUT: Tablet PC	Power: AC 120V/60Hz
Test Mode: Transmit at channel 2480MHz By 3DH5	

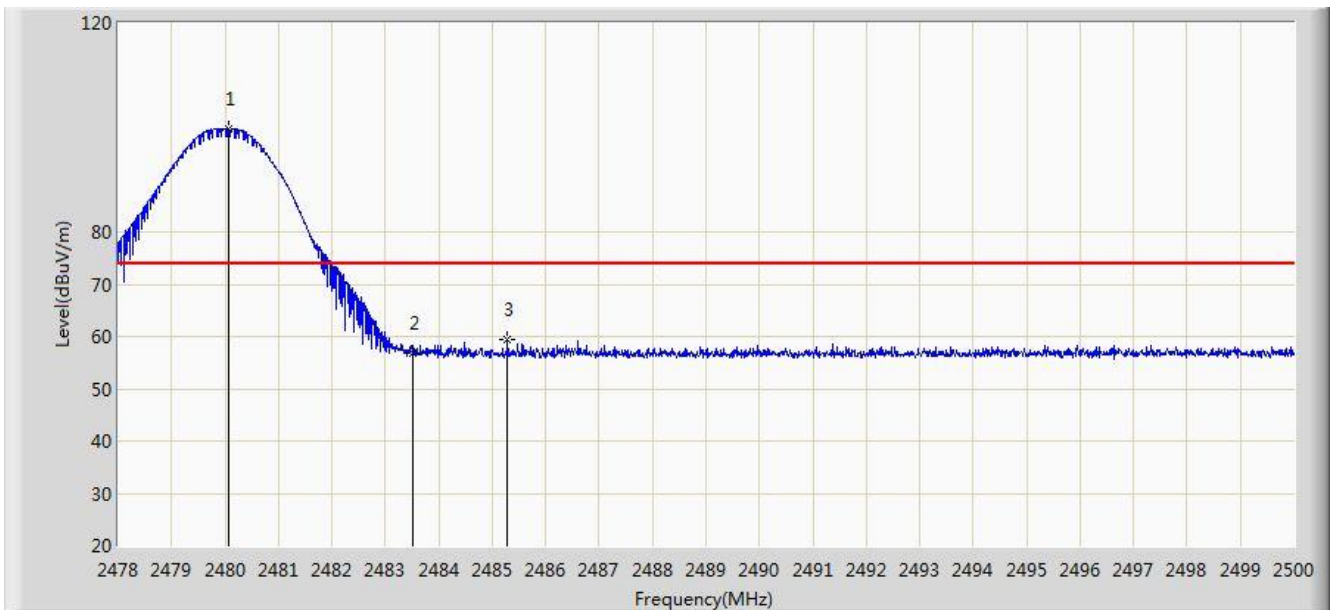

No	Flag	Mark	Frequency (MHz)	Measure Level (dBuV/m)	Reading Level (dBuV)	Over Limit (dB)	Limit (dBuV/m)	Factor (dB)	Type
1		*	2480.057	99.686	68.502	N/A	N/A	31.184	PK
2			2483.500	56.874	25.681	-17.126	74.000	31.194	PK
3			2485.282	59.295	28.097	-14.705	74.000	31.198	PK

Note: Measure Level (dB $\mu$ V/m) = Reading Level (dB $\mu$ V) + Factor (dB)

Factor (dB) = Cable Loss (dB) + Antenna Factor (dB/m)

Site: AC1	Time: 2015/03/28 - 20:32
Limit: FCC_Part15.209_RE(3m)	Engineer: Roy Cheng
Probe: BBHA9120D_1-18GHz	Polarity: Horizontal
EUT: Tablet PC	Power: AC 120V/60Hz
Test Mode: Transmit at channel 2480MHz By 3DH5	

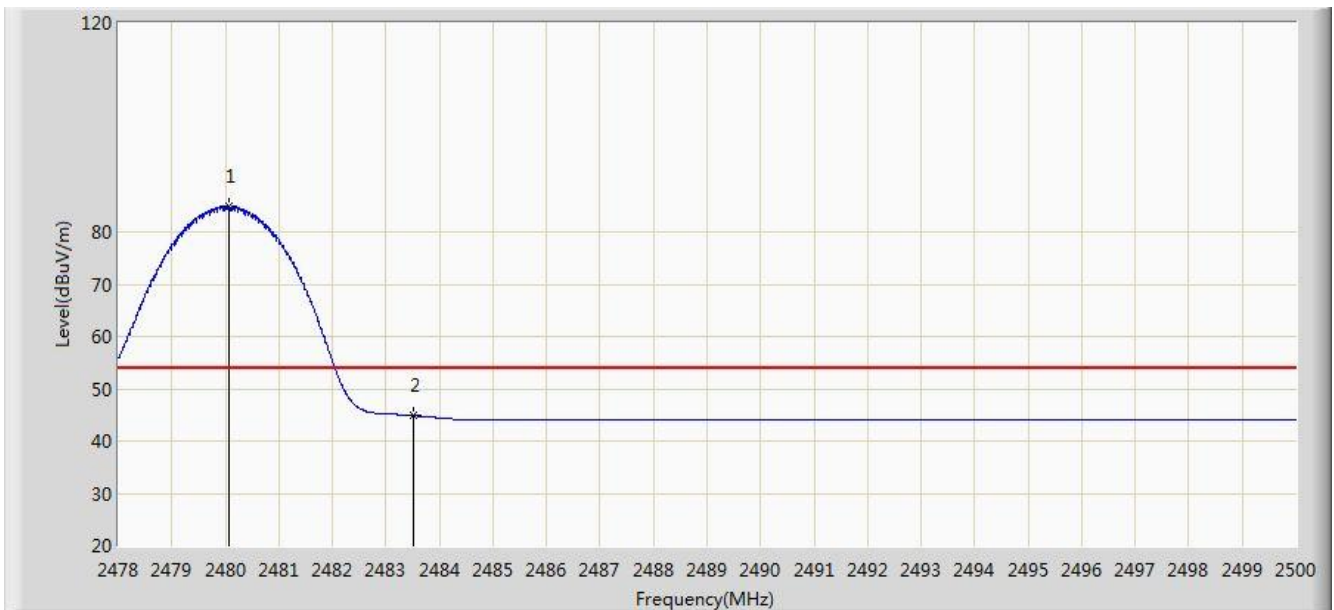

No	Flag	Mark	Frequency (MHz)	Measure Level (dBuV/m)	Reading Level (dBuV)	Over Limit (dB)	Limit (dBuV/m)	Factor (dB)	Type
1		*	2480.057	84.884	53.700	N/A	N/A	31.184	AV
2			2483.500	44.880	13.687	-9.120	54.000	31.194	AV

Note: Measure Level (dBuV/m) = Reading Level (dBuV) + Factor (dB)

Factor (dB) = Cable Loss (dB) + Antenna Factor (dB/m)

Site: AC1	Time: 2015/03/28 - 20:33
Limit: FCC_Part15.209_RE(3m)	Engineer: Roy Cheng
Probe: BBHA9120D_1-18GHz	Polarity: Vertical
EUT: Tablet PC	Power: AC 120V/60Hz
Test Mode: Transmit at channel 2480MHz By 3DH5	

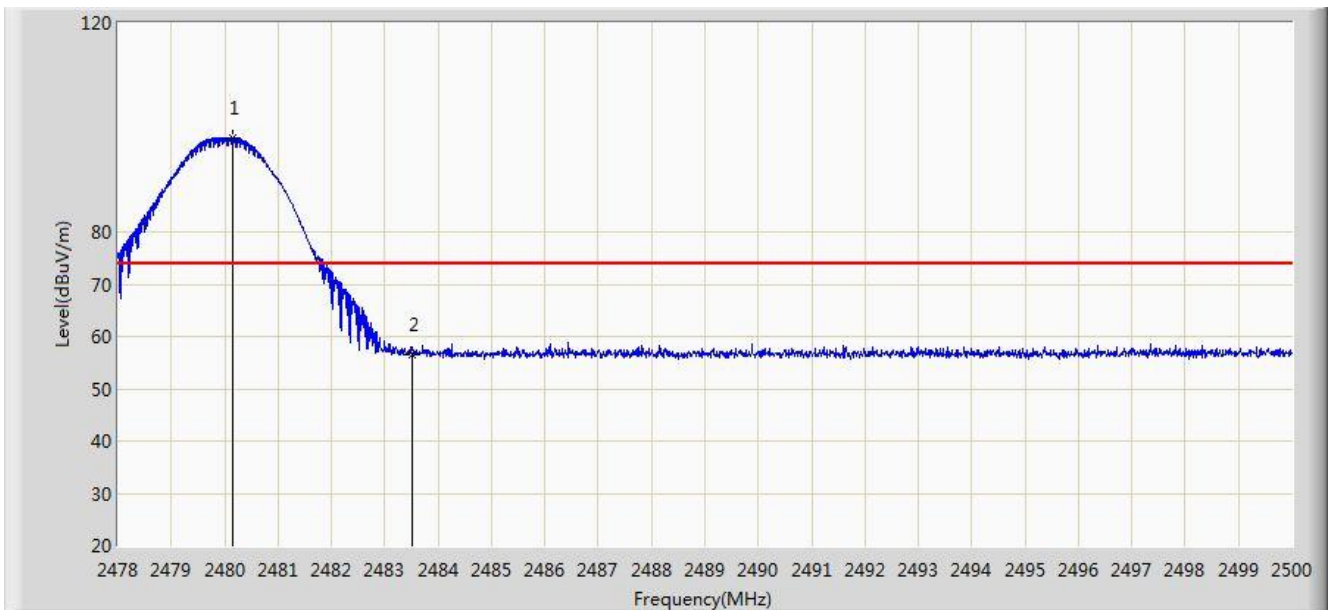

No	Flag	Mark	Frequency (MHz)	Measure Level (dBuV/m)	Reading Level (dBuV)	Over Limit (dB)	Limit (dBuV/m)	Factor (dB)	Type
1		*	2480.156	97.943	66.758	N/A	N/A	31.185	PK
2			2483.500	56.626	25.433	-17.374	74.000	31.194	PK

Note: Measure Level (dB $\mu$ V/m) = Reading Level (dB $\mu$ V) + Factor (dB)

Factor (dB) = Cable Loss (dB) + Antenna Factor (dB/m)

Site: AC1	Time: 2015/03/28 - 20:34
Limit: FCC_Part15.209_RE(3m)	Engineer: Roy Cheng
Probe: BBHA9120D_1-18GHz	Polarity: Vertical
EUT: Tablet PC	Power: AC 120V/60Hz
Test Mode: Transmit at channel 2480MHz By 3DH5	

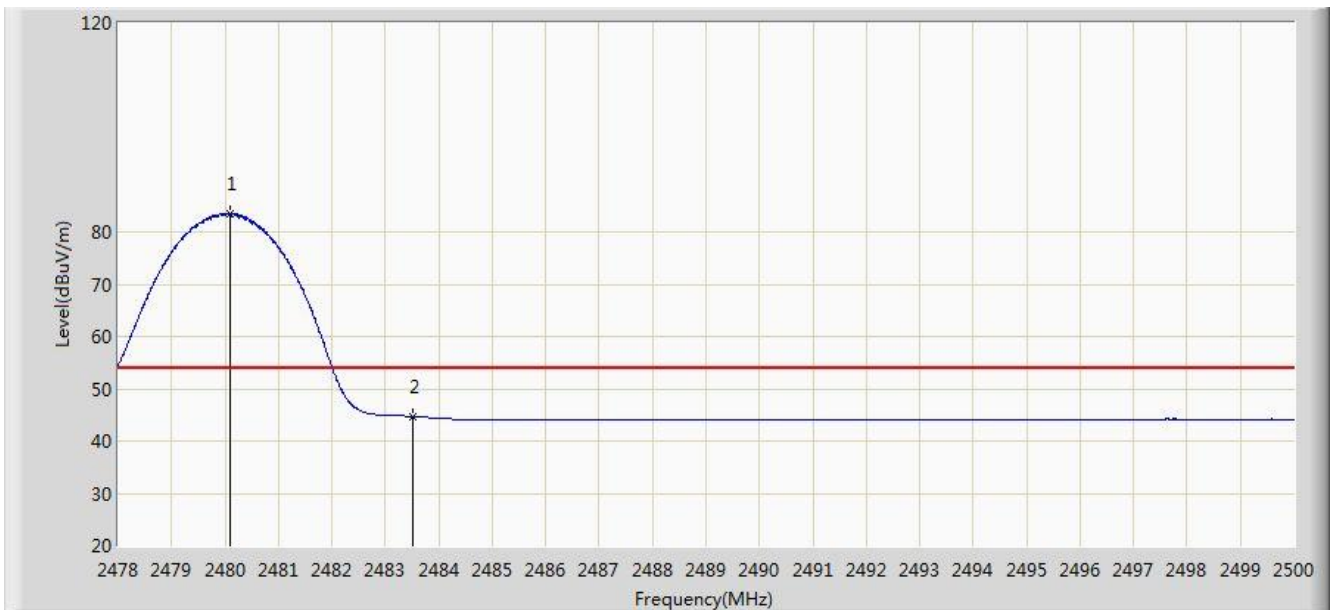

No	Flag	Mark	Frequency (MHz)	Measure Level (dBuV/m)	Reading Level (dBuV)	Over Limit (dB)	Limit (dBuV/m)	Factor (dB)	Type
1		*	2480.090	83.535	52.351	N/A	N/A	31.184	AV
2			2483.500	44.697	13.504	-9.303	54.000	31.194	AV

Note: Measure Level (dB $\mu$ V/m) = Reading Level (dB $\mu$ V) + Factor (dB)

Factor (dB) = Cable Loss (dB) + Antenna Factor (dB/m)

## 7.11. AC Conducted Emissions Measurement

### 7.11.1. Test Limit

FCC Part 15 Subpart C Paragraph 15.207 Limits		
Frequency (MHz)	QP (dB $\mu$ V)	Average (dB $\mu$ V)
0.15 - 0.50	66 - 56	56 - 46
0.50 - 5.0	56	46
5.0 - 30	60	50

Note 1: The lower limit shall apply at the transition frequencies.

Note 2: The limit decreases linearly with the logarithm of the frequency in the range 0.15MHz to 0.5MHz.

### 7.11.2. Test Setup

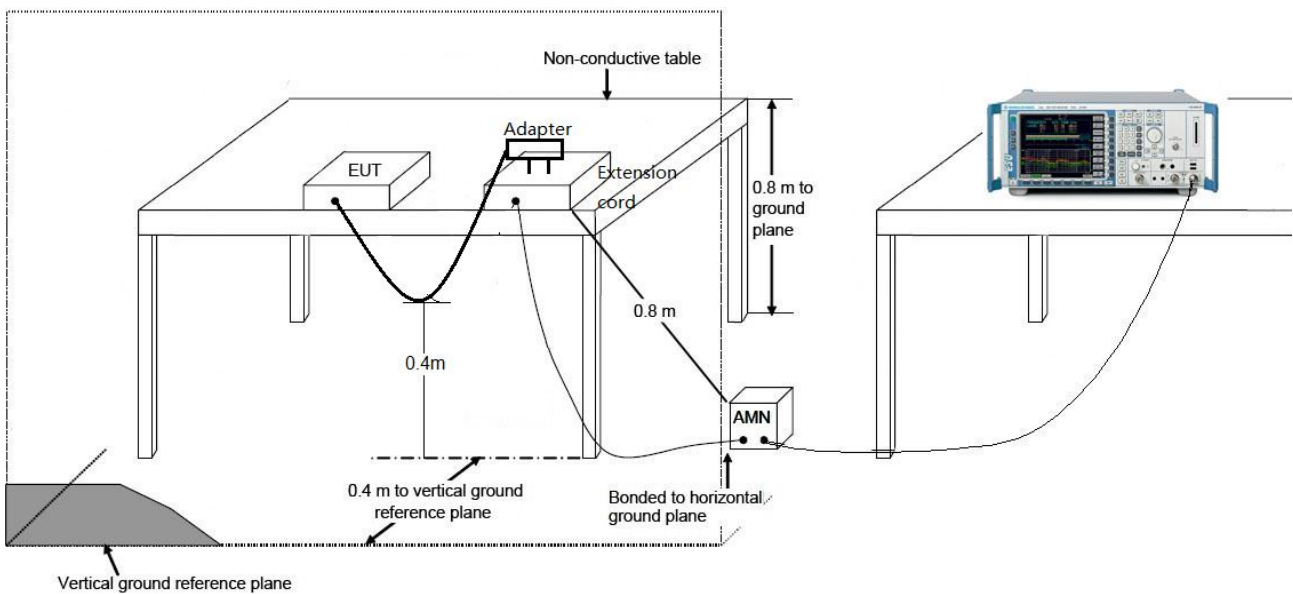

### 7.11.3. Test Result

Site: SR2	Time: 2015/04/02 - 18:05
Limit: FCC_Part15.207_CE_AC Power	Engineer: Roy Cheng
Probe: ENV216_101683_Filter On	Polarity: Line
EUT: Tablet PC	Power: AC 120V/60Hz
Test Mode: 2DH5 at Channel 2480MHz	

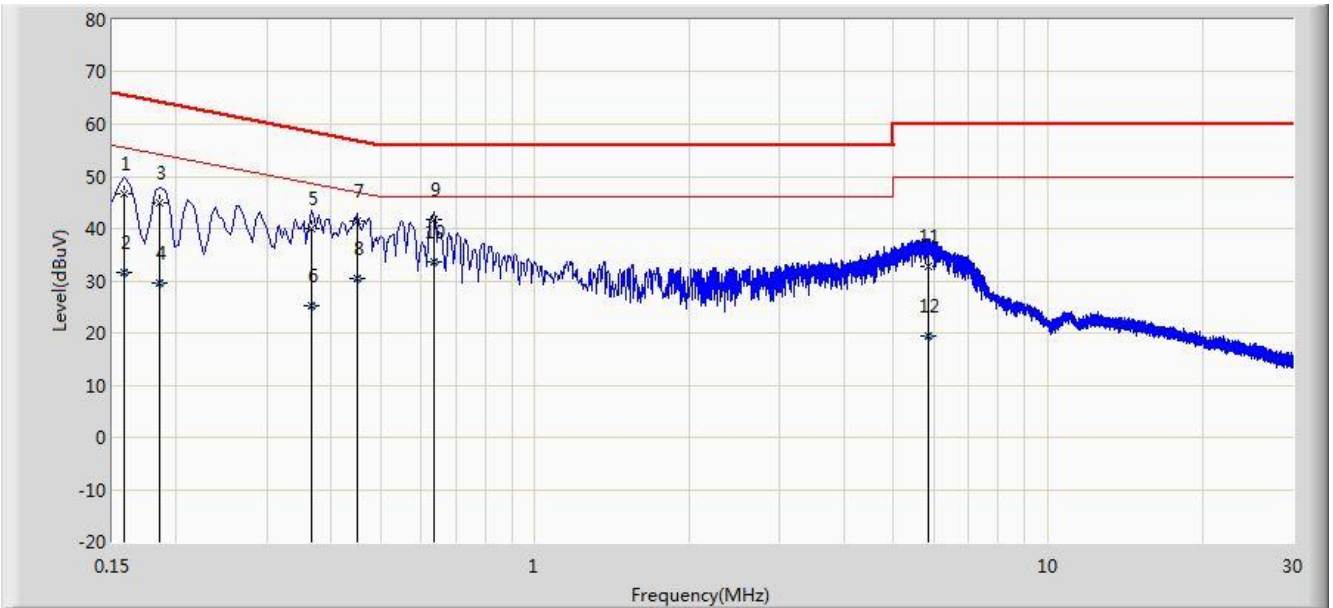

No	Flag	Mark	Frequency (MHz)	Measure Level (dBuV)	Reading Level (dBuV)	Over Limit (dB)	Limit (dBuV)	Factor (dB)	Type
1			0.158	46.652	36.341	-18.916	65.568	10.311	QP
2			0.158	31.517	21.206	-24.052	55.568	10.311	AV
3			0.186	44.999	34.961	-19.214	64.213	10.039	QP
4			0.186	29.567	19.528	-24.646	54.213	10.039	AV
5			0.366	40.017	29.959	-18.574	58.591	10.058	QP
6			0.366	25.084	15.026	-23.507	48.591	10.058	AV
7			0.450	41.411	31.285	-15.464	56.875	10.126	QP
8			0.450	30.435	20.309	-16.440	46.875	10.126	AV
9			0.634	41.874	31.777	-14.126	56.000	10.097	QP
10		*	0.634	33.656	23.559	-12.344	46.000	10.097	AV
11			5.846	32.643	22.547	-27.357	60.000	10.096	QP
12			5.846	19.542	9.446	-30.458	50.000	10.096	AV

Note: Measure Level (dBμV) = Reading Level (dBμV) + Factor (dB)

Factor (dB) = Cable Loss (dB) + LISN Factor (dB)

Site: SR2	Time: 2015/04/02 - 18:12
Limit: FCC_Part15.207_CE_AC Power	Engineer: Roy Cheng
Probe: ENV216_101683_Filter On	Polarity: Neutral
EUT: Tablet PC	Power: AC 120V/60Hz
Test Mode: 2DH5 at Channel 2480MHz	

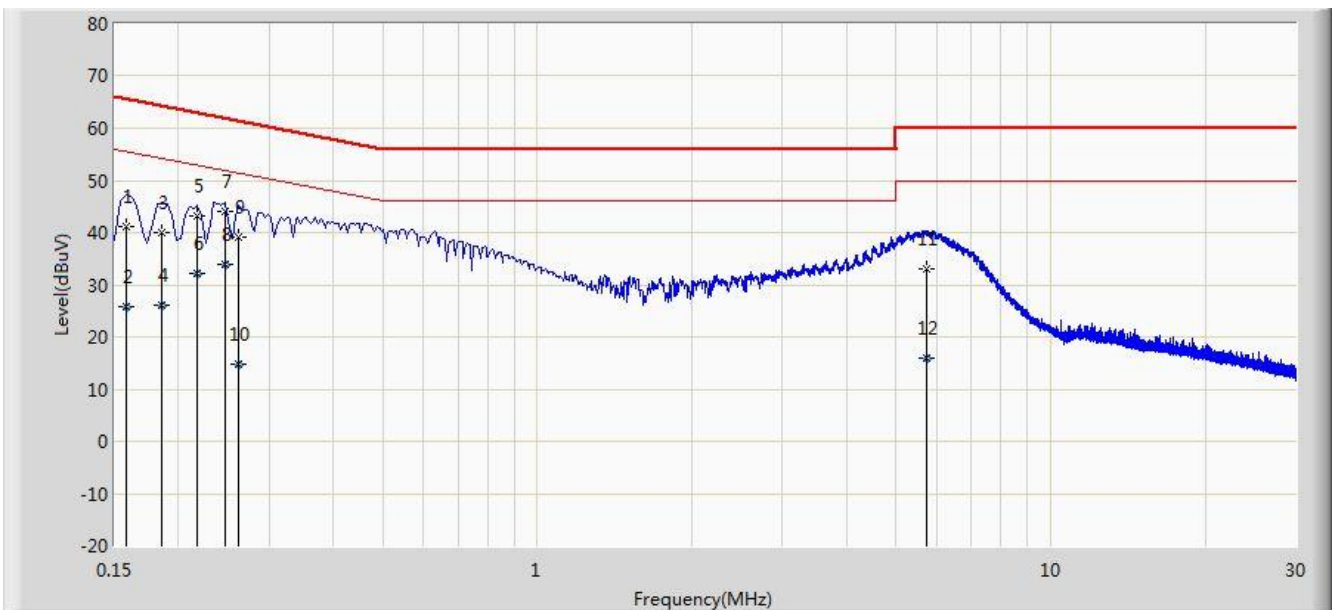

No	Flag	Mark	Frequency (MHz)	Measure Level (dBuV)	Reading Level (dBuV)	Over Limit (dB)	Limit (dBuV)	Factor (dB)	Type
1			0.158	41.035	30.745	-24.534	65.568	10.290	QP
2			0.158	25.708	15.418	-29.861	55.568	10.290	AV
3			0.186	40.004	29.969	-24.210	64.213	10.035	QP
4			0.186	26.009	15.974	-28.204	54.213	10.035	AV
5			0.218	43.214	33.233	-19.681	62.895	9.981	QP
6			0.218	32.108	22.127	-20.787	52.895	9.981	AV
7		*	0.246	44.028	34.030	-17.863	61.891	9.998	QP
8			0.246	33.877	23.879	-18.014	51.891	9.998	AV
9			0.262	39.004	28.994	-22.364	61.368	10.010	QP
10			0.262	14.862	4.852	-36.506	51.368	10.010	AV
11			5.734	32.992	22.880	-27.008	60.000	10.112	QP
12			5.734	15.810	5.697	-34.190	50.000	10.112	AV

Note: Measure Level (dBμV) = Reading Level (dBμV) + Factor (dB)

Factor (dB) = Cable Loss (dB) + LISN Factor (dB)



## 8. CONCLUSION

The data collected relate only the item(s) tested and show that the **Tablet PC FCC ID:**

**WL6-TE69SA3** is in compliance with Part 15C of the FCC Rules.

---

The End