



EMC TEST REPORT

Applicant Centrica Connected Home Limited
FCC ID WJHHCI001
Product Hive View
Model HCI001
Report No. RXA1709-0321EMC
Issue Date October 12, 2017

TA Technology (Shanghai) Co., Ltd. tested the above equipment in accordance with the requirements in **FCC Code CFR47 Part15B (2017)/ ANSI C63.4 (2014)**. The test results show that the equipment tested is capable of demonstrating compliance with the requirements as documented in this report.

Wei Liu

Guangchang Fan

Performed by: Wei Liu/ Manager

Approved by: Guangchang Fan/ Director

TA Technology (Shanghai) Co., Ltd.

No.145, Jintang Rd, Tangzhen Industry Park, Pudong Shanghai, China

TEL: +86-021-50791141/2/3

FAX: +86-021-50791141/2/3-8000



Table of Contents

1	Test Laboratory.....	4
1.1	Notes of the Test Report.....	4
1.2	Test facility.....	4
1.3	Testing Location.....	5
2	General Description of Equipment under Test.....	6
2.1	Client Information.....	6
2.2	General information.....	6
2.3	Applied Standards.....	7
2.4	Test Configuration.....	8
3	Test Case Results.....	9
3.1	Radiated Emission.....	9
3.2	Conducted Emission.....	14
4	Main Test Instrument.....	16
	ANNEX A: The EUT Appearance and Test Configuration.....	17
	A.1 EUT Appearance.....	17
	A.2 Test Setup.....	21
	A.3 Host Product.....	23



Summary of measurement results

Number	Test Case	Clause in FCC Rules	Conclusion
1	Radiated Emission	15.109, ANSI C63.4-2014	PASS
2	Conducted Emission	15.107, ANSI C63.4-2014	PASS
Date of Testing: September 13, 2017~ September 27, 2017			

1 Test Laboratory

1.1 Notes of the Test Report

This report shall not be reproduced in full or partial, without the written approval of **TA technology (shanghai) co., Ltd.** The results documented in this report apply only to the tested sample, under the conditions and modes of operation as described herein .Measurement Uncertainties were not taken into account and are published for informational purposes only. This report is written to support regulatory compliance of the applicable standards stated above. This report must not be used by the client to claim product certification, approval, or endorsement any government agencies.

1.2 Test facility

CNAS (accreditation number: L2264)

TA Technology (Shanghai) Co., Ltd. has obtained the accreditation of China National Accreditation Service for Conformity Assessment (CNAS).

FCC (Designation number: CN1179, Test Firm Registration Number: 446626)

TA Technology (Shanghai) Co., Ltd. has been listed on the US Federal Communications Commission list of test facilities recognized to perform electromagnetic emissions measurements.

IC (recognition number is 8510A)

TA Technology (Shanghai) Co., Ltd. has been listed by industry Canada to perform electromagnetic emission measurement.

VCCI (recognition number is C-4595, T-2154, R-4113, G-10766)

TA Technology (Shanghai) Co., Ltd. has been listed by industry Japan to perform electromagnetic emission measurement.

A2LA (Certificate Number: 3857.01)

TA Technology (Shanghai) Co., Ltd. has been listed by American Association for Laboratory Accreditation to perform electromagnetic emission measurement.



1.3 Testing Location

Company: TA Technology (Shanghai) Co., Ltd.
Address: No.145, Jintang Rd, Tangzhen Industry Park, Pudong Shanghai, China
City: Shanghai
Post code: 201201
Country: P. R. China
Contact: Xu Kai
Telephone: +86-021-50791141/2/3
Fax: +86-021-50791141/2/3-8000
Website: <http://www.ta-shanghai.com>
E-mail: xukai@ta-shanghai.com

2 General Description of Equipment under Test

2.1 Client Information

Applicant	Centrica Connected Home Limited
Applicant address	Millstream, Maidenhead Road, Windsor, Berkshire SL4 5GD United Kingdom
Manufacturer	Centrica Connected Home Limited
Manufacturer address	Millstream, Maidenhead Road, Windsor, Berkshire SL4 5GD United Kingdom

2.2 General information

EUT Description	
Device Type:	Portable Device
Product Name:	Hive View
Model Number:	HCI001
HW Version:	EP-VBC01MB-05
SW Version:	v0.0.00.037
Antenna Type:	Internal Antenna
Used Host Product:	PC Manufacturer: Dell Model: E5430 (SN : R98M9 A02)
Test Mode:	Transfer Data Mode
EUT Accessory	
Adapter 1--US	Manufacture: Centrica Connected Home Limited Model : HPA001
Adapter 2--EU	Manufacture: Centrica Connected Home Limited Model : HPA001
Adapter 3--UK	Manufacture: Centrica Connected Home Limited Model : HPA001
Pedestal Accessory	Model :MPDVBC01-Z
Remark: The information of the EUT is declared by the manufacturer.	



2.3 Applied Standards

According to the specifications of the manufacturer, it must comply with the requirements of the following standards:

Test standards

FCC Code CFR47 Part15B (2017)

ANSI C63.4 (2014)

2.4 Test Configuration

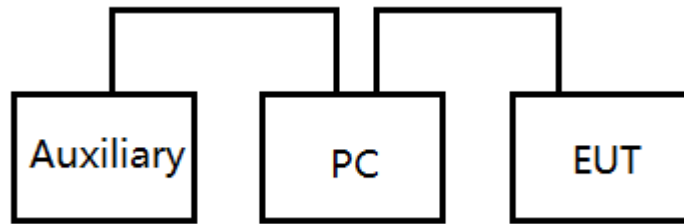

3 Test Case Results

3.1 Radiated Emission

Ambient condition

Temperature	Relative humidity	Pressure
24°C~26°C	45%~50%	102.5kPa

Methods of Measurement

The EUT is placed on a non-metallic table 0.8m above the horizontal metal reference ground plane. The distance between EUT and receive antenna should be 3 meters. During the test, the EUT was operating in its typical mode. The test method is according to ANSI C63.4-2014. Sweep the whole frequency band through the range from 30MHz to the 5th harmonic of the carrier. During the test, the height of receive antenna shall be moved from 1 to 4 meters, and the antenna shall be performed under horizontal and vertical polarization. The turn table shall be rotated from 0 to 360 degrees for detecting the maximum of radiated signal level.

The data of cable loss and antenna factor has been calibrated in full testing frequency range before the testing. During the test, the EUT is worked at maximum output power.

Set the spectrum analyzer in the following:

Below 1GHz:

RBW=100 kHz / VBW=300 kHz / Sweep=AUTO

Above 1GHz:

(a) PEAK: RBW=1MHz / VBW=3MHz/ Sweep=AUTO

(b) AVERAGE: RBW=1MHz / VBW=3MHz / Sweep=AUTO

The radiated emission was measured in the following position: EUT stand-up position (Z axis), lie-down position (X, Y axis). The worst emission was found in stand-up position (Z axis) and the worst case was recorded.

During the test, EUT is connected to a laptop via a USB cable in the case of Transfer Data mode. The EUT is used as the peripheral equipment of the PC and telephone. The data is transferred from EUT to PC; PC is connected to server via a long LAN cable.

Test Setup

Below 1GHz

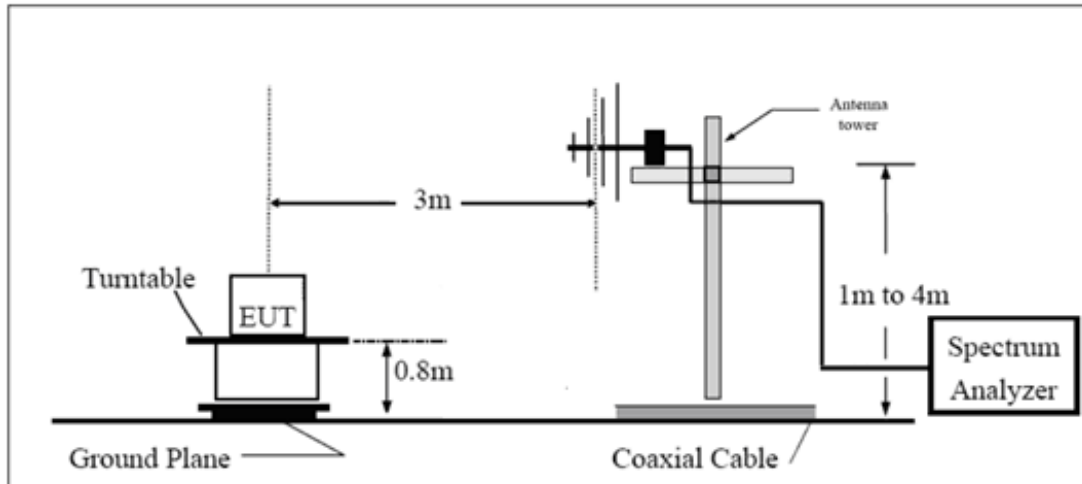

Above 1GHz

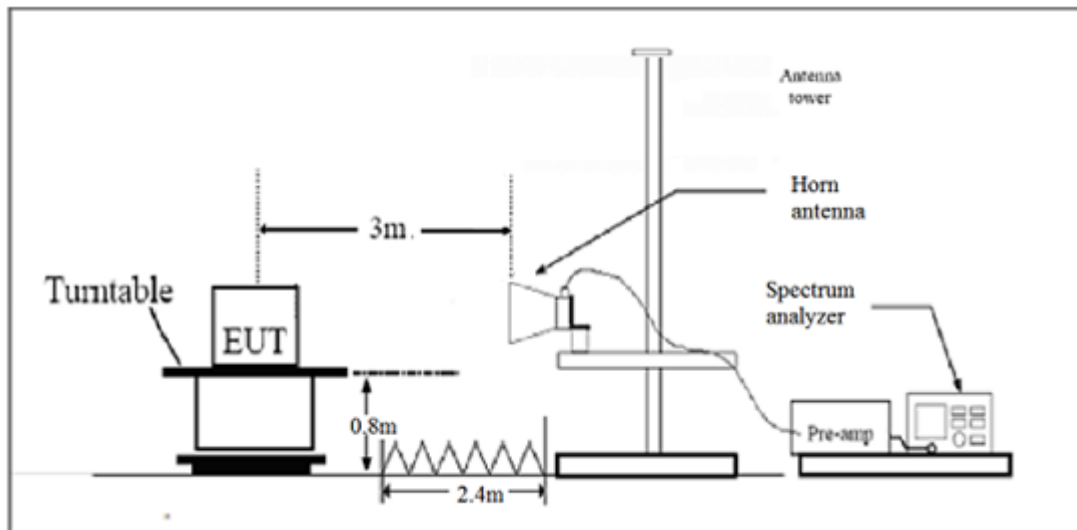

Note: Area side:2.4mX3.6m

Antenna Tower meets ANSI C63.4 requirements for measurements above 1 GHz by keeping the antenna aimed at the EUT during the antenna's ascent/ descent along the antenna mast.

Limits

Frequency (MHz)	Field Strength (dB μ V/m)	Detector
30 -88	40.0	Quasi-peak
88-216	43.5	Quasi-peak
216 – 960	46.0	Quasi-peak
960-1000	54.0	Quasi-peak
1000-5 th harmonic of the highest frequency or 40GHz, which is lower	54 74	Average Peak

Measurement Uncertainty

The assessed measurement uncertainty to ensure 95% confidence level for the normal distribution is with the coverage factor $k = 1.96$. $U = 3.92$ dB.

Test Results

The following graphs display the maximum values of horizontal and vertical by software.
 For above 1GHz, Blue trace uses the peak detection, Green trace uses the average detection.

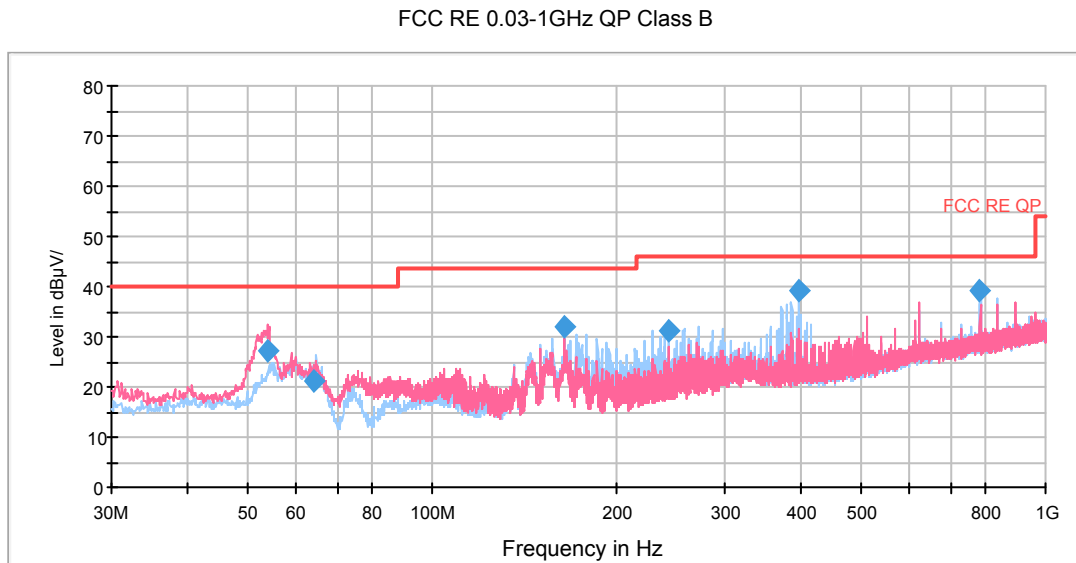

Radiated Emission from 30MHz to 1GHz

Frequency (MHz)	Quasi-Peak (dBuV/m)	Reading value (dBuV/m)	Height (cm)	Polarization	Azimuth (deg)	Correct Factor (dB)	Margin (dB)	Limit (dBuV/m)
53.806250	27.1	14.3	100.0	V	77.0	12.8	12.9	40.0
64.318750	21.2	10.2	225.0	H	150.0	11.0	18.8	40.0
164.463750	32.1	22.1	125.0	H	239.0	10.0	11.4	43.5
242.996250	31.3	17.2	100.0	H	227.0	14.1	14.7	46.0
396.013750	39.2	20.9	100.0	H	102.0	18.3	6.8	46.0
783.003750	39.3	14.2	100.0	H	136.0	25.1	6.7	46.0

- Remark:**
1. Quasi-Peak = Reading value + Correction factor
 2. Correction Factor = Antenna factor+ Insertion loss(cable loss+amplifier gain)
 3. Margin = Limit – Quasi-Peak

FCC RE 1G-18GHz PK+AV Class B

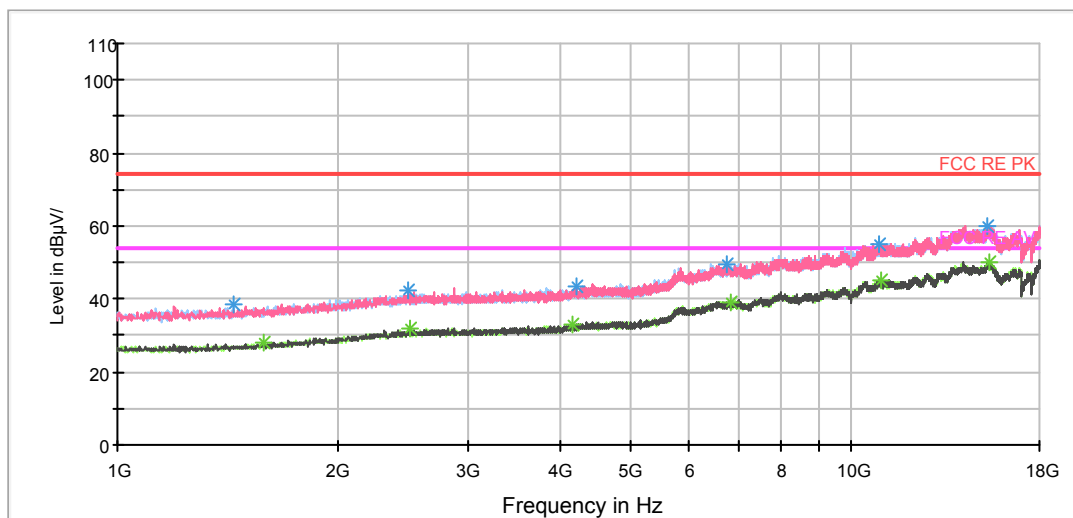

Radiated Emission from 1GHz to 6GHz

Frequency (MHz)	Peak (dBuV/m)	Reading value (dBuV/m)	Height (cm)	Polarization	Azimuth (deg)	Correct Factor (dB)	Margin (dB)	Limit (dBuV/m)
1437.750000	38.2	44.9	100.0	H	354.0	-6.7	35.8	74
2489.625000	42.5	43.4	100.0	V	56.0	-0.9	31.5	74
4217.250000	43.4	42.2	100.0	H	342.0	1.2	30.6	74
6771.500000	49.7	42.6	100.0	H	0.0	7.1	24.3	74
10911.000000	55.2	42.2	100.0	V	128.0	13.0	18.8	74
15326.750000	60.1	41.9	100.0	H	0.0	18.2	13.9	74

Frequency (MHz)	Average (dBuV/m)	Reading value (dBuV/m)	Height (cm)	Polarization	Azimuth (deg)	Correct Factor (dB)	Margin (dB)	Limit (dBuV/m)
1578.000000	27.9	33.9	100.0	V	41.0	-6.0	26.1	54
2496.000000	31.8	32.7	100.0	H	262.0	-0.9	22.2	54
4159.875000	33.1	31.8	100.0	V	99.0	1.3	20.9	54
6818.250000	39.2	31.9	100.0	H	0.0	7.3	14.8	54
10936.500000	45.3	32.3	100.0	V	278.0	13.0	8.7	54
15352.250000	50.1	31.7	100.0	H	319.0	18.4	3.9	54

3.2 Conducted Emission

Ambient condition

Temperature	Relative humidity	Pressure
24°C ~26°C	50%~55%	102.5kPa

Methods of Measurement

The EUT is placed on a non-metallic table of 80cm height above the horizontal metal reference ground plane. During the test, the EUT was operating in its typical mode. The test method is according to ANSI C63.4-2014. Connect the AC power line of the EUT to the L.I.S.N. Use EMI receiver to detect the average and Quasi-peak value. RBW is set to 9 kHz, VBW is set to 30kHz. The measurement result should include both L line and N line.

During the test, EUT is connected to a laptop via a USB cable in the case of Transfer Data mode. The EUT is used as the peripheral equipment of the PC and telephone. The data is transferred from EUT to PC; PC is connected to server via a long LAN cable.

Test Setup

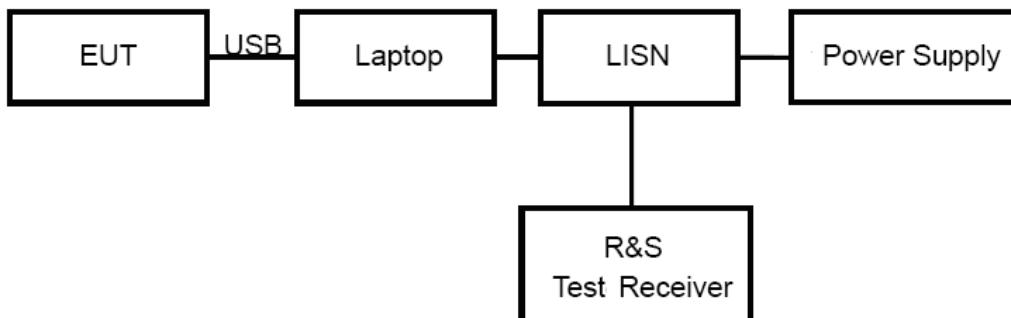

Note: Power Supply is AC Power source and it is used to change the voltage 120V/60Hz.

Limits

Frequency (MHz)	Conducted Limits(dBμV)	
	Quasi-peak	Average
0.15 - 0.5	66 to 56 *	56 to 46 *
0.5 - 5	56	46
5 - 30	60	50

*: Decreases with the logarithm of the frequency.

Measurement Uncertainty

The assessed measurement uncertainty to ensure 95% confidence level for the normal distribution is with the coverage factor $k = 1.96$. $U = 2.69$ dB.

Test Results

Following plots, Blue trace uses the peak detection; Green trace uses the average detection.

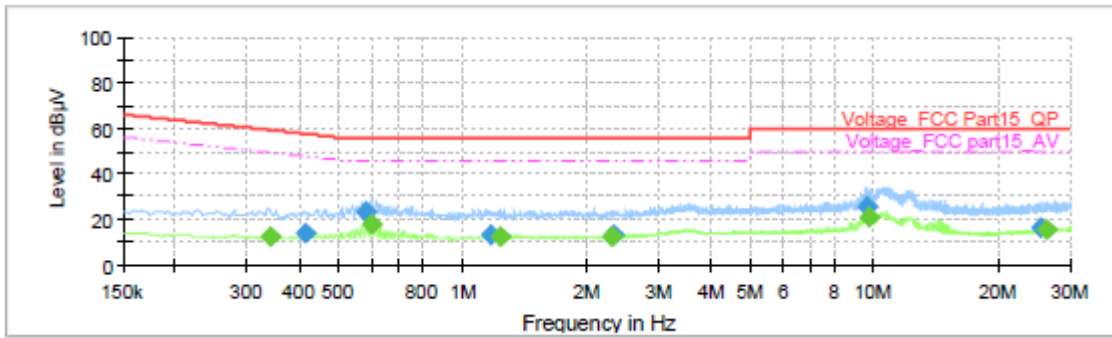

Frequency (MHz)	QuasiPeak (dBµV)	Average (dBµV)	Limit (dBµV)	Margin (dB)	Meas. Time (ms)	Bandwidth (kHz)	Line	Filter	Corr. (dB)
0.339000	---	12.27	49.23	36.96	1000.0	9.000	L1	ON	19.2
0.413250	13.59	---	57.58	44.00	1000.0	9.000	L1	ON	19.2
0.584250	23.52	---	56.00	32.48	1000.0	9.000	L1	ON	19.3
0.600000	---	18.20	46.00	27.80	1000.0	9.000	L1	ON	19.3
1.173750	12.93	---	56.00	43.07	1000.0	9.000	L1	ON	19.2
1.230000	---	12.63	46.00	33.37	1000.0	9.000	L1	ON	19.2
2.314500	---	12.03	46.00	33.97	1000.0	9.000	L1	ON	19.0
2.330250	12.99	---	56.00	43.01	1000.0	9.000	L1	ON	19.0
9.674250	25.78	---	60.00	34.22	1000.0	9.000	L1	ON	19.4
9.750750	---	20.73	50.00	29.27	1000.0	9.000	L1	ON	19.4
25.541250	16.00	---	60.00	44.00	1000.0	9.000	L1	ON	19.8
26.184750	---	15.47	50.00	34.53	1000.0	9.000	L1	ON	19.9

L line

Conducted Emission from 150 KHz to 30 MHz

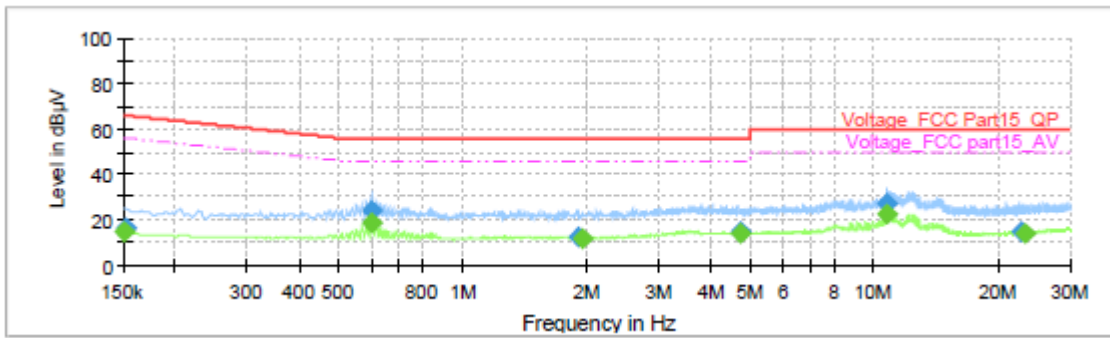

Frequency (MHz)	QuasiPeak (dBµV)	Average (dBµV)	Limit (dBµV)	Margin (dB)	Meas. Time (ms)	Bandwidth (kHz)	Line	Filter	Corr. (dB)
0.150000	---	14.63	56.00	41.37	1000.0	9.000	N	ON	19.1
0.152250	16.00	---	65.88	49.88	1000.0	9.000	N	ON	19.1
0.600000	---	18.46	46.00	27.54	1000.0	9.000	N	ON	19.3
0.600000	24.34	---	56.00	31.66	1000.0	9.000	N	ON	19.3
1.909500	12.72	---	56.00	43.28	1000.0	9.000	N	ON	19.2
1.963500	---	11.91	46.00	34.09	1000.0	9.000	N	ON	19.1
4.737750	---	13.75	46.00	32.25	1000.0	9.000	N	ON	19.1
4.740000	14.86	---	56.00	41.14	1000.0	9.000	N	ON	19.1
10.729500	---	22.43	50.00	27.57	1000.0	9.000	N	ON	19.4
10.731750	27.24	---	60.00	32.76	1000.0	9.000	N	ON	19.4
22.713000	14.89	---	60.00	45.11	1000.0	9.000	N	ON	19.5
23.293500	---	14.05	50.00	35.95	1000.0	9.000	N	ON	19.6

N line

Conducted Emission from 150 KHz to 30 MHz

4 Main Test Instrument

Name	Manufacturer	Type	Serial Number	Last Cal.	Cal. Due Date
Signal Analyzer	R&S	FSV30	100815	2016-12-16	2017-12-15
EMI Test Receiver	R&S	ESCI	100948	2017-05-20	2018-05-19
Loop Antenna	SCHWARZBECK	FMZB1519	1519-047	2017-02-18	2019-02-17
Trilog Antenna	SCHWARZBECK	VULB 9163	9163-201	2014-12-06	2017-12-05
Horn Antenna	R&S	HF907	100126	2014-12-06	2017-12-05
Horn Antenna	ETS-Lindgren	3160-09	00102643	2015-01-30	2018-01-29
EMI Test Receiver	R&S	ESCS30	100138	2016-12-16	2017-12-15
LISN	R&S	ENV216	101171	2016-12-16	2019-12-15
Bore Sight Antenna mast	ETS	2171B	00058752	NA	NA

ANNEX A: The EUT Appearance and Test Configuration

A.1 EUT Appearance



EUT



EUT with Pedestal Accessory
a: EUT



Adapter 1



Adapter 2

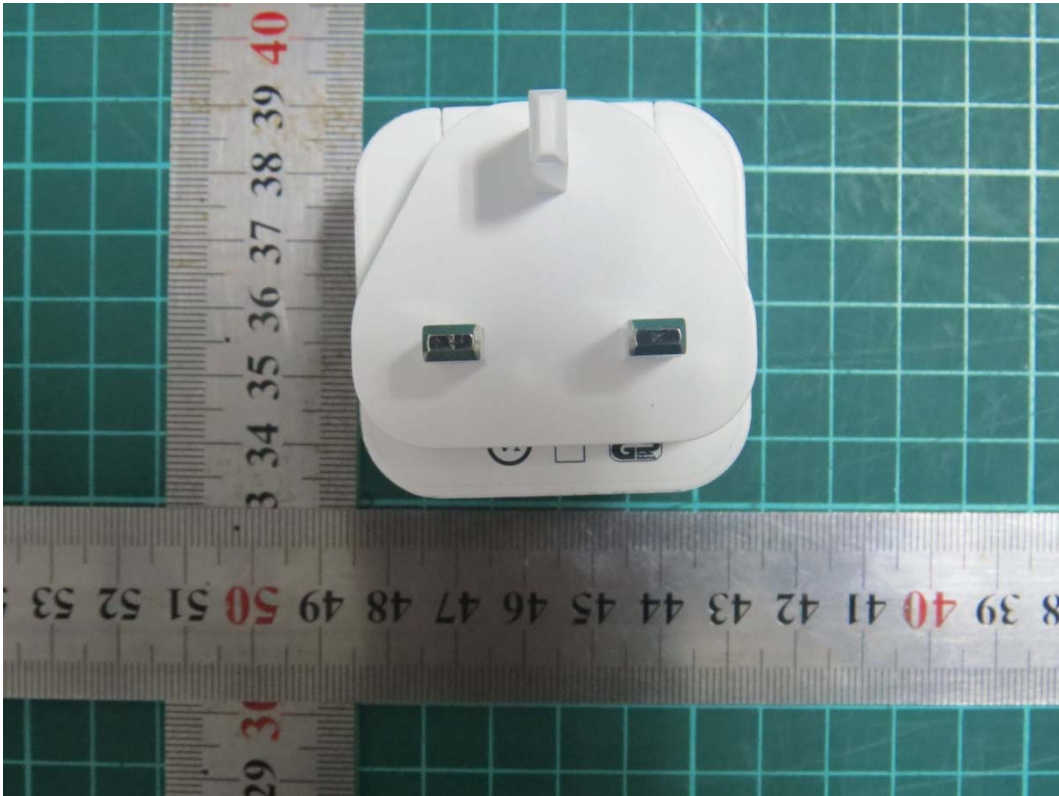

Adapter 3
b: Adapter

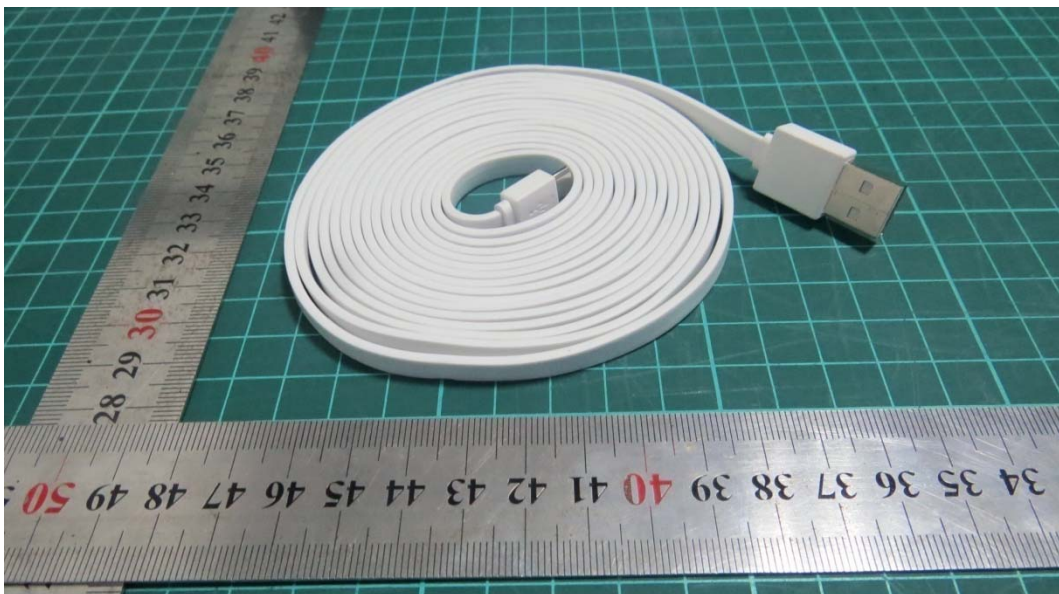

c: USB Cable
Picture 1 EUT

A.2 Test Setup

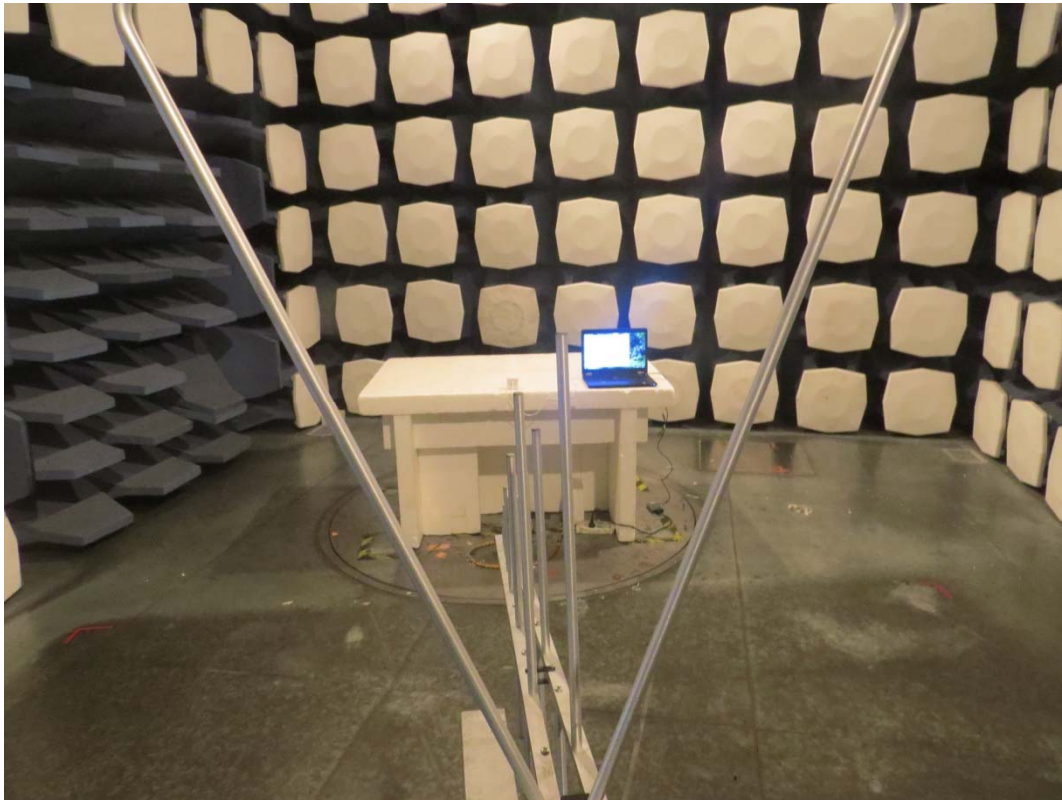

a: Below 1GHz



b: Above 1GHz

Picture 2 Radiated Emission Test Setup

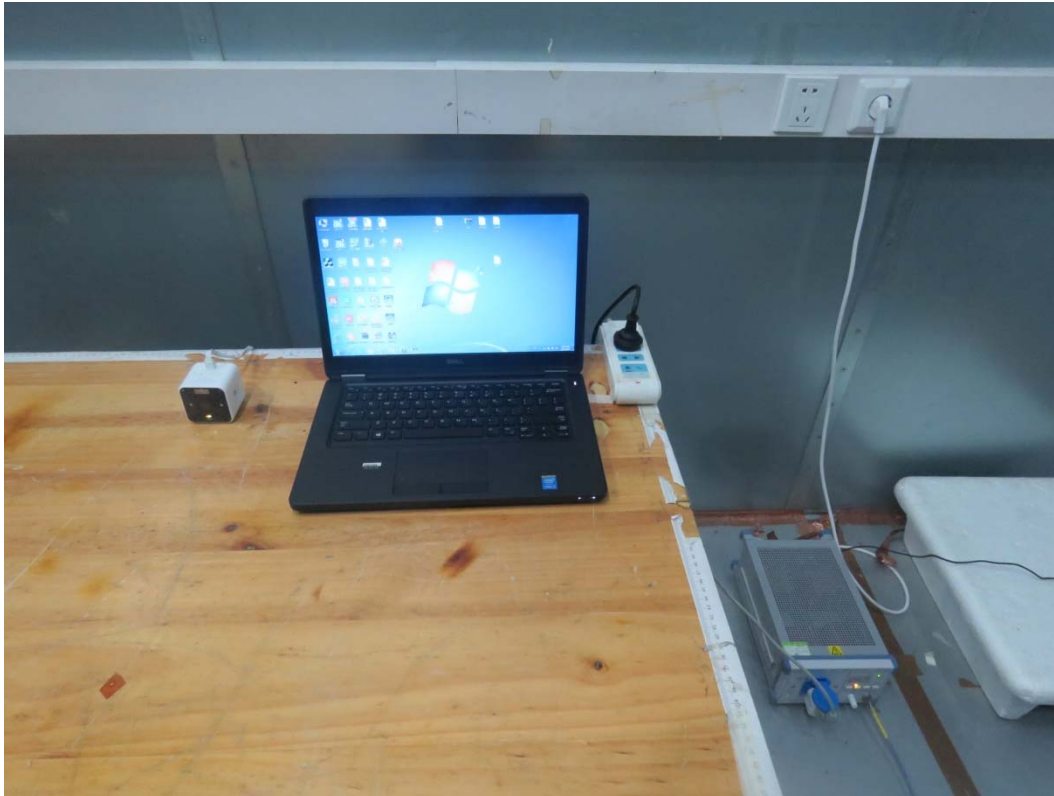

Picture 3 Conducted Emission Test Setup

A.3 Host Product

