



RF TEST REPORT

Applicant Centrica Connected Home Limited
FCC ID WJHHCI001
Product Hive View
Brand Hive
Model HCI001
Report No. RXA1709-0321RF01
Issue Date October 12, 2017

TA Technology (Shanghai) Co., Ltd. tested the above equipment in accordance with the requirements in **FCC CFR47 Part 15E (2017)**. The test results show that the equipment tested is capable of demonstrating compliance with the requirements as documented in this report.

Performed by: Xianqing Li

Approved by: Kai Xu

TA Technology (Shanghai) Co., Ltd.

No.145, Jintang Rd, Tangzhen Industry Park, Pudong Shanghai, China

TEL: +86-021-50791141/2/3

FAX: +86-021-50791141/2/3-8000



TABLE OF CONTENT

1. Test Laboratory	4
1.1. Notes of the test report.....	4
1.2. Test facility	4
1.3. Testing Location.....	5
2. General Description of Equipment under Test.....	6
3. Applied Standards	8
4. Test Configuration	9
5. Test Case Results	10
5.1. Occupied Bandwidth	10
5.2. Average Power Output –Conducted.....	28
5.3. Frequency Stability.....	32
5.4. Power Spectral Density	36
5.5. Unwanted Emission	51
5.6. Conducted Emission	237
6. Main Test Instruments.....	239
ANNEX A: EUT Appearance and Test Setup	240
A.1 EUT Appearance	240
A.2 Test Setup	244



Summary of measurement results

Number	Summary of measurements of results	Clause in FCC rules	Verdict
1	Average conducted output power	15.407(a)	PASS
2	Occupied bandwidth	15.407(e)	PASS
3	Frequency stability	15.407(g)	PASS
4	Maximum power spectral density	15.407(a)	PASS
5	Unwanted Emissions	15.407(b)	PASS
6	Conducted Emissions	15.207	PASS
Date of Testing: September 13, 2017~ September 27, 2017			



1. Test Laboratory

1.1. Notes of the test report

This report shall not be reproduced in full or partial, without the written approval of **TA technology (shanghai) co., Ltd.** The results documented in this report apply only to the tested sample, under the conditions and modes of operation as described herein. Measurement Uncertainties were not taken into account and are published for informational purposes only. This report is written to support regulatory compliance of the applicable standards stated above. This report must not be used by the client to claim product certification, approval, or endorsement by any government agencies.

1.2. Test facility

CNAS (accreditation number: L2264)

TA Technology (Shanghai) Co., Ltd. has obtained the accreditation of China National Accreditation Service for Conformity Assessment (CNAS).

FCC (Designation number: CN1179, Test Firm Registration Number: 446626)

TA Technology (Shanghai) Co., Ltd. has been listed on the US Federal Communications Commission list of test facilities recognized to perform electromagnetic emissions measurements.

IC (recognition number is 8510A)

TA Technology (Shanghai) Co., Ltd. has been listed by industry Canada to perform electromagnetic emission measurement.

VCCI (recognition number is C-4595, T-2154, R-4113, G-10766)

TA Technology (Shanghai) Co., Ltd. has been listed by industry Japan to perform electromagnetic emission measurement.

A2LA (Certificate Number: 3857.01)

TA Technology (Shanghai) Co., Ltd. has been listed by American Association for Laboratory Accreditation to perform electromagnetic emission measurement.



1.3. Testing Location

Company: TA Technology (Shanghai) Co., Ltd.
Address: No.145, Jintang Rd, Tangzhen Industry Park, Pudong
City: Shanghai
Post code: 201201
Country: P. R. China
Contact: Xu Kai
Telephone: +86-021-50791141/2/3
Fax: +86-021-50791141/2/3-8000
Website: <http://www.ta-shanghai.com>
E-mail: xukai@ta-shanghai.com



2. General Description of Equipment under Test

Client Information

Applicant	Centrica Connected Home Limited
Applicant address	Millstream, Maidenhead Road, Windsor, Berkshire SL4 5GD United Kingdom
Manufacturer	Centrica Connected Home Limited
Manufacturer address	Millstream, Maidenhead Road, Windsor, Berkshire SL4 5GD United Kingdom

General information

EUT Description	
Model:	HCI001
SN:	HCI001YYWW-000000
Hardware Version:	EP-VBC01MB-05
Software Version:	v0.0.00.037
Power Supply:	AC Power Supply
Antenna Type:	Internal Antenna
Antenna Gain:	Antenna : 2 dBi
additional beamforming gain:	0 dB
Test Mode:	U-NII-1(5150MHz-5250MHz) U-NII-2A(5250MHz-5350MHz) U-NII-2C(5470MHz-5725MHz) U-NII-3(5725MHz-5850MHz)
Modulation Type:	802.11a/n (HT20/HT40) : OFDM 802.11ac (HT20.HT40/HT80): OFDM
Max. Conducted Power	15.24 dBm
Operating Frequency Range(s)	U-NII-1: 5150-5250MHz U-NII-2A:5250-5350MHz U-NII-2C:5470-5725MHz (with 5600MHz -5650MHz) U-NII-3: 5725-5850MHz
EUT Accessory	
Adapter 1--US	Manufacture: Centrica Connected Home Limited Model : HPA001
Adapter 2--EU	Manufacture: Centrica Connected Home Limited Model : HPA001
Adapter 3--UK	Manufacture: Centrica Connected Home Limited Model : HPA001
Pedestal Accessory	Model :MPDVBC01-Z
Note: The information of the EUT is declared by the manufacturer.	



3. Applied Standards

According to the specifications of the manufacturer, it must comply with the requirements of the following standards:

FCC CFR47 Part 15E (2017) Unlicensed National Information Infrastructure Devices

ANSI C63.10 (2013)

KDB 789033 D02 General UNII Test Procedures New Rules v01r04

KDB 662911 D01 Multiple Transmitter Output v02r01

4. Test Configuration

Test Mode

The EUT was programmed to be in continuously transmitting mode and the transmit duty cycle is not less than 98%.

The EUT has been associated with peripherals and configuration operated in a manner tended to maximize its emission characteristics in a typical application.

The radiated emission was measured in the following position: EUT stand-up position (Z axis), lie-down position (X, Y axis). The worst emission was found in stand-up position (Z axis) and the worst case was recorded.

In order to find the worst case condition, Pre-tests are needed at the presence of different data rate. Preliminary tests have been done on all the configuration for confirming worst case. Data rate below means worst-case rate of each test item.

Worst-case data rates are shown as following table.

Band	Data Rate
802.11a	6 Mbps
802.11n HT20	MCS0
802.11n HT40	MCS0
802.11ac HT20	MCS0
802.11ac HT40	MCS0
802.11ac HT80	MCS0

The device supports non-beamforming and beamforming function in 802.11n/ac, after pre-testing, beamforming mode has the worst emission value, so the worst case was recorded.

Band	T _{on} (ms)	T _(on+off) (ms)	Duty cycle	Duty cycle correction Factor(dB)
802.11a	1344	1440	0.933	0.300
802.11n HT20	1920	2016	0.952	0.212
802.11n HT40	1344	1440	0.933	0.300
802.11ac HT20	944	1040	0.908	0.421
802.11ac HT40	664	768	0.865	0.632
802.11ac HT80	332	432	0.769	1.143

Note: when Duty cycle>0.98, Duty cycle correction Factor not required.

5. Test Case Results

5.1. Occupied Bandwidth

Ambient condition

Temperature	Relative humidity	Pressure
23°C ~25°C	45%~50%	101.5kPa

Method of Measurement

The EUT was connected to the spectrum analyzer through an external attenuator (20dB) and a known loss cable.

For U-NII-1, set RBW \approx 1% OCB kHz, VBW \geq 3 \times RBW, measure the maximum width of the emission that is constrained by the frequencies associated with the two outermost amplitude points (upper and lower frequencies) that are attenuated by 26 dB relative to the maximum level measured in the fundamental emission.

For U-NII-3, Set RBW = 100 kHz, VBW \geq 3 \times RBW, measure the maximum width of the emission that is constrained by the frequencies associated with the two outermost amplitude points (upper and lower frequencies) that are attenuated by 6 dB relative to the maximum level measured in the fundamental emission.

Note: The automatic bandwidth measurement capability of a spectrum analyzer or EMI receiver may be employed if it implements the functionality described above.

Use the 99 % power bandwidth function of the instrument

Test Setup

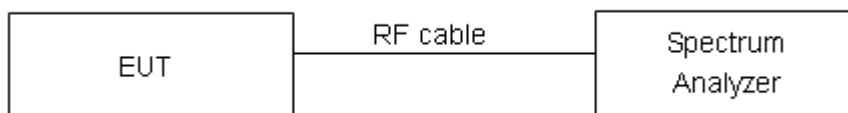

Limits

Rule FCC Part §15.407(e)

Within the 5.725-5.85 GHz band, the minimum 6 dB bandwidth of U-NII devices shall be at least 500 kHz.

Measurement Uncertainty

The assessed measurement uncertainty to ensure 95% confidence level for the normal distribution is with the coverage factor $k = 2$, $U = 936$ Hz.

**Test Results:****U-NII-1**

Network Standards	Carrier frequency (MHz)	99% bandwidth (MHz)	Minimum 26 dB bandwidth (MHz)	Limit (kHz)	Conclusion
802.11a	5180	16.799	25.09	500	PASS
	5200	16.813	22.46	500	PASS
	5240	16.793	23.54	500	PASS
802.11n HT20	5180	18.419	30.00	500	PASS
	5200	18.372	29.94	500	PASS
	5240	18.375	30.00	500	PASS
802.11n HT40	5190	36.386	53.94	500	PASS
	5230	36.317	50.41	500	PASS
802.11ac HT20	5180	17.907	25.45	500	PASS
	5200	17.868	27.18	500	PASS
	5240	17.851	22.46	500	PASS
802.11ac HT40	5190	36.302	50.44	500	PASS
	5230	36.310	50.52	500	PASS
802.11ac HT80	5210	75.820	92.04	500	PASS

U-NII-2A

Network Standards	Carrier frequency (MHz)	99% bandwidth (MHz)	Minimum 26 dB bandwidth (MHz)	Limit (kHz)	Conclusion
802.11a	5260	16.885	25.22	500	PASS
	5300	16.968	28.12	500	PASS
	5320	16.982	28.73	500	PASS
802.11n HT20	5260	18.597	30.00	500	PASS
	5300	18.683	30.00	500	PASS
	5320	18.785	30.00	500	PASS
802.11n HT40	5270	36.457	57.58	500	PASS
	5310	36.384	55.57	500	PASS
802.11ac HT20	5260	17.894	27.94	500	PASS
	5300	17.909	26.69	500	PASS
	5320	17.893	26.71	500	PASS
802.11ac HT40	5270	36.383	54.15	500	PASS
	5310	36.417	59.50	500	PASS
802.11ac HT80	5290	75.722	108.30	500	PASS



U-NII-2C

Network Standards	Carrier frequency (MHz)	99% bandwidth (MHz)	Minimum 26 dB bandwidth (MHz)	Limit (kHz)	Conclusion
802.11a	5500	16.740	24.61	500	PASS
	5580	16.866	26.70	500	PASS
	5700	16.794	22.98	500	PASS
802.11n HT20	5500	18.113	30.00	500	PASS
	5580	18.070	29.86	500	PASS
	5700	18.136	29.980	500	PASS
802.11n HT40	5510	36.144	51.22	500	PASS
	5670	36.284	46.85	500	PASS
802.11ac HT20	5500	17.889	26.08	500	PASS
	5580	17.861	24.08	500	PASS
	5700	17.877	26.67	500	PASS
802.11ac HT40	5510	36.303	42.67	500	PASS
	5670	36.335	50.11	500	PASS
802.11ac HT80	5530	75.696	95.39	500	PASS
	5610	75.698	97.49	500	PASS

U-NII-3

Network Standards	Carrier frequency (MHz)	99% bandwidth (MHz)	Minimum 6 dB bandwidth (MHz)	Limit (kHz)	Conclusion
802.11a	5745	17.941	17.56	500	PASS
	5785	18.036	17.58	500	PASS
	5825	17.889	17.54	500	PASS
802.11n HT20	5745	18.654	17.04	500	PASS
	5785	18.628	16.92	500	PASS
	5825	18.509	17.30	500	PASS
802.11n HT40	5755	36.320	36.27	500	PASS
	5795	36.328	35.67	500	PASS
802.11ac HT20	5745	17.925	17.09	500	PASS
	5785	17.914	17.55	500	PASS
	5825	17.948	17.56	500	PASS
802.11ac HT40	5755	36.316	36.02	500	PASS
	5795	36.352	36.04	500	PASS
802.11ac HT80	5775	75.637	75.34	500	PASS

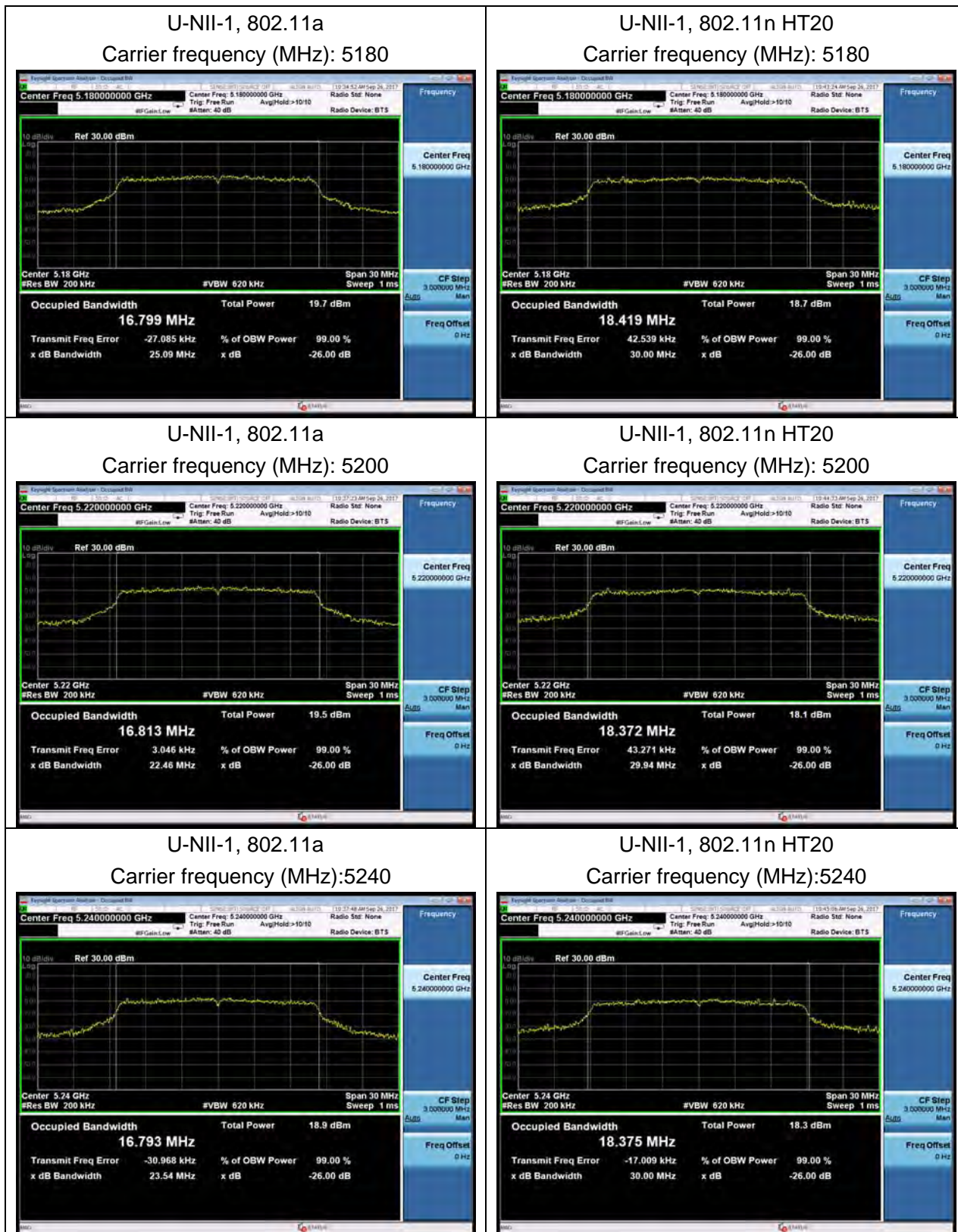

U-NII-1, 802.11n HT40
Carrier frequency (MHz): 5190



U-NII-1, 802.11ac HT20
Carrier frequency (MHz): 5180



U-NII-1, 802.11n HT40
Carrier frequency (MHz): 5230

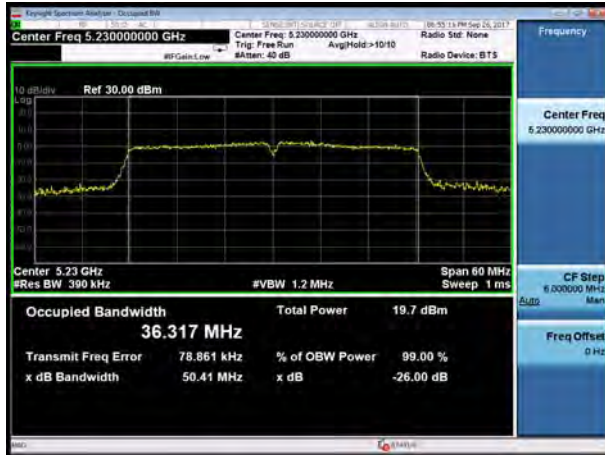

U-NII-1, 802.11ac HT20
Carrier frequency (MHz): 5200

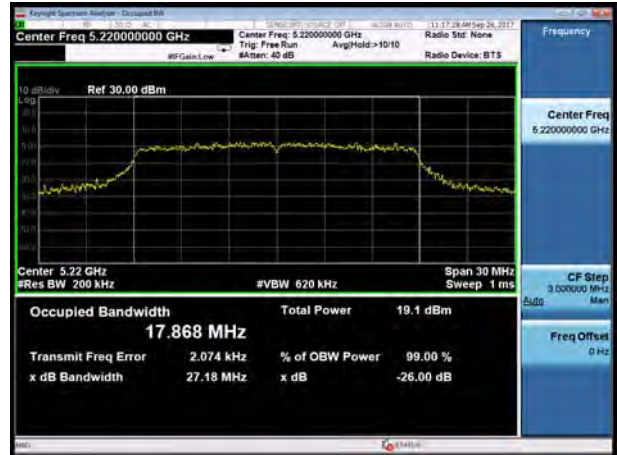

U-NII-1, 802.11ac HT20
Carrier frequency (MHz): 5240



U-NII-1, 802.11ac HT40
Carrier frequency (MHz): 5190

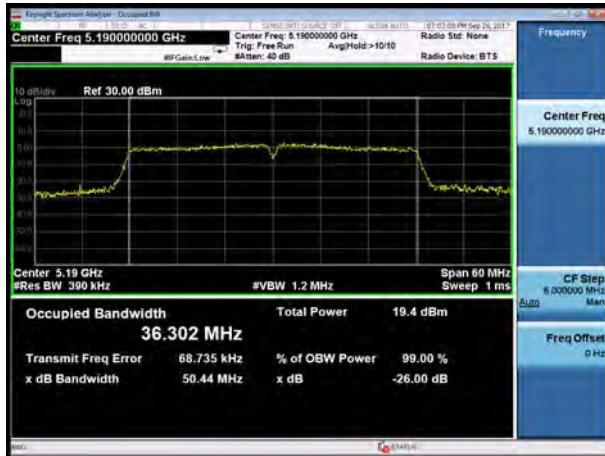

U-NII-1, 802.11ac HT80
Carrier frequency (MHz): 5210



U-NII-1, 802.11ac HT40
Carrier frequency (MHz): 5230



U-NII-2A, 802.11a
Carrier frequency (MHz): 5260



U-NII-2A, 802.11n HT20
Carrier frequency (MHz): 5260



U-NII-2A, 802.11a
Carrier frequency (MHz): 5300



U-NII-2A, 802.11n HT20
Carrier frequency (MHz): 5300



U-NII-2A, 802.11a
Carrier frequency (MHz): 5320



U-NII-2A, 802.11n HT20
Carrier frequency (MHz): 5320



U-NII-2A, 802.11n HT40
Carrier frequency (MHz): 5270

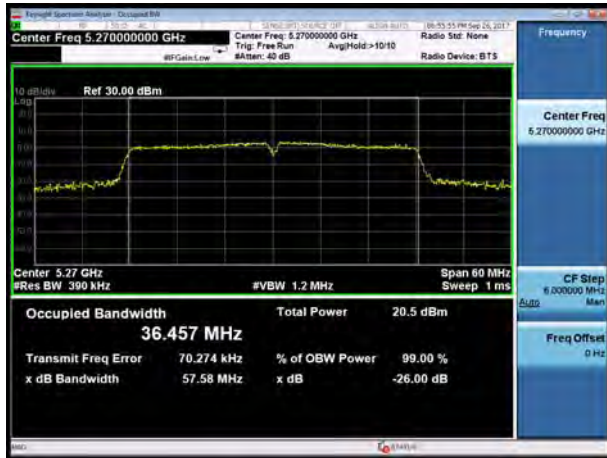

U-NII-2A, 802.11ac HT20
Carrier frequency (MHz): 5260



U-NII-2A, 802.11n HT40
Carrier frequency (MHz): 5310



U-NII-2A, 802.11ac HT20
Carrier frequency (MHz): 5300



U-NII-2A, 802.11ac HT20
Carrier frequency (MHz): 5320

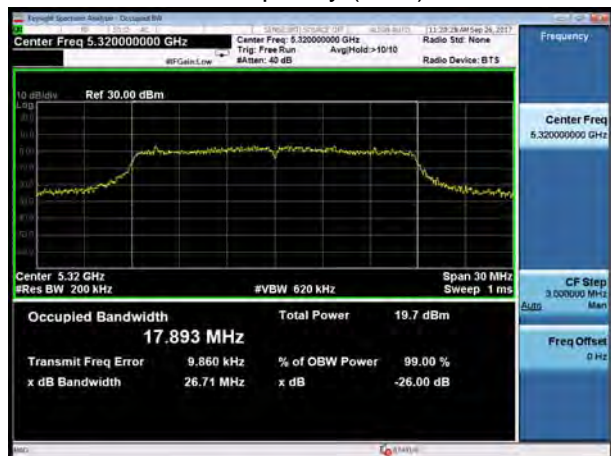



U-NII-2A, 802.11ac HT40
Carrier frequency (MHz): 5270



U-NII-2A, 802.11ac HT80
Carrier frequency (MHz): 5290



U-NII-2A, 802.11ac HT40
Carrier frequency (MHz): 5310



U-NII-2C, 802.11a
Carrier frequency (MHz): 5500



U-NII-2C, 802.11n HT20
Carrier frequency (MHz): 5500



U-NII-2C, 802.11a
Carrier frequency (MHz): 5580



U-NII-2C, 802.11n HT20
Carrier frequency (MHz): 5580



U-NII-2C, 802.11a
Carrier frequency (MHz): 5700



U-NII-2C, 802.11n HT20
Carrier frequency (MHz): 5700



U-NII-2C, 802.11n HT40
Carrier frequency (MHz): 5510

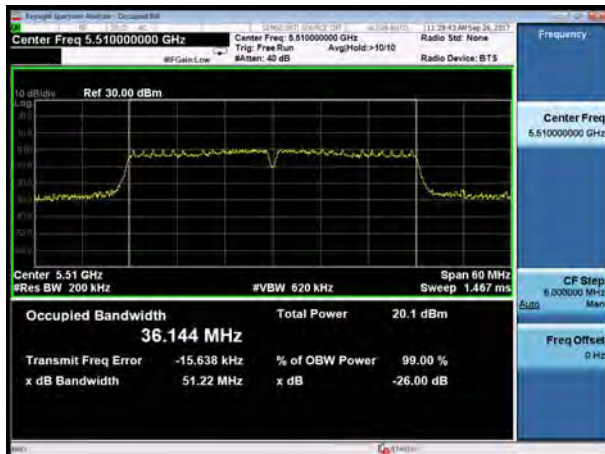

U-NII-2C, 802.11ac HT20
Carrier frequency (MHz): 5500



U-NII-2C, 802.11n HT40
Carrier frequency (MHz): 5670



U-NII-2C, 802.11ac HT20
Carrier frequency (MHz): 5580



U-NII-2C, 802.11ac HT20
Carrier frequency (MHz): 5700



U-NII-2C, 802.11ac HT40
Carrier frequency (MHz): 5510



U-NII-2C, 802.11ac HT80
Carrier frequency (MHz): 5530



U-NII-2C, 802.11ac HT40
Carrier frequency (MHz): 5550



U-NII-2C, 802.11ac HT80
Carrier frequency (MHz): 5610





Minimum 6 dB bandwidth

U-NII-3, 802.11a

Carrier frequency (MHz): 5745

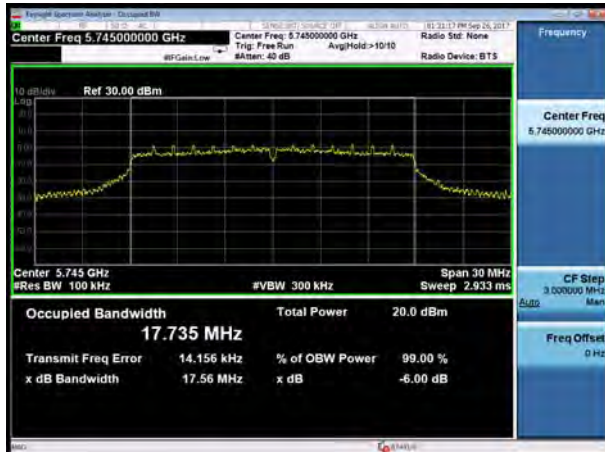

U-NII-3, 802.11n HT20

Carrier frequency (MHz): 5745



U-NII-3, 802.11a

Carrier frequency (MHz): 5785



U-NII-3, 802.11n HT20

Carrier frequency (MHz): 5785



U-NII-3, 802.11a

Carrier frequency (MHz): 5825



U-NII-3, 802.11n HT20

Carrier frequency (MHz): 5825

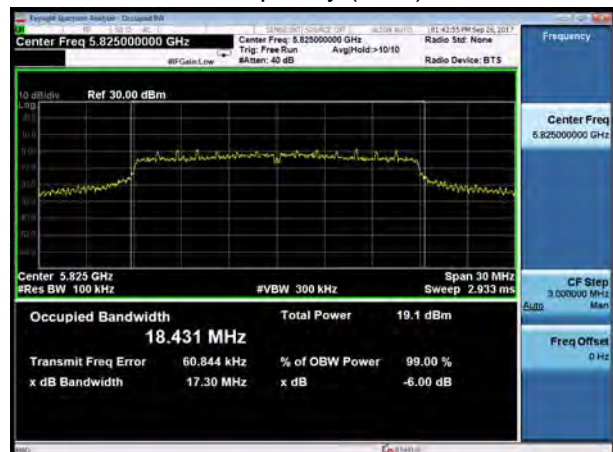

U-NII-3, 802.11n HT40
Carrier frequency (MHz): 5755



U-NII-3, 802.11ac HT20
Carrier frequency (MHz): 5745

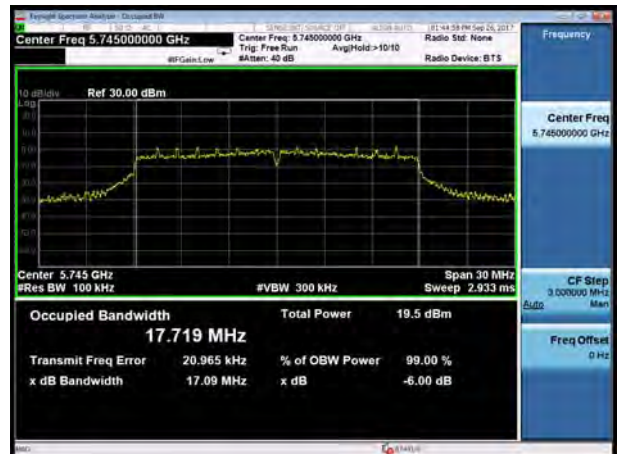

U-NII-3, 802.11n HT40
Carrier frequency (MHz): 5795

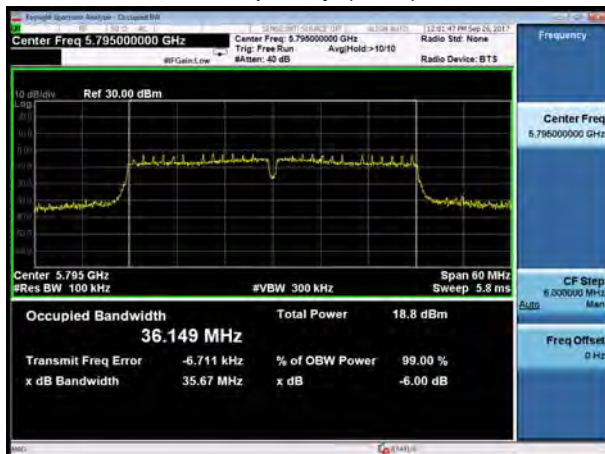

U-NII-3, 802.11ac HT20
Carrier frequency (MHz): 5785



U-NII-3, 802.11ac HT40
Carrier frequency (MHz): 5755



U-NII-3, 802.11ac HT20
Carrier frequency (MHz): 5825





U-NII-3, 802.11ac HT40
Carrier frequency (MHz): 5795



U-NII-3, 802.11ac HT80
Carrier frequency (MHz): 5775

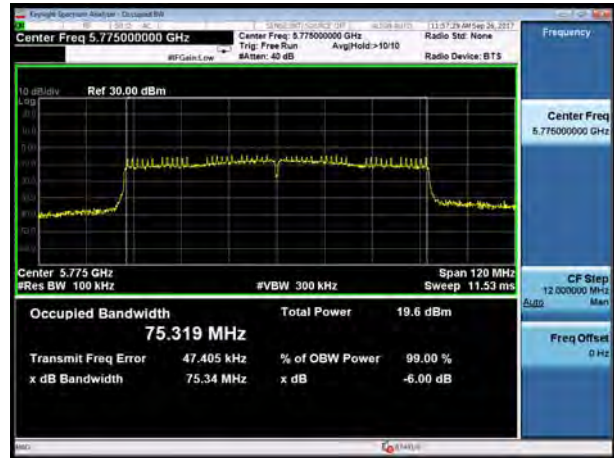



99% bandwidth

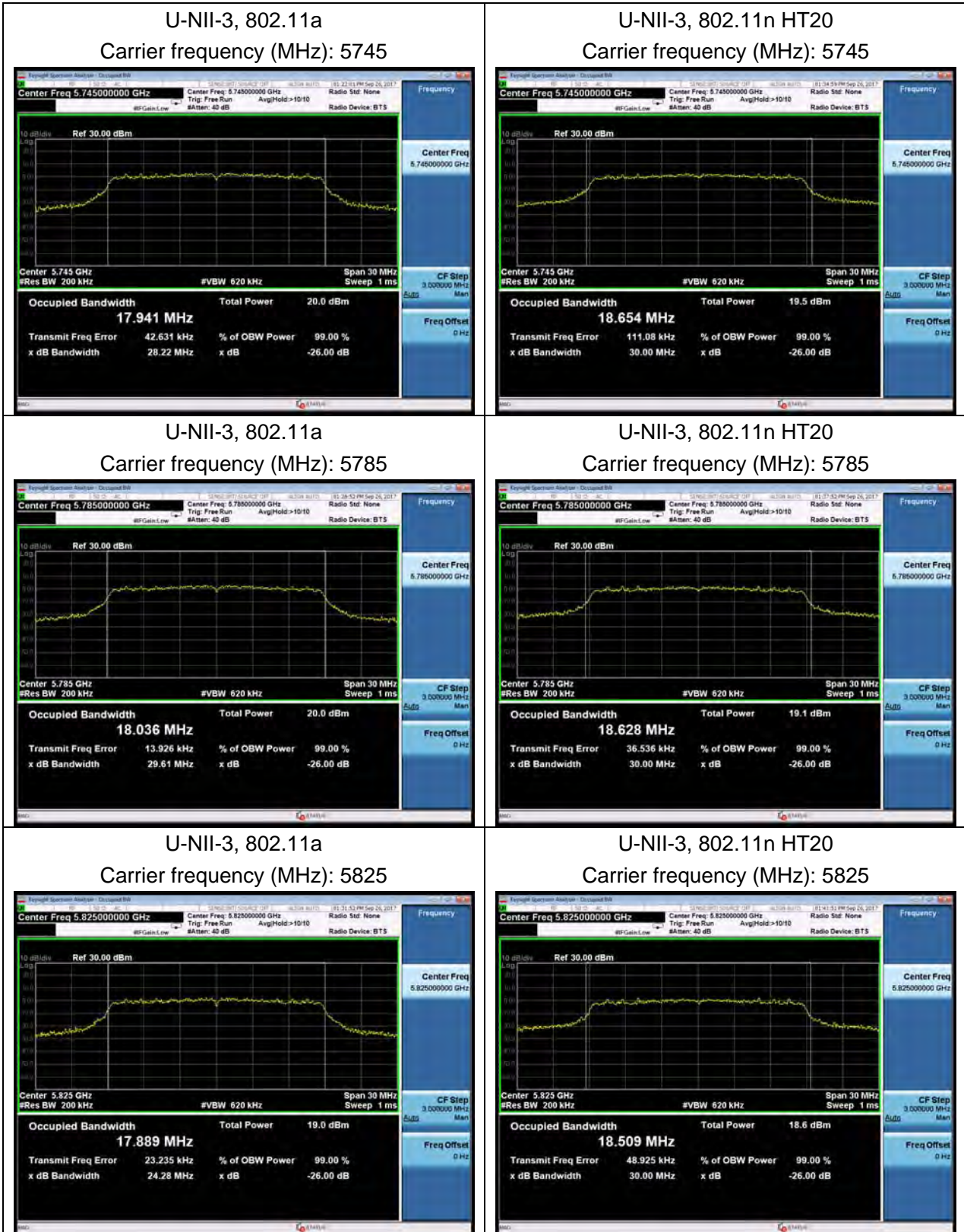

U-NII-3, 802.11n HT40
Carrier frequency (MHz): 5755

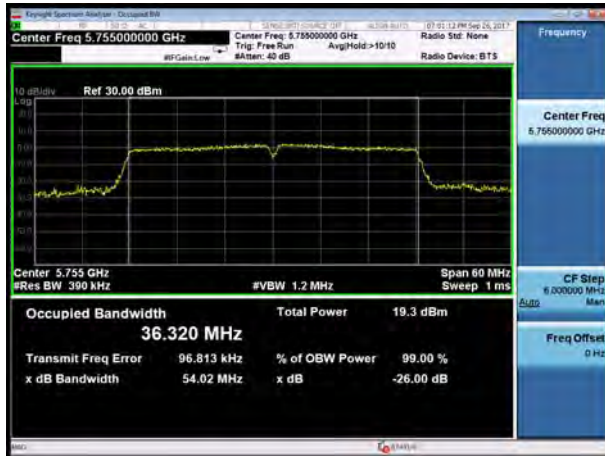

U-NII-3, 802.11ac HT20
Carrier frequency (MHz): 5745

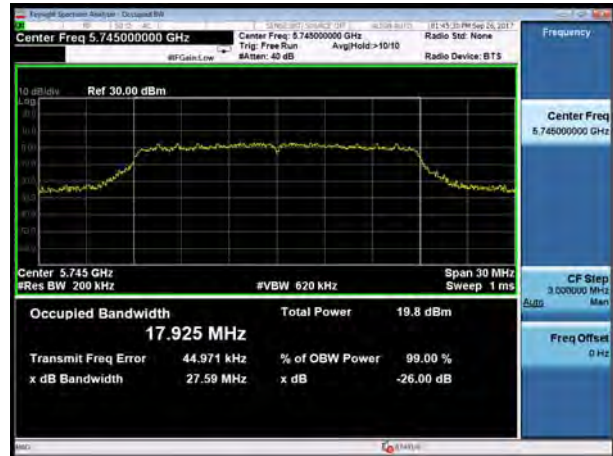

U-NII-3, 802.11n HT40
Carrier frequency (MHz): 5795



U-NII-3, 802.11ac HT20
Carrier frequency (MHz): 5785



U-NII-3, 802.11ac HT40
Carrier frequency (MHz): 5755



U-NII-3, 802.11ac HT20
Carrier frequency (MHz): 5825

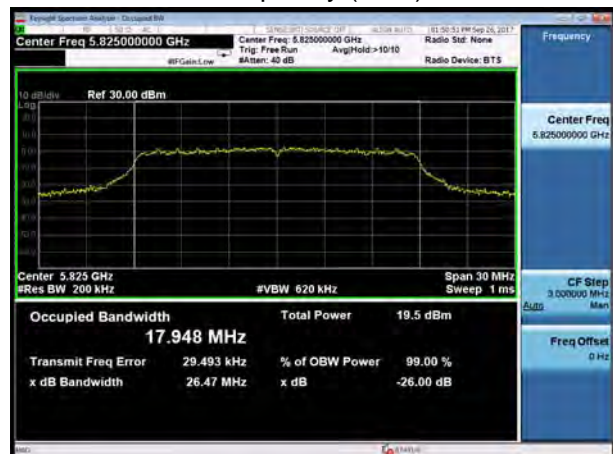



U-NII-3, 802.11ac HT40
Carrier frequency (MHz): 5795

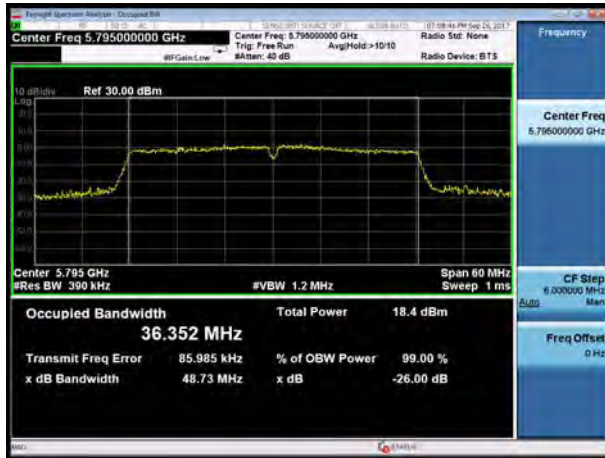

U-NII-3, 802.11ac HT80
Carrier frequency (MHz): 5775

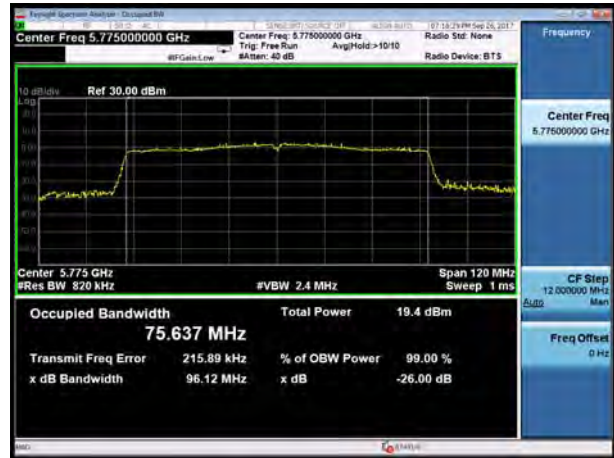

5.2. Average Power Output –Conducted

Ambient condition

Temperature	Relative humidity	Pressure
23°C ~25°C	45%~50%	101.5kPa

Methods of Measurement

During the process of the testing, The EUT was connected to spectrum analyzer through an external attenuator and a known loss cable. The EUT is max power transmission with proper modulation. We use Maximum average Conducted Output Power Level Method in KDB789033 for this test

Test Setup

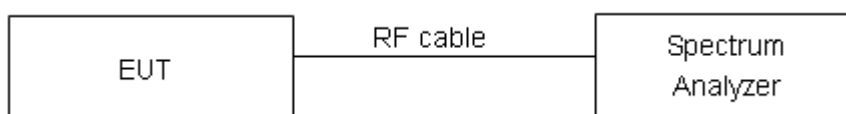

Limits

Rule FCC Part 15.407(a)(1)(2)(3)

For client devices in the 5.15-5.25 GHz band, the maximum conducted output power over the frequency band of operation shall not exceed 250 mW provided the maximum antenna gain does not exceed 6 dBi. In addition, the maximum power spectral density shall not exceed 11 dBm in any 1 megahertz band. If transmitting antennas of directional gain greater than 6 dBi are used, both the maximum conducted output power and the maximum power spectral density shall be reduced by the amount in dB that the directional gain of the antenna exceeds 6 dBi.

For the 5.25-5.35 GHz and 5.47-5.725 GHz bands, the maximum conducted output power over the frequency bands of operation shall not exceed the lesser of 250 mW or 11 dBm + 10 log B, where B is the 26 dB emission bandwidth in megahertz. In addition, the maximum power spectral density shall not exceed 11 dBm in any 1 megahertz band. If transmitting antennas of directional gain greater than 6 dBi are used, both the maximum conducted output power and the maximum power spectral density shall be reduced by the amount in dB that the directional gain of the antenna exceeds 6 dBi.

For the band 5.725-5.85 GHz, the maximum conducted output power over the frequency band of operation shall not exceed 1 W. In addition, the maximum power spectral density shall not exceed 30 dBm in any 500-kHz band. If transmitting antennas of directional gain greater than 6 dBi are used, both the maximum conducted output power and the maximum power spectral density shall be reduced by the amount in dB that the directional gain of the antenna exceeds 6 dBi.

Measurement Uncertainty

The assessed measurement uncertainty to ensure 95% confidence level for the normal distribution is with the coverage factor $k = 2$, $U = 0.44$ dB.



Test Results

Network Standards		Channel/Frequency (MHz)	B=26 dB bandwidth (MHz)	Limit 11 dBm + 10 log B (dBm)	Final Limit(dBm)
U-NII-2A	802.11a	52/5260	25.22	25.02>24	24
		60/5300	28.12	25.49>24	24
		64/5320	28.73	25.58>24	24
	802.11n HT20	52/5260	30.00	25.77>24	24
		60/5300	30.00	25.77>24	24
		64/5320	30.00	25.77>24	24
	802.11n HT40	54/5270	57.58	28.60>24	24
		62/5310	55.57	28.45>24	24
	802.11ac HT20	52/5260	27.94	25.46>24	24
		60/5300	26.69	25.26>24	24
		64/5320	26.71	25.27>24	24
	802.11ac HT40	54/5270	54.15	28.34>24	24
62/5310		59.50	28.75>24	24	
802.11ac HT80	58/5290	108.30	31.35>24	24	
U-NII-2C	802.11a	100/5500	24.61	24.91>24	24
		116/5580	26.70	25.27>24	24
		140/5700	22.98	24.61>24	24
	802.11n HT20	100/5500	30.00	25.77>24	24
		116/5580	29.86	25.75>24	24
		140/5700	29.98	25.77>24	24
	802.11n HT40	102/5510	51.22	28.09>24	24
		134/5670	46.85	27.71>24	24
	802.11ac HT20	100/5500	26.08	25.16>24	24
		116/5580	24.08	24.82>24	24
		140/5700	26.67	25.26>24	24
	802.11ac HT40	102/5510	42.67	27.30>24	24
		134/5670	50.11	28.00>24	24
	802.11ac HT80	106/5530	95.39	30.80>24	24
		122/5610	97.49	30.89>24	24
Note: 250mW=24dBm					

**Test results**

Note: Output Power=Read Value+Duty cycle correction factor

U-NII-1

Network Standards	Channel/ Frequency (MHz)	Output Power (dBm)	Limit (dBm)	Conclusion
802.11a	36/5180	14.33	24	PASS
	40/5200	14.19	24	PASS
	48/5240	14.16	24	PASS
802.11n HT20	36/5180	13.73	24	PASS
	40/5200	13.63	24	PASS
	48/5240	13.54	24	PASS
802.11n HT40	38/5190	13.79	24	PASS
	46/5230	13.78	24	PASS
802.11ac HT20	36/5180	14.32	24	PASS
	40/5200	14.22	24	PASS
	48/5240	14.17	24	PASS
802.11ac HT40	38/5190	13.71	24	PASS
	46/5230	13.76	24	PASS
802.11ac HT80	42/5210	13.57	24	PASS

U-NII-2A

Network Standards	Channel/ Frequency (MHz)	Output Power (dBm)	Limit (dBm)	Conclusion
802.11a	52/5260	14.94	24	PASS
	60/5300	15.20	24	PASS
	64/5320	15.33	24	PASS
802.11n HT20	52/5260	14.38	24	PASS
	60/5300	14.59	24	PASS
	64/5320	14.64	24	PASS
802.11n HT40	54/5270	14.62	24	PASS
	62/5310	14.76	24	PASS
802.11ac HT20	52/5260	14.95	24	PASS
	60/5300	15.01	24	PASS
	64/5320	15.34	24	PASS
802.11ac HT40	54/5270	14.57	24	PASS
	62/5310	14.95	24	PASS
802.11ac HT80	58/5290	14.75	24	PASS

U-NII-2C

Network Standards	Channel/Frequency (MHz)	Output Power (dBm)	Limit (dBm)	Conclusion
802.11a	100/5500	15.11	24	PASS
	116/5580	15.30	24	PASS
	140/5700	14.17	24	PASS
802.11n HT20	100/5500	14.53	24	PASS
	116/5580	14.75	24	PASS
	140/5700	13.15	24	PASS
802.11n HT40	102/5510	14.44	24	PASS
	134/5670	13.97	24	PASS
802.11ac HT20	100/5500	15.13	24	PASS
	116/5580	15.24	24	PASS
	140/5700	14.20	24	PASS
802.11ac HT40	102/5510	14.69	24	PASS
	134/5670	14.18	24	PASS
802.11ac HT80	106/5530	14.43	24	PASS
	122/5610	14.53	24	PASS

U-NII-3

Network Standards	Channel/Frequency (MHz)	Output Power (dBm)	Limit (dBm)	Conclusion
802.11a	149/5745	14.03	30	PASS
	157/5785	13.59	30	PASS
	165/5825	13.33	30	PASS
802.11n HT20	149/5745	13.32	30	PASS
	157/5785	13.88	30	PASS
	165/5825	12.76	30	PASS
802.11n HT40	151/5755	13.28	30	PASS
	159/5795	13.04	30	PASS
802.11ac HT20	149/5745	13.92	30	PASS
	157/5785	13.47	30	PASS
	165/5825	13.29	30	PASS
802.11ac HT40	151/5755	13.39	30	PASS
	159/5795	13.01	30	PASS
802.11ac HT80	155/5775	13.14	30	PASS

5.3. Frequency Stability

Ambient condition

Temperature	Relative humidity	Pressure
23°C ~25°C	45%~50%	101.5kPa

Method of Measurement

1. Frequency stability with respect to ambient temperature

- a) Supply the EUT with a nominal ac voltage or install a new or fully charged battery in the EUT. If possible, a dummy load shall be connected to the EUT because an antenna near the metallic walls of an environmental test chamber could affect the output frequency of the EUT. If the EUT is equipped with a permanently attached, adjustable-length antenna, then the EUT shall be placed in the center of the chamber with the antenna adjusted to the shortest length possible. Turn ON the EUT and tune it to one of the number of frequencies shown in 5.6.
- b) Couple the unlicensed wireless device output to the measuring instrument by connecting an antenna to the measuring instrument with a suitable length of coaxial cable and placing the measuring antenna near the EUT (e.g., 15 cm away), or by connecting a dummy load to the measuring instrument, through an attenuator if necessary.
- c) Adjust the location of the measurement antenna and the controls on the measurement instrument to obtain a suitable signal level (i.e., a level that will not overload the measurement instrument but is strong enough to allow measurement of the operating or fundamental frequency of the EUT).
- d) Turn the EUT OFF and place it inside the environmental temperature chamber. For devices that have oscillator heaters, energize only the heater circuit.
- e) Set the temperature control on the chamber to the highest specified in the regulatory requirements for the type of device and allow the oscillator heater and the chamber temperature to stabilize.
- f) While maintaining a constant temperature inside the environmental chamber, turn the EUT ON and record the operating frequency at startup, and at 2 minutes, 5 minutes, and 10 minutes after the EUT is energized. Four measurements in total are made.
- g) Measure the frequency at each of frequencies specified in 5.6.
- h) Switch OFF the EUT but do not switch OFF the oscillator heater.
- i) Lower the chamber temperature by not more than 10 C, and allow the temperature inside the chamber to stabilize.
- j) Repeat step f) through step i) down to the lowest specified temperature.

2. Frequency stability when varying supply voltage

Unless otherwise specified, these tests shall be made at ambient room temperature (+15 C to +25

C). An antenna shall be connected to the antenna output terminals of the EUT if possible. If the EUT is equipped with or uses an adjustable-length antenna, then it shall be fully extended.

- a) Supply the EUT with nominal voltage or install a new or fully charged battery in the EUT. Turn ON the EUT and couple its output to a frequency counter or other frequency-measuring instrument.



- b) Tune the EUT to one of the number of frequencies required in 5.6. Adjust the location of the measurement antenna and the controls on the measurement instrument to obtain a suitable signal level (i.e., a level that will not overload the measurement instrument but is strong enough to allow measurement of the operating or fundamental frequency of the EUT).
- c) Measure the frequency at each of the frequencies specified in 5.6.
- d) Repeat the above procedure at 85% and 115% of the nominal supply voltage.

Limit

Manufacturers of U-NII devices are responsible for ensuring frequency stability such that an emission is maintained within the band of operation under all conditions of normal operation as specified in the users manual.

Measurement Uncertainty

The assessed measurement uncertainty to ensure 95% confidence level for the normal distribution is with the coverage factor $k = 2$, $U = 936\text{Hz}$

**Test Results**

Voltage (V)	Temperature (°C)	U-NII-1 Test Results			
		5200MHz			
		1min	2min	5min	10min
5.00	-20	5200.004180	5199.998706	5199.998459	5199.996487
5.00	-10	5199.997235	5199.990304	5199.996709	5199.989195
5.00	0	5199.995143	5199.983339	5199.994906	5199.979405
5.00	10	5199.989172	5199.974780	5199.991329	5199.977669
5.00	20	5199.983976	5199.974411	5199.983626	5199.972356
5.00	30	5199.978437	5199.972565	5199.983079	5199.969500
5.00	40	5199.977762	5199.963160	5199.982536	5199.960325
5.00	50	5199.972845	5199.961565	5199.982133	5199.953994
4.75	20	5199.969891	5199.952306	5199.973750	5199.948580
5.25	20	5199.967572	5199.944281	5199.965574	5199.938979
MHz		-0.032428	-0.055719	-0.034426	-0.061021
PPM		-6.236161	-10.715218	-6.620400	-11.734718

Voltage (V)	Temperature (°C)	U-NII-2A Test Results			
		5300MHz			
		1min	2min	5min	10min
5.00	-20	5300.009747	5299.999793	5299.998730	5299.995291
5.00	-10	5300.001103	5299.996482	5299.997749	5299.988601
5.00	0	5299.997284	5299.995073	5299.990854	5299.978610
5.00	10	5299.997151	5299.988140	5299.987648	5299.974892
5.00	20	5299.991207	5299.982820	5299.981766	5299.968853
5.00	30	5299.986040	5299.982817	5299.972881	5299.962431
5.00	40	5299.980314	5299.975523	5299.972459	5299.956765
5.00	50	5299.978669	5299.973447	5299.963752	5299.955407
4.75	20	5299.975419	5299.967902	5299.960366	5299.950643
5.25	20	5299.966847	5299.965104	5299.959604	5299.949418
MHz		-0.033153	-0.034896	-0.040396	-0.050582
PPM		-6.255341	-6.584219	-7.621914	-9.543681



Voltage (V)	Temperature (°C)	U-NII-2C Test Results			
		5580MHz			
		1min	2min	5min	10min
5.00	-20	5579.991567	5579.986591	5579.981913	5579.975454
5.00	-10	5579.984512	5579.979536	5579.977556	5579.969495
5.00	0	5579.983045	5579.974742	5579.976330	5579.963365
5.00	10	5579.980210	5579.966835	5579.971417	5579.954712
5.00	20	5579.976439	5579.962396	5579.964445	5579.947961
5.00	30	5579.970596	5579.958460	5579.959864	5579.938663
5.00	40	5579.964652	5579.957692	5579.950200	5579.932692
5.00	50	5579.956040	5579.956682	5579.942258	5579.927723
4.75	20	5579.950438	5579.952881	5579.939924	5579.919825
5.25	20	5579.946234	5579.947668	5579.936790	5579.911976
MHz		-0.053766	-0.052332	-0.063210	-0.088024
PPM		-9.635420	-9.378459	-11.327931	-15.774958

Voltage (V)	Temperature (°C)	U-NII-3 Test Results			
		5785MHz			
		1min	2min	5min	10min
5.00	-20	5785.000827	5784.997343	5784.994010	5784.992403
5.00	-10	5784.992566	5784.990218	5784.987134	5784.985886
5.00	0	5784.983063	5784.981410	5784.985251	5784.981716
5.00	10	5784.978057	5784.974405	5784.982567	5784.973989
5.00	20	5784.972050	5784.967990	5784.981451	5784.967529
5.00	30	5784.972019	5784.963756	5784.978326	5784.963336
5.00	40	5784.964032	5784.959066	5784.978113	5784.957690
5.00	50	5784.956681	5784.953077	5784.975997	5784.954923
4.75	20	5784.954141	5784.951913	5784.969827	5784.947006
5.25	20	5784.944401	5784.945756	5784.968595	5784.938891
MHz		-0.055599	-0.054244	-0.031405	-0.061109
PPM		-9.610811	-9.376643	-5.428775	-10.563302

5.4. Power Spectral Density

Ambient condition

Temperature	Relative humidity	Pressure
23°C ~25°C	45%~50%	101.5kPa

Method of Measurement

The EUT was connected to the spectrum analyzer through an external attenuator (20dB) and a known loss cable.

Set RBW = 500 kHz, VBW =1.5MHz for the band 5.725-5.85 GHz

Set RBW = 1 MHz, VBW =3MHz for the band 5.150-5.250 GHz

The conducted PSD is measured at each antenna port. The measured results at the various antenna ports are then summed mathematically.

Test setup

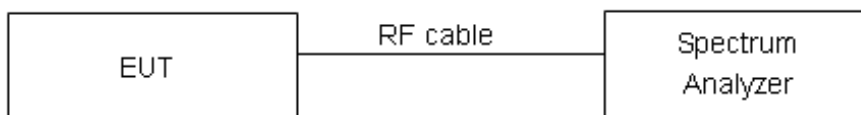

Limits

Rule FCC Part 15.407(a)(1)/ Part 15.407(a)(2) / Part 15.407(a)(3)

For an indoor access point operating in the band 5.15-5.25 GHz, the maximum power spectral density shall not exceed 17 dBm in any 1 megahertz band. If transmitting antennas of directional gain greater than 6 dBi are used, both the maximum conducted output power and the maximum power spectral density shall be reduced by the amount in dB that the directional gain of the antenna exceeds 6 dBi.

For the 5.25-5.35 GHz and 5.47-5.725 GHz bands, the maximum power spectral density shall not exceed 11 dBm in any 1 megahertz band. If transmitting antennas of directional gain greater than 6 dBi are used, both the maximum conducted output power and the maximum power spectral density shall be reduced by the amount in dB that the directional gain of the antenna exceeds 6 dBi.

For the band 5.725-5.85 GHz, the maximum power spectral density shall not exceed 30 dBm in any 500-kHz band. If transmitting antennas of directional gain greater than 6 dBi are used, both the maximum conducted output power and the maximum power spectral density shall be reduced by the amount in dB that the directional gain of the antenna exceeds 6 dBi.

Frequency Bands/MHz	Limits
5150-5250	17dBm/MHz
5.25-5.35 GHz and 5.47-5.725 GHz	11dBm/MHz
5725-5850	30dBm/500kHz



Measurement Uncertainty

The assessed measurement uncertainty to ensure 95% confidence level for the normal distribution is with the coverage factor $k = 2$, $U = 0.75\text{dB}$.

**Test Results:**

Note: Power Spectral Density =Read Value+Duty cycle correction factor

U-NII-1

Network Standards	Channel Number	Power Spectral Density (dBm /MHz)	Limit (dBm /MHz)	Conclusion
802.11a	36	4.076	17	PASS
	40	3.521	17	PASS
	48	3.684	17	PASS
802.11n HT20	36	2.960	17	PASS
	40	3.046	17	PASS
	48	3.130	17	PASS
802.11n HT40	38	-0.026	17	PASS
	46	0.350	17	PASS
802.11ac HT20	36	3.571	17	PASS
	40	3.844	17	PASS
	48	3.737	17	PASS
802.11ac HT40	38	0.202	17	PASS
	46	-0.344	17	PASS
802.11ac HT80	42	-3.011	17	PASS

U-NII-2A

Network Standards	Channel Number	Power Spectral Density (dBm /MHz)	Limit (dBm /MHz)	Conclusion
802.11a	52	4.190	11	PASS
	60	4.356	11	PASS
	64	4.766	11	PASS
802.11n HT20	52	3.633	11	PASS
	60	4.332	11	PASS
	64	4.242	11	PASS
802.11n HT40	54	1.371	11	PASS
	62	1.532	11	PASS
802.11ac HT20	52	4.690	11	PASS
	60	4.821	11	PASS
	64	5.120	11	PASS
802.11ac HT40	54	1.844	11	PASS
	62	1.891	11	PASS



802.11ac HT80	58	-1.894	11	PASS
---------------	----	--------	----	------

U-NII-2C

Network Standards	Channel Number	Power Spectral Density (dBm /MHz)	Limit (dBm /MHz)	Conclusion
802.11a	100	4.844	11	PASS
	116	4.513	11	PASS
	140	3.501	11	PASS
802.11n HT20	100	3.697	11	PASS
	116	4.423	11	PASS
	140	3.220	11	PASS
802.11n HT40	102	0.895	11	PASS
	110	1.267	11	PASS
	134	0.698	11	PASS
802.11ac HT20	100	4.942	11	PASS
	116	5.171	11	PASS
	140	3.704	11	PASS
802.11ac HT40	102	1.123	11	PASS
	110	1.587	11	PASS
	134	0.595	11	PASS
802.11ac HT80	106	-1.618	11	PASS
	122	-2.577	11	PASS

U-NII-3

Network Standards	Channel Number	Power Spectral Density (dBm/500kHz)	Limit (dBm/500kHz)	Conclusion
802.11a	149	0.282	30	PASS
	157	-0.495	30	PASS
	165	-1.299	30	PASS
802.11n HT20	149	-1.381	30	PASS
	157	-0.893	30	PASS
	165	-1.625	30	PASS
802.11n HT40	151	-3.041	30	PASS
	159	-3.865	30	PASS
802.11ac HT20	149	-0.98	30	PASS
	157	-0.837	30	PASS
	165	-1.210	30	PASS
802.11ac HT40	151	-2.89	30	PASS
	159	-3.275	30	PASS
802.11ac HT80	155	-6.255	30	PASS



U-NII-1, 802.11a, Channel No.: 36



U-NII-1, 802.11n HT20, Channel No.: 36

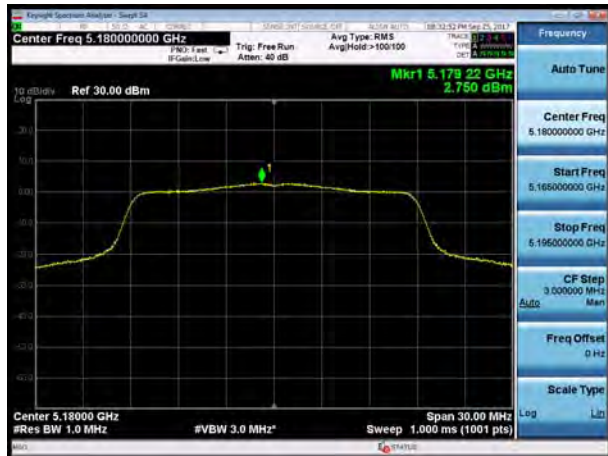

U-NII-1, 802.11a, Channel No.: 40



U-NII-1, 802.11n HT20, Channel No.: 40

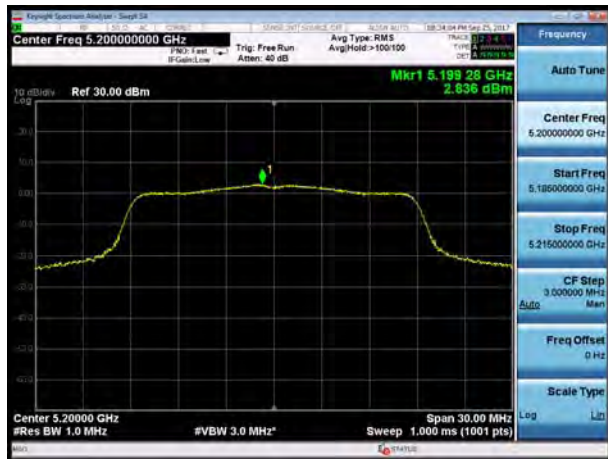

U-NII-1, 802.11a, Channel No.: 48



U-NII-1, 802.11n HT20, Channel No.: 48





U-NII-1, 802.11n HT40, Channel No.: 38



U-NII-1, 802.11ac HT20, Channel No.: 36

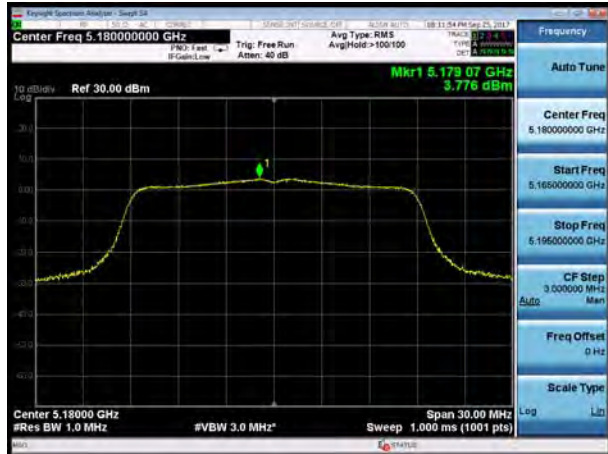

U-NII-1, 802.11n HT40, Channel No.: 46

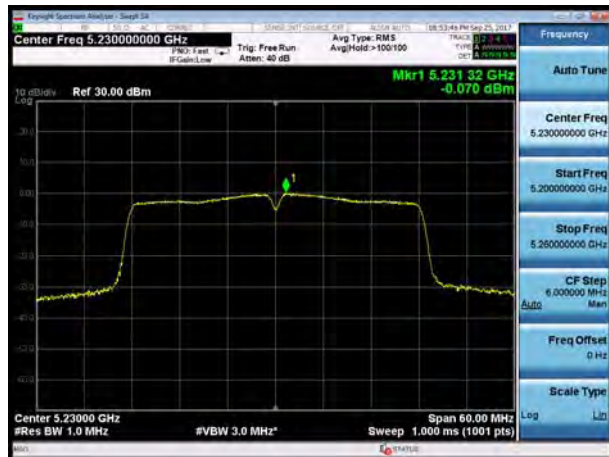

U-NII-1, 802.11ac HT20, Channel No.: 44

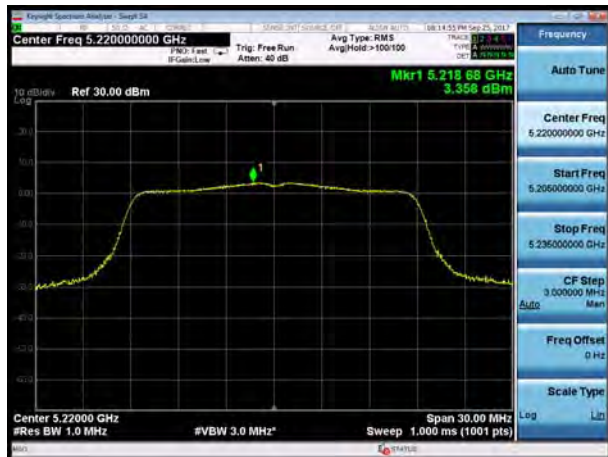

U-NII-1, 802.11ac HT40, Channel No.: 38

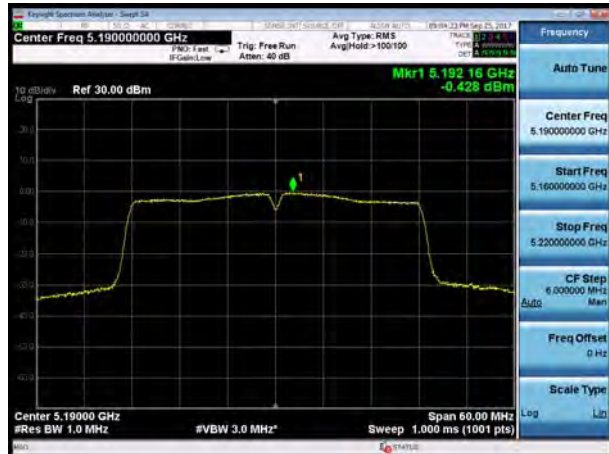

U-NII-1, 802.11ac HT20, Channel No.: 48





U-NII-1, 802.11ac HT40, Channel No.: 46



U-NII-1, 802.11ac HT80, Channel No.: 46



U-NII-2A, 802.11a, Channel No.: 52

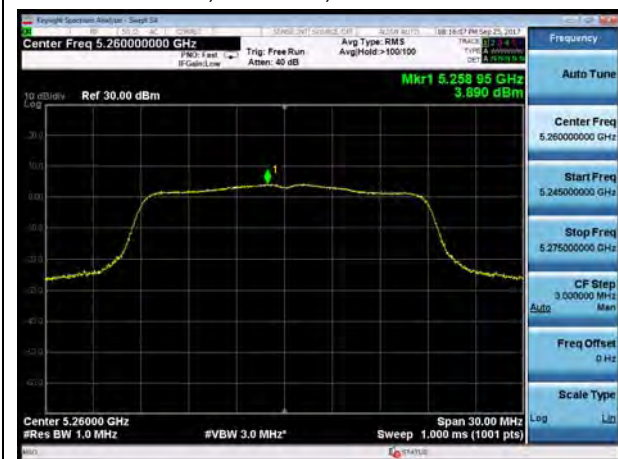

U-NII-2A, 802.11n HT20, Channel No.: 52

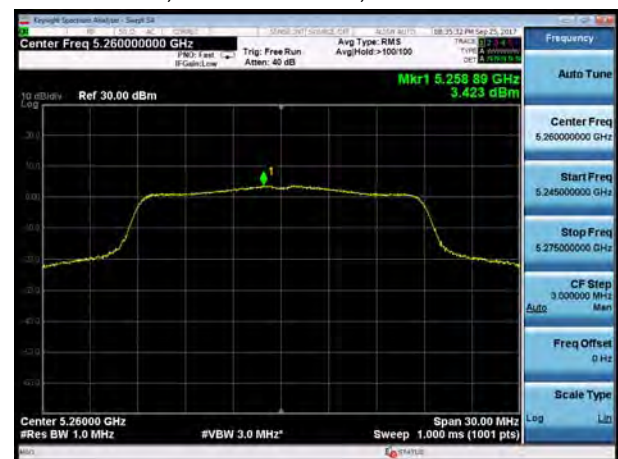

U-NII-2A, 802.11a, Channel No.: 60



U-NII-2A, 802.11n HT20, Channel No.: 60





U-NII-2A, 802.11a, Channel No.: 64

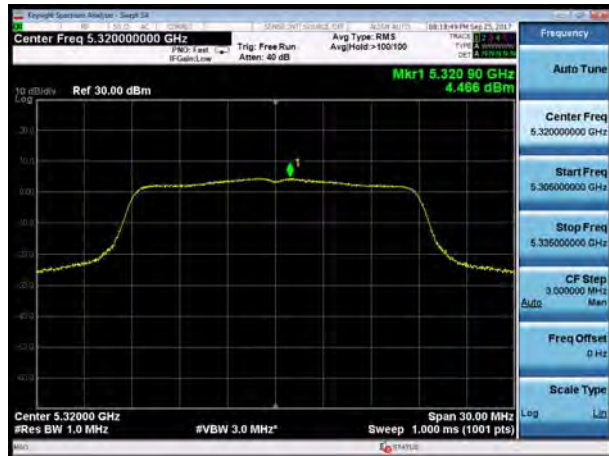

U-NII-2A, 802.11n HT20, Channel No.: 64

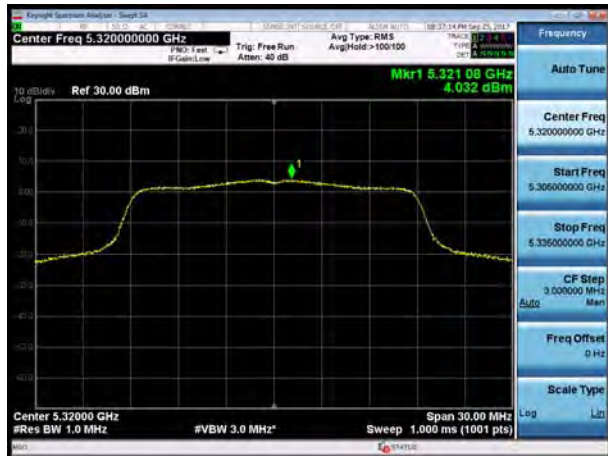

U-NII-2A, 802.11n HT40, Channel No.: 54



U-NII-2A, 802.11ac HT20, Channel No.:52



U-NII-2A, 802.11n HT40, Channel No.: 62



U-NII-2A, 802.11ac HT20, Channel No.: 60



U-NII-2A, 802.11ac HT40, Channel No.: 54



U-NII-2A, 802.11ac HT20, Channel No.: 64

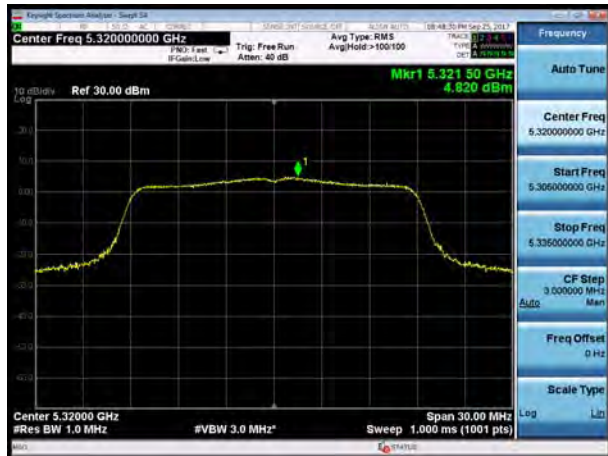

U-NII-2A, 802.11ac HT40, Channel No.: 62



U-NII-2A, 802.11ac HT80, Channel No.: 58





U-NII-2C, 802.11a, Channel No.: 100



U-NII-2C, 802.11n HT20, Channel No.: 100



U-NII-2C, 802.11a, Channel No.: 116

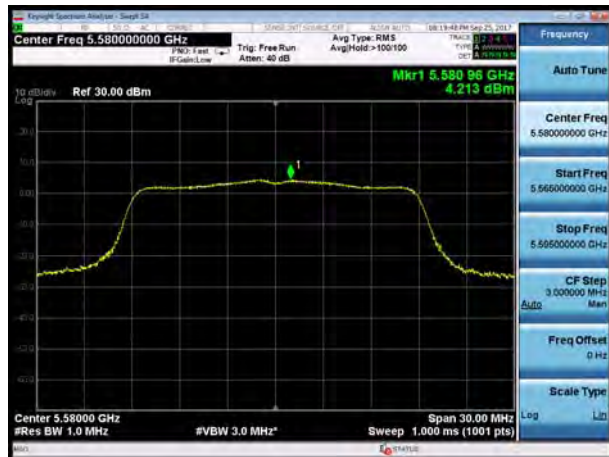

U-NII-2C, 802.11n HT20, Channel No.: 116



U-NII-2C, 802.11a, Channel No.: 140



U-NII-2C, 802.11n HT20, Channel No.: 140





U-NII-2C, 802.11n HT40, Channel No.: 102



U-NII-2C, 802.11ac HT20, Channel No.: 100



U-NII-2C, 802.11n HT40, Channel No.: 110

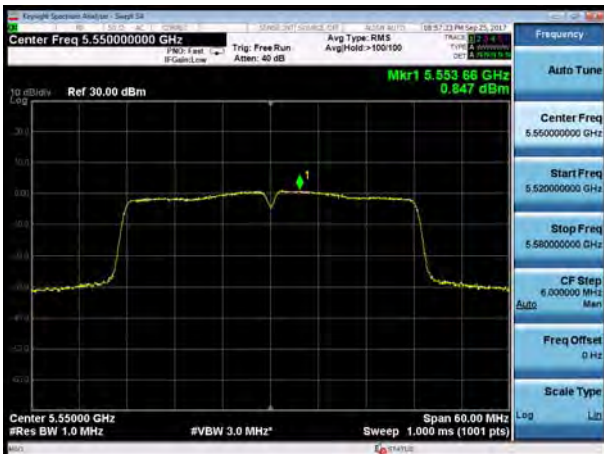

U-NII-2C, 802.11ac HT20, Channel No.: 116



U-NII-2C, 802.11n HT40, Channel No.: 134



U-NII-2C, 802.11ac HT20, Channel No.: 140





U-NII-2C, 802.11ac HT40, Channel No.: 102



U-NII-2C, 802.11ac HT80, Channel No.: 106



U-NII-2C, 802.11ac HT40, Channel No.: 110



U-NII-2C, 802.11ac HT80, Channel No.: 122



U-NII-2C, 802.11ac HT40, Channel No.: 134



U-NII-3, 802.11a, Channel No.: 149



U-NII-3, 802.11n HT20, Channel No.: 149



U-NII-3, 802.11a, Channel No.: 157



U-NII-3, 802.11n HT20, Channel No.: 157



U-NII-3, 802.11a, Channel No.: 165



U-NII-3, 802.11n HT20, Channel No.: 165





U-NII-3, 802.11n HT40, Channel No.: 151



U-NII-3, 802.11ac HT20, Channel No.: 149



U-NII-3, 802.11n HT40, Channel No.: 159

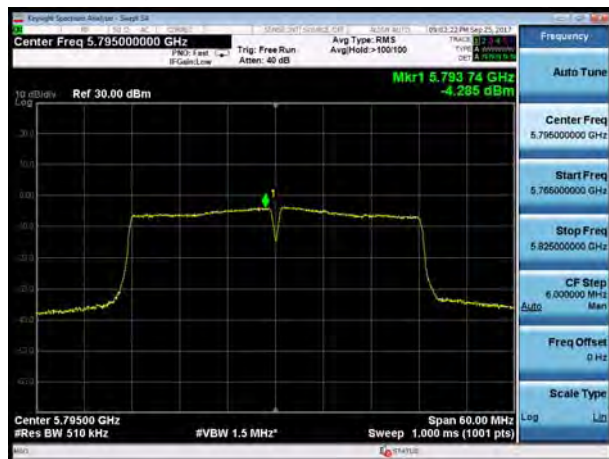

U-NII-3, 802.11ac HT20, Channel No.: 157

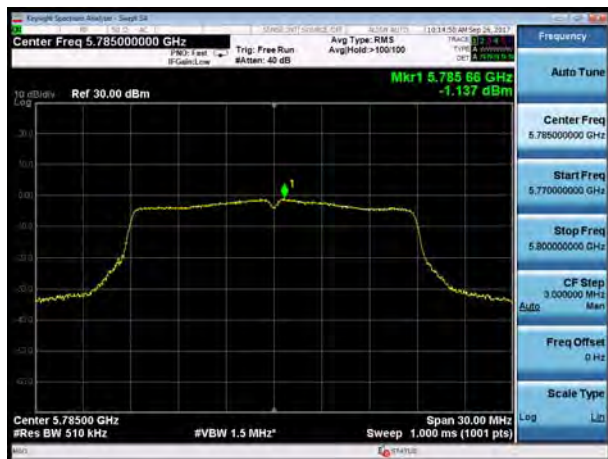

U-NII-3, 802.11ac HT40, Channel No.: 151



U-NII-3, 802.11ac HT20, Channel No.: 165



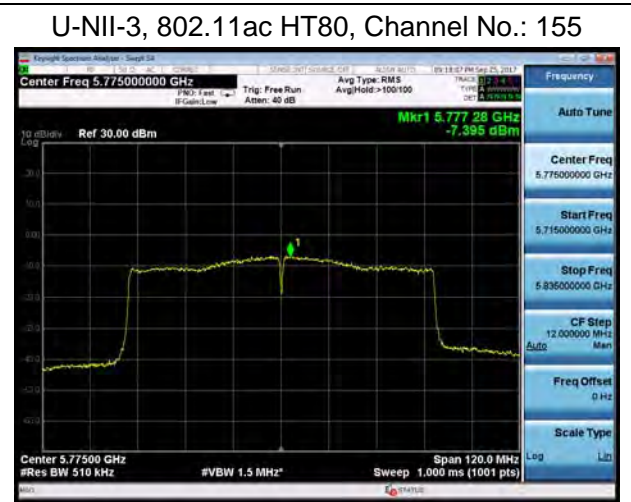
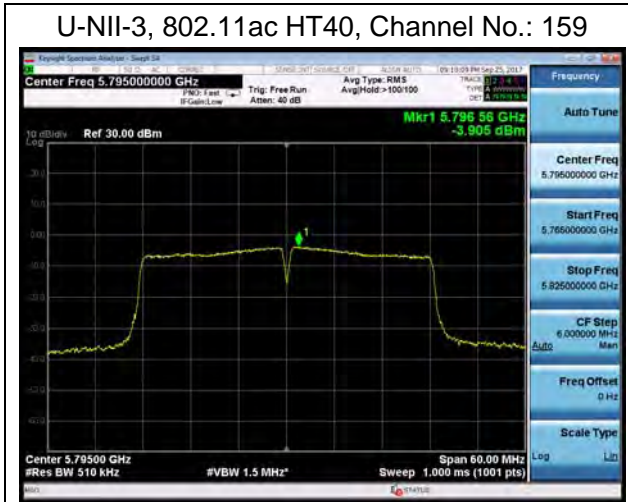

5.5. Unwanted Emission

Ambient condition

Temperature	Relative humidity	Pressure
23°C ~25°C	45%~50%	101.5kPa

Method of Measurement

The test set-up was made in accordance to the general provisions of ANSI C63.10-2013. The Equipment Under Test (EUT) was set up on a non-conductive table in the semi-anechoic chamber. The test was performed at the distance of 3 m between the EUT and the receiving antenna. The radiated emissions measurements were made in a typical installation configuration. Sweep the whole frequency band range from 9kHz to the 10th harmonic of the carrier, and the emissions less than 20 dB below the permissible value are reported.

During the test, the height of receive antenna shall be moved from 1 to 4 meters, and the antenna shall be performed under horizontal and vertical polarization. The turntable shall be rotated from 0 to 360 degrees for detecting the maximum of radiated spurious signal level. The measurements shall be repeated with orthogonal polarization of the test antenna. The data of cable loss and antenna factor has been calibrated in full testing frequency range before the testing.

Set the spectrum analyzer in the following:

Below 1GHz (detector: Peak and Quasi-Peak)

RBW=100kHz / VBW=300kHz / Sweep=AUTO

Above 1GHz (detector: Peak):

(a) PEAK: RBW=1MHz VBW=3MHz/ Sweep=AUTO

(b) AVERAGE: RBW=1MHz / VBW=3MHz / Sweep=AUTO

The radiated emission was measured in the following position: EUT stand-up position (Z axis), lie-down position (X, Y axis). The worst emission was found in stand-up position (Z axis) and the worst case was recorded.

The test is in transmitting mode.

9KHz~~~30MHz

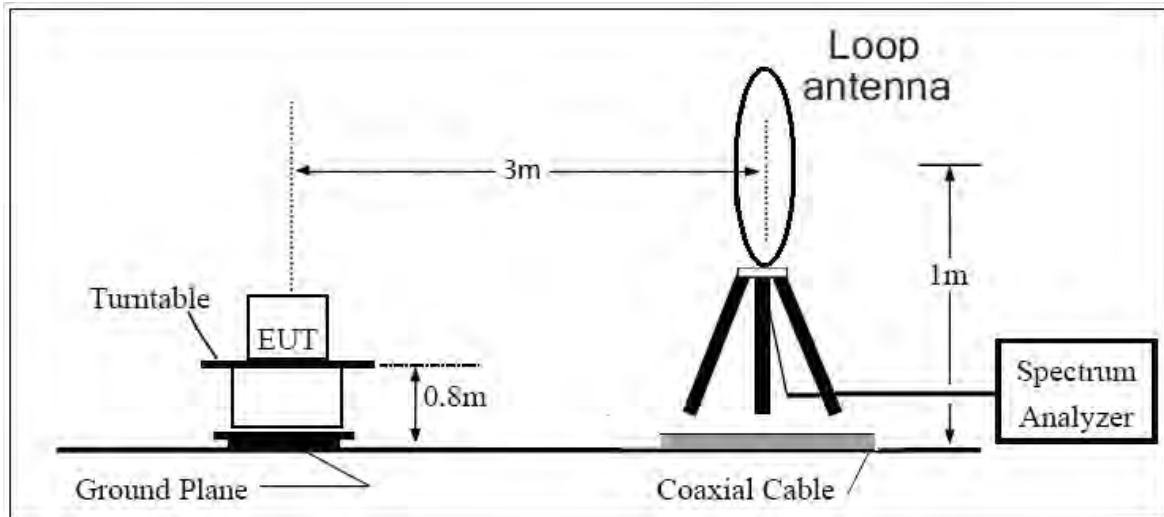

30MHz~~~ 1GHz

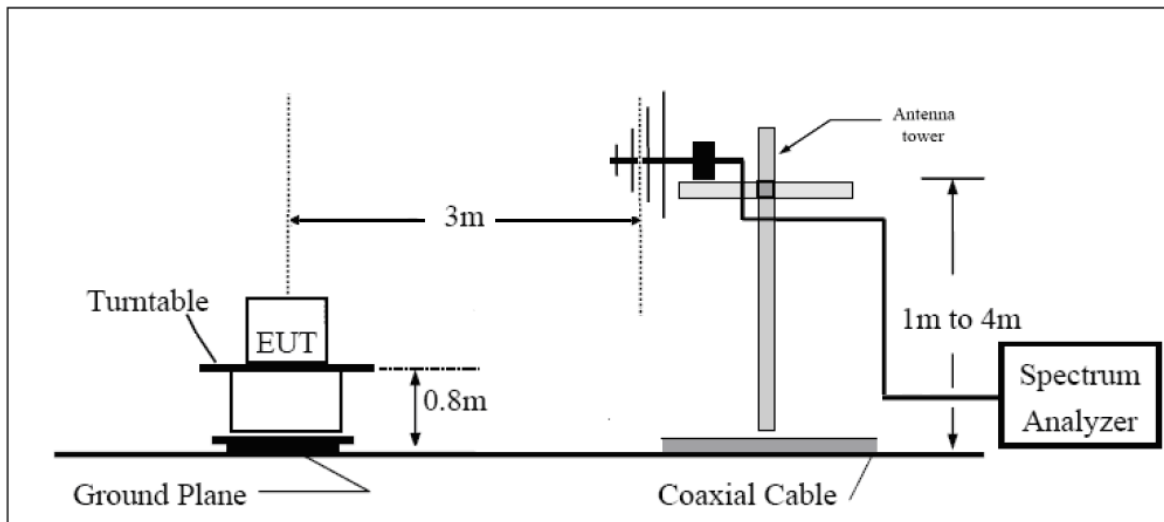

Above 1GHz

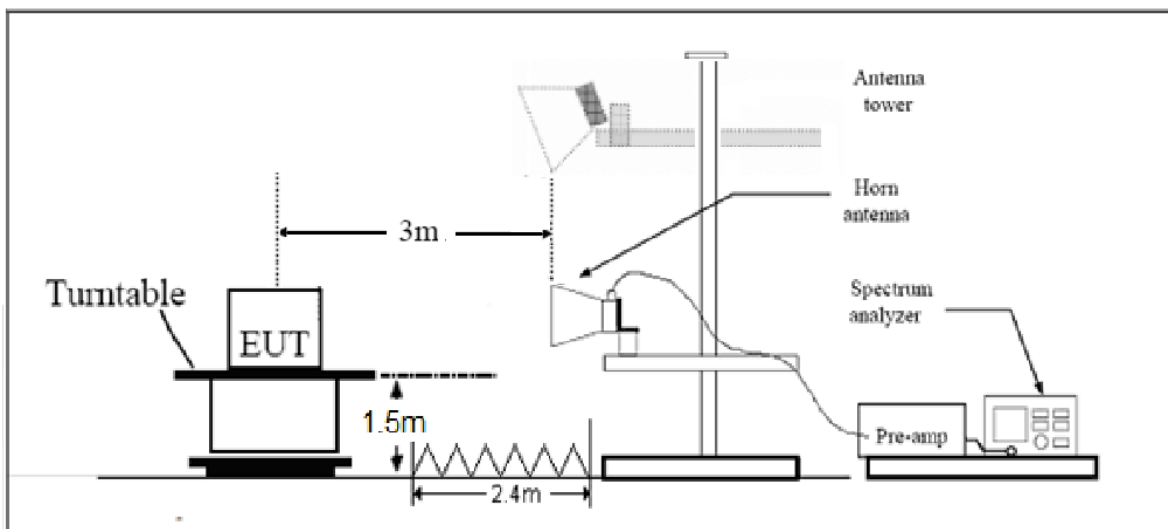

Note: Area side:2.4mX3.6m

Limits

- (1) For transmitters operating in the 5725-5850 MHz band: All emissions shall be limited to a level of -27 dBm/MHz at 75 MHz or more above or below the band edge increasing linearly to 10 dBm/MHz at 25 MHz above or below the band edge, and from 25 MHz above or below the band edge increasing linearly to a level of 15.6 dBm/MHz at 5 MHz above or below the band edge, and from 5 MHz above or below the band edge increasing linearly to a level of 27 dBm/MHz at the band edge.
- (2) For transmitters operating in the 5.15-5.25 GHz band: All emissions outside of the 5.15-5.35 GHz band shall not exceed an e.i.r.p. of -27 dBm/MHz(68.2dBμV/m).
- (3) For transmitters operating in the 5.25-5.35 GHz band: All emissions outside of the 5.15-5.35 GHz band shall not exceed an e.i.r.p. of -27 dBm/MHz(68.2dBμV/m).
- (4) For transmitters operating in the 5.47-5.725 GHz band: All emissions outside of the 5.47-5.725 GHz band shall not exceed an e.i.r.p. of -27 dBm/MHz(68.2dBμV/m).

Note: the following formula is used to convert the EIRP to field strength

§1、 $E[\text{dB}\mu\text{V}/\text{m}] = \text{EIRP}[\text{dBm}] - 20 \log(d[\text{meters}]) + 104.77$, where E = field strength and

d = distance at which field strength limit is specified in the rules;

§2、 $E[\text{dB}\mu\text{V}/\text{m}] = \text{EIRP}[\text{dBm}] + 95.2$, for d = 3 meters

- (5) Unwanted spurious emissions fallen in restricted bands per FCC Part15.205 shall comply with the general field strength limits set forth in § 15.209 as below table.

Frequency of emission (MHz)	Field strength(uV/m)	Field strength(dBuV/m)
0.009–0.490	2400/F(kHz)	/
0.490–1.705	24000/F(kHz)	/
1.705–30.0	30	/
30-88	100	40
88-216	150	43.5
216-960	200	46
Above960	500	54



MHz	MHz	MHz	GHz
0.090 - 0.110	16.42 - 16.423	399.9 - 410	4.5 - 5.15
0.495 - 0.505	16.69475 - 16.69525	608 - 614	5.35 - 5.46
2.1735 - 2.1905	16.80425 - 16.80475	960 - 1240	7.25 - 7.75
4.125 - 4.128	25.5 - 25.67	1300 - 1427	8.025 - 8.5
4.17725 - 4.17775	37.5 - 38.25	1435 - 1626.5	9.0 - 9.2
4.20725 - 4.20775	73 - 74.6	1645.5 - 1646.5	9.3 - 9.5
6.215 - 6.218	74.8 - 75.2	1660 - 1710	10.6 - 12.7
6.26775 - 6.26825	108 - 121.94	1718.8 - 1722.2	13.25 - 13.4
6.31175 - 6.31225	123 - 138	2200 - 2300	14.47 - 14.5
8.291 - 8.294	149.9 - 150.05	2310 - 2390	15.35 - 16.2
8.362 - 8.366	156.52475 - 156.52525	2483.5 - 2500	17.7 - 21.4
8.37625 - 8.38675	156.7 - 156.9	2690 - 2900	22.01 - 23.12
8.41425 - 8.41475	162.0125 - 167.17	3260 - 3267	23.6 - 24.0
12.29 - 12.293	167.72 - 173.2	3332 - 3339	31.2 - 31.8
12.51975 - 12.52025	240 - 285	3345.8 - 3358	36.43 - 36.5
12.57675 - 12.57725	322 - 335.4	3600 - 4400	(²)
13.36 - 13.41			

Measurement Uncertainty

The assessed measurement uncertainty to ensure 95% confidence level for the normal distribution is with the coverage factor $k = 1.96$.

Frequency	Uncertainty
9KHz-30MHz	3.55 dB
30MHz-200MHz	4.19 dB
200MHz-1GHz	3.63 dB
1GHz-26.5G	3.68 dB
26.5G-40GHz	4.76dB



Test Results:

The signal beyond the limit is carrier.

U-NII-1

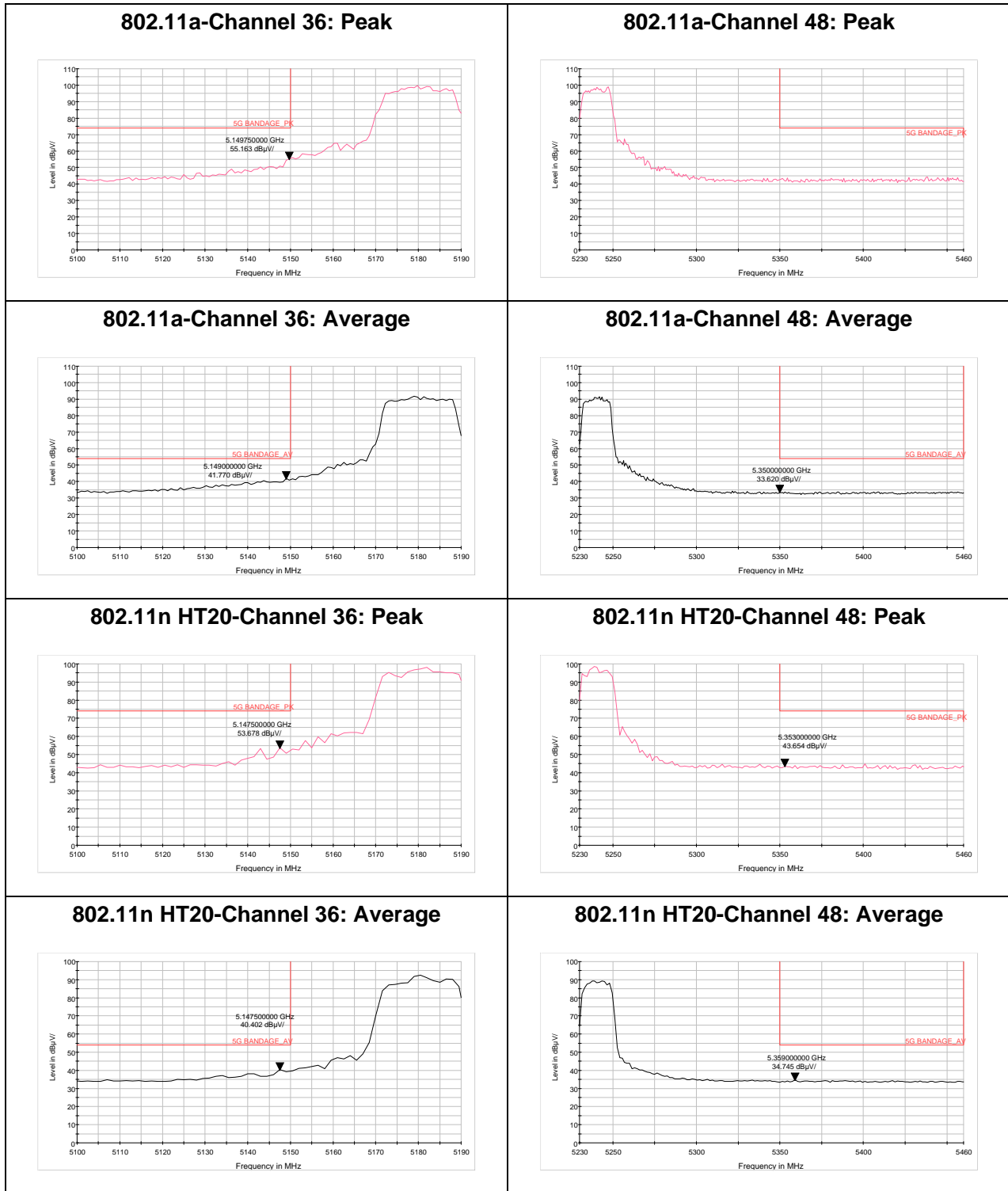



802.11n HT40-Channel 38: Peak

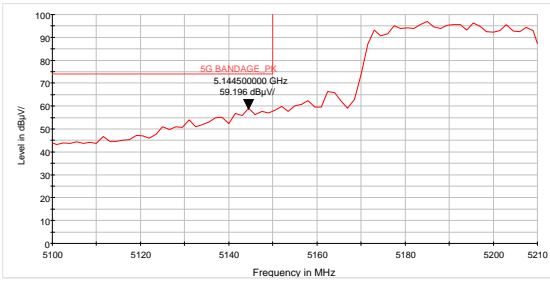

802.11n HT40-Channel 46: Peak

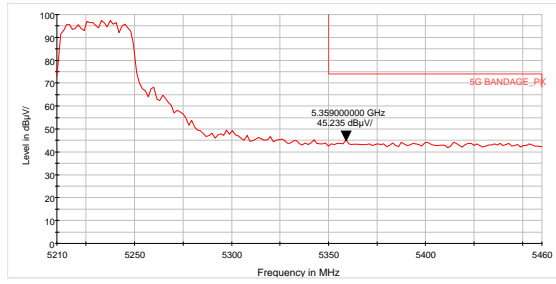

802.11n HT40-Channel 38: Average

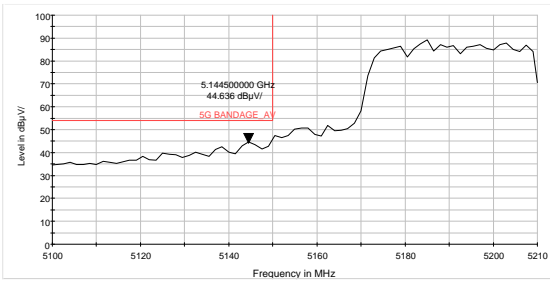

802.11n HT40-Channel 46: Average

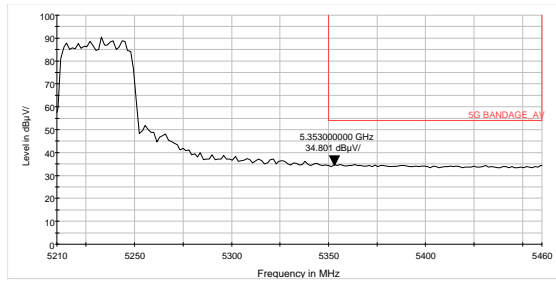

802.11ac HT20 -Channel 36: Peak

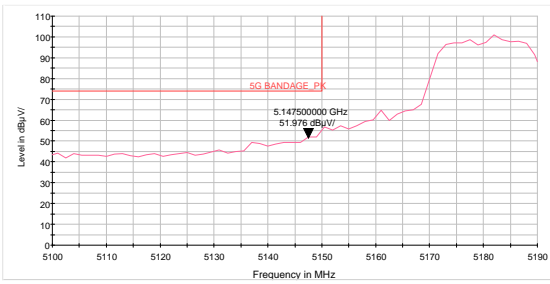

802.11ac HT20 -Channel 48: Peak

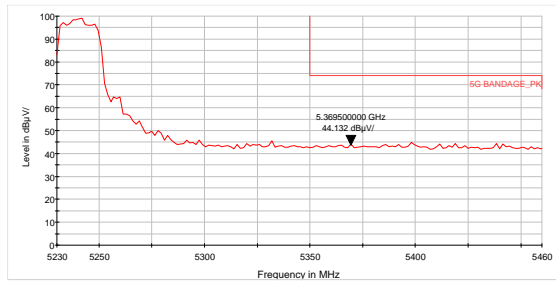

802.11ac HT20-Channel 36: Average

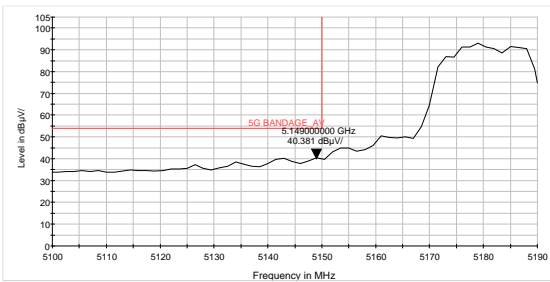

802.11ac HT20 -Channel 48: Average

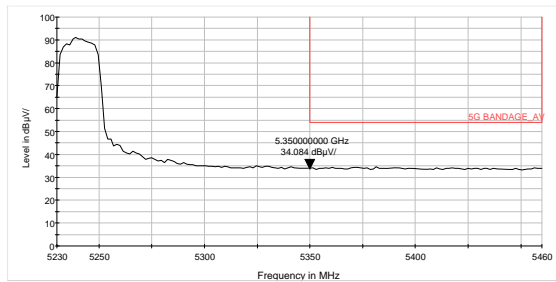



802.11ac HT40-Channel 38: Peak

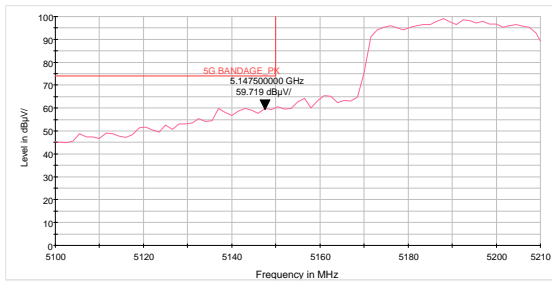

802.11ac HT40-Channel 46: Peak

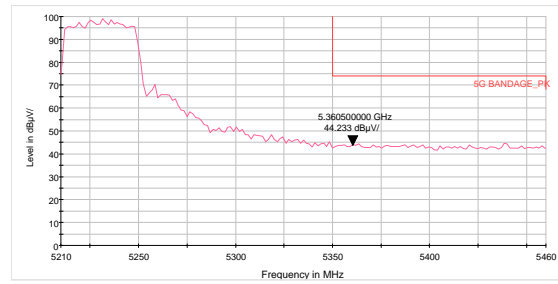

802.11ac HT40-Channel 38: Average

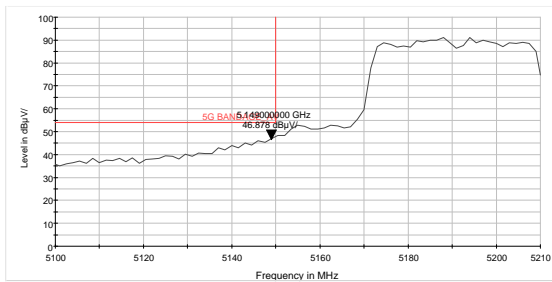

802.11ac HT40-Channel 46: Average

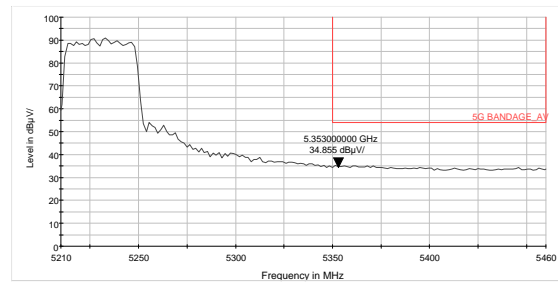

802.11ac HT80 -Channel 42: Peak

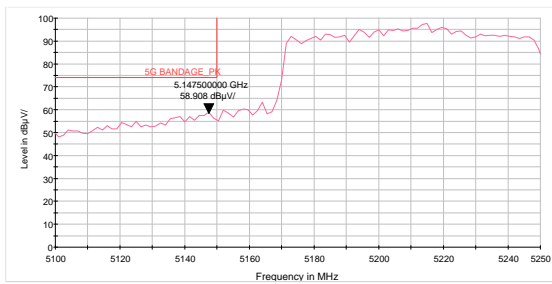

802.11ac HT80- Channel 42: Average

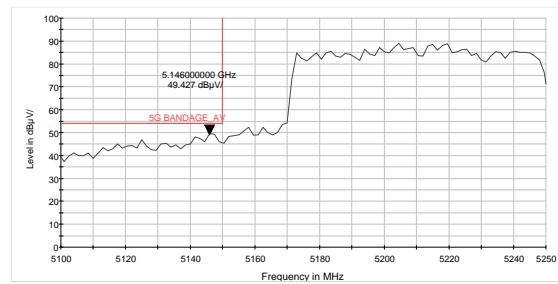



U-NII-2A

802.11a-Channel 52: Peak

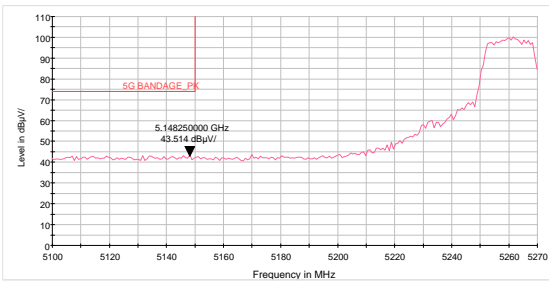

802.11a-Channel 64: Peak

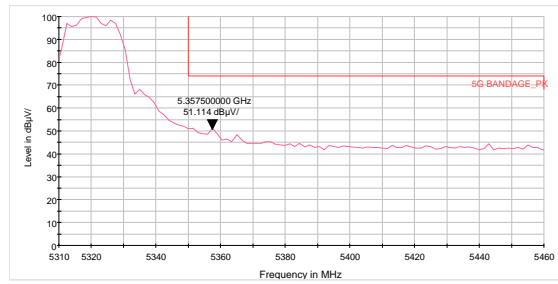

802.11a-Channel 52: Average

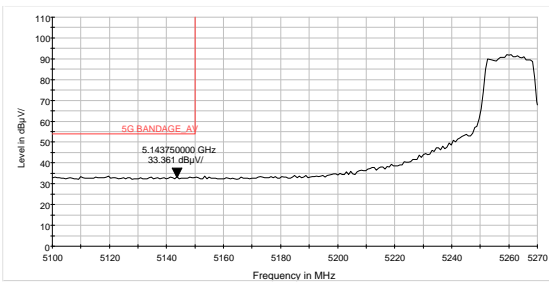

802.11a-Channel 64: Average

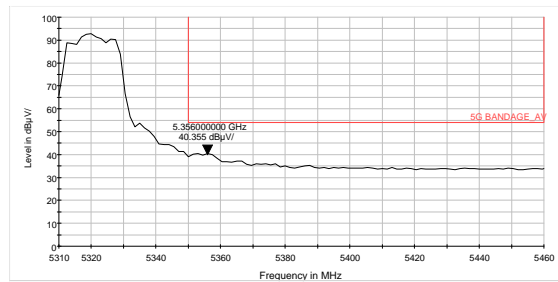

802.11n HT20-Channel 52: Peak

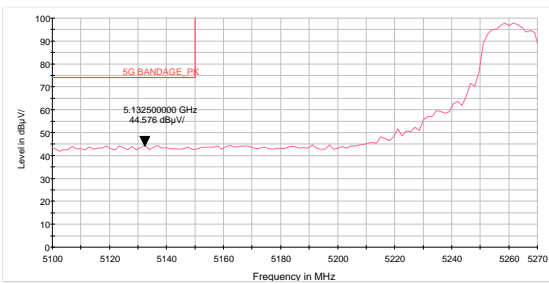

802.11n HT20-Channel 64: Peak

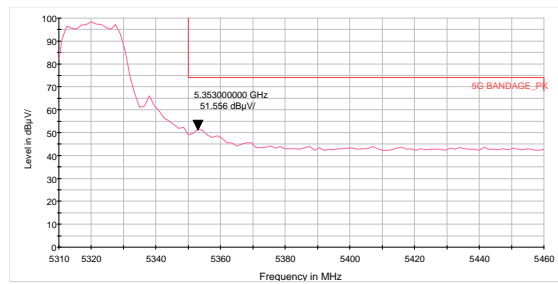

802.11n HT20-Channel 52: Average

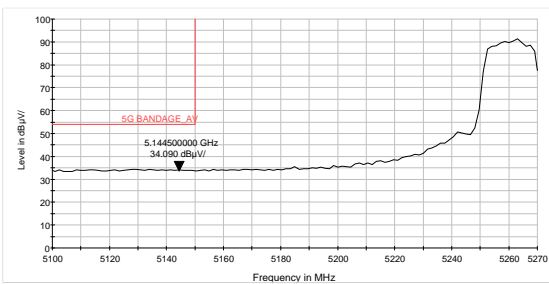

802.11n HT20-Channel 64: Average

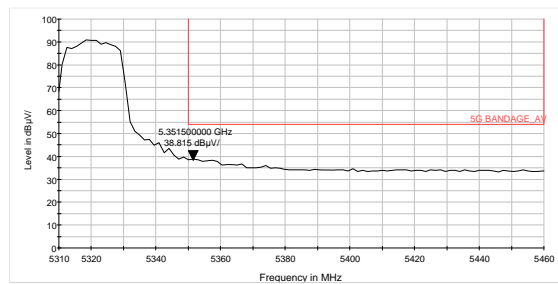



802.11n HT40-Channel 54: Peak

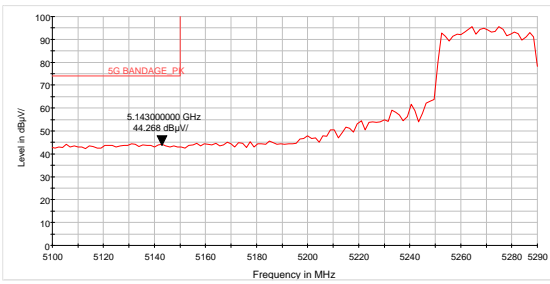

802.11n HT40-Channel 62: Peak

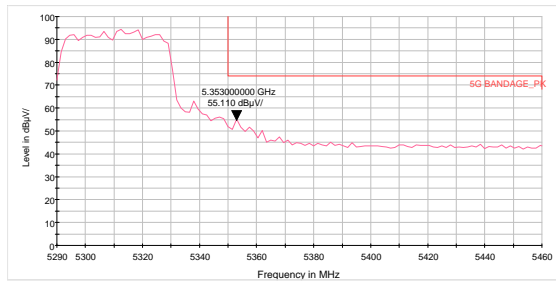

802.11n HT40-Channel 54: Average

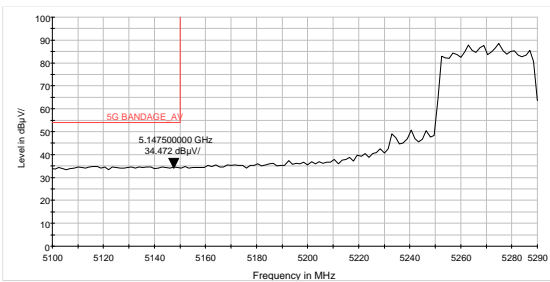

802.11n HT40-Channel 62: Average

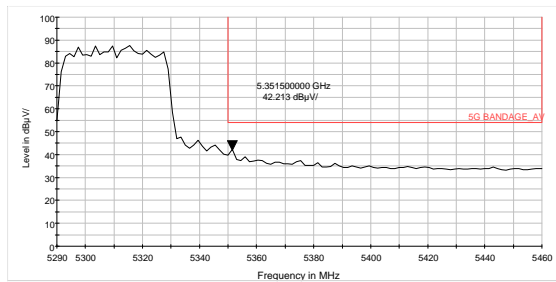

802.11ac HT20 -Channel 52: Peak

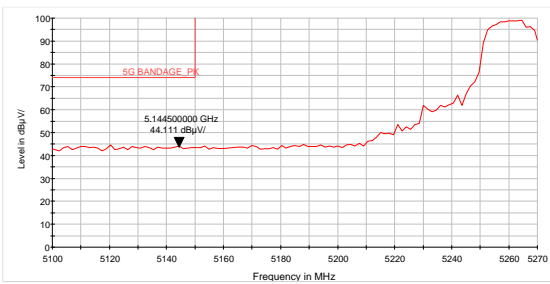

802.11ac HT20 -Channel 64: Peak

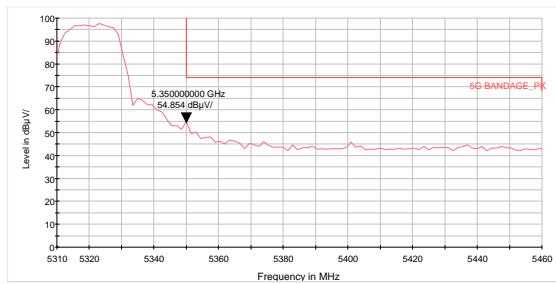

802.11ac HT20-Channel 52: Average

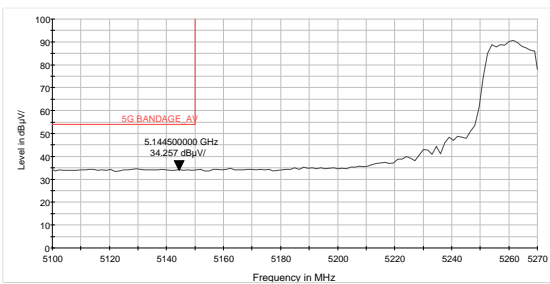

802.11ac HT20 -Channel 64: Average

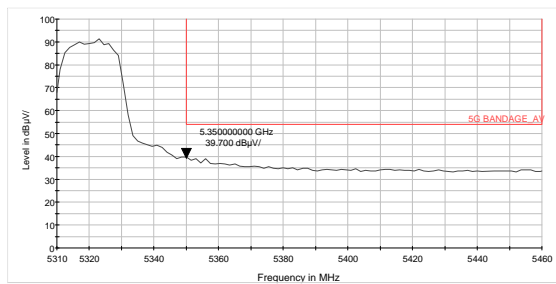



802.11ac HT40-Channel 54: Peak

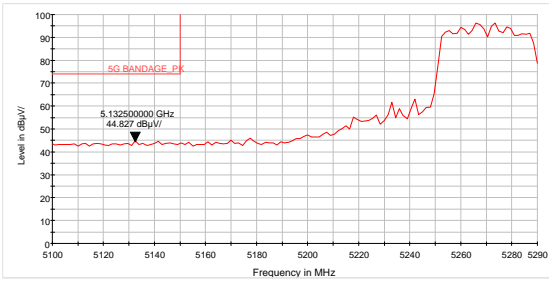

802.11ac HT40-Channel 62: Peak

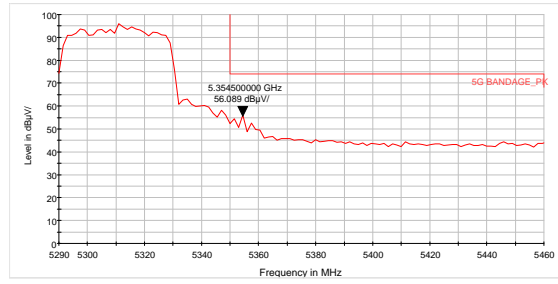

802.11ac HT40-Channel 54: Average

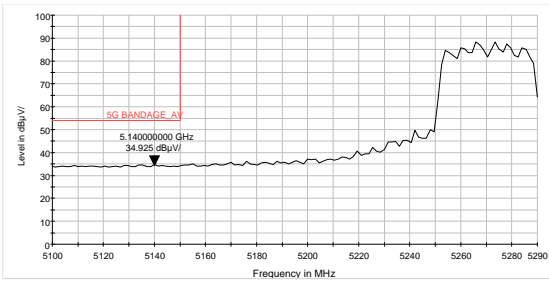

802.11ac HT40-Channel 62: Average

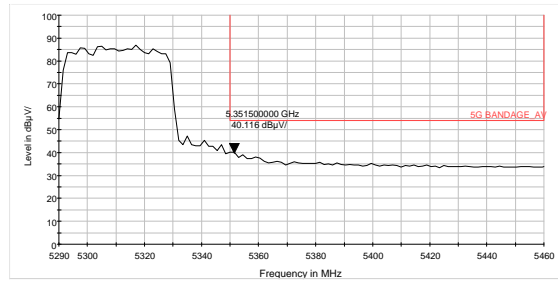

802.11ac HT80 -Channel 58: Peak

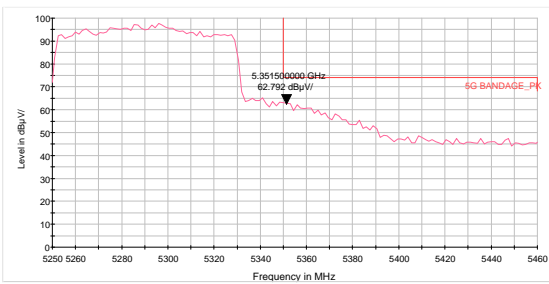

802.11ac HT80- Channel 58: Average

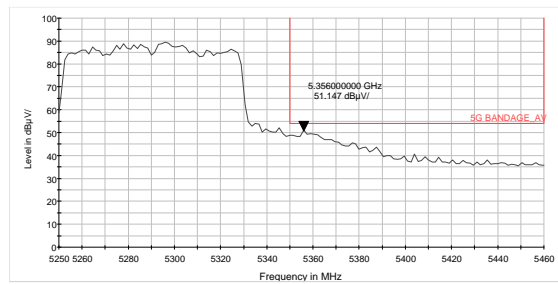



U-NII-2C

802.11a-Channel 100: Peak

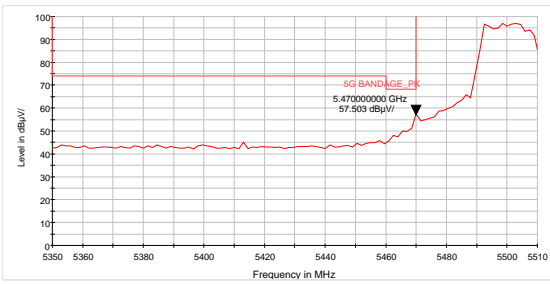

802.11a-Channel 140: Peak

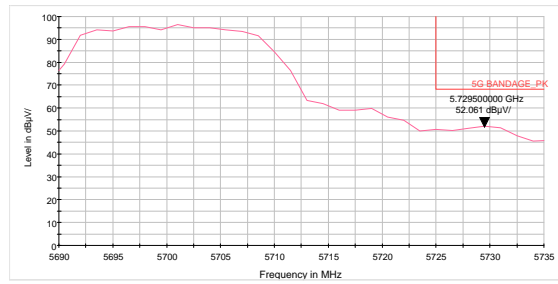

802.11a-Channel 100: Average

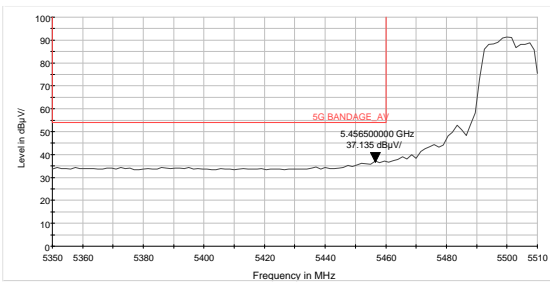

802.11n HT20-Channel 100: Peak

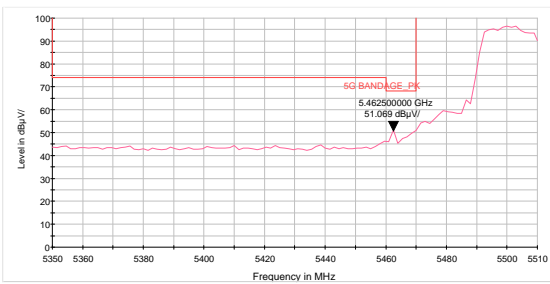

802.11n HT20-Channel 140: Peak

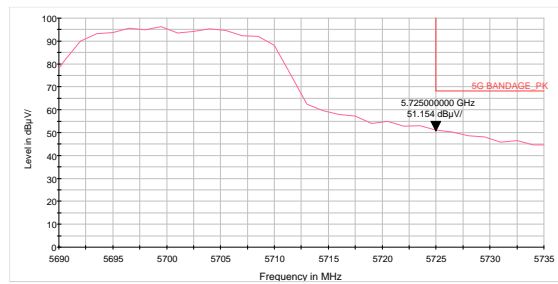

802.11n HT20-Channel 100: Average

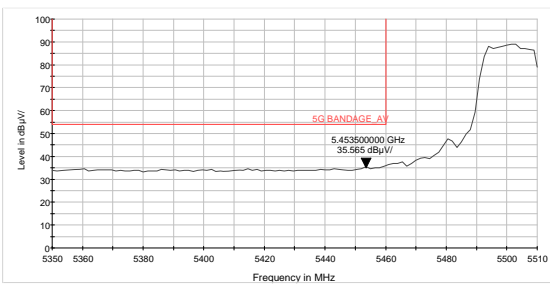



802.11n HT40-Channel 102: Peak

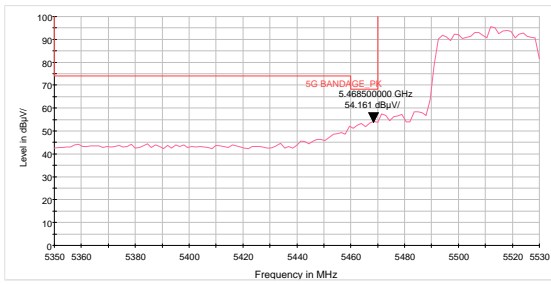

802.11n HT40-Channel 134: Peak

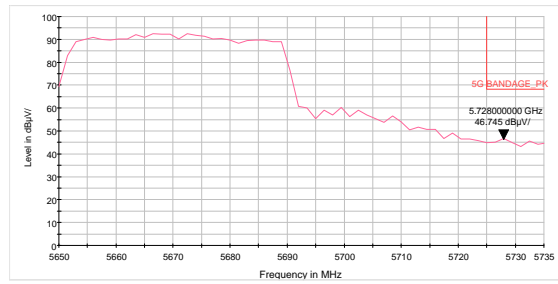

802.11n HT40-Channel 102: Average

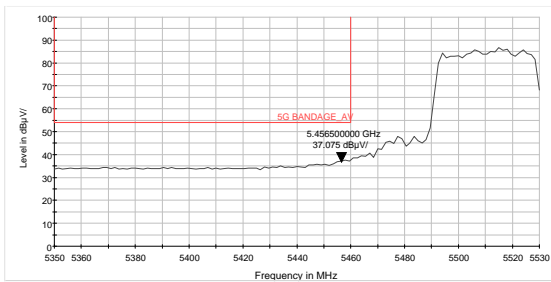

802.11ac HT20 -Channel 140: Peak

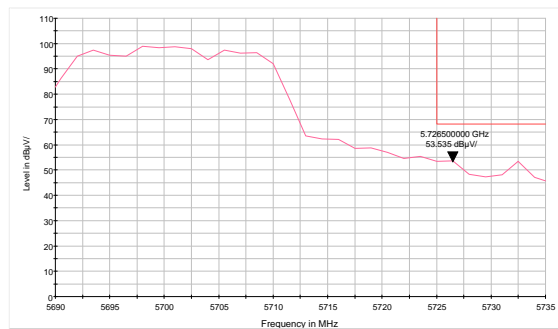

802.11ac HT20 -Channel 100: Peak

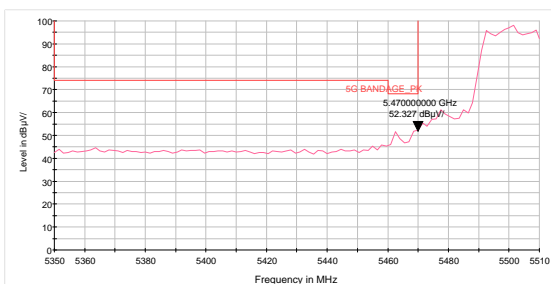

802.11ac HT20-Channel 100: Average

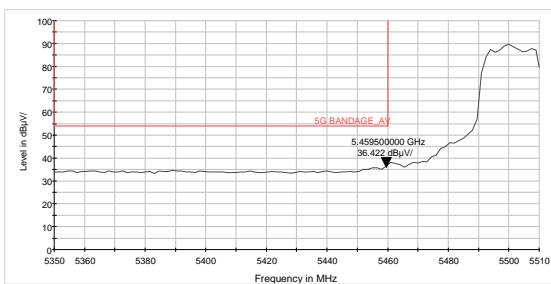



802.11ac HT40-Channel 102: Peak

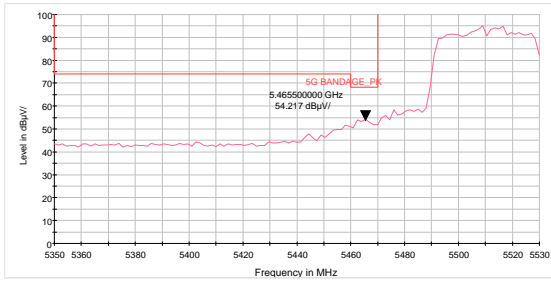

802.11ac HT40-Channel 134: Peak

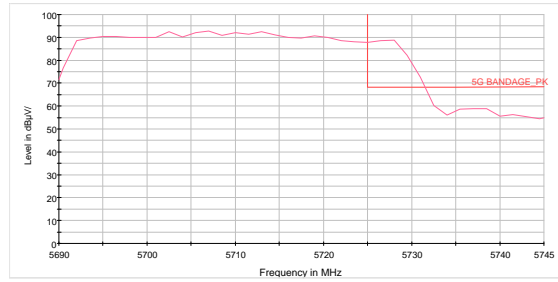

802.11ac HT40-Channel 102: Average

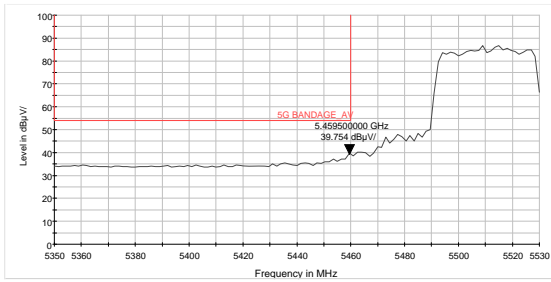

802.11ac HT80 -Channel 106: Peak

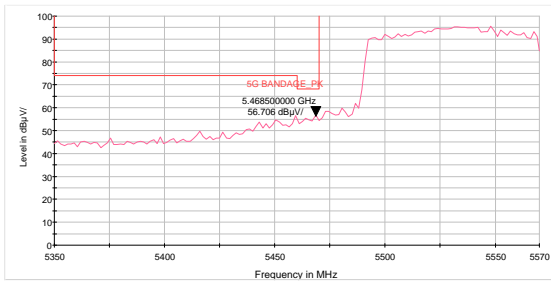

802.11ac HT80 -Channel 138: Peak

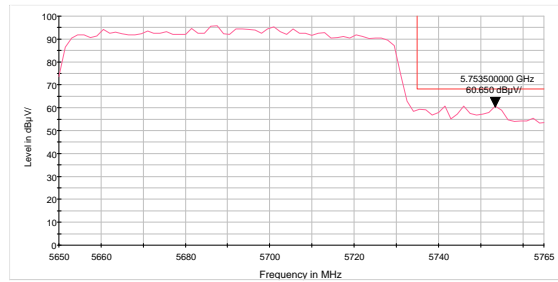

802.11ac HT80- Channel 106: Average

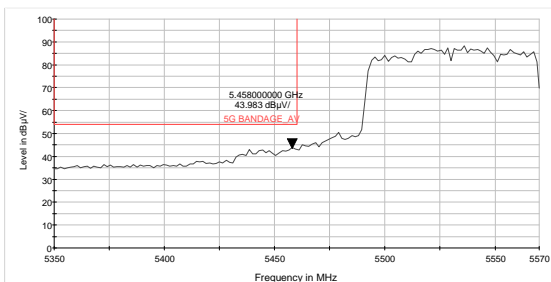



U-NII-3

802.11a-Channel 149: Peak

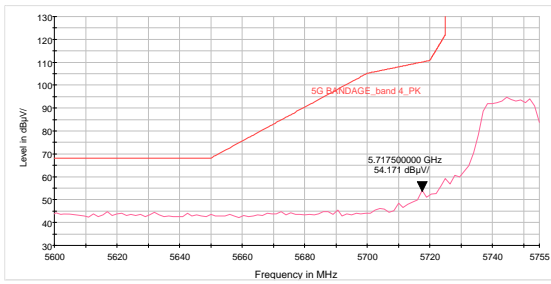

802.11a-Channel 165: Peak

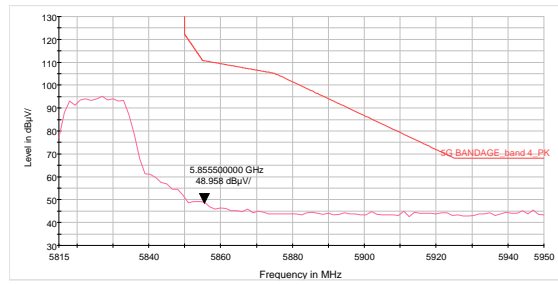

802.11n HT20-Channel 149: Peak

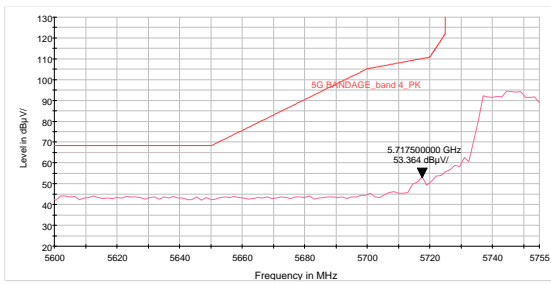

802.11n HT20-Channel 165: Peak

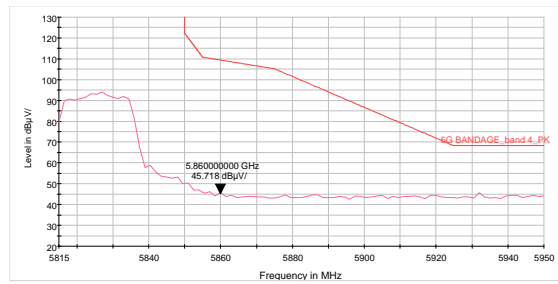

802.11n HT40-Channel 151: Peak

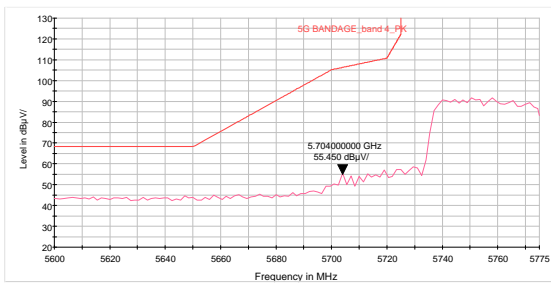

802.11n HT40-Channel 159: Peak

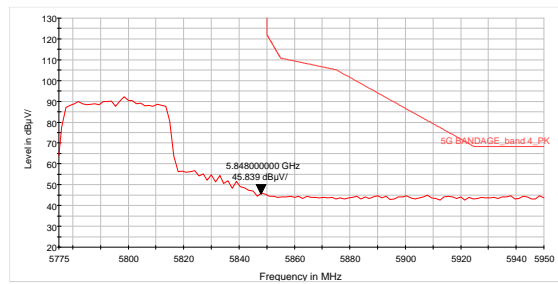

802.11ac HT20-Channel 149: Peak

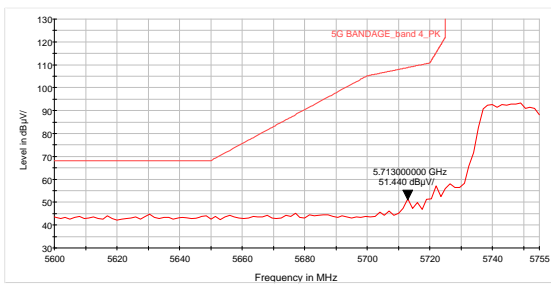

802.11ac HT20-Channel 165: Peak

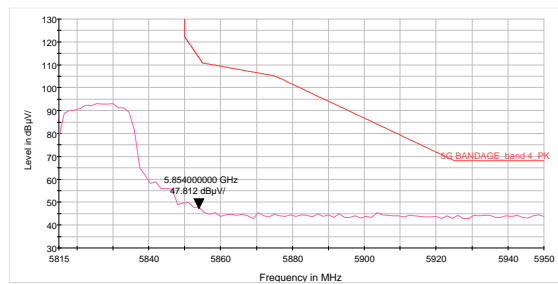



802.11ac HT40-Channel 151: Peak

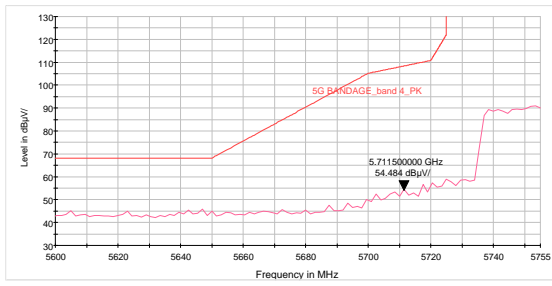

802.11ac HT40-Channel 159: Peak

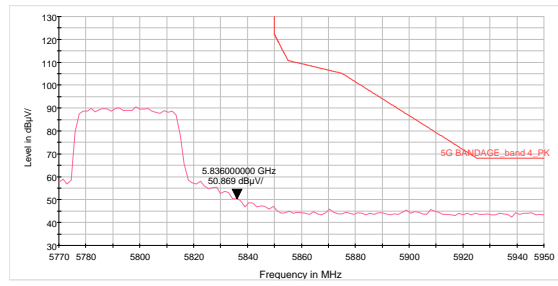

802.11ac HT80- Channel 155: Peak

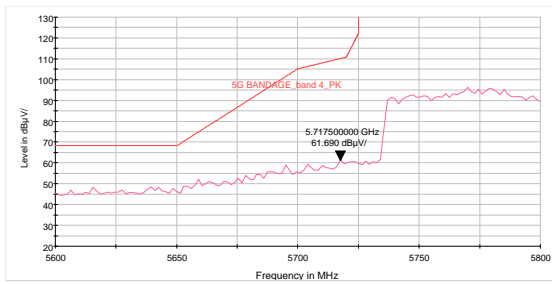

Result of RE**Test result**

Sweep the whole frequency band through the range from 9kHz to the 10th harmonic of the carrier, and 9KHz-30MHz, the emissions more than 20 dB below the permissible value are not reported.

Continuous TX mode:

RE EN301489 0.03-1GHz QP Class B

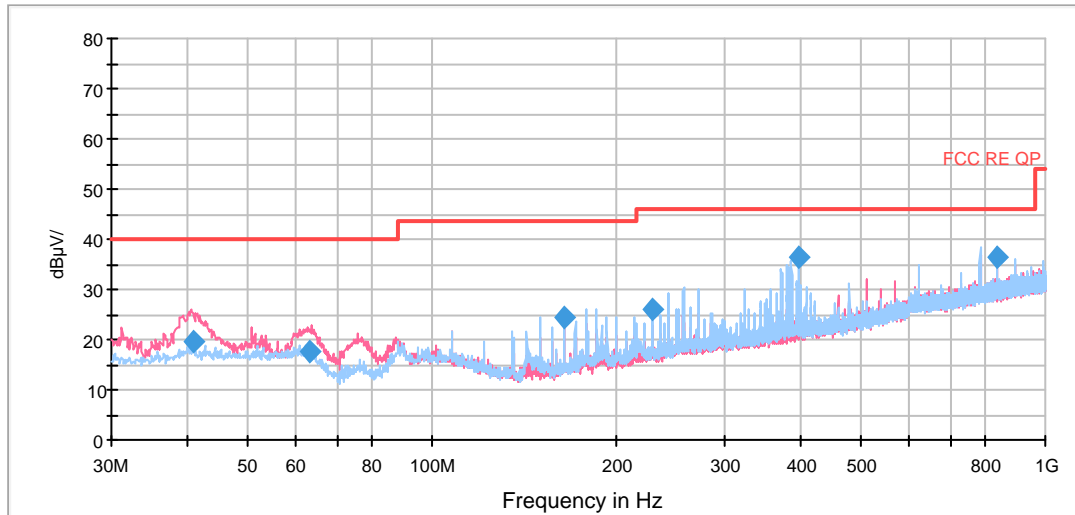

Radiates Emission from 30MHz to 1GHz



802.11a CH36

Frequency (MHz)	Peak (dBuV/m)	Height (cm)	Polarization	Azimuth (deg)	Reading value (dBuV/m)	Correct Factor (dB)	Margin (dB)	Limit (dBuV/m)
1348.000000	38.5	100.0	V	56.0	45.8	-7.3	35.5	74
1870.750000	40.1	100.0	H	239.0	44.2	-4.1	33.9	74
2316.250000	42.6	100.0	V	6.0	44.3	-1.7	31.4	74
2783.500000	44.9	100.0	V	1.0	45.4	-0.5	29.1	74
4714.750000	45.2	100.0	H	310.0	43.7	1.5	28.8	74
6587.500000	50.8	100.0	H	350.0	43.3	7.5	23.2	74

Remark: 1. Correction Factor = Antenna factor+ Insertion loss (cable loss + amplifier gain)

Frequency (MHz)	Average (dBuV/m)	Height (cm)	Polarization	Azimuth (deg)	Reading value (dBuV/m)	Correct Factor (dB)	Margin (dB)	Limit (dBuV/m)
1378.000000	28.6	100.0	V	213.0	35.7	-7.1	25.4	54
1897.000000	31.8	100.0	V	128.0	35.9	-4.1	22.2	54
2376.250000	32.1	100.0	H	345.0	33.5	-1.4	21.9	54
2778.250000	36.9	100.0	V	1.0	37.4	-0.5	17.1	54
4747.000000	33.7	100.0	V	244.0	32.1	1.6	20.3	54
6676.000000	39.3	100.0	H	290.0	32.3	7.0	14.7	54

Remark: 1. Correction Factor = Antenna factor+ Insertion loss (cable loss + amplifier gain)

FCC RE 1G-18GHz PK+AV Class B

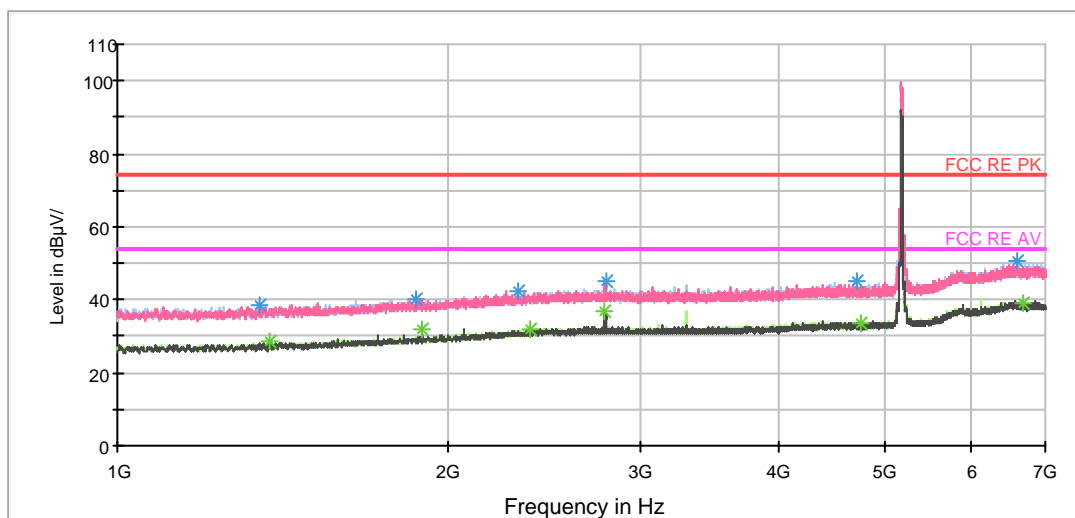

Radiates Emission from 1GHz to 7GHz
Note: The signal beyond the limit is carrier.

RE 3-18GHz PK+AV

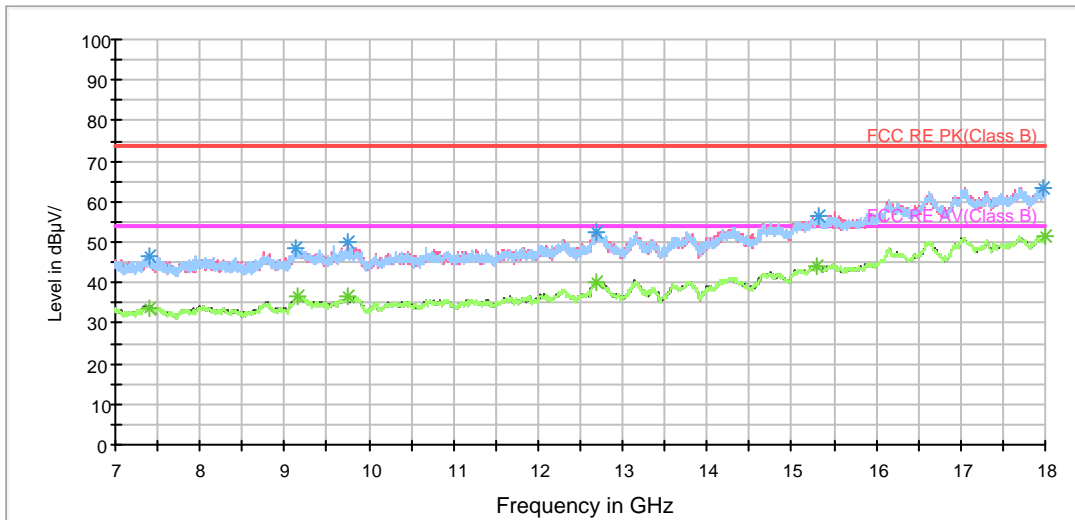

Radiates Emission from 7GHz to 18GHz

RE 18-26.5GHz PK+AV

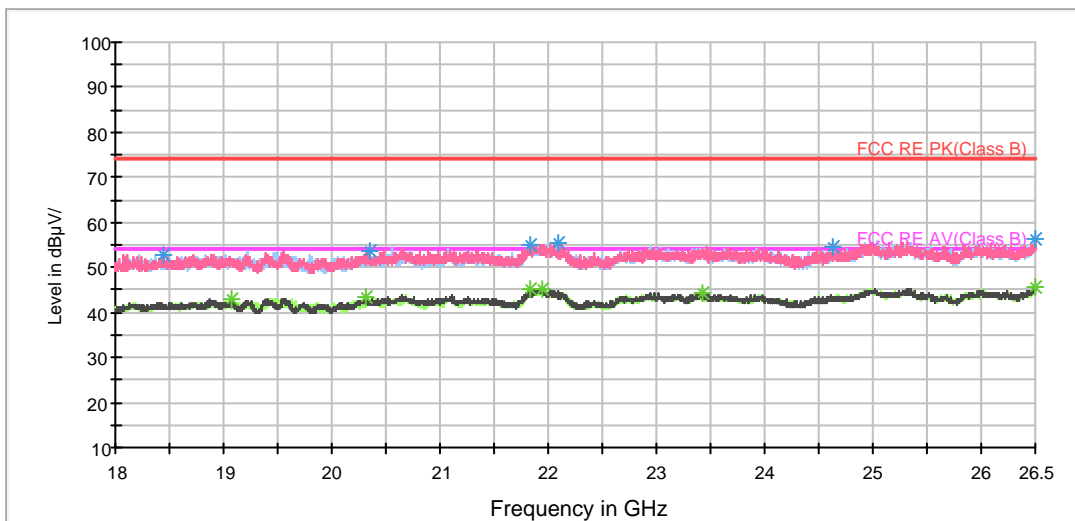

Radiates Emission from 18GHz to 26.5GHz

BELL RE 26.5-40GHz PK+AV

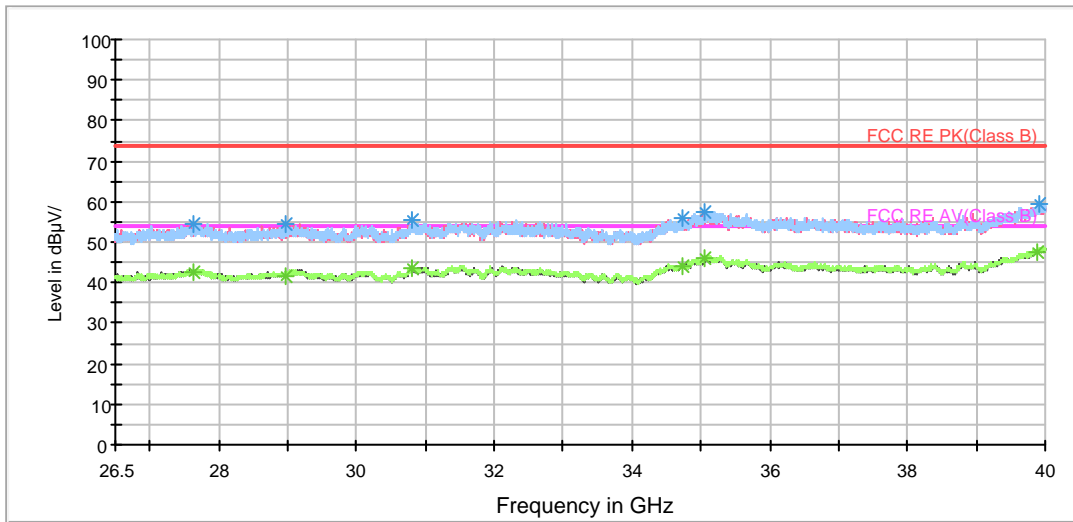

Radiates Emission from 26.5GHz to 40GHz



802.11a CH40

Frequency (MHz)	Peak (dBuV/m)	Height (cm)	Polarization	Azimuth (deg)	Reading value (dBuV/m)	Correct Factor (dB)	Margin (dB)	Limit (dBuV/m)
1287.250000	37.9	100.0	H	356.0	45.6	-7.7	36.1	74
1871.500000	39.4	100.0	V	55.0	43.5	-4.1	34.6	74
2567.500000	42.1	100.0	H	0.0	42.9	-0.8	31.9	74
3299.500000	43.6	100.0	H	0.0	43.7	-0.1	30.4	74
4141.000000	44.1	100.0	H	339.0	43.2	0.9	29.9	74
5766.250000	48.0	100.0	V	0.0	42.9	5.1	26.0	74

Remark: 1. Correction Factor = Antenna factor+ Insertion loss (cable loss + amplifier gain)

Frequency (MHz)	Average (dBuV/m)	Height (cm)	Polarization	Azimuth (deg)	Reading value (dBuV/m)	Correct Factor (dB)	Margin (dB)	Limit (dBuV/m)
1299.250000	27.2	100.0	H	236.0	34.8	-7.6	26.8	54
1897.000000	30.9	100.0	V	123.0	35.0	-4.1	23.1	54
2599.750000	32.1	100.0	V	55.0	32.9	-0.8	21.9	54
3300.250000	35.5	100.0	H	0.0	35.6	-0.1	18.5	54
4160.500000	33.1	100.0	V	228.0	31.8	1.3	20.9	54
5865.250000	37.8	100.0	H	186.0	32.1	5.7	16.2	54

Remark: 1. Correction Factor = Antenna factor+ Insertion loss (cable loss + amplifier gain)

FCC RE 1G-18GHz PK+AV Class B

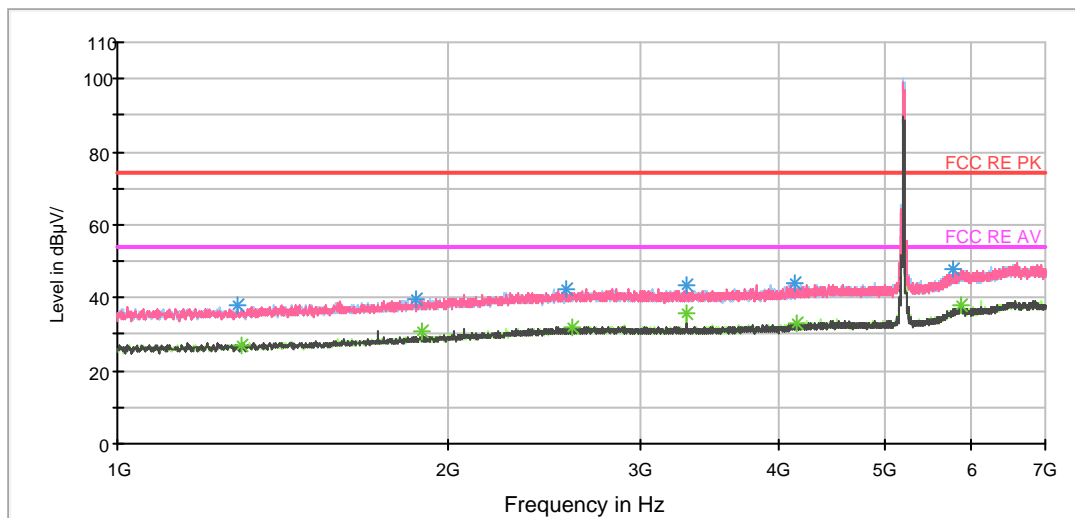

Radiates Emission from 1GHz to 7GHz
Note: The signal beyond the limit is carrier.



RE 3-18GHz PK+AV

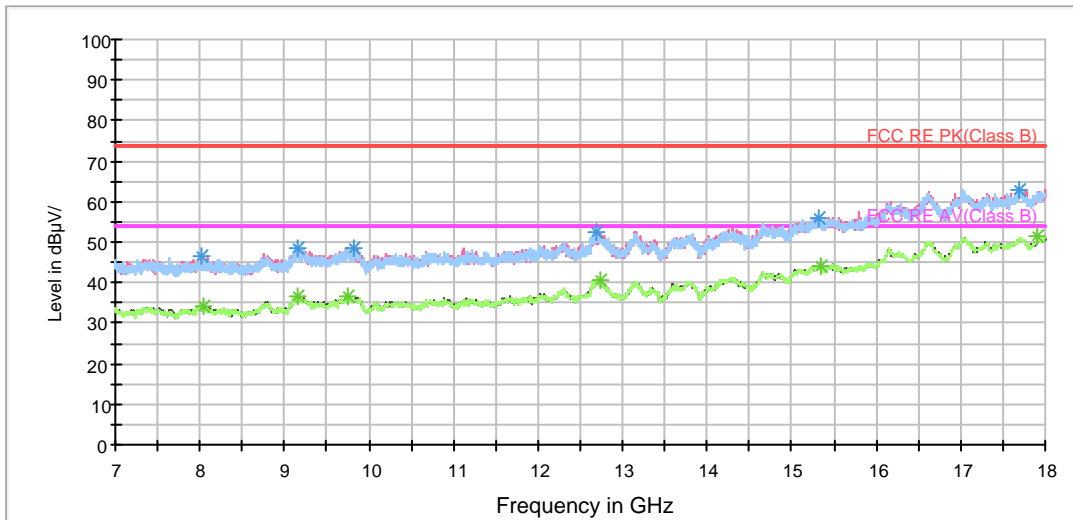

Radiates Emission from 7GHz to 18GHz

RE 18-26.5GHz PK+AV

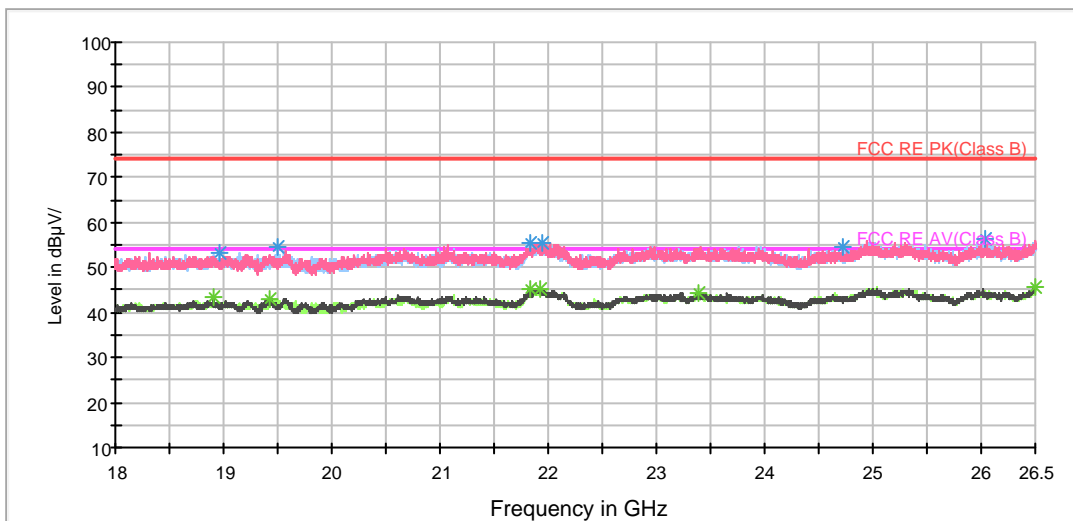

Radiates Emission from 18GHz to 26.5GHz

BELL RE 26.5-40GHz PK+AV

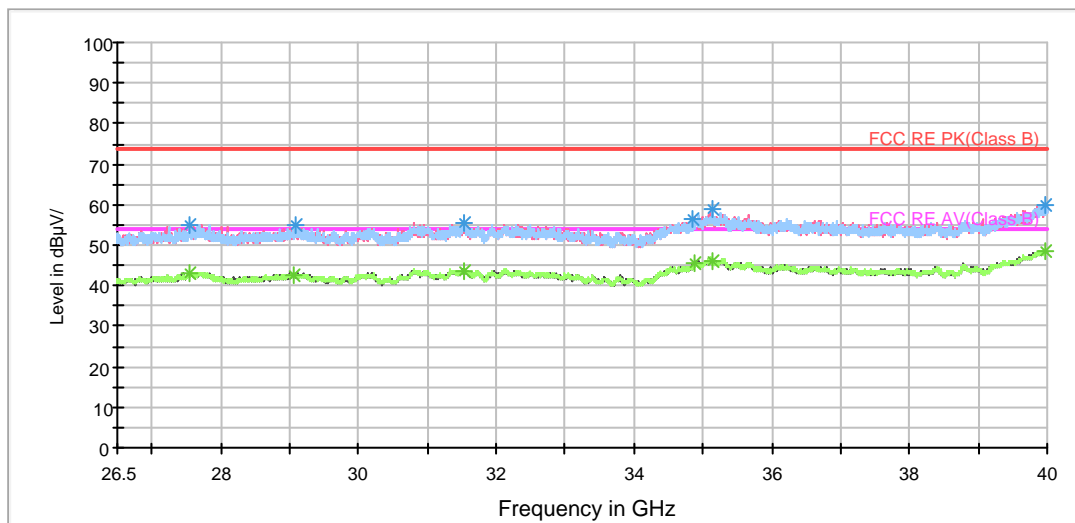

Radiates Emission from 26.5GHz to 40GHz



802.11a CH48

Frequency (MHz)	Peak (dBuV/m)	Height (cm)	Polarization	Azimuth (deg)	Reading value (dBuV/m)	Correct Factor (dB)	Margin (dB)	Limit (dBuV/m)
1255.750000	37.7	100.0	V	58.0	45.5	-7.8	36.3	74
1850.500000	39.8	100.0	H	0.0	44.1	-4.3	34.2	74
2645.500000	42.0	100.0	H	190.0	42.8	-0.8	32.0	74
3299.500000	42.9	100.0	H	289.0	43.0	-0.1	31.1	74
4639.000000	44.6	100.0	V	38.0	42.9	1.7	29.4	74
6660.250000	48.8	100.0	H	356.0	41.9	6.9	25.2	74

Remark: 1. Correction Factor = Antenna factor+ Insertion loss (cable loss + amplifier gain)

Frequency (MHz)	Average (dBuV/m)	Height (cm)	Polarization	Azimuth (deg)	Reading value (dBuV/m)	Correct Factor (dB)	Margin (dB)	Limit (dBuV/m)
1267.000000	27.3	100.0	V	136.0	35.1	-7.8	26.7	54
1897.750000	29.7	100.0	V	116.0	33.8	-4.1	24.3	54
2565.250000	32.2	100.0	H	8.0	33.0	-0.8	21.8	54
3300.250000	35.3	100.0	H	22.0	35.4	-0.1	18.7	54
4778.500000	33.6	100.0	H	210.0	32.0	1.6	20.4	54
6568.750000	39.1	100.0	V	1.0	31.7	7.4	14.9	54

Remark: 1. Correction Factor = Antenna factor+ Insertion loss (cable loss + amplifier gain)

FCC RE 1G-18GHz PK+AV Class B

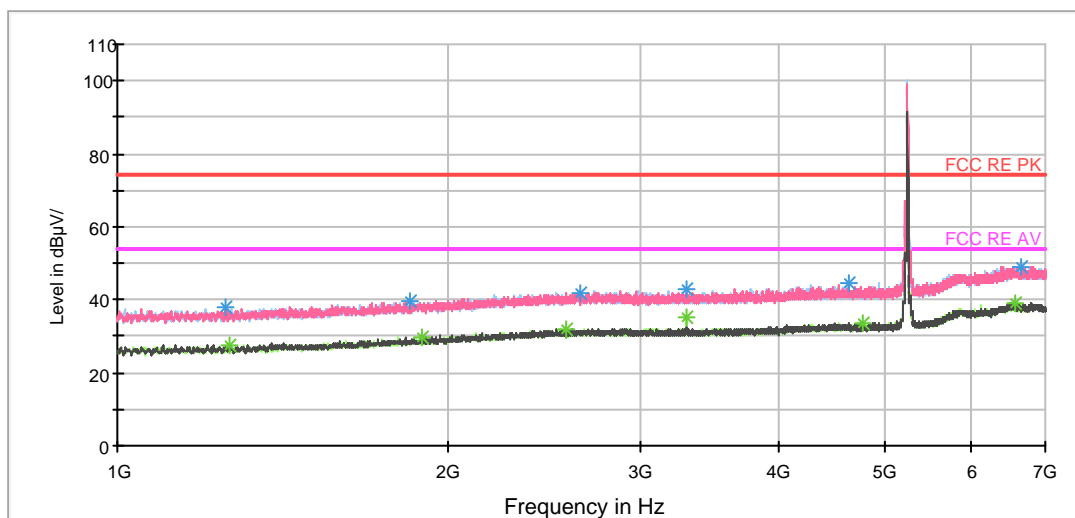

Radiates Emission from 1GHz to 7GHz
Note: The signal beyond the limit is carrier.

RE 3-18GHz PK+AV

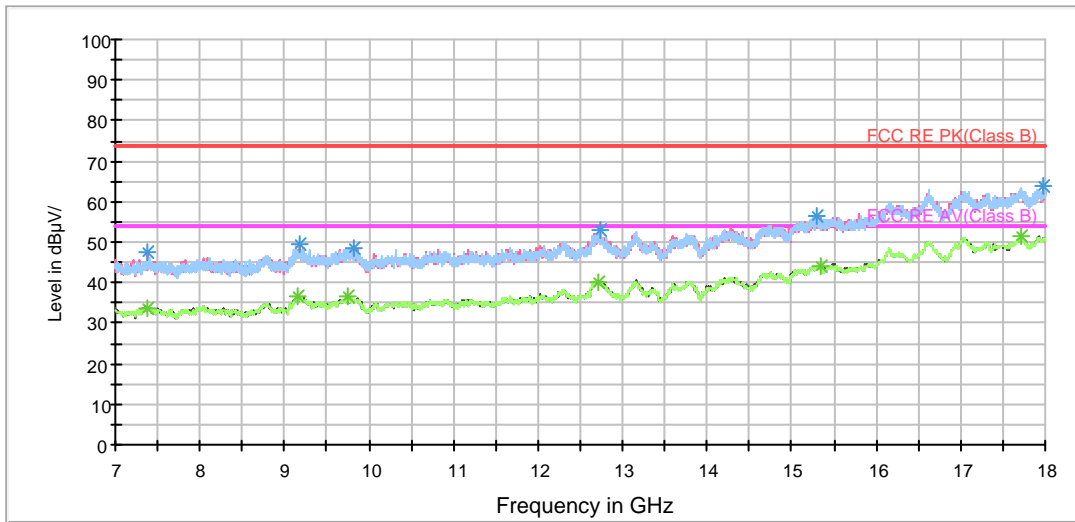

Radiates Emission from 7GHz to 18GHz

RE 18-26.5GHz PK+AV

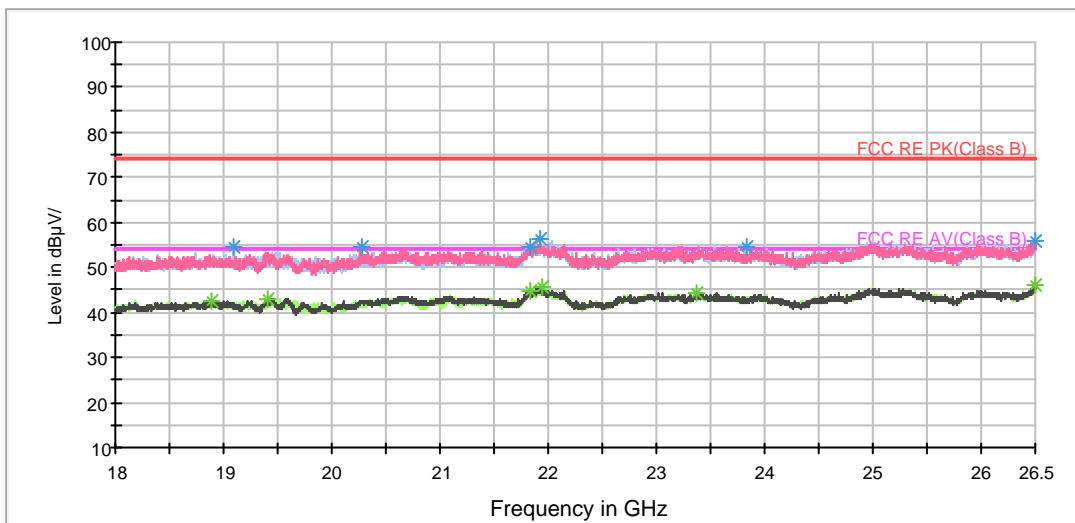

Radiates Emission from 18GHz to 26.5GHz

BELL RE 26.5-40GHz PK+AV

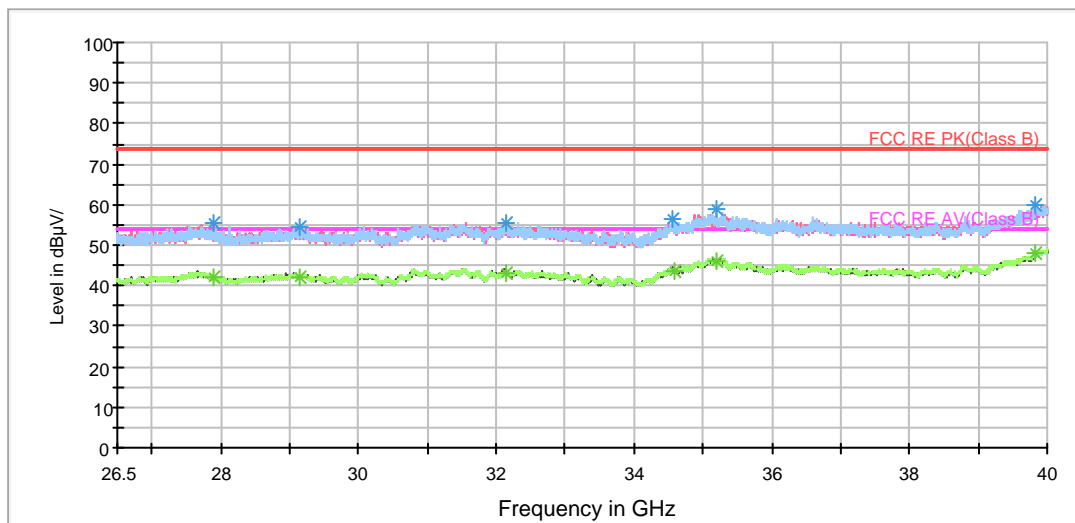

Radiates Emission from 26.5GHz to 40GHz



802.11a CH52

Frequency (MHz)	Peak (dBuV/m)	Height (cm)	Polarization	Azimuth (deg)	Reading value (dBuV/m)	Correct Factor (dB)	Margin (dB)	Limit (dBuV/m)
1119.250000	37.4	100.0	H	0.0	46.0	-8.6	36.6	74
1348.000000	38.1	100.0	V	53.0	45.4	-7.3	35.9	74
1886.500000	39.6	100.0	H	329.0	43.7	-4.1	34.4	74
3300.250000	42.7	100.0	H	352.0	42.8	-0.1	31.3	74
4612.750000	44.3	100.0	V	0.0	42.7	1.6	29.7	74
6109.750000	47.4	100.0	H	133.0	41.9	5.5	26.6	74

Remark: 1. Correction Factor = Antenna factor+ Insertion loss (cable loss + amplifier gain)

Frequency (MHz)	Average (dBuV/m)	Height (cm)	Polarization	Azimuth (deg)	Reading value (dBuV/m)	Correct Factor (dB)	Margin (dB)	Limit (dBuV/m)
1111.750000	27.1	100.0	H	329.0	35.7	-8.6	26.9	54
1344.250000	27.3	100.0	V	6.0	34.7	-7.4	26.7	54
1897.000000	30.0	100.0	V	6.0	34.1	-4.1	24.0	54
3300.250000	35.6	100.0	H	352.0	35.7	-0.1	18.4	54
4620.250000	33.5	100.0	H	21.0	31.9	1.6	20.5	54
6109.000000	39.1	100.0	H	291.0	33.6	5.5	14.9	54

Remark: 1. Correction Factor = Antenna factor+ Insertion loss (cable loss + amplifier gain)

FCC RE 1G-18GHz PK+AV Class B

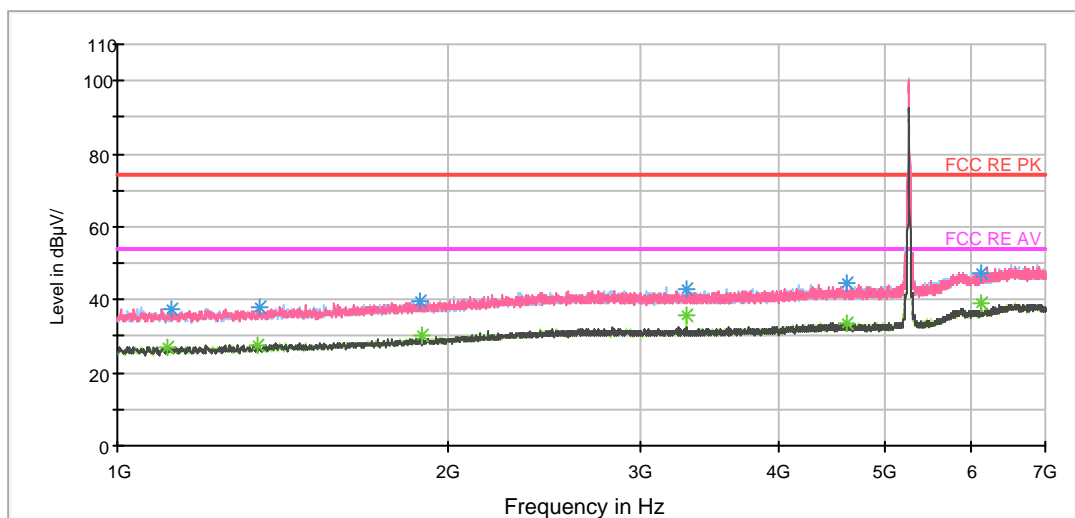

Radiates Emission from 1GHz to 7GHz
Note: The signal beyond the limit is carrier.

RE 3-18GHz PK+AV

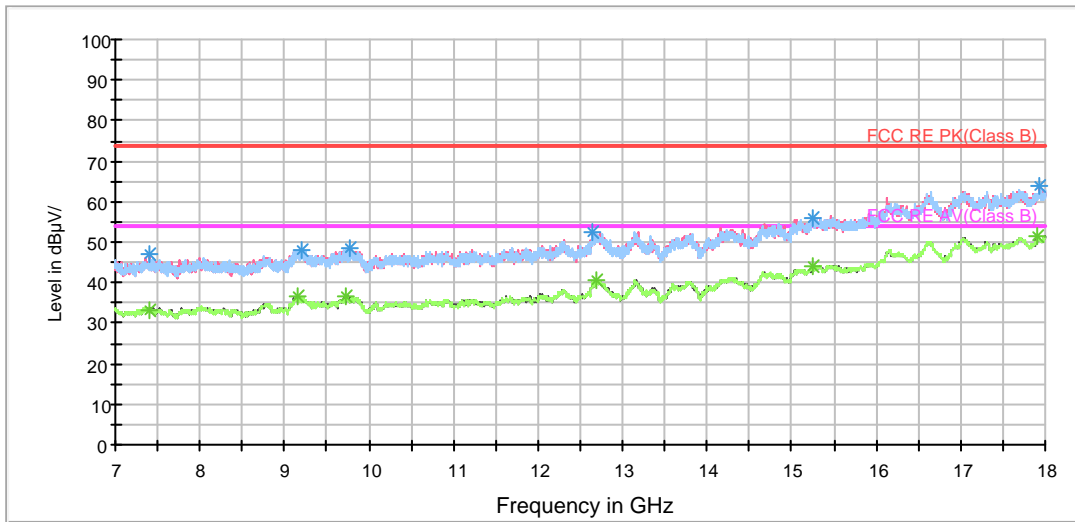

Radiates Emission from 7GHz to 18GHz

RE 18-26.5GHz PK+AV

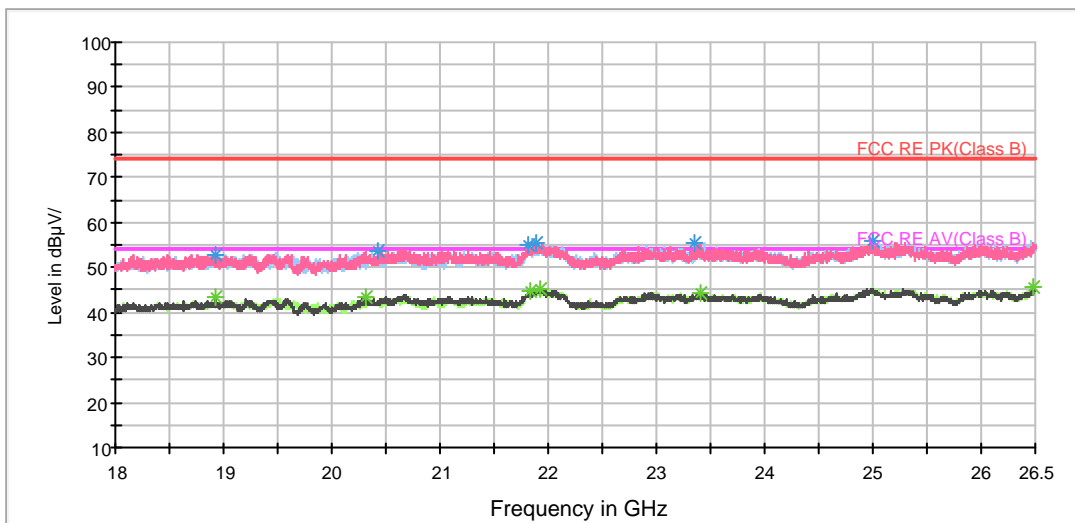

Radiates Emission from 18GHz to 26.5GHz

BELL RE 26.5-40GHz PK+AV

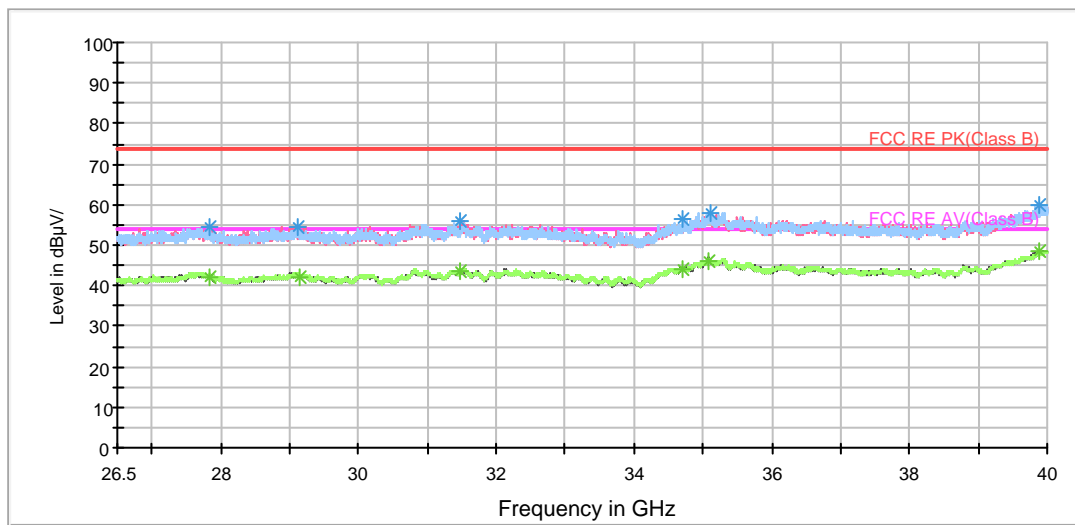

Radiates Emission from 26.5GHz to 40GHz



802.11a CH56

Frequency (MHz)	Peak (dBuV/m)	Height (cm)	Polarization	Azimuth (deg)	Reading value (dBuV/m)	Correct Factor (dB)	Margin (dB)	Limit (dBuV/m)
1231.000000	37.4	100.0	H	0.0	44.9	-7.5	36.6	74
1724.500000	39.7	100.0	V	104.0	45.5	-5.8	34.3	74
2327.500000	41.6	100.0	V	82.0	45.1	-3.5	32.4	74
3613.000000	42.4	100.0	H	156.0	42.1	0.3	31.6	74
5018.500000	45.6	100.0	H	2.0	40.1	5.5	28.4	74
6443.500000	48.1	100.0	V	276.0	38.2	9.9	25.9	74

Remark: 1. Correction Factor = Antenna factor+ Insertion loss (cable loss + amplifier gain)

Frequency (MHz)	Average (dBuV/m)	Height (cm)	Polarization	Azimuth (deg)	Reading value (dBuV/m)	Correct Factor (dB)	Margin (dB)	Limit (dBuV/m)
1231.000000	25.3	100.0	H	0.0	32.8	-7.5	28.7	54
1724.500000	34.3	100.0	V	104.0	40.1	-5.8	19.7	54
2528.500000	29.7	100.0	H	28.0	32.5	-2.8	24.3	54
3644.500000	32.3	100.0	H	0.0	31.9	0.4	21.7	54
5033.500000	34.7	100.0	H	28.0	29.2	5.5	19.3	54
6443.500000	37.0	100.0	V	276.0	27.1	9.9	17.0	54

Remark: 1. Correction Factor = Antenna factor+ Insertion loss (cable loss + amplifier gain)

RE 1G-7GHz PK+AV Class B

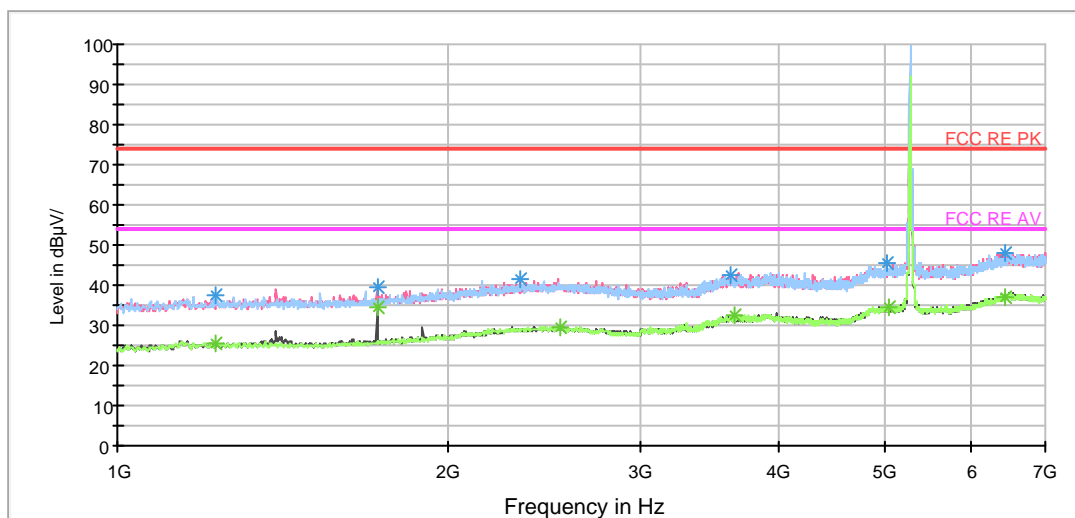

Radiates Emission from 1GHz to 7GHz
Note: The signal beyond the limit is carrier.



RE 3-18GHz PK+AV

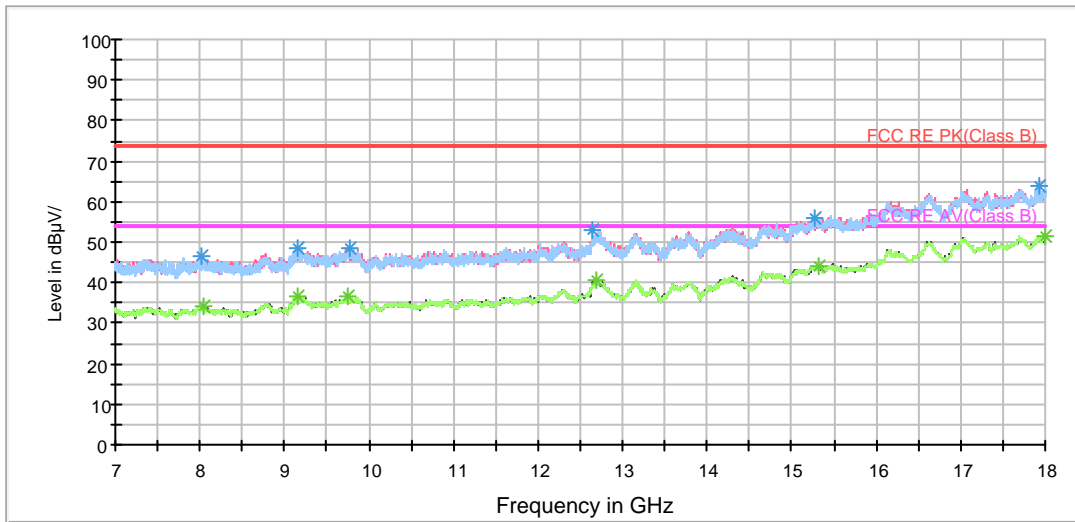

Radiates Emission from 7GHz to 18GHz

RE 18-26.5GHz PK+AV

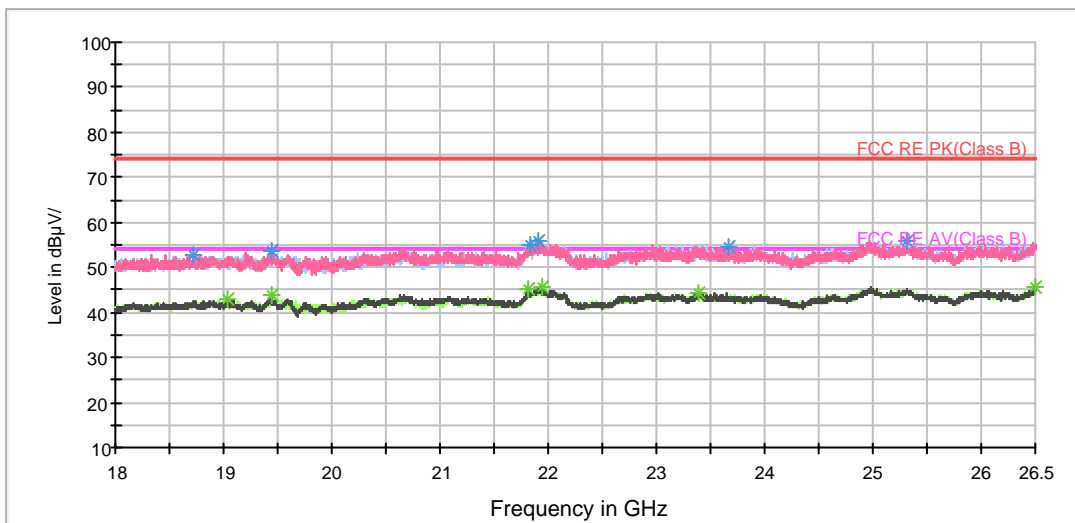

Radiates Emission from 18GHz to 26.5GHz

BELL RE 26.5-40GHz PK+AV

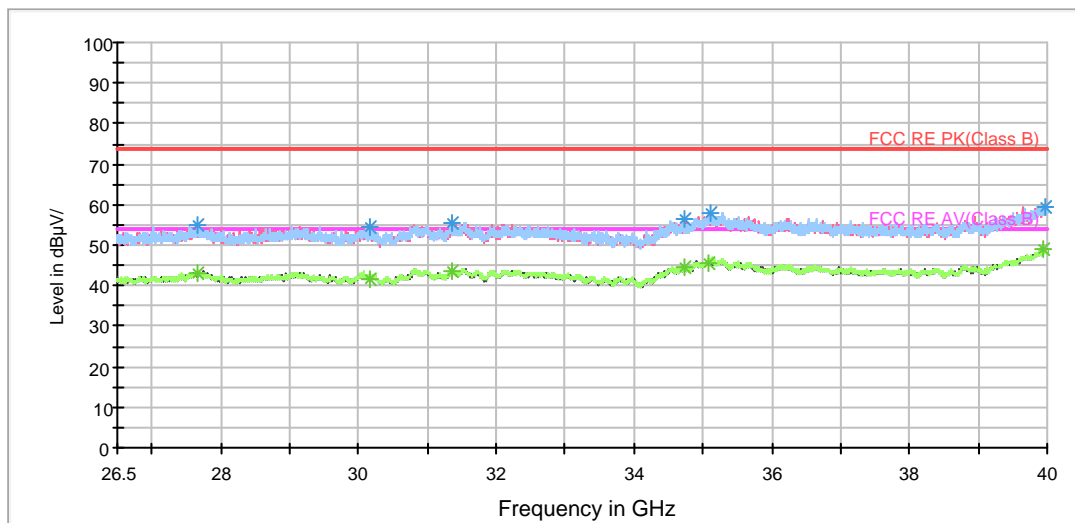

Radiates Emission from 26.5GHz to 40GHz



802.11a CH64

Frequency (MHz)	Peak (dBuV/m)	Height (cm)	Polarization	Azimuth (deg)	Reading value (dBuV/m)	Correct Factor (dB)	Margin (dB)	Limit (dBuV/m)
1198.000000	38.1	100.0	V	0.0	45.7	-7.6	35.9	74
1724.500000	38.9	100.0	V	95.0	44.7	-5.8	35.1	74
2531.500000	41.2	100.0	V	0.0	44.0	-2.8	32.8	74
3580.000000	42.7	100.0	H	1.0	42.6	0.1	31.3	74
5053.000000	45.1	100.0	V	355.0	39.6	5.5	28.9	74
6593.500000	48.4	100.0	V	318.0	38.2	10.2	25.6	74

Remark: 1. Correction Factor = Antenna factor+ Insertion loss (cable loss + amplifier gain)

Frequency (MHz)	Average (dBuV/m)	Height (cm)	Polarization	Azimuth (deg)	Reading value (dBuV/m)	Correct Factor (dB)	Margin (dB)	Limit (dBuV/m)
1198.000000	25.1	100.0	V	0.0	32.7	-7.6	28.9	54
1724.500000	31.7	100.0	V	95.0	37.5	-5.8	22.3	54
2392.000000	29.8	100.0	V	106.0	33.0	-3.2	24.2	54
3640.000000	32.8	100.0	H	10.0	32.4	0.4	21.2	54
5051.500000	34.8	100.0	V	211.0	29.3	5.5	19.2	54
6593.500000	37.2	100.0	V	318.0	27.0	10.2	16.8	54

Remark: 1. Correction Factor = Antenna factor+ Insertion loss (cable loss + amplifier gain)

RE 1G-7GHz PK+AV Class B

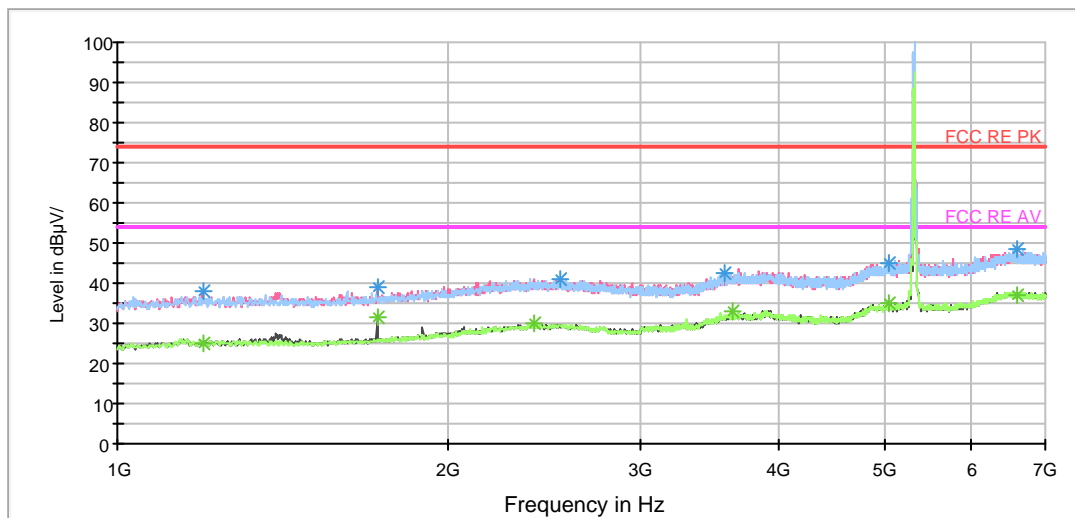

Radiates Emission from 1GHz to 7GHz
Note: The signal beyond the limit is carrier.



RE 3-18GHz PK+AV

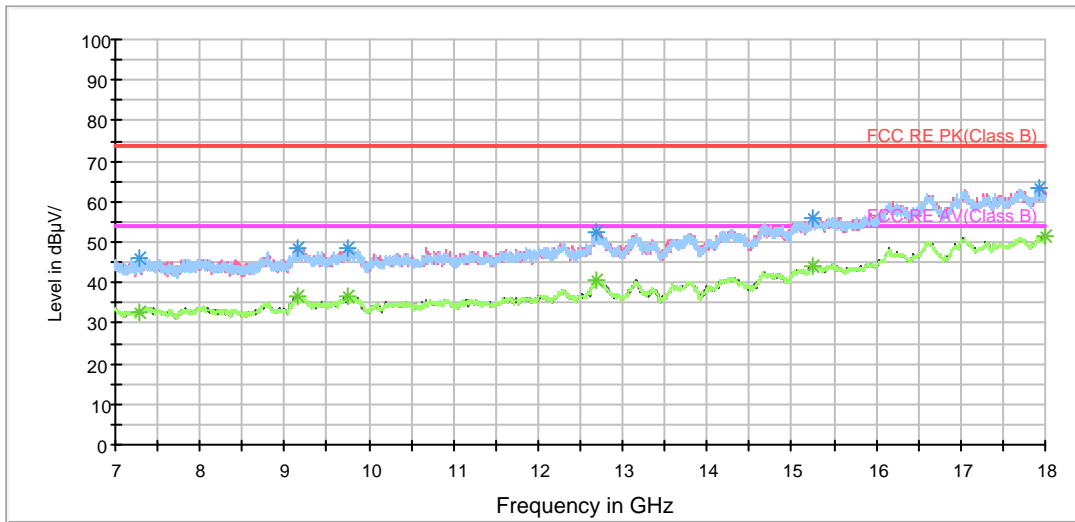

Radiates Emission from 7GHz to 18GHz

RE 18-26.5GHz PK+AV

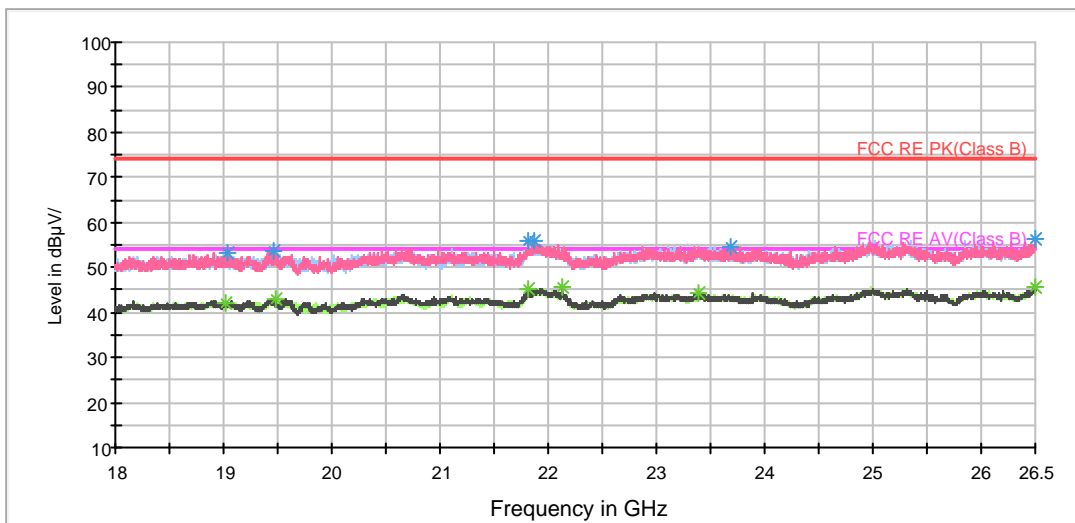

Radiates Emission from 18GHz to 26.5GHz

BELL RE 26.5-40GHz PK+AV

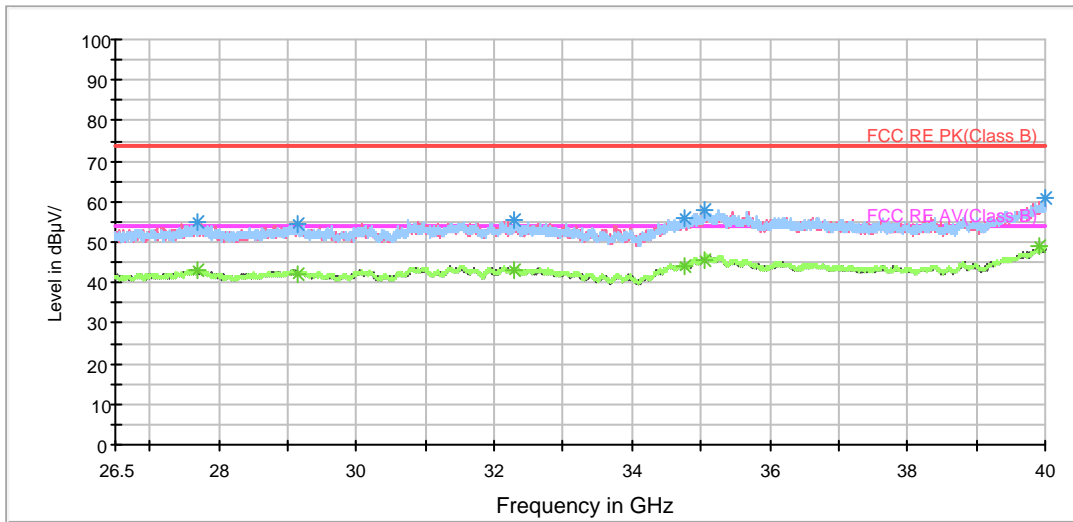

Radiates Emission from 26.5GHz to 40GHz



802.11a CH100

Frequency (MHz)	Peak (dBuV/m)	Height (cm)	Polarization	Azimuth (deg)	Reading value (dBuV/m)	Correct Factor (dB)	Margin (dB)	Limit (dBuV/m)
1220.500000	37.7	100.0	V	183.0	45.2	-7.5	36.3	74
1724.500000	37.8	100.0	V	96.0	43.6	-5.8	36.2	74
2611.000000	41.0	100.0	H	136.0	43.7	-2.7	33.0	74
3613.000000	42.7	100.0	V	354.0	42.4	0.3	31.3	74
4864.000000	44.9	100.0	V	359.0	40.0	4.9	29.1	74
6413.500000	47.9	100.0	V	151.0	38.2	9.7	26.1	74

Remark: 1. Correction Factor = Antenna factor+ Insertion loss (cable loss + amplifier gain)

Frequency (MHz)	Average (dBuV/m)	Height (cm)	Polarization	Azimuth (deg)	Reading value (dBuV/m)	Correct Factor (dB)	Margin (dB)	Limit (dBuV/m)
1220.500000	25.2	100.0	V	183.0	32.7	-7.5	28.8	54
1724.500000	31.9	100.0	V	96.0	37.7	-5.8	22.1	54
2506.000000	30.1	100.0	H	0.0	32.9	-2.8	23.9	54
3641.500000	32.4	100.0	H	147.0	32.0	0.4	21.6	54
5047.000000	34.6	100.0	H	136.0	29.1	5.5	19.4	54
6413.500000	36.2	100.0	V	151.0	26.5	9.7	17.8	54

Remark: 1. Correction Factor = Antenna factor+ Insertion loss (cable loss + amplifier gain)

RE 1G-7GHz PK+AV Class B

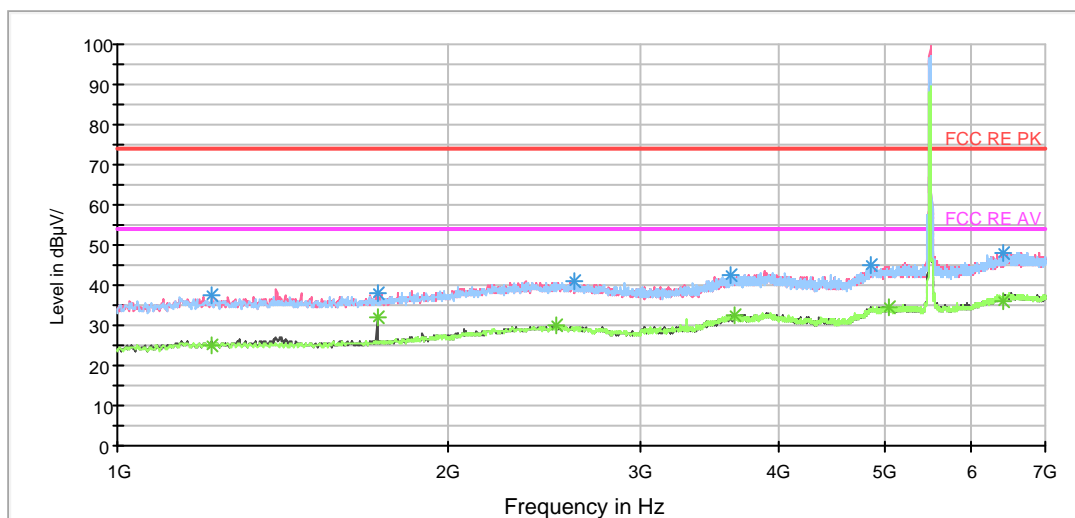

Radiates Emission from 1GHz to 7GHz
 Note: The signal beyond the limit is carrier.

RE 3-18GHz PK+AV

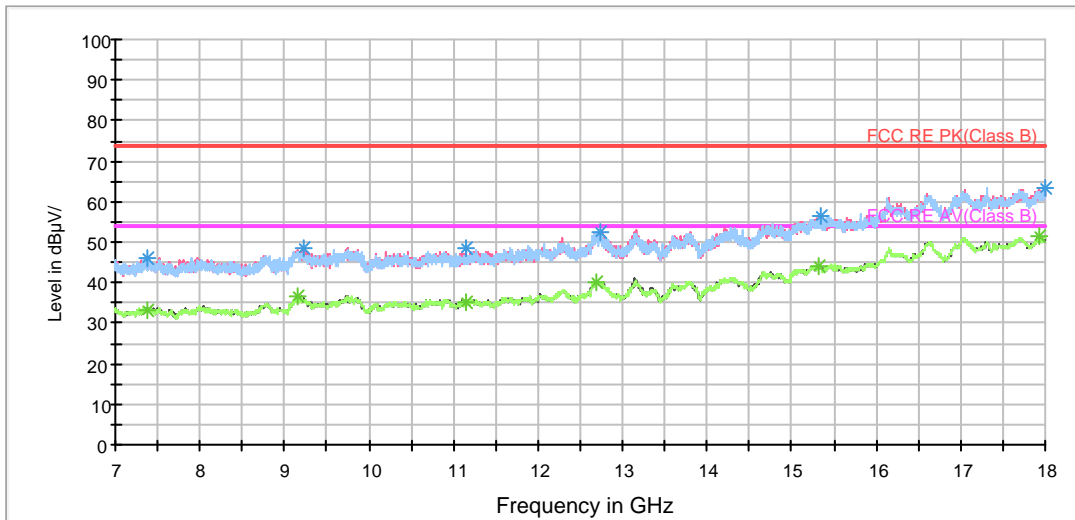

Radiates Emission from 7GHz to 18GHz

RE 18-26.5GHz PK+AV

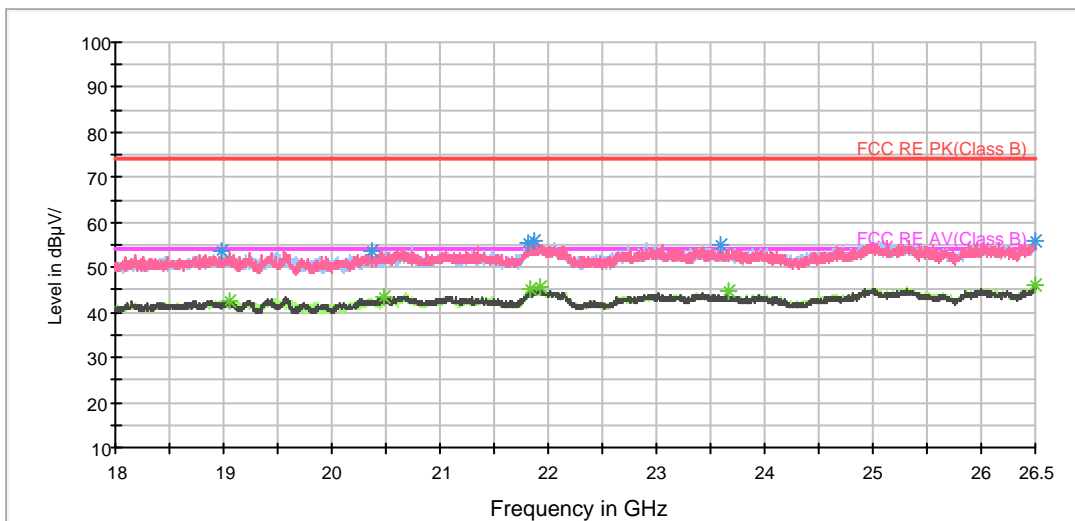

Radiates Emission from 18GHz to 26.5GHz



BELL RE 26.5-40GHz PK+AV

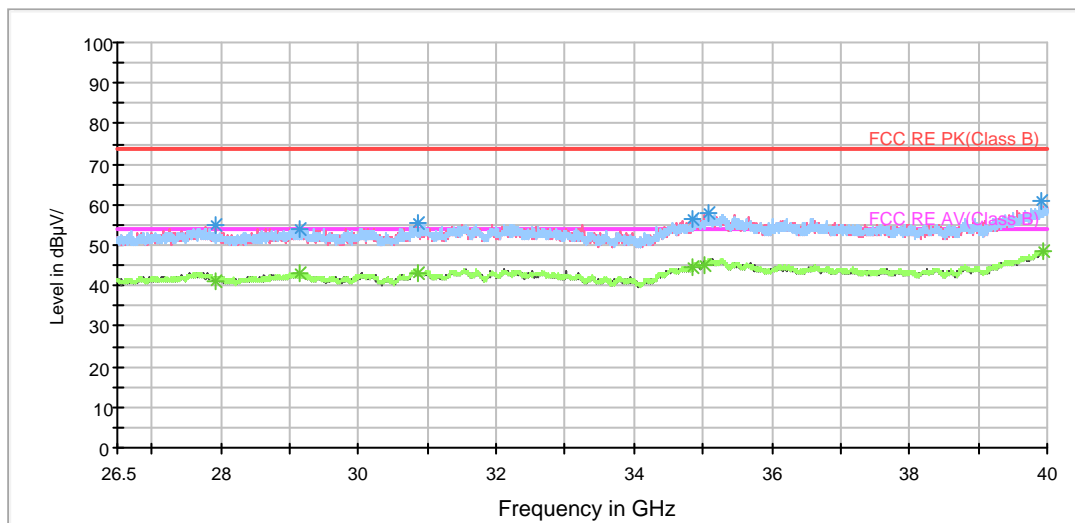

Radiates Emission from 26.5GHz to 40GHz



802.11a CH116

Frequency (MHz)	Peak (dBuV/m)	Height (cm)	Polarization	Azimuth (deg)	Reading value (dBuV/m)	Correct Factor (dB)	Margin (dB)	Limit (dBuV/m)
1232.500000	37.9	100.0	V	245.0	45.4	-7.5	36.1	74
1724.500000	40.0	100.0	V	95.0	45.8	-5.8	34.0	74
2641.000000	41.4	100.0	V	0.0	44.1	-2.7	32.6	74
3613.000000	42.4	100.0	H	71.0	42.1	0.3	31.6	74
4943.500000	45.7	100.0	V	357.0	40.5	5.2	28.3	74
6520.000000	48.2	100.0	V	277.0	38.0	10.2	25.8	74

Remark: 1. Correction Factor = Antenna factor+ Insertion loss (cable loss + amplifier gain)

Frequency (MHz)	Average (dBuV/m)	Height (cm)	Polarization	Azimuth (deg)	Reading value (dBuV/m)	Correct Factor (dB)	Margin (dB)	Limit (dBuV/m)
1232.500000	25.4	100.0	V	245.0	32.9	-7.5	28.6	54
1724.500000	35.4	100.0	V	95.0	41.2	-5.8	18.6	54
2521.000000	30.0	100.0	V	0.0	32.8	-2.8	24.0	54
3613.000000	32.5	100.0	V	354.0	32.2	0.3	21.5	54
5057.500000	35.2	100.0	V	277.0	29.7	5.5	18.8	54
6520.000000	36.8	100.0	V	277.0	26.6	10.2	17.2	54

Remark: 1. Correction Factor = Antenna factor+ Insertion loss (cable loss + amplifier gain)

RE 1G-7GHz PK+AV Class B

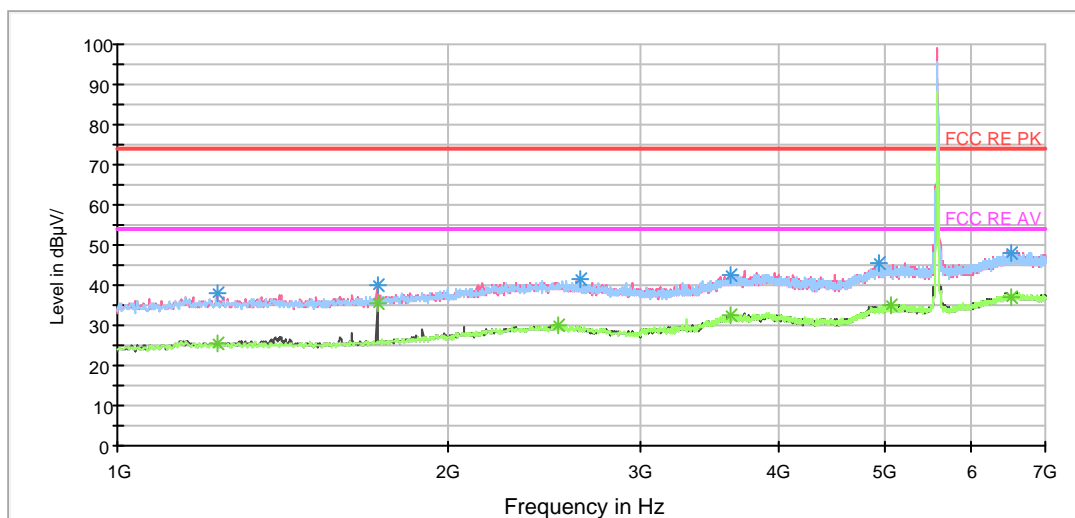

Radiates Emission from 1GHz to 7GHz
Note: The signal beyond the limit is carrier.

RE 3-18GHz PK+AV

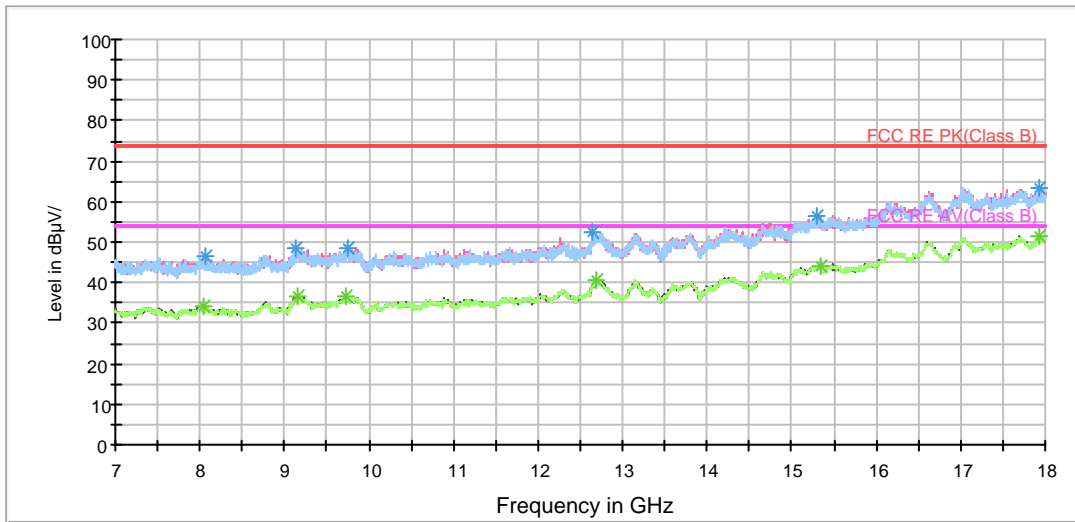

Radiates Emission from 7GHz to 18GHz

RE 18-26.5GHz PK+AV

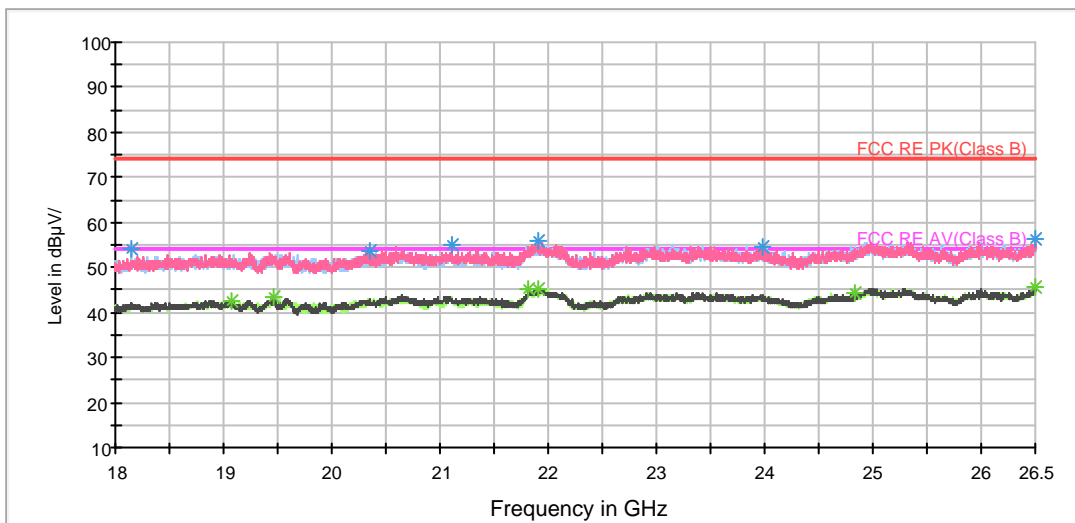

Radiates Emission from 18GHz to 26.5GHz

BELL RE 26.5-40GHz PK+AV

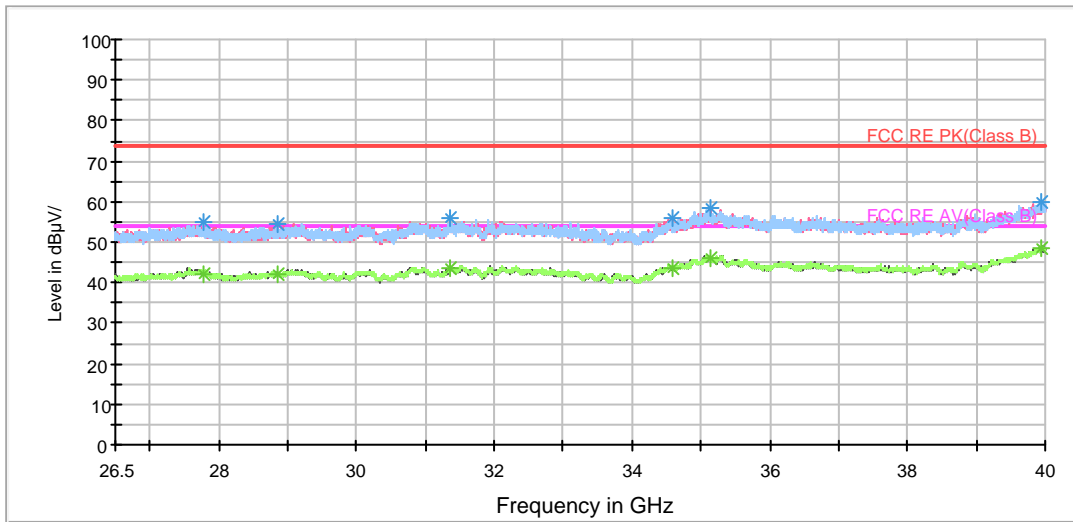

Radiates Emission from 26.5GHz to 40GHz



802.11a CH140

Frequency (MHz)	Peak (dBuV/m)	Height (cm)	Polarization	Azimuth (deg)	Reading value (dBuV/m)	Correct Factor (dB)	Margin (dB)	Limit (dBuV/m)
1397.500000	41.1	100.0	V	15.0	48.0	-6.9	32.9	74
1724.500000	39.1	100.0	V	104.0	44.9	-5.8	34.9	74
2621.500000	41.9	100.0	H	102.0	44.6	-2.7	32.1	74
3635.500000	42.7	100.0	H	0.0	42.4	0.3	31.3	74
5029.000000	45.4	100.0	V	353.0	39.9	5.5	28.6	74
6533.500000	48.6	100.0	V	71.0	38.4	10.2	25.4	74

Remark: 1. Correction Factor = Antenna factor+ Insertion loss (cable loss + amplifier gain)

Frequency (MHz)	Average (dBuV/m)	Height (cm)	Polarization	Azimuth (deg)	Reading value (dBuV/m)	Correct Factor (dB)	Margin (dB)	Limit (dBuV/m)
1379.500000	26.3	100.0	V	307.0	33.3	-7.0	27.7	54
1724.500000	33.2	100.0	V	104.0	39.0	-5.8	20.8	54
2621.500000	29.2	100.0	H	102.0	31.9	-2.7	24.8	54
3614.500000	32.4	100.0	V	0.0	32.1	0.3	21.6	54
4858.000000	34.9	100.0	V	244.0	30.0	4.9	19.1	54
6533.500000	37.1	100.0	V	71.0	26.9	10.2	16.9	54

Remark: 1. Correction Factor = Antenna factor+ Insertion loss (cable loss + amplifier gain)

RE 1G-7GHz PK+AV Class B

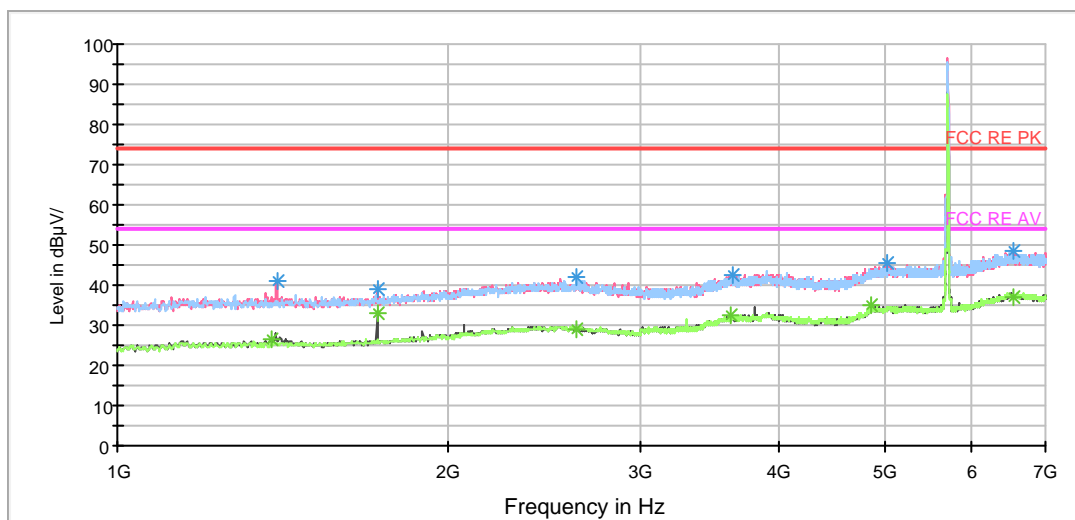

Radiates Emission from 1GHz to 7GHz
 Note: The signal beyond the limit is carrier.



RE 3-18GHz PK+AV

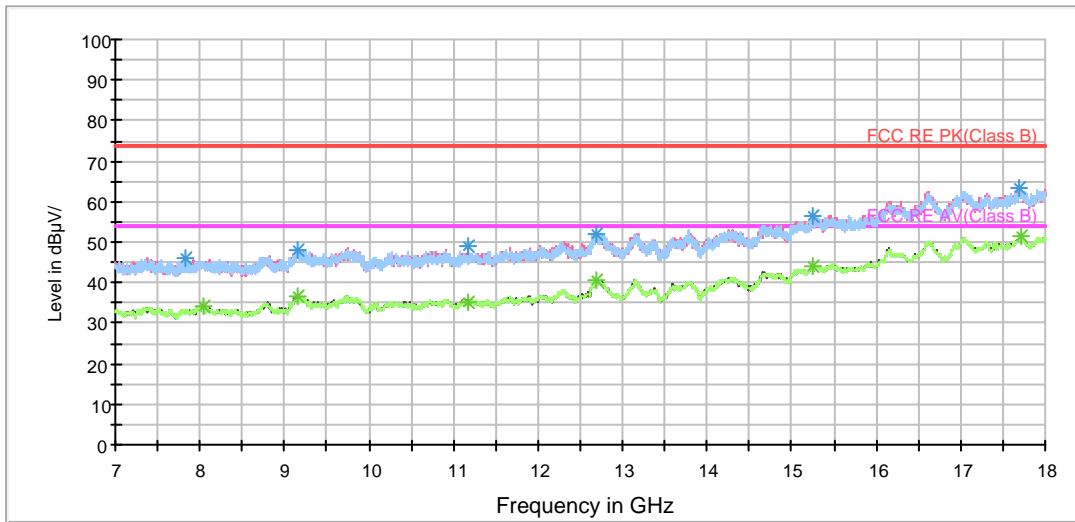

Radiates Emission from 7GHz to 18GHz

RE 18-26.5GHz PK+AV

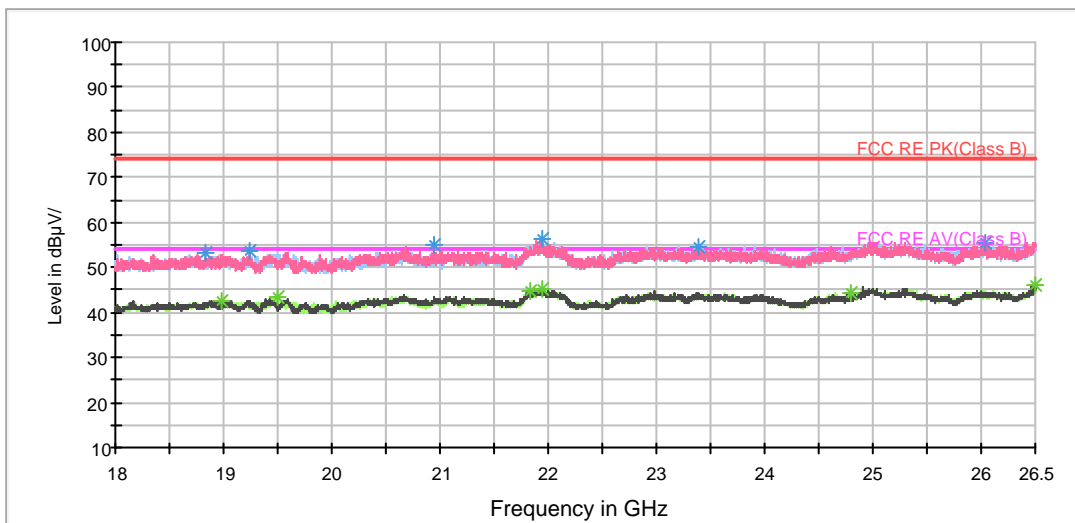

Radiates Emission from 18GHz to 26.5GHz

BELL RE 26.5-40GHz PK+AV

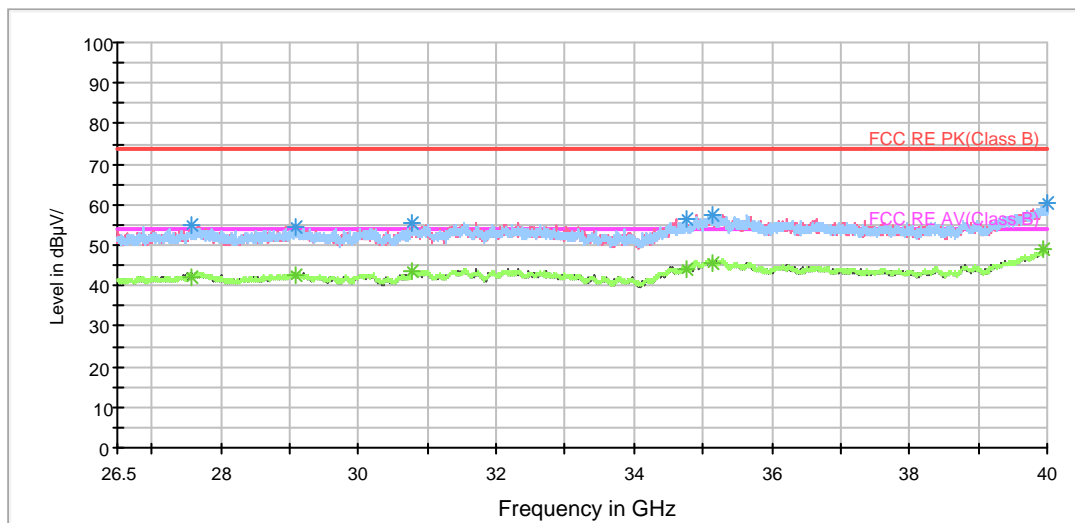

Radiates Emission from 26.5GHz to 40GHz



802.11a CH149

Frequency (MHz)	Peak (dBuV/m)	Height (cm)	Polarization	Azimuth (deg)	Reading value (dBuV/m)	Correct Factor (dB)	Margin (dB)	Limit (dBuV/m)
1187.500000	37.7	100.0	H	15.0	45.3	-7.6	36.3	74
1724.500000	39.5	100.0	V	107.0	45.3	-5.8	34.5	74
2636.500000	41.3	100.0	V	204.0	44.0	-2.7	32.7	74
3568.000000	42.5	100.0	V	359.0	42.4	0.1	31.5	74
5027.500000	45.4	100.0	V	0.0	39.9	5.5	28.6	74
6475.000000	48.7	100.0	V	107.0	38.6	10.1	25.3	74

Remark: 1. Correction Factor = Antenna factor+ Insertion loss (cable loss + amplifier gain)

Frequency (MHz)	Average (dBuV/m)	Height (cm)	Polarization	Azimuth (deg)	Reading value (dBuV/m)	Correct Factor (dB)	Margin (dB)	Limit (dBuV/m)
1187.500000	25.3	100.0	H	15.0	32.9	-7.6	28.7	54
1724.500000	33.2	100.0	V	107.0	39.0	-5.8	20.8	54
2509.000000	29.9	100.0	H	15.0	32.7	-2.8	24.1	54
3634.000000	32.5	100.0	V	0.0	32.2	0.3	21.5	54
5053.000000	35.2	100.0	H	41.0	29.7	5.5	18.8	54
6475.000000	37.2	100.0	V	107.0	27.1	10.1	16.8	54

Remark: 1. Correction Factor = Antenna factor+ Insertion loss (cable loss + amplifier gain)

RE 1G-7GHz PK+AV Class B

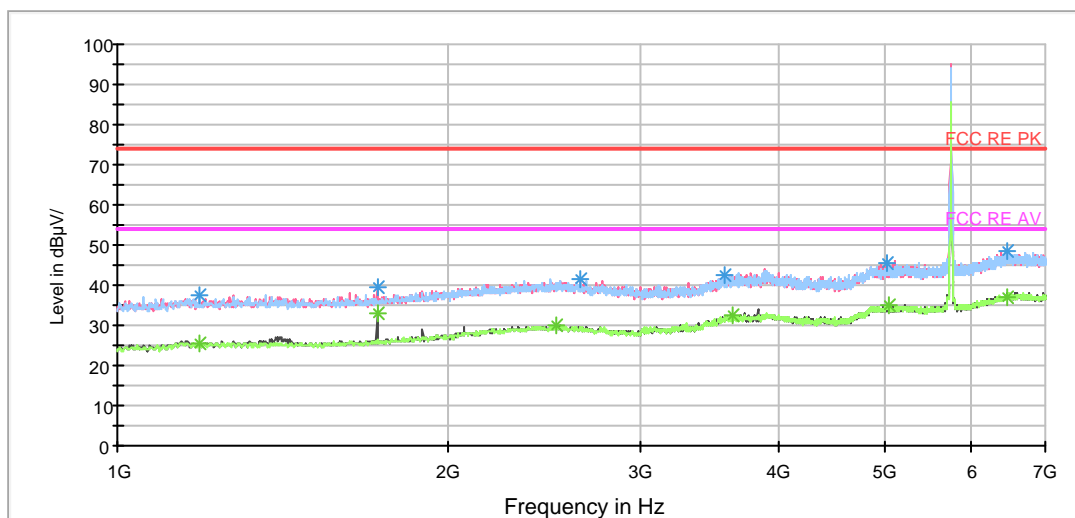

Radiates Emission from 1GHz to 7GHz
Note: The signal beyond the limit is carrier.

RE 3-18GHz PK+AV

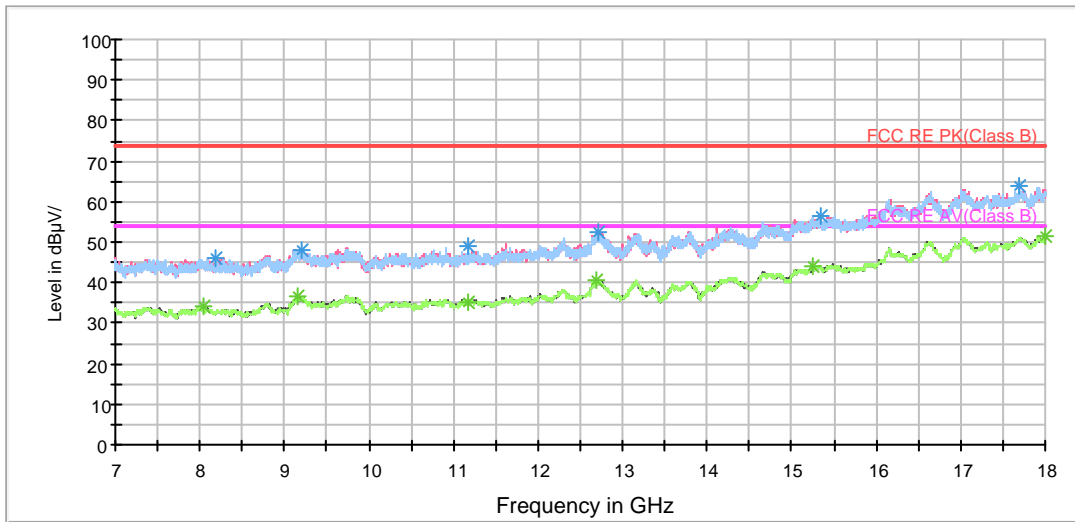

Radiates Emission from 7GHz to 18GHz

RE 18-26.5GHz PK+AV

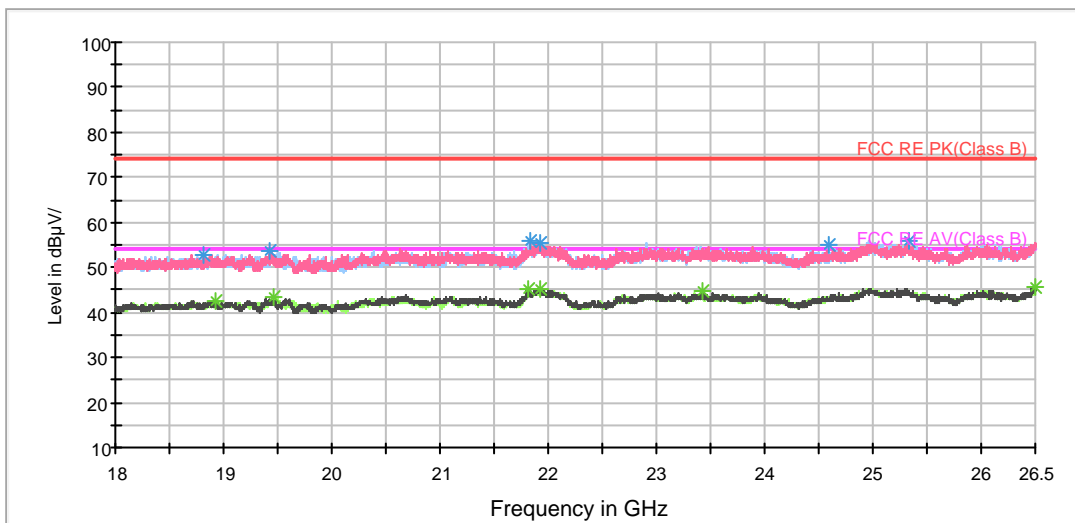

Radiates Emission from 18GHz to 26.5GHz



BELL RE 26.5-40GHz PK+AV

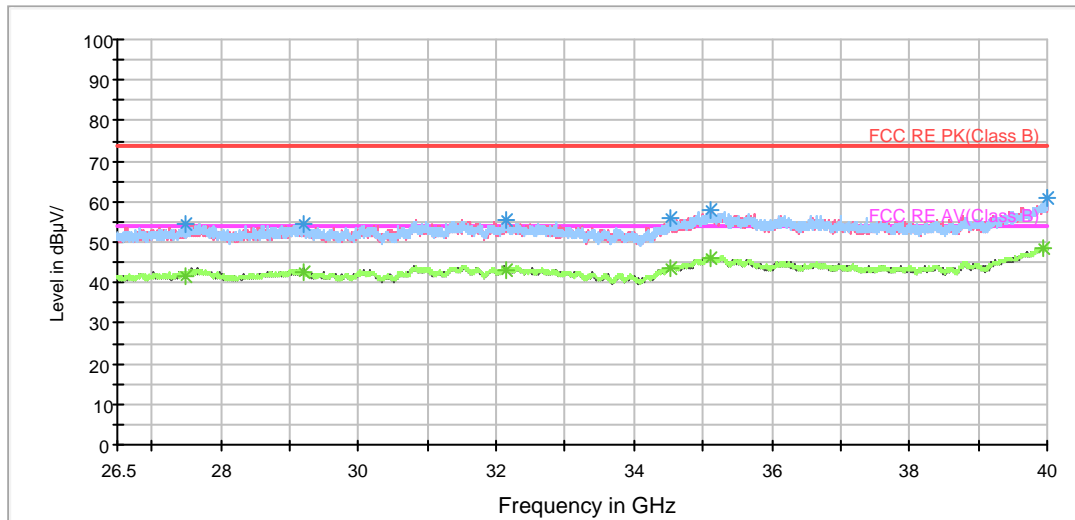

Radiates Emission from 26.5GHz to 40GHz



802.11a CH157

Frequency (MHz)	Peak (dBuV/m)	Height (cm)	Polarization	Azimuth (deg)	Reading value (dBuV/m)	Correct Factor (dB)	Margin (dB)	Limit (dBuV/m)
1159.000000	37.7	100.0	V	0.0	45.4	-7.7	36.3	74
1724.500000	41.7	100.0	V	106.0	47.5	-5.8	32.3	74
2543.500000	41.2	100.0	V	0.0	44.0	-2.8	32.8	74
3571.000000	43.2	100.0	H	266.0	43.1	0.1	30.8	74
5032.000000	45.1	100.0	V	357.0	39.6	5.5	28.9	74
6445.000000	47.9	100.0	H	51.0	38.0	9.9	26.1	74

Remark: 1. Correction Factor = Antenna factor+ Insertion loss (cable loss + amplifier gain)

Frequency (MHz)	Average (dBuV/m)	Height (cm)	Polarization	Azimuth (deg)	Reading value (dBuV/m)	Correct Factor (dB)	Margin (dB)	Limit (dBuV/m)
1159.000000	25.7	100.0	V	0.0	33.4	-7.7	28.3	54
1724.500000	34.6	100.0	V	106.0	40.4	-5.8	19.4	54
2543.500000	29.3	100.0	V	0.0	32.1	-2.8	24.7	54
3634.000000	32.7	100.0	V	359.0	32.4	0.3	21.3	54
5047.000000	34.8	100.0	H	0.0	29.3	5.5	19.2	54
6445.000000	37.1	100.0	H	51.0	27.2	9.9	16.9	54

Remark: 1. Correction Factor = Antenna factor+ Insertion loss (cable loss + amplifier gain)

RE 1G-7GHz PK+AV Class B

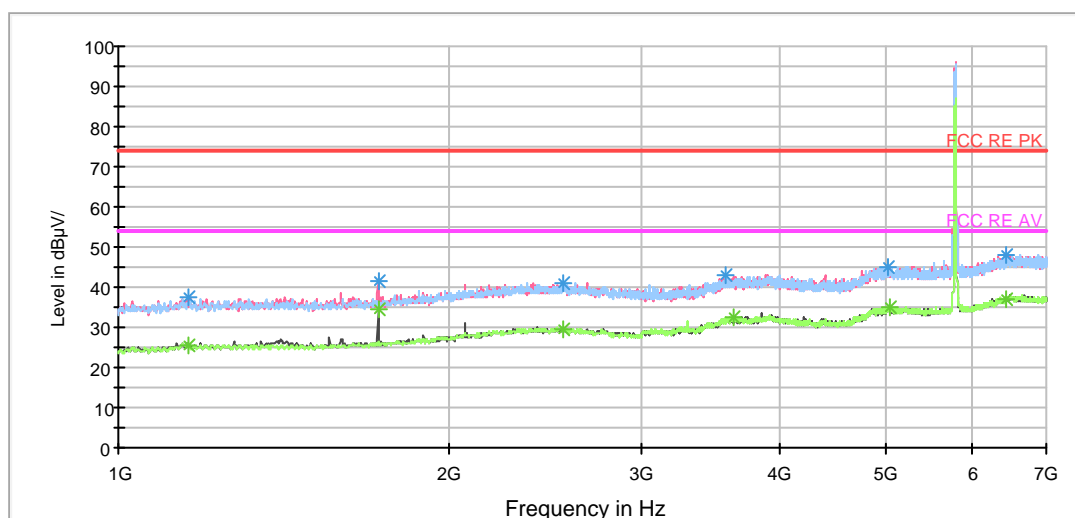

Radiates Emission from 1GHz to 7GHz
Note: The signal beyond the limit is carrier.

RE 3-18GHz PK+AV

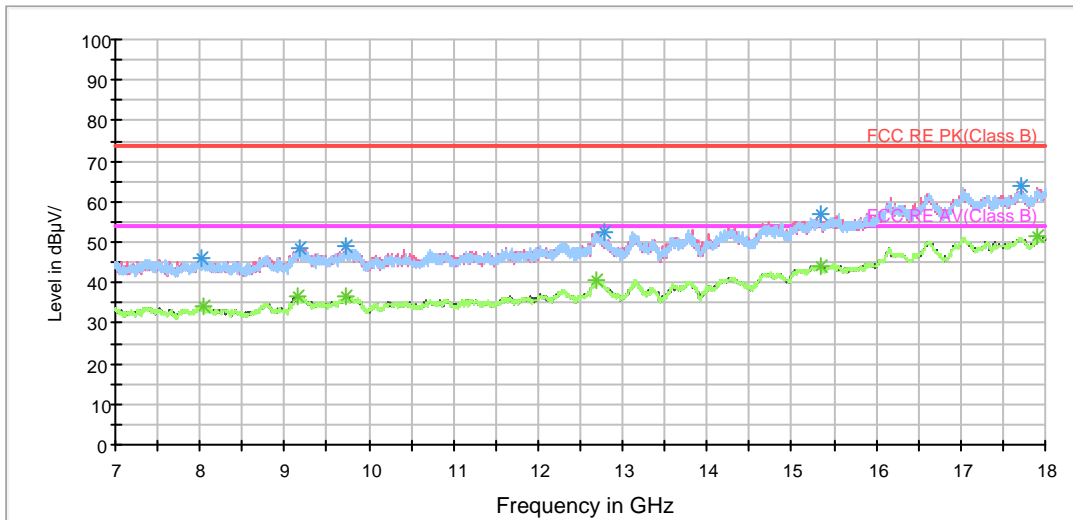

Radiates Emission from 7GHz to 18GHz

RE 18-26.5GHz PK+AV

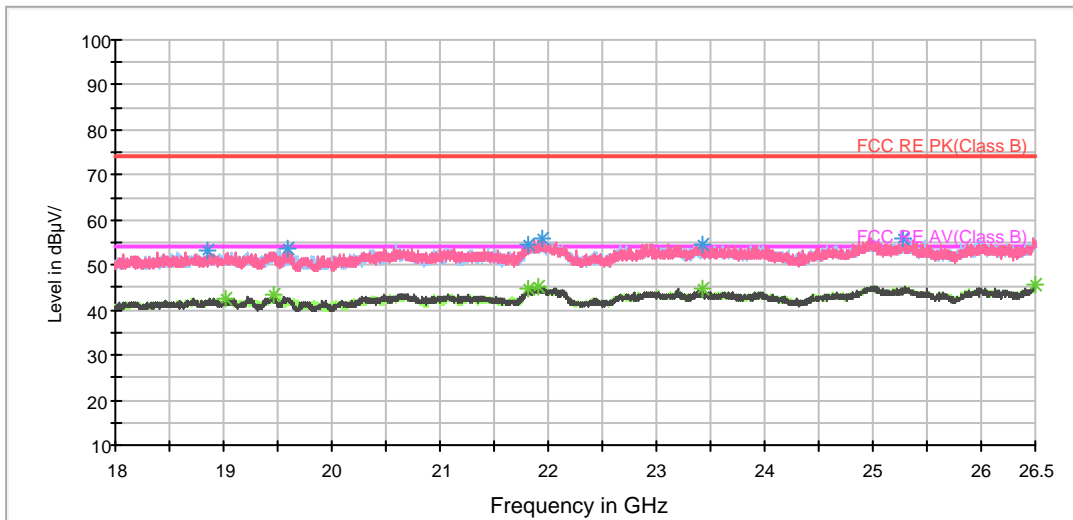

Radiates Emission from 18GHz to 26.5GHz

BELL RE 26.5-40GHz PK+AV

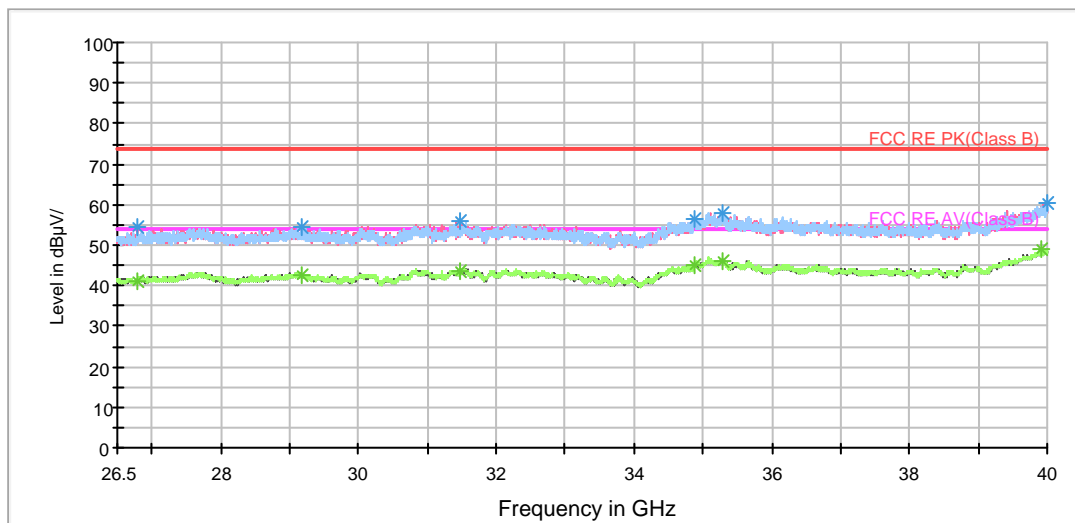

Radiates Emission from 26.5GHz to 40GHz



802.11a CH165

Frequency (MHz)	Peak (dBuV/m)	Height (cm)	Polarization	Azimuth (deg)	Reading value (dBuV/m)	Correct Factor (dB)	Margin (dB)	Limit (dBuV/m)
1363.000000	38.4	100.0	V	0.0	45.5	-7.1	35.6	74
1724.500000	38.7	100.0	V	139.0	44.5	-5.8	35.3	74
2489.500000	41.4	100.0	V	310.0	44.3	-2.9	32.6	74
3646.000000	42.7	100.0	H	0.0	42.3	0.4	31.3	74
4922.500000	45.0	100.0	H	92.0	39.9	5.1	29.0	74
6583.000000	48.3	100.0	H	146.0	38.1	10.2	25.7	74

Remark: 1. Correction Factor = Antenna factor+ Insertion loss (cable loss + amplifier gain)

Frequency (MHz)	Average (dBuV/m)	Height (cm)	Polarization	Azimuth (deg)	Reading value (dBuV/m)	Correct Factor (dB)	Margin (dB)	Limit (dBuV/m)
1363.000000	26.4	100.0	V	0.0	33.5	-7.1	27.6	54
1724.500000	30.4	100.0	V	139.0	36.2	-5.8	23.6	54
2503.000000	29.8	100.0	H	30.0	32.6	-2.8	24.2	54
3640.000000	32.6	100.0	H	4.0	32.2	0.4	21.4	54
3883.000000	35.1	100.0	V	300.0	33.7	1.4	18.9	54
6583.000000	37.3	100.0	H	146.0	27.1	10.2	16.7	54

Remark: 1. Correction Factor = Antenna factor+ Insertion loss (cable loss + amplifier gain)

RE 1G-7GHz PK+AV Class B

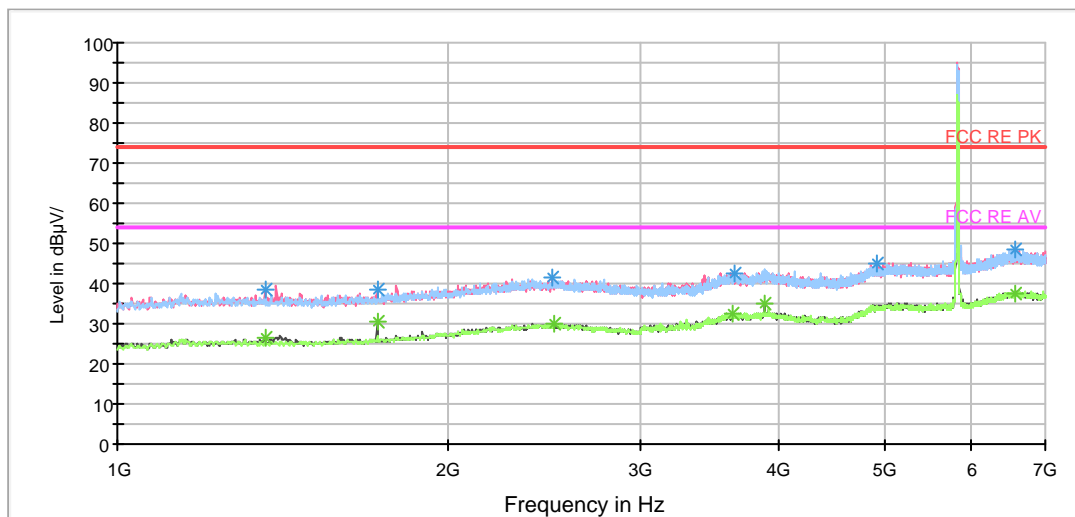

Radiates Emission from 1GHz to 7GHz
Note: The signal beyond the limit is carrier.

RE 3-18GHz PK+AV

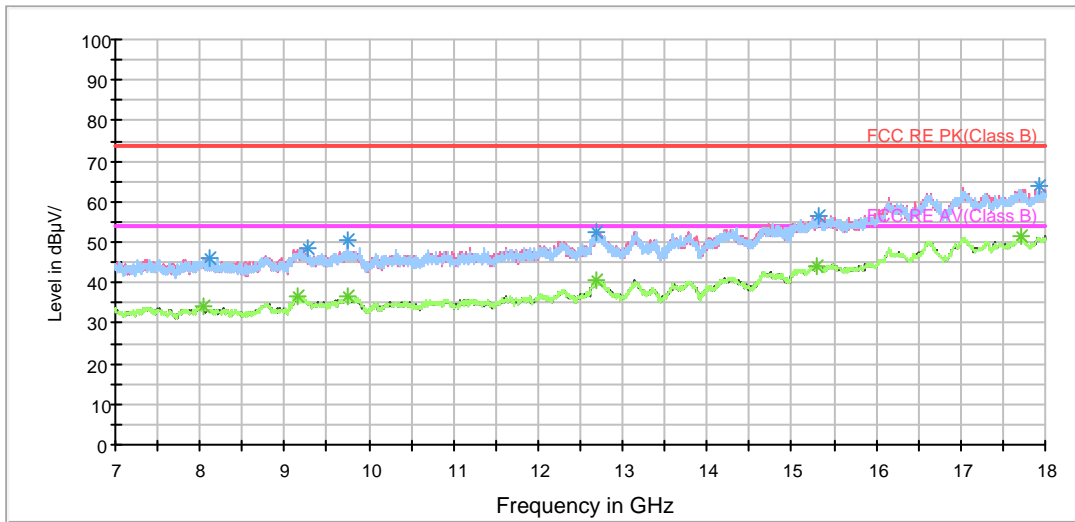

Radiates Emission from 7GHz to 18GHz

RE 18-26.5GHz PK+AV

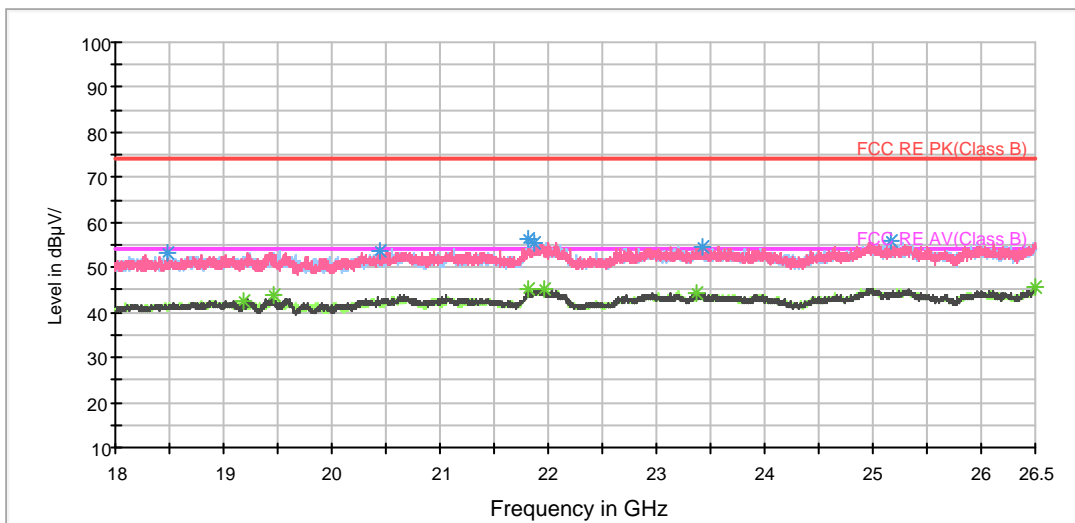

Radiates Emission from 18GHz to 26.5GHz



BELL RE 26.5-40GHz PK+AV

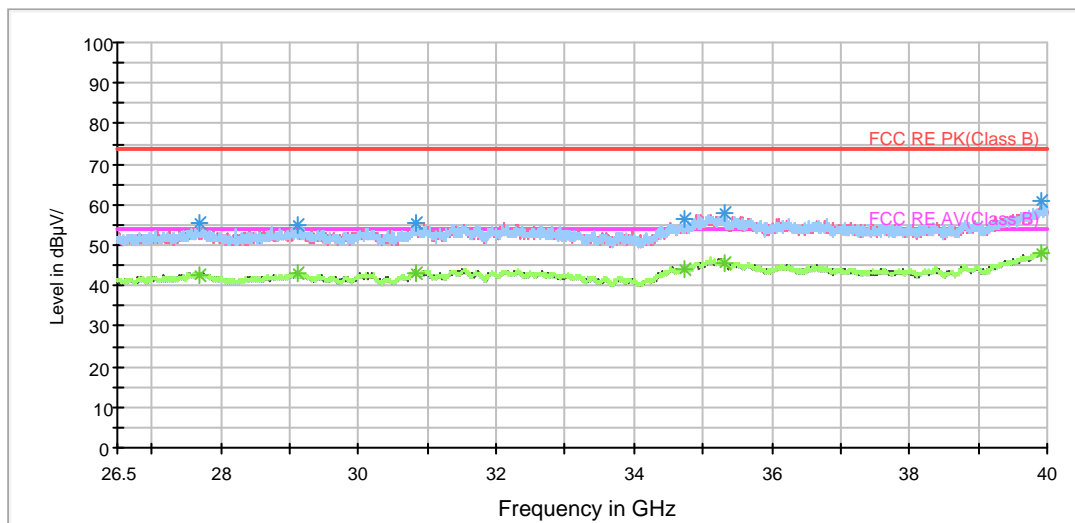

Radiates Emission from 26.5GHz to 40GHz



802.11n (HT20) CH36

Frequency (MHz)	Peak (dBuV/m)	Height (cm)	Polarization	Azimuth (deg)	Reading value (dBuV/m)	Correct Factor (dB)	Margin (dB)	Limit (dBuV/m)
1207.000000	37.0	100.0	V	0.0	44.5	-7.5	37.0	74
1724.500000	38.6	100.0	V	106.0	44.4	-5.8	35.4	74
2504.500000	40.4	100.0	H	72.0	43.2	-2.8	33.6	74
3614.500000	42.6	100.0	H	62.0	42.3	0.3	31.4	74
4976.500000	45.2	100.0	V	0.0	39.9	5.3	28.8	74
6410.500000	48.0	100.0	V	359.0	38.3	9.7	26.0	74

Remark: 1. Correction Factor = Antenna factor+ Insertion loss (cable loss + amplifier gain)

Frequency (MHz)	Average (dBuV/m)	Height (cm)	Polarization	Azimuth (deg)	Reading value (dBuV/m)	Correct Factor (dB)	Margin (dB)	Limit (dBuV/m)
1207.000000	25.0	100.0	V	0.0	32.5	-7.5	29.0	54
1724.500000	33.1	100.0	V	106.0	38.9	-5.8	20.9	54
2504.500000	30.0	100.0	H	72.0	32.8	-2.8	24.0	54
3641.500000	32.6	100.0	V	0.0	32.2	0.4	21.4	54
5033.500000	34.8	100.0	V	236.0	29.3	5.5	19.2	54
6410.500000	36.6	100.0	V	359.0	26.9	9.7	17.4	54

Remark: 1. Correction Factor = Antenna factor+ Insertion loss (cable loss + amplifier gain)

RE 1G-7GHz PK+AV Class B

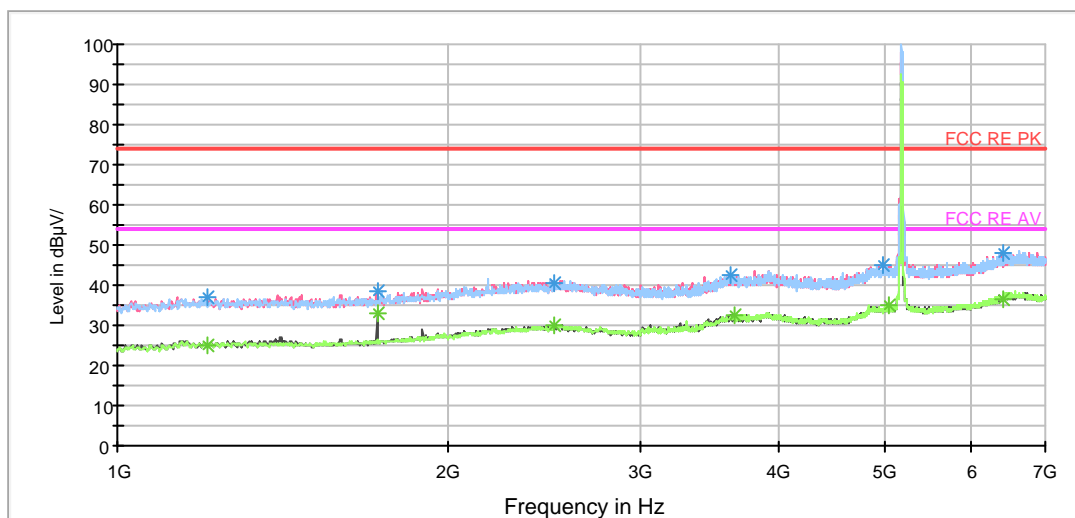

Radiates Emission from 1GHz to 7GHz

Note: The signal beyond the limit is carrier.



RE 3-18GHz PK+AV

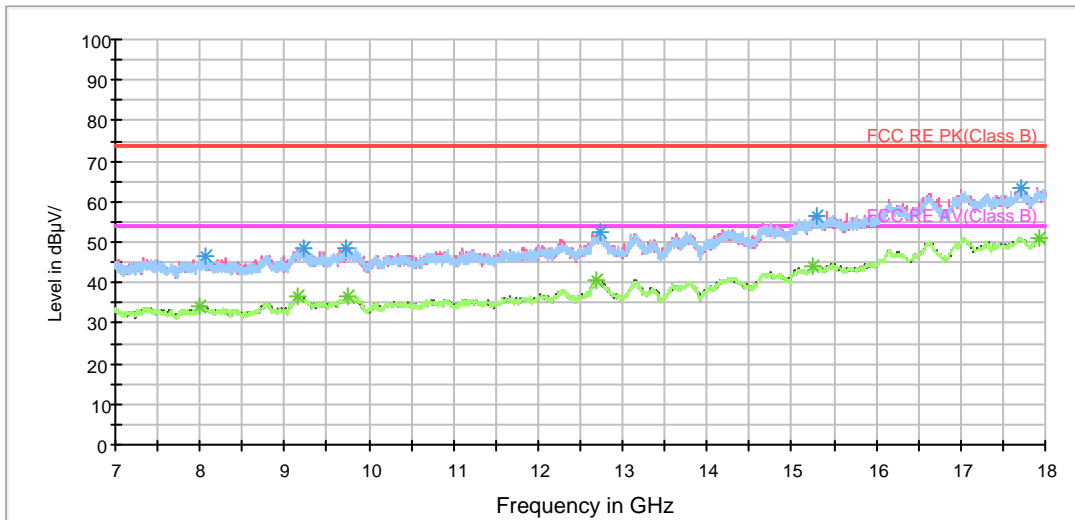

Radiates Emission from 7GHz to 18GHz

RE 18-26.5GHz PK+AV

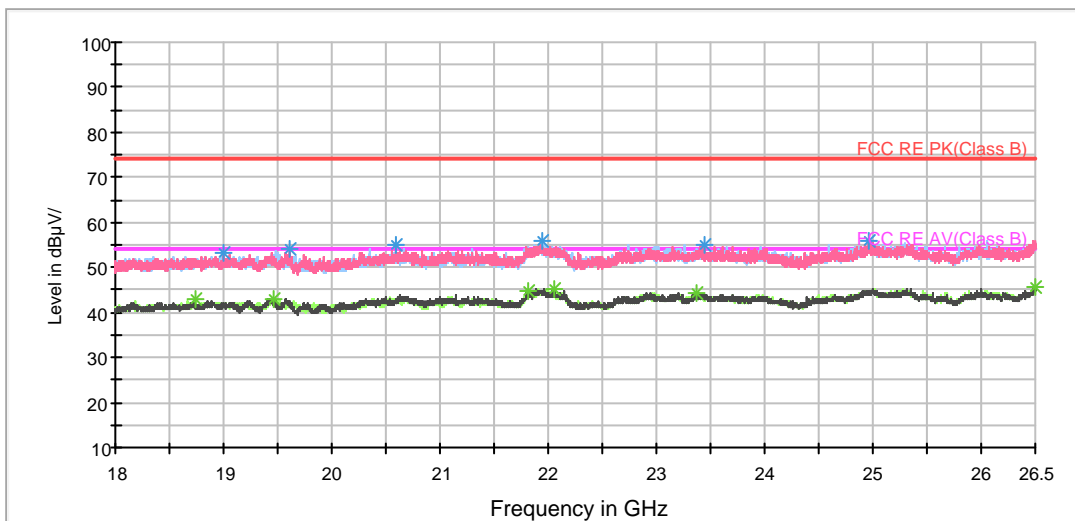

Radiates Emission from 18GHz to 26.5GHz

BELL RE 26.5-40GHz PK+AV

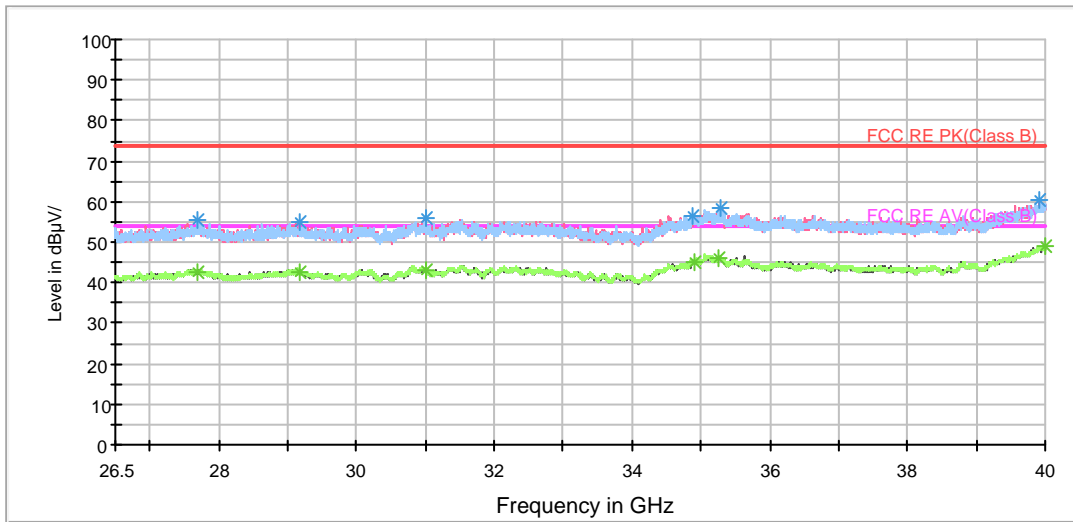

Radiates Emission from 26.5GHz to 40GHz



802.11n (HT20) CH40

Frequency (MHz)	Peak (dBuV/m)	Height (cm)	Polarization	Azimuth (deg)	Reading value (dBuV/m)	Correct Factor (dB)	Margin (dB)	Limit (dBuV/m)
1399.000000	42.1	100.0	V	0.0	49.0	-6.9	31.9	74
1724.500000	40.3	100.0	V	129.0	46.1	-5.8	33.7	74
2390.500000	41.3	100.0	V	107.0	44.5	-3.2	32.7	74
3598.000000	42.7	100.0	V	144.0	42.5	0.2	31.3	74
5023.000000	45.6	100.0	V	52.0	40.1	5.5	28.4	74
6712.000000	48.7	100.0	V	167.0	38.5	10.2	25.3	74

Remark: 1. Correction Factor = Antenna factor+ Insertion loss (cable loss + amplifier gain)

Frequency (MHz)	Average (dBuV/m)	Height (cm)	Polarization	Azimuth (deg)	Reading value (dBuV/m)	Correct Factor (dB)	Margin (dB)	Limit (dBuV/m)
1379.500000	26.5	100.0	V	144.0	33.5	-7.0	27.5	54
1724.500000	32.6	100.0	V	129.0	38.4	-5.8	21.4	54
2533.000000	30.0	100.0	V	291.0	32.8	-2.8	24.0	54
3617.500000	32.6	100.0	V	167.0	32.3	0.3	21.4	54
5011.000000	34.8	100.0	H	77.0	29.4	5.4	19.2	54
6712.000000	37.1	100.0	V	167.0	26.9	10.2	16.9	54

Remark: 1. Correction Factor = Antenna factor+ Insertion loss (cable loss + amplifier gain)

RE 1G-7GHz PK+AV Class B

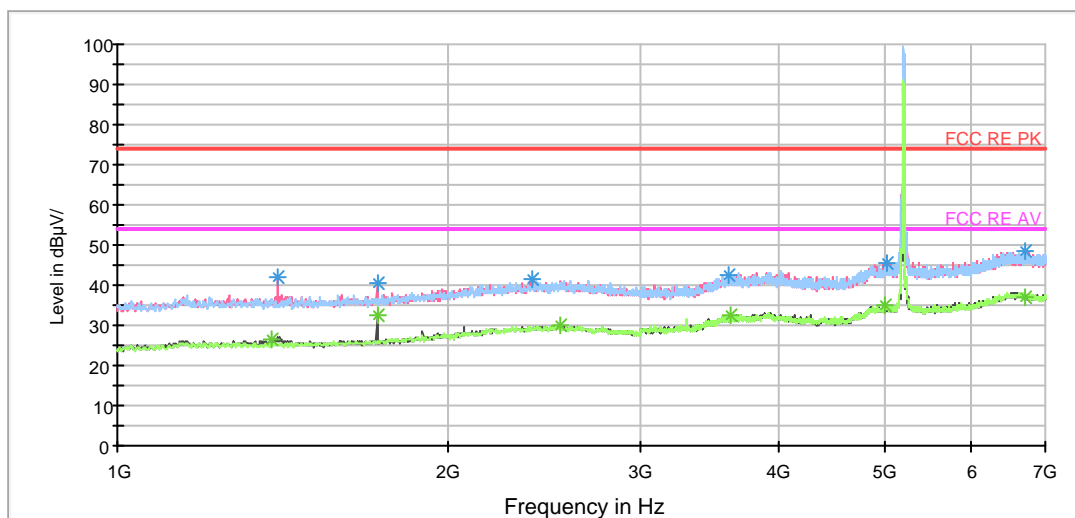

Radiates Emission from 1GHz to 7GHz
Note: The signal beyond the limit is carrier.

RE 3-18GHz PK+AV

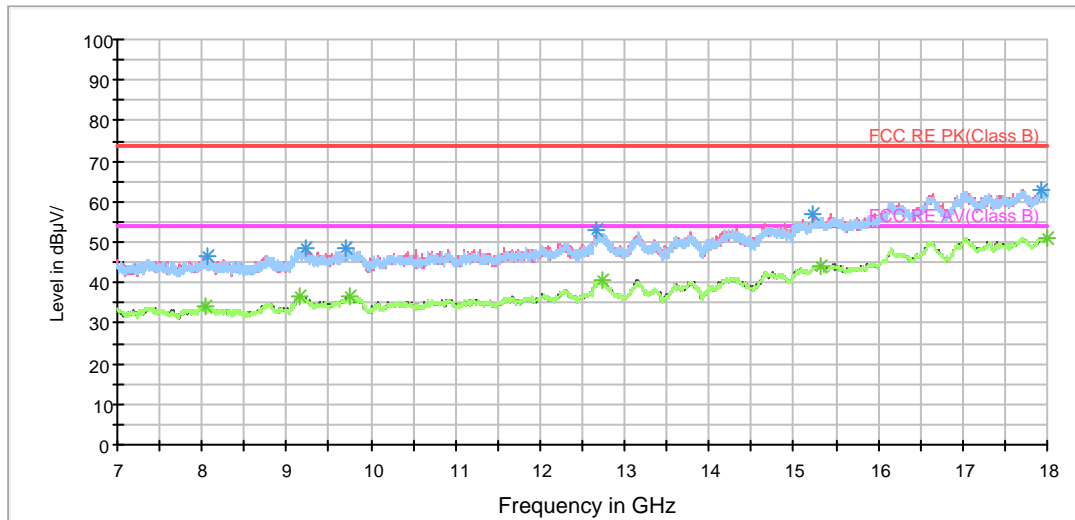

Radiates Emission from 7GHz to 18GHz

RE 18-26.5GHz PK+AV

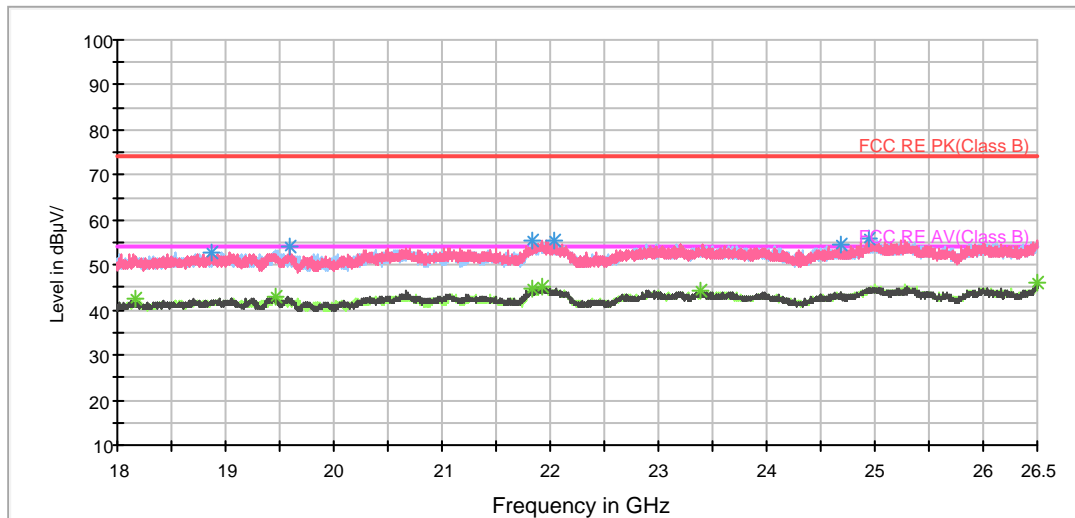

Radiates Emission from 18GHz to 26.5GHz

BELL RE 26.5-40GHz PK+AV

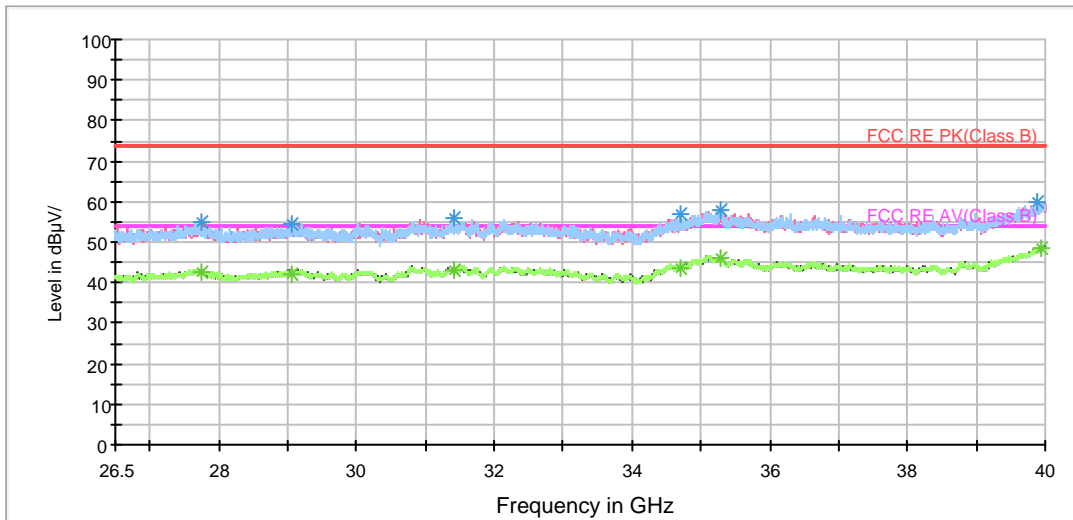

Radiates Emission from 26.5GHz to 40GHz



802.11n (HT20) CH48

Frequency (MHz)	Peak (dBuV/m)	Height (cm)	Polarization	Azimuth (deg)	Reading value (dBuV/m)	Correct Factor (dB)	Margin (dB)	Limit (dBuV/m)
1400.500000	41.1	100.0	V	182.0	48.0	-6.9	32.9	74
1724.500000	37.9	100.0	V	350.0	43.7	-5.8	36.1	74
2597.500000	41.4	100.0	H	49.0	44.2	-2.8	32.6	74
3448.000000	42.5	100.0	H	30.0	43.0	-0.5	31.5	74
5045.500000	45.2	100.0	V	356.0	39.7	5.5	28.8	74
6584.500000	48.4	100.0	H	0.0	38.2	10.2	25.6	74

Remark: 1. Correction Factor = Antenna factor+ Insertion loss (cable loss + amplifier gain)

Frequency (MHz)	Average (dBuV/m)	Height (cm)	Polarization	Azimuth (deg)	Reading value (dBuV/m)	Correct Factor (dB)	Margin (dB)	Limit (dBuV/m)
1400.500000	26.2	100.0	V	182.0	33.1	-6.9	27.8	54
1724.500000	30.9	100.0	V	350.0	36.7	-5.8	23.1	54
2503.000000	29.9	100.0	H	253.0	32.7	-2.8	24.1	54
3614.500000	32.6	100.0	V	235.0	32.3	0.3	21.4	54
5033.500000	34.9	100.0	H	134.0	29.4	5.5	19.1	54
6584.500000	37.1	100.0	H	0.0	26.9	10.2	16.9	54

Remark: 1. Correction Factor = Antenna factor+ Insertion loss (cable loss + amplifier gain)

RE 1G-7GHz PK+AV Class B

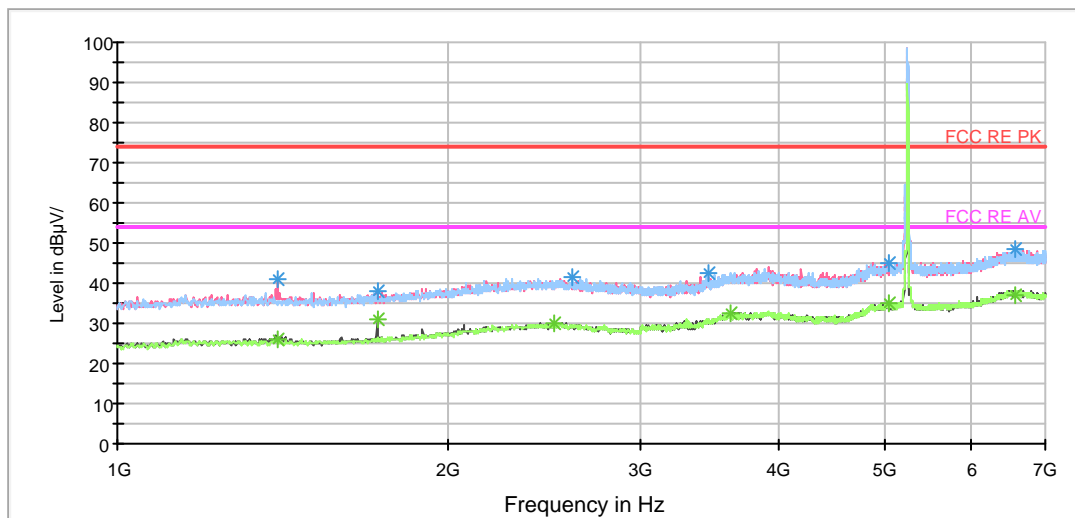

Radiates Emission from 1GHz to 7GHz
Note: The signal beyond the limit is carrier.

RE 3-18GHz PK+AV

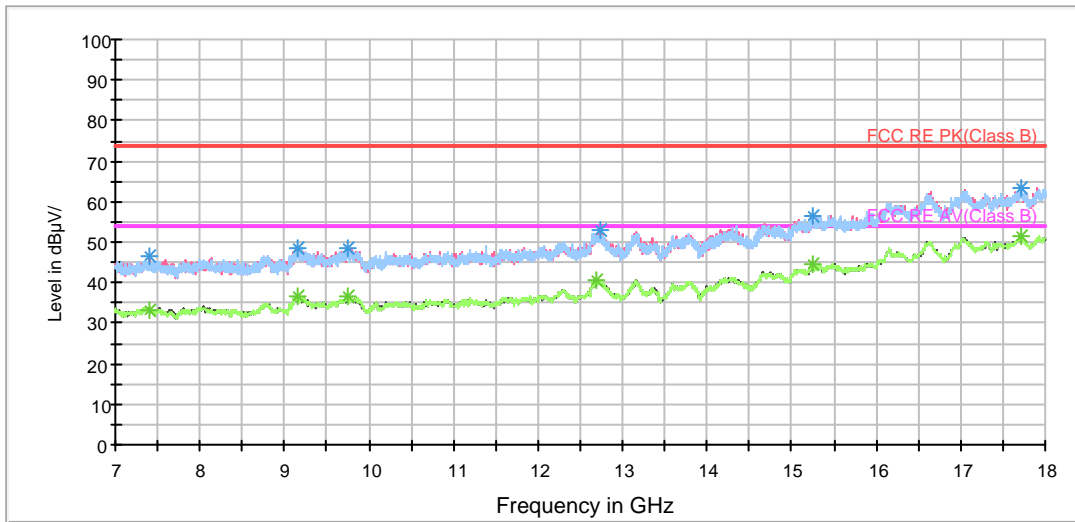

Radiates Emission from 7GHz to 18GHz

RE 18-26.5GHz PK+AV

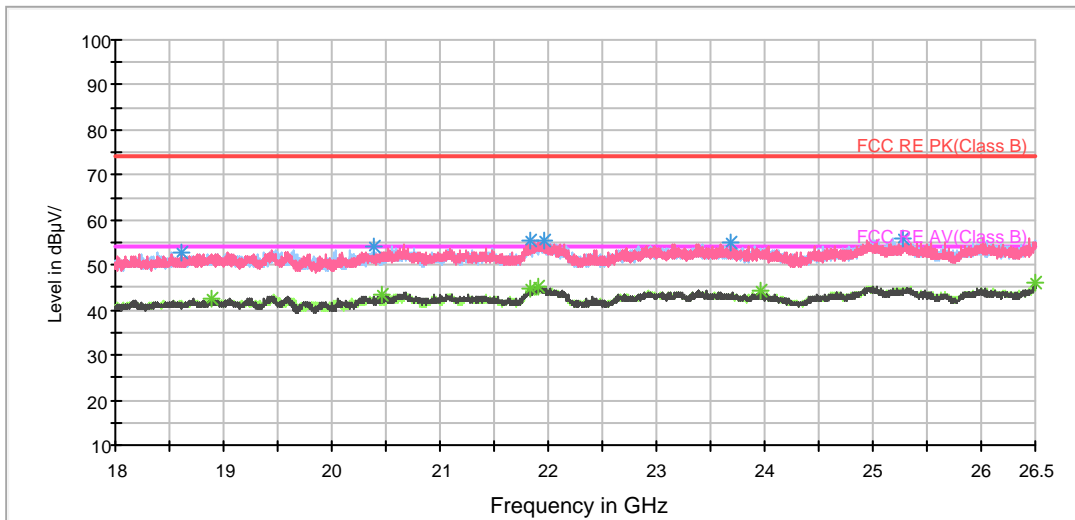

Radiates Emission from 18GHz to 26.5GHz



BELL RE 26.5-40GHz PK+AV



Radiates Emission from 26.5GHz to 40GHz



802.11n (HT20) CH52

Frequency (MHz)	Peak (dBuV/m)	Height (cm)	Polarization	Azimuth (deg)	Reading value (dBuV/m)	Correct Factor (dB)	Margin (dB)	Limit (dBuV/m)
1231.000000	37.8	100.0	V	359.0	45.3	-7.5	36.2	74
1724.500000	39.6	100.0	V	350.0	45.4	-5.8	34.4	74
2401.000000	41.2	100.0	H	9.0	44.4	-3.2	32.8	74
3647.500000	42.4	100.0	V	224.0	42.0	0.4	31.6	74
4927.000000	45.4	100.0	V	0.0	40.2	5.2	28.6	74
6518.500000	48.5	100.0	V	0.0	38.3	10.2	25.5	74

Remark: 1. Correction Factor = Antenna factor+ Insertion loss (cable loss + amplifier gain)

Frequency (MHz)	Average (dBuV/m)	Height (cm)	Polarization	Azimuth (deg)	Reading value (dBuV/m)	Correct Factor (dB)	Margin (dB)	Limit (dBuV/m)
1231.000000	25.4	100.0	V	359.0	32.9	-7.5	28.6	54
1724.500000	31.1	100.0	V	350.0	36.9	-5.8	22.9	54
2540.500000	29.9	100.0	H	4.0	32.7	-2.8	24.1	54
3617.500000	32.7	100.0	H	9.0	32.4	0.3	21.3	54
5038.000000	35.3	100.0	V	354.0	29.8	5.5	18.7	54
6518.500000	37.4	100.0	V	0.0	27.2	10.2	16.6	54

Remark: 1. Correction Factor = Antenna factor+ Insertion loss (cable loss + amplifier gain)

RE 1G-7GHz PK+AV Class B

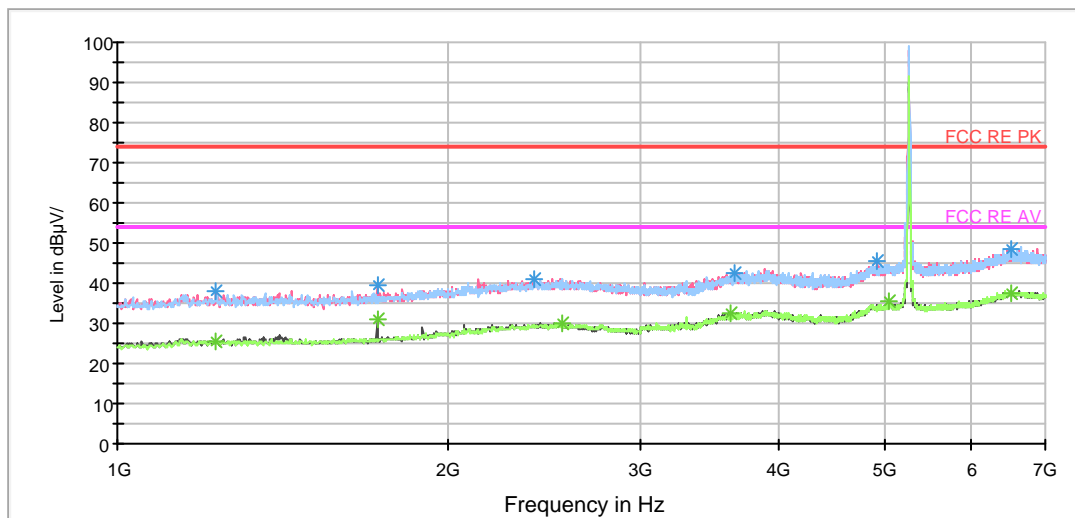

Radiates Emission from 1GHz to 7GHz
Note: The signal beyond the limit is carrier.

RE 3-18GHz PK+AV

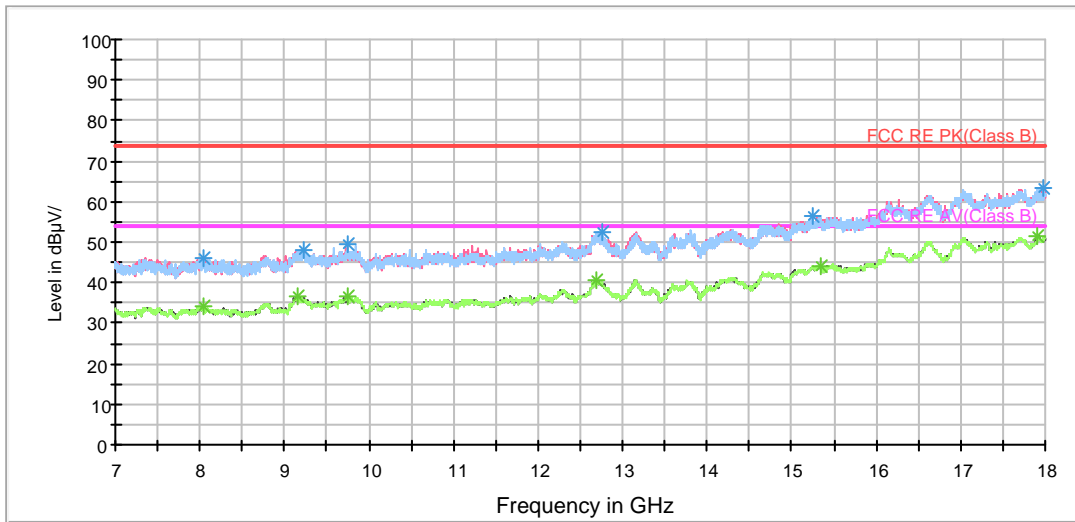

Radiates Emission from 7GHz to 18GHz

RE 18-26.5GHz PK+AV

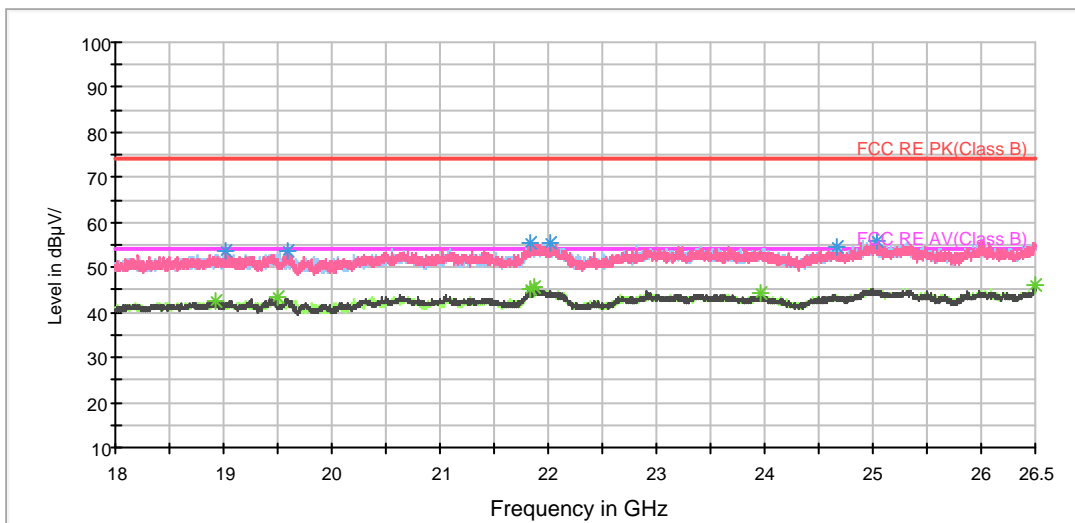

Radiates Emission from 18GHz to 26.5GHz

BELL RE 26.5-40GHz PK+AV

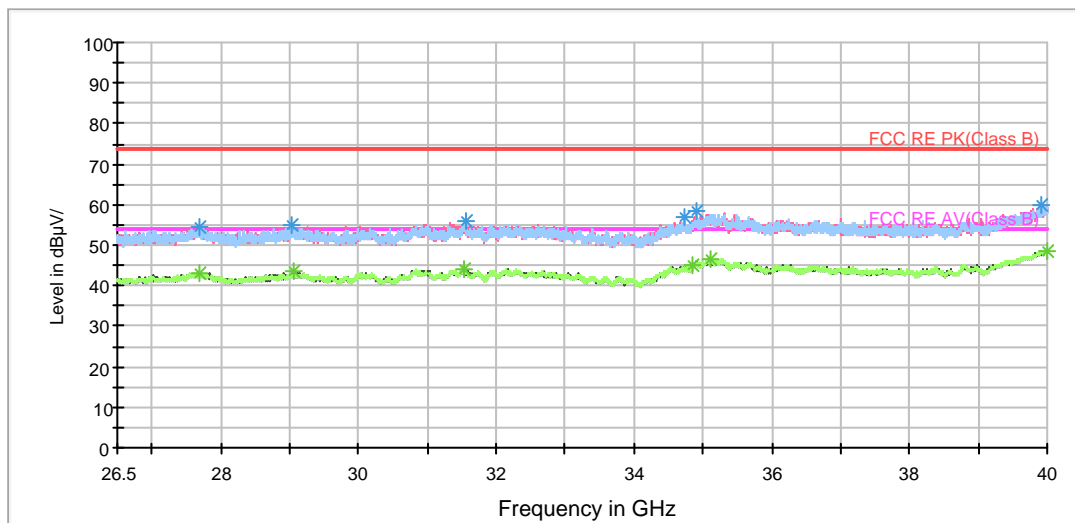

Radiates Emission from 26.5GHz to 40GHz



802.11n (HT20) CH56

Frequency (MHz)	Peak (dBuV/m)	Height (cm)	Polarization	Azimuth (deg)	Reading value (dBuV/m)	Correct Factor (dB)	Margin (dB)	Limit (dBuV/m)
1352.500000	37.9	100.0	V	0.0	45.0	-7.1	36.1	74
1724.500000	38.3	100.0	V	107.0	44.1	-5.8	35.7	74
2381.500000	41.4	100.0	H	116.0	44.7	-3.3	32.6	74
3616.000000	42.7	100.0	H	5.0	42.4	0.3	31.3	74
4846.000000	44.7	100.0	V	0.0	39.8	4.9	29.3	74
6457.000000	49.1	100.0	H	313.0	39.2	9.9	24.9	74

Remark: 1. Correction Factor = Antenna factor+ Insertion loss (cable loss + amplifier gain)

Frequency (MHz)	Average (dBuV/m)	Height (cm)	Polarization	Azimuth (deg)	Reading value (dBuV/m)	Correct Factor (dB)	Margin (dB)	Limit (dBuV/m)
1378.000000	26.3	100.0	V	6.0	33.3	-7.0	27.7	54
1724.500000	32.4	100.0	V	107.0	38.2	-5.8	21.6	54
2504.500000	30.0	100.0	H	246.0	32.8	-2.8	24.0	54
3640.000000	32.5	100.0	V	330.0	32.1	0.4	21.5	54
5057.500000	35.2	100.0	V	51.0	29.7	5.5	18.8	54
6457.000000	37.1	100.0	H	313.0	27.2	9.9	16.9	54

Remark: 1. Correction Factor = Antenna factor+ Insertion loss (cable loss + amplifier gain)

RE 1G-7GHz PK+AV Class B

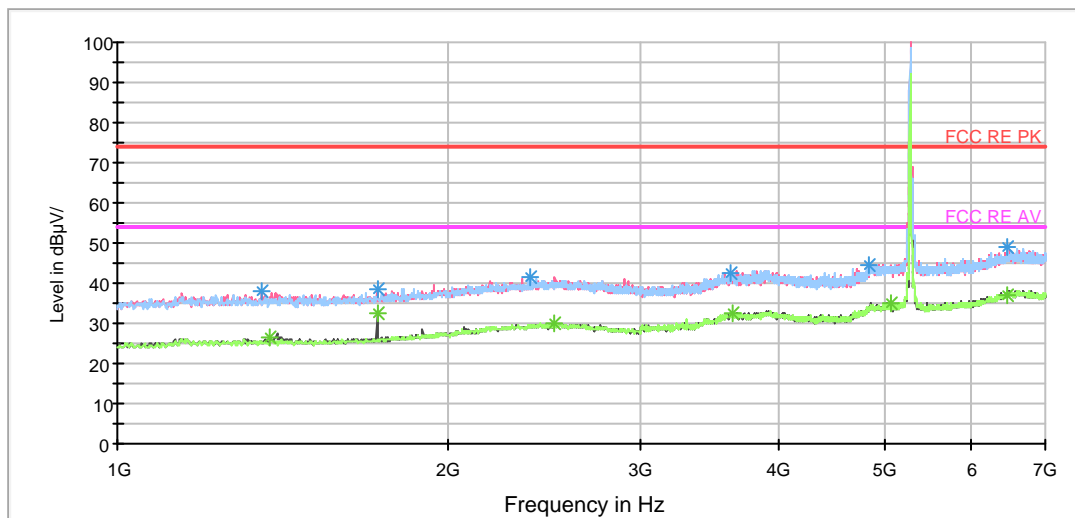

Radiates Emission from 1GHz to 3GHz
Note: The signal beyond the limit is carrier.



RE 3-18GHz PK+AV

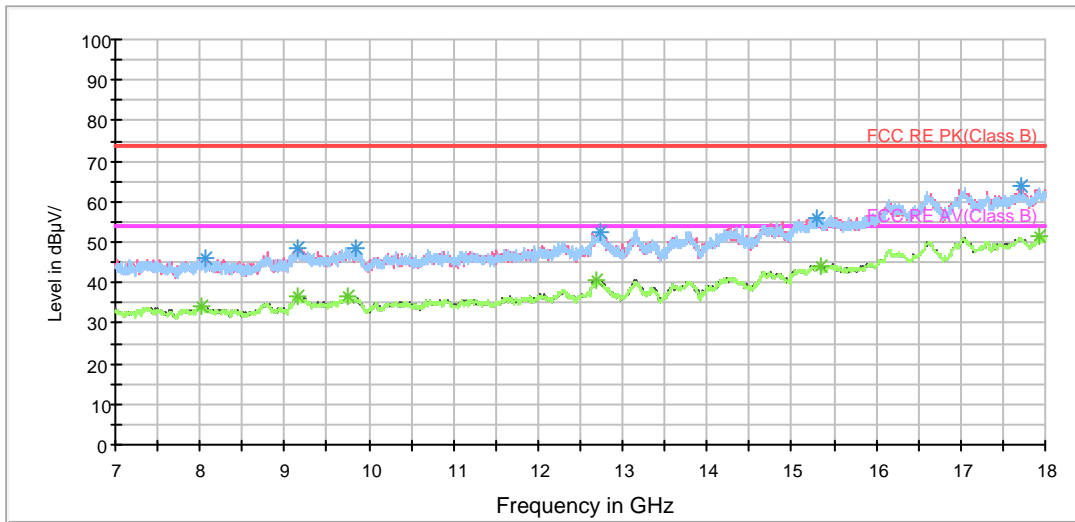

Radiates Emission from 7GHz to 18GHz

RE 18-26.5GHz PK+AV

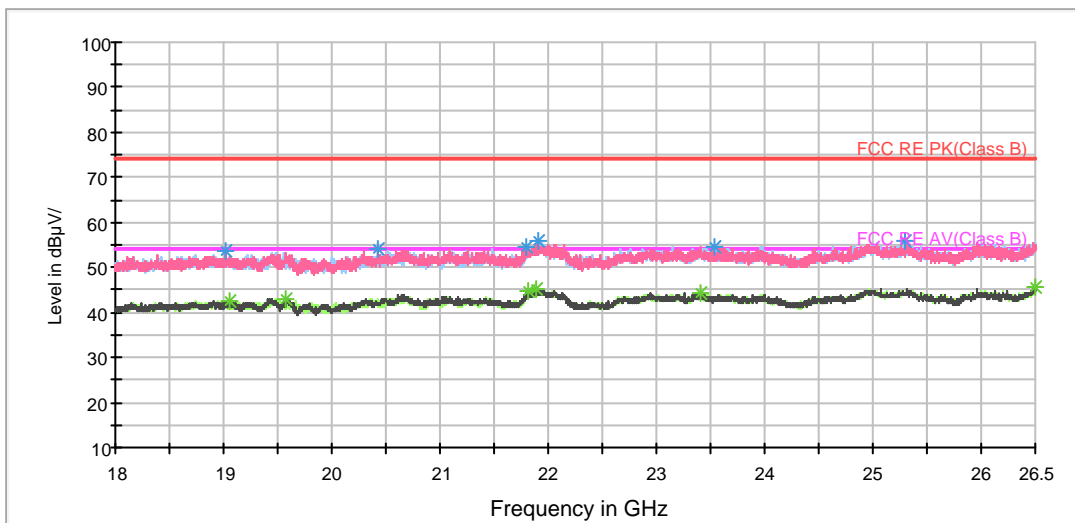

Radiates Emission from 18GHz to 26.5GHz

BELL RE 26.5-40GHz PK+AV

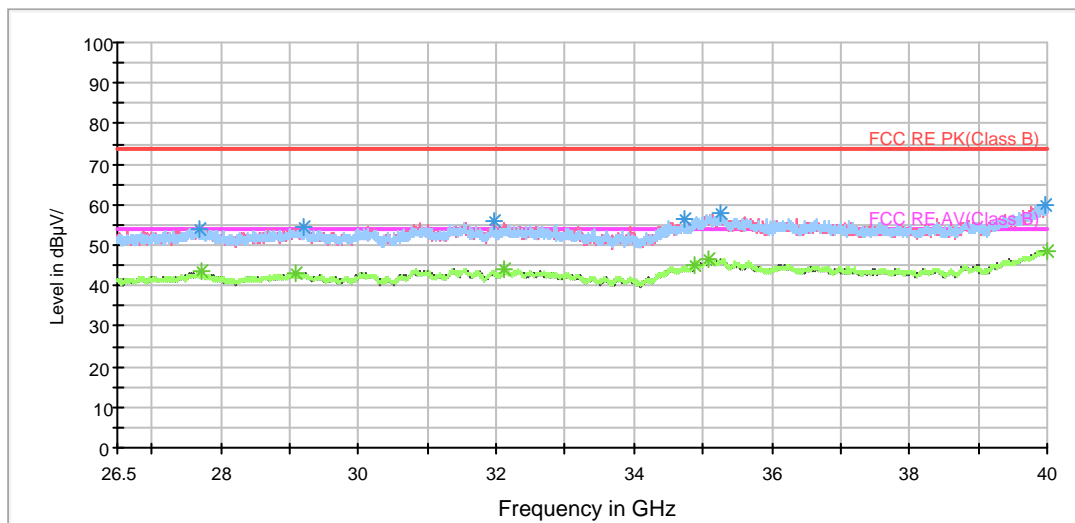

Radiates Emission from 26.5GHz to 40GHz



802.11n (HT20) CH64

Frequency (MHz)	Peak (dBuV/m)	Height (cm)	Polarization	Azimuth (deg)	Reading value (dBuV/m)	Correct Factor (dB)	Margin (dB)	Limit (dBuV/m)
1396.000000	40.5	100.0	V	356.0	47.5	-7.0	33.5	74
1724.500000	37.4	100.0	V	0.0	43.2	-5.8	36.6	74
2507.500000	41.7	100.0	V	278.0	44.5	-2.8	32.3	74
3616.000000	42.2	100.0	V	192.0	41.9	0.3	31.8	74
5023.000000	45.0	100.0	V	256.0	39.5	5.5	29.0	74
6475.000000	48.6	100.0	H	354.0	38.5	10.1	25.4	74

Remark: 1. Correction Factor = Antenna factor+ Insertion loss (cable loss + amplifier gain)

Frequency (MHz)	Average (dBuV/m)	Height (cm)	Polarization	Azimuth (deg)	Reading value (dBuV/m)	Correct Factor (dB)	Margin (dB)	Limit (dBuV/m)
1399.000000	27.9	100.0	V	0.0	34.8	-6.9	26.1	54
1724.500000	29.0	100.0	V	0.0	34.8	-5.8	25.0	54
2533.000000	29.8	100.0	H	0.0	32.6	-2.8	24.2	54
3620.500000	32.6	100.0	H	244.0	32.3	0.3	21.4	54
5038.000000	35.0	100.0	V	320.0	29.5	5.5	19.0	54
6475.000000	37.5	100.0	H	354.0	27.4	10.1	16.5	54

Remark: 1. Correction Factor = Antenna factor+ Insertion loss (cable loss + amplifier gain)

RE 1G-7GHz PK+AV Class B

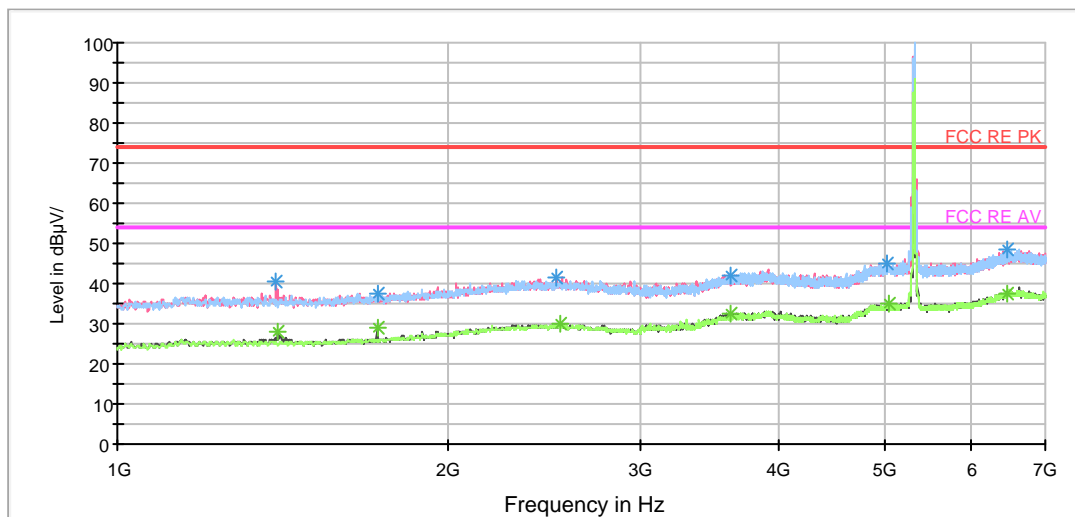

Radiates Emission from 1GHz to 7GHz
Note: The signal beyond the limit is carrier.

RE 3-18GHz PK+AV

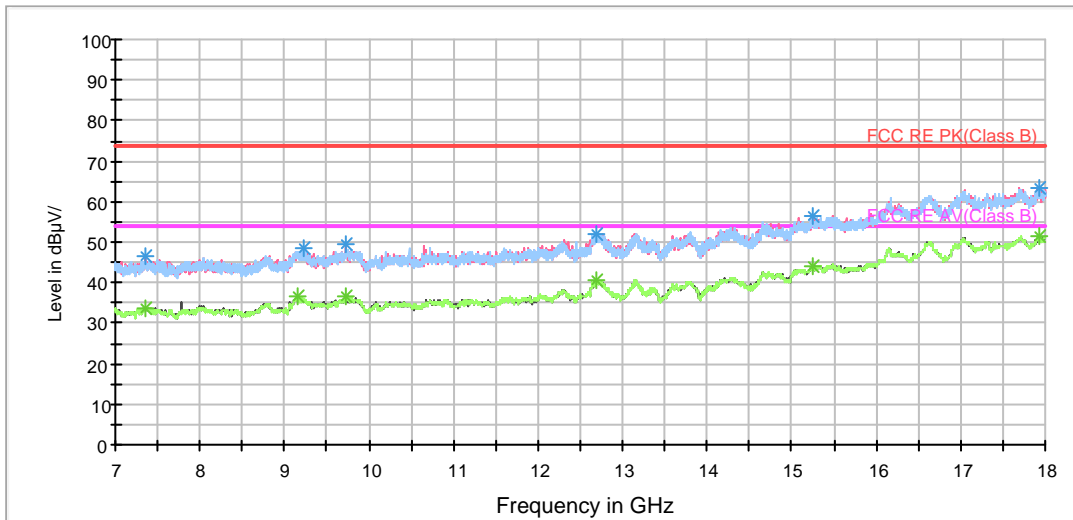

Radiates Emission from 7GHz to 18GHz

RE 18-26.5GHz PK+AV

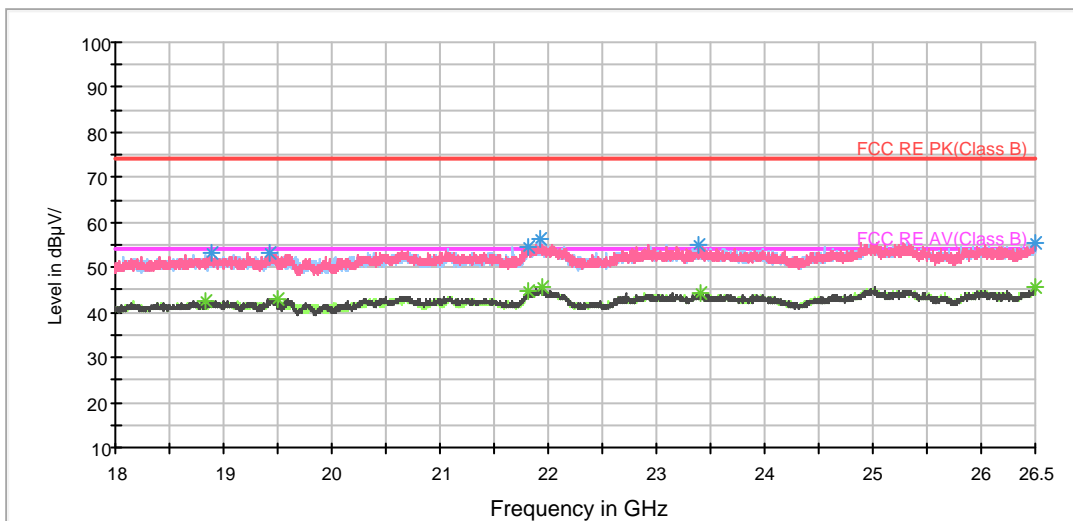

Radiates Emission from 18GHz to 26.5GHz



BELL RE 26.5-40GHz PK+AV

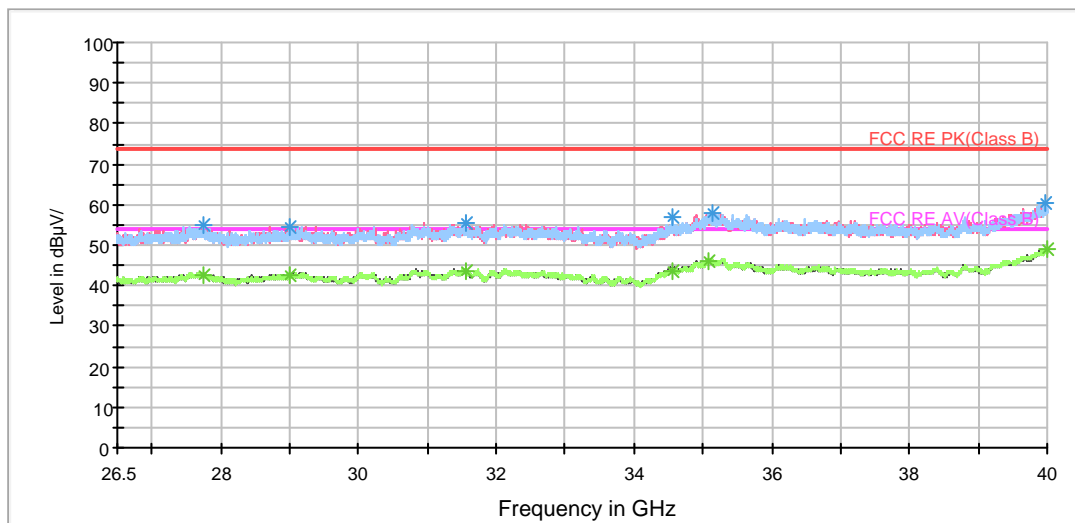

Radiates Emission from 26.5GHz to 40GHz



802.11n (HT20) CH100

Frequency (MHz)	Peak (dBuV/m)	Height (cm)	Polarization	Azimuth (deg)	Reading value (dBuV/m)	Correct Factor (dB)	Margin (dB)	Limit (dBuV/m)
1264.000000	38.4	100.0	V	139.0	45.8	-7.4	35.6	74
1724.500000	37.5	100.0	V	0.0	43.3	-5.8	36.5	74
2612.500000	41.2	100.0	H	297.0	43.9	-2.7	32.8	74
3656.500000	42.9	100.0	V	289.0	42.5	0.4	31.1	74
5044.000000	45.2	100.0	H	0.0	39.7	5.5	28.8	74
6605.500000	48.5	100.0	H	38.0	38.3	10.2	25.5	74

Remark: 1. Correction Factor = Antenna factor+ Insertion loss (cable loss + amplifier gain)

Frequency (MHz)	Average (dBuV/m)	Height (cm)	Polarization	Azimuth (deg)	Reading value (dBuV/m)	Correct Factor (dB)	Margin (dB)	Limit (dBuV/m)
1264.000000	25.1	100.0	V	139.0	32.5	-7.4	28.9	54
1724.500000	29.3	100.0	V	0.0	35.1	-5.8	24.7	54
2612.500000	29.0	100.0	H	297.0	31.7	-2.7	25.0	54
3584.500000	32.5	100.0	V	236.0	32.4	0.1	21.5	54
4867.000000	35.4	100.0	H	209.0	30.5	4.9	18.6	54
6605.500000	37.3	100.0	H	38.0	27.1	10.2	16.7	54

Remark: 1. Correction Factor = Antenna factor+ Insertion loss (cable loss + amplifier gain)

RE 1G-7GHz PK+AV Class B

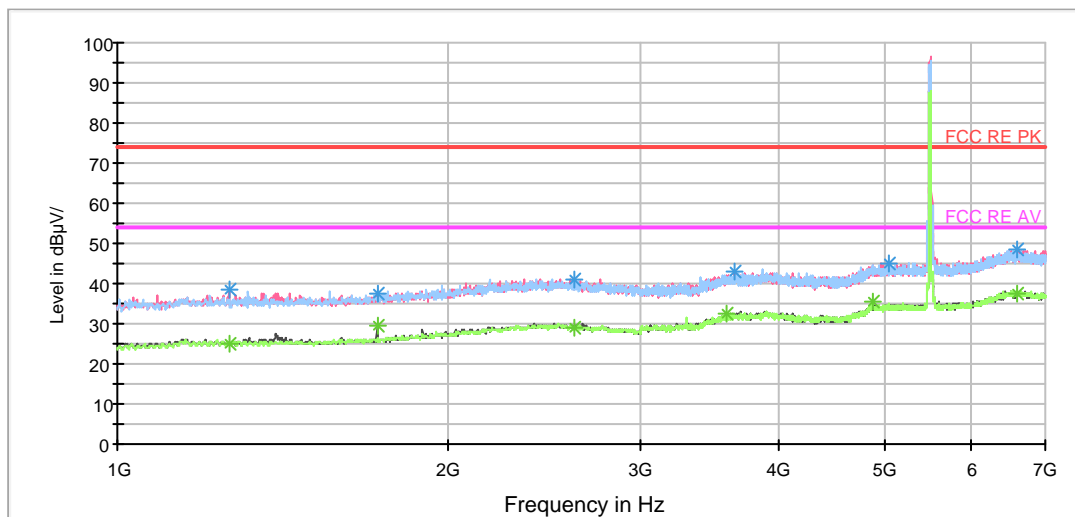

Radiates Emission from 1GHz to 7GHz
Note: The signal beyond the limit is carrier.

RE 3-18GHz PK+AV

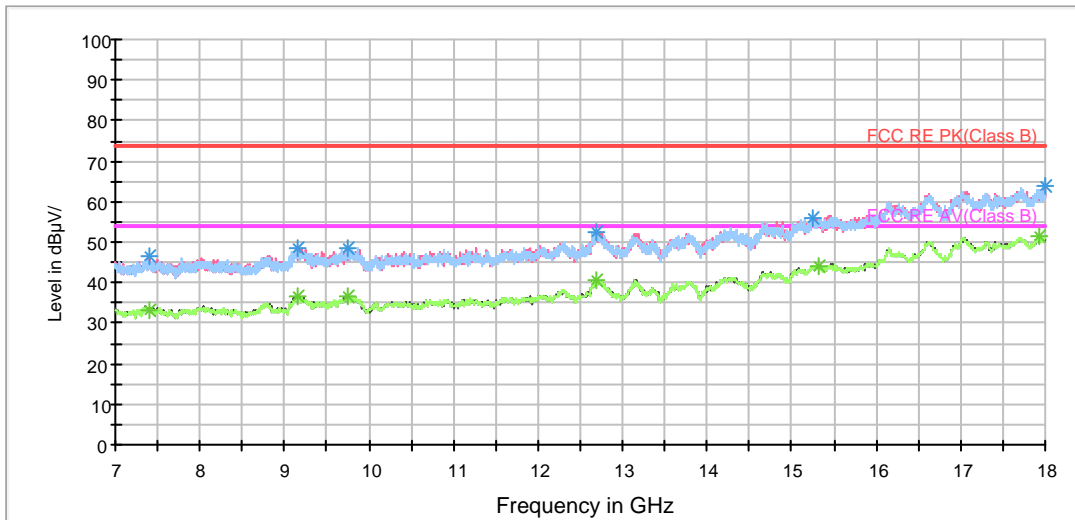

Radiates Emission from 7GHz to 18GHz

RE 18-26.5GHz PK+AV

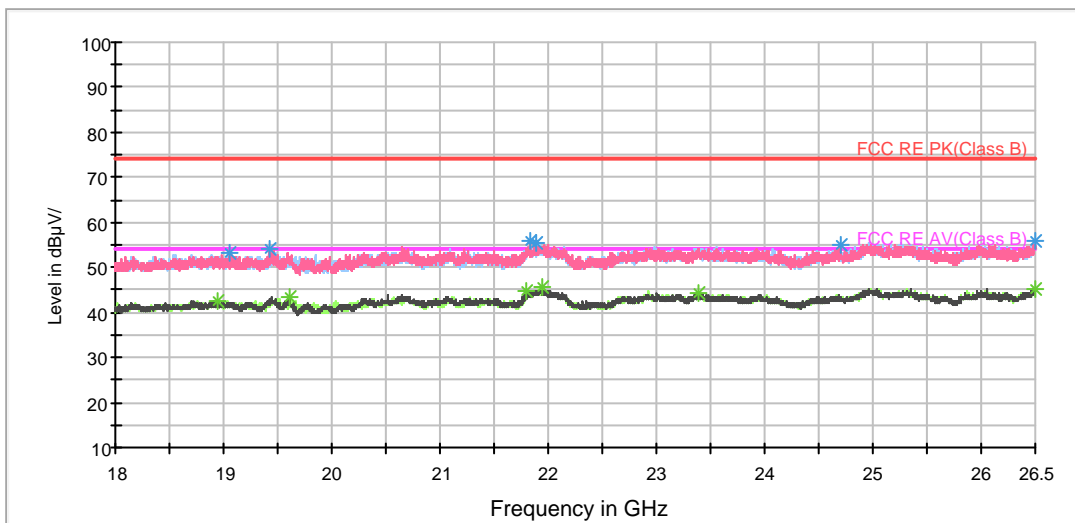

Radiates Emission from 18GHz to 26.5GHz



BELL RE 26.5-40GHz PK+AV

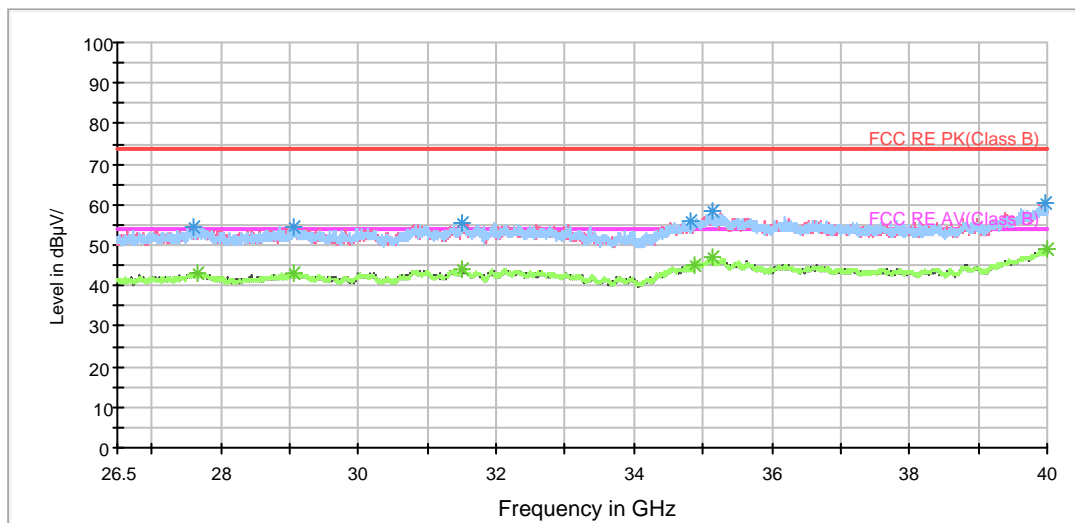

Radiates Emission from 26.5GHz to 40GHz



802.11n (HT20) CH116

Frequency (MHz)	Peak (dBuV/m)	Height (cm)	Polarization	Azimuth (deg)	Reading value (dBuV/m)	Correct Factor (dB)	Margin (dB)	Limit (dBuV/m)
1394.500000	41.5	100.0	V	0.0	48.5	-7.0	32.5	74
1726.000000	38.9	100.0	V	107.0	44.7	-5.8	35.1	74
2471.500000	41.4	100.0	H	0.0	44.4	-3.0	32.6	74
3587.500000	42.6	100.0	H	0.0	42.5	0.1	31.4	74
5005.000000	44.8	100.0	H	0.0	39.4	5.4	29.2	74
6680.500000	48.7	100.0	H	21.0	38.5	10.2	25.3	74

Remark: 1. Correction Factor = Antenna factor+ Insertion loss (cable loss + amplifier gain)

Frequency (MHz)	Average (dBuV/m)	Height (cm)	Polarization	Azimuth (deg)	Reading value (dBuV/m)	Correct Factor (dB)	Margin (dB)	Limit (dBuV/m)
1381.000000	26.4	100.0	V	194.0	33.4	-7.0	33.4	54
1724.500000	32.9	100.0	V	107.0	38.7	-5.8	38.7	54
2506.000000	29.8	100.0	V	17.0	32.6	-2.8	32.6	54
3644.500000	32.5	100.0	V	0.0	32.1	0.4	32.1	54
5036.500000	35.0	100.0	H	3.0	29.5	5.5	29.5	54
6680.500000	37.1	100.0	H	21.0	26.9	10.2	26.9	54

Remark: 1. Correction Factor = Antenna factor+ Insertion loss (cable loss + amplifier gain)

RE 1G-7GHz PK+AV Class B

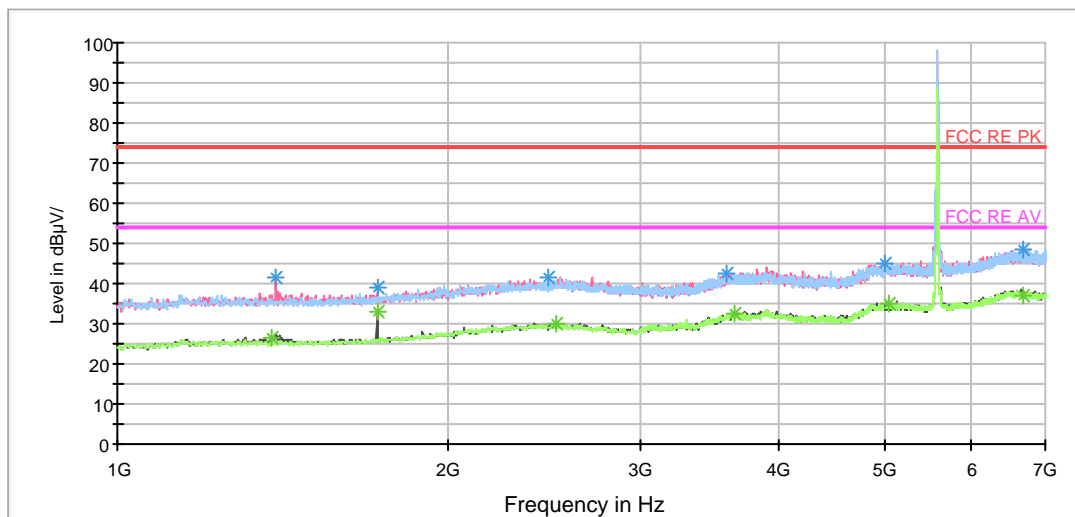

Radiates Emission from 1GHz to 7GHz
 Note: The signal beyond the limit is carrier.

RE 3-18GHz PK+AV

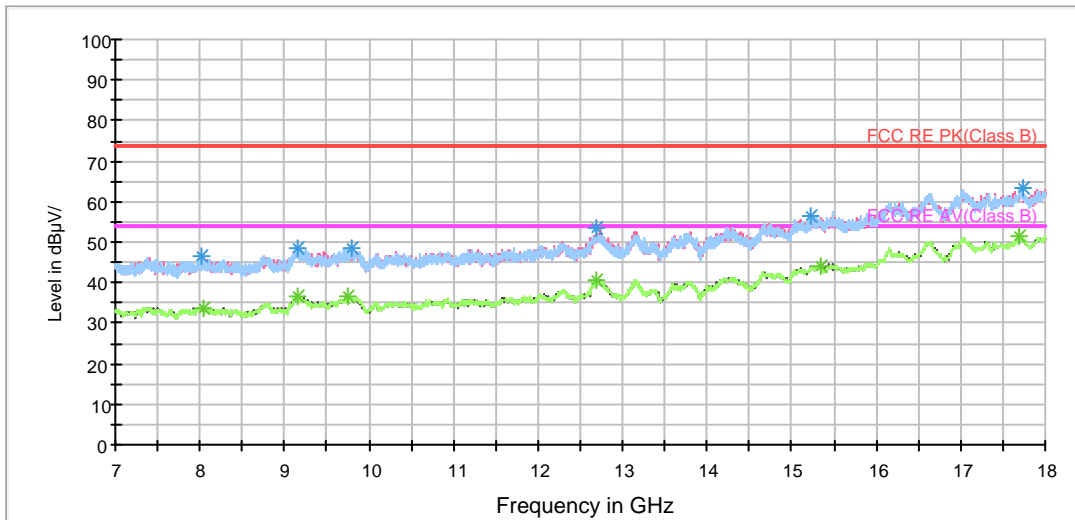

Radiates Emission from 7GHz to 18GHz

RE 18-26.5GHz PK+AV

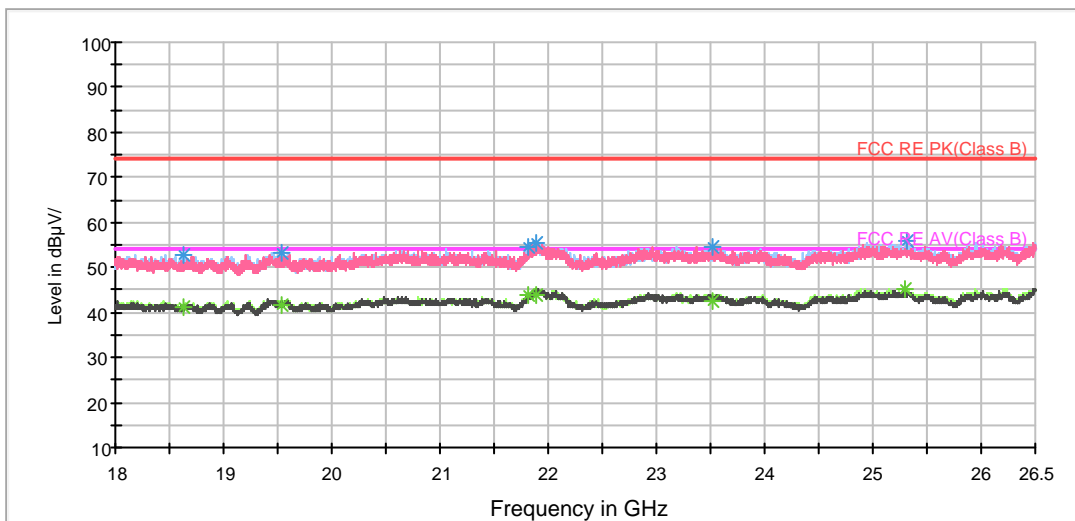

Radiates Emission from 18GHz to 26.5GHz



BELL RE 26.5-40GHz PK+AV

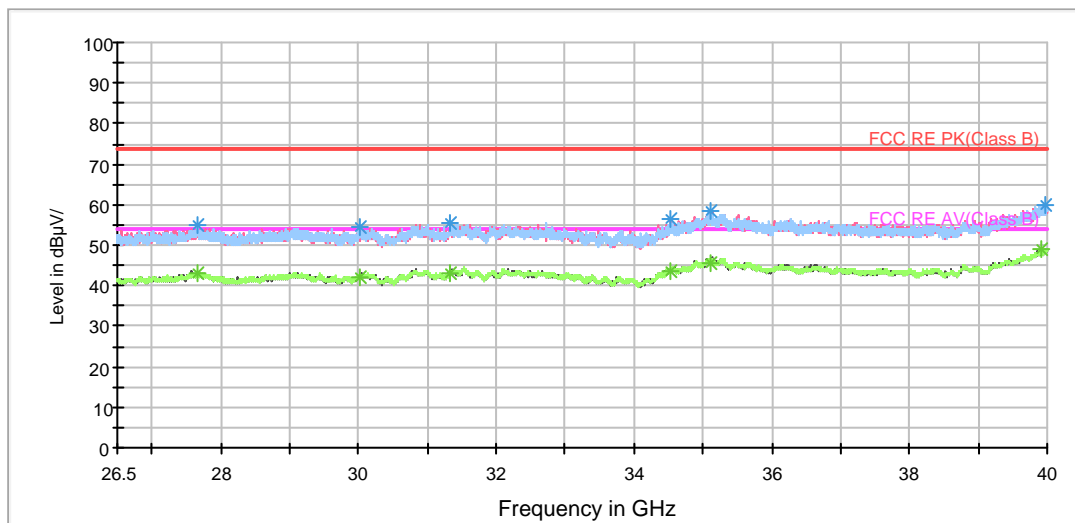

Radiates Emission from 26.5GHz to 40GHz



802.11n (HT20) CH140

Frequency (MHz)	Peak (dBuV/m)	Height (cm)	Polarization	Azimuth (deg)	Reading value (dBuV/m)	Correct Factor (dB)	Margin (dB)	Limit (dBuV/m)
1397.500000	41.6	100.0	V	6.0	48.5	-6.9	32.4	74
1724.500000	40.0	100.0	V	105.0	45.8	-5.8	34.0	74
2557.000000	41.2	100.0	H	0.0	44.0	-2.8	32.8	74
3635.500000	42.8	100.0	V	0.0	42.5	0.3	31.2	74
5047.000000	45.3	100.0	V	320.0	39.8	5.5	28.7	74
6734.500000	49.4	100.0	H	9.0	39.3	10.1	24.6	74

Remark: 1. Correction Factor = Antenna factor+ Insertion loss (cable loss + amplifier gain)

Frequency (MHz)	Average (dBuV/m)	Height (cm)	Polarization	Azimuth (deg)	Reading value (dBuV/m)	Correct Factor (dB)	Margin (dB)	Limit (dBuV/m)
1379.500000	26.7	100.0	V	202.0	33.7	-7.0	27.3	54
1724.500000	32.6	100.0	V	105.0	38.4	-5.8	21.4	54
2501.500000	29.9	100.0	V	0.0	32.7	-2.8	24.1	54
3637.000000	32.4	100.0	H	80.0	32.0	0.4	21.6	54
5047.000000	34.8	100.0	V	320.0	29.3	5.5	19.2	54
6734.500000	37.1	100.0	H	9.0	27.0	10.1	16.9	54

Remark: 1. Correction Factor = Antenna factor+ Insertion loss (cable loss + amplifier gain)

RE 1G-7GHz PK+AV Class B

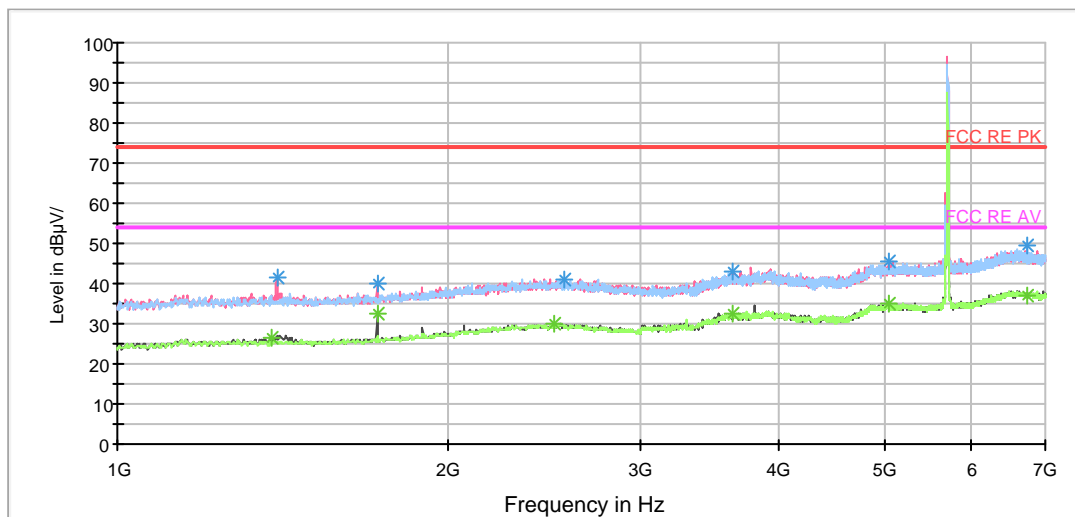

Radiates Emission from 1GHz to 7GHz
Note: The signal beyond the limit is carrier.



RE 3-18GHz PK+AV

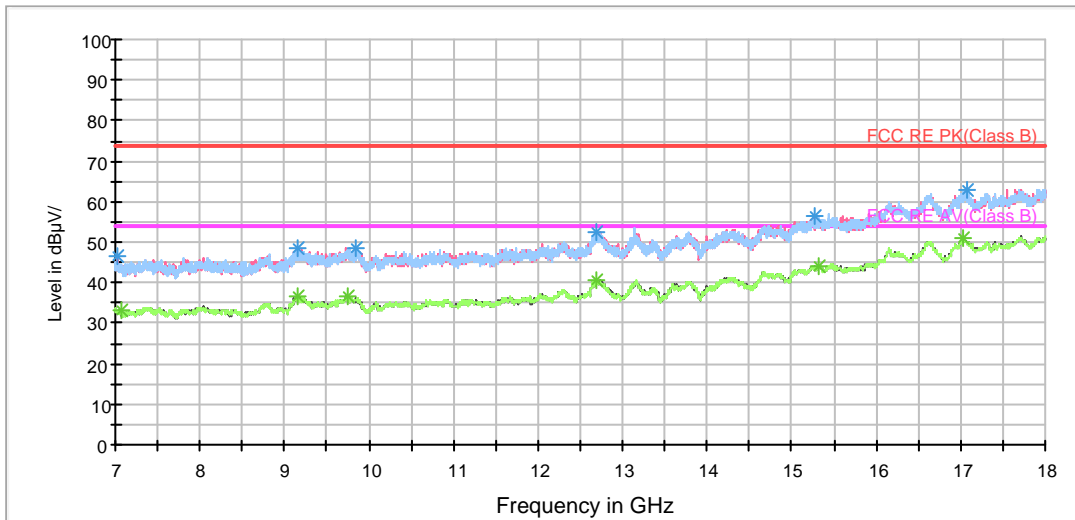

Radiates Emission from 7GHz to 18GHz

RE 18-26.5GHz PK+AV

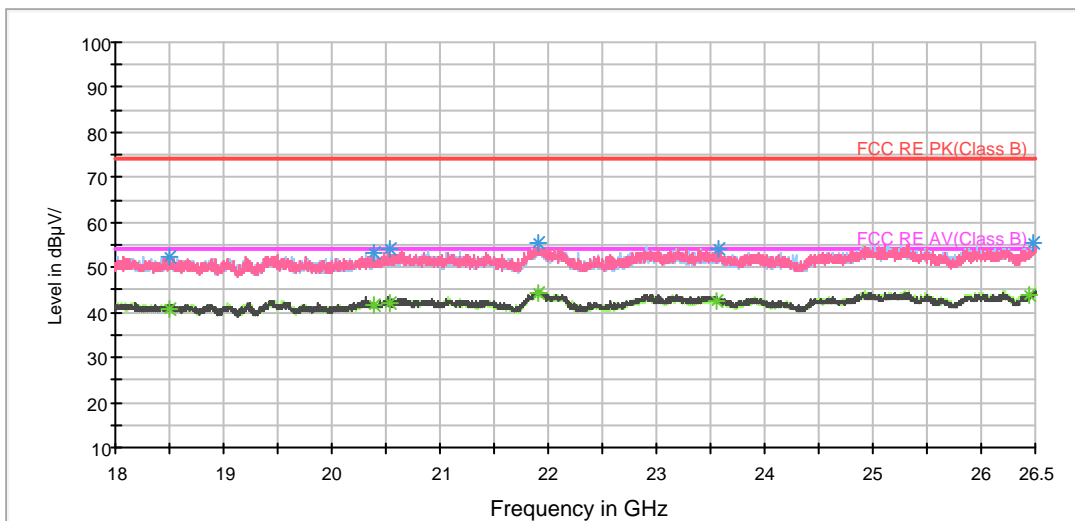

Radiates Emission from 18GHz to 26.5GHz

BELL RE 26.5-40GHz PK+AV

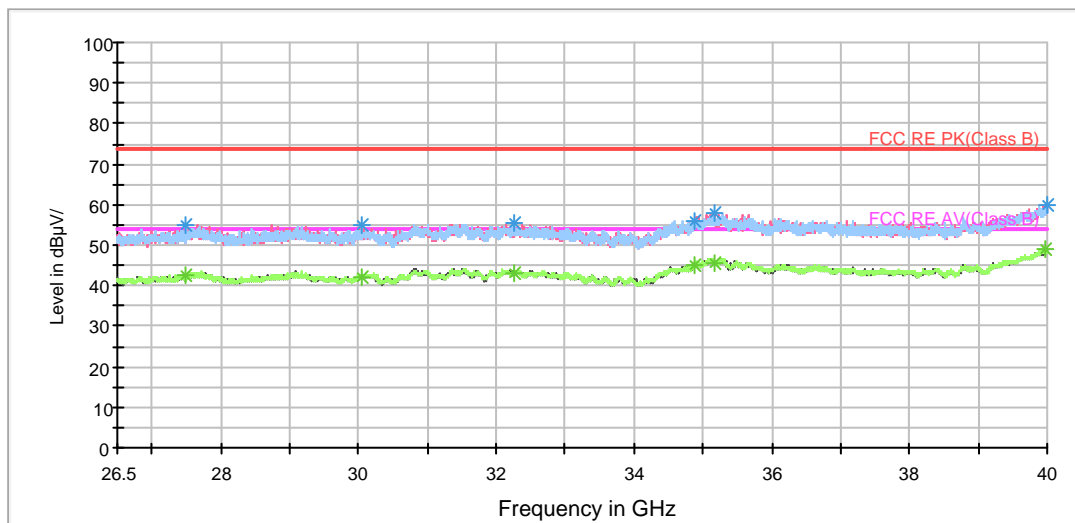

Radiates Emission from 26.5GHz to 40GHz



802.11n (HT20) CH149

Frequency (MHz)	Peak (dBuV/m)	Height (cm)	Polarization	Azimuth (deg)	Reading value (dBuV/m)	Correct Factor (dB)	Margin (dB)	Limit (dBuV/m)
1142.500000	37.5	100.0	H	4.0	45.2	-7.7	36.5	74
1724.500000	38.6	100.0	V	105.0	44.4	-5.8	35.4	74
2069.500000	41.8	100.0	V	94.0	46.3	-4.5	32.2	74
3575.500000	43.2	100.0	H	231.0	43.1	0.1	30.8	74
5053.000000	45.5	100.0	H	0.0	40.0	5.5	28.5	74
6623.500000	48.2	100.0	H	0.0	38.0	10.2	25.8	74

Remark: 1. Correction Factor = Antenna factor+ Insertion loss (cable loss + amplifier gain)

Frequency (MHz)	Average (dBuV/m)	Height (cm)	Polarization	Azimuth (deg)	Reading value (dBuV/m)	Correct Factor (dB)	Margin (dB)	Limit (dBuV/m)
1142.500000	25.7	100.0	H	4.0	33.4	-7.7	28.3	54
1724.500000	32.2	100.0	V	105.0	38.0	-5.8	21.8	54
2069.500000	31.5	100.0	V	94.0	36.0	-4.5	22.5	54
3650.500000	32.9	100.0	V	267.0	32.5	0.4	21.1	54
5051.500000	35.0	100.0	V	192.0	29.5	5.5	19.0	54
6623.500000	37.2	100.0	H	0.0	27.0	10.2	16.8	54

Remark: 1. Correction Factor = Antenna factor+ Insertion loss (cable loss + amplifier gain)

RE 1G-7GHz PK+AV Class B

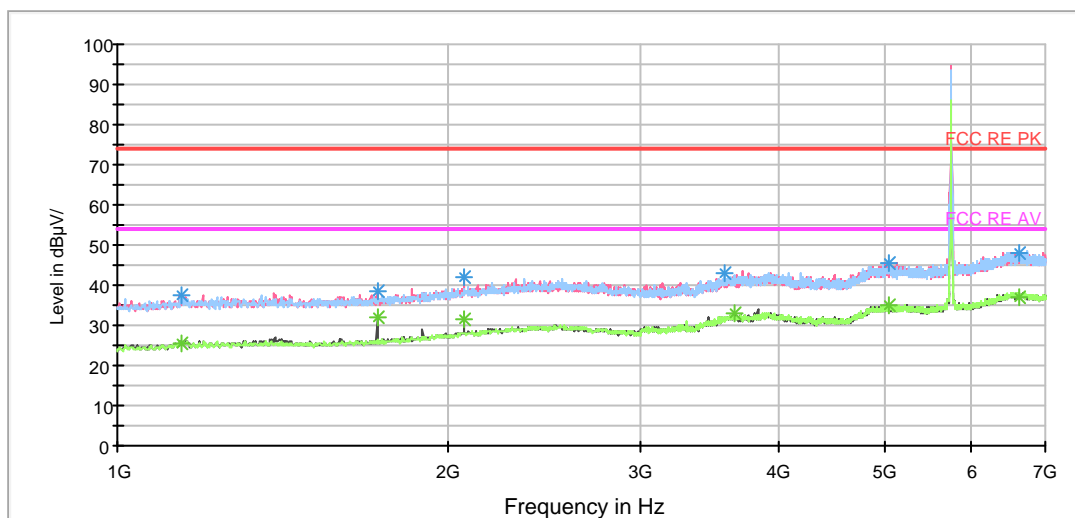

Radiates Emission from 1GHz to 7GHz
Note: The signal beyond the limit is carrier.